

1290 SUPER ADVENTURE R

Art. no. 3214297en



Congratulations on your decision to purchase a KTM motorcycle. You are now the owner of a state-of-the-art sports vehicle which, with appropriate care, will bring you pleasure for a long time to come.

We wish you good and safe riding at all times!

Enter the serial numbers of your vehicle below.

Vehicle identification number (📖 p. 13)	Dealer's stamp
Engine number (📖 p. 13)	

The Owner's Manual contained the latest information for this model series at the time of publication. However, minor differences due to further developments in design cannot be ruled out completely.

All specifications contained herein are non-binding. KTM Sportmotorcycle GmbH specifically reserves the right to modify or delete technical specifications, prices, colors, forms, materials, services, designs, equipment, etc., without prior notice and without specifying reasons, to adapt these to local conditions, as well as to stop production of a particular model without prior notice. KTM accepts no liability for delivery options, deviations from figures and descriptions, misprints, and other errors. The models portrayed partly contain special equipment that does not belong to the regular scope of supply.

© 2021 KTM Sportmotorcycle GmbH, Mattighofen Austria

All rights reserved

Reproduction, even in part, as well as copying of all kinds, is permitted only with the express written permission of the copyright owner.



ISO 9001(12 100 6061)

KTM applies quality assurance processes that lead to the highest possible product quality as defined in the ISO 9001 international quality management standard.

Issued by: TÜV Management Service

REG.NO. 12 100 6061

KTM Sportmotorcycle GmbH
Stallhofnerstraße 3
5230 Mattighofen, Austria

This document is valid for the following models:

1290 SUPER ADVENTURE R EU (F9903U6, F9903U7)

1290 SUPER ADVENTURE R JP (F9986U7)

1290 SUPER ADVENTURE R CN (F9987U7)



TABLE OF CONTENTS

1	MEANS OF REPRESENTATION	6	6.16	Steering lock (antenna).....	21
1.1	Symbols used	6	6.17	Immobilizer	21
1.2	Formats used.....	6	6.18	RACE ON key	21
2	SAFETY ADVICE.....	7	6.19	Anti-relay attack (ARA)	22
2.1	Use definition – intended use.....	7	6.20	Socket for electrical accessories	23
2.2	Misuse.....	7	6.21	USB socket	23
2.3	Safety advice.....	7	6.22	Opening fuel tank filler cap.....	23
2.4	Degrees of risk and symbols.....	7	6.23	Closing the fuel tank filler cap.....	24
2.5	Tampering warning.....	8	6.24	Fuel petcocks	24
2.6	Safe operation	8	6.25	Opening storage compartment.....	25
2.7	Protective clothing	9	6.26	Closing storage compartment	25
2.8	Work rules.....	9	6.27	Seat release	26
2.9	Environment.....	9	6.28	Emergency seat release	26
2.10	Owner's Manual	9	6.29	Grab handles.....	26
3	IMPORTANT NOTES.....	10	6.30	Luggage rack plate.....	26
3.1	Manufacturer warranty, implied warranty.....	10	6.31	Passenger foot pegs	27
3.2	Fuel, auxiliary substances	10	6.32	Shift lever	27
3.3	Spare parts, accessories	10	6.33	Foot brake lever	27
3.4	Service	10	6.34	Side stand.....	28
3.5	Figures	10	6.35	Center stand.....	28
3.6	Customer service.....	10	7	COMBINATION INSTRUMENT	29
4	VIEW OF VEHICLE	11	7.1	Combination instrument	29
4.1	View of vehicle, front left (example) ...	11	7.2	Activation and test	29
4.2	View of vehicle, rear right (example).....	12	7.3	Day-night mode	30
5	SERIAL NUMBERS	13	7.4	Warnings.....	31
5.1	Vehicle identification number.....	13	7.5	Ice warning	31
5.2	Type label	13	7.6	Indicator lamps.....	32
5.3	Engine number	13	7.7	Display	33
5.4	Fork part number	13	7.8	Display Rally (optional).....	34
5.5	Shock absorber article number	14	7.9	Engine speed.....	35
5.6	Steering damper article number	14	7.10	Shift light.....	35
6	CONTROLS.....	15	7.11	Cruise control indicator.....	36
6.1	Clutch lever.....	15	7.12	Speed	36
6.2	Handbrake lever.....	15	7.13	ABS display.....	36
6.3	Throttle grip	15	7.14	MTC display	36
6.4	Combination switch, left side	15	7.15	Ride-Mode display	37
6.5	Light switch	16	7.16	Coolant temperature indicator	37
6.6	Cruise control buttons	16	7.17	Heated grip (optional).....	37
6.7	+RES/-SET button.....	18	7.18	Seat heating (optional)	37
6.8	Menu switches.....	18	7.19	Fuel level display	38
6.9	Turn signal switch.....	18	7.20	Favourites display	38
6.10	Horn button.....	19	7.21	Navigation display (optional)	38
6.11	Combination switch, right	19	7.22	Call display	39
6.12	Hazard warning flasher switch.....	19	7.23	Menu	39
6.13	C1 and C2 switch	20	7.23.1	KTM MY RIDE	39
6.14	RACE ON button.....	20	7.23.2	Phone.....	40
6.15	Start button/emergency OFF switch ...	20	7.23.3	Rider's Headset	41
			7.23.4	Headset Type	41
			7.23.5	Navigation (optional)	42
			7.23.6	Navigation volume (optional).....	42
			7.23.7	Audio	43
			7.23.8	Audio	43
			7.23.9	Bike Info.....	44























7.23.10	Bike Info.....	44	8.5	Adjusting the basic position of the hand brake lever	63
7.23.11	Trip	45	8.6	Rider footrests	64
7.23.12	Trip 1	45	8.7	Adjusting the footrests 	64
7.23.13	Trip 2	45	8.8	Checking the basic position of the shift lever	65
7.23.14	Motorcycle	46	8.9	Adjusting the basic position of the shift lever 	66
7.23.15	Ride Mode	46	8.10	Setting the shift lever stub	67
7.23.16	MTC	47	8.11	Adjusting the basic position of the foot brake lever 	67
7.23.17	MTC+MSR (optional).....	47	8.12	Adjusting the tilt of the combination instrument	68
7.23.18	ABS.....	48	9	PREPARING FOR USE.....	69
7.23.19	Throttle Response (optional)	49	9.1	Advice on preparing for first use	69
7.23.20	Slip Adjuster (optional).....	49	9.2	Running in the engine	70
7.23.21	Settings	50	9.3	Loading the vehicle	70
7.23.22	Custom Switch	50	10	RIDING INSTRUCTIONS	72
7.23.23	Taste C1 und C2.....	51	10.1	Checks and maintenance measures when preparing for use	72
7.23.24	Favourites	51	10.2	Starting.....	72
7.23.25	Favourites indicator 1-4	51	10.3	Starting off.....	74
7.23.26	TPMS Setting.....	52	10.4	Quickshifter + (optional)	74
7.23.27	Anti Relay Attack	53	10.5	Starting with HHC (optional)	74
7.23.28	Display Theme.....	53	10.6	Shifting, riding	75
7.23.29	Button Illumination.....	53	10.7	MSR (optional)	77
7.23.30	DRL	53	10.8	Braking.....	78
7.23.31	Bluetooth	54	10.9	Stopping, parking.....	79
7.23.32	Quickshifter + (optional).....	54	10.10	Transporting.....	80
7.23.33	Hill Hold Control (optional)	54	10.11	Refueling	80
7.23.34	Shift Light	54	11	SERVICE SCHEDULE	82
7.23.35	Shift Light State	55	11.1	Additional information	82
7.23.36	Shift Light RPM1.....	55	11.2	Required work	82
7.23.37	Shift Light RPM2.....	55	11.3	Recommended work	83
7.23.38	Clock & Date	56	12	SUSPENSION SETTING.....	84
7.23.39	Clock Format	56	12.1	Fork/shock absorber	84
7.23.40	Date Format	56	12.2	Adjusting the compression damping of the fork	84
7.23.41	Units	56	12.3	Adjusting the rebound damping of the fork	85
7.23.42	Units Distance.....	57	12.4	Adjusting the spring preload of the fork	85
7.23.43	Units Temperature	57	12.5	Compression damping of the shock absorber.....	86
7.23.44	Units Consumption	57	12.6	Adjusting the low-speed compression damping of the shock absorber.....	86
7.23.45	Units Pressure.....	57	12.7	Adjusting the high-speed compression damping of the shock absorber.....	87
7.23.46	Settings Heating.....	58	12.8	Adjusting the rebound damping of the shock absorber	88
7.23.47	Settings Heating Grips	58			
7.23.48	Settings Heating Rider Seat	58			
7.23.49	Settings Heating Pillion Seat	58			
7.23.50	Extra Functions	59			
7.23.51	Setting the time and date	59			
7.23.52	Heating (function optional)	60			
7.23.53	Heating Grips (function optional)	61			
7.23.54	Heating Rider Seat (function optional)	61			
8	ERGONOMICS	62			
8.1	Handlebar position	62			
8.2	Adjusting the handlebar position 	62			
8.3	Adjusting the windshield	63			
8.4	Adjusting the basic position of the clutch lever	63			

TABLE OF CONTENTS

12.9	Adjusting the spring preload of the shock absorber	88	14.3	Checking the front brake fluid level	115
13	SERVICE WORK ON THE CHASSIS.....	89	14.4	Adding front brake fluid 	116
13.1	Raising the vehicle with the center stand	89	14.5	Checking the front brake linings	117
13.2	Removing the vehicle from the center stand	89	14.6	Checking the rear brake fluid level	117
13.3	Removing the seat	89	14.7	Adding rear brake fluid 	118
13.4	Mounting the seat	90	14.8	Checking the rear brake linings	119
13.5	Checking for chain dirt	90	15	WHEELS, TIRES	121
13.6	Cleaning the chain	90	15.1	Removing the front wheel 	121
13.7	Checking the chain tension	91	15.2	Installing the front wheel 	122
13.8	Adjusting the chain tension.....	92	15.3	Removing the rear wheel 	123
13.9	Checking the chain, rear sprocket, and engine sprocket	93	15.4	Installing the rear wheel 	124
13.10	Checking/correcting the fluid level of the hydraulic clutch	94	15.5	Checking the rear hub damping rubber pieces 	126
13.11	Checking steering head bearing play	95	15.6	Checking the tire condition	127
13.12	Removing the bottom triple clamp cover	96	15.7	Checking tire pressure	128
13.13	Installing the bottom triple clamp cover	96	15.8	Checking spoke tension	128
13.14	Removing the windshield	96	15.9	Using tire repair spray	129
13.15	Installing the windshield.....	97	16	ELECTRICAL SYSTEM	130
13.16	Removing storage compartment.....	97	16.1	Low beam	130
13.17	Installing storage compartment	98	16.2	High beam	130
13.18	Removing the top fuel tank fairing	98	16.3	Daytime running light (DRL).....	130
13.19	Installing the top fuel tank fairing.....	99	16.4	Cornering light	131
13.20	Removing the bottom fuel tank fairing.....	99	16.5	Removing the 12 V battery 	131
13.21	Installing the bottom fuel tank fairing.....	100	16.6	Installing the 12-V battery 	132
13.22	Removing the front side spoiler	101	16.7	Charging the 12-V battery 	133
13.23	Installing the front side spoiler	102	16.8	Changing the RACE-ON key battery	135
13.24	Removing the front side cover 	102	16.9	Changing the main fuse	136
13.25	Installing the front side cover 	103	16.10	Changing the fuses in the fuse box	137
13.26	Removing the mask spoiler 	104	16.11	Checking the headlight setting	138
13.27	Installing the mask spoiler 	106	16.12	Adjusting the headlight range.....	139
13.28	Removing the engine guard	108	16.13	Diagnostics connector	139
13.29	Installing the engine guard	108	16.14	Accessories circuit 1 and accessories circuit 2 front.....	139
13.30	Removing the oil plug cover	109	16.15	Accessories circuit 1 and accessories circuit 2, rear	140
13.31	Installing oil plug cover	109	17	COOLING SYSTEM	141
13.32	Removing front fender	109	17.1	Checking the coolant level in the compensating tank.....	141
13.33	Installing front fender.....	109	17.2	Correcting the coolant level in the compensating tank.....	141
13.34	Cleaning the dust boots of the fork legs 	110	18	TUNING THE ENGINE	143
13.35	Removing the crash bar 	110	18.1	Ride Mode	143
13.36	Installing the crash bar 	111	18.2	Motorcycle traction control (MTC)....	143
14	BRAKE SYSTEM	113	18.3	Slip Adjuster (optional).....	144
14.1	Anti-lock braking system (ABS)	113	18.4	Throttle Response (optional)	144
14.2	Checking the brake discs	114			

19	SERVICE WORK ON THE ENGINE	145	31.2	Yellow and orange symbols.....	176
19.1	Checking the engine oil level.....	145	31.3	Green and blue symbols.....	176
19.2	Changing the engine oil and oil filter, cleaning the oil screens 	145	INDEX.....		177
19.3	Adding engine oil	148			
20	CLEANING, CARE	150			
20.1	Cleaning the motorcycle	150			
20.2	Checks and maintenance steps for winter operation.....	151			
21	STORAGE.....	153			
21.1	Storage	153			
21.2	Preparing for use after storage.....	153			
22	TROUBLESHOOTING	154			
23	TECHNICAL DATA.....	156			
23.1	Engine	156			
23.2	Engine tightening torques	157			
23.3	Capacities	159			
23.3.1	Engine oil	159			
23.3.2	Coolant	159			
23.3.3	Fuel	160			
23.4	Chassis	160			
23.5	Electrical system.....	161			
23.6	Tires	161			
23.7	Fork.....	161			
23.8	Shock absorber	162			
23.9	Chassis tightening torques	163			
24	DECLARATIONS OF CONFORMITY	167			
24.1	Declarations of conformity	167			
24.2	Country-specific declarations of conformity (KTM RACE ON system 1).....	167			
24.3	Country-specific declarations of conformity (KTM RACE ON system 2).....	168			
24.4	Country-specific declarations of conformity (CCU-2)	168			
25	OPEN SOURCE.....	169			
25.1	Information on open source software	169			
26	SUBSTANCES	170			
27	AUXILIARY SUBSTANCES	172			
28	STANDARDS	173			
29	INDEX OF SPECIAL TERMS	174			
30	LIST OF ABBREVIATIONS.....	175			
31	LIST OF SYMBOLS.....	176			
31.1	Red symbols.....	176			

1 MEANS OF REPRESENTATION

1.1 Symbols used

The meaning of specific symbols is described below.



Indicates an expected reaction (e.g. of a work step or a function).



Indicates an unexpected reaction (e.g. of a work step or a function).



All work marked with this symbol requires specialist knowledge and technical understanding. In the interest of your own safety, have these jobs performed by an authorized KTM workshop! Your motorcycle will be optimally cared for there by specially trained experts using the auxiliary tools required.



Indicates a page reference (more information is provided on the specified page).



Indicates information with more details or tips.



Indicates the result of a testing step.



Indicates a voltage measurement.



Indicates a current measurement.



Indicates the end of an activity, including potential rework.

1.2 Formats used

The typographical formats used in this document are explained below.

Proprietary name

Indicates a proprietary name.

Name®

Indicates a protected name.

Brand™

Indicates a brand available on the open market.

Underlined terms

Refer to technical details of the vehicle or indicate technical terms, which are explained in the glossary.

2.1 Use definition – intended use

The vehicle is designed and constructed to withstand the usual demands of regular traffic and use on gentle terrain (unpaved roads). This vehicle is not suitable for use on race tracks.



Info

This vehicle is only authorized for operation on public roads in its homologated version.

2.2 Misuse

The vehicle must only be used as intended.

Dangers can arise for people, property and the environment through use not as intended.

Any use of the vehicle beyond the intended and defined use constitutes misuse.

Misuse also includes the use of operating and auxiliary fluids which do not meet the required specification for the respective use.

2.3 Safety advice

A number of safety instructions need to be followed to operate the product described safely. Therefore read this instruction and all further instructions included carefully. The safety instructions are highlighted in the text and are referred to at the relevant passages.



Info

Various information and warning labels are attached in prominent locations on the product described. Do not remove any information or warning labels. If they are missing, you or others may not recognize dangers and may therefore be injured.

2.4 Degrees of risk and symbols



Danger

Identifies a danger that will immediately and invariably lead to fatal or serious permanent injury if the appropriate measures are not taken.



Warning

Identifies a danger that is likely to lead to fatal or serious injury if the appropriate measures are not taken.



Caution

Identifies a danger that may lead to minor injuries if the appropriate measures are not taken.

Note

Identifies a danger that will lead to considerable machine and material damage if the appropriate measures are not taken.



Note

Indicates a danger that will lead to environmental damage if the appropriate measures are not taken.

2.5 Tampering warning

Tampering with the noise control system is prohibited. Federal law prohibits the following acts or the causing thereof:

- 1 The removal or rendering inoperative by any person other than for purposes of servicing, repair, or replacement, of any device or element of design incorporated into any new vehicle for the purpose of noise control prior to its sale or delivery to the ultimate purchaser or while it is in use, or
- 2 the use of the vehicle after such device or element of design has been removed or rendered inoperative by any person.

Among those acts presumed to constitute tampering are the acts listed below:

- 1 Removal or puncturing of the main silencers, baffles, header pipes or any other components which conduct exhaust gases.
- 2 Removal or puncturing of parts of the intake system.
- 3 Lack of proper maintenance.
- 4 Replacing moving parts of the vehicle, or parts of the exhaust system or intake system, with parts other than those specified by the manufacturer.

2.6 Safe operation



Danger

Danger of accidents A rider who is not fit to ride poses a danger to him or herself and others.

- Do not operate the vehicle if you are not fit to ride due to alcohol, drugs or medication.
- Do not operate the vehicle if you are physically or mentally impaired.



Danger

Danger of poisoning Exhaust gases are toxic and inhaling them may result in unconsciousness and death.

- Always make sure there is sufficient ventilation when running the engine.
- Use effective exhaust extraction when starting or running the engine in an enclosed space.



Warning

Danger of burns Some vehicle components become very hot when the vehicle is operated.

- Do not touch any parts such as the exhaust system, radiator, engine, shock absorber, or brake system before the vehicle parts have cooled down.
- Let the vehicle parts cool down before you perform any work on the vehicle.

Only operate the vehicle when it is in perfect technical condition, in accordance with its intended use, and in a safe and environmentally compatible manner.

The vehicle should only be used by trained persons. An appropriate driver's license is needed to ride the vehicle on public roads.

Have malfunctions that impair safety promptly eliminated by an authorized KTM workshop.

Adhere to the information and warning labels on the vehicle.

2.7 Protective clothing



Warning

Risk of injury Missing or poor protective clothing presents an increased safety risk.

- Wear appropriate protective clothing such as helmet, boots, gloves as well as trousers and a jacket with protectors on all rides.
- Always wear protective clothing that is in good condition and meets the legal regulations.

In the interest of your own safety, KTM recommends that you only operate the vehicle while wearing protective clothing.

2.8 Work rules

Unless specified otherwise, the ignition must be turned off during all work (models with ignition lock, models with remote key) or the engine must be at a standstill (models without ignition lock or remote key).

Special tools are necessary for certain tasks. The tools are not a component of the vehicle, but can be ordered using the number in parentheses. Example: bearing puller (15112017000)

During assembly, use new parts to replace parts which cannot be reused (e.g. self-locking screws and nuts, expansion screws, seals, sealing rings, O-rings, pins, and lock washers).

In the case of certain screws, a screw adhesive (e.g. **Loctite**®) is required. Observe the manufacturer's instructions.

If thread locker (e.g., **Precote**®) has already been applied to a new part, do not apply any additional thread locker. After disassembly, clean the parts that are to be reused and check them for damage and wear. Change damaged or worn parts.

After completing a repair or service work, check the operating safety of the vehicle.

2.9 Environment

If you use your motorcycle responsibly, you can ensure that problems and conflicts do not occur. To protect the future of the motorcycle sport, make sure that you use your motorcycle legally, display environmental consciousness, and respect the rights of others.

When disposing of used oil, other operating and auxiliary fluids, and used components, comply with the laws and regulations of the respective country.

Because motorcycles are not subject to the EU regulations governing the disposal of used vehicles, there are no legal regulations that pertain to the disposal of an end-of-life motorcycle. Your authorized KTM dealer will be glad to advise you.

2.10 Owner's Manual

Read this owner's manual carefully and completely before making your first trip. The Owner's Manual contains useful information and many tips on how to operate, handle, and service your motorcycle. This is the only way to find out how best to customize the vehicle for your own use and how you can protect yourself from injury.



Tip

Store the Owner's Manual on your terminal device, for example, so that you can read it whenever you need to.

If you would like to know more about the vehicle or have questions on the material you read, please contact an authorized KTM dealer.

The Owner's Manual is an important component of the vehicle. If the vehicle is sold, the Owner's Manual must be downloaded again by the new owner.

The Owner's Manual can be downloaded several times using the QR code or the link on the delivery certificate.

The Owner's Manual is also available for download from your authorized KTM dealer and on the KTM website. A printed copy can also be ordered from your authorized KTM dealer.

International KTM Website: <http://www.ktm.com>

3.1 Manufacturer warranty, implied warranty

The work prescribed in the service schedule must only be carried out in an authorized KTM workshop and confirmed in the **KTM Dealer.net**, as otherwise all warranty claims will be void. Damage or secondary damage caused by tampering with and/or conversions on the vehicle are not covered by the manufacturer warranty.

3.2 Fuel, auxiliary substances



Note

Environmental hazard Improper handling of fuel is a danger to the environment.

- Do not allow fuel to enter the groundwater, the soil, or the sewage system.

Use fuels and auxiliary substances in accordance with the Owner's Manual and specification.

3.3 Spare parts, accessories

For your own safety, only use spare parts and accessory products that are approved and/or recommended by KTM and have them installed by an authorized KTM workshop. KTM accepts no liability for other products and any resulting damage or loss.

Certain spare parts and accessory products are specified in parentheses in the descriptions. Your authorized KTM dealer will be glad to advise you.

The current **KTM PowerParts** for your vehicle can be found on the KTM website.

International KTM Website: <http://www.ktm.com>

3.4 Service

A prerequisite for perfect operation and the prevention of premature wear is that the service, care, and tuning work on the engine and chassis are properly carried out as described in the Owner's Manual. Poor suspension settings can result in damage to the components.

Using the motorcycle in extreme operating conditions, e.g. on very muddy and wet roads or in a dusty and dry environment, can lead to above-average wear of components, such as the drive train, brakes or air filter. For this reasons, it may be necessary to service or replace worn parts before the interval listed in the service schedule is reached.

It is imperative that you adhere to the stipulated run-in times and service intervals. If you observe these exactly, you will ensure a much longer service life for your motorcycle.

3.5 Figures

The figures contained in the manual may depict special equipment.

In the interest of clarity, some components may be shown disassembled or may not be shown at all. It is not always necessary to disassemble the component to perform the activity in question. Please follow the instructions in the text.

3.6 Customer service

Your authorized KTM dealer will be happy to answer any questions you may have on your vehicle and KTM.

A list of authorized KTM dealers can be found on the KTM website.

International KTM Website: <http://www.ktm.com>

4.1 View of vehicle, front left (example)



E02328-10

- ① Socket for electrical accessories (📖 p. 23)
- ② Clutch lever (📖 p. 15)
- ③ Seat release (📖 p. 26)
- ④ Grab handles (📖 p. 26)
- ⑤ Luggage rack plate (📖 p. 26)
- ⑥ Passenger foot pegs (📖 p. 27)
- ⑦ Center stand (📖 p. 28)
- ⑧ Rider footrests (📖 p. 64)
- ⑨ Side stand (📖 p. 28)
- ⑩ Shift lever (📖 p. 27)
- ⑪ Engine oil level viewer
- ⑫ Fuel petcocks (📖 p. 24)

4.2 View of vehicle, rear right (example)

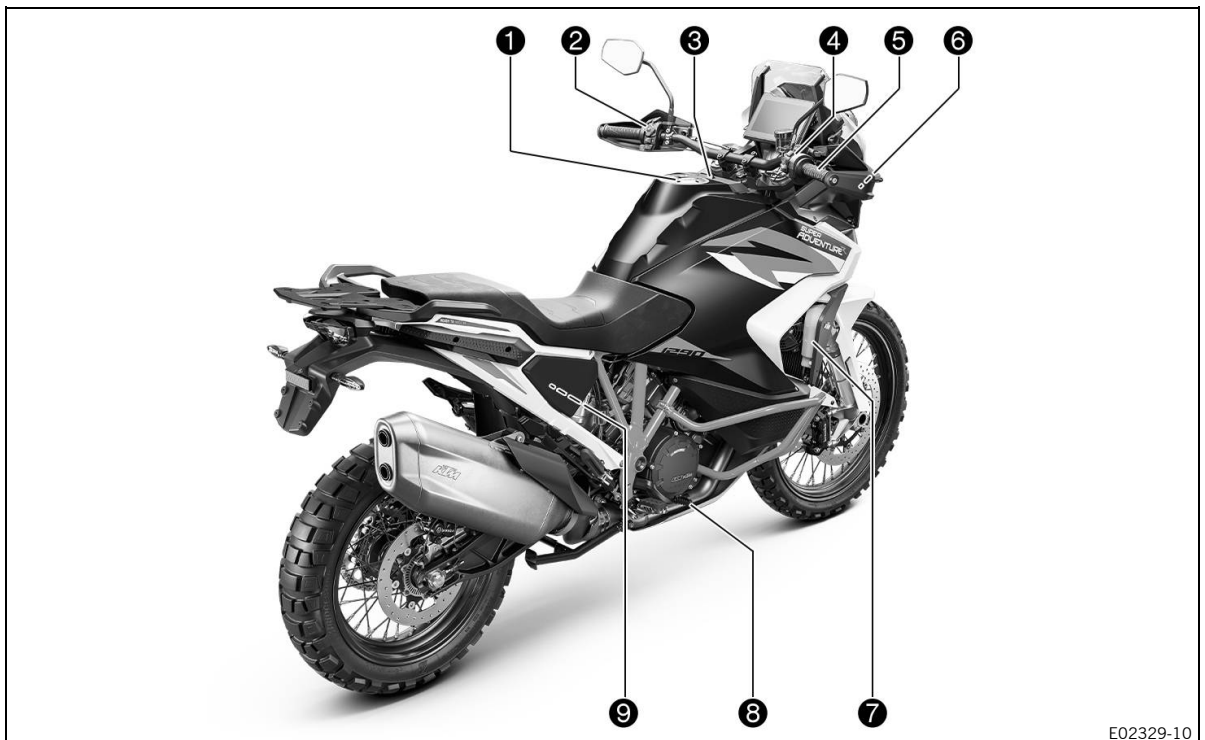

- ❶ Fuel tank filler cap
- ❷ Combination switch, left side (📖 p. 15)
- ❸ Storage compartment
- ❹ Combination switch, right (📖 p. 19)
- ❺ Throttle grip (📖 p. 15)
- ❻ Handbrake lever (📖 p. 15)
- ❼ Cooling system compensating tank
- ❽ Foot brake lever (📖 p. 27)
- ❾ Emergency seat release (📖 p. 26)

5.1 Vehicle identification number

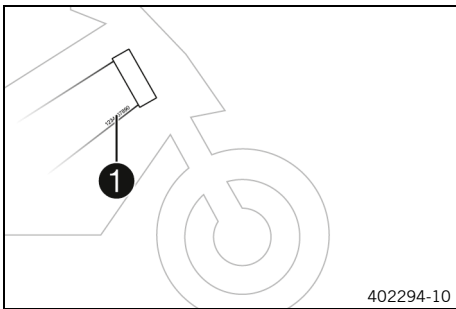

The vehicle identification number **1** is stamped on the bottom right of the frame behind the steering head.
The vehicle identification number is also shown on the type label.

5.2 Type label

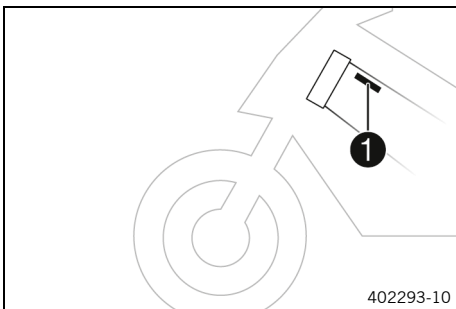

Type label **1** is affixed to the top left of the frame behind the steering head.

5.3 Engine number

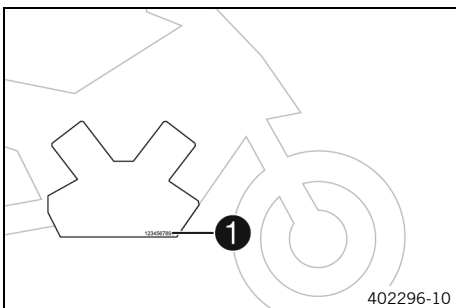

The engine number **1** is stamped on the right side of the engine.

5.4 Fork part number

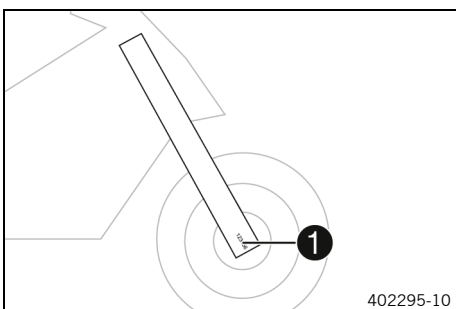

The fork part number **1** is stamped on the inner side of the fork stub.

5.5 Shock absorber article number

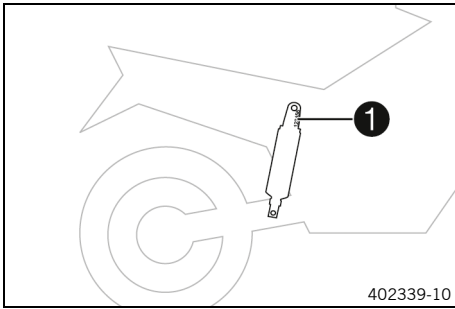

The shock absorber article number **1** is stamped on the top of the shock absorber.

5.6 Steering damper article number

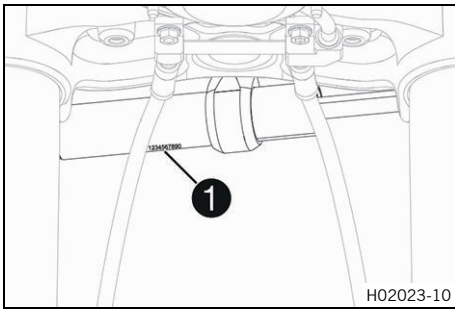

Steering damper article number **1** is embossed on the underside of the steering damper.

6.1 Clutch lever

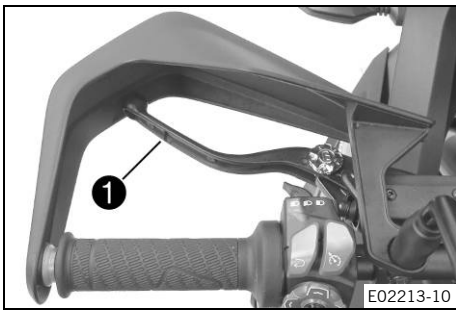

The clutch lever ① is fitted on the left side of the handlebar. The clutch is hydraulically operated and self-adjusting.

6.2 Handbrake lever



Handbrake lever ① is located on the right side of the handlebar. The hand brake lever is used to activate both the front brake and rear brake at the same time.

i Info

When the ABS mode **Offroad** is switched on, only the front brake is applied.

6.3 Throttle grip

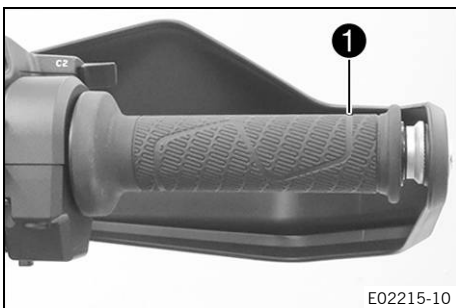

The throttle grip ① is fitted on the right side of the handlebar.

6.4 Combination switch, left side

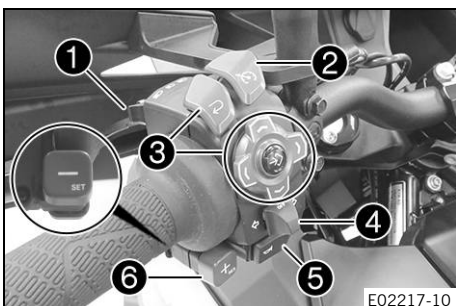

The left combination switch is fitted on the left side of the handlebar.

Overview of the left combination switch

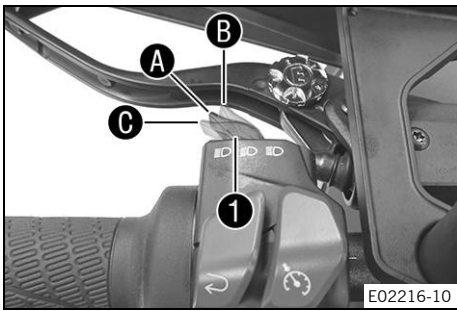

- ① Light switch (📖 p. 16)
- ② Cruise control buttons (📖 p. 16)
- ③ Menu switches (📖 p. 18)
- ④ Turn signal switch (📖 p. 18)
- ⑤ Horn button (📖 p. 19)
- ⑥ +RES/-SET button (📖 p. 18)

6.5 Light switch



The light switch **1** is fitted on the combination switch on the left.

Possible states

	Low beam on – Light switch in position A . In this position, the low beam and the tail light are switched on.
	High beam on – Push the light switch to position B . In this position, the high beam and the tail light are switched on.
	Headlight flasher – Push the light switch into position C .

6.6 Cruise control buttons

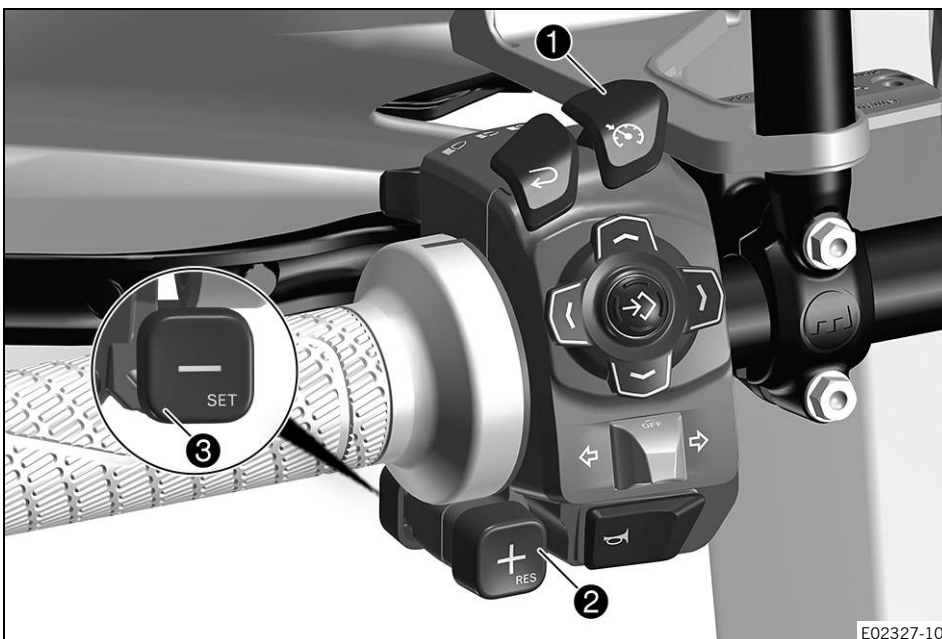

The cruise control buttons **1**, **2** and **3** of the are located on the left side of the combination switch.

Possible states

- cruise control system button  pressed briefly – Cruise control function is switched on or off. The operating mode is displayed in the combination instrument.
- Button **+RES** pressed briefly – The last saved speed is reapplied. Every subsequent brief pressing increases the target speed by 1 km/h or 1 mph.
- Button **+RES** pressed and held – The target speed increases in increments of 5 km/h or 5 mph.
- Button **-SET** pressed briefly – The cruise control system function is activated and the current speed is maintained. Every subsequent brief press reduces the target speed by 1 km/h or 1 mph.
- Button **-SET** pressed and held – The target speed decreases in increments of 5 km/h or 5 mph.



Warning

Danger of accidents The cruise control system function is not suitable for all riding situations.

The selected target speed will not be reached, if the engine power is not sufficient for a gradient.

The selected target speed will be exceeded if the engine braking effect is not sufficient on an incline.

- Do not use the cruise control systems function on winding roads.
- Do not use the cruise control systems on slippery road surfaces (e.g. rain, ice or snow), where there is poor visibility or on unpaved surfaces (e.g. sand, stones or gravel).
- Do not use the cruise control systems function if the traffic does not permit a constant speed.

Functions of cruise control:

- After activation of the cruise control system function, the throttle grip can be turned back to the basic position. The selected speed will be maintained.
- If no cruise speed has yet been saved, this can be saved using the **+RES** button.
- If the target speed is exceeded for less than 10 seconds by turning the throttle grip, the cruise control system remains activated.
- If the cruise speed differs from the current speed by more than 10 km/h or 10 mph, e.g. when passing another vehicle, the current speed is stored as the cruise speed by pressing the **-SET** button briefly.
- If there is a steep downhill slope and the engine braking effect is not sufficient to maintain the set cruise speed, the system brakes actively.
- If the set cruise speed is significantly below the current speed, the system brakes actively in order to reach the cruise speed.
- The speed is reduced as the lean angle increases.

The cruise control function is deactivated when one of the following events occurs (switch-off conditions):

- Operating the handbrake lever.
- Operating the rear brake lever.
- Operating the clutch lever for more than 2.5 seconds.
- Closing the throttle beyond the basic position.
- Slip at the rear wheel or the front wheel lifting and thus associated regulation of the motorcycle traction control (**MTC**) for longer than 1 second.
- Control of ABS for more than 1 second.
- A malfunction occurring, which impairs the cruise control system function.
- Exceeding the cruise speed for more than 10 seconds when passing a vehicle.
- Lean angles exceeding 41°.
- Engine speed below 1,500 rpm.
- Engaging the first gear or shifting transmission to the neutral position.
- Motorcycle traction control (**MTC**) is switched off.
- **ABS** mode **Offroad** is activated.

The cruise control can only be activated if the following conditions are met (switching conditions):

- Motorcycle traction control (**MTC**) is activated.
- No strong acceleration.
- Do not exceed a lean angle greater than 41°.
- 2nd, 3rd, 4th, 5th or 6th gear is engaged.
- Vehicle speed between 30 and 200 km/h or between 20 and 125 mph.
- **ABS** mode **Road** is active.

6.7 +RES/-SET button

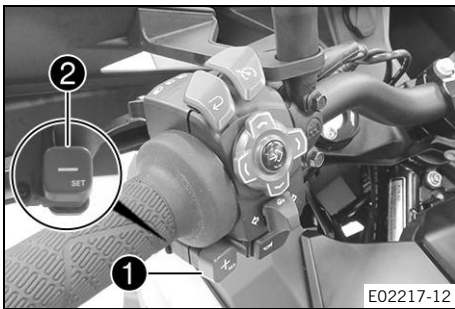

The **+RES** button **1** is fitted on the front left of the handlebar. The **-SET** button **2** is fitted on the rear left of the handlebar.

i Info

The **+RES** and **-SET** buttons are used to control the cruise control when the cruise control function is activated. If the cruise control function is deactivated, the buttons **+RES** and **-SET** on the main display or in the **Slip Adjuster** menu can be used to adjust the **Slip Adjuster**.

6.8 Menu switches

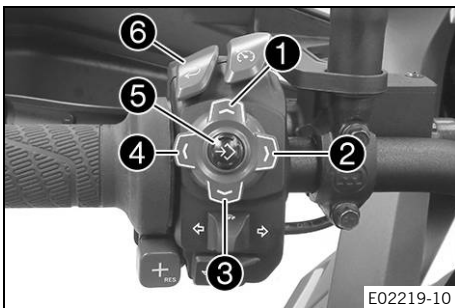

The menu switches are fitted in the middle of the left combination switch.



- Button **1** is the **UP** button.
- Button **2** is the **RIGHT** button.
- Button **3** is the **DOWN** button.
- Button **4** is the **LEFT** button.
- Button **5** is the **SET** button.
- Button **6** is the **BACK** button.

6.9 Turn signal switch



Turn signal switch **1** is fitted on the combination switch on the left.

Possible states

	Turn signal off – Push the turn signal switch toward the switch housing.
	Left turn signal, on – Turn signal switch pressed to the left. The turn signal switch returns automatically to the central position after use.
	Right turn signal, on – Turn signal switch pressed to the right. The turn signal switch returns automatically to the central position after use.

i Info

An automatic turn signal switch-off function (**ATIR**) is available as a software feature.

The **ATIR** function uses a time and distance counter. If the turn signal has been on for at least 10 seconds and 150 meters of riding distance, the turn signal is switched off.

If the vehicle is stationary, both counters are stopped. If the turn signal switch is reactivated, both counters are reset.

6.10 Horn button

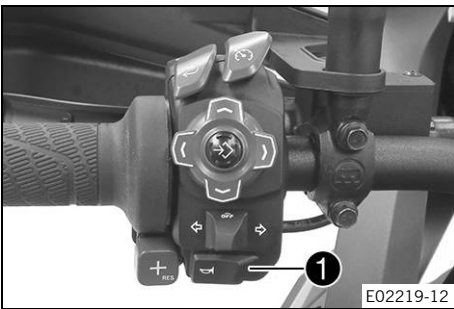

Horn button ① is fitted on the left side of the handlebar.

Possible states

- The horn button is in the basic position
- The horn button is pressed – The horn is operated in this position.

6.11 Combination switch, right

The right combination switch is fitted on the right side of the handlebar.

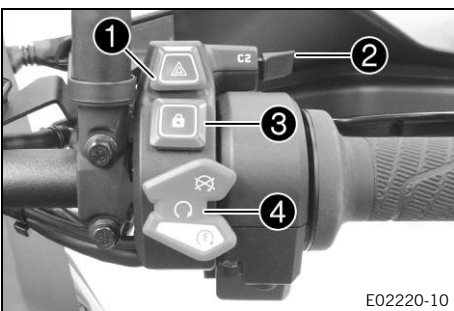

Overview of the right combination switch

- ① Hazard warning flasher switch (p. 19)
- ② C1 and C2 switch (p. 20)
- ③ RACE ON button (p. 20)
- ④ Start button/emergency OFF switch (p. 20)

6.12 Hazard warning flasher switch

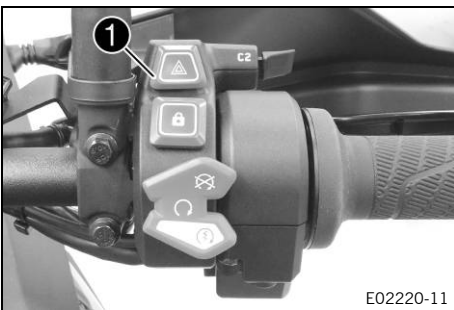

The hazard warning flasher switch ① is fitted on the right side of the combination switch. The hazard warning flasher is used to indicate emergency situations.

i Info

The hazard warning flasher can be activated or deactivated while the ignition is switched on or up to 60 seconds after the ignition is switched off. Only keep the hazard warning flasher activated as long as necessary as it depletes the 12-V battery.

Possible states

↔	Hazard warning flasher on – All four turn signals and the green turn signal indicator lights in the combination instrument flash.
---	---

6.13 C1 and C2 switch

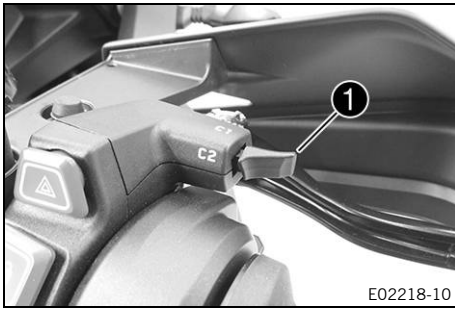

The C1 and C2 switch is fitted on the right of the combination switch.



Info

The C1 and C2 switch enables quick access to various menus.

The C1 and C2 switch can be freely configured in the **Custom Switch** menu.

6.14 RACE ON button

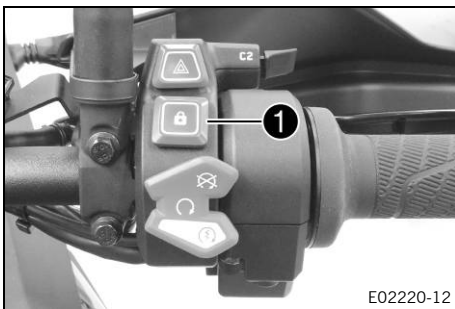

The RACE-ON button ① is fitted on the right side of the combination switch.





Info

The RACE-ON button performs the ignition lock function on this vehicle.

The steering can only be locked if the handlebar is turned fully to the left.

Possible states



- RACE-ON button  in the basic position.
- RACE-ON button  pressed briefly – Pressing briefly switches the ignition on and unlocks the steering lock or switches the ignition off. The RACE ON indicator light lights up briefly once for confirmation.
- RACE-ON button  pressed and held – Pressing and holding switches the ignition off and locks the steering lock.

6.15 Start button/emergency OFF switch



The start button/emergency OFF switch ① is fitted on the right side of the combination switch.

Possible states

	Start button/emergency OFF switch off (upper position) – In this position, the ignition circuit is interrupted, a running engine stops, and a non-running engine cannot be started. A message appears on the display.
	Start button/emergency OFF switch on (middle position) – This position is required for operation; the ignition circuit is closed.
	Starter motor on (lower position) – In this position, the starter motor is actuated.

6.16 Steering lock (antenna)

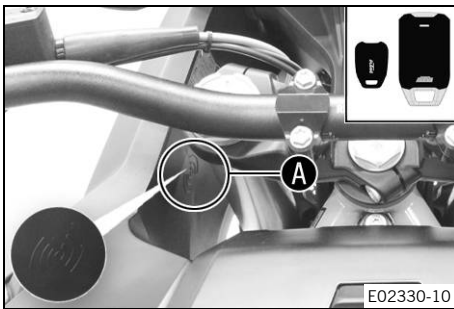

On this vehicle, the ignition and steering lock is replaced by a remote key with transponder (RACE ON key (📖 p. 21)). In order to activate the steering lock, the handlebar must be turned fully to the left. The steering is locked and unlocked electromechanically via the RACE-ON button (🔑 (📖 p. 20)). If the battery voltage of the RACE ON key is too low, hold the RACE ON key or the RACE ON chip in the **A** area on the motorcycle and repeat starting.

i Info
As soon as the engine has been started, safely stow away the RACE ON key or the RACE ON chip again.

Possible states

- Ignition off, steering locked – In this operating mode, the ignition circuit is interrupted and the steering locked.
- Ignition off, steering unlocked – In this operating mode, the ignition circuit is interrupted and the steering unlocked.
- Ignition on, steering unlocked – In this operating mode, the ignition circuit is closed and the steering unlocked.

6.17 Immobilizer



The electronic immobilizer secures the vehicle against unauthorized use. The immobilizer is activated and the engine electronics are locked as soon as the ignition is switched off via the RACE-ON button (🔑 (📖 p. 20)). The RACE ON indicator light **1** can indicate malfunctions by flashing. If the optional alarm system is installed, the RACE ON indicator light **1** flashes red when the alarm system is switched on.

6.18 RACE ON key

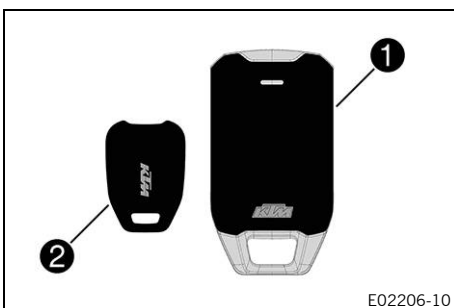

On this vehicle, the RACE ON key **1** performs all the functions of the conventional ignition key. If the battery voltage of the RACE ON key is too low, the vehicle can be started by holding the RACE ON key directly to the vehicle antenna (📖 p. 21). The RACE ON chip **2** is only intended for situations in which the RACE ON key is not available. Like the RACE ON key, the RACE ON chip can be used to start the vehicle by holding the chip directly to the vehicle antenna (📖 p. 21).

i Info
The ignition keys contain electronic components. Always maintain a distance of several centimeters to other devices with electronic components.

A lost ignition key must be deactivated by an authorized KTM workshop to prevent unauthorized persons from operating the vehicle.

The ignition keys supplied are activated when delivered.

Up to four ignition keys in total can be activated by an authorized KTM workshop.

6.19 Anti-relay attack (ARA)

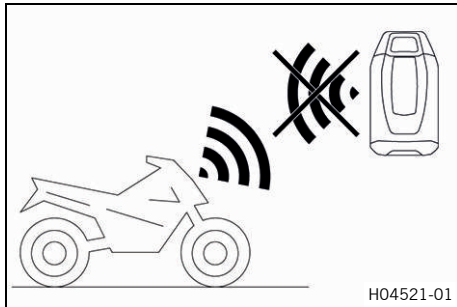

The RACE ON key has anti-relay attack mode that enhances security against theft.

The **Anti Relay Attack (ARA)** function can be activated or deactivated on the dash. If the function is activated, the remote response of the RACE ON key is deactivated 5 minutes after the ignition is switched off. The dash displays whether the anti-relay attack mode in the ignition key has been successfully activated when the ignition is switched off.

Even if the RACE ON key is within range, the vehicle cannot be contactlessly started with the RACE ON key after the period has expired. The same blink code on the dash is displayed as if the RACE ON key were out of range.

This prevents another person from starting the vehicle at an extended range, although the owner and RACE ON key are not in the vicinity of the vehicle.

i Info

If the RACE ON key battery has been changed, the anti-relay attack mode in the RACE ON key is also deactivated if the **Anti Relay Attack** function is active on the dash.

The anti-relay attack mode in the RACE ON key is not activated until the next time the ignition is switched off.

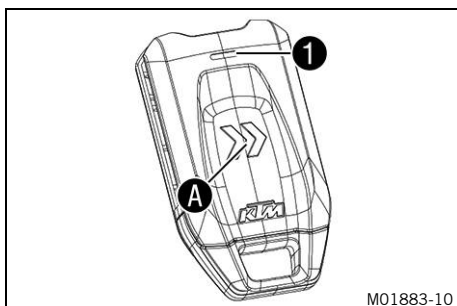

A button is located in the **A** area of the RACE ON key. When this button is pressed and the **1** LED flashes three times, the RACE ON key's anti-relay attack mode will be deactivated for 10 minutes, allowing the vehicle's contactless start.

i Tip

This function can be used, for example, before the RACE ON key is stored in the rider's motorcycle clothing.

If no vehicle start occurs within this period, the RACE ON key's anti-relay attack mode is reactivated.

Regardless of the anti-relay attack mode, the vehicle can always be started by holding the RACE ON key or the RACE ON chip directly to the vehicle antenna (📖 p. 21).

i Info

In this case, the anti-relay attack mode will not be activated the next time the ignition is switched off.

The vehicle only activates the anti-relay attack mode when the ignition is switched off in one RACE ON key each.

It is recommended to carry only one RACE ON key at a time, as it cannot be predicted in which RACE ON key the anti-relay attack mode will be activated.

6.20 Socket for electrical accessories

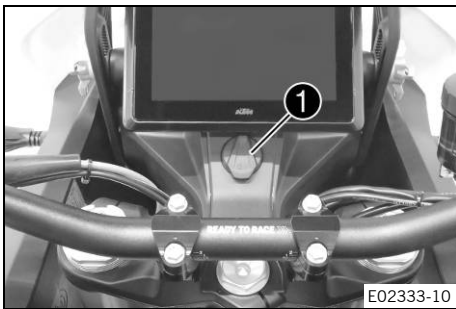

Socket ① for electrical accessories is fitted in front of the upper triple clamp. It is connected to the permanent positive and is fuse-protected.

Socket for electrical accessories	
Voltage	12 V
Maximum current consumption	10 A

6.21 USB socket

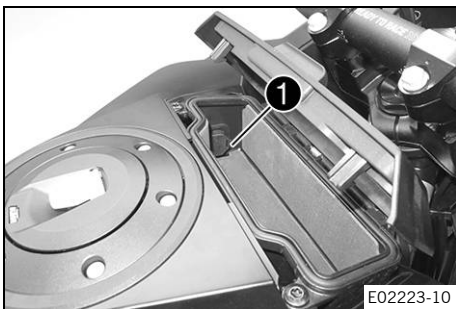

A USB socket ① is located in the storage compartment for supplying power to external devices. The USB socket is activated when the ignition is switched on.

USB socket	
Voltage	5 V
Maximum current consumption	2.1 A

6.22 Opening fuel tank filler cap



Danger

Fire hazard Fuel is highly flammable.

The fuel in the fuel tank expands when warm and can escape if overfilled.

- Do not fuel the vehicle in the vicinity of open flames or lit cigarettes.
- Switch off the engine for refueling.
- Make sure that no fuel is spilled; particularly not on hot parts of the vehicle.
- If any fuel is spilled, wipe it off immediately.
- Observe the specifications for refueling.



Warning

Danger of poisoning Fuel is poisonous and a health hazard.

- Avoid skin, eye and clothing contact with fuel.
- Immediately consult a doctor if you swallow fuel.
- Do not inhale fuel vapors.
- In case of skin contact, rinse the affected area with plenty of water.
- Rinse the eyes thoroughly with water, and consult a doctor in case of fuel contact with the eyes.
- Change your clothing in case of fuel spills on them.
- Keep fuels correctly in a suitable canister, and out of the reach of children.



Note

Environmental hazard Improper handling of fuel is a danger to the environment.

- Do not allow fuel to enter the groundwater, the soil, or the sewage system.

Condition

The motorcycle is stationary.

The engine is off.
The ignition has been switched on or off for less than 1 minute.

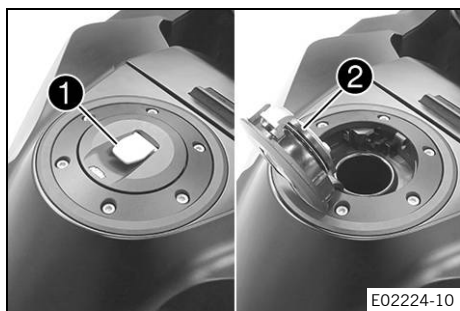

- Fold up cover **1** slowly.
- ✓ The fuel tank filler cap is unlocked.
- Fold up fuel tank filler cap **2**.

6.23 Closing the fuel tank filler cap

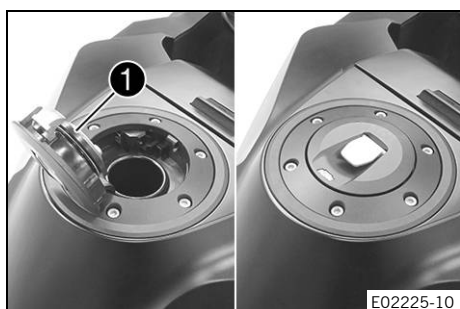

Warning

Fire hazard Fuel is highly flammable, toxic and a health hazard.

- Check that the fuel tank filler cap is locked correctly after closing.
- Change your clothing if fuel spills on them.
- Rinse the affected area immediately with plenty of water in the event of contact with the skin.

- Fold down fuel tank filler cap **1** and push it down.
- ✓ The fuel tank filler cap locks audibly in place.

6.24 Fuel petcocks

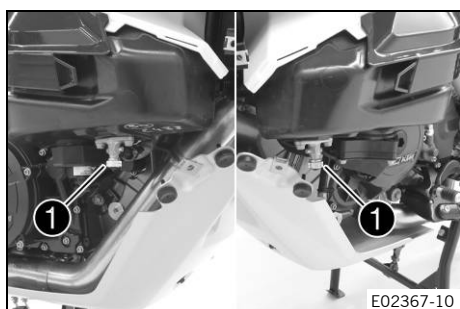

A fuel petcock **1** is located on each side of the fuel tank. The lower fuel tank fairing must be removed to reach the fuel petcocks.



Info

The fuel petcocks must always be open during operation. The fuel petcocks are only closed to remove the fuel tank.

Possible states

- Fuel petcocks are closed – Level equalization cannot take place and the fuel supply to the throttle valve body is shut off.
- Fuel petcocks are open – Level equalization can take place and the fuel supply to the throttle valve body is open.

6.25 Opening storage compartment

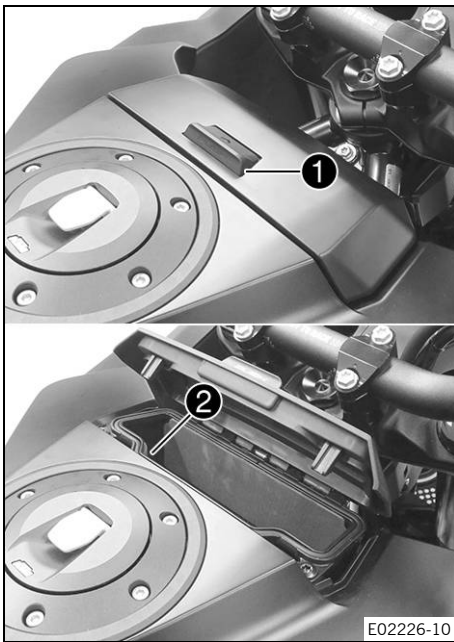

- Push the ① lock forwards.
- Open storage compartment.



Info

A USB socket ② (🔌 p. 23) is located in the storage compartment for supplying power to external devices.



6.26 Closing storage compartment

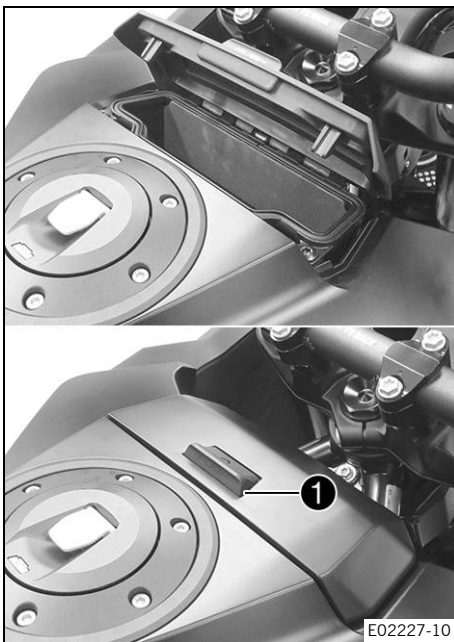

- Close storage compartment.
- Make sure that the ① lock engages.



6.27 Seat release



Button **1** for the seat release is located on the left side of the vehicle below the seat.
 The seat release button only functions if the motorcycle is stationary, the engine is switched off and the ignition is switched on or has been switched off for less than 1 minute.
 If the seat release button is not working, the seat can be unlocked using the emergency seat release (📖 p. 26).

6.28 Emergency seat release

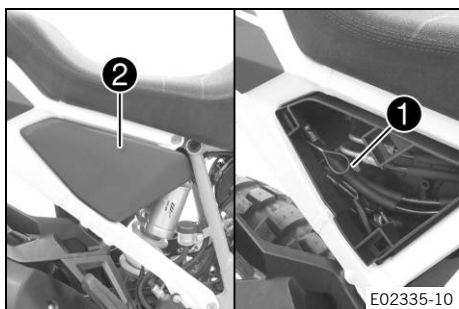

The emergency seat release **1** is located on the right side of the vehicle below the cover **2**.
 The emergency seat release is used if the seat release button does not work, e.g. because the 12 V battery is discharged.

6.29 Grab handles

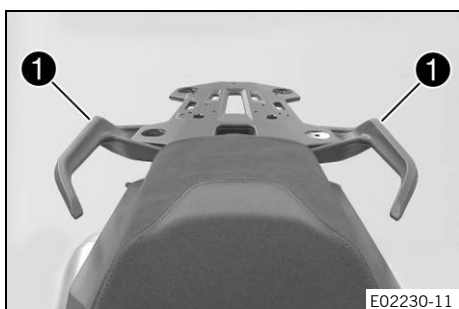

The passenger can hold onto the grab handles **1** during the trip.

6.30 Luggage rack plate

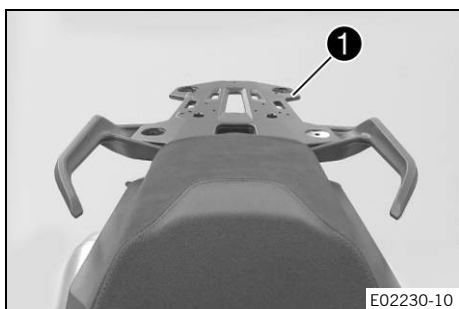

The luggage rack plate **1** is located behind the seat.
 The base plate of a luggage system (optional) can be attached to the luggage rack plate.
 The luggage rack plate may not be loaded with more than the specified weight.

Maximum permissible load on luggage rack plate	8 kg (18 lb.)
--	---------------

i Info

Note the information provided by the luggage manufacturer.

6.31 Passenger foot pegs

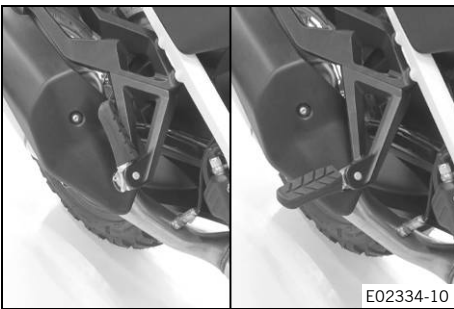

The passenger foot pegs can be folded up and down.

Possible states

- Passenger foot pegs folded up – For operation without a passenger.
- Passenger foot pegs folded down – For operation with a passenger.

6.32 Shift lever

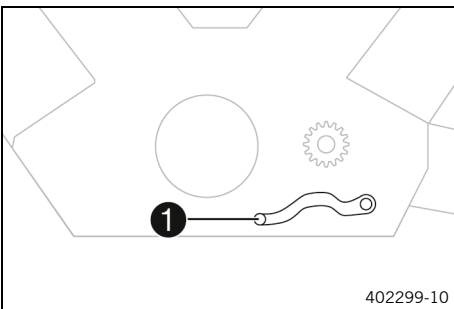

The shift lever ❶ is fitted on the left side of the engine.

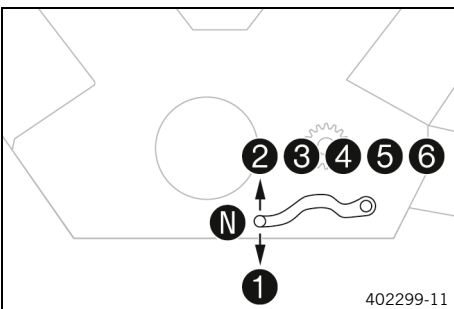

The gear positions can be seen in the figure.
The idle position is between first and second gears.

6.33 Foot brake lever

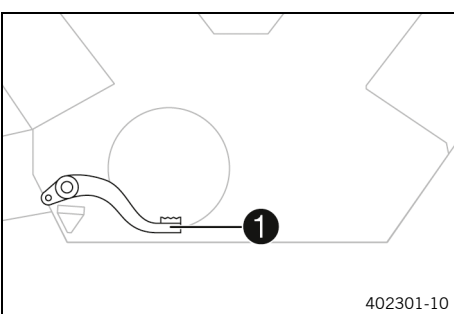

Foot brake lever ❶ is located in front of the right footrest.
The rear brake is activated using the foot brake lever.

6.34 Side stand

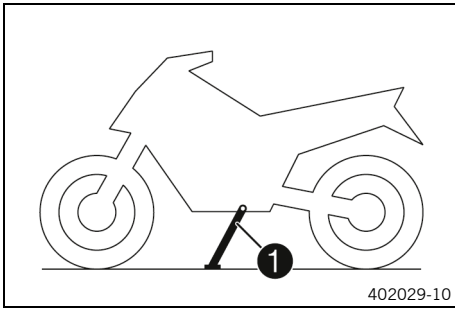

The side stand ① is located on the left of the vehicle.
The side stand is used for parking the motorcycle.

i Info

The side stand must be folded up during motorcycle use.
The side stand is coupled with the safety starting system.
See the instructions in the section on “Stopping, parking”.

Possible states

- Side stand folded out – The vehicle can be supported on the side stand. The safety starting system is active.
- Side stand folded in – This position is mandatory when riding the motorcycle. The safety starting system is inactive.

6.35 Center stand

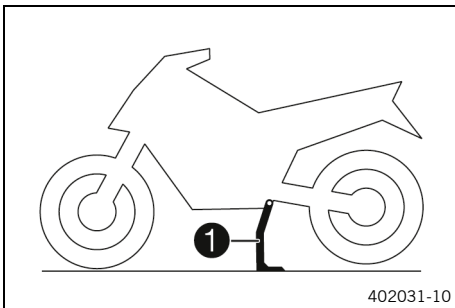

In addition to the side stand, the vehicle is equipped with a center stand ①.

7.1 Combination instrument



E02044-11

The combination instrument is attached in front of the handlebar.
The combination instrument is divided into two function areas.

① indicator lamps (p. 32)

Display ②



Warning

Danger of burns Parts of the combination instrument become very hot in certain situations. In particular, the display gets hot in ambient temperatures above 55 °C (131 °F), during extended stationary periods, e.g. at a traffic light, or in direct sunlight.

- Do not touch the combination instrument with bare hands in the situations referred to.
- Where appropriate protective clothing.
- If you have been burned, hold the area affected under lukewarm water immediately.

7.2 Activation and test



E02045-02

Activation

The combination instrument is activated when the ignition is switched on.



Info

The brightness of the displays is controlled by an ambient light sensor in the combination instrument.

Test

The welcome text appears on the display and the indicator lamps are briefly activated for a function check.

i Info

The malfunction indicator lamp always lights up as long as the engine is not running. If the engine is running and the malfunction indicator lamp lights up, stop (taking care not to endanger yourself or other road users in the process) and contact an authorized KTM workshop.

The oil pressure warning lamp always lights up as long as the engine is not running. If the engine is running and the oil pressure warning lamp lights up, stop immediately (taking care not to endanger yourself or other road users in the process) and switch off the engine.

The ABS warning lamp and TC indicator lamp light up until a speed of approx. 6 km/h (approx. 4 mph) or more has been reached.

7.3 Day-night mode



Day mode is shown in a bright color.



Night mode is shown in a dark color.

i Info

The ambient light sensor in the combination instrument measures the brightness of the environment and automatically switches the display to day or night mode. The display is brightened, darkened or switched to the other mode depending on the brightness measured by the ambient light sensor.

To prevent constant switching, automatic switching is slightly delayed.

In the **Display Theme** menu, the display mode can be changed manually between **AUTOMATIC** and **NIGHT**.

7.4 Warnings

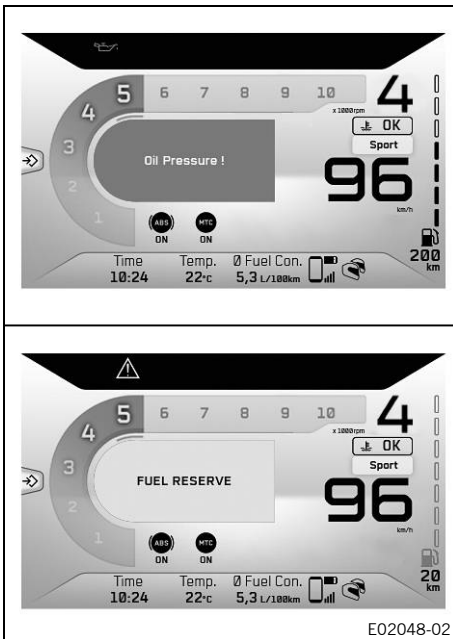

Warnings appear in the middle of the display; these are marked yellow or red depending on their relevance. Yellow warnings indicate malfunctions or information which require prompt intervention or an adjustment to the riding style. Red warnings indicate malfunctions or information which require immediate intervention.

i Info

Warnings can be hidden by pressing any button. All the existing warnings are displayed in the **Warnings** menu until they are no longer active.

7.5 Ice warning

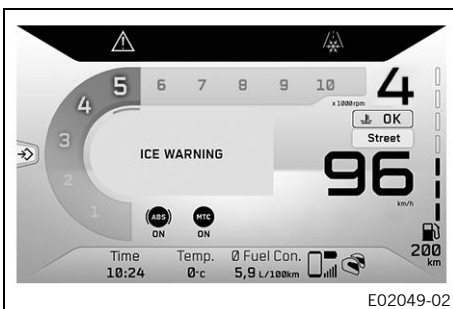

The ice warning ❄ goes on when there is an increased risk of ice on the roads.

The ice warning ❄ is shown in area ❶ of the display.

The ice warning ❄ appears on the display when the ambient temperature drops below the specified value.

Temperature	$\leq 4 \text{ }^{\circ}\text{C}$ ($\leq 39 \text{ }^{\circ}\text{F}$)
-------------	--

The ice warning ❄ goes out on the display when the ambient temperature rises above the specified value again.

Temperature	$\geq 6 \text{ }^{\circ}\text{C}$ ($\geq 43 \text{ }^{\circ}\text{F}$)
-------------	--

i Info

When the ice warning ❄ lights up, the warning **ICE WARNING** also appears.

7.6 Indicator lamps



The indicator lamps offer additional information about the operating state of the motorcycle. When the ignition is switched on, all indicator lamps light up briefly.

i Info







The malfunction indicator lamp always lights up as long as the engine is not running. If the engine is running and the malfunction indicator lamp lights up, stop (taking care not to endanger yourself or other road users in the process) and contact an authorized KTM workshop.

The oil pressure warning lamp always lights up as long as the engine is not running. If the engine is running and the oil pressure warning lamp lights up, stop immediately (taking care not to endanger yourself or other road users in the process) and switch off the engine.

The ABS warning light and TC indicator light light up until a speed of approx. 6 km/h (approx. 4 mph) or more has been reached.

Possible states

	RACE-ON indicator light lights up/flashes yellow/orange/red – Status or error messages relating to KTM RACE ON system/alarm system.
	The left turn signal indicator light flashes green with a steady rhythmic flash – The left turn signal is switched on.
	The high beam indicator light lights up blue – The high beam is switched on.
	The general warning lamp lights up yellow – A note/warning note on operating safety has been detected. This is also shown in the display.
	The ABS warning lamp lights up yellow – Status or error messages relating to <u>ABS</u> . The ABS warning lamp flashes if the ABS mode Offroad is enabled.

	TC indicator lamp lights up/flashes yellow – The MTC (📖 p. 143) is not enabled or is currently intervening. The TC indicator lamp also lights up if a malfunction is detected. Contact an authorized KTM workshop. The TC indicator lamp flashes if TC actively engages or if the HHC (📖 p. 74) (optional) is activated.
	Neutral position indicator is active in the display – The transmission is in the neutral position.
	The oil pressure warning lamp lights up red – The oil pressure is too low. Stop immediately, taking care not to endanger yourself or other road users in the process, and switch off the engine.
	The cruise control system indicator lamp lights up yellow – The cruise control system function is switched on, but cruise control is not activated.
	The cruise control system indicator lamp lights up green – The cruise control system function is switched on and cruise control is activated.
	Malfunction indicator lamp lights up yellow – The OBD has detected a malfunction in the vehicle electronics.
	The right turn signal indicator lamp flashes green with a steady rhythmic flash – The right turn signal is switched on.

7.7 Display



E02052-11

Info

The figure shows the start screen of the combination instrument. If the menu is opened, the speed and the selected gear are still displayed.

- ① Engine speed (📖 p. 35)
- ① Shift light (📖 p. 35)
- ① The shift light is integrated in the rpm gauge display.
- ② Unit for the engine speed display

7 COMBINATION INSTRUMENT

- ③ Gear indicator
- ④ Coolant temperature indicator (📖 p. 37)
- ⑤ Fuel level display (📖 p. 38)
- ⑥ **Ride-Mode** display (📖 p. 37)
- ⑦ Fuel range display
- ⑧ Unit of speed
- ⑨ Seat heating (optional) (📖 p. 37)
- ⑩ Heated grip (optional) (📖 p. 37)
- ⑪ **MTC** display (📖 p. 36)
- ⑫ **ABS** display (📖 p. 36)
- ⑬ **Favourites** display (📖 p. 38)
- SET**
- ⑭ Only shown when the menu overview is closed.
- ⑮ Speed (📖 p. 36)

7.8 Display Rally (optional)



i Info

The figure shows the start screen of the dash in active ride mode **Rally**. If the menu is opened, the speed and the selected gear are still displayed.

- ① Fuel level display
- ② Engine speed display
- ② Shift light
The shift light is integrated in the rpm gauge display.
- ③ Coolant temperature indicator
- ④ Speedometer

- ⑤ Unit of speed
- ⑥ Unit for the engine speed display
- ⑦ **Throttle Response** (optional) (📖 p. 144)
- ⑧ **ABS** indicator
- ⑨ **Favourites** indicator
- ⑩ Gear indicator
- ⑪ Fuel range display
- ⑫ **Slip Adjuster** (optional) (📖 p. 144)

7.9 Engine speed

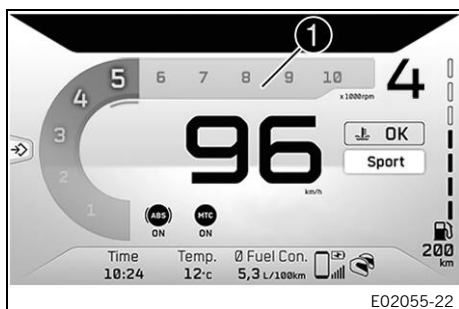

The engine speed is shown in area ① of the display.
The engine speed is measured in revolutions per minute.

7.10 Shift light

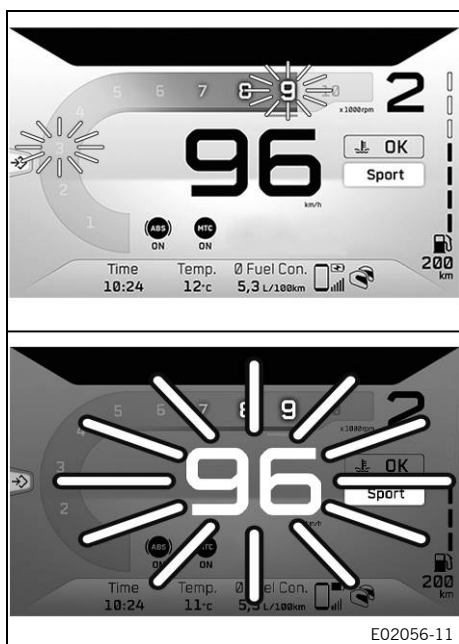

The shift light is integrated in the rpm gauge display.
The speed for the shift light can be set in the **Shift Light** menu. The shift warning light is always active during the running-in phase (up to 1,000 km / 621 mi). The shift warning light can only be deactivated, and the values for **RPM1** and **RPM2** can only be adjusted after this. At **RPM1**, the engine speed display flashes red and at **RPM2** the entire display flashes red.

i Info
In sixth-gear, the shift light is deactivated when the engine is warm after the first service.

Coolant temperature	≤ 35 °C (≤ 95 °F)
ODO	< 1,000 km (< 620 mi)
The shift warning light always lights up at	6,500 rpm
Coolant temperature	> 35 °C (> 95 °F)
ODO	> 1,000 km (> 620 mi)
RPM1 Engine speed display	flashes red
RPM2 entire display	flashes red

7.11 Cruise control indicator

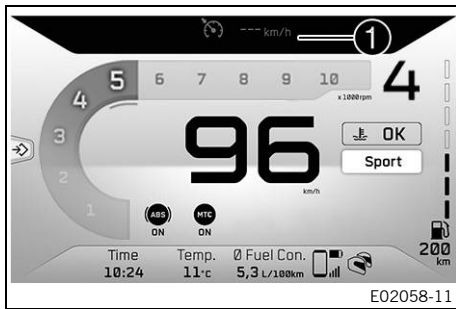

The operating state and active cruise control are shown in the **1** area of the display. Cruise control is operated using the cruise control tip switch (p. 16).

7.12 Speed

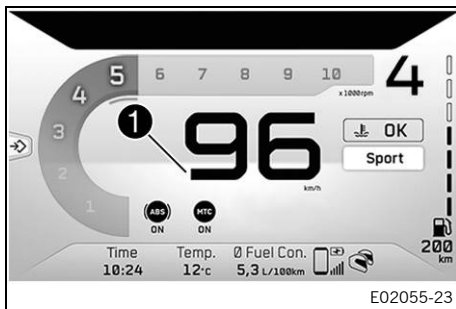

The speed is shown in area **1** of the display. The unit of speed can be configured in the **Units** menu. Speed is shown in kilometers per hour **km/h** or in miles per hour **mph**.

7.13 ABS display

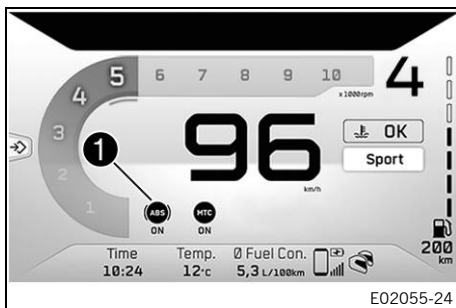

The ABS mode setting is shown in the **1** area of the display. The ABS can be configured in the **ABS** menu.

7.14 MTC display

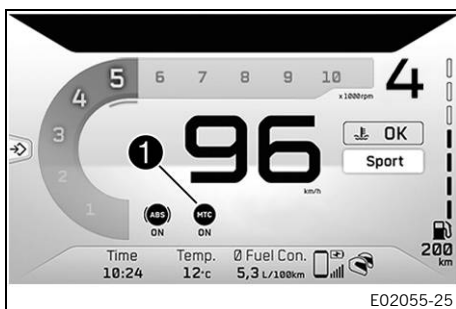

The **1** area of the display indicates whether **MTC** the system is switched on or off. The motorcycle traction control can be switched on or off in the **MTC** menu.

7.15 Ride-Mode display

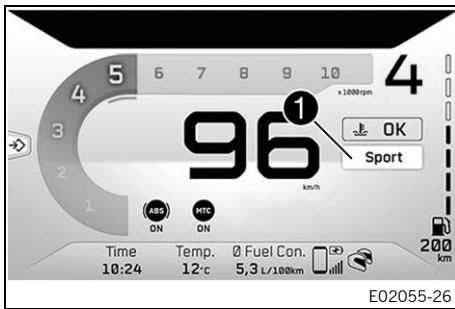

The **Ride Mode** setting is shown in area **1** of the display. The riding mode can be configured in the menu **Ride Mode**.

7.16 Coolant temperature indicator

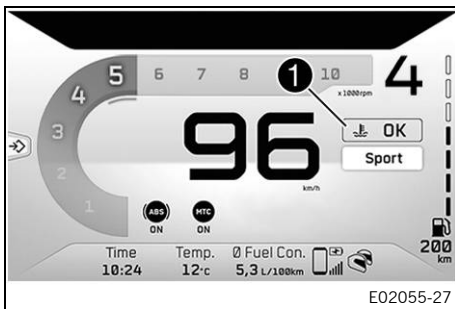

The coolant temperature is shown in area **1** of the display.

i Info

If the coolant temperature indicator shows **HOT**, the indicator also starts to flash.

Possible states

- The engine is cold – The coolant temperature indicator shows **LOW**.
- Engine warm – The coolant temperature indicator shows **OK**.
- Engine hot – The coolant temperature indicator shows **HOT**.

7.17 Heated grip (optional)

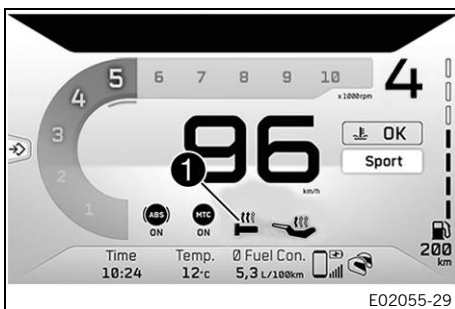

The status of the grip heater is shown in the **1** area of the display. The grip heater can be configured in the **Heating** menu.

7.18 Seat heating (optional)

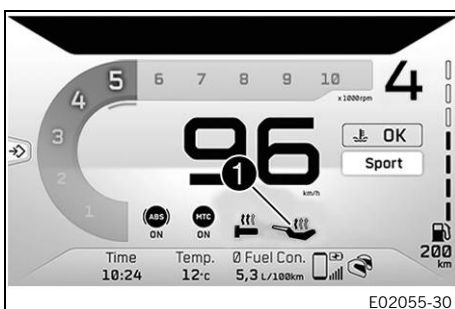

The status of the seat heating is shown in the **1** area of the display. The seat heating can be configured in the **Heating** menu.

i Info

The heating level for the passenger seat heating can be controlled by a switch next to the right grip handle.

7.19 Fuel level display

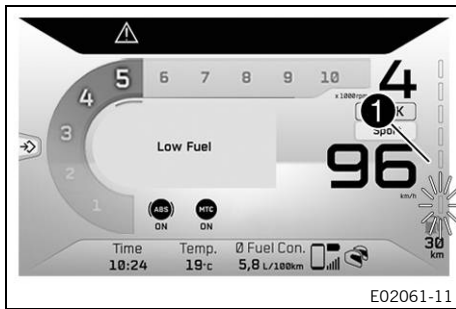

The fuel tank capacity is shown in the ❶ area of the display. The fuel level indicator consists of bars. The more bars are lit, the more fuel is in the fuel tank.

i Info

If the fuel level is getting low, the last bar flashes, the fuel symbol turns red and the **Low fuel** warning also appears. The fuel level is displayed with a slight delay to prevent the indicator from constantly moving while riding. The fuel level display is not updated while the side stand is folded out or the emergency off switch is switched off. Once the side stand is folded up and the emergency OFF switch is switched on, the fuel level display is next updated after 2 minutes. If the dash does not receive a signal from the fuel level sensor, all fuel level display bars will flash.

7.20 Favourites display

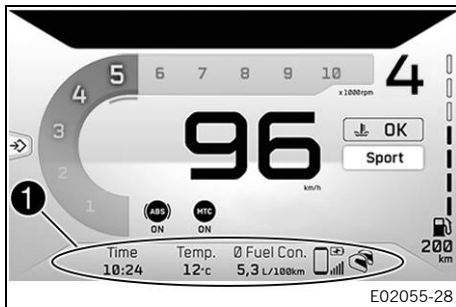

Up to four items of information are shown on the **Favourites** indicator. The **Favourites** indicator can be freely configured in the **Favourites** menu.

7.21 Navigation display (optional)

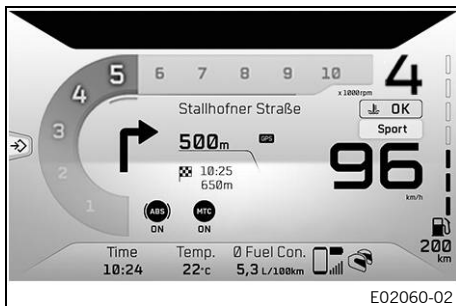

The **Navigation** indicator appears when the navigation function is active. The **Navigation** indicator shows the direction arrow, the distance to the next waypoint, the road name, the arrival time as well as the distance to the destination.

7.22 Call display

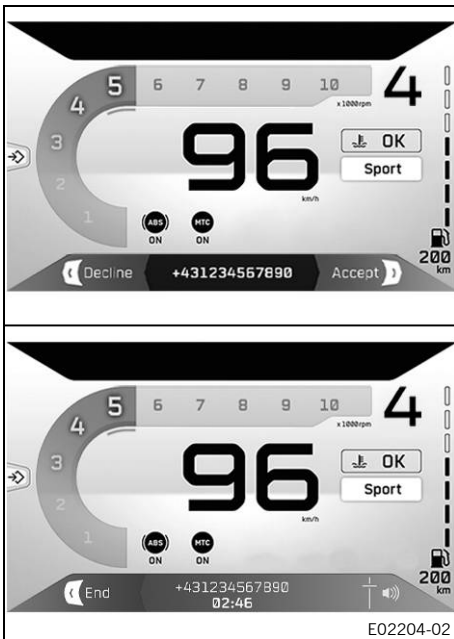

Warning

Danger of accidents Headphone volume which is too high distracts attention from traffic activity.

- Always select headphone volume which is low enough for you to still clearly hear acoustic signals.

The **Call** indicator appears for incoming or active calls. Press the **RIGHT** button to accept an incoming call. Press the **LEFT** button to reject an incoming call. Press the **UP** button to increase the audio volume. Press the **DOWN** button to reduce the audio volume.



Info

It is not possible to change the audio volume using the combination switch with every cellphone. The call duration and contact are displayed. Depending on the cellphone settings, the contact is shown by name. You cannot navigate in the menu during an active phone conversation.

7.23 Menu

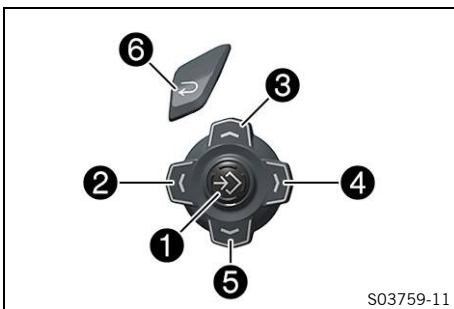

Info

Press the **SET** button **1** in the start screen to open the menu.

Use the **LEFT** key **2**, the **UP** key **3**, the **RIGHT** key **4** and the **DOWN** key **5** to navigate the menu.

Press the **BACK** button **6** to close the current menu or the menu overview.

7.23.1 KTM MY RIDE



Condition

- The motorcycle is stationary.
- **Bluetooth®** function is activated.
- Press the **SET** button or **RIGHT** button when the menu is closed.
- Press the **UP** button or **DOWN** button until **KTM MY RIDE** is marked. Press the **SET** or **RIGHT** button to open the menu.

A suitable cellphone or headset can be paired with the vehicle and the headset type set via **Bluetooth®** in the **KTM MY RIDE** menu.



Info

Not every cellphone and headset is suitable for pairing with the vehicle.

7.23.2 Phone



Condition

- The motorcycle is stationary.
 - **Bluetooth®** function is activated.
 - The **Bluetooth®** function should also be activated in the device to be paired.
- Press the **SET** button or **RIGHT** button when the menu is closed.
 - Press the **UP** button or **DOWN** button until **KTM MY RIDE** is marked. Press the **SET** or **RIGHT** button to open the menu.
 - Press the **UP** button or **DOWN** button until **Phone** is marked. Press the **SET** button to open the menu.

Info

Only one cellphone can be paired with the vehicle.

- Press the **UP** or **DOWN** button until **Pairing** is marked. Press the **SET** button to open the submenu.
- The vehicle starts searching for a suitable cellphone. If the search was successful, the name of the cellphone is displayed in the **New Pairing** submenu. Press the **SET** button to start the pairing.

Info

The cellphone must be visible via **Bluetooth®** for the vehicle to find the cellphone.

- A message appears on the dash indicating that the vehicle is now ready for pairing. The pairing is completed successfully by confirming the **Passkey** on the cellphone and on the dash.

Info

Press the **UP** or **DOWN** button until **Delete Pairing** is marked. The paired device can be deleted by pressing the **SET** button.
Not every cellphone is suitable for pairing with the vehicle.

- Move the previously paired device into the range of the vehicle while the **Bluetooth®** function is active.
 - ✓ The device is automatically connected with the vehicle.
 - ✗ If the device is not automatically connected with the vehicle after approx. 30 seconds:
 - Switch on the vehicle again or repeat the **New Pairing** procedure.

A suitable cellphone can be paired with the vehicle in the **Phone** submenu.

7.23.3 Rider's Headset

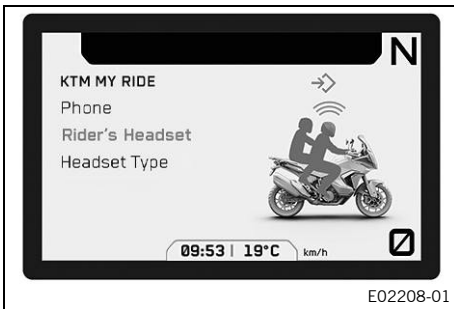

Condition

- The motorcycle is stationary.
 - **Bluetooth®** function is activated.
 - The **Bluetooth®** function should also be activated in the device to be paired.
- Press the **SET** button or **RIGHT** button when the menu is closed.
 - Press the **UP** button or **DOWN** button until **KTM MY RIDE** is marked. Press the **SET** or **RIGHT** button to open the menu.
 - Press the **UP** button or **DOWN** button until **Rider's Headset** is marked. Press the **SET** button to open the menu.
 - Press the **UP** or **DOWN** button until **New Pairing** is marked. Press the **SET** button to open the submenu.
 - The vehicle starts searching for a suitable headset. If the search was successful, the name of the rider's headset is displayed in the **New Pairing** submenu. Press the **SET** button to start the pairing.

i Info

The headset must be in pairing mode for the vehicle to find the headset. Follow the instructions in the headset owner's manual.

Press the **UP** or **DOWN** button until **Delete Pairing** is marked. The paired device can be deleted by pressing the **SET** button.

Not every headset is suitable for pairing with the vehicle.

- Move the previously paired device into the range of the vehicle while the **Bluetooth®** function is active.
- ✓ The device is automatically connected with the vehicle.
- ✗ If the device is not automatically connected with the vehicle after approx. 30 seconds:
 - Switch on the vehicle again or repeat the **New Pairing** procedure.

A suitable rider headset can be paired with the vehicle in the **Rider's Headset** submenu.

7.23.4 Headset Type

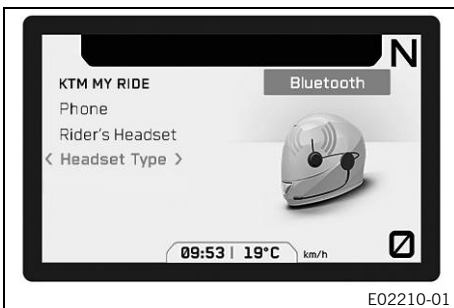

Condition

- The motorcycle is stationary.
- Press the **SET** button or **RIGHT** button when the menu is closed.
 - Press the **UP** button or **DOWN** button until **KTM MY RIDE** is marked. Press the **SET** or **RIGHT** button to open the menu.
 - Press the **UP** button or **DOWN** button until **Headset Type** is marked. Press the **RIGHT** or **LEFT** button to change the rider headset type.

The connection type of the rider headset can be selected in the **Headset Type** submenu.

The headset is connected directly to the smartphone by a cable in **Corded** mode.

The headset is connected to the vehicle wirelessly via **Bluetooth®** in the **Bluetooth** mode.



Info

The **Rider's Headset** menu item is only available in **Headset TypeBluetooth**.

7.23.5 Navigation (optional)

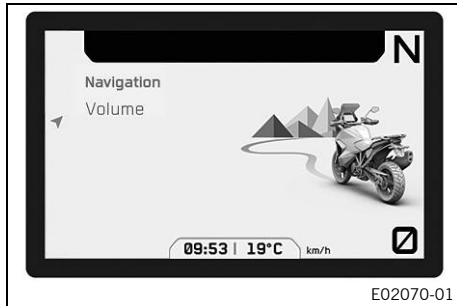

Condition

- **Bluetooth®** function is activated.
- The **KTM MY RIDE Navigation** app (optional) is installed and opened on a suitable cellphone (**Android®** devices from version 6.0 and higher, iOS devices from version 10 and higher).
- The combination instrument is connected to a suitable cellphone.
- The GPS function is activated on the connected cellphone.
- For voice navigation: The dash is connected to a suitable headset or the **Headset TypeCorded** is selected and an appropriate language package has been downloaded in the **KTM MY RIDE** app.
 - Press the **SET** button or **RIGHT** button when the menu is closed.
 - Press the **UP** button or **DOWN** button until **Navigation** is marked. Press the **SET** or the **RIGHT** button to open the menu.

The volume of the voice navigation can be configured in **Navigation**.



Info

The **Audio** function can be used with the navigation function at the same time. When the navigation function is switched on and the device is connected, the **GPS** symbol appears on the dash display.

7.23.6 Navigation volume (optional)



Condition

- **Bluetooth®** function is activated.
- The **KTM MY RIDE Navigation** app (optional) is installed and opened on a suitable cellphone (**Android®** devices from version 6.0 and higher, iOS devices from version 10 and higher).
- The combination instrument is connected to a suitable cellphone.
- The GPS function is activated on the connected cellphone.
- For voice navigation: The dash is connected to a suitable headset or the **Headset TypeCorded** is selected and an appropriate language package has been downloaded in the **KTM MY RIDE** app.
 - Press the **UP** button or **DOWN** button until **Navigation** is marked. Press the **SET** or the **RIGHT** button to open the menu.



Warning

Danger of accidents Headphone volume which is too high distracts attention from traffic activity.

- Always select headphone volume which is low enough for you to still clearly hear acoustic signals.

- Press the **UP** or **DOWN** button until **Volume** is marked.



Info

Press the **RIGHT** button to increase the audio volume.
Press the **LEFT** button to reduce the audio volume.

The volume of the voice navigation can be set in the **Volume** sub-menu.

7.23.7 Audio



E02064-01

Condition

- **Bluetooth**® function is activated.
- The combination instrument is connected to a suitable cell-phone.
- The dash is connected to a suitable headset or the **Headset TypeCorded** is selected.
- Press the **SET** button or **RIGHT** button when the menu is closed.



Warning

Danger of accidents Headphone volume which is too high distracts attention from traffic activity.

- Always select headphone volume which is low enough for you to still clearly hear acoustic signals.

- Press the **UP** button or **DOWN** button until **Audio** is marked.
Press the **SET** or the **RIGHT** button to open the menu.

You can control the volume and track selection in **Audio**.

7.23.8 Audio



E02201-01

Condition

- **Bluetooth**® function is activated.
- The combination instrument is connected to a suitable cell-phone.
- The dash is connected to a suitable headset or the **Headset TypeCorded** is selected.



Warning

Danger of accidents Headphone volume which is too high distracts attention from traffic activity.

- Always select headphone volume which is low enough for you to still clearly hear acoustic signals.

- Press the **UP** button or **DOWN** button until **Audio** is marked.
Press the **SET** or the **RIGHT** button to open the menu.
- Press the **UP** button to increase the audio volume.

- Press the **DOWN** button to reduce the audio volume.
- Press the **RIGHT** button change to the next audio track.
- Pressing the **LEFT** button changes to the previous audio track or plays the current audio track from the start, depending on the cellphone model.
- Press the **SET** button to play or pause the audio track.



Tip

With some cellphones, the audio player needs to be started before playback is possible. The **Audio** function can be added to **C1** or **C2** for easier operation.

7.23.9 Bike Info



E02073-01

- Press the **SET** button or **RIGHT** button when the menu is closed.
- Press the **UP** button or **DOWN** button until **Bike Info** is marked. Press the **SET** or **RIGHT** button to open the menu.

General information and warnings that may be available **Bike Info** can be called up in.

7.23.10 Bike Info

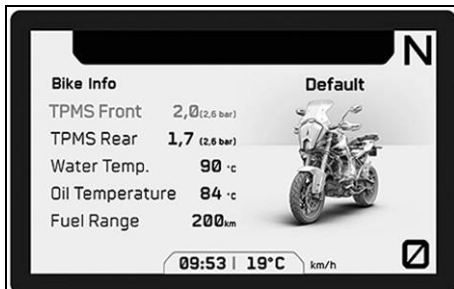

- Press the **SET** button when the menu is closed.
- Press the **UP** or **DOWN** button until **Info** is marked. Press the **SET** button to open the menu.
- Press the **UP** or **DOWN** button until **Bike Info** is marked. Press the **SET** or **RIGHT** button to open the submenu.

TPMS Front (optional) shows the current tire air pressure of the front tire.

TPMS Rear (optional) shows the current tire air pressure of the rear tire.

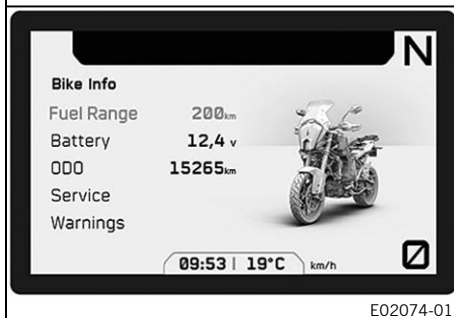

E02074-01



Info

The set reference value is displayed on the right of the current tire air pressure in parentheses.

The tire pressure monitoring system mode can be set in the menu **TPMS Mode** (optional).

Water Temp. displays the coolant temperature.

Oil Temperature displays the engine oil temperature.

Fuel Range indicates the possible fuel range you can cover with the fuel reserve.

Battery indicates the battery voltage.

ODO displays the total distance covered.

Service displays when the next service is due.

Warnings displays warnings that have occurred until they are no longer active.

7.23.11 Trip

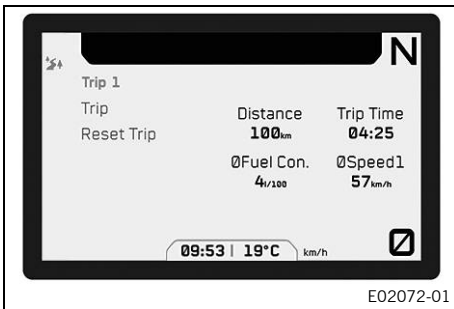

- Press the **SET** button or **RIGHT** button when the menu is closed.
- Press the **UP** button or **DOWN** button until **Trip** is marked. Press the **SET** or the **RIGHT** button to open the menu.

General information on the distance traveled, trip time, average fuel consumption and average speed can be accessed in **Trip**. The trips can be switched and reset.

7.23.12 Trip 1

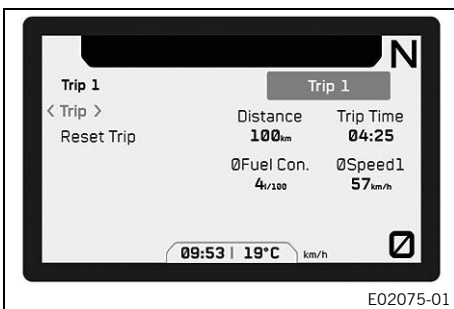

- Press the **SET** button or **RIGHT** button when the menu is closed.
- Press the **UP** button or **DOWN** button until **Trip** is marked. Press the **SET** or the **RIGHT** button to open the menu.
- Press the **UP** button or **DOWN** button until **Trip** is marked. Press the **RIGHT** or **LEFT** button until **Trip 1** is selected.

Distance displays the distance since the last reset, such as between two refueling stops. **Distance** is running and counts up to **9999**.

Ø Fuel Con. indicates the average fuel consumption based on **Distance**.

ØSpeed1 indicates the average speed based on **Distance** and **Trip Time**.

Trip Time displays the trip time on the basis of **Distance** and runs as soon as the dash receives a speed signal.

i Info

All data for the currently selected trip odometer is reset with **Reset Trip**.

7.23.13 Trip 2



- Press the **SET** button or **RIGHT** button when the menu is closed.
- Press the **UP** button or **DOWN** button until **Trip** is marked. Press the **SET** or the **RIGHT** button to open the menu.
- Press the **UP** button or **DOWN** button until **Trip** is marked. Press the **RIGHT** or **LEFT** button until **Trip 2** is selected.

Distance displays the distance since the last reset, such as between two refueling stops. **Distance** is running and counts up to **9999**.

Ø Fuel Con. indicates the average fuel consumption based on **Distance**.

ØSpeed2 indicates the average speed based on **Distance** and **Trip Time**.

Trip Time displays the trip time on the basis of **Distance** and runs as soon as the dash receives a speed signal.

i Info

All data for the currently selected trip odometer is reset with **Reset Trip**.

7.23.14 Motorcycle

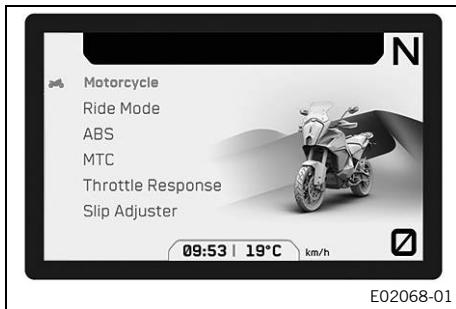

E02068-01

- Press the **SET** button or **RIGHT** button when the menu is closed.
- Press the **UP** button or **DOWN** button until **Motorcycle** is marked. Press the **SET** or the **RIGHT** button to open the menu.

The ride mode, ABS mode, and traction control of the vehicle can be configured in **Motorcycle**.

When the **Ride Mode Rally** (optional) is activated, the characteristics of the throttle response and slip on the rear wheel can also be configured.

7.23.15 Ride Mode

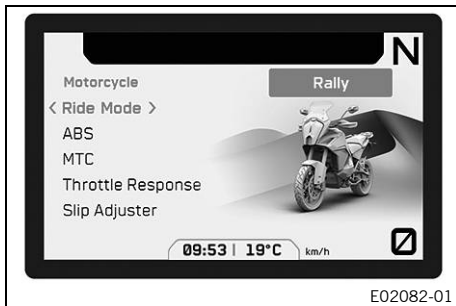

E02082-01

Condition

- Start button/emergency OFF switch on (middle position) – This position is required for operation; the ignition circuit is closed. (📖 p. 20)
- Cruise control function deactivated.
- Press the **SET** button or **RIGHT** button when the menu is closed.
- Press the **UP** button or **DOWN** button until **Motorcycle** is marked. Press the **SET** or the **RIGHT** button to open the menu.



Warning

Danger of accidents An incorrectly selected riding mode makes control of the vehicle considerably more difficult.

The riding modes are each only suitable for certain conditions.

- Always select a riding mode that suits the surface on which you are riding, the weather and the riding situation.

- Press the **UP** button or **DOWN** button until **Ride Mode** is marked.
- Press the **RIGHT** or **LEFT** button to select the **Ride Mode** to change the settings of the engine and motorcycle traction control that are coordinated with each other.

Guideline

Only use ride modes **SPORT**, **STREET** and **RAIN** on asphalt.

Only use ride modes **OFFROAD** and **RALLY** (optional) on unpaved roads.

- ✓ **SPORT** - Homologated performance with very direct response; the motorcycle traction control allows greater slip on the rear wheel.
- ✓ **STREET** - Homologated performance with balanced response; the motorcycle traction control allows normal slip on the rear wheel.
- ✓ **RAIN** - Reduced homologated performance with soft response for improved rideability on surfaces with low road grip; the motorcycle traction control allows very little slip on the rear wheel.

- ✓ **OFFROAD**- Reduced homologated performance for better rideability on unpaved roads; the motorcycle traction control allows high slip on the rear wheel.
- ✓ **RALLY** (optional) - setting with homologated performance and extremely direct response. The motorcycle traction control and the characteristics of the throttle response can be individually set.



Info

Do not open the throttle during the selection.

7.23.16 MTC

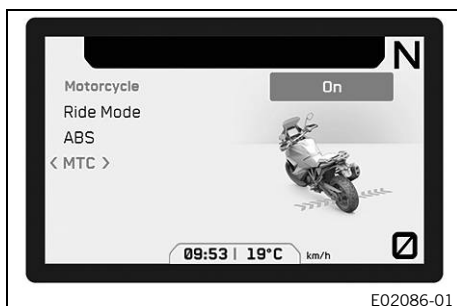

E02086-01

Condition

- Cruise control function deactivated.
- Press the **SET** button or **RIGHT** button when the menu is closed.
- Press the **UP** button or **DOWN** button until **Motorcycle** is marked. Press the **SET** or the **RIGHT** button to open the menu.
- Press the **UP** button or **DOWN** button until **MTC** is marked.
- Press the **RIGHT** or **LEFT** button to switch the **MTC** on or off.



Info

Do not open the throttle when switching on or off. Press the **RIGHT** or **LEFT** button briefly when activating the motorcycle traction control. Hold down the **RIGHT** or **LEFT** button when switching off the motorcycle traction control. After the ignition is switched on, motorcycle traction control is enabled again.

7.23.17 MTC+MSR (optional)

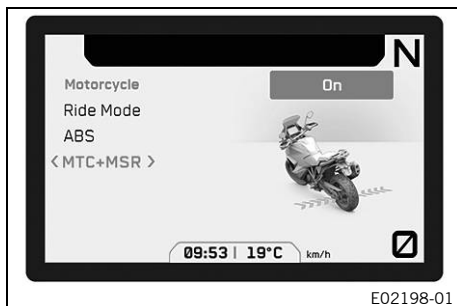

E02198-01

Condition

- Model with **MTC+MSR** (optional)
- Cruise control function deactivated.
- Press the **SET** button or **RIGHT** button when the menu is closed.
- Press the **UP** button or **DOWN** button until **Motorcycle** is marked. Press the **SET** or the **RIGHT** button to open the menu.
- Press the **UP** button or **DOWN** button until **MTC+MSR** is marked.
- Press the **RIGHT** or **LEFT** button to switch the **MTC+MSR** on or off.

i Info

Do not open the throttle when switching on or off. Press the **RIGHT** or **LEFT** button briefly when activating the motorcycle traction control and the motor slip regulation. Hold down the **RIGHT** or **LEFT** button when switching off the motorcycle traction control and motor slip regulation. When ABS mode **Offroad** is active, the **MSR** is not active. After the ignition is switched on, the motorcycle traction control and engine traction torque control are enabled again.

7.23.18 ABS

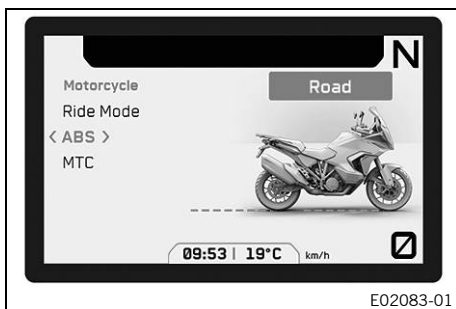

- Press the **SET** button or **RIGHT** button when the menu is closed.
- Press the **UP** button or **DOWN** button until **Motorcycle** is marked. Press the **SET** or the **RIGHT** button to open the menu.

! Warning

Danger of accidents An incorrectly selected ABS mode makes control of the vehicle considerably more difficult.

The ABS modes are each only suitable for certain conditions.

- Always select an ABS mode that is compatible with the surface of the ground.

- Press the **UP** button or **DOWN** button until **ABS** is marked.
- Press the **RIGHT** or **LEFT** button to select between ABS modes.

Guideline

Only use Road ABS mode on asphalt.
Only use Offroad ABS mode on unpaved roads.

i Info

The ABS mode can be switched during the journey. Do not open the throttle during the selection. If ABS mode **Road** is enabled, ABS controls both wheels. If the ABS mode **Offroad** is enabled, ABS controls later and only on the front wheel. The rear wheel is not controlled by ABS and may lock during braking maneuvers. The curve dependent control and rollover protection are only active in ABS mode **Road**.

7.23.19 Throttle Response (optional)



Condition

- The ride mode **RALLY** (optional) is activated.
- Press the **SET** button or **RIGHT** button when the menu is closed.
- Press the **UP** button or **DOWN** button until **Motorcycle** is marked. Press the **SET** or the **RIGHT** button to open the menu.



Warning

Danger of accidents An incorrectly selected riding mode makes control of the vehicle considerably more difficult.

The riding modes are each only suitable for certain conditions.

- Always select a riding mode that suits the surface on which you are riding, the weather and the riding situation.

- Press the **UP** button or **DOWN** button until **Throttle Response** is marked.
- Press **RIGHT** or **LEFT Throttle Response** button to select Mode.
 - ✓ **STREET**- Balanced response.
 - ✓ **SPORT**- Very direct response.
 - ✓ **RALLY**- Extremely direct response.
 - ✓ **OFFROAD**- Gentle response.



Info

Do not open the throttle when setting the throttle response.

7.23.20 Slip Adjuster (optional)

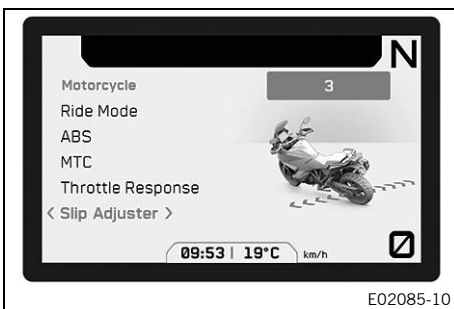

Condition

- The ride mode **RALLY** (optional) is activated.
- **MTC** is activated.
- Press the **SET** button or **RIGHT** button when the menu is closed.
- Press the **UP** button or **DOWN** button until **Motorcycle** is marked. Press the **SET** or the **RIGHT** button to open the menu.



Warning

Danger of accidents An incorrectly selected riding mode makes control of the vehicle considerably more difficult.

The riding modes are each only suitable for certain conditions.

- Always select a riding mode that suits the surface on which you are riding, the weather and the riding situation.

- Press the **UP** button or **DOWN** button until **Slip Adjuster** is marked.

- Press the **RIGHT** or **LEFT** button to set the maximum permitted slip of the motorcycle traction control.



Info

Do not open the throttle during the selection.

The spin adjuster is a motorcycle traction control function. The slip adjustment allows the motorcycle traction control to be tuned through nine levels to the desired characteristic map. Level 1 allows the maximum slip on the rear wheel, and level 9 the minimum.

If the cruise control function is deactivated, the buttons **+RES** and **-SET** on the main display or in the **Slip Adjuster** menu can be used to adjust the **Slip Adjuster**.



Info

The spin adjuster is only available in **RALLY** ride mode (optional).

The spin adjuster is only available when motorcycle traction control is activated.

7.23.21 Settings

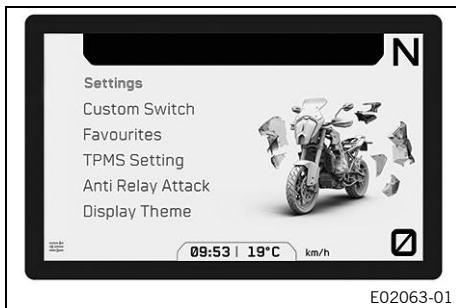

E02063-01

Condition

- The motorcycle is stationary.
- Press the **SET** button or **RIGHT** button when the menu is closed.
- Press the **UP** button or **DOWN** button until **Settings** is marked. Press the **SET** or the **RIGHT** button to open the menu.

Favourites, quick selections and the dash display can be configured in **Settings**.

Settings can be made for units or various values. Several functions can be enabled or disabled

7.23.22 Custom Switch

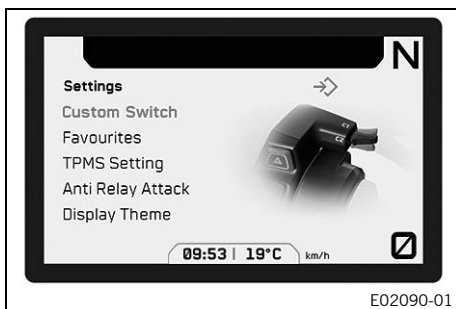

E02090-01

Condition

- The motorcycle is stationary.
- Press the **SET** button or **RIGHT** button when the menu is closed.
- Press the **UP** or **DOWN** button until **Settings** is marked. Press the **SET** or the **RIGHT** button to open the menu.
- Press the **UP** or **DOWN** button until **Custom Switch** is marked.
- Press the **SET** button to open the menu.

In **Custom Switch**, the quick access buttons can be freely configured.

7.23.23 Taste C1 und C2

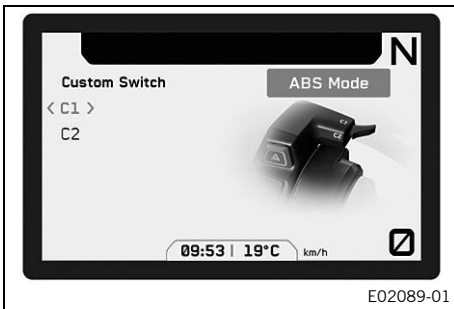

Condition

- The motorcycle is stationary.
- Press the **SET** button or **RIGHT** button when the menu is closed.
- Press the **UP** or **DOWN** button until **Settings** is marked. Press the **SET** or the **RIGHT** button to open the menu.
- Press the **UP** or **DOWN** button until **Custom Switch** is marked.
- Press the **SET** button to open the menu.
- Press **UP** or **DOWN** button until **C1** or **C2** is marked.
- Press the **RIGHT** or **LEFT** button to select the desired function.



Info

In the menu **Custom Switch**, the C1 and C2 buttons can be assigned different quick accesses, e.g.

ABS Mode and **Ride Mode**.

The **C1** switch is used to access the quick access set in **C1**.

The **C2** switch is used to access the quick access set in **C2**.

7.23.24 Favourites

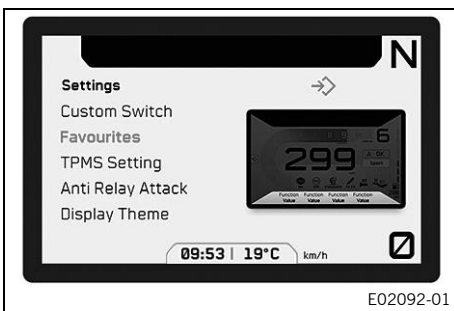

Condition

- The motorcycle is stationary.
- Press the **SET** button or **RIGHT** button when the menu is closed.
- Press the **UP** or **DOWN** button until **Settings** is marked. Press the **SET** or the **RIGHT** button to open the menu.
- Press the **UP** or **DOWN** button until **Favourites** is marked.
- Press the **SET** button to open the menu.

In **Favourites**, up to four items of information, e.g. **Oil Temperature** and **Battery** can be selected, which are displayed on the **Favourites** indicator on the display.

7.23.25 Favourites indicator 1-4

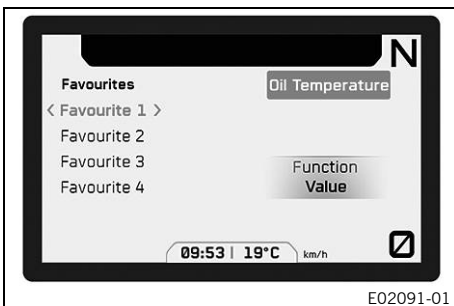

Condition

- The motorcycle is stationary.
- Press the **SET** button or **RIGHT** button when the menu is closed.
- Press the **UP** or **DOWN** button until **Settings** is marked. Press the **SET** or the **RIGHT** button to open the menu.
- Press the **UP** or **DOWN** button until **Favourites** is marked.
- Press the **SET** button to open the menu.
- Press the **UP** or **DOWN** button until **Favourite 1**, **Favourite 2**, **Favourite 3** or **Favourite 4** is marked.
- Press the **RIGHT** or **LEFT** button to select the desired information.

7.23.26 TPMS Setting

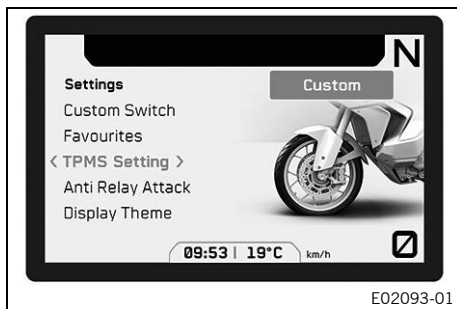

Condition

- The motorcycle is stationary.
- Model with **TPMS**.
 - Press the **SET** button or **RIGHT** button when the menu is closed.
 - Press the **UP** or **DOWN** button until **Settings** is marked. Press the **SET** or the **RIGHT** button to open the menu.
 - Press the **UP** or **DOWN** button until **TPMS Setting** is marked.
 - Press the **RIGHT** or **LEFT** button to select the desired **TPMS** mode.

Three different **TPMS** modes can be selected in the **TPMS Setting** menu.

The **Default** mode corresponds to the preset basic setting of the tire air pressure monitor recommended by KTM.

The **Custom** mode corresponds to the custom setting of the tire air pressure monitor.

i Info

Before **TPMS** mode **Custom** is selected, the desired air pressure of the tires must be adjusted.

When **TPMS** mode **Custom** is selected, the next received value of the **TPMS** sensors is saved as a new reference value.

It may take some time for the **TPMS** sensors to send a value and for the new reference value to be saved.

The reference value can be between 1 bar and 5 bar (between 14.5 psi and 72.5 psi).

The stored reference value is displayed in the **Bike Info** menu.

If the value currently measured by the tire air pressure sensors is more than 50 % above or 20 % below the stored reference value, a warning appears on the combination instrument display.

In **Warnings Off** mode, the warnings from the tire air pressure monitor are deactivated. The tire air pressure is still measured by the tire air pressure sensors, but warnings no longer appear on the combination instrument display.

i Info

KTM recommends **Default** mode.

A second wheel set can be programmed via the KTM diagnostics tool. Your authorized KTM workshop will be glad to help.

7.23.27 Anti Relay Attack

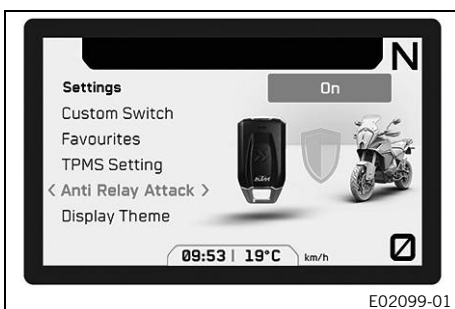
**Condition**

- The motorcycle is stationary.
- Press the **SET** button or **RIGHT** button when the menu is closed.
- Press the **UP** or **DOWN** button until **Settings** is marked. Press the **SET** or the **RIGHT** button to open the menu.
- Press the **UP** or **DOWN** button until **Anti Relay Attack** is marked.
- Use the **RIGHT** or **LEFT** button to switch **Anti Relay Attack** (📖 p. 22) on or off.

7.23.28 Display Theme

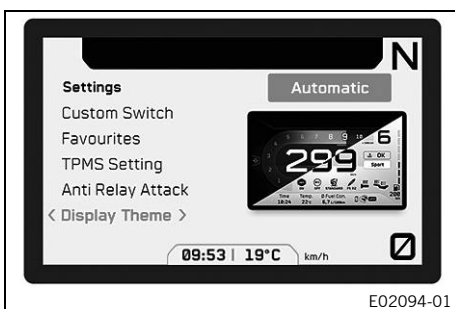
**Condition**

- The motorcycle is stationary.
- Press the **SET** button or **RIGHT** button when the menu is closed.
- Press the **UP** or **DOWN** button until **Settings** is marked. Press the **SET** or the **RIGHT** button to open the menu.
- Press the **UP** or **DOWN** button until **Display Theme** is marked.
- Press the **RIGHT** or **LEFT** button to select the desired **Display Theme** mode.

In **Automatic** mode, the day or night mode is automatically changed by the ambient light sensor integrated into the display. In **Night** mode, the indicator remains in night mode.

7.23.29 Button Illumination

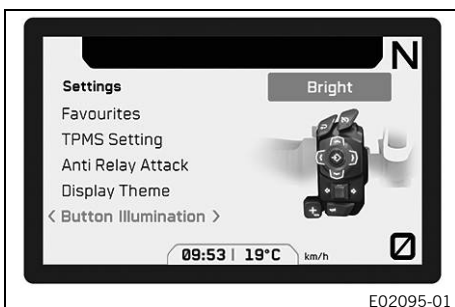
**Condition**

- The motorcycle is stationary.
- Press the **SET** button or **RIGHT** button when the menu is closed.
- Press the **UP** or **DOWN** button until **Settings** is marked. Press the **SET** or the **RIGHT** button to open the menu.
- Press the **UP** or **DOWN** button until **Button Illumination** is marked.
- Press the **RIGHT** or **LEFT** button to select the button illumination level or switch off the button lighting.

7.23.30 DRL

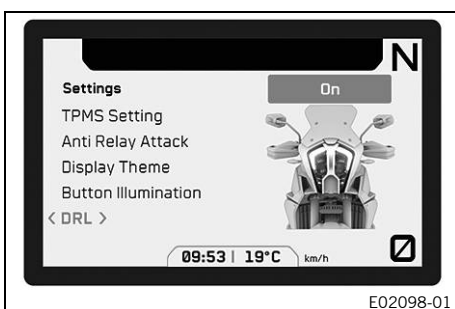
**Condition**

- The motorcycle is stationary.
- Press the **SET** button or **RIGHT** button when the menu is closed.
- Press the **UP** or **DOWN** button until **Settings** is marked. Press the **SET** or the **RIGHT** button to open the menu.
- Press the **UP** or **DOWN** button until **DRL** is marked.
- Press the **RIGHT** or **LEFT** button to switch the daytime running light on or off.

**Info**

After the ignition is switched back on, the daytime running light is reactivated.

7.23.31 Bluetooth

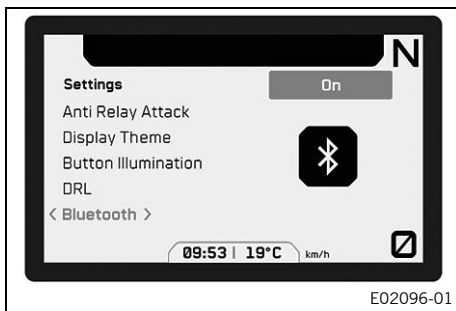

Condition

- The motorcycle is stationary.
- Press the **SET** button or **RIGHT** button when the menu is closed.
- Press the **UP** or **DOWN** button until **Settings** is marked. Press the **SET** or the **RIGHT** button to open the menu.
- Press the **UP** or **DOWN** button until **Bluetooth** is marked.
- Press the **RIGHT** or **LEFT** button to switch the **Bluetooth** on or off.

The function **Bluetooth**[®] must be activated to pair a suitable cell-phone or headset with the vehicle.
Not every phone or headset is suitable for pairing with the vehicle.

7.23.32 Quickshifter + (optional)

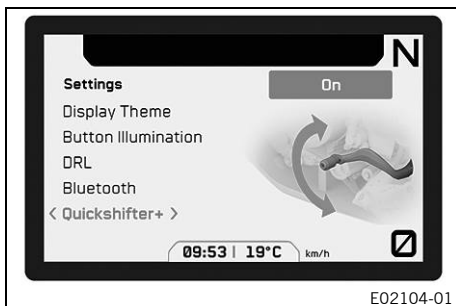

Condition

- The motorcycle is stationary.
- Press the **SET** button or **RIGHT** button when the menu is closed.
- Press the **UP** or **DOWN** button until **Settings** is marked. Press the **SET** or the **RIGHT** button to open the menu.
- Press the **UP** or **DOWN** button until **Quickshifter +** is marked.
- Press the **RIGHT** or **LEFT** button to switch the **Quickshifter +** on or off.

7.23.33 Hill Hold Control (optional)

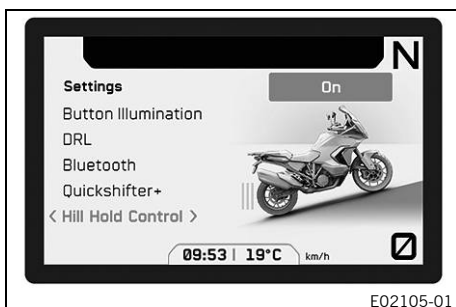

Condition

- The motorcycle is stationary.
- Press the **SET** button or **RIGHT** button when the menu is closed.
- Press the **UP** or **DOWN** button until **Settings** is marked. Press the **SET** or the **RIGHT** button to open the menu.
- Press the **UP** or **DOWN** button until **Hill Hold Control** is marked.
- Press the **RIGHT** or **LEFT** button to switch the hill hold control on or off.

7.23.34 Shift Light

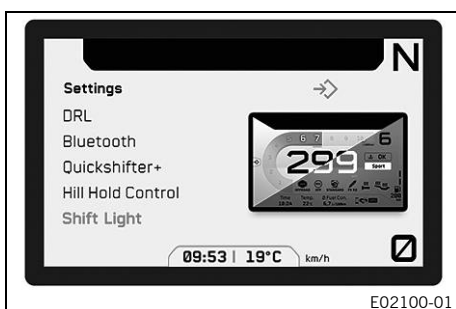

Condition

- The motorcycle is stationary.
- **ODO** > 1,000 km (621 mi).
- Press the **SET** button or **RIGHT** button when the menu is closed.
- Press the **UP** or **DOWN** button until **Settings** is marked. Press the **SET** or the **RIGHT** button to open the menu.
- Press the **UP** or **DOWN** button until **Shift Light** is marked.
- Press the **SET** button to open the menu.

In **Shift Light**, the rpm for the shift light can be set.

7.23.35 Shift Light State

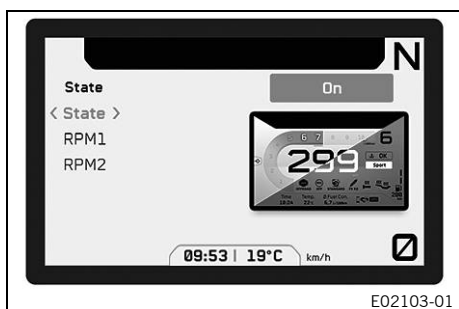

Condition

- The motorcycle is stationary.
- Press the **SET** button or **RIGHT** button when the menu is closed.
- Press the **UP** or **DOWN** button until **Settings** is marked. Press the **SET** or the **RIGHT** button to open the menu.
- Press the **UP** or **DOWN** button until **Shift Light** is marked.
- Press the **SET** button to open the menu.
- Press the **UP** or **DOWN** button until **State** is marked.
- Use the **RIGHT** or **LEFT** button to switch the shift light on or off.

7.23.36 Shift Light RPM1

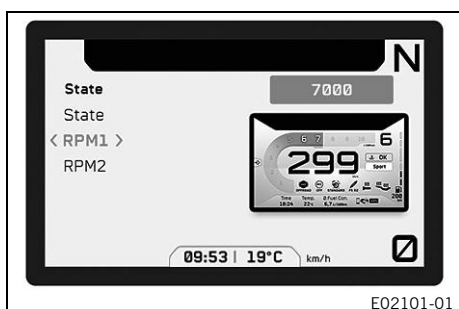

Condition

- The motorcycle is stationary.
- Press the **SET** button or **RIGHT** button when the menu is closed.
- Press the **UP** or **DOWN** button until **Settings** is marked. Press the **SET** or the **RIGHT** button to open the menu.
- Press the **UP** or **DOWN** button until **Shift Light** is marked.
- Press the **SET** button to open the menu.
- Press the **UP** or **DOWN** button until **RPM1** is marked.
- Press the **RIGHT** or **LEFT** button to set the value for **RPM1**.



Info

RPM1 can be set between 5,000 and 10,000 rpm in increments of 500 rpm.

RPM1 must not be larger than **RPM2**.

If the engine speed reaches the set value **RPM1**, the shift light flashes red.

7.23.37 Shift Light RPM2

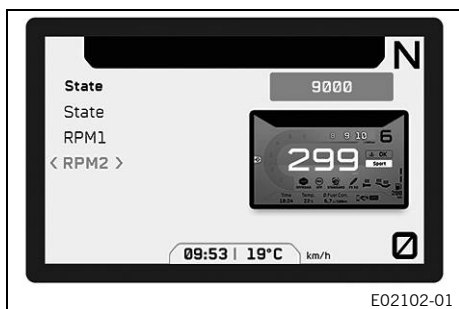

Condition

- The motorcycle is stationary.
- Press the **SET** button or **RIGHT** button when the menu is closed.
- Press the **UP** or **DOWN** button until **Settings** is marked. Press the **SET** or the **RIGHT** button to open the menu.
- Press the **UP** or **DOWN** button until **Shift Light** is marked.
- Press the **SET** button to open the menu.
- Press the **UP** or **DOWN** button until **RPM2** is marked.
- Press the **RIGHT** or **LEFT** button to set the value for **RPM2**.



Info

RPM2 can be set between 5,000 and 10,000 rpm in increments of 500 rpm.

RPM2 must not be smaller than **RPM1**.

When the engine speed reaches the set value **RPM2**, the entire display flashes red.

7.23.38 Clock & Date

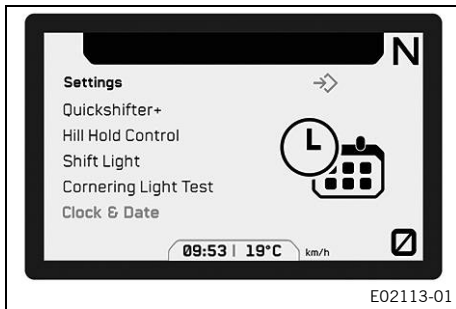

Condition

- The motorcycle is stationary.
- Press the **SET** button or **RIGHT** button when the menu is closed.
- Press the **UP** or **DOWN** button until **Settings** is marked. Press the **SET** or the **RIGHT** button to open the menu.
- Press the **UP** or **DOWN** button until **Clock & Date** is marked.
- Press the **SET** button to open the menu.

Set the time, date and display formats in **Clock & Date**.

7.23.39 Clock Format

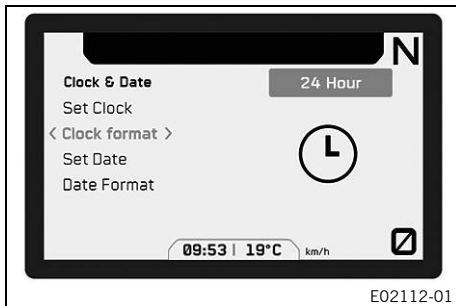

Condition

- The motorcycle is stationary.
- Press the **SET** button or **RIGHT** button when the menu is closed.
- Press the **UP** or **DOWN** button until **Settings** is marked. Press the **SET** or the **RIGHT** button to open the menu.
- Press the **UP** or **DOWN** button until **Clock & Date** is marked.
- Press the **SET** button to open the menu.
- Press the **UP** or **DOWN** button until **Clock Format** is marked.
- Press the **RIGHT** or **LEFT** button to set the time format.

7.23.40 Date Format

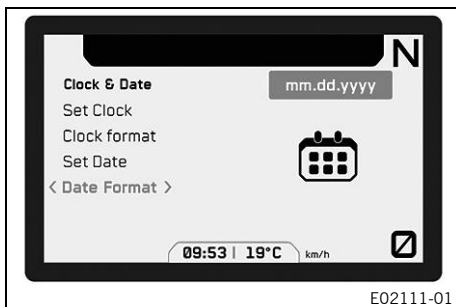

Condition

- The motorcycle is stationary.
- Press the **SET** button or **RIGHT** button when the menu is closed.
- Press the **UP** or **DOWN** button until **Settings** is marked. Press the **SET** or the **RIGHT** button to open the menu.
- Press the **UP** or **DOWN** button until **Clock & Date** is marked.
- Press the **SET** button to open the menu.
- Press the **UP** or **DOWN** button until **Date Format** is marked.
- Press the **RIGHT** or **LEFT** button to set the date format.

7.23.41 Units

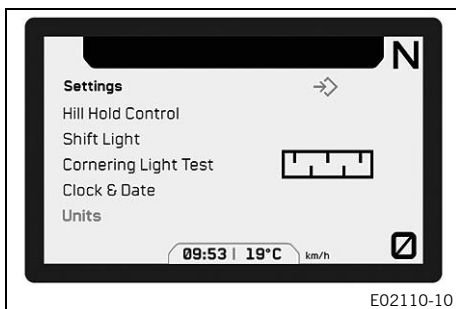

Condition

- The motorcycle is stationary.
- Press the **SET** button or **RIGHT** button when the menu is closed.
- Press the **UP** or **DOWN** button until **Settings** is marked. Press the **SET** or the **RIGHT** button to open the menu.
- Press the **UP** or **DOWN** button until **Units** is marked.
- Press the **SET** button to open the menu.

Units allows settings to be made for units or various values.

7.23.42 Units Distance

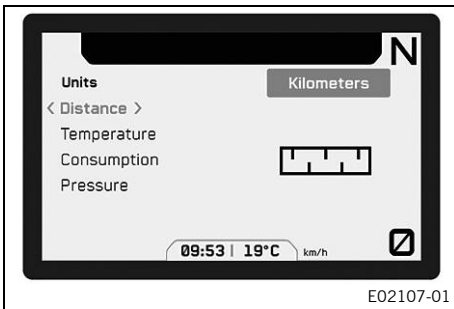

Condition

- The motorcycle is stationary.
- Press the **SET** button or **RIGHT** button when the menu is closed.
- Press the **UP** or **DOWN** button until **Settings** is marked. Press the **SET** or the **RIGHT** button to open the menu.
- Press the **UP** or **DOWN** button until **Units** is marked.
- Press the **SET** button to open the menu.
- Press the **UP** or **DOWN** button until **Distance** is marked.
- Press the **RIGHT** or **LEFT** button to set the distance unit.

7.23.43 Units Temperature

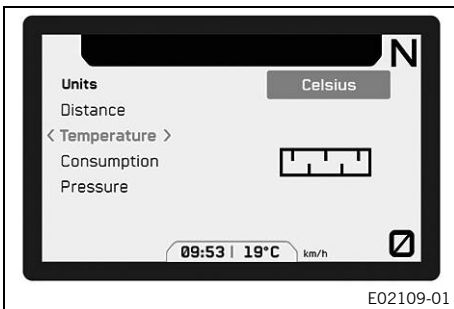

Condition

- The motorcycle is stationary.
- Press the **SET** button or **RIGHT** button when the menu is closed.
- Press the **UP** or **DOWN** button until **Settings** is marked. Press the **SET** or the **RIGHT** button to open the menu.
- Press the **UP** or **DOWN** button until **Units** is marked.
- Press the **SET** button to open the menu.
- Press the **UP** or **DOWN** button until **Temperature** is marked.
- Press the **RIGHT** or **LEFT** button to set the temperature unit.

7.23.44 Units Consumption

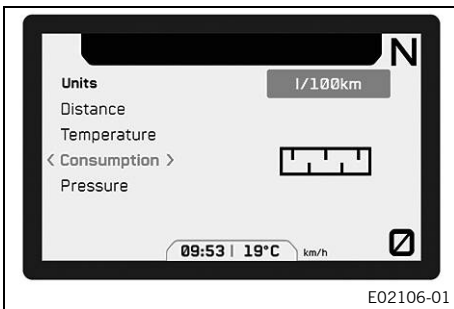

Condition

- The motorcycle is stationary.
- Press the **SET** button or **RIGHT** button when the menu is closed.
- Press the **UP** or **DOWN** button until **Settings** is marked. Press the **SET** or the **RIGHT** button to open the menu.
- Press the **UP** or **DOWN** button until **Units** is marked.
- Press the **SET** button to open the menu.
- Press the **UP** or **DOWN** button until **Consumption** is marked.
- Press the **RIGHT** or **LEFT** button to set the consumption unit.

7.23.45 Units Pressure

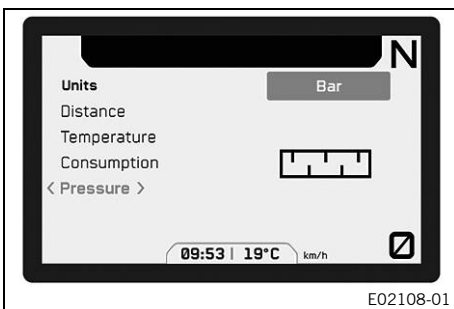

Condition

- The motorcycle is stationary.
- Press the **SET** button or **RIGHT** button when the menu is closed.
- Press the **UP** or **DOWN** button until **Settings** is marked. Press the **SET** or the **RIGHT** button to open the menu.
- Press the **UP** or **DOWN** button until **Units** is marked.
- Press the **SET** button to open the menu.
- Press the **UP** or **DOWN** button until **Pressure** is marked.
- Press the **RIGHT** or **LEFT** button to set the pressure unit.

7.23.46 Settings Heating

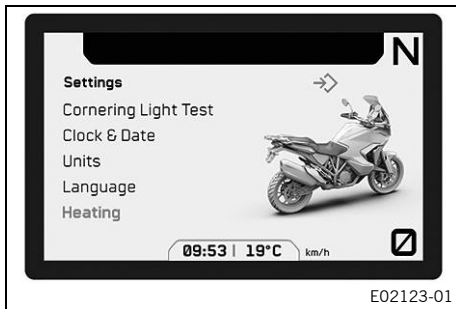

E02123-01

Condition

- The motorcycle is stationary.
- Press the **SET** button or **RIGHT** button when the menu is closed.
- Press the **UP** or **DOWN** button until **Settings** is marked. Press the **SET** or the **RIGHT** button to open the menu.
- Press the **UP** or **DOWN** button until **Heating** is marked.
- Press the **SET** button to open the menu.

The grip heater and the rider's and passenger seat heating can be activated or deactivated in **Settings Heating**.

7.23.47 Settings Heating Grips

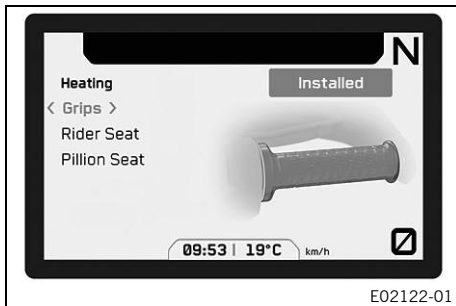

E02122-01

Condition

- The motorcycle is stationary.
- Press the **SET** button or **RIGHT** button when the menu is closed.
- Press the **UP** or **DOWN** button until **Settings** is marked. Press the **SET** or the **RIGHT** button to open the menu.
- Press the **UP** or **DOWN** button until **Heating** is marked.
- Press the **SET** button to open the menu.
- Press the **UP** or **DOWN** button until **Grips** is marked.
- Press the **RIGHT** or **LEFT** button to activate or deactivate the heated grips.

7.23.48 Settings Heating Rider Seat

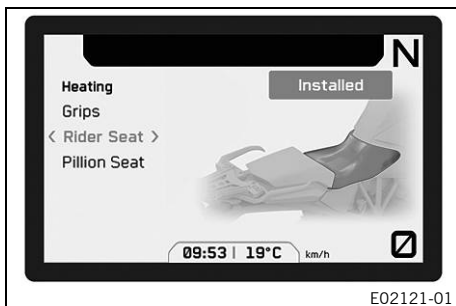

E02121-01

Condition

- Model with rider's seat heating.
- The motorcycle is stationary.
- Press the **SET** button or **RIGHT** button when the menu is closed.
- Press the **UP** or **DOWN** button until **Settings** is marked. Press the **SET** or the **RIGHT** button to open the menu.
- Press the **UP** or **DOWN** button until **Heating** is marked.
- Press the **SET** button to open the menu.
- Press the **UP** or **DOWN** button until **Rider Seat** is marked.
- Press the **RIGHT** or **LEFT** button to activate or deactivate the rider's seat heating.

7.23.49 Settings Heating Pillion Seat

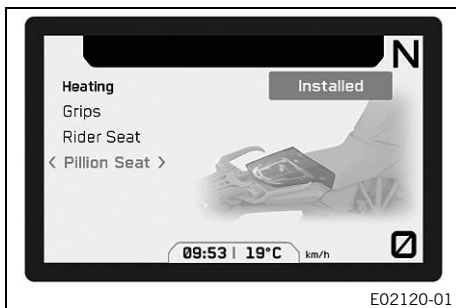

E02120-01

Condition

- Model with passenger seat heating.
- The motorcycle is stationary.
- Press the **SET** button or **RIGHT** button when the menu is closed.
- Press the **UP** or **DOWN** button until **Settings** is marked. Press the **SET** or the **RIGHT** button to open the menu.
- Press the **UP** or **DOWN** button until **Heating** is marked.
- Press the **SET** button to open the menu.
- Press the **UP** or **DOWN** button until **Pillion Seat** is marked.
- Press the **RIGHT** or **LEFT** button to activate or deactivate the passenger seat heating.

7.23.50 Extra Functions

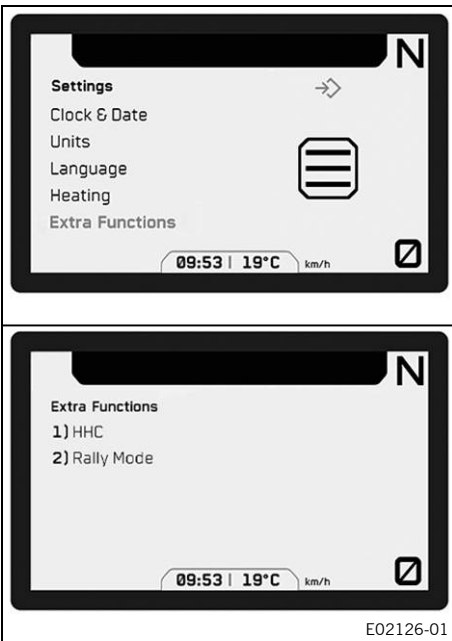

Condition

- The motorcycle is stationary.
- Motorcycle with optional supplementary function.
- Press the **SET** button or **RIGHT** button when the menu is closed.
- Press the **UP** or **DOWN** button until **Settings** is marked. Press the **SET** or the **RIGHT** button to open the menu.
- Press the **UP** or **DOWN** button until **Extra Functions** is marked.
- Press the **SET** button to open the submenu.



Info

The optional extra functions are listed.
The current **KTM PowerParts** and the available software for your vehicle can be found on the KTM website.

7.23.51 Setting the time and date

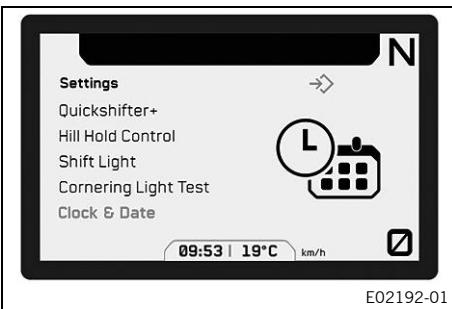

Condition

The motorcycle is stationary.

- Press the **SET** button or **RIGHT** button when the menu is closed.
- Press the **UP** button or **DOWN** button until **Settings** is marked.
- Press the **RIGHT** or **SET** button to open the menu.
- Press the **UP** button or **DOWN** button until **Clock & Date** is marked.
- Press the **SET** button to open the menu.

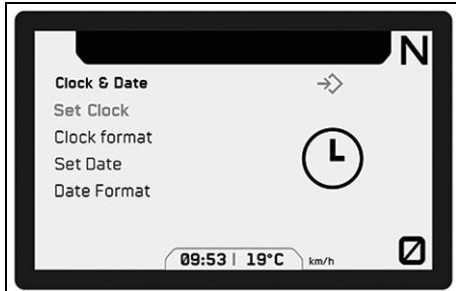

E02193-01

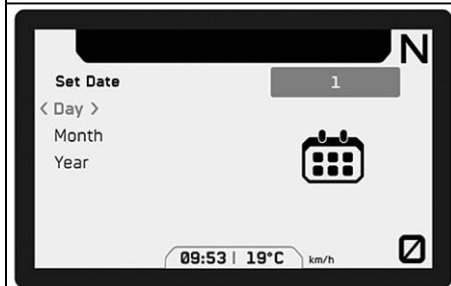
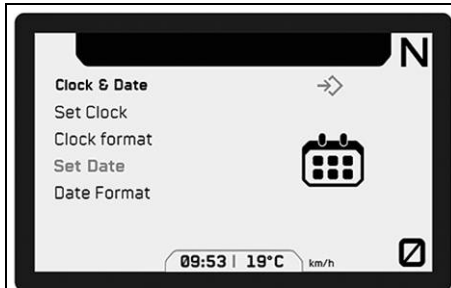
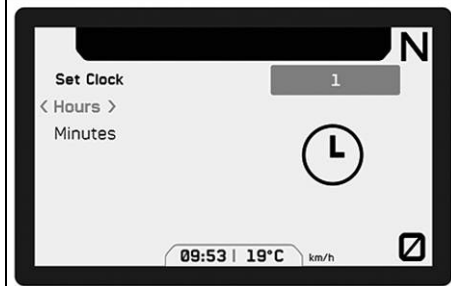

E02194-01

Setting the clock

- Press the **UP** or **DOWN** button until **Set Clock** is marked.
- Press the **SET** button to open the menu.
- Press the **UP** or **DOWN** button until **Hours** is marked.
- Press the **RIGHT** or **LEFT** button until the current hour is set.
- Press the **UP** or **DOWN** button until **Minutes** is marked.
- Press the **RIGHT** or **LEFT** button until the current minute is set.
- Press the **BACK** button to exit the menu.
- ✓ The time is stored.

Setting the date

- Press the **UP** or **DOWN** button until **Set Date** is marked.
- Press the **SET** button to open the menu.
- Press the **UP** or **DOWN** button until **Day** is marked.
- Press the **RIGHT** or **LEFT** button until the current day is set.
- Press the **UP** or **DOWN** button until **Month** is marked.
- Press the **RIGHT** or **LEFT** button until the current month is set.
- Press the **UP** or **DOWN** button until **Year** is marked.
- Press the **RIGHT** or **LEFT** button until the current year is set.
- Press the **BACK** button to exit the menu.
- ✓ The date is stored.

7.23.52 Heating (function optional)

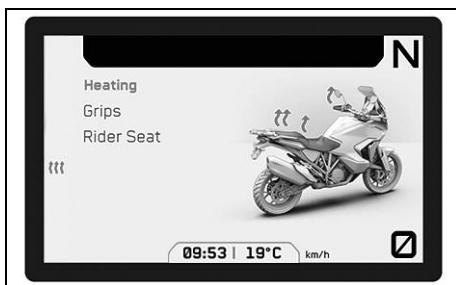

E02067-01

- Press the **SET** button or **RIGHT** button when the menu is closed.
- Press the **UP** button or **DOWN** button until **Heating** is marked.
- Press the **SET** or the **RIGHT** button to open the menu.

The grip heater (function optional) and rider's seat heating (function optional) can be configured in **Heating**.

7.23.53 Heating Grips (function optional)



Condition

- Model with grip heater.
- **Heating Grip** menu (optional function) activated.
 - Press the **UP** button or **DOWN** button until **Heating** is marked. Press the **SET** or the **RIGHT** button to open the menu.
 - Press the **UP** button or **DOWN** button until **Grips** is marked.
 - Press the **RIGHT** or **LEFT** button to select the heating level or switch the heated grips on or off.

7.23.54 Heating Rider Seat (function optional)

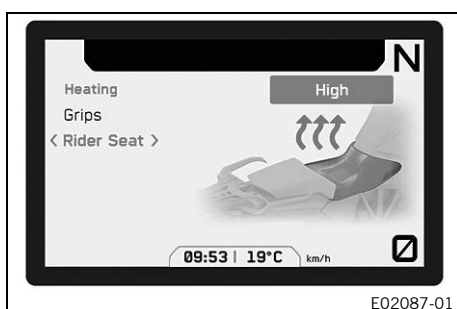

Condition

- Model with seat heater.
- **Heating Seat Rider** menu (optional function) activated.
 - Press the **UP** button or **DOWN** button until **Heating** is marked. Press the **SET** or the **RIGHT** button to open the menu.
 - Press the **UP** button or **DOWN** button until **Rider Seat** is marked.
 - Press the **RIGHT** or **LEFT** button to select the heating level or switch the front rider's seat heating on or off.



Info

The heating level for the passenger seat heating (function optional) is selected using the switch next to the right grip handle.

8.1 Handlebar position

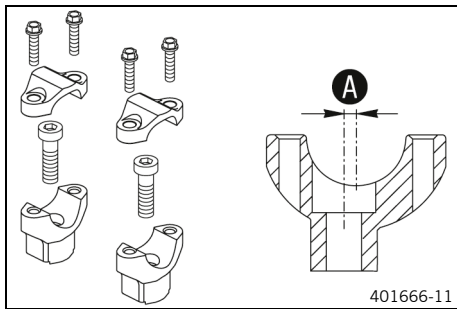

The holes on the handlebar support are placed at a distance of **A** from the center.

Hole distance A	3.5 mm (0.138 in)
------------------------	-------------------

The handlebar can be mounted in two different positions. In this way, the handlebar can be mounted in the position that is most comfortable for the rider.

8.2 Adjusting the handlebar position



Warning

Danger of accidents A repaired handlebar poses a safety risk.

If the handlebar is bent or straightened, the material becomes fatigued. The handlebar may break as a result.

- Change the handlebar if the handlebar is damaged or bent.

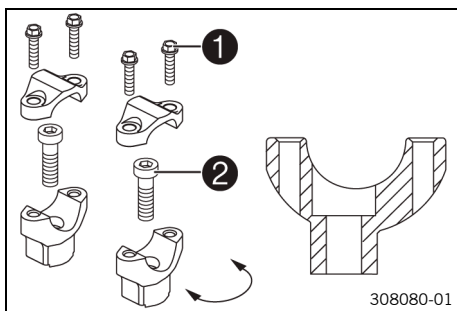

- Remove screws **1**. Remove the handlebar clamps. Remove the handlebar and lay it to one side.



Info

Cover the components to protect them against damage. Do not bend the cables and lines.

- Remove screws **2**. Take off the handlebar supports.
- Place the handlebar supports in the required position. Mount and tighten screws **2**.

Guideline

Screw, handlebar mount	M10x35	40 Nm (29.5 lbf ft) Loctite®243™
------------------------	--------	--



Info

Position the left and right handlebar supports evenly.

- Position the handlebar.



Info

Make sure the cables and wiring are positioned correctly.

- Position the handlebar clamps. Mount and evenly tighten screws **1**.

Guideline

Screw, handlebar clamp	M8x25	20 Nm (14.8 lbf ft)
------------------------	-------	---------------------

- ✓ The markings **A** of the handlebar scale are located centrally between the handlebar clamps.

- ✓ Markings **B** face backwards.

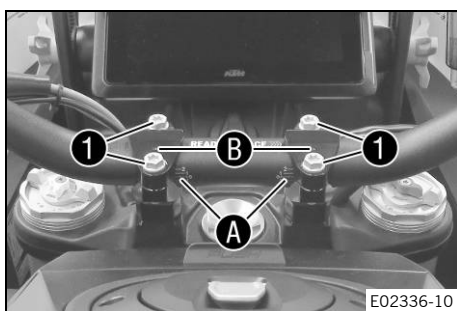

i Info
Make sure the gap widths are even.

8.3 Adjusting the windshield

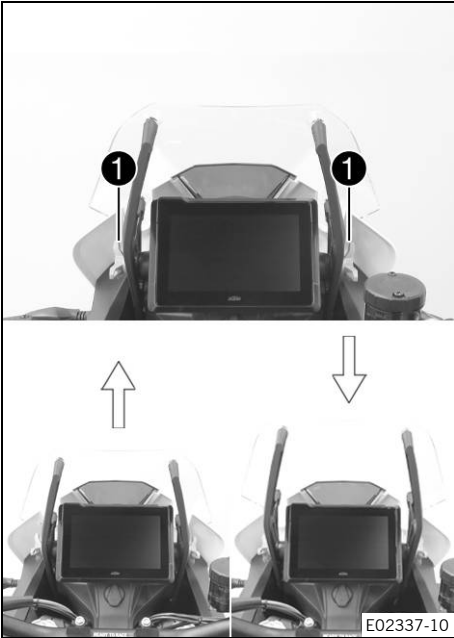

- Turn the adjusting wheel **1** to bring the windshield in the required position.

8.4 Adjusting the basic position of the clutch lever



- Adjust the basic position of the clutch lever to your hand size by turning adjusting wheel **1**.

i Info
Push the clutch lever forward and turn the adjusting wheel.
Do not make any adjustments while riding.

8.5 Adjusting the basic position of the hand brake lever



- Adjust the basic position of the hand brake lever to your hand size by turning adjusting wheel **1**.

i Info
Push the hand brake lever forward and turn the adjusting wheel.
Do not make any adjustments while riding.

8.6 Rider footrests

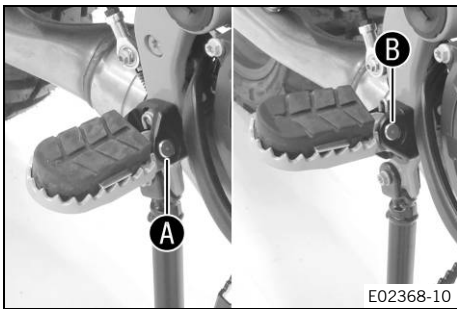

The rider footrests can be mounted in one of two positions.

Possible states

- Rider footrests, low **A**
- Rider footrests, high **B**

8.7 Adjusting the footrests



Info

The operations on the footrest brackets are the same for the left and right sides.

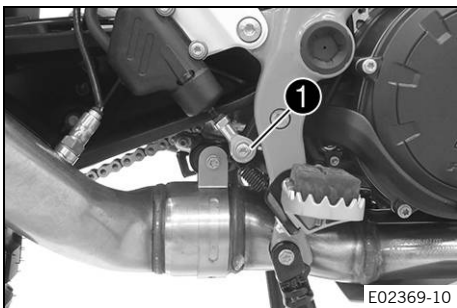

- Remove screw **1**.
- ✓ The foot brake lever swings up to the stop.

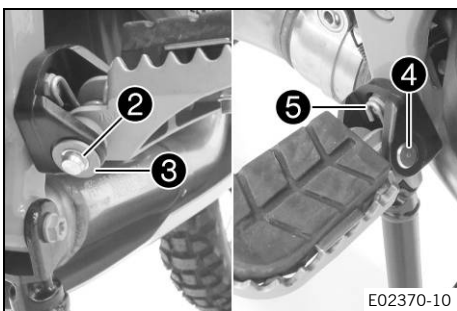

- Remove lock ring **2** with washer **3**.
- Carefully remove pin **4** of the rider footpeg.



Info

The spring is under high tension and can pop out when the pin is removed.

- Take off the rider footrest **5** with the spring.

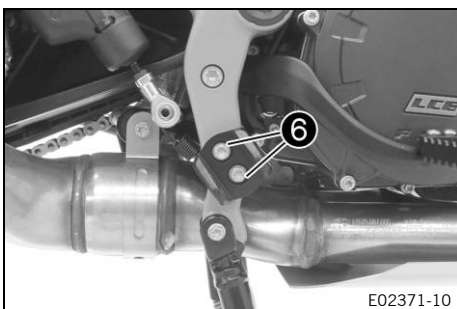

- Remove screws **6**.

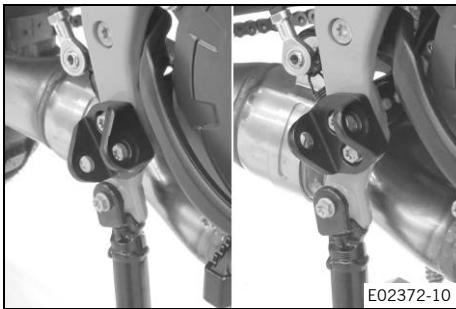

- Adjust the footrest bracket to the desired position.

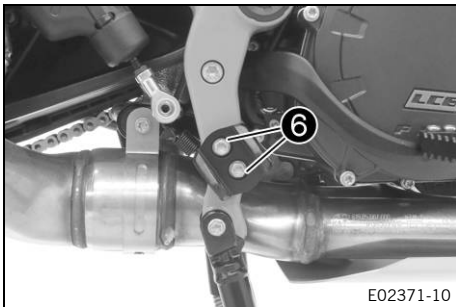

- Mount and tighten screws ⑥.

Guideline

Screw, front footrest bracket	M8x20	25 Nm (18.4 lbf ft) Loctite®243™
-------------------------------	-------	--

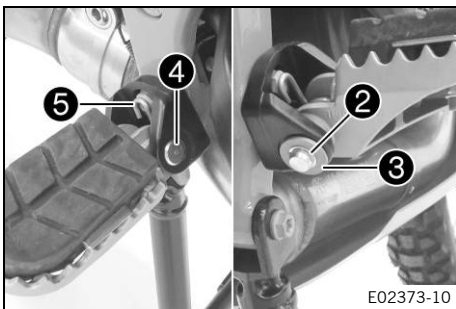

- Mount the rider footrest with spring ⑤ and pin ④.

Footrest spring plier (58429083000)

- Mount washer ③ and lock ring ②.

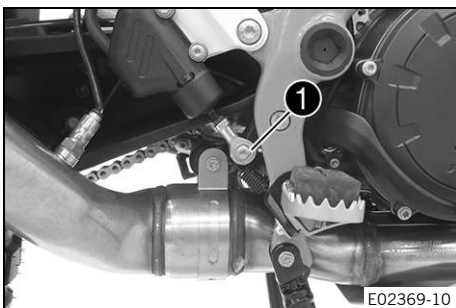

- Position the rear brake lever.
- Mount and tighten screw ①.

Guideline

Screw, ball joint of push rod on foot brake cylinder	M6	10 Nm (7.4 lbf ft) Loctite®243™
--	----	---

8.8 Checking the basic position of the shift lever

i Info

When driving, the shift lever must not touch the rider's boot when in the basic position. If the gear shift lever is permanently touching the boot, the transmission will be subject to excessive load; this can cause malfunctions of the Quickshifter.

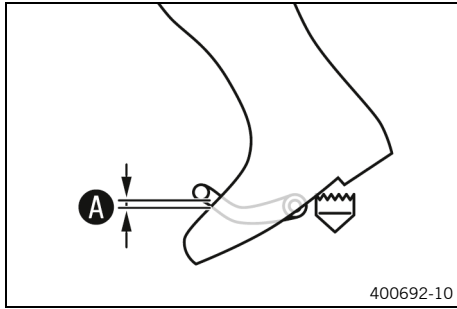

- Sit on the vehicle in the riding position and determine distance **A** between the upper edge of your boot and the gear shift lever.

Distance between shift lever and upper edge of boot	10 ... 20 mm (0.39 ... 0.79 in)
---	---------------------------------

- » If the distance does not meet specifications:
 - Adjust the basic position of the shift lever. 🛠️ (📖 p. 66)

8.9 Adjusting the basic position of the shift lever 🛠️

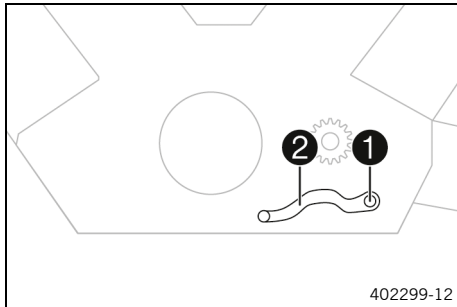

- Remove screw **1** with the washers and take off shift lever **2**.

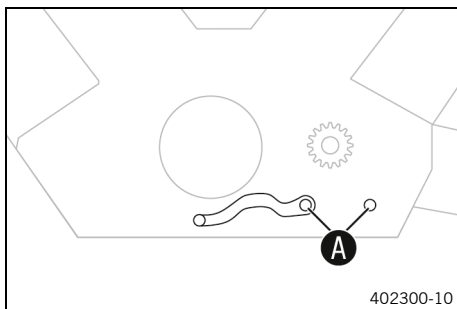

- Clean gear teeth **A** of the shift lever and shift shaft.
- Mount the shift lever on the shift shaft in the required position and engage gearing.

i Info

The range of adjustment is limited. The shift lever must not come into contact with any other vehicle components during the shift procedure.

- Mount and tighten screw **1** with washers.

Guideline

Screw, shift lever	M6x20	18 Nm (13.3 lbf ft) Loctite®243™
--------------------	-------	--

8.10 Setting the shift lever stub

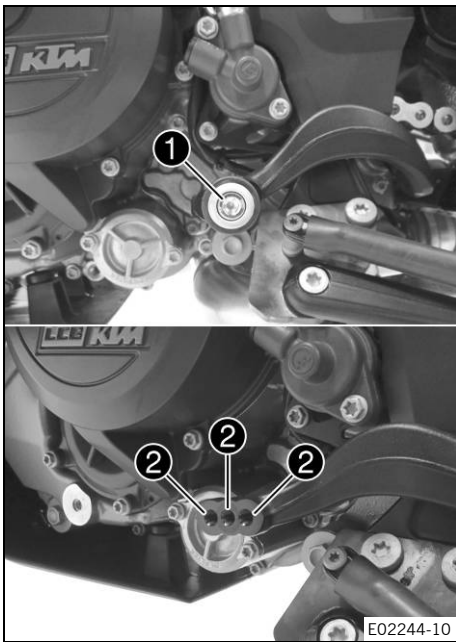

- Remove screw ① along with the shift lever stub.
- Position the shift lever stub with the screw in one of drilled holes ② depending on the desired lever length.

Guideline

Standard	Middle hole
----------	-------------

- Tighten the screw.

Guideline

Remaining screws, chassis	M6	10 Nm (7.4 lbf ft)
---------------------------	----	--------------------



8.11 Adjusting the basic position of the foot brake lever

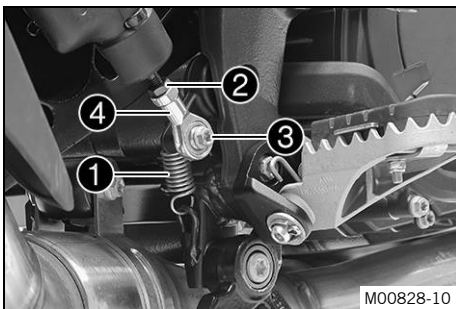

- Detach spring ①.
- Loosen nut ②.
- Remove screw ③.
- To adjust the basic position of the foot brake lever to individual requirements, turn ball joint ④ accordingly.

i Info

The range of adjustment is limited. The screw must be screwed into the ball joint by at least 5 turns.

- Hold ball joint ④ and tighten nut ②.

Guideline

Remaining nuts, chassis	M6	10 Nm (7.4 lbf ft)
-------------------------	----	--------------------

- Mount and tighten screw ③.

Guideline

Screw, ball joint of push rod on foot brake cylinder	M6	10 Nm (7.4 lbf ft) Loctite®243™
--	----	---

- Attach spring ①.



8.12 Adjusting the tilt of the combination instrument

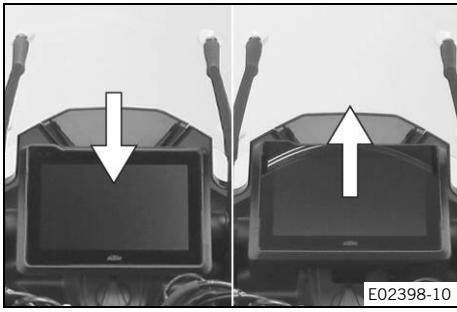

- To move the dash to the desired position, press the dash upward or downward on the lower edge.

9.1 Advice on preparing for first use

 **Danger**
Danger of accidents A rider who is not fit to ride poses a danger to him or herself and others.

- Do not operate the vehicle if you are not fit to ride due to alcohol, drugs or medication.
- Do not operate the vehicle if you are physically or mentally impaired.

 **Warning**
Risk of injury Missing or poor protective clothing presents an increased safety risk.

- Wear appropriate protective clothing such as helmet, boots, gloves as well as trousers and a jacket with protectors on all rides.
- Always wear protective clothing that is in good condition and meets the legal regulations.

 **Warning**
Danger of crashing Different tire tread patterns on the front and rear wheel impair the handling characteristic.
 Different tire tread patterns can make the vehicle significantly more difficult to control.

- Make sure that only tires with a similar tire tread pattern are fitted to the front and rear wheel.

 **Warning**
Danger of accidents Non-approved or non-recommended tires and wheels impact the handling characteristic.

- Only use tires/wheels approved by KTM with the corresponding speed index.

 **Warning**
Danger of accidents New tires have reduced road grip.
 The contact surface on new tires is not yet roughened.

- Run in new tires with moderate riding at alternating angles.
 Running-in phase 200 km (124 mi)

 **Warning**
Danger of accidents The brake system fails in the event of overheating.
 If the foot brake lever is not released, the brake linings drag continuously.

- Take your foot off the foot brake lever if you do not want to brake.

 **Info**
 When using your vehicle, remember that others may feel disturbed by excessive noise.

- Make sure that the pre-sales inspection work has been carried out by an authorized KTM workshop.
 - ✓ You will receive a delivery certificate when the vehicle is handed over.
- Before riding for the first time, read the entire Owner's Manual carefully.
- Get to know the controls.
- Adjust the motorcycle to your requirements, as described in the "Ergonomics" chapter.
- Get used to the handling characteristic of the motorcycle in a suitable area before making a longer trip. Try also to ride as slowly as possible and in a standing position to get a better feel for the motorcycle.
- Hold the handlebar firmly with both hands and keep your feet on the footrests when riding.
- Run the engine in. (📖 p. 70)



9.2 Running in the engine

- During the running-in phase, do not exceed the specified engine speed.

Guideline

Maximum engine speed	
During the first: 1,000 km (620 mi)	6,500 rpm
After the first: 1,000 km (620 mi)	10,250 rpm

- Avoid fully opening the throttle!



Info

If the maximum engine speed is exceeded before the first service, the shift warning light flashes.

9.3 Loading the vehicle



Warning

Danger of accidents Total weight and axle loads influence the handling characteristic.

The total weight consists of: motorcycle ready for operation and with a full tank, driver and passenger with protective clothing and helmet, and luggage.

- Do not exceed the maximum permissible overall weight or the axle loads.



Warning

Danger of accidents Improper mounting of cases or the tank rucksack impairs the handling characteristic.

- Mount and secure cases and tank rucksack according to the manufacturer's instructions.



Warning

Danger of accidents Carrying luggage alters handling characteristics at high speed.

- Adapt your speed to your payload.
 - Ride more slowly if your motorcycle is loaded with cases or other luggage.
- Maximum speed with luggage 150 km/h (93.2 mph)



Warning

Danger of accidents The luggage system will be damaged if it is overloaded.

- Read the manufacturer information on maximum payload when mounting cases.



Warning

Danger of accidents Luggage which has slipped impairs visibility.

If the tail light is covered, you are less visible to traffic behind you, especially when it is dark.

- Check that your luggage is fixed properly at regular intervals.



Warning

Danger of accidents A high payload alters the handling characteristic and increases the stopping distance.

- Adapt your speed to your payload.



Warning

Danger of accidents Pieces of luggage which have slipped impair the handling characteristic.

- Check that your luggage is fixed properly at regular intervals.



Warning

Fire hazard The hot exhaust system may burn luggage.

- Fasten your luggage in such a way that it cannot be burned or singed by the hot exhaust system.

- If luggage is carried, ensure it is fixed firmly as close as possible to the center of the vehicle and ensure even weight distribution between the front and rear wheels.
- Do not exceed maximum permissible weight and maximum permissible axle loads.

Guideline

Maximum permissible total weight	450 kg (992 lb.)
Maximum permissible front axle load	169 kg (373 lb.)
Maximum permissible rear axle load	281 kg (619 lb.)



10.1 Checks and maintenance measures when preparing for use

i Info

Before every trip, check the condition of the vehicle and ensure that it is roadworthy. The vehicle must be in perfect technical condition when it is being operated.

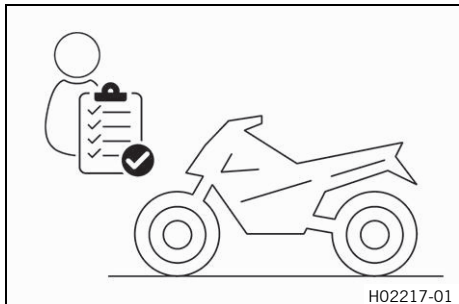

- Check the engine oil level. (📖 p. 145)
- Check the front brake fluid level. (📖 p. 115)
- Check the rear brake fluid level. (📖 p. 117)
- Check the front brake linings. (📖 p. 117)
- Check the rear brake linings. (📖 p. 119)
- Check that the brake system is functioning properly.
- Check the coolant level in the compensating tank. (📖 p. 141)
- Check the chain for dirt. (📖 p. 90)
- Check the chain tension. (📖 p. 91)
- Check the tire condition. (📖 p. 127)
- Check tire pressure. (📖 p. 128)
- Check the settings of all controls and ensure that they can be operated smoothly.
- Check that the electrical system is functioning properly.
- Check that luggage is properly secured.
- Check the setting of the rear mirror.
- Check the fuel level.

10.2 Starting



Danger

Danger of poisoning Exhaust gases are toxic and inhaling them may result in unconsciousness and death.

- Always make sure there is sufficient ventilation when running the engine.
- Use effective exhaust extraction when starting or running the engine in an enclosed space.



Caution

Danger of accidents Electronic components and safety devices will be damaged if the 12-V battery is discharged or missing.

If the 12-V battery is discharged or defective, malfunctions in the vehicle electronics can occur, especially when starting.

- Never operate the vehicle with a discharged 12-V battery or without a 12-V battery.

Note

Engine damage High revving speed with a cold engine negatively impacts the lifespan of the engine.

- Always run the engine warm at a low speed.

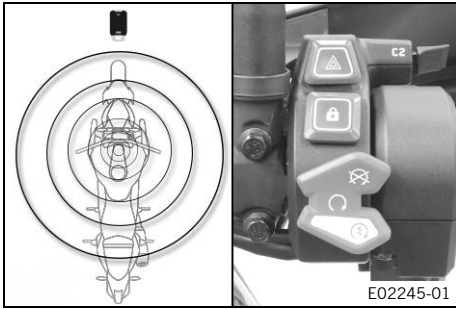

- Take the motorcycle off the side stand and sit on the motorcycle.
- Bring the RACE ON key within range of the antenna.

i Info
If the anti-relay attack mode (📖 p. 22) is active, the button on the RACE ON key must be pressed for the RACE ON key to send a response signal.

- Ensure that the RACE ON key stays in range while riding.

Guideline

Maximum range of the RACE ON key around the antenna	1.5 m (4.9 ft)
---	----------------

i Info
The range may be reduced by decreases in RACE ON key battery voltage and by interfering radio waves. If the battery voltage of the RACE ON key is too low, one of the ignition keys must be held in the area of the antenna (📖 p. 21) and must be safely stored again after starting.

- Make sure that the start button/emergency OFF switch is in the middle position (○).
- Switch on ignition; to do this, briefly press the RACE-ON button (🔑) (maximum of 1 second).
 - ✓ The steering is unlocked.
 - ✓ The function check of the combination instrument is run.
 - ✓ The ABS warning lamp goes out when starting off.

i Tip
If the handlebar does not unlock, move the handlebar slightly.

- Shift the transmission into neutral.
 - ✓ The green idle indicator lamp lights up.
- Press the start button/emergency OFF switch into the lower position (Ⓜ).



i Info
Only press the start button/emergency OFF switch into the lower position (Ⓜ) when the dash function control has been completed.
Do not open the throttle to start.
Press the start button/emergency OFF switch into the lower position (Ⓜ) for a maximum of five seconds. Wait for a least 5 seconds before trying again.
This motorcycle is equipped with a safety starting system. You can only start the engine if the transmission is in neutral or if the clutch lever is pulled when a gear is engaged. If the side stand is folded out and you shift into gear, the engine stops.



10.3 Starting off

- Pull the clutch lever, engage 1st gear, release the clutch lever slowly and simultaneously open the throttle carefully.

10.4 Quickshifter + (optional)

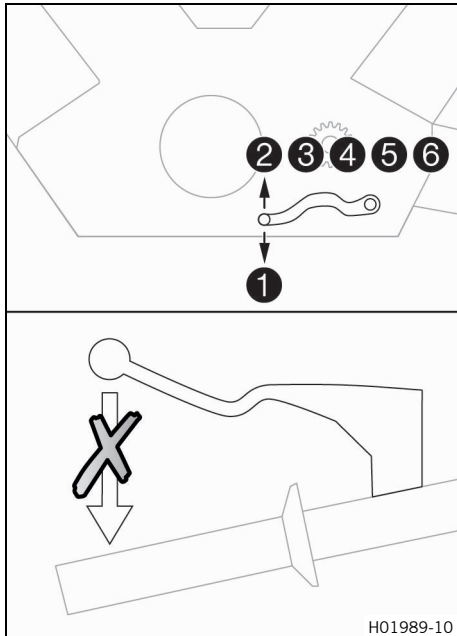

If the **quickshifter +** (optional) is activated, you can shift up and down without actuating the clutch.

Because there is no need to close the throttle grip, uninterrupted gear shifts are possible.

The quickshifter + uses the shifter shaft position to check whether or not a shift should be initiated, and sends a corresponding signal to the engine control.

If the quickshifter + is disabled in the combination instrument, the clutch needs to be actuated in the normal way for each shift.

10.5 Starting with HHC (optional)

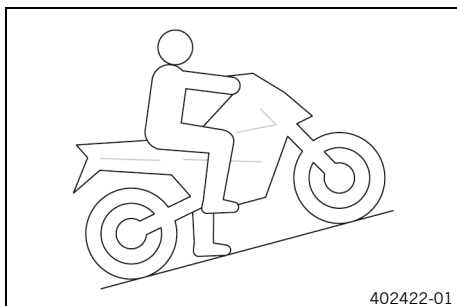

The **HHC** is an optional auxiliary function of the brake system. The **HHC** prevents accidental rolling back of the motorcycle on hills.

The **HHC** recognizes stopping on hills and operates the rear brake. After releasing the brake lever, the brake force is maintained for a maximum of 5 seconds as long as the motorcycle is not moving forward.

When driving off the **HHC** releases the rear brake automatically.

i Info

When the **HHC** is active, the TC indicator lamp flashes. When the ignition is switched on, the **HHC** can still be active even if the engine is stopped.

To roll back with active **HHC**, wait 5 seconds, shift to neutral, or switch off the ignition.

If the **HHC** does not detect a start off after 5 seconds, the braking force is automatically reduced gently.

When a brake lever is actuated, the **HHC** is re-activated.

10.6 Shifting, riding



Warning

Danger of accidents Abrupt load alterations can cause the vehicle to get out of control.

- Avoid abrupt load alterations and sudden braking actions.
- Adapt your speed to the road conditions.



Warning

Danger of accidents If you change down at high engine speed, the rear wheel blocks and the engine races.

- Do not change into a low gear at high engine speed.



Warning

Danger of accidents Adjustments to the vehicle distract attention from traffic activity.

- Make all adjustments when the vehicle is at a standstill.



Warning

Risk of injury The passenger may fall from the motorcycle if they conduct themselves incorrectly.

- Ensure that the passenger sits correctly on the passenger seat, places his or her feet on the passenger foot pegs and holds on to the rider or the grab handles.
- Note the regulations governing the minimum age of passengers in your country.



Warning

Danger of accidents A risky riding style constitutes a major risk.

- Comply with traffic regulations and ride defensively and with foresight to detect sources of danger as early as possible.



Warning

Danger of accidents Cold tires have reduced road grip.

- Ride the first miles carefully on every journey at moderate speed until the tires reach operating temperature.



Warning

Danger of accidents New tires have reduced road grip.

The contact surface on new tires is not yet roughened.

- Run in new tires with moderate riding at alternating angles.
Running-in phase 200 km (124 mi)



Warning

Danger of accidents Total weight and axle loads influence the handling characteristic.

The total weight consists of: motorcycle ready for operation and with a full tank, driver and passenger with protective clothing and helmet, and luggage.

- Do not exceed the maximum permissible overall weight or the axle loads.



Warning

Danger of accidents Pieces of luggage which have slipped impair the handling characteristic.

- Check that your luggage is fixed properly at regular intervals.



Warning

Danger of accidents A fall can damage the vehicle more seriously than it may first appear.

- Check the vehicle after a fall as you do when preparing for use.

Note

Engine damage Unfiltered intake air has a negative effect on the service life of the engine.

Dust and dirt will enter the engine without an air filter.

- Only operate the vehicle if it is equipped with an air filter.

Note

Engine failure Overheating damages the engine.

- If the coolant temperature warning is displayed, stop immediately and take care not to endanger yourself or other traffic participants in the process.
- Allow the engine and cooling system to cool down.
- Check and, if necessary, correct the coolant level on the cooling system while it is in a cooled state.

Note

Transmission damage Incorrect use of the quickshifter+ will damage the transmission.

The quickshifter+ can only be used if the function is enabled in the combination instrument.

The quickshifter+ is not active if you pull the clutch lever.

- Only use the quickshifter+ in the permitted speed range shown.



Info

If you hear unusual noises while riding, stop immediately, switch off the engine, and contact an authorized KTM workshop.

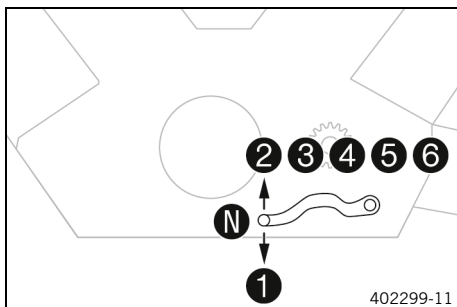

- Shift into a higher gear when conditions allow (incline, road situation, etc.).
- Release the throttle while simultaneously pulling the clutch lever, shift into the next gear, release the clutch lever, and open the throttle.



Info

The gear positions can be seen in the figure. The idle position is between the first and second gears. First gear is used for starting off or for steep inclines.

- After reaching maximum speed by fully opening the throttle grip, turn the throttle back so it is $\frac{3}{4}$ open. This will barely reduce the speed, but fuel consumption will be considerably lower.
- Accelerate only up to a speed suitable for the road surface and weather conditions. Particularly in bends, do not shift, and accelerate very carefully.
- Brake if necessary and close the throttle at the same time in order to shift down.
- Pull clutch lever and shift into a lower gear, release the clutch lever slowly, and open the throttle or shift again.
- If the engine stalls (e.g. at an intersection), just pull the clutch lever and press the start button. The transmission must not be shifted into neutral.

- Switch off the engine if you are likely to be running at idle speed or stationary for a long time.
- If the oil pressure warning lamp lights up during a trip, stop as soon as it is safe to do so and switch off the engine. Contact an authorized KTM workshop.
- If the malfunction indicator lamp lights up during a trip, please contact an authorized KTM workshop as soon as possible.
- If the general warning lamp lights up during a trip, the display shows a message for 10 seconds.

i Info
Very important messages are stored in the **Warning** menu.

- If the ice warning ❄ appears on the combination instrument, there may be black ice on the road surface. Adjust your speed to the road conditions.

Condition

The quickshifter + (optional) is enabled.

- If the quickshifter + is enabled in the combination instrument, one can shift up in the engine speed range shown without pulling the clutch lever.

i Info
The minimum engine speed before shifting up in revolutions per minute is shown in the figure. Pull the shift lever to the stop quickly without changing the throttle twist grip position.

- If the quickshifter + is enabled in the combination instrument, one can shift down in the engine speed range shown without pulling the clutch lever.

i Info
The maximum engine speed before shifting down in revolutions per minute is shown in the figure. Depress the shift lever to the stop quickly without changing the throttle twist grip position.

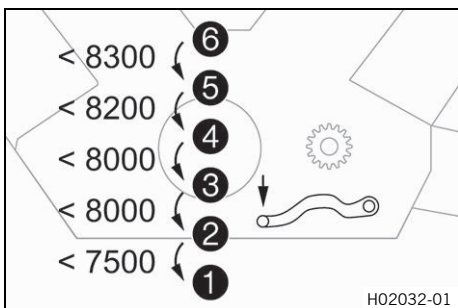
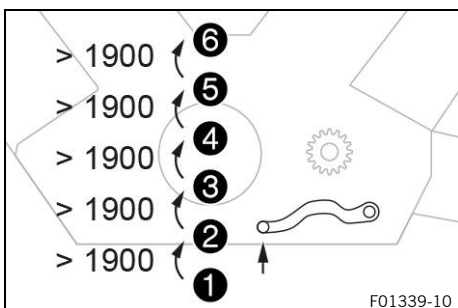

10.7 MSR (optional)

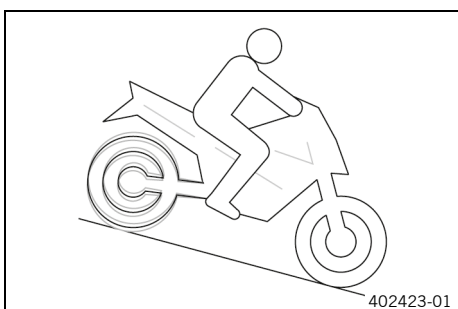

The **MSR** is an optional auxiliary function of the engine control. If the engine braking effect is too great, the **MSR** prevents the rear wheel from locking or sliding away on a sloping position. To avoid slip of the rear wheel, the **MSR** only opens the throttle valve as far as absolutely necessary. The **MSR** is applied on surfaces, where the friction coefficient is too low to open the slipper clutch. To further increase ride safety, the **MSR** is slope dependent.



Info

If ABS is disabled, MTC is disabled or ABS Mode **Offroad** is enabled, the **MSR** is not active.

10.8 Braking



Warning

Danger of accidents Moisture and dirt impair the brake system.

- Brake carefully several times to dry out and remove dirt from the brake linings and the brake discs.



Warning

Danger of accidents A spongy pressure point on the front or rear brake reduces braking efficiency.

- Check the brake system and do not continue riding until the problem is eliminated. (Your authorized KTM workshop will be glad to help.)



Warning

Danger of accidents The brake system fails in the event of overheating.

If the foot brake lever is not released, the brake linings drag continuously.

- Take your foot off the foot brake lever if you do not want to brake.



Warning

Danger of accidents Higher total weight increases the stopping distance.

- Take the longer stopping distance into account when carrying a passenger or luggage with you.



Warning

Danger of accidents Salt on the roads impairs the brake system.

- Brake carefully several times to remove salt from the brake linings and the brake discs.



Warning

Danger of accidents ABS may increase the stopping distance in certain situations.

- Adjust application of the brakes to the respective riding situation and riding surface conditions.



Warning

Danger of accidents Excessively forceful application of the brakes blocks the wheels.

The ABS effectiveness is only ensured if it is switched on.

- Leave the ABS switched on in order to benefit from the protective effect.



Warning

Danger of accidents Driving aids can reduce the probability of a fall only within physical limits.

It is not always possible to compensate for extreme riding situations, for example with luggage loaded with a high center of gravity, varying road surfaces, steep descents or full braking without disengaging the gear.

- Adapt your riding style to the road conditions and your driving ability.

- When braking, release the throttle and apply the front and rear brakes at the same time.



Info

When the ABS is enabled, maximum braking power can be achieved even on surfaces with low road grip such as sandy, wet, or slippery terrain without the danger of the wheels locking.

**Warning****Danger of accidents** The rear wheel can lock due to the engine braking effect.

- Pull in the clutch, if you perform emergency or full braking, or if you brake on a slippery ground.

**Warning****Danger of accidents** Banked or laterally sloping ground reduces the maximum possible delay.

- If possible finish braking before going into a bend.

- Always finish braking before the beginning of the curve. Shift down to a lower gear appropriate to your speed.
- Use the braking effect of the engine on long downhill stretches. To do so, shift back one or two gears, but do not overrev the engine. This means that significantly less braking is required and the brake system does not overheat.

**10.9 Stopping, parking****Warning****Risk of injury** People who act without authorization endanger themselves and others.

If a valid transponder is in range, the vehicle can be started.

- Do not leave the vehicle unattended if the engine is running.
- Never leave the vehicle unattended if the RACE-ON key or the black ignition key are close to the vehicle.
- Protect the vehicle against access by unauthorized persons.
- Lock the steering if you leave the vehicle unattended.

**Warning****Danger of burns** Some vehicle components become very hot when the vehicle is operated.

- Do not touch any parts such as the exhaust system, radiator, engine, shock absorber, or brake system before the vehicle parts have cooled down.
- Let the vehicle parts cool down before you perform any work on the vehicle.

Note**Fire hazard** Hot vehicle components pose a fire hazard and explosion risk.

- Do not park the vehicle near to materials which are highly flammable or explosive.
- Allow the vehicle to cool down before covering it.

Note**Material damage** The vehicle may be damaged by incorrect procedure when parking.

Significant damage may be caused if the vehicle rolls away or falls over.

The components for parking the vehicle are designed only for the weight of the vehicle.

- Park the vehicle on a firm and level surface.
 - Ensure that nobody sits on the vehicle when the vehicle is parked on a stand.
-
- Apply the brakes on the motorcycle.
 - Shift the transmission into neutral.
 - Switch off ignition – to do this, briefly press the RACE-ON button  (maximum of 1 second) with the ignition switched on.

i Info

If the engine is switched off with the emergency OFF switch and the ignition remains switched on using the RACE-ON button, the power supply to most electrical power consumers remains uninterrupted. This discharges the 12-V battery. You should therefore always switch off the engine with the RACE-ON button – the emergency OFF switch is intended for emergencies only.

- Park the motorcycle on a firm surface.

Alternative 1

- Swing side stand forward with your foot as far as it will go and lean the vehicle on it.

Alternative 2

- Raise the vehicle with the center stand. (📖 p. 89)
- Move handlebar fully to the left and press and hold the RACE-ON button  (for at least 2 seconds).
 - ✓ The steering is locked.

i Info

If the steering lock does not engage, move the handlebar slightly.

10.10 Transporting

Note

Danger of damage The parked vehicle can roll away or fall over.

- Park the vehicle on a firm and level surface.

Note

Fire hazard Hot vehicle components pose a fire hazard and explosion risk.

- Do not park the vehicle near to materials which are highly flammable or explosive.
- Allow the vehicle to cool down before covering it.

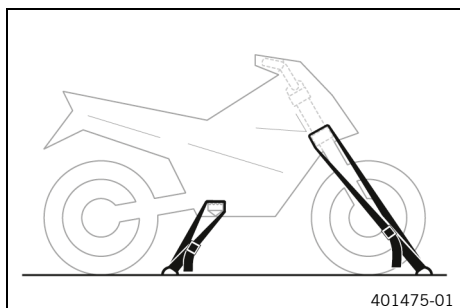

- Switch off the engine.
- Use tension belts or other suitable devices to secure the motorcycle against falling over or rolling away.

10.11 Refueling



Danger

Fire hazard Fuel is highly flammable.

The fuel in the fuel tank expands when warm and can escape if overfilled.

- Do not fuel the vehicle in the vicinity of open flames or lit cigarettes.
- Switch off the engine for refueling.
- Make sure that no fuel is spilled; particularly not on hot parts of the vehicle.
- If any fuel is spilled, wipe it off immediately.
- Observe the specifications for refueling.



Warning

Danger of poisoning Fuel is poisonous and a health hazard.

- Avoid skin, eye and clothing contact with fuel.
- Immediately consult a doctor if you swallow fuel.
- Do not inhale fuel vapors.
- In case of skin contact, rinse the affected area with plenty of water.
- Rinse the eyes thoroughly with water, and consult a doctor in case of fuel contact with the eyes.
- Change your clothing in case of fuel spills on them.

Note

Material damage Inadequate fuel quality causes the fuel filter to quickly become clogged.

In some countries and regions, the available fuel quality and cleanliness may not be sufficient. This will result in problems with the fuel system.

- Refuel only with clean fuel that meets the specified standards. (Your authorized KTM workshop will be glad to help.)



Note

Environmental hazard Improper handling of fuel is a danger to the environment.

- Do not allow fuel to enter the groundwater, the soil, or the sewage system.

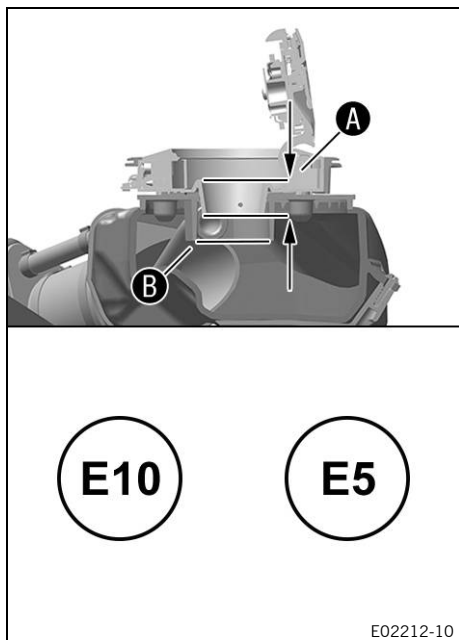

- Switch off the engine.
- Open the fuel tank filler cap. (📖 p. 23)
- Only insert the fuel nozzle to the specified dimension.

Guideline

Dimension A	2.5 cm (0.98 in)
--------------------	------------------

- Fill the fuel up to the maximum level at lower edge **B** of the filler neck.

Guideline

After filling up to the lower edge of the filler neck for the first time, do not refuel again.

Total fuel tank capacity, approx.	23 l (6.1 US gal)	Super unleaded (ROZ 95) (📖 p. 171)
-----------------------------------	----------------------	---------------------------------------

i Info

After the first filling, the contents of the reservoir slowly flows into the fuel tank.

If refueling is performed again after draining, the fuel tank will overfill and the evaporative canister will be destroyed.

- Close the fuel tank filler cap. (📖 p. 24)



11.1 Additional information

Any further work that results from the compulsory work or from the recommended work must be ordered separately and invoiced separately.

Different service intervals may apply in your country, depending on the local operating conditions.

Individual service intervals and scopes may change in the course of technical developments. The most up-to-date service schedule can always be found on KTM Dealer.net. Your authorized KTM dealer will be happy to advise you.

11.2 Required work

	every 24 months	every 12 months	every 30,000 km (18,600 mi)	every 15,000 km (9,300 mi)	after 1,000 km (620 mi)
Read out the fault memory using the KTM diagnostics tool. 🛠️	○	●	●	●	●
Program the shift shaft sensor. 🛠️	○	●	●	●	●
Check that the electrical system is functioning properly. 🛠️	○	●	●	●	●
Change the engine oil and the oil filter, clean the oil screens. 🛠️ (📖 p. 145)	○	●	●	●	●
Check the front brake linings. (📖 p. 117)	○	●	●	●	●
Check the rear brake linings. (📖 p. 119)	○	●	●	●	●
Check the brake discs. (📖 p. 114)	○	●	●	●	●
Check the brake lines for damage and tightness. 🛠️	○	●	●	●	●
Change the front brake fluid. 🛠️					●
Change the rear brake fluid. 🛠️					●
Change the hydraulic clutch fluid. 🛠️					●
Check the front brake fluid level. (📖 p. 115)	○	●	●	●	
Check the rear brake fluid level. (📖 p. 117)	○	●	●	●	
Check/correct the fluid level of the hydraulic clutch. (📖 p. 94)		●	●	●	
Check the shock absorber and fork for leaks. Perform service as needed and depending on how the vehicle is used. 🛠️	○	●	●	●	●
Clean the dust boots of the fork legs. 🛠️ (📖 p. 110)		●	●		
Check the steering head bearing for play. 🛠️	○	●	●	●	●
Check the tire condition. (📖 p. 127)	○	●	●	●	●
Check tire pressure. (📖 p. 128)	○	●	●	●	●
Retighten the spokes. 🛠️	○				
Check the rim run-out. 🛠️	○	●	●	●	●
Check the spoke tension. (📖 p. 128)		●	●	●	●
Check the chain, rear sprocket, and engine sprocket. (📖 p. 93)		●	●	●	●
Check the chain tension. (📖 p. 91)	○	●	●	●	●
Change the spark plugs (air filter removed). 🛠️				●	
Check the valve clearance (air filter and spark plugs removed). 🛠️				●	
Change the SAS diaphragm valves. 🛠️				●	
Check the cables for damage and for routing without kinks. (fuel tank removed) 🛠️		●	●	●	●
Check the coolant level in the compensating tank. (📖 p. 141)	○	●	●	●	●
Change the air filter, clean the air filter box. 🛠️		●	●		
Check the fuel pressure. 🛠️		●	●	●	●

	every 24 months				
	every 12 months				
	every 30,000 km (18,600 mi)				
	every 15,000 km (9,300 mi)				
	after 1,000 km (620 mi)				
Check the headlight setting. (📖 p. 138)	○	●	●	●	●
Check that the radiator fan is functioning properly. 🛠️	○	●	●	●	●
Final check: Check the vehicle is roadworthy and take a test ride. 🛠️	○	●	●	●	●
Read out the error memory after the test ride using the KTM diagnostics tool. 🛠️	○	●	●	●	●
Set the service interval display. 🛠️	○	●	●	●	●
Make a service entry in KTM Dealer.net . 🛠️	○	●	●	●	●

- One-time interval
- Periodic interval

11.3 Recommended work

	every 48 months				
	every 12 months				
	every 30,000 km (18,600 mi)				
	every 15,000 km (9,300 mi)				
	after 1,000 km (620 mi)				
Check the frame. 🛠️				●	
Check the link fork. 🛠️				●	
Check/clean the oil nozzle for clutch lubrication. 🛠️	○	●	●		
Check the swingarm bearing for play. 🛠️		●	●		
Check the wheel bearing for play. 🛠️		●	●		
Grease all moving parts (e.g. side stand, hand lever, chain, etc.) and check for smooth operation. 🛠️	○	●	●	●	●
Empty the drainage hoses. 🛠️	○	●	●	●	●
Check all hoses (e.g. fuel, cooling, bleeder, drainage hoses, etc.) and sleeves for cracking, tightness, and correct routing. 🛠️		●	●	●	●
Check the tightness of the safety-relevant screws and nuts which are easily accessible. 🛠️	○	●	●	●	●
Check the antifreeze. 🛠️	○	●	●	●	
Change the coolant. 🛠️					●

- One-time interval
- Periodic interval

12.1 Fork/shock absorber

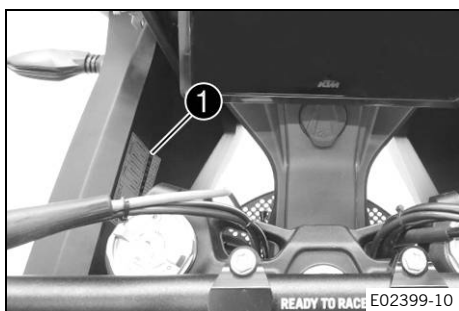

The fork and the shock absorber offer many options of adapting the suspension to the riding style and the payload.

i Info

The recommendations for the suspension setting are shown in table 1. The table is found on the left inside cover.

These adjustments are guidelines and should always be the basis for a suspension setting. If the guidelines are not adhered to, the riding characteristics could deteriorate, particularly at high speeds.

12.2 Adjusting the compression damping of the fork

i Info

The hydraulic compression damping determines the fork suspension behavior.

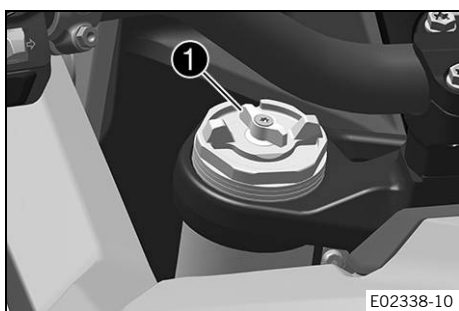

- Turn white adjusting screw 1 clockwise as far as it will go.

i Info

Adjusting screw 1 is located at the upper end of the left fork leg. The compression damping is located in left fork leg **COMP** (white adjusting screw). The rebound damping is located in right fork leg **REB** (red adjusting screw).

- Turn counterclockwise by the number of clicks corresponding to the fork type.

Guideline

Compression damping	
Comfort	21 clicks
Standard	15 clicks
Sport	10 clicks
Full payload	10 clicks

i Info

Turn clockwise to increase damping; turn counterclockwise to reduce damping during compression.

12.3 Adjusting the rebound damping of the fork

i **Info**

The hydraulic rebound damping determines the fork suspension behavior.

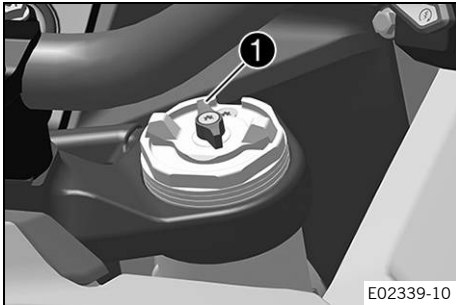

E02339-10

- Turn red adjusting screw **1** clockwise as far as it will go.

i **Info**

Adjusting screw **1** is located at the upper end of the right fork leg.
The rebound damping is located in right fork leg **REB** (red adjusting screw). The compression damping is located in left fork leg **COMP** (white adjusting screw).

- Turn counterclockwise by the number of clicks corresponding to the fork type.

Guideline

Rebound damping	
Comfort	21 clicks
Standard	15 clicks
Sport	10 clicks
Full payload	10 clicks

i **Info**

Turn clockwise to increase the damping; turn counterclockwise to reduce damping when the shock absorber rebounds.



12.4 Adjusting the spring preload of the fork

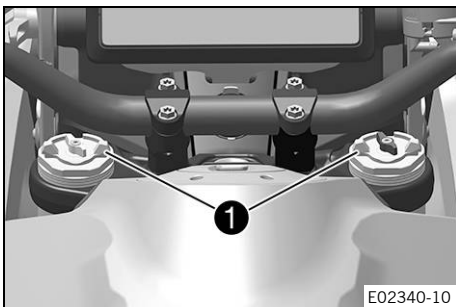

E02340-10

- Turn T-grips **1** counterclockwise all the way.
- ✓ Marking **+0** aligns with the right-hand part of the grip.

i **Info**

Make the adjustment by hand only. Do not use a tool.
Make the same adjustment on both fork legs.

- Turn the T-grips clockwise.

Guideline

Spring preload – preload adjuster	
Comfort	0 turns
Standard	0 turns
Sport	0 turns
Full payload	6 turns

- ✓ The T-grips engage noticeably at the numerical values.

i Info

Adjust the spring preload to the numerical values only as the preload will not engage between the numerical values.

Turn clockwise to increase the spring preload; turn counterclockwise to reduce the spring preload.

Adjusting the spring preload has no influence on the absorption setting of the rebound.

Basically, however, you should set the rebound damping higher with a higher spring preload.

12.5 Compression damping of the shock absorber

The compression damping of the shock absorber is divided into two ranges: high-speed and low-speed. High-speed and low-speed refer to the compression speed of the rear wheel suspension and not to the vehicle speed.

The high-speed compression adjuster, for example, has an effect when riding over an asphalt edge: the rear wheel suspension compresses quickly.

The low-speed compression adjuster has an effect, for example, when riding over long ground swells: the rear wheel suspension compresses slowly.

These two ranges can be adjusted separately, although the transition between high-speed and low-speed is gradual. Thus, modifications in the high-speed range affect the compression damping in the low-speed range and vice versa.

12.6 Adjusting the low-speed compression damping of the shock absorber

! Caution

Risk of injury Parts of the shock absorber will move around if the shock absorber is detached incorrectly. The shock absorber is filled with highly compressed nitrogen.

- Please follow the description provided. (Your authorized KTM workshop will be glad to help.)

i Info

The effect of the low-speed compression adjuster can be seen in slow to normal compression of the shock absorber.

Condition

The rear right side fairing has been removed.

- Turn adjusting screw **1** clockwise with a screwdriver as far as the last perceptible click.

i Info

Do not loosen fitting **2**!

- Turn counterclockwise by the number of clicks corresponding to the shock absorber type.

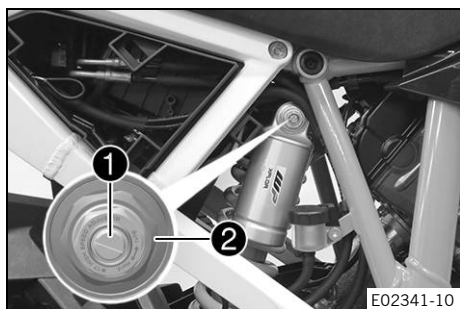

E02341-10

Guideline

Low-speed compression damping	
Comfort	21 clicks
Standard	15 clicks
Sport	10 clicks
Full payload	7 clicks

i Info
Turn clockwise to increase damping; turn counterclockwise to reduce damping.



12.7 Adjusting the high-speed compression damping of the shock absorber

! Caution
Risk of injury Parts of the shock absorber will move around if the shock absorber is detached incorrectly. The shock absorber is filled with highly compressed nitrogen.
– Please follow the description provided. (Your authorized KTM workshop will be glad to help.)

i Info
The effect of the high speed DCC can be seen in fast compression of the shock absorber.

Condition

The rear right side fairing has been removed.

- Turn adjusting screw **1** all the way clockwise with a socket wrench.

i Info
Do not loosen fitting **2**!

- Turn counterclockwise by the number of turns corresponding to the shock absorber type.

Guideline

High-speed compression damping	
Comfort	1.5 turns
Standard	1.5 turns
Sport	1 turn
Full payload	1 turn

i Info
Turn clockwise to increase damping; turn counterclockwise to reduce damping.

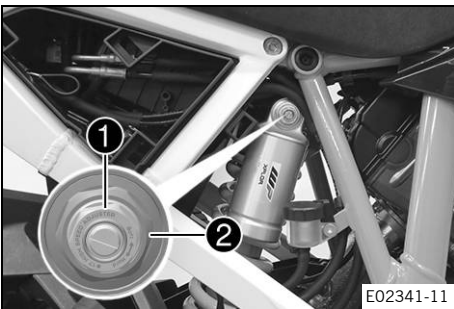

12.8 Adjusting the rebound damping of the shock absorber



Caution

Risk of injury Parts of the shock absorber will move around if the shock absorber is detached incorrectly. The shock absorber is filled with highly compressed nitrogen.

- Please follow the description provided. (Your authorized KTM workshop will be glad to help.)

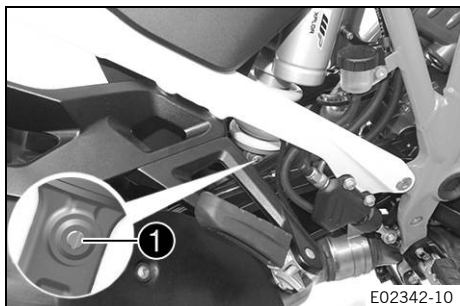

E02342-10

- Turn adjusting screw ❶ clockwise up to the last perceptible click.
- Turn counterclockwise by the number of clicks corresponding to the shock absorber type.

Guideline

Rebound damping	
Comfort	21 clicks
Standard	15 clicks
Sport	10 clicks
Full payload	7 clicks



Info

Turn clockwise to increase the damping; turn counterclockwise to reduce damping when the shock absorber rebounds.

12.9 Adjusting the spring preload of the shock absorber

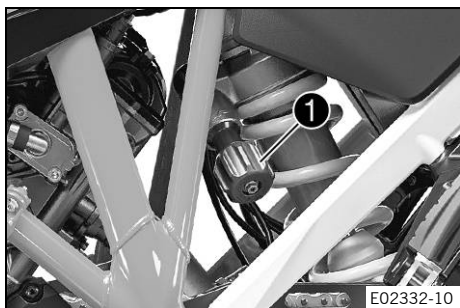

E02332-10

- Turn handwheel ❶ counterclockwise as far as it will go.
- Turn it clockwise by the number of turns corresponding to the shock absorber type and use.

Guideline

Preload adjuster	
Standard Street	5 turns
Standard Offroad	1 turn
Full payload	26 turns



Info

Turn clockwise to increase the spring preload; turn counterclockwise to reduce the spring preload.

13.1 Raising the vehicle with the center stand

Note

Material damage The vehicle may be damaged by incorrect procedure when parking. Significant damage may be caused if the vehicle rolls away or falls over. The components for parking the vehicle are designed only for the weight of the vehicle.

- Park the vehicle on a firm and level surface.
- Ensure that nobody sits on the vehicle when the vehicle is parked on a stand.

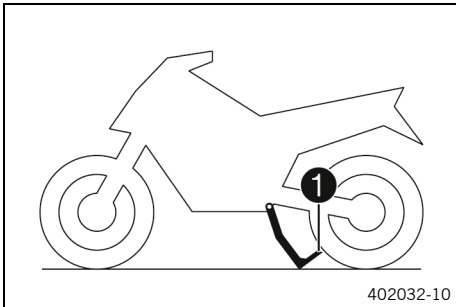

- Stand to the left of the vehicle.
- Hold the handlebar with your left hand and push the center stand onto the ground with your right foot.
- Put your entire weight on arm ① of the center stand while pulling the vehicle up at the left grab handle.
- ✓ The center stand is folded out to the stop.



13.2 Removing the vehicle from the center stand

Note

Danger of damage The parked vehicle can roll away or fall over.

- Park the vehicle on a firm and level surface.

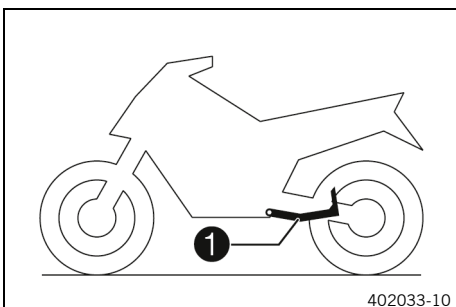

- Make sure that the steering is unlocked.
- Move the vehicle forward with both hands on the handlebar.
- While the vehicle tips off the center stand, actuate the front brake to stop the vehicle from rolling away.
- Check that the center stand ① is folded all the way up.



13.3 Removing the seat

Condition

The motorcycle is stationary.

The engine is off.

The ignition has been switched on or off for less than 1 minute.

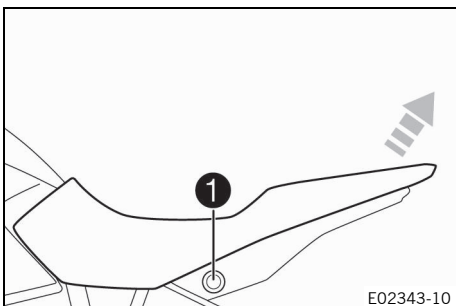

- Press seat release button ①.
- Raise the rear of the seat, pull the seat back, and lift it off upward.



13.4 Mounting the seat

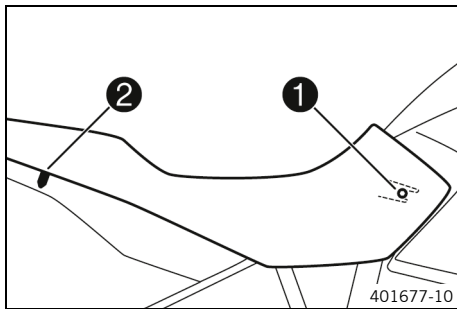

- Hook holding lug **1** of the seat onto the fuel tank, lower the rear and push it forward.
- Insert locking pin **2** into the lock housing and push down the rear of the seat until the locking pin engages with a click.
- Check that the seat is correctly mounted.

13.5 Checking for chain dirt

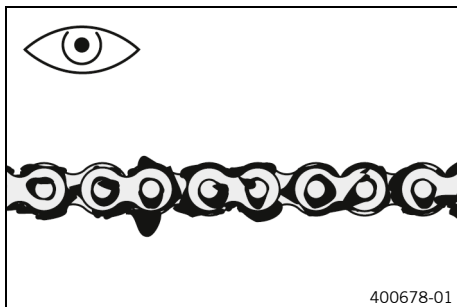

- Check the chain for coarse dirt accumulation.
 - » If the chain is very dirty:
 - Clean the chain. (📖 p. 90)

13.6 Cleaning the chain



Warning

Danger of accidents Lubricants on the tires reduces the road grip.

- Remove lubricants from the tires using a suitable cleaning agent.



Warning

Danger of accidents Oil or grease on the brake discs reduces the braking effect.

- Always keep the brake discs free of oil and grease.
- Clean the brake discs with brake cleaner when necessary.



Note

Environmental hazard Hazardous substances cause environmental damage.

- Dispose of oils, grease, filters, fuel, cleaning agents, brake fluid, etc., correctly and in compliance with the applicable regulations.



Info

The service life of the chain depends largely on its maintenance.

Preparatory work

- Raise the vehicle with the center stand. (📖 p. 89)

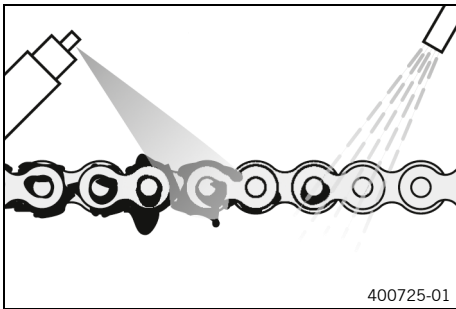

Main work

- Rinse off loose dirt with a soft jet of water.
- Remove old grease residue with chain cleaner.

Chain cleaner (📖 p. 172)

- After drying, apply chain spray.

Street chain spray (📖 p. 172)

Finishing work

- Remove the vehicle from the center stand. (📖 p. 89)



13.7 Checking the chain tension



Warning

Danger of accidents Incorrect chain tension damages components and results in accidents.

If the chain is tensioned too much, the chain, engine sprocket, rear sprocket, transmission and rear wheel bearings wear more quickly. Some components may break if overloaded.

If the chain is too loose, the chain may fall off the engine sprocket or the rear sprocket. As a result, the rear wheel locks or the engine will be damaged.

- Check the chain tension regularly.
- Set the chain tension in accordance with the specification.

Preparatory work

- Raise the vehicle with the center stand. (📖 p. 89)

Main work

- Shift the transmission into neutral.
- Insert the screwdriver into recess ❶ of the chain guide between the chain and swingarm while pushing the screwdriver upward slightly.

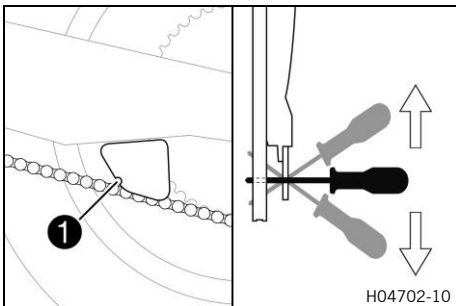

Info

The top part of the chain must be taut.

Chain wear is not always even, so you should repeat this measurement at different chain positions.

The chain tension is correctly set when the screwdriver is parallel to the ground.

- » If the screwdriver points downwards, the chain tension is too high:
 - Adjust the chain tension. (📖 p. 92)
- » If the screwdriver points upwards, the chain tension is too low:
 - Adjust the chain tension. (📖 p. 92)

Finishing work

- Remove the vehicle from the center stand. (📖 p. 89)



13.8 Adjusting the chain tension



Warning

Danger of accidents Incorrect chain tension damages components and results in accidents.

If the chain is tensioned too much, the chain, engine sprocket, rear sprocket, transmission and rear wheel bearings wear more quickly. Some components may break if overloaded.

If the chain is too loose, the chain may fall off the engine sprocket or the rear sprocket. As a result, the rear wheel locks or the engine will be damaged.

- Check the chain tension regularly.
- Set the chain tension in accordance with the specification.

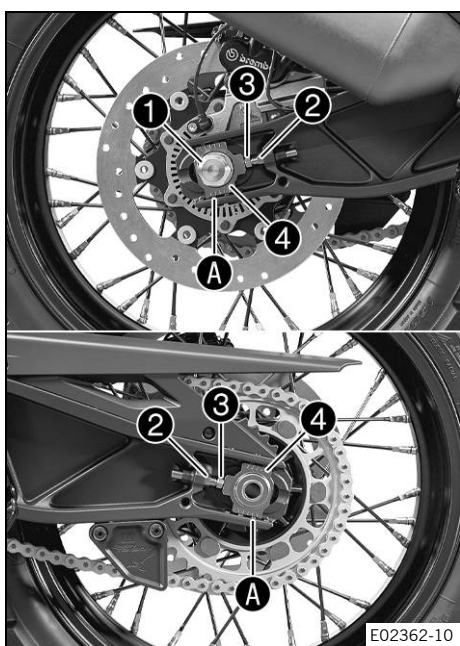

Preparatory work

- Raise the vehicle with the center stand. (📖 p. 89)
- Check the chain tension. (📖 p. 91)

Main work

- Loosen nut ①.
- Loosen nuts ②.
- Adjust the chain tension by turning adjusting screws ③ left and right.

Guideline

The chain tension is correctly set when the screwdriver is parallel to the ground.

Turn adjusting screws ③ on the left and right so that the markings on left and right chain tension adjusters ④ are in the same position relative to reference marks A. The rear wheel is then correctly aligned.

i Info

The top part of the chain must be taut.

Chain wear is not always even, so you should check the setting at different chain positions.

- Tighten nuts ②.
- Make sure that chain adjusters ④ are fitted correctly on adjusting screws ③.
- Tighten nut ①.

Guideline

Nut, rear wheel spindle	M25x1.5	90 Nm (66.4 lbf ft) Thread greased
-------------------------	---------	---------------------------------------

i Info

Chain adjusters ④ can be turned by 180°.

Finishing work

- Remove the vehicle from the center stand. (📖 p. 89)

13.9 Checking the chain, rear sprocket, and engine sprocket

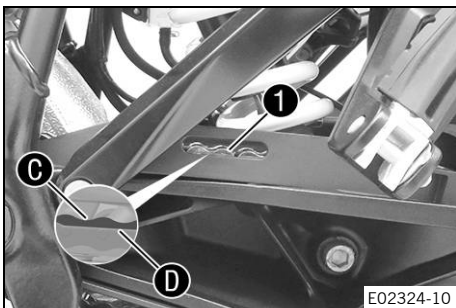
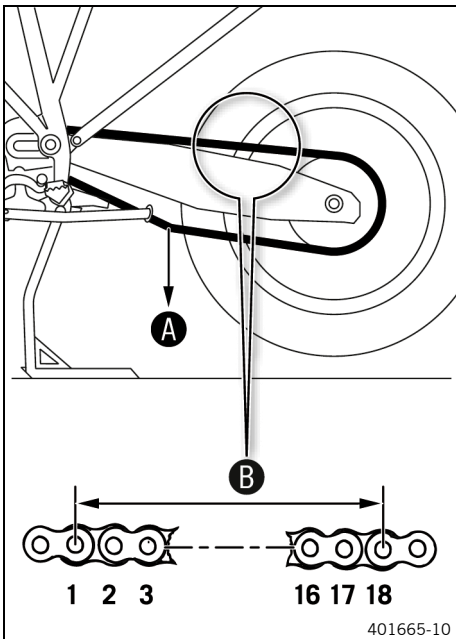
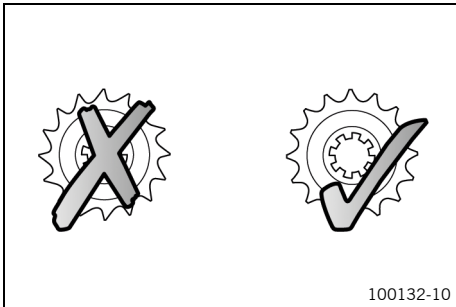

Preparatory work

- Raise the vehicle with the center stand. (📖 p. 89)

Main work

- Check the chain, rear sprocket and front sprocket for wear.
 - » If the chain, rear sprocket or front sprocket is worn:
 - Change the drivetrain kit. 🛠️

i Info
The front sprocket, rear sprocket and chain should always be replaced together.

- Shift the transmission into neutral.
- Pull on the lower chain section with specified weight **A**.

Guideline

Weight, chain wear measurement	15 kg (33 lb.)
--------------------------------	----------------

- Measure distance **B** of 18 chain rollers in the upper chain section.

i Info
Chain wear is not always even, so you should repeat this measurement at different chain positions.

Maximum distance B from 18 chain rollers at the longest chain section	272 mm (10.71 in)
--	-------------------

- » If distance **B** is greater than the specified measurement:
 - Change the drivetrain kit. 🛠️

i Info
When a new chain is mounted, the rear sprocket and the engine sprocket should also be changed.
New chains wear out faster on old, worn sprockets.
For safety reasons, the chain has no chain joint.

- Check chain sliding guard for wear at the recess.

i Info
When the chain slider is new, one third of surface area **C** of chain links **1** is visible at bottom edge **D** of the recess.

- » If surface area **C** of the chain links is no longer visible on bottom edge **D** of the recess:
 - Change the chain sliding guard. 🛠️

- Check that the chain slider is firmly seated.
 - » If the chain sliding guard is loose:

- Tighten screws on the chain sliding guard.

Guideline

Screw, chain sliding guard	M5x10	5 Nm (3.7 lbf ft)
----------------------------	-------	-------------------

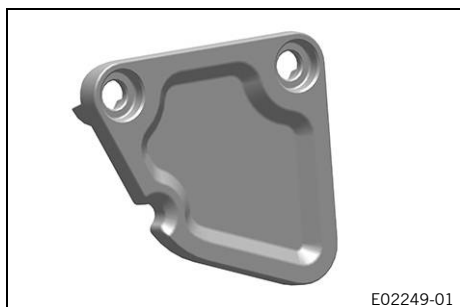

- Check the chain guide for wear.
 - » If the chain guide is worn:
 - Change the chain guide. 🛠️
- Check that the chain guide is firmly seated.
 - » If the chain guide is loose:
 - Tighten the screws on the chain guide.

Guideline

Screw, chain guide	M6	5 Nm (3.7 lbf ft)
--------------------	----	-------------------

Finishing work

- Remove the vehicle from the center stand. (📖 p. 89)

13.10 Checking/correcting the fluid level of the hydraulic clutch



Warning

Skin irritation Brake fluid causes skin irritation.

- Keep brake fluid out of the reach of children.
- Wear suitable protective clothing and safety glasses.
- Do not allow brake fluid to come into contact with the skin, the eyes or clothing.
- Consult a doctor immediately if brake fluid has been swallowed.
- Rinse the affected area with plenty of water in the event of contact with the skin.
- Rinse eyes thoroughly with water immediately and consult a doctor if brake fluid comes into contact with the eyes.
- If brake fluid spills on to your clothing, change the clothing.



Note

Environmental hazard Hazardous substances cause environmental damage.

- Dispose of oils, grease, filters, fuel, cleaning agents, brake fluid, etc., correctly and in compliance with the applicable regulations.



Info

The fluid level rises with increasing wear of the clutch facing discs. Never use DOT 5 brake fluid. It is silicone-based and purple in color. Oil seals and clutch lines are not designed for DOT 5 brake fluid. Avoid contact between brake fluid and painted parts. Brake fluid attacks paint. Only use clean brake fluid from a sealed container.

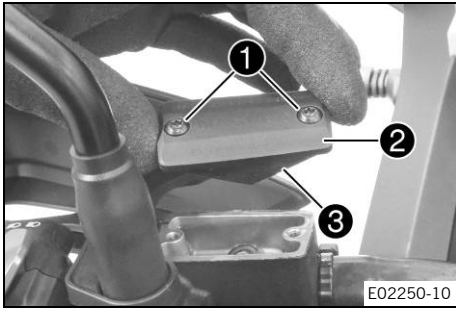

- Move the clutch fluid reservoir mounted on the handlebar to a horizontal position.
- Remove screws ①.
- Remove cover ② with membrane ③.
- Check the fluid level.

Fluid level below container rim	4 mm (0.16 in)
---------------------------------	----------------

- » If the fluid level does not meet specifications:
 - Correct the fluid level of the hydraulic clutch.

Brake fluid DOT 4 / DOT 5.1 (📖 p. 170)
--

- Position the cover with the membrane. Mount and tighten the screws.

i Info
Clean up overflowed or spilled brake fluid immediately with water.



13.11 Checking steering head bearing play



Warning

Danger of accidents Incorrect steering head bearing play impairs the handling characteristic and damages components.

- Correct incorrect steering head bearing play immediately. (Your authorized KTM workshop will be glad to help.)



Info

If the vehicle is operated for a lengthy period with play in the steering head bearing, the bearings and the bearing seats in the frame can become damaged over time.

Preparatory work

- Raise the vehicle with the center stand. (📖 p. 89)

Main work

- Place a load on the rear of the vehicle.
 - ✓ The front wheel is not in contact with the ground.
- Move the handlebar to the straight-ahead position. Move the fork legs back and forth in the direction of travel.

Play should not be detectable on the steering head bearing.

- » If there is detectable play:
 - Adjust steering head bearing play. 🛠️
- Move the handlebar back and forth over the entire steering range.

It must be possible to move the handlebar easily over the entire steering range. There should be no detectable detent positions.
--

- » If detent positions are detected:
 - Adjust steering head bearing play. 🛠️

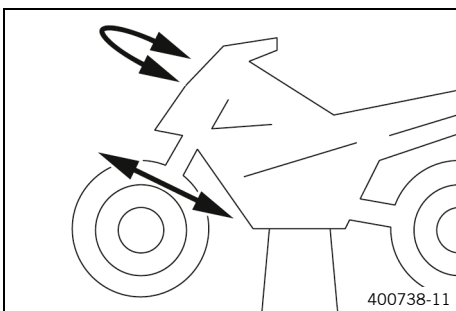

- Check the steering head bearing and adjust if necessary.

Finishing work

- Remove the vehicle from the center stand. (📖 p. 89)

13.12 Removing the bottom triple clamp cover

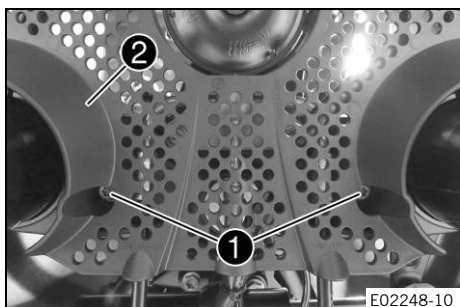

- Remove screws ①.
- Take off the triple clamp cover ② slightly.

13.13 Installing the bottom triple clamp cover

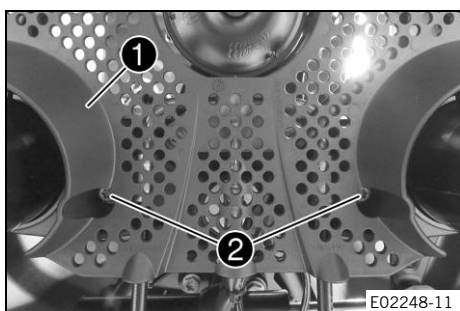

- Position the triple clamp cover ①.
- Mount and tighten screws ②.

Guideline

Remaining screws, chassis	M6	10 Nm (7.4 lbf ft)
---------------------------	----	--------------------

13.14 Removing the windshield

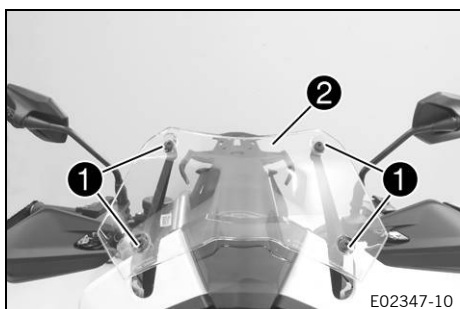

- Remove screws ① with rubber bushing and windshield ②.

13.15 Installing the windshield

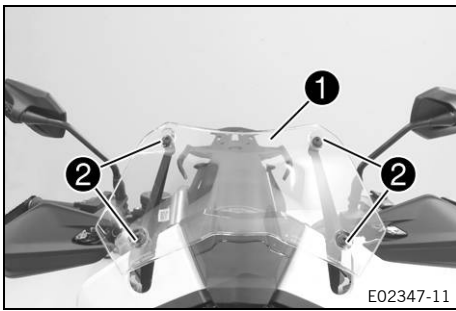

- Position windshield ①.
- Mount and tighten screws ② with the rubber bushings.

Guideline

Screw, windshield	M5x14	3.5 Nm (2.58 lbf ft)
-------------------	-------	-------------------------



13.16 Removing storage compartment

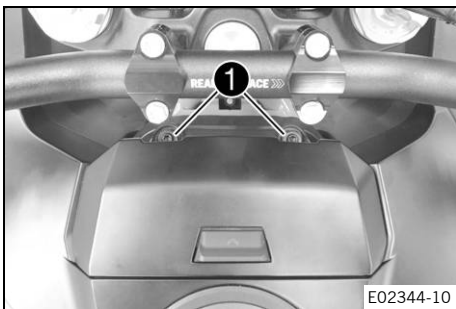

- Remove screws ①.
- Open storage compartment. (📖 p. 25)

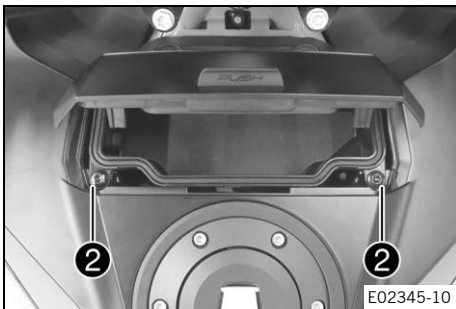

- Remove screws ②.
- Lift storage compartment.

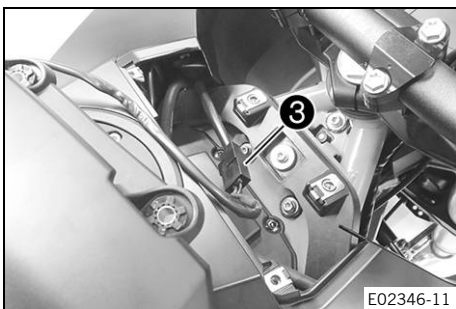

- Disconnect plug-in connector ③ of the USB power outlet.
- Take off storage compartment.



13.17 Installing storage compartment

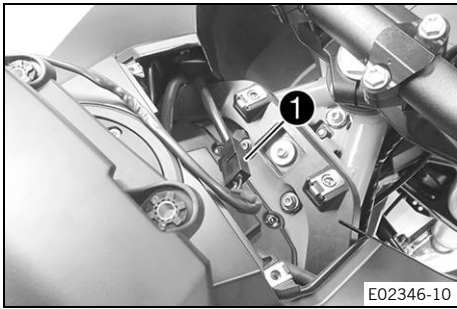

- Join plug-in connector **1** of the USB power outlet.
- Position storage compartment.

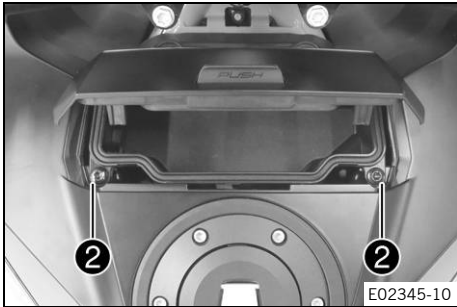

- Mount and tighten screws **2**.

Guideline

Screw, cover part	M5	3.5 Nm (2.58 lbf ft)
-------------------	----	-------------------------

- Close storage compartment. (📖 p. 25)

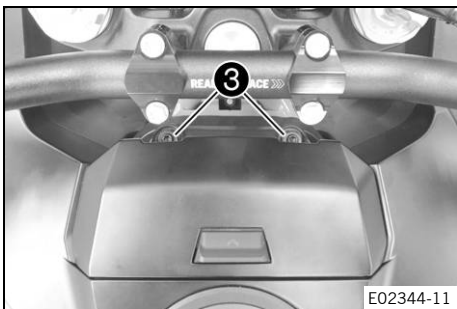

- Mount and tighten screws **3**.

Guideline

Screw, cover part	M6	6 Nm (4.4 lbf ft)
-------------------	----	-------------------

13.18 Removing the top fuel tank fairing

Preparatory work

- Remove the seat. (📖 p. 89)
- Remove the storage compartment. (📖 p. 97)

Main work

- Remove screws **1**.

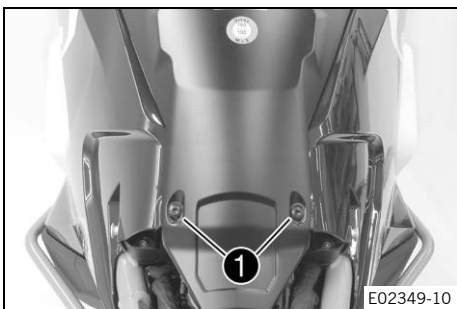



- Detach fuel tank fairing in area **A** and remove in an upwards direction.

13.19 Installing the top fuel tank fairing

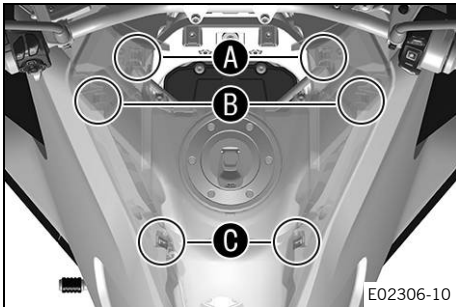

Main work

- Position the fuel tank fairing and hook it in areas **A**, **B** and **C**.
- ✓ The fuel tank fairing engages with an audible click.

Info

Pay attention to the sealing lip and the vent hoses.

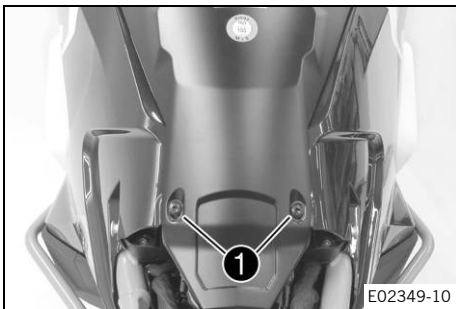

- Mount and tighten screws **1**.

Guideline

Screw, cover part	M5	3.5 Nm (2.58 lbf ft)
-------------------	----	-------------------------

Finishing work

- Install the storage compartment. (🔧 p. 98)
- Mount the seat. (🔧 p. 90)

13.20 Removing the bottom fuel tank fairing

Preparatory work

- Remove the oil plug cover. (🔧 p. 109)
- Remove the front side spoiler. (🔧 p. 101)
- Remove the crash bar. 🛠️ (🔧 p. 110)

Main work

- Remove screws **1**.
- Remove screws **2**.

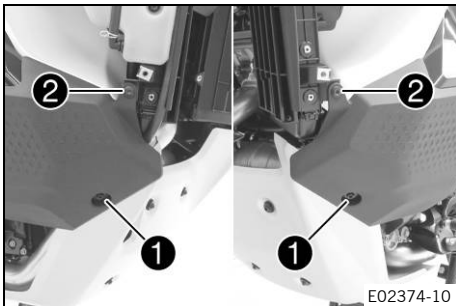

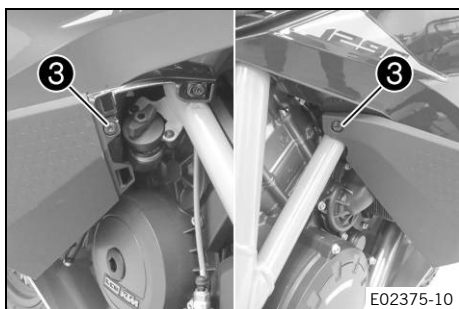

- Remove screws ③.
- Push the lower fuel tank fairings forward and remove.

13.21 Installing the bottom fuel tank fairing

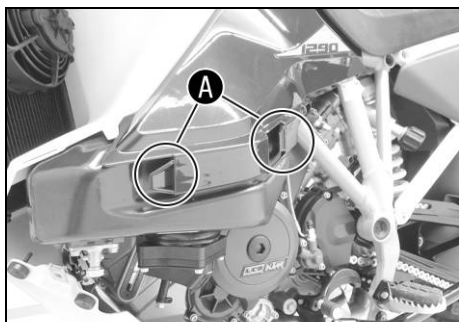

Main work

- Position the left fuel tank fairing and push to the rear.

Guideline

Holding lugs ① of the side cover engage in area A of the left fuel tank fairing.

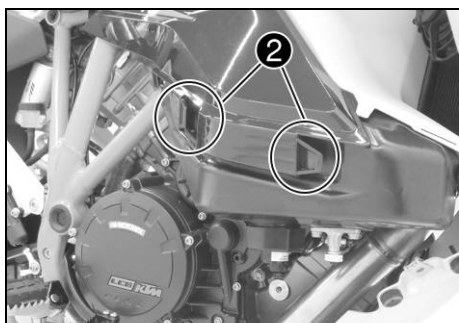
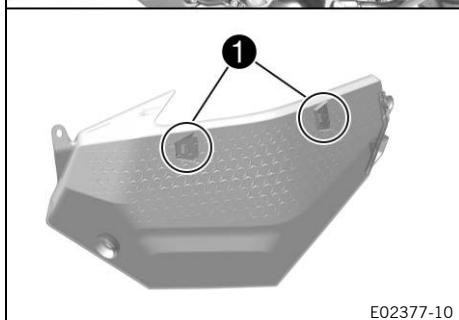

- Position right fuel tank fairing and push to the rear.

Guideline

② the holding lugs of the side cover engage in the area B of the right fuel tank fairing.

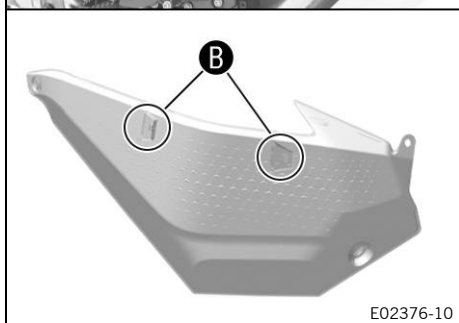

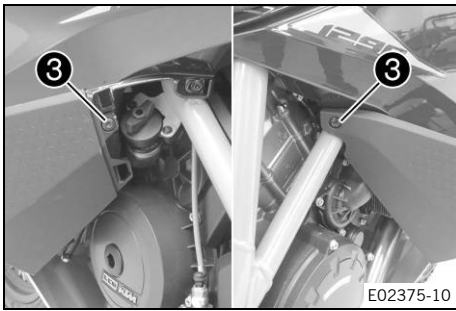

- Mount and tighten screws ③.

Guideline

Screw, cover part	M5	3.5 Nm (2.58 lbf ft)
-------------------	----	-------------------------

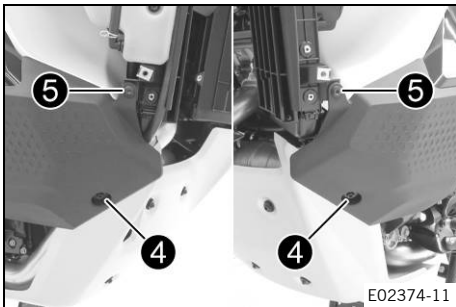

- Mount and tighten screws ④.

Guideline

Screw, engine guard	M6	10 Nm (7.4 lbf ft)
---------------------	----	--------------------

- Mount and tighten screws ⑤.

Guideline

Screw, cover part	M5	3.5 Nm (2.58 lbf ft)
-------------------	----	-------------------------

Finishing work

- Install the oil plug cover. (🔧 p. 109)
- Install the front side spoiler. (🔧 p. 102)
- Install the crash bar. 🛠️ (🔧 p. 111)

13.22 Removing the front side spoiler

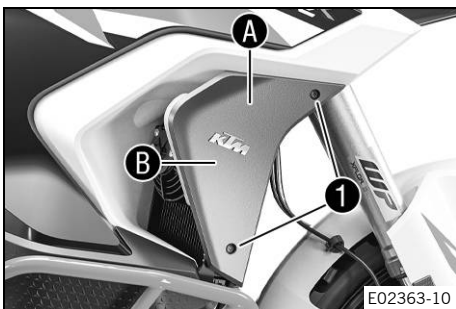

- Remove screws ①.
- Detach the right side spoiler in areas ① and ② and take off.

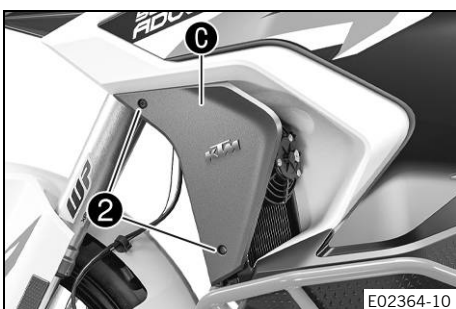

- Remove screws ②.
- Detach and take off the left side spoiler in area ③.

13.23 Installing the front side spoiler

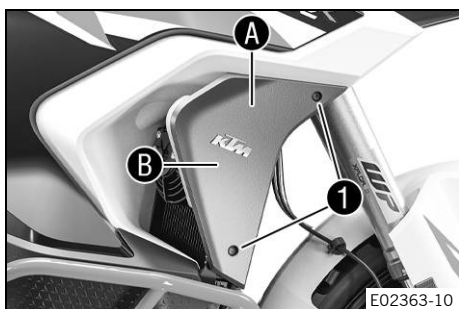

- Position the right side spoiler and attach in area **A** and **B**.
- Mount and tighten screws **1**.

Guideline

Screw, cover part	M5	3.5 Nm (2.58 lbf ft)
-------------------	----	-------------------------

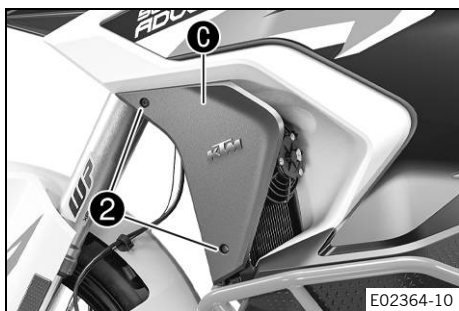

- Position the left side spoiler and attach in area **C**.
- Mount and tighten screws **2**.

Guideline

Screw, cover part	M5	3.5 Nm (2.58 lbf ft)
-------------------	----	-------------------------

13.24 Removing the front side cover

Preparatory work

- Remove the oil plug cover. (📖 p. 109)
- Remove the front side spoiler. (📖 p. 101)
- Remove the crash bar. 🛠️ (📖 p. 110)
- Remove the bottom fuel tank fairing. (📖 p. 99)
- Remove the seat. (📖 p. 89)
- Remove the storage compartment. (📖 p. 97)
- Remove the top fuel tank fairing. (📖 p. 98)

Main work

- Remove screws **1**.
- Remove screw **2** with the bushing.
- Carefully take off the left side fairing from the side.

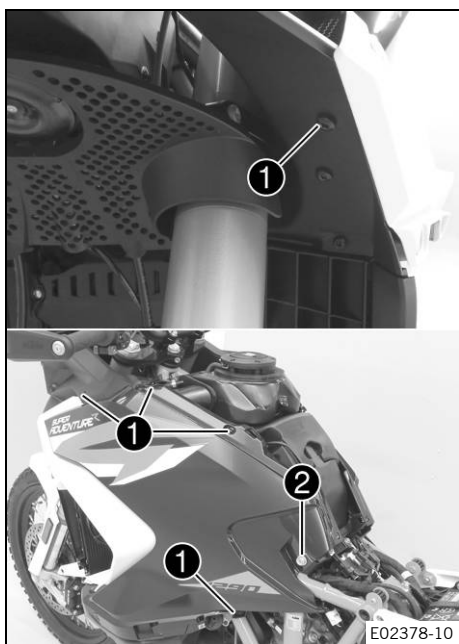

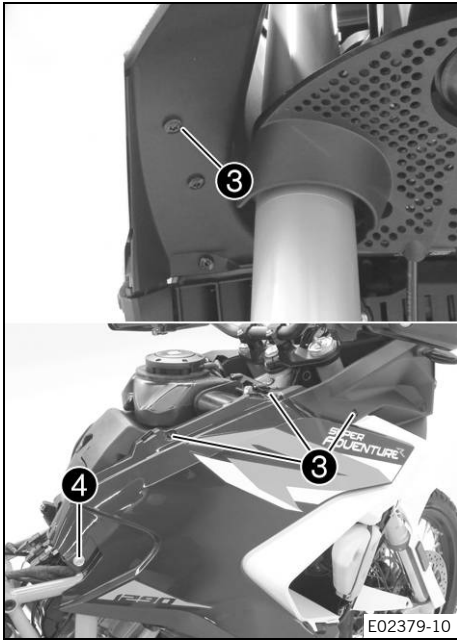

- Remove screws ③.
- Remove screw ④ with the bushing.
- Carefully take off the right side fairing from the side.



13.25 Installing the front side cover ↗

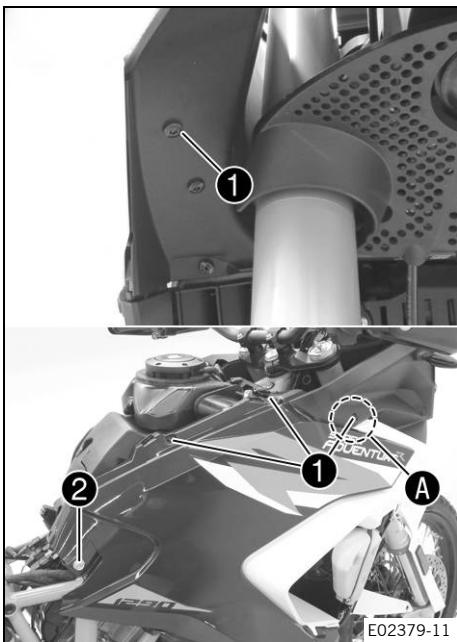

Main work

- Position the right side fairing.

Guideline

The side fairing is located in area **A** under the mask spoiler.

- Mount and tighten screws ①.

Guideline

Screw, cover part	M5	3.5 Nm (2.58 lbf ft)
-------------------	----	-------------------------

- Mount and tighten screw ②.

Guideline

Screw, seat bushing	M6x16	4 Nm (3 lbf ft)
---------------------	-------	-----------------

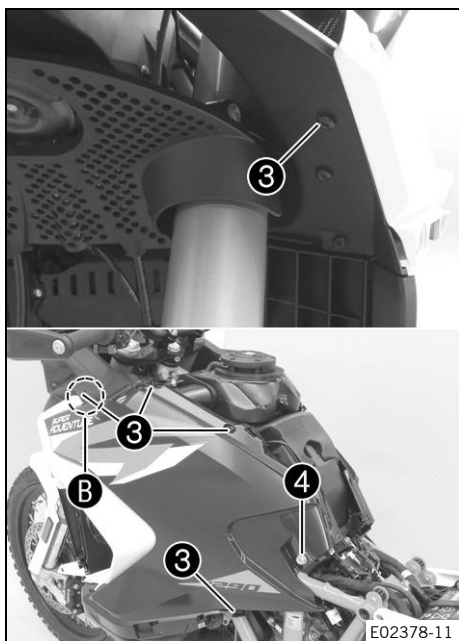

- Position the left side fairing.

Guideline

The side fairing is located in area **B** under the mask spoiler.

- Mount and tighten screws **3**.

Guideline

Screw, cover part	M5	3.5 Nm (2.58 lbf ft)
-------------------	----	-------------------------

- Mount and tighten screw **4**.

Guideline

Screw, seat bushing	M6x16	4 Nm (3 lbf ft)
---------------------	-------	-----------------

Finishing work

- Install the bottom fuel tank fairing. (📖 p. 100)
- Install the oil plug cover. (📖 p. 109)
- Install the front side spoiler. (📖 p. 102)
- Install the crash bar. 🛠️ (📖 p. 111)
- Install the top fuel tank fairing. (📖 p. 99)
- Install the storage compartment. (📖 p. 98)
- Mount the seat. (📖 p. 90)

13.26 Removing the mask spoiler 🛠️

Preparatory work

- Remove the oil plug cover. (📖 p. 109)
- Remove the front side spoiler. (📖 p. 101)
- Remove the crash bar. 🛠️ (📖 p. 110)
- Remove the bottom fuel tank fairing. (📖 p. 99)
- Remove the seat. (📖 p. 89)
- Remove the storage compartment. (📖 p. 97)
- Remove the top fuel tank fairing. (📖 p. 98)
- Remove the front side cover. 🛠️ (📖 p. 102)
- Remove the windshield. (📖 p. 96)

Main work

- Remove cover **1** upwards.

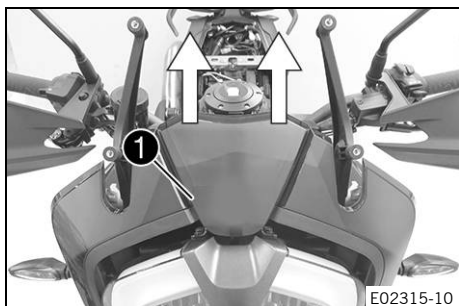

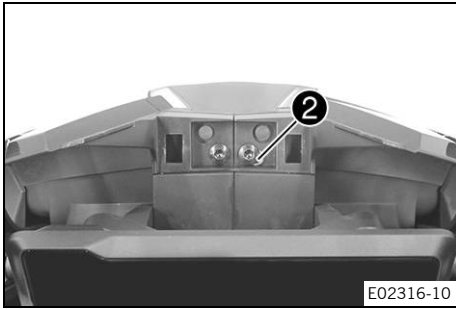

- Remove screw ②.

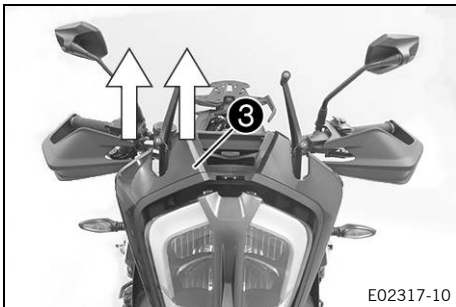

- Pull headlight spoiler ③ upwards to remove.

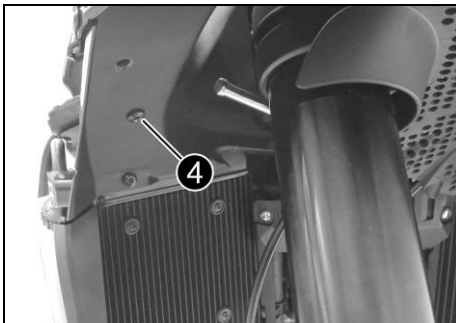

- Remove screws ④.

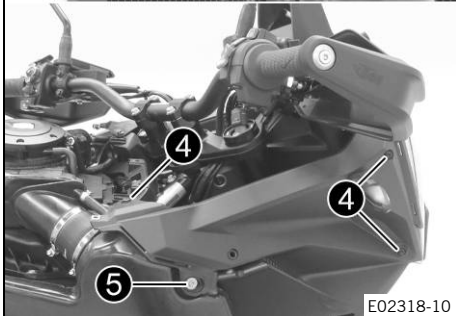

- Remove screw ⑤.

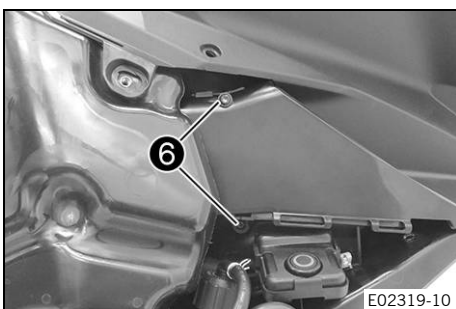

- Remove screws ⑥.

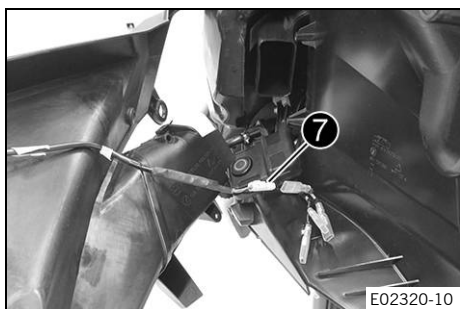

- Pull off the mask spoiler toward the front.
- Disconnect plug-in connection 7 of the turn signal.
- Repeat these steps on the opposite side.

13.27 Installing the mask spoiler

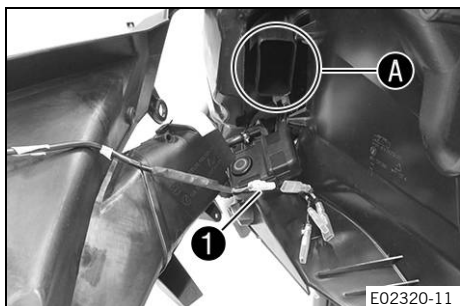

Main work

- Join plug-in connector 1.
- Position the mask spoiler and mount on the intake snorkel in area A.

Info

Ensure that the turn signal cable is placed correctly.

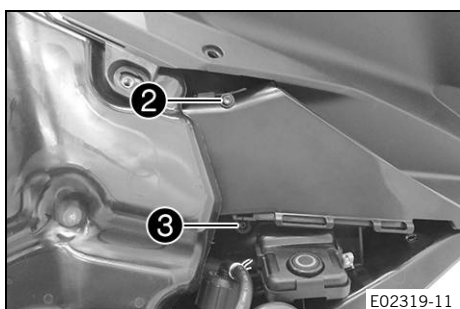

- Mount and tighten screw 2.

Guideline

Remaining screws, chassis	M5	5 Nm (3.7 lbf ft)
---------------------------	----	-------------------

- Mount and tighten screw 3.

Guideline

Remaining screws, chassis	M5	5 Nm (3.7 lbf ft)
---------------------------	----	-------------------



- Mount and tighten screws 4.

Guideline

Screw, cover part	M5	3.5 Nm (2.58 lbf ft)
-------------------	----	-------------------------

- Mount and tighten screw 5.

Guideline

Screw, cover part	M5	3.5 Nm (2.58 lbf ft)
-------------------	----	-------------------------

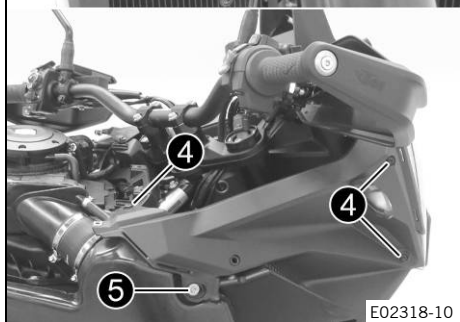

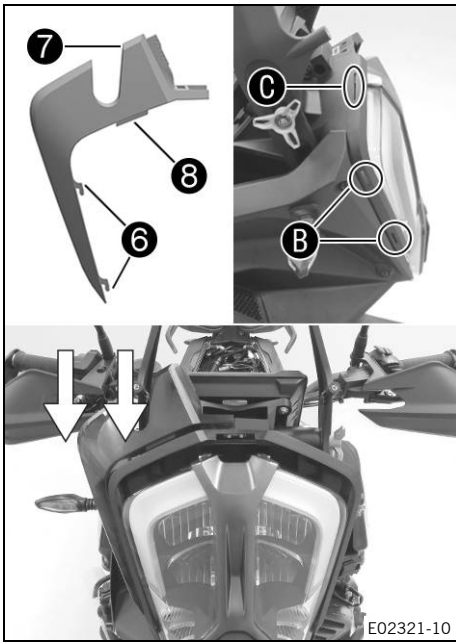

- Attach holding lugs **6** of headlight spoiler **7** in area **B** of the headlight housing and push downward.
- ✓ Holding lug **8** engages in area **C**.

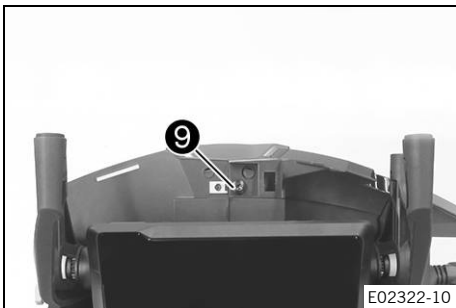

- Mount and tighten screw **9**.

Guideline

Screw, cover part	M5	3.5 Nm (2.58 lbf ft)
-------------------	----	-------------------------

- Repeat these steps on the opposite side.

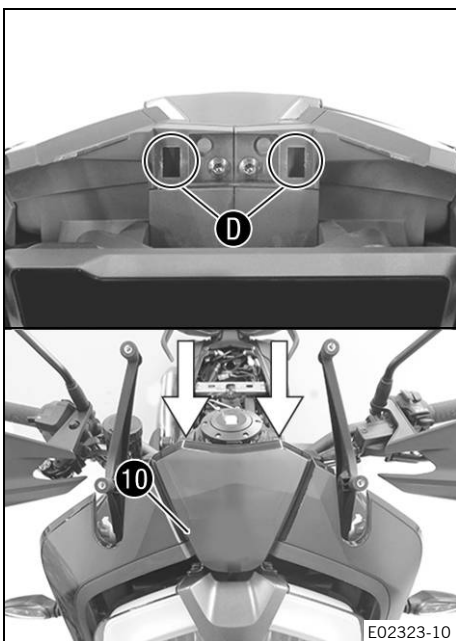

- Mount cover **10** and click into place in the **D** area.
- ✓ The cover engages with an audible click.

Finishing work

- Install the windshield. (📖 p. 97)
- Install the front side cover. 🛠️ (📖 p. 103)
- Install the bottom fuel tank fairing. (📖 p. 100)

- Install the oil plug cover. (📖 p. 109)
- Install the front side spoiler. (📖 p. 102)
- Install the crash bar. 🛠️ (📖 p. 111)
- Install the top fuel tank fairing. (📖 p. 99)
- Install the storage compartment. (📖 p. 98)
- Mount the seat. (📖 p. 90)

13.28 Removing the engine guard

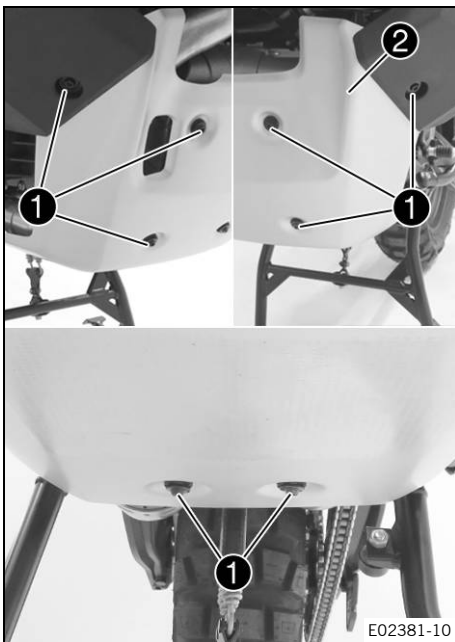

- Remove screws ① with bushings and engine guard ②.

13.29 Installing the engine guard

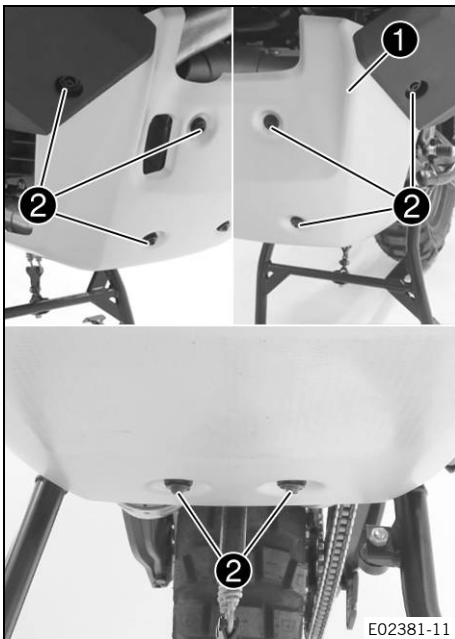

- Position engine guard ①, mount screws ② with bushings and tighten.

Guideline

Screw, engine guard	M6	10 Nm (7.4 lbf ft)
---------------------	----	--------------------

13.30 Removing the oil plug cover

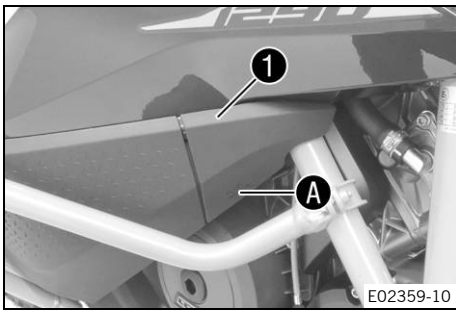

- Pull cover **1** in area **A** back.
- Take off the cover.



13.31 Installing oil plug cover

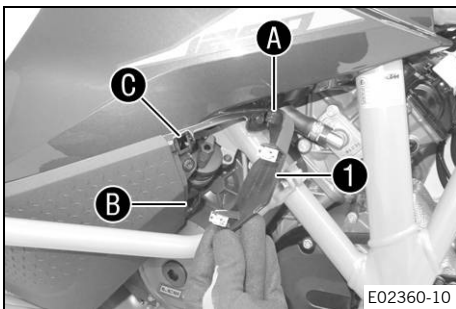

- Hook in cover **1** in area **A**.
- Mount the cover and make sure that it correctly engages in areas **B** and **C**.



13.32 Removing front fender

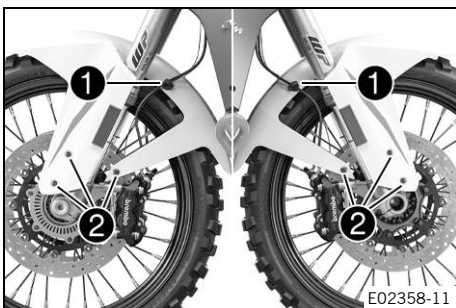

- Open holder **1** and detach the brake lines and cable.
- Remove screws **2**.
- Take the fender off to the front.



Info

Pay attention to the brake lines and the cable.



13.33 Installing front fender

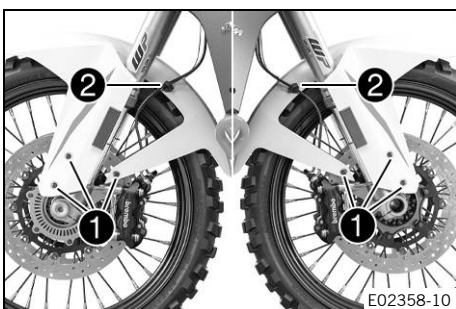

- Position the fender.



Info

Pay attention to the routing of the brake lines and the cable.

- Mount and tighten screws **1**.

Guideline

Screw, fender	M5x12	3.5 Nm (2.58 lbf ft)
---------------	-------	-------------------------

- Insert the brake lines and cable in brackets **2** and close the holder.



13.34 Cleaning the dust boots of the fork legs



Preparatory work

- Raise the vehicle with the center stand. (📖 p. 89)
- Remove front fender. (📖 p. 109)

Main work

- Push dust boots ❶ of both fork legs downward.

Info

The dust boots remove dust and coarse dirt particles from the inside fork tubes. Over time, dirt can accumulate behind the dust boots. If this dirt is not removed, the oil seals behind can start to leak.



Warning

Danger of accidents Oil or grease on the brake discs reduces the braking effect.

- Always keep the brake discs free of oil and grease.
- Clean the brake discs with brake cleaner when necessary.

- Clean and oil the dust boots and inner fork tubes of both fork legs.

Universal oil spray (📖 p. 172)

- Press dust boots ❶ back into their installation position.
- Remove excess oil.

Finishing work

- Install front fender. (📖 p. 109)
- Remove the vehicle from the center stand. (📖 p. 89)

13.35 Removing the crash bar



- Remove fittings ❶.

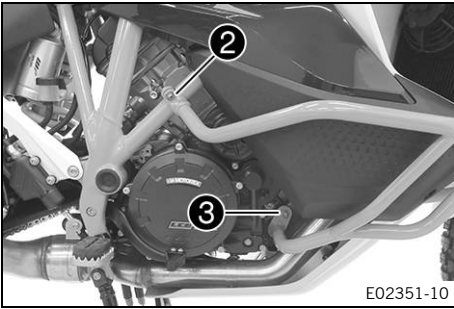

- Remove screw ② and open the clamps.
- Remove screw ③.
- Take off the right crash bar.

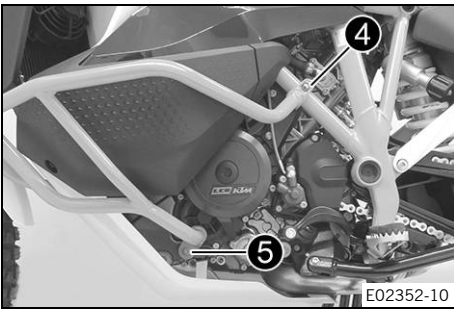

- Remove screw ④ and open the clamps.
- Remove screw ⑤.
- Take off the left crash bar.

13.36 Installing the crash bar ↗

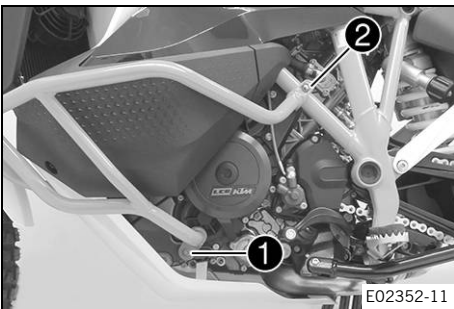

- Position the left crash bar with the frame protector.

i Info
Cover the components to protect them against damage.

- Mount screw ①, but do not tighten yet.

Guideline

Remaining screws, chassis	M8	25 Nm (18.4 lbf ft)
---------------------------	----	---------------------

- Position clamps and mount screw ②, but do not tighten yet.

Guideline

Remaining screws, chassis	M6	10 Nm (7.4 lbf ft)
---------------------------	----	--------------------

- Position the right crash bar with the frame protector.

i Info
Cover the components to protect them against damage.

- Mount screw ③, but do not tighten yet.

Guideline

Remaining screws, chassis	M8	25 Nm (18.4 lbf ft)
---------------------------	----	---------------------

- Position clamps and mount screw ④, but do not tighten yet.

Guideline

Remaining screws, chassis	M6	10 Nm (7.4 lbf ft)
---------------------------	----	--------------------

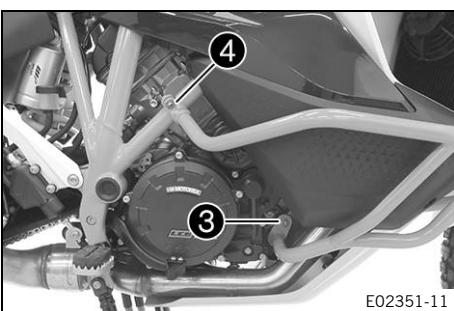

13 SERVICE WORK ON THE CHASSIS



- Mount and tighten fittings **5**.

Guideline

Remaining screws, chassis	M6	10 Nm (7.4 lbf ft)
---------------------------	----	--------------------

- ✓ The crash bars are equally aligned with each other.

- Tighten all the screws of the crash bar.

Guideline

Remaining screws, chassis	M6	10 Nm (7.4 lbf ft)
Remaining screws, chassis	M8	25 Nm (18.4 lbf ft)

14.1 Anti-lock braking system (ABS)

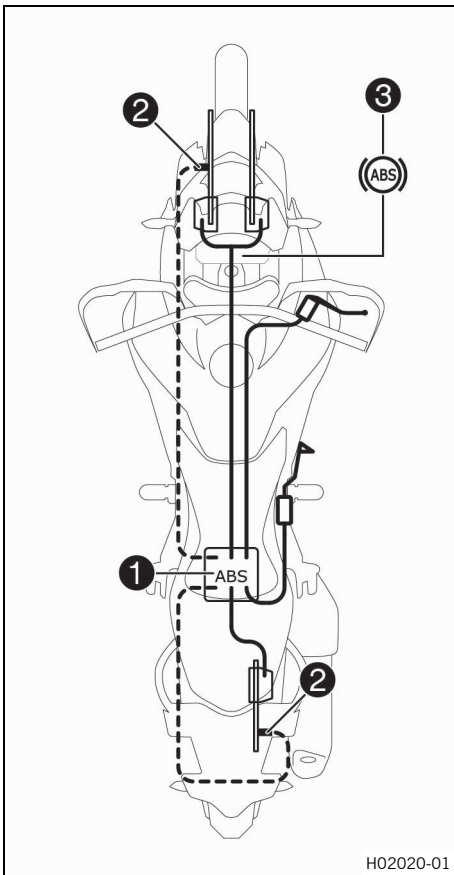

The ABS module ①, consisting of a hydraulic unit, an ABS control unit, and a return pump, is located under the seat. One wheel speed sensor ② is located in each case on the front and the rear wheel.

**Warning**

Danger of accidents Changes to the vehicle impair the function of the ABS.

- Do not make any changes to the suspension travel.
- Only use spare parts on the brake system which have been approved and recommended by KTM.
- Only use tires/wheels approved by KTM with the corresponding speed index.
- Maintain the specified tire pressure.
- Ensure that service work and repairs are performed professionally. (Your authorized KTM workshop will be glad to help.)

ABS is a safety system that prevents locking of the wheels when driving straight ahead without the influence of lateral forces.

**Warning**

Danger of accidents Driving aids can reduce the probability of a fall only within physical limits.

It is not always possible to compensate for extreme riding situations, for example with luggage loaded with a high center of gravity, varying road surfaces, steep descents or full braking without disengaging the gear.

- Adapt your riding style to the road conditions and your driving ability.

**Warning**

Danger of accidents An incorrectly selected ABS mode makes control of the vehicle considerably more difficult.

The ABS modes are each only suitable for certain conditions.

- Always select an ABS mode that is compatible with the surface of the ground.

ABS has two operating modes: the **Road** and **Offroad** ABS modes. In the **Road** ABS mode, the brakes are also applied to the rear wheel when the front brake is applied. ABS regulates both wheels. In the **Offroad** ABS mode, the front brake slows the front wheel. The rear brake slows the rear wheel. There is no ABS control on the rear wheel. The ABS warning lamp ③ flashes slowly to remind you that the **Offroad** ABS mode is enabled.

i **Info**

In ABS mode **Offroad**, the ABS regulates the front wheel later and the rear wheel can lock, resulting in a risk of falling.

The ABS operates with two independent brake circuits (front and rear brakes). When the ABS control unit detects a locking tendency in a wheel, ABS begins regulating the brake pressure. The control function causes a slight pulsing of the hand and foot brake levers.

The ABS warning lamp **3** must light up after the ignition is switched on and go out after starting off. If it does not go out after starting off or if it lights up while riding, this indicates a malfunction in the ABS. In this case, the ABS is no longer enabled and the wheels may lock during braking. The brake system itself stays functional; only ABS control is not available.

The ABS warning lamp may also light up if the rotating speeds of the front and rear wheels differ greatly under extreme riding conditions, for example when making "wheelies" or if the rear wheel spins. This causes the ABS to switch off.

To reactivate the ABS, stop the vehicle and switch off the ignition. The ABS is reactivated when the vehicle is switched on again. The ABS warning lamp goes out after starting off.

MSC

The **MSC** is a supplementary function for the ABS that can prevent the wheels locking and slipping during braking when the vehicle is inclined (when cornering) within physical possibilities.

Using the 6-D sensor, the ABS control is now dependent on the inclination and pitch angle.

ABS control that is dependent on the inclination and pitch angle improves the riding stability and braking effect in all riding situations. The **MSC** also reduces the righting moment during hard braking in curves. This prevents the motorcycle from righting itself from an inclined angle and moving along a larger curve radius.

Due to the additional electronic control of the brake force distribution between the two wheels, the braking force is optimally distributed and the motorcycle is additionally stabilized.

i **Info**

The **MSC** is only active in **Road** ABS mode.

14.2 Checking the brake discs

**Warning**

Danger of accidents Worn-out brake discs reduce the braking effect.

- Make sure that worn-out brake discs are replaced immediately. (Your authorized KTM workshop will be glad to help.)
-

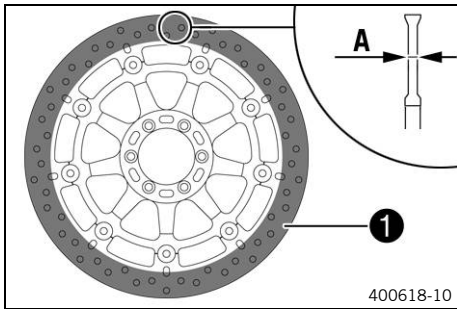

- Check the front and rear brake disc thickness at multiple points for the dimension **A**.

i Info
Wear will reduce the thickness of the brake disc at contact surface **1** of the brake linings.

Brake discs - wear limit	
front	4 mm (0.16 in)
rear	4.5 mm (0.177 in)

- » If the brake disc thickness is less than the specified value.
 - Change the front brake discs. 🛠️
 - Change the rear brake disc. 🛠️
- Check the front and rear brake discs for damage, cracking, and deformation.
 - » If the brake disc exhibits damage, cracking, or deformation:
 - Change the front brake discs. 🛠️
 - Change the rear brake disc. 🛠️

14.3 Checking the front brake fluid level



Warning

Danger of accidents An insufficient brake fluid level will cause the brake system to fail.

If the brake fluid level drops below the **MIN** marking, the brake system is leaking or the brake linings are worn down.

- Check the brake system and do not continue riding until the problem is eliminated. (Your authorized KTM workshop will be glad to help.)



Warning

Danger of accidents Old brake fluid reduces the braking effect.

- Make sure that brake fluid for the front and rear brake is changed in accordance with the service schedule. (Your authorized KTM workshop will be glad to help.)

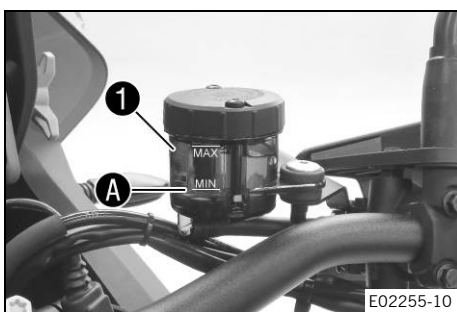

- Move the brake reservoir mounted on the handlebar to a horizontal position.
- Check the brake fluid level in brake fluid reservoir **1**.
 - » If the brake fluid level has dropped below **MIN** marking **A**:
 - Add front brake fluid. 🛠️ (📖 p. 116)

14.4 Adding front brake fluid ↴



Warning

Danger of accidents An insufficient brake fluid level will cause the brake system to fail.

If the brake fluid level drops below the **MIN** marking, the brake system is leaking or the brake linings are worn down.

- Check the brake system and do not continue riding until the problem is eliminated. (Your authorized KTM workshop will be glad to help.)



Warning

Skin irritation Brake fluid causes skin irritation.

- Keep brake fluid out of the reach of children.
- Wear suitable protective clothing and safety glasses.
- Do not allow brake fluid to come into contact with the skin, the eyes or clothing.
- Consult a doctor immediately if brake fluid has been swallowed.
- Rinse the affected area with plenty of water in the event of contact with the skin.
- Rinse eyes thoroughly with water immediately and consult a doctor if brake fluid comes into contact with the eyes.
- If brake fluid spills on to your clothing, change the clothing.



Warning

Danger of accidents Old brake fluid reduces the braking effect.

- Make sure that brake fluid for the front and rear brake is changed in accordance with the service schedule. (Your authorized KTM workshop will be glad to help.)



Note

Environmental hazard Hazardous substances cause environmental damage.

- Dispose of oils, grease, filters, fuel, cleaning agents, brake fluid, etc., correctly and in compliance with the applicable regulations.



Info

Never use DOT 5 brake fluid. It is silicone-based and purple in color. Oil seals and brake lines are not designed for DOT 5 brake fluid.

Avoid contact between brake fluid and painted parts. Brake fluid corrodes paint.

Only use clean brake fluid from a sealed container.

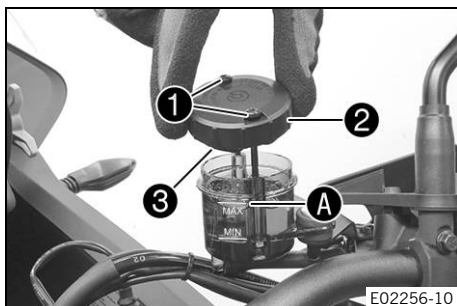

Preparatory work

- Check the front brake linings. (📖 p. 117)

Main work

- Move the brake fluid reservoir mounted on the handlebar to a horizontal position.
- Remove screws ❶.
- Take off cover ❷ with membrane ❸.
- Add brake fluid up to the **MAX** marking A.

Brake fluid DOT 4 / DOT 5.1 (📖 p. 170)

- Position cover ❷ with membrane ❸.
- Mount and tighten screws ❶.

Guideline

Screw, front brake reservoir cover		1 Nm (0.7 lbf ft)
------------------------------------	--	-------------------

i Info
Use water to immediately clean up any brake fluid that has overflowed or spilled.



14.5 Checking the front brake linings

Warning
Danger of accidents Worn-out brake linings reduce the braking effect.
– Ensure that worn-out brake linings are replaced immediately. (Your authorized KTM workshop will be glad to help.)

Warning
Danger of accidents Damaged brake discs reduce the braking effect.
If the brake linings are not changed in time, the brake lining carriers grind against the brake disc. As a consequence, the braking effect is greatly reduced and the brake discs are destroyed.
– Check the brake linings regularly.

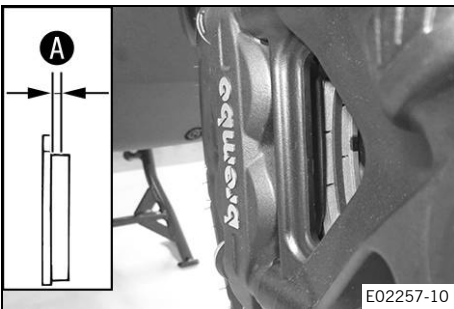

– Check all brake linings on both brake calipers to ensure they have the minimum thickness **A**.

Minimum thickness A	$\geq 1 \text{ mm } (\geq 0.04 \text{ in})$
----------------------------	---

- » If the minimum thickness is less than specified:
 - Change the front brake linings. 🛠️
- Check all brake linings on both brake calipers for damage and cracking.
 - » If there is damage or cracking:
 - Change the front brake linings. 🛠️



14.6 Checking the rear brake fluid level

Warning
Danger of accidents An insufficient brake fluid level will cause the brake system to fail.
If the brake fluid level drops below the **MIN** marking, the brake system is leaking or the brake linings are worn down.
– Check the brake system and do not continue riding until the problem is eliminated. (Your authorized KTM workshop will be glad to help.)

Warning
Danger of accidents Old brake fluid reduces the braking effect.
– Make sure that brake fluid for the front and rear brake is changed in accordance with the service schedule. (Your authorized KTM workshop will be glad to help.)

Preparatory work

- Raise the vehicle with the center stand. (📖 p. 89)

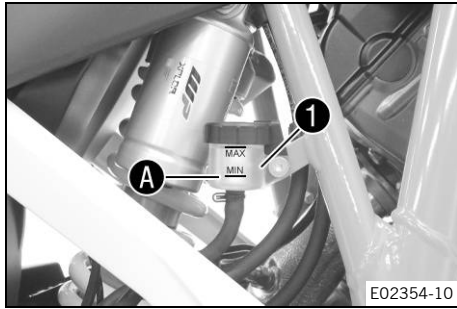

Main work

- Check the brake fluid level in brake fluid reservoir ①.
 - » If the fluid level reaches the **MIN** marking A:
 - Add rear brake fluid. 🛠️ (📖 p. 118)

14.7 Adding rear brake fluid 🛠️



Warning

Danger of accidents An insufficient brake fluid level will cause the brake system to fail.

If the brake fluid level drops below the **MIN** marking, the brake system is leaking or the brake linings are worn down.

- Check the brake system and do not continue riding until the problem is eliminated. (Your authorized KTM workshop will be glad to help.)



Warning

Skin irritation Brake fluid causes skin irritation.

- Keep brake fluid out of the reach of children.
- Wear suitable protective clothing and safety glasses.
- Do not allow brake fluid to come into contact with the skin, the eyes or clothing.
- Consult a doctor immediately if brake fluid has been swallowed.
- Rinse the affected area with plenty of water in the event of contact with the skin.
- Rinse eyes thoroughly with water immediately and consult a doctor if brake fluid comes into contact with the eyes.
- If brake fluid spills on to your clothing, change the clothing.



Warning

Danger of accidents Old brake fluid reduces the braking effect.

- Make sure that brake fluid for the front and rear brake is changed in accordance with the service schedule. (Your authorized KTM workshop will be glad to help.)



Note

Environmental hazard Hazardous substances cause environmental damage.

- Dispose of oils, grease, filters, fuel, cleaning agents, brake fluid, etc., correctly and in compliance with the applicable regulations.



Info

Never use DOT 5 brake fluid. It is silicone-based and purple in color. Oil seals and brake lines are not designed for DOT 5 brake fluid.

Avoid contact between brake fluid and painted parts. Brake fluid corrodes paint.

Only use clean brake fluid from a sealed container.

Preparatory work

- Raise the vehicle with the center stand. (📖 p. 89)
- Check the rear brake linings. (📖 p. 119)

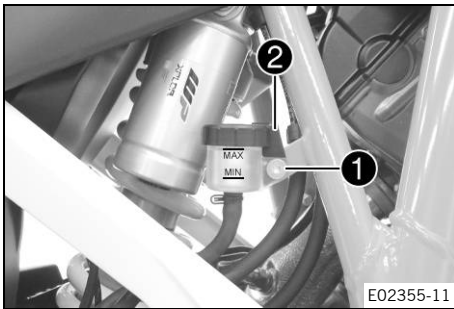

Main work

- Remove screw ① with lock washer ②.
- Hold the brake reservoir vertically.

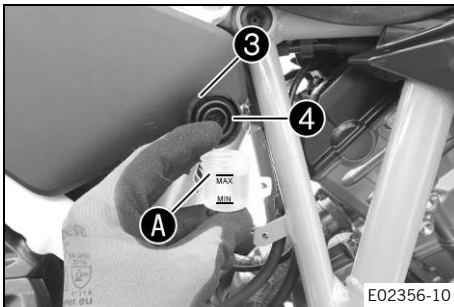

- Remove screw cap ③ with diaphragm ④.
- Add brake fluid up to the **MAX** marking **A**.

Brake fluid DOT 4 / DOT 5.1 (📖 p. 170)

- Mount and tighten screw cap ③ with membrane ④.

Guideline

Cover, brake reservoir, rear		3.5 Nm (2.58 lbf ft)
------------------------------	--	-------------------------



Info

Use water to immediately clean up any brake fluid that has overflowed or spilled.

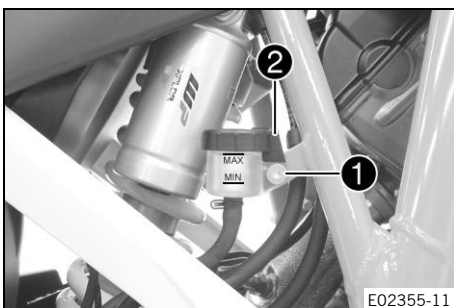

- Position the brake reservoir with the lock washer ②.
- Tighten screw ①.

Guideline

Screw, brake reservoir, rear brake	M5	3.5 Nm (2.58 lbf ft) Loctite®243™
------------------------------------	----	---

14.8 Checking the rear brake linings



Warning

Danger of accidents Worn-out brake linings reduce the braking effect.

- Ensure that worn-out brake linings are replaced immediately. (Your authorized KTM workshop will be glad to help.)



Warning

Danger of accidents Damaged brake discs reduce the braking effect.

If the brake linings are not changed in time, the brake lining carriers grind against the brake disc. As a consequence, the braking effect is greatly reduced and the brake discs are destroyed.

- Check the brake linings regularly.

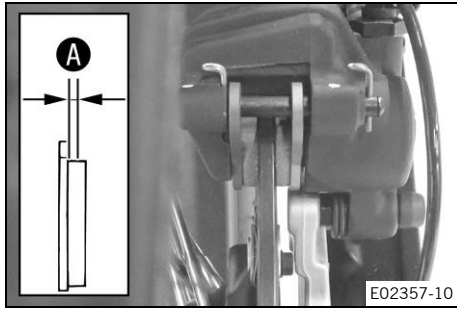

- Check the brake linings for minimum thickness **A**.

Minimum thickness A	$\geq 1 \text{ mm } (\geq 0.04 \text{ in})$
----------------------------	---

- » If the minimum thickness is less than specified:
 - Change the rear brake linings. ↘
- Check the brake linings for damage and cracking.
 - » If there is wear or tearing:
 - Change the rear brake linings. ↘

15.1 Removing the front wheel ↩

Preparatory work

- Raise the vehicle with the center stand. (📖 p. 89)

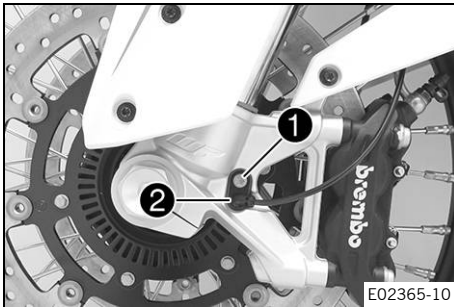

Main work

- Place a load on the rear of the vehicle.
- ✓ The front wheel is not in contact with the ground.
- Remove screw ① and pull wheel speed sensor ② out of the hole.

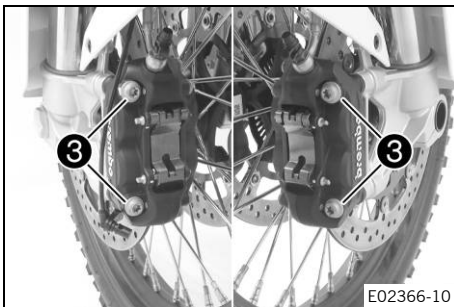

- Remove screws ③ from both brake calipers.
- Press back the brake linings by slightly tilting the brake calipers laterally on the brake disc.
- Pull the brake calipers carefully back from the brake discs and hang to the side loosely.



Info

Do not operate the hand brake lever if the brake calipers have been removed.

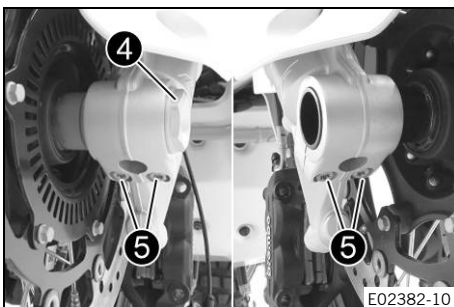

- Loosen screw ④ by several rotations.
- Loosen screws ⑤.
- Press on screw ④ to push the wheel spindle out of the axle clamp.
- Remove screw ④.



Warning

Danger of accidents Damaged brake discs reduce the braking effect.

- Always lay the wheel down in such a way that the brake discs are not damaged.

- Hold the front wheel and remove the wheel spindle. Take the front wheel out of the fork.



Info

Do not actuate the hand brake lever when the front wheel is removed.

- Remove spacers ⑥.

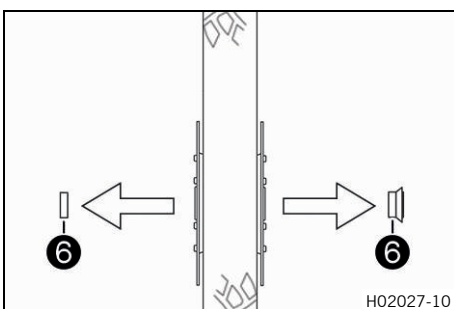

15.2 Installing the front wheel ↩



Warning

Danger of accidents Oil or grease on the brake discs reduces the braking effect.

- Always keep the brake discs free of oil and grease.
- Clean the brake discs with brake cleaner when necessary.

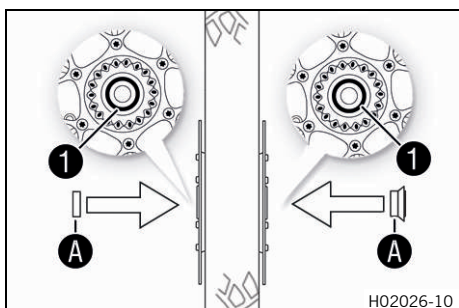

- Check the wheel bearing for damage and wear.
 - » If the wheel bearing is damaged or worn:
 - Change front wheel bearing. ↩
- Clean and grease shaft seal rings ① and contact surfaces ①A of the spacers.

Long-life grease (📖 p. 172)

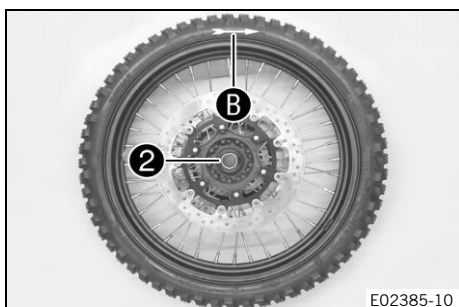

- Insert narrow spacer ② on the right in the direction of travel.



Info

Arrow ①B indicates the direction of travel of the front wheel.
The wheel speed sensor wheel is on the left viewed in the direction of travel.

- Insert the wide spacer on the left in the direction of travel.

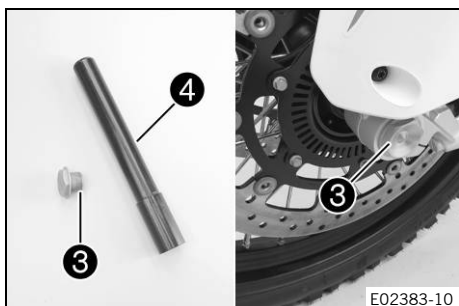

Warning

Danger of accidents Oil or grease on the brake discs reduces the braking effect.

- Always keep the brake discs free of oil and grease.
- Clean the brake discs with brake cleaner when necessary.

- Clean and grease screw ③ and wheel spindle ④.

Long-life grease (📖 p. 172)

- Jack up the front wheel into the fork, position it, and insert the wheel spindle.
- Mount and tighten screw ③.

Guideline

Screw, front wheel spindle	M25x1.5	45 Nm (33.2 lbf ft) Thread greased
----------------------------	---------	---------------------------------------

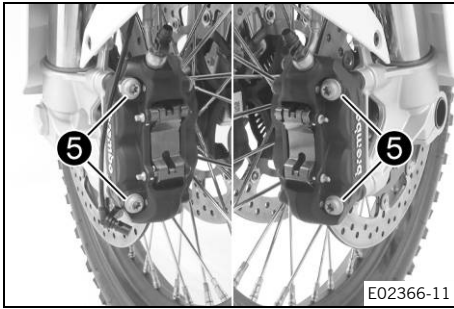

- Position brake calipers.
 - ✓ The brake linings are correctly positioned.
- Mount screws 5 on both brake calipers, but do not tighten yet.
- Operate the hand brake lever repeatedly until the brake linings are in contact with the brake disc and there is a pressure point. Secure the hand brake lever in the activated position.
 - ✓ The brake calipers straighten.
- Tighten screws 5 on both brake calipers.

Guideline

Screw, front brake caliper	M10x1.5x55	45 Nm (33.2 lbf ft) Loctite®243™
----------------------------	------------	--

- Remove locking piece of the hand brake lever.
- Position wheel speed sensor 6 in the hole.
- Mount and tighten screw 7.

Guideline

Remaining screws, chassis	M6	10 Nm (7.4 lbf ft)
---------------------------	----	--------------------

- Remove the vehicle from the center stand. (📖 p. 89)

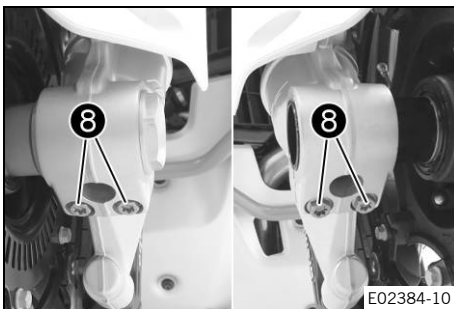
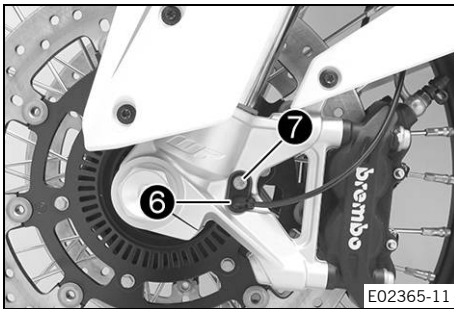

- Operate the front brake and compress the fork a few times firmly.
 - ✓ The fork legs straighten.
- Tighten screws 8.

Guideline

Screw, fork shoe	M8x20	15 Nm (11.1 lbf ft)
------------------	-------	---------------------

15.3 Removing the rear wheel ↩

Preparatory work

- Raise the vehicle with the center stand. (📖 p. 89)

Main work

- Manually press the brake caliper toward the brake disc to push back the brake pistons.

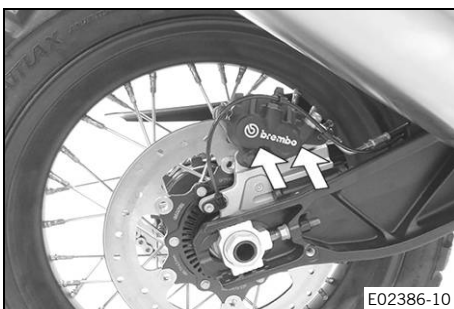

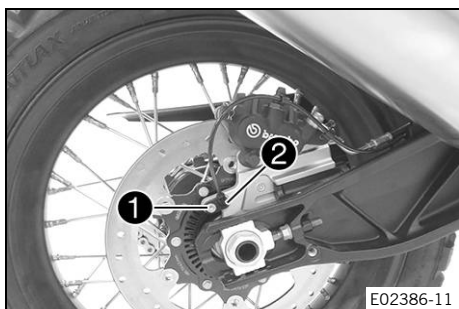

- Remove screw **1** and pull wheel speed sensor **2** out of the hole.

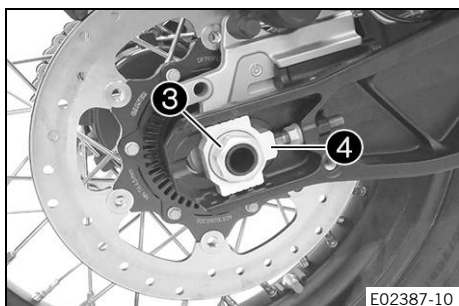

- Remove nut **3**. Take off chain adjuster **4**.

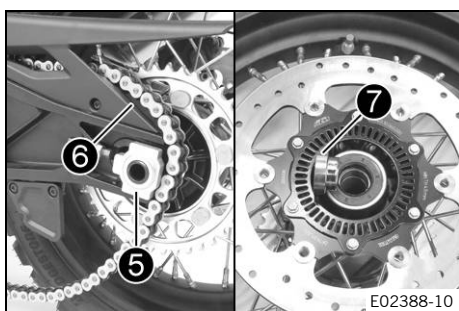

- Pull out wheel spindle **5** far enough to allow the rear wheel to be pushed forward.
- Push the rear wheel forward as far as possible. Take the chain off the rear sprocket and place it on chain sprocket guard **6**.



Warning

Danger of accidents Damaged brake discs reduce the braking effect.

- Always lay the wheel down in such a way that the brake disc is not damaged.

- Hold the rear wheel and remove the wheel spindle. Take the rear wheel out of the link fork.



Info

Do not operate the foot brake when the rear wheel is removed.

- Remove spacer **7**.

15.4 Installing the rear wheel ↗



Warning

Danger of accidents Oil or grease on the brake discs reduces the braking effect.

- Always keep the brake discs free of oil and grease.
- Clean the brake discs with brake cleaner when necessary.



Warning

Danger of accidents There is no braking effect to start with at the rear brake after installing the rear wheel.

- Actuate the foot brake several times before going on a ride until you can feel a firm pressure point.

Main work

- Check the rear hub damping rubber pieces. 🛠️ (📖 p. 126)
- Check the wheel bearing for damage and wear.
 - » If the wheel bearing is damaged or worn:
 - Change the rear wheel bearing. 🛠️
- Clean and grease shaft seal ring ① and contact surface A of the spacer.

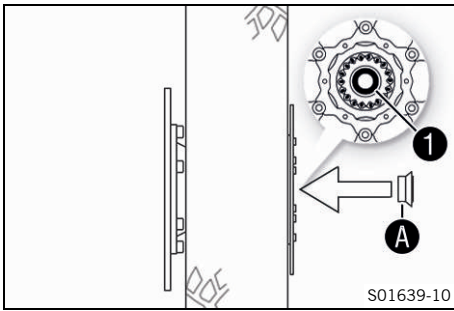

Long-life grease (📖 p. 172)

- Insert a spacer.
- Clean and grease the thread of the wheel spindle and nut.

Long-life grease (📖 p. 172)
- Mount the damping rubber pieces and rear sprocket carrier on the rear wheel.
- Place the rear wheel in the link fork and engage the brake disc in the brake caliper.

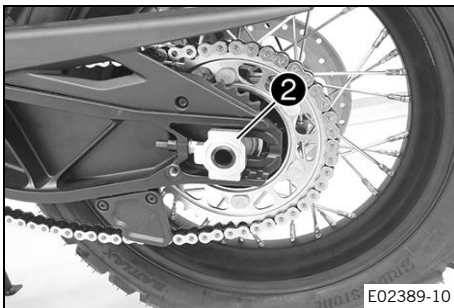

- Mount wheel spindle ②, but do not push it in all the way.
- Push the rear wheel forward as far as possible and lay the chain on the rear sprocket.

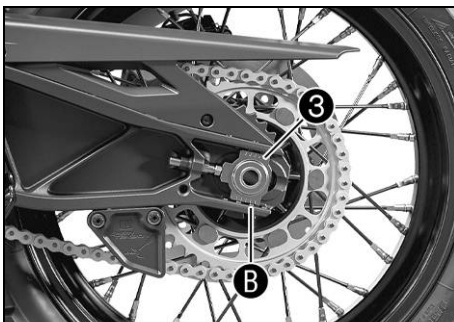

- Push wheel spindle in all the way and mount chain adjuster ④ and nut ⑤.

i Info

Mount chain adjusters ③ and ④ in the same position.

- Make sure that the chain adjusters are fitted correctly on the adjusting screws.

Guideline

In order for the rear wheel to be correctly aligned, the markings on the left and right chain adjusters must be in the same position relative to reference markings B.

- Tighten nut ⑤.

Guideline

Nut, rear wheel spindle	M25x1.5	90 Nm (66.4 lbf ft) Thread greased
-------------------------	---------	---------------------------------------

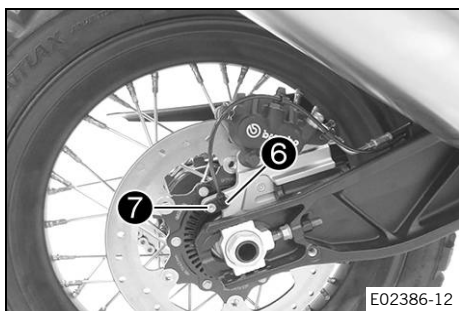

- Position wheel speed sensor **6** in the hole.
- Mount and tighten screw **7**.

Guideline

Remaining screws, chassis	M6	10 Nm (7.4 lbf ft)
---------------------------	----	--------------------

- Operate the foot brake lever repeatedly until the brake linings are in contact with the brake disc and there is a pressure point.

Finishing work

- Check the chain tension. (📖 p. 91)
- Remove the vehicle from the center stand. (📖 p. 89)

15.5 Checking the rear hub damping rubber pieces 🛠️

i Info

The engine power is transmitted from the rear sprocket to the rear wheel via the 6 damping rubber pieces. The damping rubber pieces wear out during operation. If the damping rubber pieces are not changed in time, the rear sprocket carrier and the rear hub will be damaged.

Preparatory work

- Raise the vehicle with the center stand. (📖 p. 89)
- Remove the rear wheel. 🛠️ (📖 p. 123)



Main work

- Check the damping rubber pieces **1** of the rear hub for damage and wear.
 - » If the damping rubber pieces of the rear hub are damaged or worn:
 - Change all the damping rubber pieces of the rear hub. 🛠️

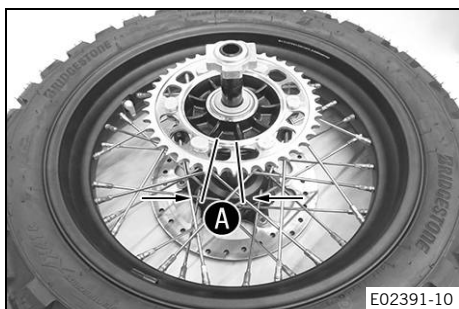

- Lay the rear wheel on a workbench with the rear sprocket facing upward and insert the wheel spindle in the hub.
- Check the rear sprocket play **A**.

i Info

Measure the play on the outside of the rear sprocket.

Play of damping rubber pieces on rear wheel	≤ 5 mm (≤ 0.2 in)
---	-------------------

- » If clearance **A** is larger than the specified value:
 - Change all the damping rubber pieces of the rear hub. 🛠️

Finishing work

- Install the rear wheel. 🛠️ (📖 p. 124)
- Check the chain tension. (📖 p. 91)
- Remove the vehicle from the center stand. (📖 p. 89)

15.6 Checking the tire condition



Warning

Danger of accidents If a tire bursts while riding, the vehicle becomes uncontrollable.

- Ensure that damaged or worn tires are replaced immediately. (Your authorized KTM workshop will be glad to help.)



Warning

Danger of crashing Different tire tread patterns on the front and rear wheel impair the handling characteristic.

Different tire tread patterns can make the vehicle significantly more difficult to control.

- Make sure that only tires with a similar tire tread pattern are fitted to the front and rear wheel.



Warning

Danger of accidents Non-approved or non-recommended tires and wheels impact the handling characteristic.

- Only use tires/wheels approved by KTM with the corresponding speed index.



Warning

Danger of accidents New tires have reduced road grip.

The contact surface on new tires is not yet roughened.

- Run in new tires with moderate riding at alternating angles.
Running-in phase 200 km (124 mi)



Info

Tire type, tire condition, and tire pressure influence the braking and handling characteristics of the vehicle.

Worn tires are particularly unfavorable on wet surfaces.

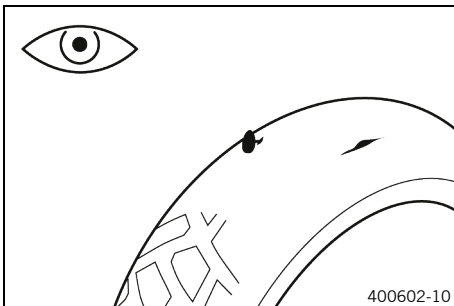

- Check the front and rear tires for cuts, run-in objects, and other damage.

» If the tires have cuts, run-in objects, or other damage:

- Change the tires. 🛠️

- Check the tread depth.



Info

Adhere to the legally required minimum tread depth.

Minimum tread depth	$\geq 2 \text{ mm } (\geq 0.08 \text{ in})$
---------------------	---

» If the tread depth is less than the minimum tread depth:

- Change the tires. 🛠️

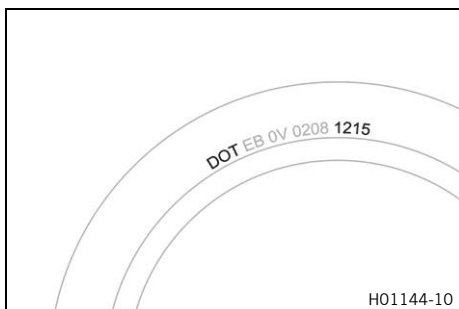

- Check the tire age.



Info

The tire date of manufacture is usually contained in the tire label and is indicated by the last four digits of the **DOT** number. The first two digits indicate the week of manufacture and the last two digits the year of manufacture.

KTM recommends that the tires be changed after 5 years at the latest, regardless of the actual state of wear.

- » If the tires are more than 5 years old:
 - Change the tires. 🛠️

15.7 Checking tire pressure



Info

Low tire pressure leads to abnormal wear and overheating of the tire.

Correct tire pressure ensures optimal riding comfort and maximum tire service life.

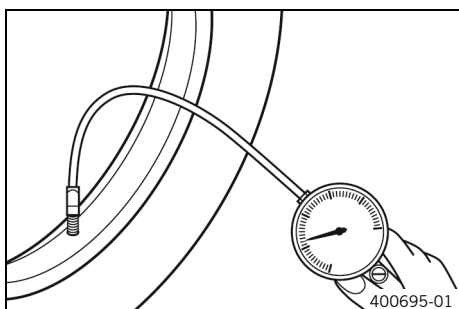

- Remove the protection cap.
- Check the tire pressure when the tires are cold.

Tire pressure, solo / with passenger / full payload	
front: with cold tires	2.4 bar (35 psi)
rear: with cold tires	2.9 bar (42 psi)

- » If the tire pressure does not meet specifications:
 - Correct the tire pressure.
- Mount the protection cap.

15.8 Checking spoke tension



Warning

Danger of accidents Incorrectly tensioned spokes impair the handling characteristic and result in secondary damage.

The spokes break due to being overloaded if they are too tightly tensioned. If the tension in the spokes is too low, then lateral and radial run-out will form in the wheel. Other spokes will become looser as a result.

- Check spoke tension regularly, and in particular on a new vehicle. (Your authorized KTM workshop will be glad to help.)

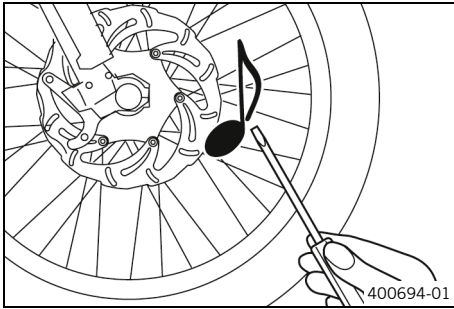

- Strike each spoke briefly using a screwdriver blade.



Info

The frequency of the sound depends on the spoke length and spoke diameter. If spokes of the same length and diameter vibrate with a different tone, this is an indication that the spoke tensions differ.

You should hear a high note.

- » If the spoke tension differs:
 - Correct the spoke tension. ↩



15.9 Using tire repair spray

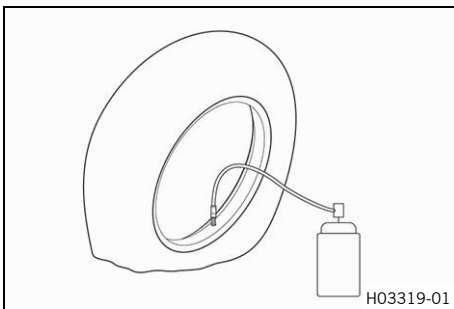

Warning

Danger of accidents Incorrect use of tire repair spray will result in the repaired tire losing pressure.

Tire repair spray cannot be used for all types of damage.

- Observe the instructions and specifications of the manufacturer of the tire repair spray.
- After repairing a tire with tire repair spray, ride slowly and carefully.
- Ride no further than to the nearest workshop and have the tire changed.

Tire repair spray should only be used in an emergency. We recommend transporting the broken down vehicle to the nearest workshop instead of using tire repair spray.

(SUPER ADVENTURE R EU/CN)

Note

Material damage Tire repair spray damages the tire pressure sensor.

- Note that after using tire repair spray, the tire pressure sensor may need to be replaced.

16.1 Low beam

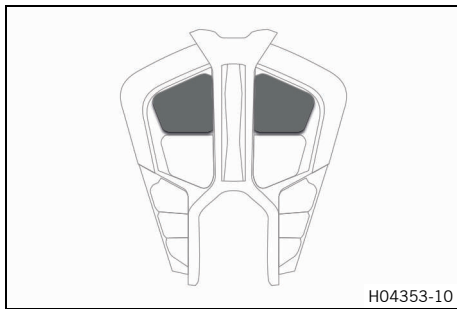

The low beam is integrated in the main headlight. The low beam is activated when the ignition is switched on. To save power in the 12-V battery, the low beam is deactivated again after 5 seconds if the engine is not started. If the ignition is accidentally switched off during the journey, the low beam remains on.

16.2 High beam

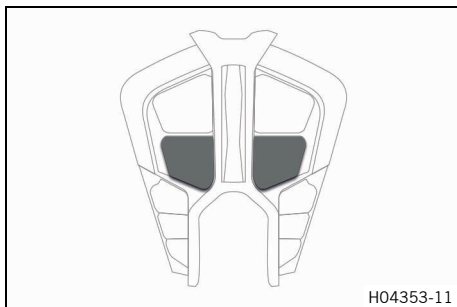

The high beam is integrated in the main headlight.

16.3 Daytime running light (DRL)

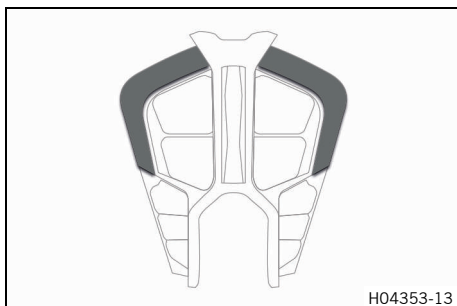

The daytime running (DRL)/position light is integrated in the main headlight.



Warning

Danger of accidents When visibility is poor, the daytime running light is not a substitute for the low beam.

Automatic switching between the daytime running light and low beam may only be partially available when visibility is significantly impaired due to fog, snow or rain.

- Ensure that the appropriate type of lighting is always selected.
- If necessary switch off the daytime running lights using the menu before going on a ride or when stopped so that the low beam is switched on permanently.
- Note the legal regulations regarding the daytime running light.

The daytime running light is brighter than the position light. The daytime running light must only be switched on when visibility conditions are good.

This is controlled by the ambient light sensor in the combination instrument. When visibility conditions are good, the low beam with position light is switched off and the daytime running light is switched on.

When the daytime running light is switched off, the low beam with position light lights up.

On high beam or headlight flasher, the daytime running light changes automatically to the position light.

16.4 Cornering light

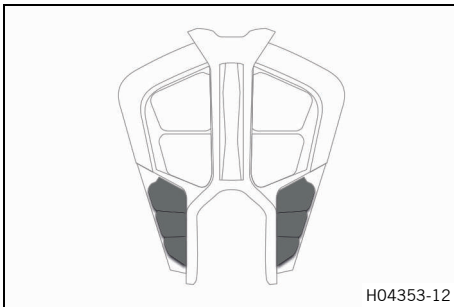

The cornering light is integrated into the main headlight.

i Info

To activate the cornering light, the low beam must be switched on and the daytime running light switched off.

The cornering light is activated.

Lean angle for the lower LED	$\geq 12^\circ$
Lean angle for the middle LED	$\geq 20^\circ$
Lean angle for the upper LED	$\geq 28^\circ$
Speed	$\geq 6 \text{ km/h}$ ($\geq 3.7 \text{ mph}$)

16.5 Removing the 12 V battery



Warning

Risk of injury Battery acid and battery gases cause serious chemical burns.

- Keep 12 V batteries out of the reach of children.
- Wear suitable protective clothing and safety glasses.
- Avoid contact with battery acid and battery gases.
- Keep sparks or open flames away from the 12 V battery.
- Only charge 12 V batteries in well-ventilated rooms.
- Rinse the affected area immediately with plenty of water in the event of contact with the skin.
- Rinse eyes with water for at least 15 minutes and consult a doctor immediately if battery acid and battery gases get into the eyes.



Caution

Danger of accidents Electronic components and safety devices will be damaged if the 12-V battery is discharged or missing.

If the 12-V battery is discharged or defective, malfunctions in the vehicle electronics can occur, especially when starting.

- Never operate the vehicle with a discharged 12-V battery or without a 12-V battery.

Preparatory work

- Remove the seat. (📖 p. 89)

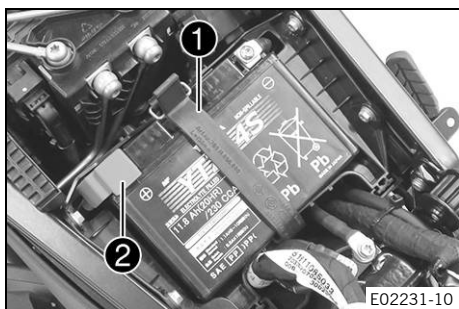

Main work

- Detach battery retainer rubber **1**.
- Remove positive terminal cover **2**.

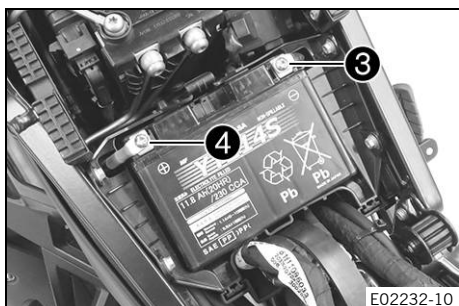

- Disconnect negative cable **3** from the 12 V battery.
- Disconnect positive cable **4** from the 12-V battery.
- Take the 12-V battery out of the battery compartment.

16.6 Installing the 12-V battery ↗

⚠ Warning

Risk of injury Battery acid and battery gases cause serious chemical burns.

- Keep 12 V batteries out of the reach of children.
- Wear suitable protective clothing and safety glasses.
- Avoid contact with battery acid and battery gases.
- Keep sparks or open flames away from the 12 V battery.
- Only charge 12 V batteries in well-ventilated rooms.
- Rinse the affected area immediately with plenty of water in the event of contact with the skin.
- Rinse eyes with water for at least 15 minutes and consult a doctor immediately if battery acid and battery gases get into the eyes.

⚠ Caution

Danger of accidents Electronic components and safety devices will be damaged if the 12-V battery is discharged or missing.

If the 12-V battery is discharged or defective, malfunctions in the vehicle electronics can occur, especially when starting.

- Never operate the vehicle with a discharged 12-V battery or without a 12-V battery.

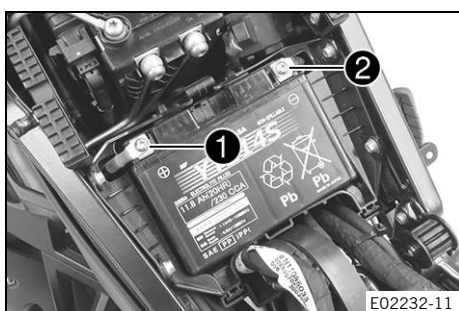

Main work

- Position the 12-V battery in the battery compartment.
- Position positive cable **1** and mount and tighten the screw.

Guideline

Screw, battery terminal	M6x12	4.5 Nm (3.32 lbf ft)
-------------------------	-------	-------------------------

- Position negative cable **2** and mount and tighten the screw.

Guideline

Screw, battery terminal	M6x12	4.5 Nm (3.32 lbf ft)
-------------------------	-------	-------------------------

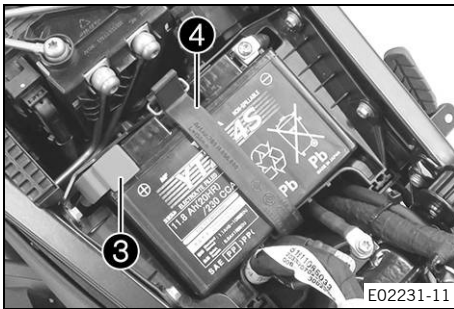

- Mount positive terminal cover ③.
- Attach battery retainer rubber ④.

Finishing work

- Mount the seat. (📖 p. 90)
- Set time and date. (📖 p. 59)



16.7 Charging the 12-V battery ↗



Warning

Risk of injury Battery acid and battery gases cause serious chemical burns.

- Keep 12 V batteries out of the reach of children.
- Wear suitable protective clothing and safety glasses.
- Avoid contact with battery acid and battery gases.
- Keep sparks or open flames away from the 12 V battery.
- Only charge 12 V batteries in well-ventilated rooms.
- Rinse the affected area immediately with plenty of water in the event of contact with the skin.
- Rinse eyes with water for at least 15 minutes and consult a doctor immediately if battery acid and battery gases get into the eyes.



Note

Environmental hazard 12 V batteries contain environmentally hazardous materials.

- Do not dispose of 12 V batteries as household waste.
- Dispose of 12 V batteries at a collection point for used batteries.



Note

Environmental hazard Hazardous substances cause environmental damage.

- Dispose of oils, grease, filters, fuel, cleaning agents, brake fluid, etc., correctly and in compliance with the applicable regulations.



Info

Even when there is no load on the 12-V battery, it discharges steadily each day.

The charging level and the method of charging are very important for the service life of the 12-V battery.

Rapid recharging with a high charging current shortens the service life of the battery.

If the charging current, charging voltage, and charging time are exceeded, electrolyte escapes through the safety valves. This reduces the capacity of the 12-V battery.

If the 12-V battery is depleted from starting the vehicle repeatedly, the battery must be charged immediately.

If the 12-V battery is left in a discharged state for an extended period, it will become deeply discharged and sulfating occurs, destroying the battery.

The 12-V battery is maintenance-free. The acid level does not have to be checked.

If the 12-V battery is not charged by the KTM battery charger, the 12-V battery must be removed for charging. Otherwise, overvoltage may damage electronic components. Charge the 12-V battery according to the instructions on the battery housing.

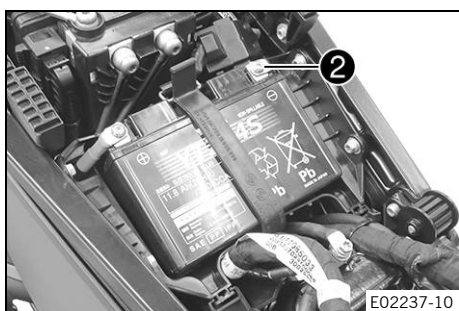
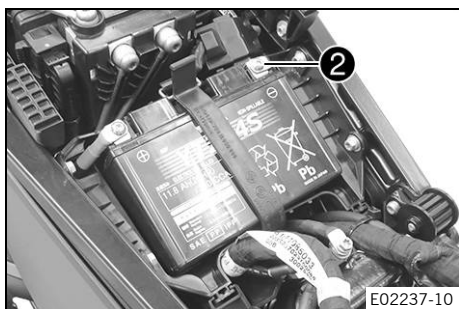
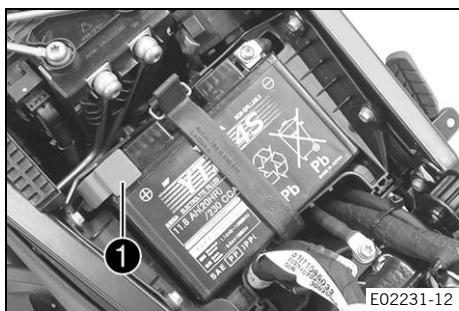

Preparatory work

- Remove the seat. (📖 p. 89)

Main work

- Remove positive terminal cover ❶.

- Disconnect negative cable ❷ from the 12 V battery to avoid damaging the onboard electronics.

- Connect a charger to the 12 V battery. Switch on the battery charger.

Battery charger (58429074200)

Info

You can also use the battery charger to test the open-circuit voltage and starting ability of the 12-V battery, and to test the alternator. In addition, you cannot over-charge the 12-V battery with this device.

Charge the 12-V battery to a maximum of 10 % of the capacity specified on the battery housing.

- Switch off the battery charger after charging and disconnect from the 12-V battery.

Guideline

The charging current, charging voltage, and charging time must not be exceeded.

Recharge the 12-V battery regularly when the motorcycle is not being used

3 months

- Connect negative cable ❷ to the 12 V battery.

Guideline

Screw, battery terminal

M6x12

4.5 Nm
(3.32 lbf ft)

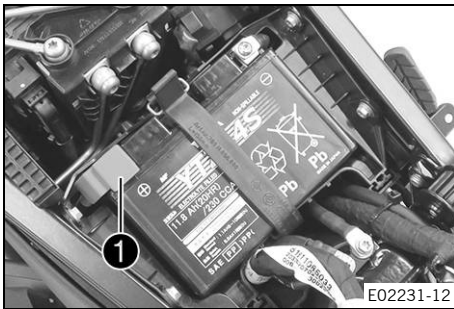

- Mount positive terminal cover ①.

Finishing work

- Mount the seat. (📖 p. 90)
- Set time and date. (📖 p. 59)



16.8 Changing the RACE-ON key battery



Warning

Risk of injury Button cells may burst if misused.

Swallowing button cells leads to severe chemical burning and may result in death in under 2 hours.

- Keep button cells and the RACE-ON key out of the reach of children.
- Make sure the button cells can never be swallowed or ingested.
- Seek medical attention immediately if button cells are swallowed or ingested.
- Do not expose button cells to extreme temperatures or mechanical loads.

Permissible temperature

-20 ... 50 °C (-4 ... 122 °F)

- Do not damage the RACE-ON key by e.g. cutting or squashing it.
- Do not use the RACE-ON key if the RACE-ON key is damaged or the battery compartment cannot be closed.
- Replace the RACE-ON key battery with the type specified only.

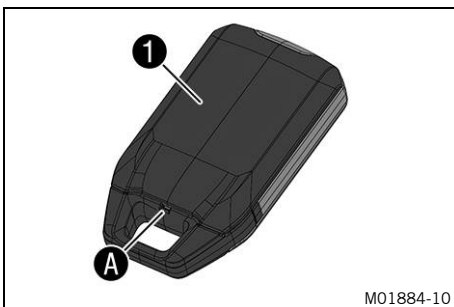

- To open cover ① of the RACE-ON key, insert a small, blunt object into opening A and carefully lift up the cover.

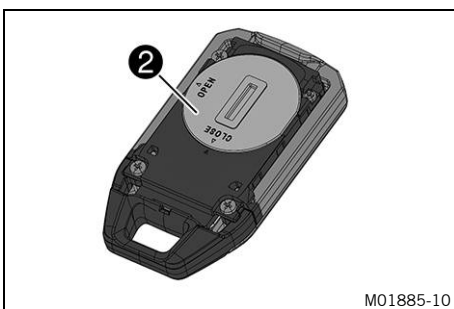

- Using a coin, turn battery cover ② counterclockwise and remove it.

Guideline

Ensure that the O-ring remains in place.

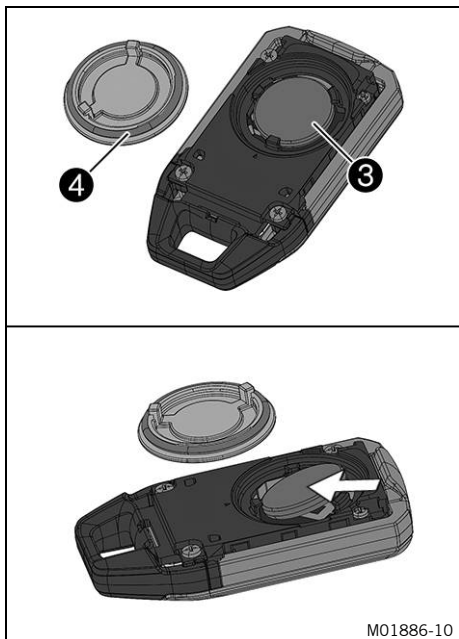

- Remove RACE-ON key battery ③.
- Insert the new RACE-ON key battery with label facing upward.

RACE-ON key battery (CR 2032) (📖 p. 161)

i Info

The two smaller holding lugs are tapered so that the RACE ON key battery can be easily pushed into the bracket.

- Mount battery cover with O-ring ④ and close it clockwise with a coin.
- Mount the cover of the RACE-ON key and click into place.

16.9 Changing the main fuse



Warning

Fire hazard Incorrect fuses overload the electrical system.

- Only use fuses with the required ampere value.
- Do not bypass or repair fuses.

Preparatory work

- Remove the seat. (📖 p. 89)

Main work

- Press the ① unlocking mechanism together.
- Take off protection cap ②.

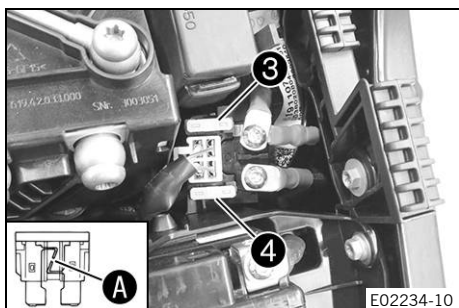
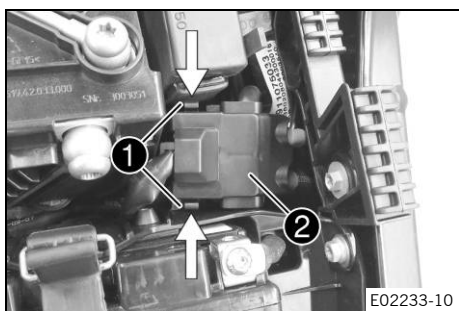

- Remove faulty main fuse ③.

i Info

A faulty fuse has a burned-out fuse wire **A**.
A spare fuse ④ is located in the starter relay.
The main fuse protects all electrical power consumers of the vehicle.

- Insert a new main fuse.

Fuse (58011109130) (📖 p. 161)

- Check that the electrical system is functioning properly.

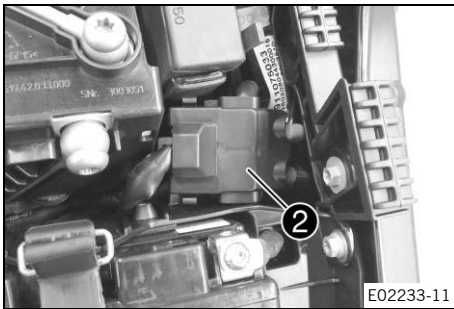

- Mount protection cap ②.
- ✓ The protection cap engages with an audible click.

i Tip
Insert a new spare fuse into the starter relay to have it available when needed.

Finishing work

- Mount the seat. (📖 p. 90)
- Set time and date. (📖 p. 59)



16.10 Changing the fuses in the fuse box

! Warning
Fire hazard Incorrect fuses overload the electrical system.

- Only use fuses with the required ampere value.
- Do not bypass or repair fuses.

i Info
The fuse box containing the fuses of individual electrical power consumers is located under the seat.

Preparatory work

- Remove the seat. (📖 p. 89)

Main work

- Open fuse box cover ①.

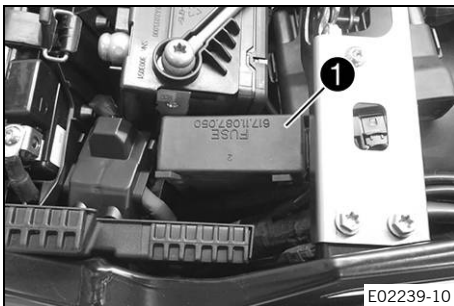

- Check the fuses.

i Info
A faulty fuse has a burned-out fuse wire ①.

- Remove the faulty fuse.

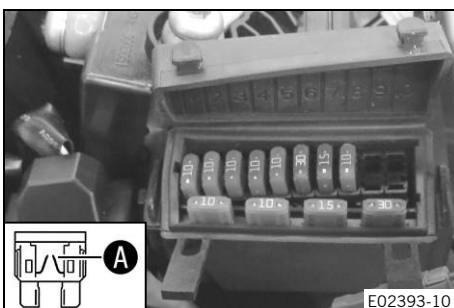

Guideline

Fuse **1** - 10 A - power supply for control units and components

Fuse **2** - 10 A - permanent positive for auxiliary equipment (accessories circuit 1)

Fuse **3** - 10 A - tail light, license plate lighting

Fuse **4** - 10 A - light control unit

Fuse **5** - 10 A - engine control unit

Fuse **6** - 30 A - ABS return pump

Fuse **7** - 15 A - ABS hydraulic unit

Fuse **8** - 10 A - ignition positive for auxiliary equipment (accessories circuit 2), USB power outlet

- Insert the spare fuse with the correct rating.

Fuse (58011109110) (📖 p. 161)

Fuse (58011109115) (📖 p. 161)

Fuse (58011109130) (📖 p. 161)

Tip

Insert a spare fuse so that it is available if needed.

- Check the function of the electrical power consumer.
- Close the fuse box cover.

Finishing work

- Mount the seat. (📖 p. 90)

16.11 Checking the headlight setting

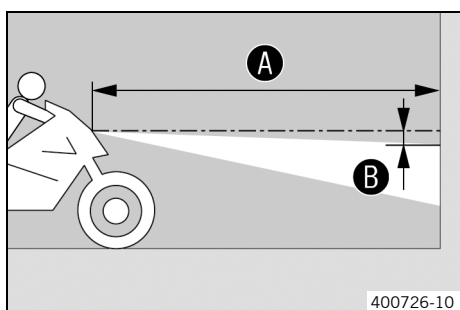

400726-10

- Park the vehicle on a horizontal surface in front of a light-colored wall and make a mark at the height of the center of the low beam headlight.
- Make another mark at a distance **B** under the first marking.

Guideline

Distance **B** 5 cm (2 in)

- Position the vehicle perpendicular to the wall at a distance **A** from the wall and switch on the low beam.

Guideline

Distance **A** 5 m (16 ft)

- The rider now mounts the motorcycle with luggage and passenger if applicable.
- Check the headlight setting.

The light-dark boundary must be exactly on the lower marking when the motorcycle is ready to be operated with the rider mounted along with any luggage and a passenger if applicable.

- » If the boundary between light and dark does not meet specifications:
 - Adjust the headlight range. (📖 p. 139)

16.12 Adjusting the headlight range

Preparatory work

- Check the headlight setting. (📖 p. 138)

Main work

- Turn adjusting wheel **1** to adjust the headlight range.



i Info

Turn counterclockwise to increase the headlight range; turn clockwise to reduce the headlight range. If you have a payload, you may have to correct the headlight range.

- Set the headlight to marking **B**.

Guideline

The light-dark boundary must lie exactly on lower marking **B** when the motorcycle is ready to operate with the rider mounted along with any luggage and a passenger if applicable.

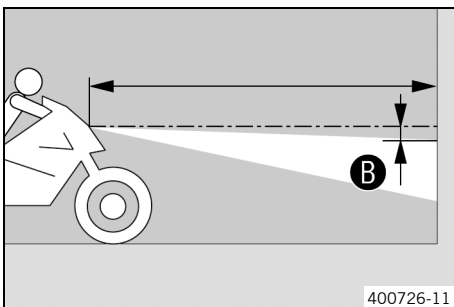

16.13 Diagnostics connector

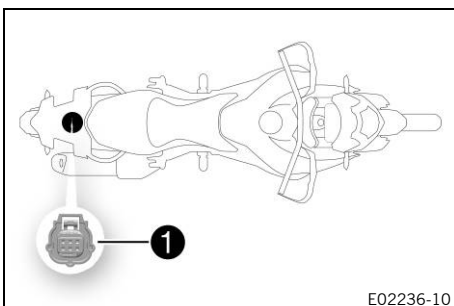

The diagnostics connector **1** is at the rear part of the vehicle.

(SUPER ADVENTURE R CN)

A diagnostic adapter for connection to a cross-manufacturer diagnostic interface has been connected at the factory.

i Info

Unplug the diagnostics adapter to use the KTM diagnostics tool. Following completion of the diagnosis, plug the diagnostics adapter back in.

16.14 Accessories circuit 1 and accessories circuit 2 front

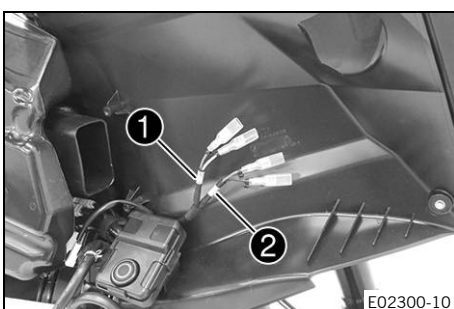

Installation location

- Accessories circuit 1 **1** and accessories circuit 2 **2** at the front are located behind the right mask spoiler.

i **Info**

The accessories circuits are protected by a fuse; however, this fuse also protects other electrical power consumers. The maximum continuous load is therefore significantly lower than the value of the fuse.

Do not use a stronger fuse.

The accessories circuit 1 is switched to permanent positive and connected electrical consumers are permanently supplied with current, regardless of ignition.

The accessories circuit 2 is switched to ignition positive, connected electrical consumers are only supplied with power when the ignition is switched on.

16.15 Accessories circuit 1 and accessories circuit 2, rear

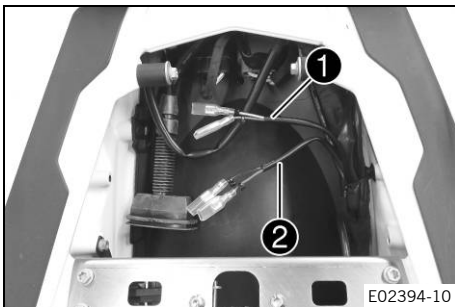
**Installation location**

- Accessories circuit 1 **1** and accessories circuit 2 **2** at the rear are located under the baggage carrier.
-

i **Info**

The accessories circuits are protected by a fuse; however, this fuse also protects other electrical power consumers. The maximum continuous load is therefore significantly lower than the value of the fuse.

Do not use a stronger fuse.

The accessories circuit 1 is switched to permanent positive and connected electrical consumers are permanently supplied with current, regardless of ignition.

The accessories circuit 2 is switched to ignition positive, connected electrical consumers are only supplied with power when the ignition is switched on.

17.1 Checking the coolant level in the compensating tank



Warning

Danger of scalding During motorcycle operation, the coolant gets very hot and is under pressure.

- Do not open the radiator, the radiator hoses or other cooling system components if the engine or the cooling system are at operating temperature.
- Allow the cooling system and the engine to cool down before you open the radiator, the radiator hoses or other components of the cooling system.
- In the event of scalding, rinse the area affected immediately with lukewarm water.



Warning

Danger of poisoning Coolant is toxic and a health hazard.

- Keep coolant out of the reach of children.
- Do not allow coolant to come into contact with the skin, the eyes and clothing.
- Consult a doctor immediately if coolant is swallowed.
- Rinse the affected area immediately with plenty of water in the event of contact with the skin.
- Rinse eyes thoroughly with water and consult a doctor immediately if coolant gets into the eyes.
- Change clothing if coolant spills onto your clothing.

Condition

The engine is cold.
The radiator is completely full.

- Park the motorcycle on a horizontal surface.
- Check the coolant level in compensating tank ①.

The coolant level must be between **min** and **max**.

- » If there is no coolant in the compensating tank:
 - Check the cooling system for leaks. 🛠️



Info

Do not start up the motorcycle!

- Add the coolant/bleed the cooling system. 🛠️
- » If the coolant level in the compensating tank is not at the required level, but the tank is not empty:
 - Correct the coolant level in the compensating tank. (📖 p. 141)



17.2 Correcting the coolant level in the compensating tank



Warning

Danger of scalding During motorcycle operation, the coolant gets very hot and is under pressure.

- Do not open the radiator, the radiator hoses or other cooling system components if the engine or the cooling system are at operating temperature.
- Allow the cooling system and the engine to cool down before you open the radiator, the radiator hoses or other components of the cooling system.
- In the event of scalding, rinse the area affected immediately with lukewarm water.



Warning

Danger of poisoning Coolant is toxic and a health hazard.

- Keep coolant out of the reach of children.
- Do not allow coolant to come into contact with the skin, the eyes and clothing.
- Consult a doctor immediately if coolant is swallowed.
- Rinse the affected area immediately with plenty of water in the event of contact with the skin.
- Rinse eyes thoroughly with water and consult a doctor immediately if coolant gets into the eyes.
- Change clothing if coolant spills onto your clothing.

Condition

The engine is cold.

The radiator is completely full.

Preparatory work

- Check the coolant level in the compensating tank. (📖 p. 141)
- Remove the front side spoiler. (📖 p. 101)

Condition

- Only remove the right side spoiler.

Main work

- Remove reservoir cover ❶.
- Add coolant until the coolant reaches the specified level.

Guideline

The coolant level must be between **min** and **max**.

Coolant (📖 p. 170)

- Mount cover ❶ of the compensating tank.

Finishing work

- Install the front side spoiler. (📖 p. 102)



18.1 Ride Mode

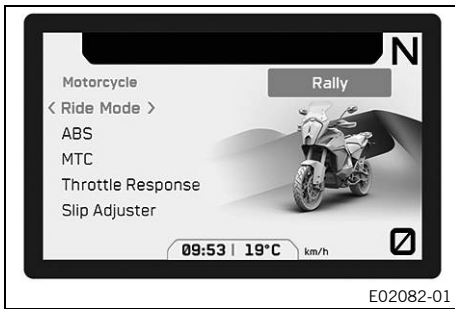

Possible states

- **SPORT** – Homologated performance with very direct response; the motorcycle traction control allows greater slip on the rear wheel.
- **STREET** – Homologated performance with balanced response; the motorcycle traction control allows normal slip on the rear wheel.
- **RAIN** – Reduced homologated performance with soft response for improved rideability on surfaces with low road grip; the motorcycle traction control allows very little slip on the rear wheel.
- **OFFROAD** – Reduced homologated performance for better rideability on unpaved roads; the motorcycle traction control allows high slip on the rear wheel.
- **RALLY** (optional) – Homologated performance and extremely direct response. The motorcycle traction control and the characteristics of the throttle response can be individually set.



Warning

Danger of accidents An incorrectly selected riding mode makes control of the vehicle considerably more difficult. The riding modes are each only suitable for certain conditions.

- Always select a riding mode that suits the surface on which you are riding, the weather and the riding situation.

Various vehicle tunings can be selected in the **Ride Mode** menu. **SPORT**, **STREET RAIN**, **OFFROAD** and **RALLY** (optional) are available. The most recently selected ride mode is displayed on the dash. The ride mode can also be changed while riding with a closed throttle and deactivated cruise control.

18.2 Motorcycle traction control (MTC)

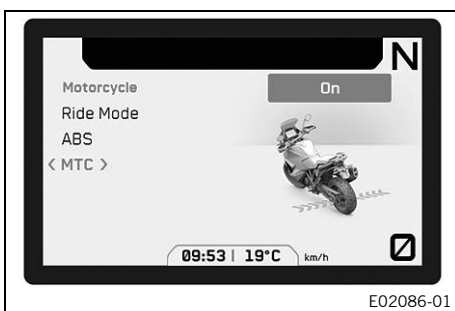

The motorcycle traction control (MTC) lowers the engine torque in case of loss of traction in the rear wheel. Depending on the riding mode (p. 143), different amounts of slip are allowed when traction control is activated.



Info

When motorcycle traction control is switched off, the rear wheel may spin during strong acceleration and on surfaces with low grip, resulting in a risk of falling. After the ignition is switched on, motorcycle traction control is enabled again.

The motorcycle traction control is adjusted using the **Motorcycle** menu on the dash. The motorcycle traction control can be switched off in the **MTC** menu.

i Info

When the motorcycle traction control is active, the TC indicator lamp flashes.
When motorcycle traction control is switched off, the TC indicator lamp lights up.

18.3 Slip Adjuster (optional)

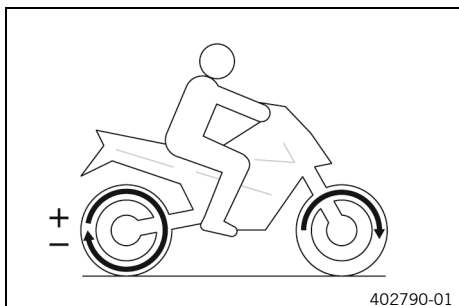

The spin adjuster is a motorcycle traction control function. The slip adjustment allows the motorcycle traction control to be tuned through nine levels to the desired characteristic map. Level 1 allows the maximum slip on the rear wheel, and level 9 the minimum.

The spin adjuster can be set when the cruise control is deactivated using the **+RES** or **-SET** button.

i Info

The spin adjuster is only available in **RALLY** ride mode (optional).
The spin adjuster is only available when motorcycle traction control is activated.

18.4 Throttle Response (optional)

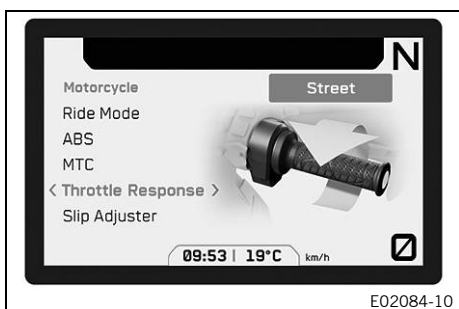

Possible states

- Street – Balanced response.
- Sport – Very direct response.
- Rally – Extremely direct response
- Offroad – Gentle response.

In the dash the characteristics of the throttle response can be adjusted via the **Throttle Response** submenu.

The **Throttle Response** can also be set while riding with a closed throttle grip.

i Info

Throttle Response is only available in riding mode **RALLY** (optional).

19.1 Checking the engine oil level

i Info

Oil consumption depends on the riding style and the operating conditions.

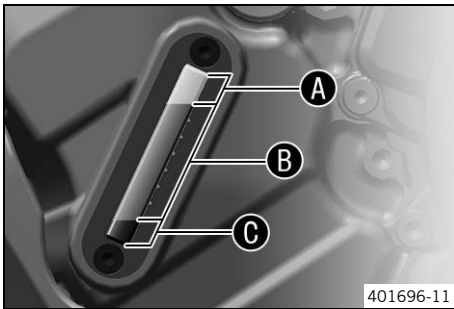

Condition

The engine is at operating temperature.

Preparatory work

- Stand the motorcycle upright on a horizontal surface.

Main work

- Check the engine oil level in the engine oil level viewer.

i Info

After switching off the engine, wait one minute before checking the level.

The engine oil level should be in the upper part of the range **B** of the engine oil level viewer.

- » When the engine oil level is in area **A** of the engine oil level viewer:
 - Do not add engine oil.
- » When the engine oil level is in area **B** of the engine oil level viewer:
 - Engine oil can be added.
- » When the engine oil level is in area **C** of the engine oil level viewer:
 - Add engine oil. (📖 p. 148)



19.2 Changing the engine oil and oil filter, cleaning the oil screens 🛠️



Warning

Danger of scalding Engine and gear oil get very hot when the motorcycle is ridden.

- Wear suitable protective clothing and safety gloves.
- In the event of scalding, rinse the area affected immediately with lukewarm water.



Note

Environmental hazard Hazardous substances cause environmental damage.

- Dispose of oils, grease, filters, fuel, cleaning agents, brake fluid, etc., correctly and in compliance with the applicable regulations.

Preparatory work

- Remove the engine guard. (📖 p. 108)
- Remove the oil plug cover. (📖 p. 109)

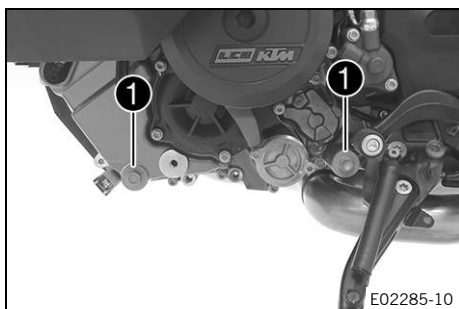

Main work

- Stand the motorcycle on a level surface using the side stand.
- Position an appropriate container under the engine.
- Remove oil drain plugs **1** along with the magnets, the O-rings, and the oil screens.

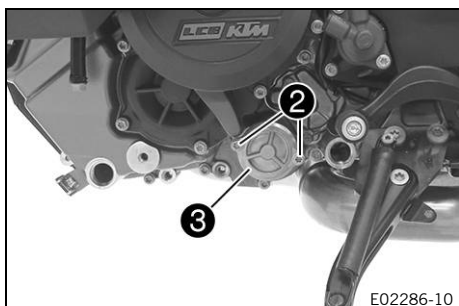

- Remove screws **2**. Take off oil filter cover **3** with the O-ring.

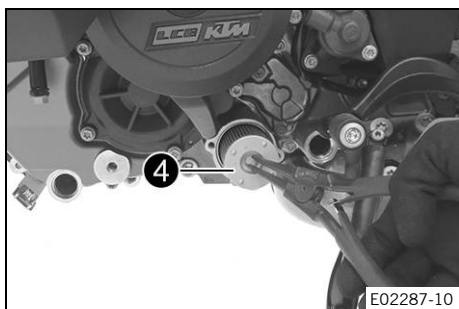

- Pull oil filter **4** out of the oil filter housing.

Lock ring plier (51012011000)

- Allow the engine oil to drain completely.
- Thoroughly clean the parts and the sealing surface.

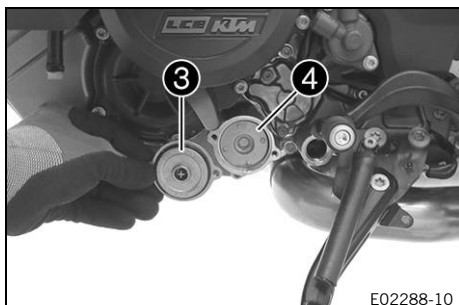

- Insert new oil filter **4**.

Info

Only insert the oil filter by hand.

- Oil the O-ring of the oil filter cover. Mount oil filter cover **3**.

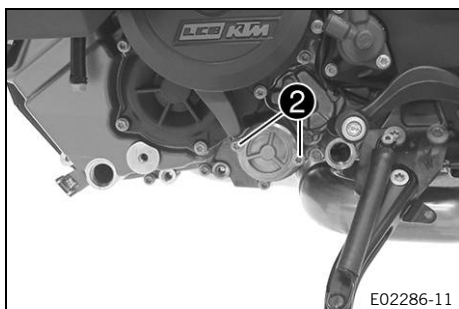

- Mount and tighten screws **2**.

Guideline

Remaining engine screws	M5	6 Nm (4.4 lbf ft)
-------------------------	----	-------------------

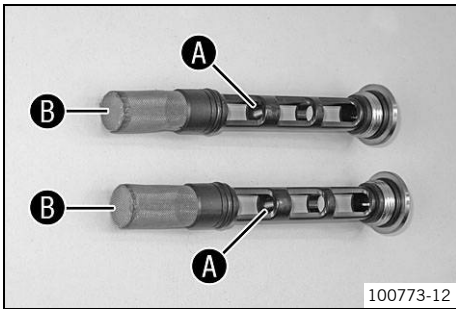

- Thoroughly clean magnets **A** and oil screens **B** of the oil drain plugs.

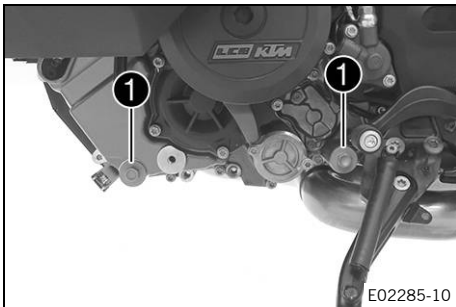

- Mount and tighten oil drain plugs **1** with magnets, O-rings, and oil screens.

Guideline

Oil drain plug	M20x1.5	20 Nm (14.8 lbf ft)
----------------	---------	---------------------

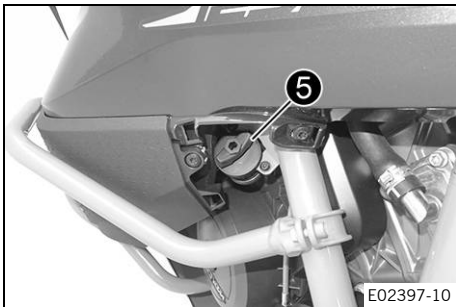

- Have the entire filling quantity available.

Engine oil Ambient temperature: $\geq 0\text{ }^{\circ}\text{C}$ ($\geq 32\text{ }^{\circ}\text{F}$)	3.60 l (3.8 qt.)	Engine oil (SAE 10W/50) (p. 170)
Engine oil Ambient temperature: $< 0\text{ }^{\circ}\text{C}$ ($< 32\text{ }^{\circ}\text{F}$)		Engine oil (SAE 5W/40) (p. 171)

- Add the oil quantity in two steps.
- Remove filler plug **5** with the O-ring, and fill up with the first partial quantity.

Engine oil (1st partial quantity) approx. Ambient temperature: $\geq 0\text{ }^{\circ}\text{C}$ ($\geq 32\text{ }^{\circ}\text{F}$)	3.0 l (3.2 qt.)	Engine oil (SAE 10W/50) (p. 170)
Engine oil (1st partial quantity) approx. Ambient temperature: $< 0\text{ }^{\circ}\text{C}$ ($< 32\text{ }^{\circ}\text{F}$)		Engine oil (SAE 5W/40) (p. 171)

- Mount filler plug **5** with the O-ring.



Danger

Danger of poisoning Exhaust gases are toxic and inhaling them may result in unconsciousness and death.

- Always make sure there is sufficient ventilation when running the engine.
- Use effective exhaust extraction when starting or running the engine in an enclosed space.

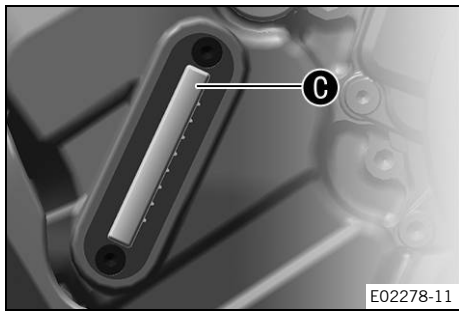

- Start the engine and check for leaks.
- Switch off the engine.
- Remove the filler plug with the O-ring and add the second partial quantity up to the upper marking **C** on the engine oil level viewer.

Engine oil (2nd partial quantity) approx. Ambient temperature: $\geq 0\text{ }^{\circ}\text{C}$ ($\geq 32\text{ }^{\circ}\text{F}$)	0.60 l (0.63 qt.)	Engine oil (SAE 10W/50) (📖 p. 170)
Engine oil (2nd partial quantity) approx. Ambient temperature: $< 0\text{ }^{\circ}\text{C}$ ($< 32\text{ }^{\circ}\text{F}$)		Engine oil (SAE 5W/40) (📖 p. 171)

- Mount the filler plug with the O-ring.



Danger

Danger of poisoning Exhaust gases are toxic and inhaling them may result in unconsciousness and death.

- Always make sure there is sufficient ventilation when running the engine.
- Use effective exhaust extraction when starting or running the engine in an enclosed space.

- Start the engine and check for leaks.

Finishing work

- Check the engine oil level. (📖 p. 145)
- Install the oil plug cover. (📖 p. 109)
- Install the engine guard. (📖 p. 108)

19.3 Adding engine oil

i Info

Too little engine oil or poor-quality engine oil results in premature wear to the engine. The engine may be damaged if the engine oil level is too high.

Condition

The engine is at operating temperature.

Preparatory work

- Stand the motorcycle upright on a horizontal surface.
- Check the engine oil level. (📖 p. 145)

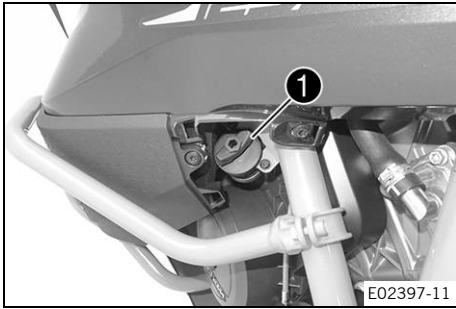

E02397-11

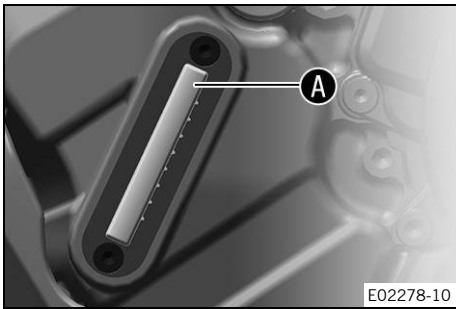

E02278-10

Main work

- Remove filler plug ① with the O-ring.

- Add the engine oil to upper marking A on the engine oil level viewer.

Condition

Ambient temperature: $\geq 0\text{ }^{\circ}\text{C}$ ($\geq 32\text{ }^{\circ}\text{F}$)

Engine oil (SAE 10W/50) (📖 p. 170)

Condition

Ambient temperature: $< 0\text{ }^{\circ}\text{C}$ ($< 32\text{ }^{\circ}\text{F}$)

Engine oil (SAE 5W/40) (📖 p. 171)



Info

In order to achieve optimal engine oil performance, it is not advisable to mix different engine oils. KTM recommends changing the engine oil.

- Mount the filler plug with the O-ring.



Danger

Danger of poisoning Exhaust gases are toxic and inhaling them may result in unconsciousness and death.

- Always make sure there is sufficient ventilation when running the engine.
- Use effective exhaust extraction when starting or running the engine in an enclosed space.

- Start the engine and check for tightness.

Finishing work

- Check the engine oil level. (📖 p. 145)



20.1 Cleaning the motorcycle

Note

Material damage Components become damaged or destroyed if a pressure cleaner is used incorrectly. The high pressure forces water into the electrical components, connectors, throttle cables, and bearings, etc. Pressure which is too high causes malfunctions and destroys components.

- Do not direct the water jet directly on to electrical components, connectors, throttle cables or bearings.
- Maintain a minimum distance between the nozzle of the pressure cleaner and the component.
Minimum clearance 60 cm (23.6 in)



Note

Environmental hazard Hazardous substances cause environmental damage.

- Dispose of oils, grease, filters, fuel, cleaning agents, brake fluid, etc., correctly and in compliance with the applicable regulations.



Info

To maintain the value and appearance of the motorcycle over a long period, clean it regularly. Avoid direct sunshine when cleaning the motorcycle.

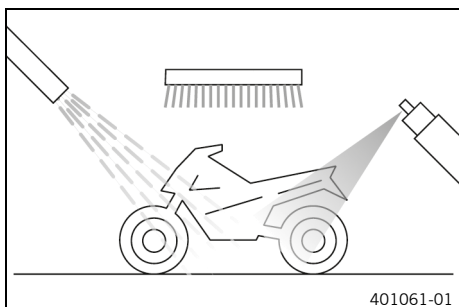

- Close off exhaust system to keep water from entering.
- Remove loose dirt first with a soft jet of water.
- Spray the heavily soiled parts with a normal commercial motorcycle cleaner and clean using a brush.

Motorcycle cleaner (📖 p. 172)



Info

Use warm water containing normal motorcycle cleaner and a soft sponge. Never apply motorcycle cleaner to a dry vehicle; always rinse the vehicle with water first. If the vehicle was operated in road salt, clean it with cold water. Warm water would enhance the corrosive effects of salt.

- After rinsing the motorcycle with a gentle spray of water, allow it to dry thoroughly.
- Remove the closure of the exhaust system.



Warning

Danger of accidents Moisture and dirt impair the brake system.

- Brake carefully several times to dry out and remove dirt from the brake linings and the brake discs.

- After cleaning, ride the vehicle a short distance until the engine warms up.



Info

The heat produced causes water at inaccessible locations in the engine and on the brake system to evaporate.

- Push back the protection caps of the handlebar controls to allow any water that has penetrated to evaporate.
- After the motorcycle has cooled down, lubricate all moving parts and pivot points.
- Clean the chain. (📖 p. 90)
- Treat bare metal (except for brake discs and the exhaust system) with a corrosion inhibitor.

Preserving materials for paints, metal and rubber (📖 p. 172)

- Treat the painted parts with a mild paint polish.

Perfect finish and high gloss polish for paints (📖 p. 172)



Info

Do not polish parts that were matte when delivered as this would strongly impair the material quality.

- Treat the plastic parts and powder-coated parts with a mild cleaning and care product.

Special cleaner for glossy and matte paint finishes, metal and plastic surfaces (📖 p. 172)

- Oil the ignition and steering lock, tank lock, and seat lock.

Universal oil spray (📖 p. 172)



20.2 Checks and maintenance steps for winter operation



Info

If you use the motorcycle in winter, you must expect salt on the roads. You should therefore take precautions against aggressive road salt. If the vehicle has been used on salted roads, use cold water for cleaning after riding. Warm water enhances the corrosive effects of salt.

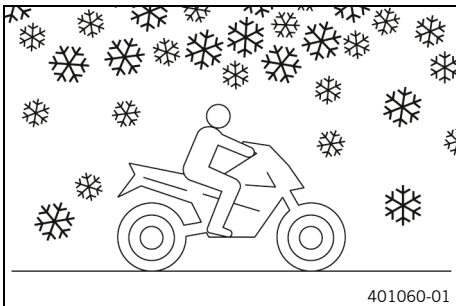

- Clean the motorcycle. (📖 p. 150)
- Clean the brakes.



Info

After **EVERY** trip on salted roads, thoroughly clean the brake calipers and brake linings, after they have cooled down and without removing them, with cold water and dry them carefully. After riding on salted roads, thoroughly clean the motorcycle with cold water and dry it well.

- Treat the engine, the link fork, and all other bare or zinc-plated parts (except the brake discs) with a wax-based corrosion inhibitor.



Info

Corrosion inhibitor must not come into contact with the brake discs. This would severely lower the braking effect.

- Clean the chain. (📖 p. 90)



21.1 Storage

i Info

If you plan to garage the motorcycle for a longer period, perform the following steps or have them performed.

Before storing the motorcycle, check all parts for function and wear. If service, repairs, or replacements are necessary, you should do this during the storage period (less workshop overload). In this way, you can avoid long workshop waiting times at the start of the new season.

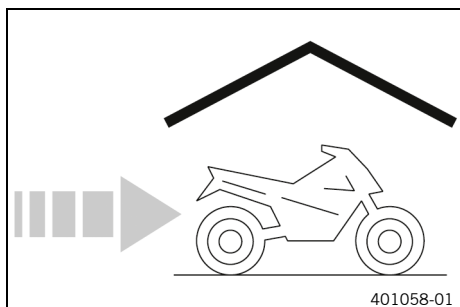

- When refueling for the last time before taking the motorcycle out of service, add fuel additive.

Fuel additive (📖 p. 172)

- Refuel. (📖 p. 80)
- Clean the motorcycle. (📖 p. 150)
- Change the engine oil and the oil filter, clean the oil screens. 🛠️ (📖 p. 145)
- Check the coolant fill level and antifreeze. 🛠️
- Check tire pressure. (📖 p. 128)
- Remove the 12 V battery. 🛠️ (📖 p. 131)

Guideline

Storage temperature of the 12-V battery without direct sunlight	0 ... 35 °C (32 ... 95 °F)
---	----------------------------

- Charge the 12-V battery. 🛠️ (📖 p. 133)
- Store the vehicle in a dry location that is not subject to large fluctuations in temperature.
- Raise the vehicle with the center stand. (📖 p. 89)
- Cover the motorcycle with a tarp or cover that is permeable to air.

i Info

Do not use non-porous materials since they prevent humidity from escaping, thus causing corrosion. Avoid running the engine for a short time only. Since the engine cannot warm up properly, the water vapor produced during combustion condenses and causes valves and the exhaust system to rust.



21.2 Preparing for use after storage

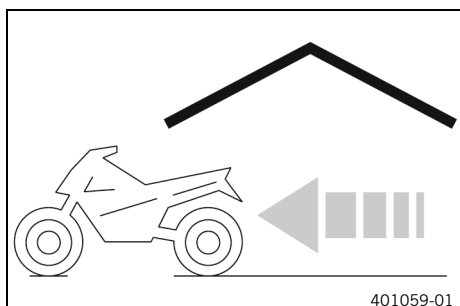

- Remove the vehicle from the center stand. (📖 p. 89)
- Install the 12-V battery. 🛠️ (📖 p. 132)

i Info

If the 12-V battery was removed, the time and date must be set.

- Perform checks and maintenance measures when preparing for use. (📖 p. 72)
- Take a test ride.





E02045-10

The RACE ON indicator light **1** can indicate malfunctions by flashing. These are indicated up to five seconds after the RACE ON button is actuated.

i Info
Blink codes referring to **KTM RACE ON** are only displayed once and not repeated.

Faults	Possible cause	Action
No response if the RACE ON button is pressed	RACE-ON button faulty	<ul style="list-style-type: none"> – Check the RACE-ON button for damage. – Check the cable and the plug of the RACE-ON button for damage.
RACE ON indicator light flashes twice	No response signal from the RACE ON key	<ul style="list-style-type: none"> – Ensure that the RACE ON key anti-relay attack mode has been deactivated. – Ensure that the RACE ON key is in range. – Remove other electronic devices from the vicinity of the RACE-ON antenna. – Check the battery compartment in the RACE-ON key for correct locking. – Check the battery compartment of the RACE-ON key for corrosion. – Change the RACE-ON key battery. (📖 p. 135) – Hold RACE ON chip or RACE ON key directly to the <u>vehicle antenna</u> (📖 p. 21).
RACE-ON indicator lamp flashes three times	12-V battery discharged	<ul style="list-style-type: none"> – Charge the 12-V battery. (📖 p. 133) – Check the open-circuit current. (🔧)
RACE-ON indicator lamp flashes four times	Steering lock bolt locked or tense	<ul style="list-style-type: none"> – Move handlebar slightly.
RACE-ON indicator lamp flashes five times	RACE ON antenna faulty	<ul style="list-style-type: none"> – Check the RACE-ON antenna for damage.
RACE ON indicator light flashes six times	Electronic fault	<ul style="list-style-type: none"> – Read out the fault memory using the KTM diagnostics tool. (🔧)
RACE ON indicator light flashes seven times	Anti-relay attack mode on RACE ON key could not be activated.	<ul style="list-style-type: none"> – Switch the ignition on and off again while the RACE ON key is within range of the vehicle.
The combination instrument shows nothing on the display	Fuse 1 blown	<ul style="list-style-type: none"> – Change the fuses in the fuse box. (📖 p. 137)
	Main fuse burned out	<ul style="list-style-type: none"> – Change the main fuse. (📖 p. 136)
	12-V battery discharged	<ul style="list-style-type: none"> – Charge the 12-V battery. (📖 p. 133) – Check the open-circuit current. (🔧)
Engine does not rotate if the start button/emergency OFF switch is pressed into the lower position	Operating error	<ul style="list-style-type: none"> – Carry out start procedure. (📖 p. 72)
	12-V battery discharged	<ul style="list-style-type: none"> – Charge the 12-V battery. (📖 p. 133) – Check the open-circuit current. (🔧)

Faults	Possible cause	Action
Engine does not rotate if the start button/emergency OFF switch is pressed into the lower position	Faulty safety starting system	– Read out the fault memory using the KTM diagnostics tool. 🛠️
	Electronic fault	– Read out the fault memory using the KTM diagnostics tool. 🛠️
Engine turns only if the clutch lever is drawn	The vehicle is in gear	– Shift the transmission into neutral.
	Faulty safety starting system	– Read out the fault memory using the KTM diagnostics tool. 🛠️
Engine turns although a gear is engaged	Faulty safety starting system	– Read out the fault memory using the KTM diagnostics tool. 🛠️
Engine turns but does not start	Quick release coupling not joined	– Join quick release coupling.
	Malfunction in the electronic fuel injection	– Read out the fault memory using the KTM diagnostics tool. 🛠️
	Fuel quality is insufficient	– Add suitable fuel.
Engine dies during the trip	Lack of fuel	– Refuel. (📖 p. 80)
	Malfunction in the electronic fuel injection	– Read out the fault memory using the KTM diagnostics tool. 🛠️
Malfunction indicator lamp lights up	Malfunction in the electronic fuel injection	– Read out the fault memory using the KTM diagnostics tool. 🛠️
The ABS warning lamp lights up	ABS fuse blown	– Change the fuses in the fuse box. (📖 p. 137)
	Wheel speeds of front and rear wheels differ greatly	– Stop, switch off the ignition, start again.
	Malfunction in ABS	– Read out the fault memory using the KTM diagnostics tool. 🛠️
High oil consumption	Engine oil level too high	– Check the engine oil level. (📖 p. 145)
	Engine oil too thin (low viscosity)	– Change the engine oil and the oil filter, clean the oil screens. 🛠️ (📖 p. 145)
12-V battery discharged	An electrical power consumer is connected to the socket/ACC1.	– Disconnect the electrical power consumer from the socket/ACC1. – Charge the 12-V battery. 🛠️ (📖 p. 133)
	The hazard warning flasher is switched on	– Switch off the hazard warning flasher. – Charge the 12-V battery. 🛠️ (📖 p. 133)
	The 12-V battery is not being charged by the alternator	– Check the charging voltage. 🛠️
	Ignition was not switched off when vehicle was parked	– Charge the 12-V battery. 🛠️ (📖 p. 133)

23.1 Engine

Design	2-cylinder 4-stroke Otto engine, 75° V arrangement, water-cooled
Displacement	1,301 cm ³ (79.39 cu in)
Stroke	71 mm (2.8 in)
Bore	108 mm (4.25 in)
Compression ratio	13.1:1
Idle speed	1,280 ... 1,480 rpm
Control	DOHC, 4 valves per cylinder, chain-driven
Valve - valve plate diameter	
Intake	42 mm (1.65 in)
Exhaust	34 mm (1.34 in)
Valve clearance	
Intake at: 20 °C (68 °F)	0.10 ... 0.15 mm (0.0039 ... 0.0059 in)
Exhaust at: 20 °C (68 °F)	0.25 ... 0.30 mm (0.0098 ... 0.0118 in)
Crankshaft bearing	Sleeve bearing
Conrod bearing	Sleeve bearing
Piston	Forged light alloy
Piston ring	1 compression ring, 1 scraper ring, 1 oil control ring
Engine lubrication	Dry sump lubrication system with 3 trochoidal pumps
Primary transmission	40:76
Clutch	Antihopping clutch in oil bath/hydraulically operated
Transmission	6-gear transmission, claw shifted
Transmission ratio	
first-gear	12:35
second-gear	15:32
third-gear	18:30
fourth-gear	20:27
fifth-gear	24:27
sixth-gear	35:32
Mixture preparation	Electronic fuel injection
Ignition system	Contactless controlled fully electronic ignition with digital ignition adjustment
Alternator	12 V, 450 W
Spark plug	
Inside spark plug	NGK LKAR9DI-10
Outside spark plug	NGK LMAR7DI-10
Electrode gap, spark plug	1 mm (0.04 in)
Cooling	Water cooling, permanent circulation of coolant by water pump
Cold start device	Starter motor

23.2 Engine tightening torques



Screw, air filter box cover, long	EJOT Delta PT® 60x30	2.5 Nm (1.84 lbf ft)
Screw, air filter box cover, short	EJOT Delta PT® 60x20	2 Nm (1.5 lbf ft)
Screw, damping plate	EJOT ALtracs® M6x14	10 Nm (7.4 lbf ft) Loctite®243™
Screw, intake air temperature sensor	EJOT PT® K50x16	2 Nm (1.5 lbf ft)
Screw, retaining bracket, valve cover, rear	EJOT ALtracs® M6x12	8 Nm (5.9 lbf ft)
Screw, SAS plate on air filter box	EJOT PT® K50x16	2 Nm (1.5 lbf ft)
Hose clip, intake flange	M4	1.5 Nm (1.11 lbf ft)
Camshafts, oil spray jet	M5	2 Nm (1.5 lbf ft) Loctite®243™
Oil nozzle	M5	2 Nm (1.5 lbf ft) Loctite®243™
Remaining engine screws	M5	6 Nm (4.4 lbf ft)
Screw, bearing retainer	M5	5 Nm (3.7 lbf ft) Loctite®243™
Screw, bearing shells retaining bracket	M5	6 Nm (4.4 lbf ft) Loctite®243™
Screw, cable duct on the engine fixing arm	M5x12	5 Nm (3.7 lbf ft)
Screw, crankshaft speed sensor	M5	6 Nm (4.4 lbf ft) Loctite®243™
Screw, engine oil level viewer	M5	4 Nm (3 lbf ft) Loctite®243™
Screw, gear position sensor	M5	5 Nm (3.7 lbf ft) Loctite®243™
Screw, intake trumpet	M5x25	6 Nm (4.4 lbf ft)
Screw, oil filter cover	M5x16	6 Nm (4.4 lbf ft)
Screw, resonator	M5	8 Nm (5.9 lbf ft) Loctite®243™
Screw, shift shaft sensor	M5	5 Nm (3.7 lbf ft) Loctite®243™
Screw, swingarm sensor	M5x12 – 8.8	5 Nm (3.7 lbf ft) Loctite®243™
Nut, cylinder head	M6	8 Nm (5.9 lbf ft)
Nut, starter cable	M6	4 Nm (3 lbf ft)
Remaining engine screws	M6	10 Nm (7.4 lbf ft)
Screw, alternator cover	M6	10 Nm (7.4 lbf ft)
Screw, camshaft bearing support	M6x25 – 10.9	10 Nm (7.4 lbf ft)
Screw, clutch cover	M6	10 Nm (7.4 lbf ft)
Screw, clutch pressure plate	M6	12 Nm (8.9 lbf ft)
Screw, coolant connection on the cylinder head	M6x20	8 Nm (5.9 lbf ft) Loctite®243™
Screw, coolant cylinder head bleeder	M6x10	6 Nm (4.4 lbf ft)
Screw, engine case	M6x60	10 Nm (7.4 lbf ft)

Screw, engine case	M6x80	10 Nm (7.4 lbf ft)	
Screw, engine case	M6x90	10 Nm (7.4 lbf ft)	
Screw, freewheel ring	M6x20 – 10.9	15 Nm (11.1 lbf ft)	Loctite® 648™
Screw, heat exchanger	M6	10 Nm (7.4 lbf ft)	Loctite® 243™
Screw, kick-starter gear support	M6	10 Nm (7.4 lbf ft)	Loctite® 243™
Screw, locking lever	M6	10 Nm (7.4 lbf ft)	Loctite® 243™
Screw, oil filler neck	M6x20	10 Nm (7.4 lbf ft)	Loctite® 243™
Screw, oil pump cover	M6	10 Nm (7.4 lbf ft)	Loctite® 243™
Screw, SAS flange	M6x12	10 Nm (7.4 lbf ft)	
Screw, shift drum locating unit	M6x30 – 12.9	15 Nm (11.1 lbf ft)	Loctite® 243™
Screw, shift lever	M6x20	18 Nm (13.3 lbf ft)	Loctite® 243™
Screw, starter motor	M6	10 Nm (7.4 lbf ft)	
Screw, stator	M6	10 Nm (7.4 lbf ft)	Loctite® 243™
Screw, stick coil	M6	8 Nm (5.9 lbf ft)	
Screw, swingarm sensor	M6x20	10 Nm (7.4 lbf ft)	Loctite® 243™
Screw, tube for oil cooler	M6x16	10 Nm (7.4 lbf ft)	Loctite® 243™
Screw, valve cover	M6	10 Nm (7.4 lbf ft)	
Screw, water pump cover	M6	10 Nm (7.4 lbf ft)	
Screw, water pump wheel	M6	10 Nm (7.4 lbf ft)	Loctite® 243™
Stud, timing chain shaft	M6	3 Nm (2.2 lbf ft)	
Vacuum connection	M6	2.5 Nm (1.84 lbf ft)	Loctite® 243™
Clutch lubricating jet	M6x0.75	2 Nm (1.5 lbf ft)	
Jet 100 for crankcase ventilation	M6x0.75	3 Nm (2.2 lbf ft)	Loctite® 243™
Screw plug, locking screw	M8	12 Nm (8.9 lbf ft)	
Screw, camshaft bearing support	M8x30 – 10.9	1st stage 10 Nm (7.4 lbf ft) 2nd stage 18 Nm (13.3 lbf ft)	
Screw, engine case	Expansion screw M8	18 Nm (13.3 lbf ft)	
Screw, guide rail	M8	15 Nm (11.1 lbf ft)	Loctite® 243™
Screw, tensioning rail	M8	15 Nm (11.1 lbf ft)	Loctite® 243™
Stud, exhaust flange	M8	10 Nm (7.4 lbf ft)	
Screw, engine brace	M10x24	45 Nm (33.2 lbf ft)	
Oil pressure sensor	M10x1	15 Nm (11.1 lbf ft)	

Screw plug, cam lever axis	M10x1	12 Nm (8.9 lbf ft)
Screw plug, clutch lubrication	M10x1	8 Nm (5.9 lbf ft)
Screw plug, spreading transmission lock	M10x1	12 Nm (8.9 lbf ft)
Screw, conrod bearing	M10x1	Step 1 25 Nm (18.4 lbf ft) Step 2 30 Nm (22.1 lbf ft) Step 3 90°
Screw, unlocking of timing chain tensioner	M10x1	8 Nm (5.9 lbf ft)
Spark plug (outside)	M10x1	11 Nm (8.1 lbf ft)
Coolant temperature sensor	M10x1.25	12 Nm (8.9 lbf ft)
Cylinder head screw	M11x1.5	Tightening sequence: Using a crisscross pattern Step 1 15 Nm (11.1 lbf ft) Step 2 30 Nm (22.1 lbf ft) Step 3 90° Step 4 90° Lubricated with engine oil
Screw, swingarm deflector	M12x90	80 Nm (59 lbf ft)
Screw, ignition rotor	Expansion screw M12x1.5	115 Nm (84.8 lbf ft)
Spark plug (central)	M12x1.5	18 Nm (13.3 lbf ft)
Nut of engine sprocket	M20x1.5	100 Nm (73.8 lbf ft) Loctite®243™
Oil drain plug	M20x1.5	20 Nm (14.8 lbf ft)
Nut, inner clutch hub	M22x1.5	140 Nm (103.3 lbf ft)
Plug, timing-chain tensioner	M24x1.5	25 Nm (18.4 lbf ft)
Screw plug, alternator cover	M24x1.5	8 Nm (5.9 lbf ft)
Nut, primary gear wheel	M33LHx1.5	130 Nm (95.9 lbf ft) Loctite®243™

23.3 Capacities

23.3.1 Engine oil

Engine oil Ambient temperature: ≥ 0 °C (≥ 32 °F)	3.60 l (3.8 qt.)	Engine oil (SAE 10W/50) ( p. 170)
Engine oil Ambient temperature: < 0 °C (< 32 °F)		Engine oil (SAE 5W/40) ( p. 171)

23.3.2 Coolant

Coolant	2 l (2 qt.)	Coolant ( p. 170)
---------	-------------	---

23.3.3 Fuel

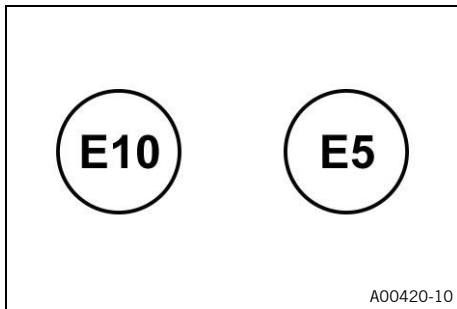

Please observe the labels on EU fuel pumps.

Fuel reserve, approx.	5 l (1.3 US gal)	
Total fuel tank capacity, approx.	23 l (6.1 US gal)	Super unleaded (ROZ 95) (📖 p. 171)

23.4 Chassis

Frame	Lattice frame made of chrome molybdenum steel tubing, powder-coated
Fork	WP Suspension XPLOR 5548
Shock absorber	WP Suspension XPLOR 5746
Suspension travel	
front	220 mm (8.66 in)
rear	220 mm (8.66 in)
Brake system	
front	Double disc brake with radially mounted four-piston brake calipers, floating brake discs
rear	Single disc brake with dual-piston brake caliper, floating brake disc
Brake discs - diameter	
front	320 mm (12.6 in)
rear	267 mm (10.51 in)
Brake discs - wear limit	
front	4 mm (0.16 in)
rear	4.5 mm (0.177 in)
Tire pressure, solo / with passenger / full payload	
front: with cold tires	2.4 bar (35 psi)
rear: with cold tires	2.9 bar (42 psi)
Secondary drive ratio	17:42
Chain	5/8 x 5/16" (525) X-ring
Steering head angle	64.6°
Wheelbase	1,578 ± 15 mm (62.13 ± 0.59 in)
Seat height, unloaded	880 mm (34.65 in)
Ground clearance, unloaded	242 mm (9.53 in)
Weight without fuel, approx.	228 kg (503 lb.)
Maximum permissible front axle load	169 kg (373 lb.)
Maximum permissible rear axle load	281 kg (619 lb.)

Maximum permissible total weight	450 kg (992 lb.)
----------------------------------	------------------

23.5 Electrical system

12-V battery	YTZ14S	Battery voltage: 12 V Nominal capacity: 11.2 Ah Maintenance-free
RACE-ON key battery	CR 2032	3 V
Fuse	58011109110	10 A
Fuse	58011109115	15 A
Fuse	58011109130	30 A

Low beam	LED
High beam	LED
Position light	LED
Cornering light	LED
Combination instrument lighting and indicator lamps	LED
Turn signal	LED
Tail light	LED
Brake light	LED
License plate lamp	LED

23.6 Tires

Front tire	Rear tire
90/90 - 21 M/C 54V TL Bridgestone A41 F	150/70 ZR 18 M/C 70W TL Bridgestone A41 R
The tires specified represent one of the possible series production tires. Additional information is available in the Service section under: http://www.ktm.com	

23.7 Fork

Fork article number	14.18.8U.25
Fork	WP Suspension XPLOR 5548
Compression damping	
Comfort	21 clicks
Standard	15 clicks
Sport	10 clicks
Full payload	10 clicks
Rebound damping	
Comfort	21 clicks
Standard	15 clicks
Sport	10 clicks
Full payload	10 clicks
Spring preload – preload adjuster	
Comfort	0 turns
Standard	0 turns
Sport	0 turns

Full payload	6 turns	
Spring length with preload spacer(s)	439 mm (17.28 in)	
Spring rate		
Medium (standard)	6.5 N/mm (37.1 lb/in)	
Fork length	913 mm (35.94 in)	
Fork oil per fork leg	640 ml (21.64 fl. oz.)	Fork oil (SAE 4) (48601166S1) (📖 p. 171)

23.8 Shock absorber

Shock absorber article number	15.18.7U.25	
Shock absorber	WP Suspension XPLOR 5746	
Low-speed compression damping		
Comfort	21 clicks	
Standard	15 clicks	
Sport	10 clicks	
Full payload	7 clicks	
High-speed compression damping		
Comfort	1.5 turns	
Standard	1.5 turns	
Sport	1 turn	
Full payload	1 turn	
Rebound damping		
Comfort	21 clicks	
Standard	15 clicks	
Sport	10 clicks	
Full payload	7 clicks	
Preload adjuster		
Standard Street	5 turns	
Standard Offroad	1 turn	
Full payload	26 turns	
Spring preload		
Standard Street	13 mm (0.51 in)	
Standard Offroad	10 mm (0.39 in)	
Full payload	19 mm (0.75 in)	
Spring rate		
Medium (standard)	160 N/mm (914 lb/in)	
Spring length	198.5 mm (7.815 in)	
Gas pressure	10 bar (145 psi)	
Static sag	25 mm (0.98 in)	
Riding sag	54 mm (2.13 in)	
Fitted length	388 mm (15.28 in)	
Shock absorber fluid (📖 p. 171)	SAE 2.5	

23.9 Chassis tightening torques

Cover, brake reservoir, rear		3.5 Nm (2.58 lbf ft)
Radiator hose clamp		2.4 Nm (1.77 lbf ft)
Screw, ball-head headlight holder	EJOT Altracs 5151[®] 50x12	7 Nm (5.2 lbf ft)
Screw, front brake reservoir cover		1 Nm (0.7 lbf ft)
Screw, oil filler neck on frame	EJOT PT[®] 50x14	2.8 Nm (2.07 lbf ft)
Screw, tail light	EJOT PT[®] K40x18	2 Nm (1.5 lbf ft)
Sleeve nut, fuel level sensor		15 Nm (11.1 lbf ft)
Screw, center headlight cover	M4x8	0.7 Nm (0.52 lbf ft)
Screw, fixed grip, left	M4x12	3 Nm (2.2 lbf ft)
Screw, license plate lamp	M4	0.5 Nm (0.37 lbf ft)
Screw, side stand sensor	M4x12 – 8.8	2 Nm (1.5 lbf ft)
		Loctite[®]243[™]
Spoke nipple	M4.5	5 Nm (3.7 lbf ft)
Remaining nuts, chassis	M5	5 Nm (3.7 lbf ft)
Remaining screws, chassis	M5	5 Nm (3.7 lbf ft)
Screw, brake hose bracket	M5	2 Nm (1.5 lbf ft)
Screw, brake line guide / cable bracket on swingarm	M5x10	5 Nm (3.7 lbf ft)
Screw, brake reservoir, rear brake	M5	3.5 Nm (2.58 lbf ft)
		Loctite[®]243[™]
Screw, chain sliding guard	M5x10	5 Nm (3.7 lbf ft)
Screw, combination switch, left	M5	5 Nm (3.7 lbf ft)
Screw, combination switch, right	M5	5 Nm (3.7 lbf ft)
Screw, connector support, fuel tank bracket	M5x10	3.5 Nm (2.58 lbf ft)
Screw, coolant compensating tank	M5x12	3.5 Nm (2.58 lbf ft)
Screw, cover part	M5x12	3.5 Nm (2.58 lbf ft)
Screw, dash	M5x8	1 Nm (0.7 lbf ft)
Screw, front tank protector	M5x22	2.5 Nm (1.84 lbf ft)
Screw, fuel tank cap	M5x25	3 Nm (2.2 lbf ft)
		Loctite[®]243[™]
Screw, headlight adjuster	M5x14	3.5 Nm (2.58 lbf ft)
Screw, headlight mask	M5x12	3.5 Nm (2.58 lbf ft)
Screw, heat shield on silencer	M5x14	5 Nm (3.7 lbf ft)
Screw, instrument support	M5x12	3.5 Nm (2.58 lbf ft)
Screw, light control unit bracket	M5x12	3.5 Nm (2.58 lbf ft)
Screw, mask support	M5x12	3.5 Nm (2.58 lbf ft)
Screw, radiator cover	M5x12	2.5 Nm (1.84 lbf ft)
Screw, radiator linkage bracket	M5x10	2.8 Nm (2.07 lbf ft)
Screw, rear brake lever stub	M5x16	5 Nm (3.7 lbf ft)
		Loctite[®]243[™]
Screw, rear cellphone storage compartment	M5x12	3.5 Nm (2.58 lbf ft)
Screw, rear tank protector, long	M5x17	3 Nm (2.2 lbf ft)
Screw, rear tank protector, short	M5x12	3 Nm (2.2 lbf ft)

Screw, sliding seat, windshield bushing	M5x20	4 Nm (3 lbf ft)	
Screw, splash protection, tail end lower part	M5x12	3 Nm (2.2 lbf ft)	
Screw, throttle	M5x25	3.5 Nm (2.58 lbf ft)	
Screw, top mask spoiler, fuel tank fairing	M5x12	2.5 Nm (1.84 lbf ft)	
Screw, windshield	M5x14	3.5 Nm (2.58 lbf ft)	
Screw, wiring harness cable guide	M5x12	5 Nm (3.7 lbf ft)	
Tire air pressure sensor (SUPER ADVENTURE R EU/CN)	M5x15	2.4 Nm (1.77 lbf ft)	
Clamp, header/silencer	M6	10 Nm (7.4 lbf ft)	
Ground fitting on frame	M6x16	6 Nm (4.4 lbf ft)	
Nut, windshield holder on sliding seat shaft	M6	5 Nm (3.7 lbf ft)	
Remaining nuts, chassis	M6	10 Nm (7.4 lbf ft)	
Remaining screws, chassis	M6	10 Nm (7.4 lbf ft)	
Screw, 6-D sensor	M6x15	6 Nm (4.4 lbf ft)	Loctite®243™
Screw, 6-D sensor retaining bracket	M6x16	10 Nm (7.4 lbf ft)	
Screw, ABS modulator fastening	M6x16	8 Nm (5.9 lbf ft)	
Screw, ball joint of push rod on foot brake cylinder	M6	10 Nm (7.4 lbf ft)	Loctite®243™
Screw, battery terminal	M6x12	4.5 Nm (3.32 lbf ft)	
Screw, bottom triple clamp cover	M6x12	6 Nm (4.4 lbf ft)	
Screw, brake assembly	M6	5 Nm (3.7 lbf ft)	
Screw, clutch lever assembly	M6x25	5 Nm (3.7 lbf ft)	
Screw, dash support	M6x18	10 Nm (7.4 lbf ft)	Loctite®243™
Screw, front brake disc	M6	14 Nm (10.3 lbf ft)	Loctite®243™
Screw, front cellphone storage compartment	M6x14	6 Nm (4.4 lbf ft)	
Screw, front sprocket cover	M6x25	9 Nm (6.6 lbf ft)	
Screw, front wheel speed sensor	M6x16	8 Nm (5.9 lbf ft)	
Screw, fuel petcock	M6x12	6 Nm (4.4 lbf ft)	
Screw, fuel pump	M6x16	6 Nm (4.4 lbf ft)	
Screw, fuel tank on carrier, long	M6x15	6 Nm (4.4 lbf ft)	
Screw, fuel tank on carrier, short	M6x12	6 Nm (4.4 lbf ft)	
Screw, header clamp, rear	M6x25	8 Nm (5.9 lbf ft)	
Screw, headlight on mask support	M6x20	8 Nm (5.9 lbf ft)	
Screw, rear brake disc	M6	14 Nm (10.3 lbf ft)	Loctite®243™
Screw, rear cover	M6x16	6 Nm (4.4 lbf ft)	
Screw, rear master cylinder	M6x25	10 Nm (7.4 lbf ft)	Loctite®243™
Screw, rear wheel speed sensor	M6x16	8 Nm (5.9 lbf ft)	

Screw, starter relay cable	M6x12	6 Nm (4.4 lbf ft)
Screw, tank mask spoiler	M6x12	6 Nm (4.4 lbf ft)
Screw, voltage regulator	M6x25	6 Nm (4.4 lbf ft)
Remaining nuts, chassis	M8	25 Nm (18.4 lbf ft)
Remaining screws, chassis	M8	25 Nm (18.4 lbf ft)
Screw, bottom triple clamp	M8x35	15 Nm (11.1 lbf ft)
Screw, engine brace on frame	M8x20	25 Nm (18.4 lbf ft) Loctite®243™
Screw, footrest bracket, rear	M8x25	25 Nm (18.4 lbf ft) Loctite®243™
Screw, fork shoe	M8x20	15 Nm (11.1 lbf ft)
Screw, front footrest bracket	M8x20	25 Nm (18.4 lbf ft) Loctite®243™
Screw, handle bar end hand guard	M8x40	25 Nm (18.4 lbf ft)
Screw, handlebar clamp	M8x25	20 Nm (14.8 lbf ft)
Screw, ignition lock (tamper-proof screw)	M8	25 Nm (18.4 lbf ft) Loctite®243™
Screw, side stand bracket on engine	M8x25	25 Nm (18.4 lbf ft) Loctite®243™
Screw, stand spring pin	M8	15 Nm (11.1 lbf ft)
Screw, steering damper on frame	M8x20	25 Nm (18.4 lbf ft) Loctite®243™
Screw, steering damper on triple clamp	M8x25	25 Nm (18.4 lbf ft) Loctite®243™
Screw, steering stem clamp	M8x35	20 Nm (14.8 lbf ft)
Screw, top case carrier	M8x40	25 Nm (18.4 lbf ft)
Screw, top triple clamp	M8x35	20 Nm (14.8 lbf ft)
Screw, fuel tank rubber support	M8x1.25	20 Nm (14.8 lbf ft)
Remaining nuts, chassis	M10	45 Nm (33.2 lbf ft)
Remaining screws, chassis	M10	45 Nm (33.2 lbf ft)
Screw, engine brace on frame	M10x50	45 Nm (33.2 lbf ft) Loctite®243™
Screw, handlebar mount	M10x35	40 Nm (29.5 lbf ft) Loctite®243™
Screw, rear brake lever	M10x35	25 Nm (18.4 lbf ft) Loctite®243™
Screw, side stand	M10	40 Nm (29.5 lbf ft) Loctite®243™
Screw, side stand bracket on console	M10x30	55 Nm (40.6 lbf ft) Loctite®243™
Screw, subframe	M10x20	45 Nm (33.2 lbf ft)
Banjo bolt, brake line	M10x1	25 Nm (18.4 lbf ft)
Nut, rear sprocket screw	M10x1.25	50 Nm (36.9 lbf ft) Loctite®243™
Nut, turn signal	M10x1.25	4 Nm (3 lbf ft)
Screw, front brake caliper	M10x1.5x55	45 Nm (33.2 lbf ft) Loctite®243™
Lambda sensor	M12x1.25	25 Nm (18.4 lbf ft)

23 TECHNICAL DATA

Screw, bottom shock absorber	M14x1.5	80 Nm (59 lbf ft) Thread greased
Screw, top shock absorber	M14x1.5	80 Nm (59 lbf ft) Thread greased
Nut, socket	M18x1	4 Nm (3 lbf ft)
Nut, fork pivot	M19x1.5	130 Nm (95.9 lbf ft) Thread greased
Screw, steering head, top	M22x1.5	18 Nm (13.3 lbf ft)
Nut, rear wheel spindle	M25x1.5	90 Nm (66.4 lbf ft) Thread greased
Screw, front wheel spindle	M25x1.5	45 Nm (33.2 lbf ft) Thread greased

24.1 Declarations of conformity

Info

The functional and equipment scope is model-dependent and may not include all wireless systems and application areas referred to.

KTM AG hereby declares that the **KTM RACE ON system** wireless system conforms with the relevant guidelines. The full text of the Declaration of Conformity is available at the following Internet address.

Certification website: <http://www.ktm.com/ktm-race-on>

Polaris hereby declares that the **Connectivity Control Unit "CCU-2"** wireless system conforms with the relevant guidelines. The full text of the Declaration of Conformity is available at the following Internet address.



Certification website: <http://www.ktm.com/ccu-2>

LDL Technology hereby declares that the **Tyre Pressure Monitoring System** wireless system conforms with the relevant guidelines. The full text of the Declaration of Conformity is available at the following Internet address.

Certification website: <http://www.ktm.com/tpms>

24.2 Country-specific declarations of conformity (KTM RACE ON system 1)

KTM RACE ON system

Complies with
IMDA Standards
N0336-20

Complies with
IMDA Standards
N0337-20





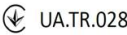

TRA REGISTERED No: ER78448/20 DEALER No: DAB3368/19	TRA REGISTERED No: ER78449/20 DEALER No: DAB3368/19	Equipment Name: 미약전계강도 무선기기 Registration No. R-R-AD1-CL9 Equipment Name: 특정소출력 무선기기(데이터전송용 무선기기) Registration No. R-C-AD1-CL9-904	מספר אישור אלחוטני של משרד התקשורת הוא 51-72522 אסור להחליף את האנטנה המקורית של המכשיר ולא לעשות בו כל שינוי טכני אחר
---	---	--	---

AGRÉÉ PAR L'ANRT MAROC Numéro d'agrément: MR 22310 ANRT 2020	51-72620 מספר אישור אלחוטני של משרד התקשורת הוא אסור להחליף את האנטנה המקורית של המכשיר ולא לעשות בו כל שינוי טכני אחר
---	---



Product name	Steering lock	Smart key
IC	6505A-CL9	6505A-CL9904

Model:CL9-904 01894-20-05543  Model:CL9 01893-20-05543 	"Este produto está homologado pela ANATEL, de acordo com os procedimentos regulamentados pela Resolução 242/2000, e atende aos requisitos técnicos aplicados". Para maiores informações, consulte o site da ANATEL www.anatel.gov.br Este equipamento não tem direito à proteção contra interferência prejudicial e não pode causar interferência em sistemas devidamente autorizados.
--	---

E02298-01

24.3 Country-specific declarations of conformity (KTM RACE ON system 2)

KTM RACE ON system

La operación de este equipo está sujeta a las siguientes dos condiciones: (1) es posible que este equipo o dispositivo no cause interferencia perjudicial y (2) este equipo o dispositivo debe aceptar cualquier interferencia, incluyendo la que pueda causar su operación no deseada.

Product name	Steering lock	Smart key
Model	CL9	CL9-904
Certification No.	IFETEL: RLVASCL20-0474	IFETEL: RLVASCL20-0473

This product contains radio equipment (134 kHz transmitter) which is conform with the regulations for communications equipment (extremely low-power radio station) specified in article 6, paragraph 1 of the Radio Law Enforcement Regulations.



CNC COMISIÓN NACIONAL DE COMUNICACIONES
H-24465





CNC COMISIÓN NACIONAL DE COMUNICACIONES
H-24464

Product name	Steering lock	Smart key
FCC ID	T8VCL9	T8VCL9-904

This device complies with part 15 of the FCC Rules. Operation is subject to the following two conditions: (1) This device may not cause harmful interference, and (2) this device must accept any interference received, including interference that may cause undesired operation.

FCC CAUTION
Changes or modifications not expressly approved by the party responsible for compliance could void the user's authority to operate the equipment.

不得擅自改变使用场景或使用条件、扩大发射频率范围、加大发射功率（包括额外加装射频功率放大器），不得擅自更改发射天线；
不得对其他合法的无线电台（站）产生有害干扰，也不得提出免受有害干扰保护；
应当承受射频频率能量的工业、科学及医疗（ISM）应用设备的干扰或其他合法的无线电台（站）干扰；
知对其他合法的无线电台（站）产生有害干扰时，应立即停止使用，并采取措施消除干扰后方可继续使用；
在航空器内和依据法律法规、国家标准设的射电天文台、气象雷达站、卫星地球站（含测控、测距、接收、导航站）等军民用无线电台（站）、机场等的电磁环境保护区域内使用微功率设备，应当遵守电磁环境保护及相关行业主管部门的规定；
禁止在以机场跑道中心点为圆心、半径 5000 米的区域内使用各类模型遥控器；

低功率電波輻射性電機管理辦法 第十條

第十二條
輕型式認證合格之低功率射頻電機，非經許可，公司、商號或使用者均不得擅自變更頻率、加大功率或變更原設計之特性及功能。

第十四條
低功率射頻電機之使用不得影響飛航安全及干擾合法通信。經發現有干擾現象時，應立即停用，並改善至無干擾時方得繼續使用。
前項合法通信，指依電信法規定作業之無線電通信。
低功率射頻電機須忍受合法通信或工業、科學及醫療用電流輻射性電機設備之干擾。

เครื่องโทรคมนาคมและอุปกรณ์นี้ มีความสอดคล้องตามมาตรฐานหรือข้อกำหนดทางเทคนิคของ nttc.

E02326-01

24.4 Country-specific declarations of conformity (CCU-2)

FC CONTAINS FCC ID: 2A0W7-K001
CONTAINS IC: 5966A-K001
CMIIT ID: XXXXXXXXX

ANATEL 04624-20-12908

CCA J20LP09A0T1
CNC ID: C-24749

UA.032.CT.0103-20
AGREE PAR L'ANRT MAROC
Numéro d'agrément: MR22163 ANRT 2020
Date d'agrément: 25/02/2020

TRAIL TECH
Polaris Industries Inc.
Connectivity Control Unit
Model: CCU-2
Country of Origin: USA
Input: 14VDC/1.1A

R-C-1PR-CCU

NOM Polaris Industries
Unidad de control de comunicaciones
Trail Tech
CCU-2
INPUT: 14Vcc 1.1A
USA
IFT #: RCPTRCC20-0716

TP BY

Complies with
IMDA Standards
DA107035

EAC **CE**

R-NZ

TRA
REGISTERED No:
ER79816/20
DEALER No:
DA68241/17

ICASA TA-2020/5195
APPROVED

Certified for use in Hong Kong
經驗證可在香港使用
Certificate No. 證書號碼
HK0012002210

COMUNICATIONS AUTHORITY

nantb.

เครื่องวิทยุคมนาคมนี้ ได้รับยกเว้น ไม่ต้องได้รับใบอนุญาตให้มี ใช้ซึ่งเครื่องวิทยุคมนาคมหรือตั้งสถานีวิทยุคมนาคมตามประกาศ กสทช. เรื่อง เครื่องวิทยุคมนาคม และสถานีวิทยุคมนาคมที่ได้รับยกเว้นไม่ต้องได้รับใบอนุญาตวิทยุคมนาคมตามพระราชบัญญัติวิทยุคมนาคม พ.ศ. 2498



nantb. | โทรคมนาคม
กำกับดูแลเพื่อประชาชน
Call Center 1200 (InSWS)

E02299-01

168

25.1 Information on open source software

Some vehicle components use open source software.

The source code of the software used and other information are available online.

Overview: <http://www.ktm.com/ktm-oss>

Info

Due to the file size, the download may take a long time.

Depending on the Internet provider, costs may arise due to the data volume.

Brake fluid DOT 4 / DOT 5.1

Standard/classification

- DOT

Guideline

- Use only brake fluid that complies with the specified standard (see specifications on the container) and that exhibits the corresponding properties.

Recommended supplier

Castrol

- REACT PERFORMANCE DOT 4

MOTOREX®

- Brake Fluid DOT 5.1

Coolant

Guideline

- Only use high-grade, silicate-free coolant with corrosion inhibitor additive for aluminum motors. Low grade and unsuitable antifreeze causes corrosion, deposits and frothing.
- Do not use pure water as only coolant is able to meet the requirements needed in terms of corrosion protection and lubrication properties.
- Only use coolant that complies with the requirements stated (see specifications on the container) and that has the relevant properties.

Antifreeze protection to at least	-25 °C (-13 °F)
-----------------------------------	-----------------

The mixture ratio must be adjusted to the necessary antifreeze protection. Use distilled water if the coolant needs to be diluted.

The use of premixed coolant is recommended.

Observe the coolant manufacturer specifications for antifreeze protection, dilution and miscibility (compatibility) with other coolants.

Recommended supplier

MOTOREX®

- COOLANT M3.0

Engine oil (SAE 10W/50)

Standard/classification

- JASO T903 MA2 (📖 p. 173)
- SAE (📖 p. 173) (SAE 10W/50)

Guideline

- Use only engine oils that comply with the specified standards (see specifications on the container) and that possess the corresponding properties.

Fully synthetic engine oil

Recommended supplier

MOTOREX®

- Power Synt 4T

Engine oil (SAE 5W/40)**Standard/classification**

- JASO T903 MA2 (📖 p. 173)
- SAE (📖 p. 173) (SAE 5W/40)

Guideline

- Use only engine oils that comply with the specified standards (see specifications on the container) and that possess the corresponding properties.

Fully synthetic engine oil

Recommended supplier**MOTOREX®**

- Power Synt 4T

Fork oil (SAE 4) (48601166S1)**Standard/classification**

- SAE (📖 p. 173) (SAE 4)

Guideline

- Use only oils that comply with the specified standards (see specifications on the container) and that exhibit the corresponding properties.

Shock absorber fluid (SAE 2.5) (50180751S1)**Standard/classification**

- SAE (📖 p. 173) (SAE 2.5)

Guideline

- Use only oils that comply with the specified standards (see specifications on the container) and that exhibit the corresponding properties.

Super unleaded (ROZ 95)**Standard/classification**

- DIN EN 228 (ROZ 95)

Guideline

- Only use super unleaded fuel that matches or is equivalent to the specified standard.
- Fuel with an ethanol content of up to 10% (E10 fuel) is safe to use.

**Info**

Do **not** use fuel containing methanol (e.g., M15, M85, M100) or more than 10% ethanol (e.g., E15, E25, E85, E100).

Chain cleaner

Recommended supplier
MOTOREX®
– Chain Clean

Fuel additive

Recommended supplier
MOTOREX®
– Fuel Stabilizer

Long-life grease

Recommended supplier
MOTOREX®
– Bike Grease 2000

Motorcycle cleaner

Recommended supplier
MOTOREX®
– Moto Clean

Perfect finish and high gloss polish for paints

Recommended supplier
MOTOREX®
– Moto Shine

Preserving materials for paints, metal and rubber

Recommended supplier
MOTOREX®
– Moto Protect

Special cleaner for glossy and matte paint finishes, metal and plastic surfaces

Recommended supplier
MOTOREX®
– Quick Cleaner

Street chain spray

Guideline
Recommended supplier
MOTOREX®
– Chainlube Road Strong

Universal oil spray

Recommended supplier
MOTOREX®
– Joker 440 Synthetic

JASO T903 MA2

Different technical development directions required a separate specification for motorcycles – the **JASO T903 MA2** standard.

Earlier, engine oils from the automobile industry were used for motorcycles because there was no separate motorcycle specification.

Whereas long service intervals are demanded for automobile engines, the focus for motorcycle engines is on high performance at high engine speeds.

In most motorcycle engines, the transmission and clutch are lubricated with the same oil.

The **JASO T903 MA2** standard meets these special requirements.

SAE

The SAE viscosity classes were defined by the Society of Automotive Engineers and are used for classifying oils according to their viscosity. The viscosity describes only one property of oil and says nothing about quality.

ABS	Anti-lock braking system	Safety system that prevents locking of the wheels when driving straight ahead without the influence of lateral forces
ARA	Anti-relay attack	Safety system that deactivates the wireless response of the RACE ON key after a certain time and thus increases security against theft
ATIR	Automatic Turn Indicator Reset	Software, which automatically switches the indicator off according to a time or travel distance counter
DRL	Daytime Running Light	Light, which enhances the visibility of the vehicle during the day but is not focused, and in contrast to low beam does not illuminate the road surface
ETTC	Engine traction torque control	Auxiliary function of the engine control, which prevents rear wheel locking with excessive engine braking effect, by lightly opening the throttle valve
HHC	Hill Hold Control	Assist, which prevents the vehicle from rolling backwards on an incline
-	KTM RACE ON	System that releases the ignition, steering lock, and fuel tank filler cap via a remote key with a transponder
MSC	Motorcycle stability control	This is an auxiliary function for the ABS, which can prevent locking and slipping of the wheels during braking while leaning at an angle, within physical limitations
MTC	Motorcycle Traction Control	Auxiliary function of the motor control that reduces engine torque with spinning rear wheel
OBD	On-board diagnosis	Vehicle system, which monitors the specified parameters of the vehicle electronics
-	Quickshifter +	Engine electronics function for shifting up and down without clutch actuation

Art. no.	Article number
ca.	circa
cf.	compare
e.g.	for example
etc.	et cetera
i.a.	inter alia
no.	number
poss.	possibly







31.1 Red symbols

Red symbols indicate an error condition that requires immediate intervention.

	<p>The oil pressure warning lamp lights up red – The oil pressure is too low. Stop immediately, taking care not to endanger yourself or other road users in the process, and switch off the engine.</p>
---	---





31.2 Yellow and orange symbols

Yellow and orange symbols indicate an error condition that requires prompt intervention. Active driving aids are also represented by yellow or orange symbols.

	<p>RACE-ON indicator light lights up/flashes yellow/orange/red – Status or error messages relating to KTM RACE ON system/alarm system.</p>
	<p>The general warning lamp lights up yellow – A note/warning note on operating safety has been detected. This is also shown in the display.</p>
	<p>The ABS warning lamp lights up yellow – Status or error messages relating to ABS. The ABS warning lamp flashes if the ABS mode Offroad is enabled.</p>
	<p>TC indicator lamp lights up/flashes yellow – The MTC (📖 p. 143) is not enabled or is currently intervening. The TC indicator lamp also lights up if a malfunction is detected. Contact an authorized KTM workshop. The TC indicator lamp flashes if TC actively engages or if the HHC (📖 p. 74) (optional) is activated.</p>
	<p>The cruise control system indicator lamp lights up yellow – The cruise control system function is switched on, but cruise control is not activated.</p>
	<p>Malfunction indicator lamp lights up yellow – The OBD has detected a malfunction in the vehicle electronics.</p>

31.3 Green and blue symbols

Green and blue symbols reflect information.

	<p>The left turn signal indicator light flashes green with a steady rhythmic flash – The left turn signal is switched on.</p>
	<p>The high beam indicator light lights up blue – The high beam is switched on.</p>
	<p>Neutral position indicator is active in the display – The transmission is in the neutral position.</p>
	<p>The cruise control system indicator lamp lights up green – The cruise control system function is switched on and cruise control is activated.</p>
	<p>The right turn signal indicator lamp flashes green with a steady rhythmic flash – The right turn signal is switched on.</p>

+	
+RES/-SET button	
operation	18
1	
12 V battery	
charging	133
installing	132
removing	131
A	
ABS	113
Accessories	10
Accessories circuit 1	
front	139
rear	140
Accessories circuit 2	
front	139
rear	140
Anti-lock braking system	113
anti-relay attack	22
ARA	22
Auxiliary substances	10
B	
Brake discs	
checking	114
Brake fluid	
of front brake, adding	116
of rear brake, adding	118
Brake fluid level	
front brake, checking	115
rear brake, checking	117
Brake linings	
front brake, checking	117
rear brake, checking	119
Brake system	113-120
Brakes	78
Braking	78
C	
C1 and C2 switch	20
Capacity	
coolant	159
engine oil	147, 159
fuel	81, 160
Center stand	28
Chain	
checking	93
checking for dirt	90
cleaning	90
Chain tension	
adjusting	92
checking	91
Clutch	
fluid level, checking/correcting	94
Clutch lever	15
basic position, adjusting	63
Combination instrument	29-61
Anti Relay Attack	53
Bike Info	44
Bluetooth	54
Button Illumination	53
Clock & Date	56
Clock Format	56
Custom Switch	50
Date Format	56
Display Theme	53
DRL	53
Extra Functions	59
Favourites	51
Favourites indicator 1-4	51
Hill Hold Control (optional)	54
indicator lamps	32
menu	39
overview	29
Quickshifter + (optional)	54
Settings Heating	58
Settings Heating Grips	58
Settings Heating Pillion Seat	58
Settings Heating Rider Seat	58
Shift Light	54
Shift Light RPM1	55
Shift Light RPM2	55
Shift Light State	55
Taste C1 und C2	51
TPMS Setting	52
Units	56
Units Consumption	57
Units Distance	57
Units Pressure	57
Units Temperature	57
Combination switch	
left side	15
overview left side	15
overview right	19
right	19
Coolant level	
checking in the compensating tank	141
correcting in the compensating tank	141
Cornering light	131
Crash bar	
installing	111

removing	110	Date	
Cruise control		adjusting	59
indicator	36	Daytime running light	130
operation	16	Declarations of conformity	167-168
Customer service	10	country-specific	167-168
		country-specific (CCU-2)	168
D		Diagnostics connector	139
Dash		DRL	130
ABS	48	E	
ABS display	36	Emergency OFF switch	20
activation and test	29	Emergency seat release	26
adjusting tilt	68	Engine	
Audio	43	running in	70
Bike Info	44	Engine guard	
Call display	39	installing	108
coolant temperature indicator	37	removing	108
cruise control indicator	36	Engine number	13
day-night mode	30	Engine oil	
display	33	adding	148
display Rally (optional)	34	changing	145
engine speed	35	Engine oil level	
Favourites display	38	checking	145
fuel level display	38	Engine sprocket	
Headset Type	41	checking	93
heated grip (optional)	37	Engine traction torque control	77
Heating (function optional)	60	Environment	9
Heating Grips (function optional)	61	F	
Heating Rider Seat (function optional)	61	Figures	10
ice warning	31	Foot brake lever	27
KTM MY RIDE	39	basic position, adjusting	67
Motorcycle	46	Footrests	
MTC	47	adjusting	64
MTC display	36	Fork	84
MTC+MSR (optional)	47	compression damping, adjusting	84
Navigation (optional)	42	dust boots, cleaning	110
navigation volume	42	rebound, adjusting	85
Navigation display	38	spring preload, adjusting	85
Phone	40	Fork part number	13
Ride Mode	46, 143	Front fender	
Ride-Mode display	37	installing	109
Rider's Headset	41	removing	109
seat heating (optional)	37	Front side fairing	
Settings	50	installing	103
shift light	35	removing	102
Slip Adjuster (optional)	144	Front wheel	
Slip Adjuster (optional)	49	installing	122
speed	36	removing	121
Throttle Response (optional)	49, 144	Fuel petcocks	24
Trip	45		
Trip 1	45		
Trip 2	45		
warnings	31		

Fuel tank fairing		
installing	99-100	
removing	98-99	
Fuel tank filler cap		
closing	24	
opening	23	
Fuel, oils, etc.	10	
Fuses		
in fuse box, changing	137	
G		
Grab handles	26	
H		
Hand brake lever		
basic position, adjusting	63	
Handbrake lever	15	
Handlebar position	62	
adjusting	62	
Hazard warning flasher	19	
Hazard warning flasher switch	19	
Headlight		
cornering light	131	
daytime running light	130	
high beam	130	
low beam	130	
range, adjusting	139	
Headlight setting		
checking	138	
High beam	130	
Horn button	19	
I		
Ice warning	31	
Immobilizer	21	
Implied warranty	10	
Indicator lamps	32	
Intended use	7	
L		
Light switch	16	
Low beam	130	
Luggage	70	
Luggage rack plate	26	
M		
Main fuse		
changing	136	
Manufacturer warranty	10	
Mask spoiler		
installing	106	
removing	104	
Misuse	7	
Motorcycle		
cleaning	150	
Motorcycle traction control	143	
MSR	77	
MTC	143	
O		
Oil filler neck cover		
installing	109	
removing	109	
Oil filter		
changing	145	
Oil screens		
cleaning	145	
Open source		
information	169	
Open source		
information	169	
Owner's Manual	9	
P		
Parking	79	
Passenger foot pegs	27	
Preparing for use		
advice on preparing for first use	69	
after storage	153	
checks and maintenance measures when		
preparing for use	72	
Protective clothing	9	
Q		
Quickshifter +	74	
R		
RACE ON button	20	
RACE ON key	21	
anti-relay attack	22	
RACE-ON key battery, changing	135	
Rear hub damping rubber pieces		
checking	126	
Rear sprocket		
checking	93	
Rear wheel		
installing	124	
removing	123	
Refueling		
fuel	80	
Rider footrests	64	
Riding	75	
starting off	74	

starting with HHC (optional)	74		
S		T	
Safe operation	8	Technical data	
Seat		capacities	159
emergency release	26	chassis	160
mounting	90	chassis tightening torques	163
removing	89	electrical system	161
unlocking	26	engine	156-166
Seat release	26	engine tightening torques	157
Service	10	fork	161
Service schedule	82-83	shock absorber	162
Shift lever	27	tires	161
basic position, adjusting	66	Throttle grip	15
basic position, checking	65	Time	
Shift lever stub		adjusting	59
adjusting	67	Tire air pressure monitoring system	
Shifting	75	setting	52
Shock absorber	84	Tire condition	
Compression damping	86	checking	127
high-speed compression damping, adjusting	87	Tire pressure	
low-speed compression damping, adjusting	86	checking	128
rebound damping, adjusting	88	Tire repair spray	
spring preload, adjusting	88	using	129
Shock absorber article number	14	TPMS	
Side spoiler		setting	52
installing	102	Transporting	80
removing	101	Triple clamp cover, bottom	
Side stand	28	installing	96
Socket for electrical accessories	23	removing	96
Spare parts	10	Troubleshooting	154-155
Spoke tension		Turn signal switch	18
checking	128	Type label	13
Start button	20	U	
Starting	72	USB socket	23
Steering damper article number	14	Use definition	7
Steering head bearing play		V	
checking	95	Vehicle	
Steering lock	21	loading	70
Stopping	79	raising with the center stand	89
Storage	153	removing from the center stand	89
Storage compartment		Vehicle identification number	13
closing	25	View of vehicle	
installing	98	front left	11
opening	25	rear right	12
removing	97	W	
USB socket	23	Windshield	
Suspension setting	84-88	adjusting	63
		installing	97
		removing	96

Winter operation	
checks and maintenance steps	151
Work rules	9



3214297en

01/2021

