

**85 SX**

ART. NO. 3214408EN





Congratulations on your decision to purchase a KTM motorcycle. You are now the owner of a state-of-the-art, sporty motorcycle that will continue to give you and your child pleasure for a long time if you maintain it properly.

We hope your child has many safe and enjoyable rides!

Enter the serial numbers of your vehicle below.

Vehicle identification number (📖 p. 12)	Dealer's stamp
Engine number (📖 p. 12)	

The Owner's Manual contained the latest information for this model series at the time of publication. However, minor differences due to further developments in design cannot be ruled out completely.

All specifications contained herein are non-binding. KTM Sportmotorcycle GmbH specifically reserves the right to modify or delete technical specifications, prices, colors, forms, materials, services, designs, equipment, etc., without prior notice and without specifying reasons, to adapt these to local conditions, as well as to stop production of a particular model without prior notice. KTM accepts no liability for delivery options, deviations from figures and descriptions, misprints, and other errors. The models portrayed partly contain special equipment that does not belong to the regular scope of supply.

© 2022 KTM Sportmotorcycle GmbH, Mattighofen Austria

All rights reserved

Reproduction, even in part, as well as copying of all kinds, is permitted only with the express written permission of the copyright owner.



ISO 9001(12 100 6061)

KTM applies quality assurance processes that lead to the highest possible product quality as defined in the ISO 9001 international quality management standard.

Issued by: TÜV-Management Service

REG.NO. 12 100 6061

KTM Sportmotorcycle GmbH  
Stallhofnerstraße 3  
5230 Mattighofen, Austria

This document is valid for the following models:































85 SX 19/16 (F6001V9)







85 SX 17/14 (F6001V8)



# TABLE OF CONTENTS

1	MEANS OF REPRESENTATION .....	5	7.2	Running in the engine .....	21
1.1	Symbols used .....	5	7.3	Preparing the vehicle for difficult operating conditions.....	21
1.2	Formats used.....	5	7.4	Preparing the vehicle for riding on dry sand.....	21
2	SAFETY ADVICE.....	6	7.5	Preparing the vehicle for riding on wet sand .....	23
2.1	Use definition – intended use.....	6	7.6	Preparing vehicle for rides on wet and muddy circuits .....	23
2.2	Misuse.....	6	7.7	Preparing vehicle for high temperatures or slow riding.....	24
2.3	Safety advice.....	6	7.8	Preparing the vehicle for low temperatures or snow .....	25
2.4	Degrees of risk and symbols.....	6	8	RIDING INSTRUCTIONS.....	26
2.5	Tampering warning.....	7	8.1	Checks and maintenance measures when preparing for use .....	26
2.6	Safe operation .....	7	8.2	Starting the vehicle .....	26
2.7	Protective clothing .....	7	8.3	Starting off.....	27
2.8	Work rules.....	8	8.4	Shift, ride .....	27
2.9	Environment.....	8	8.5	Braking .....	28
2.10	Owner's Manual .....	8	8.6	Stopping, parking.....	28
3	IMPORTANT NOTES.....	9	8.7	Transporting.....	29
3.1	Manufacturer warranty, implied warranty.....	9	8.8	Refueling .....	29
3.2	Fuel, auxiliary substances .....	9	9	SERVICE SCHEDULE .....	31
3.3	Spare parts, accessories .....	9	9.1	Additional information .....	31
3.4	Service .....	9	9.2	Required work .....	31
3.5	Figures .....	9	9.3	Recommended work .....	32
3.6	Customer service.....	9	10	TUNING THE CHASSIS .....	33
4	VIEW OF VEHICLE .....	10	10.1	Checking the basic chassis setting with rider's weight.....	33
4.1	View of vehicle, front left (example) ...	10	10.2	Air suspension XACT 5543 .....	33
4.2	View of vehicle, rear right (example).....	11	10.3	Compression damping of the shock absorber.....	34
5	SERIAL NUMBERS .....	12	10.4	Adjusting the low-speed compression damping of the shock absorber.....	34
5.1	Vehicle identification number.....	12	10.5	Adjusting the high-speed compression damping of the shock absorber.....	35
5.2	Type label .....	12	10.6	Adjusting the rebound damping of the shock absorber.....	35
5.3	Engine number .....	12	10.7	Measuring the dimension of the rear wheel unloaded.....	36
5.4	Fork part number .....	12	10.8	Checking the static sag of the shock absorber.....	36
5.5	Shock absorber article number .....	13	10.9	Checking the riding sag of the shock absorber.....	37
6	CONTROLS.....	14	10.10	Adjusting the spring preload of the shock absorber ↘.....	37
6.1	Clutch lever.....	14	10.11	Adjusting the riding sag ↘.....	38
6.2	Hand brake lever.....	14	10.12	Checking the basic setting of the fork .....	39
6.3	Throttle grip .....	14	10.13	Adjusting the fork air pressure.....	39
6.4	Stop button .....	14			
6.5	Opening the fuel tank filler cap .....	15			
6.6	Closing the fuel tank filler cap.....	15			
6.7	Fuel tap .....	16			
6.8	Choke .....	16			
6.9	Shift lever .....	16			
6.10	Kick starter lever.....	17			
6.11	Foot brake lever .....	17			
6.12	Plug-in stand.....	17			
6.13	Service hour counter .....	18			
7	PREPARING FOR USE.....	19			
7.1	Advice on preparing for first use .....	19			

10.14	Adjusting the compression damping of the fork .....	41	11.38	Checking the link fork  .....	67
10.15	Adjusting the rebound damping of the fork .....	41	11.39	Checking the throttle cable routing ....	67
10.16	Handlebar position .....	42	11.40	Checking the rubber grip .....	68
10.17	Adjusting the handlebar position  .....	42	11.41	Adjusting the basic position of the clutch lever .....	68
11	SERVICE WORK ON THE CHASSIS .....	44	11.42	Checking the fluid level of the hydraulic clutch .....	69
11.1	Raising the motorcycle with a lift stand .....	44	11.43	Correcting the fluid level of the hydraulic clutch .....	69
11.2	Removing the motorcycle from the lift stand .....	44	11.44	Changing the hydraulic clutch fluid  .....	70
11.3	Bleeding the fork legs .....	44	12	BRAKE SYSTEM .....	72
11.4	Cleaning the dust boots of the fork legs .....	45	12.1	Checking the free travel of the hand brake lever .....	72
11.5	Removing the fork legs  .....	45	12.2	Adjusting the free travel of the handbrake lever .....	72
11.6	Installing the fork legs  .....	46	12.3	Checking the brake discs .....	72
11.7	Removing the fork protector .....	47	12.4	Checking the front brake fluid level ...	73
11.8	Installing the fork protector .....	47	12.5	Adding the front brake fluid  .....	74
11.9	Removing the lower triple clamp  .....	48	12.6	Checking the front brake linings .....	75
11.10	Installing the lower triple clamp  .....	49	12.7	Changing the brake linings of the front brake  .....	75
11.11	Checking the steering head bearing play .....	51	12.8	Checking the free travel of foot brake lever .....	78
11.12	Adjusting the steering head bearing play  .....	52	12.9	Adjusting the basic position of the foot brake lever  .....	78
11.13	Lubricating the steering head bearing  .....	53	12.10	Checking the rear brake fluid level .....	79
11.14	Removing the start number plate .....	53	12.11	Adding rear brake fluid  .....	79
11.15	Installing the start number plate .....	53	12.12	Checking the rear brake linings .....	80
11.16	Removing front fender .....	54	12.13	Changing the rear brake linings  .....	81
11.17	Installing front fender .....	54	13	WHEELS, TIRES .....	84
11.18	Removing the shock absorber  .....	54	13.1	Removing the front wheel  .....	84
11.19	Installing the shock absorber  .....	55	13.2	Installing the front wheel  .....	84
11.20	Removing the seat .....	55	13.3	Removing the rear wheel  .....	85
11.21	Mounting the seat .....	55	13.4	Installing the rear wheel  .....	86
11.22	Removing the air filter box cover .....	56	13.5	Checking the tire condition .....	87
11.23	Installing the air filter box cover .....	56	13.6	Checking tire pressure .....	88
11.24	Removing the air filter  .....	56	13.7	Checking spoke tension .....	88
11.25	Cleaning the air filter and air filter box  .....	57	14	COOLING SYSTEM .....	90
11.26	Installing the air filter  .....	57	14.1	Cooling system .....	90
11.27	Removing the main silencer .....	58	14.2	Radiator cover .....	90
11.28	Installing the main silencer .....	58	14.3	Installing the radiator cover .....	90
11.29	Changing the glass fiber yarn filling of the main silencer  .....	58	14.4	Removing the radiator cover .....	91
11.30	Removing the fuel tank  .....	59	14.5	Checking the antifreeze and coolant level .....	92
11.31	Installing the fuel tank  .....	61	14.6	Checking the coolant level .....	93
11.32	Checking for chain dirt accumulation .....	62	14.7	Draining the coolant  .....	93
11.33	Cleaning the chain .....	62	14.8	Refilling with coolant  .....	94
11.34	Checking the chain tension .....	63	14.9	Changing the coolant  .....	95
11.35	Adjusting the chain tension .....	64			
11.36	Checking the chain, rear sprocket, engine sprocket, and chain guide .....	65			
11.37	Checking the frame  .....	67			

15	TUNING THE ENGINE.....	97	INDEX.....	129
15.1	Checking the play in the throttle cable.....	97		
15.2	Adjusting the play in the throttle cable  .....	97		
15.3	Carburetor tuning.....	98		
15.4	Carburetor – idle setting.....	100		
15.5	Carburetor – adjusting the idle speed  .....	101		
15.6	Emptying the carburetor float chamber  .....	102		
15.7	Plug-in connector of ignition timing map adjustment.....	103		
15.8	Changing the ignition timing map....	103		
15.9	Checking the basic position of the shift lever.....	103		
15.10	Adjusting the basic position of the shift lever  .....	103		
16	SERVICE WORK ON THE ENGINE .....	105		
16.1	Checking the gear oil level .....	105		
16.2	Changing the gear oil  .....	105		
16.3	Adding the gear oil  .....	106		
17	CLEANING, CARE .....	108		
17.1	Cleaning the motorcycle .....	108		
18	STORAGE.....	110		
18.1	Storage .....	110		
18.2	Preparing for use after storage.....	111		
19	TROUBLESHOOTING .....	112		
20	TECHNICAL DATA.....	114		
20.1	Engine .....	114		
20.2	Engine tightening torques .....	114		
20.3	Carburetor.....	116		
20.3.1	Basic carburetor setting for sandy surfaces.....	116		
20.3.2	Carburetor tuning  .....	116		
20.4	Capacities .....	117		
20.4.1	Gear oil.....	117		
20.4.2	Coolant.....	117		
20.4.3	Fuel .....	117		
20.5	Chassis .....	117		
20.6	Tires.....	118		
20.7	Fork.....	118		
20.8	Shock absorber.....	119		
20.9	Chassis tightening torques .....	119		
21	SUBSTANCES .....	122		
22	AUXILIARY SUBSTANCES .....	124		
23	STANDARDS .....	126		
24	LIST OF ABBREVIATIONS.....	127		

## 1.1 Symbols used

The meaning of specific symbols is described below.



Indicates an expected reaction (e.g. of a work step or a function).



Indicates an unexpected reaction (e.g. of a work step or a function).



Indicates work that requires expert knowledge and technical understanding. In the interest of your own safety, have these jobs performed by an authorized KTM workshop! Your motorcycle will be cared for there to the highest degree by specially trained experts using the special tools required.



Indicates a page reference (more information is provided on the specified page).



Indicates information with more details or tips.



Indicates the result of a testing step.



Indicates a voltage measurement.



Indicates a current measurement.



Indicates the end of an activity, including potential rework.

## 1.2 Formats used

The typographical formats used in this document are explained below.

<b>Proprietary name</b>	Indicates a proprietary name.
<b>Name®</b>	Indicates a protected name.
<b>Brand™</b>	Indicates a brand available on the open market.
<b><u>Underlined terms</u></b>	Refer to technical details of the vehicle or indicate technical terms, which are explained in the glossary.

### 2.1 Use definition – intended use

This vehicle has been designed and built to withstand the normal stresses and strains of racing. This vehicle complies with the currently valid regulations and categories of the top international motorsports organizations.



#### Info

Only operate this vehicle in closed-off areas remote from public road traffic.

### 2.2 Misuse

The vehicle must only be used as intended.

Dangers can arise for people, property and the environment through use not as intended.

Any use of the vehicle beyond the intended and defined use constitutes misuse.

Misuse also includes the use of operating and auxiliary fluids which do not meet the required specification for the respective use.

### 2.3 Safety advice

A number of safety instructions need to be followed to operate the product described safely. Therefore read this instruction and all further instructions included carefully. The safety instructions are highlighted in the text and are referred to at the relevant passages.



#### Info

Various information and warning labels are attached in prominent locations on the product described. Do not remove any information or warning labels. If they are missing, you or others may not recognize dangers and may therefore be injured.

### 2.4 Degrees of risk and symbols



#### Danger

Identifies a danger that will immediately and invariably lead to fatal or serious permanent injury if the appropriate measures are not taken.



#### Warning

Identifies a danger that is likely to lead to fatal or serious injury if the appropriate measures are not taken.



#### Caution

Identifies a danger that may lead to minor injuries if the appropriate measures are not taken.

#### Note

Identifies a danger that will lead to considerable machine and material damage if the appropriate measures are not taken.



#### Note

Indicates a danger that will lead to environmental damage if the appropriate measures are not taken.



## 2.5 Tampering warning

Tampering with the noise control system is prohibited. Federal law prohibits the following acts or the causing thereof:

- 1 The removal or rendering inoperative by any person other than for purposes of servicing, repair, or replacement, of any device or element of design incorporated into any new vehicle for the purpose of noise control prior to its sale or delivery to the ultimate purchaser or while it is in use, or
- 2 the use of the vehicle after such device or element of design has been removed or rendered inoperative by any person.

Among those acts presumed to constitute tampering are the acts listed below:

- 1 Removal or puncturing of the main silencers, baffles, header pipes or any other components which conduct exhaust gases.
- 2 Removal or puncturing of parts of the intake system.
- 3 Lack of proper maintenance.
- 4 Replacing moving parts of the vehicle, or parts of the exhaust system or intake system, with parts other than those specified by the manufacturer.

## 2.6 Safe operation



### Danger

**Danger of accidents** A rider who is not fit to ride poses a danger to him or herself and others.

- Do not operate the vehicle if you are not fit to ride due to alcohol, drugs or medication.
- Do not operate the vehicle if you are physically or mentally impaired.



### Danger

**Danger of poisoning** Exhaust gases are toxic and inhaling them may result in unconsciousness and death.

- Always make sure there is sufficient ventilation when running the engine.
- Use effective exhaust extraction when starting or running the engine in an enclosed space.



### Warning

**Danger of burns** Some vehicle components become very hot when the vehicle is operated.

- Do not touch any parts such as the exhaust system, radiator, engine, shock absorber, or brake system before the vehicle parts have cooled down.
- Let the vehicle parts cool down before you perform any work on the vehicle.

Only operate the vehicle when it is in perfect technical condition, in accordance with its intended use, and in a safe and environmentally compatible manner.

The vehicle should only be used by trained persons.

Have malfunctions that impair safety promptly eliminated by an authorized KTM workshop.

Adhere to the information and warning labels on the vehicle.

## 2.7 Protective clothing



### Warning

**Risk of injury** Missing or poor protective clothing presents an increased safety risk.

- Ensure your child wears appropriate protective clothing such as helmet, boots, gloves as well as trousers and a jacket with protectors on all rides.
- Always use protective clothing for your child that is in good condition and meets the legal requirements.
- When you ride a motorcycle, set an example for your child and wear suitable protective clothing.

## 2 SAFETY ADVICE

In the interest of your own safety, KTM recommends that you only operate the vehicle while wearing suitable protective clothing.

### 2.8 Work rules

Unless specified otherwise, the ignition must be turned off during all work (models with ignition lock, models with remote key) or the engine must be at a standstill (models without ignition lock or remote key).

Special tools are necessary for certain tasks. The tools are not a component of the vehicle, but can be ordered using the number in parentheses. Example: bearing puller (15112017000)

Unless otherwise noted, normal conditions apply to all tasks and descriptions.

Ambient temperature	20 °C (68 °F)
Ambient air pressure	1,013 mbar (14.69 psi)
Relative air humidity	60 ± 5 %

During assembly, use new parts to replace parts which cannot be reused (e.g. self-locking screws and nuts, expansion screws, seals, sealing rings, O-rings, pins, and lock washers).

In the case of certain screws, a screw adhesive (e.g. **Loctite**®) is required. Observe the manufacturer's instructions.

If thread locker (e.g., **Precote**®) has already been applied to a new part, do not apply any additional thread locker. After disassembly, clean the parts that are to be reused and check them for damage and wear. Change damaged or worn parts.

After completing a repair or service work, check the operating safety of the vehicle.

### 2.9 Environment

If you use your motorcycle responsibly, you can ensure that problems and conflicts do not occur. To protect the future of the motorcycle sport, make sure that you use your motorcycle legally, display environmental consciousness, and respect the rights of others.

When disposing of used oil, other operating and auxiliary fluids, and used components, comply with the laws and regulations of the respective country.

Because motorcycles are not subject to the EU regulations governing the disposal of used vehicles, there are no legal regulations that pertain to the disposal of an end-of-life motorcycle. Your authorized KTM dealer will be glad to advise you.

### 2.10 Owner's Manual

It is important that you read this Owner's Manual carefully and completely before your child makes his or her first trip. The Owner's Manual contains useful information and many tips for you and your child on how to operate, handle, and service your motorcycle. This is the only way for you to find out how to ideally tune the vehicle and how to protect your child from injury.



#### Tip

Store the Owner's Manual on your terminal device, for example, so that you can read it whenever you need to.

If you would like to know more about the vehicle or have questions on the material you read, please contact an authorized KTM dealer.

The Owner's Manual is an important component of the vehicle. If the vehicle is sold, the Owner's Manual must be downloaded again by the new owner.

The Owner's Manual can be downloaded several times using the QR code or the link on the delivery certificate.

The Owner's Manual is also available for download from your authorized KTM dealer and on the KTM website. A printed copy can also be ordered from your authorized KTM dealer.

International KTM Website: [KTM.COM](http://KTM.COM)

**3.1 Manufacturer warranty, implied warranty**

The work prescribed in the service schedule must only be carried out in an authorized KTM workshop and confirmed in the **KTM Dealer.net**, as otherwise all warranty claims will be void. Damage or secondary damage caused by tampering with and/or conversions on the vehicle are not covered by the manufacturer warranty.

**3.2 Fuel, auxiliary substances**



**Note**

**Environmental hazard** Improper handling of fuel is a danger to the environment.

- Do not allow fuel to enter the groundwater, the soil, or the sewage system.

Use fuels and auxiliary substances in accordance with the Owner's Manual and specification.

**3.3 Spare parts, accessories**

For the safety of your child, only use spare parts and accessory products that are approved and/or recommended by KTM and have them installed by an authorized KTM workshop. KTM accepts no liability for other products and any resulting damage or loss.

Certain spare parts and accessory products are specified in parentheses in the descriptions. Your authorized KTM dealer will be glad to advise you.

The current **KTM PowerParts** for your vehicle can be found on the KTM website.

International KTM Website: [KTM.COM](http://KTM.COM)

**3.4 Service**

A prerequisite for perfect operation and prevention of premature wear is that the service, care, and tuning work on the engine and chassis is properly carried out as described in the Owner's Manual. An incorrect suspension setting can lead to damage and breakage of chassis components.

Use of the vehicle under difficult conditions, such as on sand or on wet, dusty and muddy surfaces, can result in significantly increased wear of components, such as the drive train, brake system, air filter or suspension components. For this reason, it may be necessary to inspect or replace parts before the next scheduled service.

It is imperative that you adhere to the stipulated run-in times and service intervals. If you observe these exactly, you will ensure a much longer service life for your motorcycle.

The relevant mileage or time interval is whichever occurs first.

**3.5 Figures**

The figures contained in the manual may depict special equipment.

In the interest of clarity, some components may be shown disassembled or may not be shown at all. It is not always necessary to disassemble the component to perform the activity in question. Please follow the instructions in the text.

**3.6 Customer service**

Your authorized KTM dealer will be happy to answer any questions you may have on your vehicle and KTM.

A list of authorized KTM dealers can be found on the KTM website.

International KTM Website: [KTM.COM](http://KTM.COM)

## 4 VIEW OF VEHICLE

### 4.1 View of vehicle, front left (example)



- ❶ Hand brake lever (📖 p. 14)
- ❷ Clutch lever (📖 p. 14)
- ❸ Fuel tank filler cap
- ❹ Air filter box cover
- ❺ Shift lever (📖 p. 16)
- ❻ Choke (📖 p. 16)
- ❼ Fuel tap (📖 p. 16)

## 4.2 View of vehicle, rear right (example)

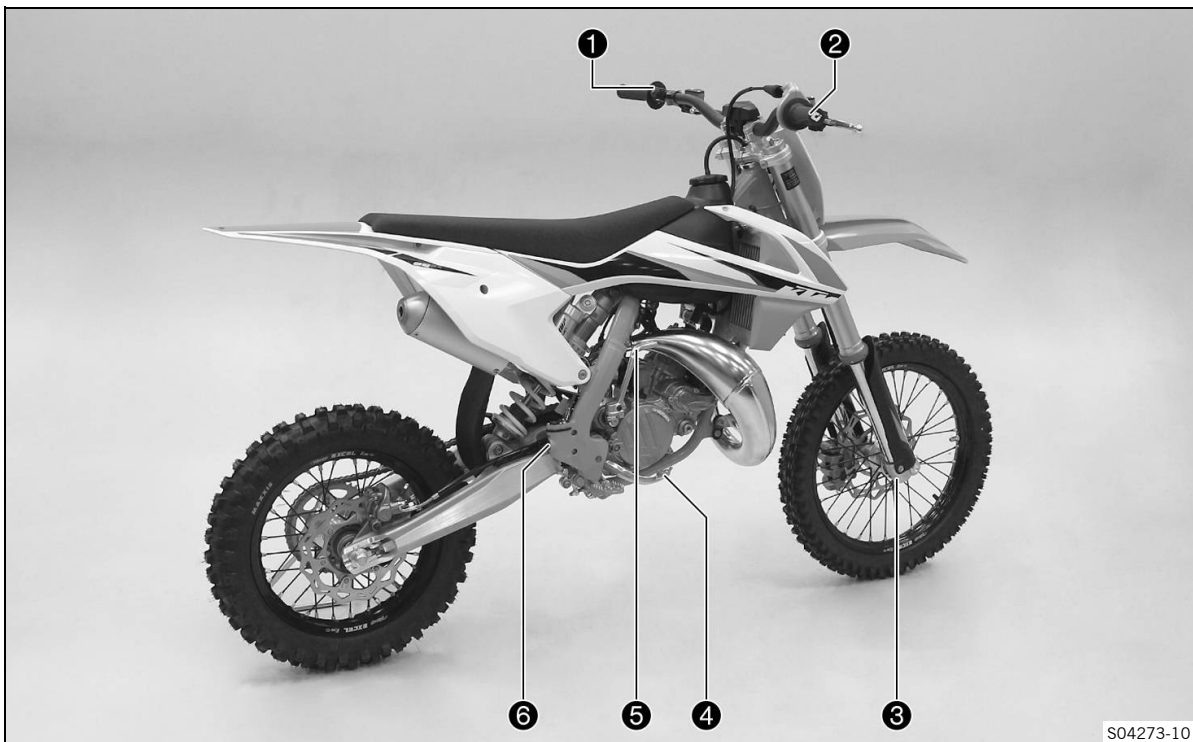

- ❶ Stop button (📖 p. 14)
- ❷ Throttle grip (📖 p. 14)
- ❸ Fork part number (📖 p. 12)
- ❹ Foot brake lever (📖 p. 17)
- ❺ Kick starter lever (📖 p. 17)
- ❻ Level viewer for brake fluid, rear

# 5 SERIAL NUMBERS

## 5.1 Vehicle identification number

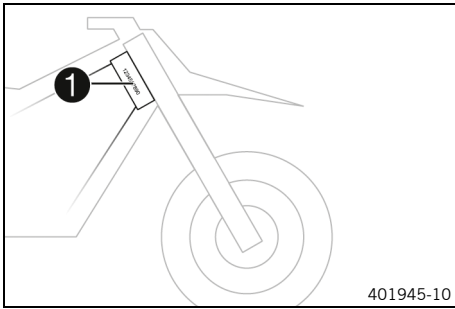

The vehicle identification number ❶ is stamped on the right side of the steering head.

## 5.2 Type label

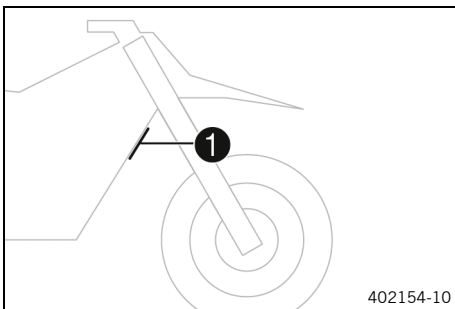

Type label ❶ is located on the front frame tube.

## 5.3 Engine number

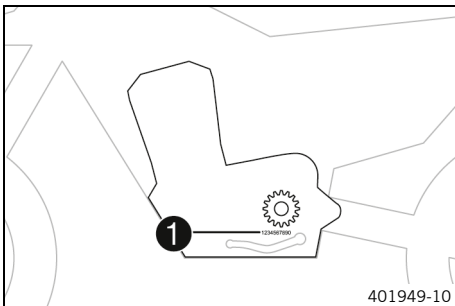

The engine number ❶ is located on the left side of the engine under the engine sprocket.

## 5.4 Fork part number

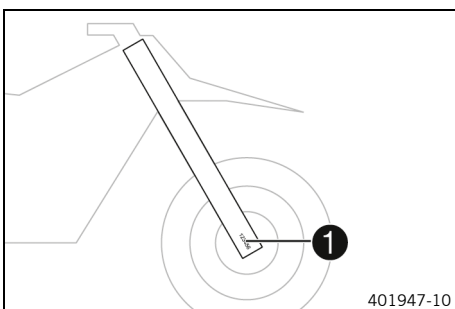

Fork part number ❶ is stamped on the inner side of the axle clamp.

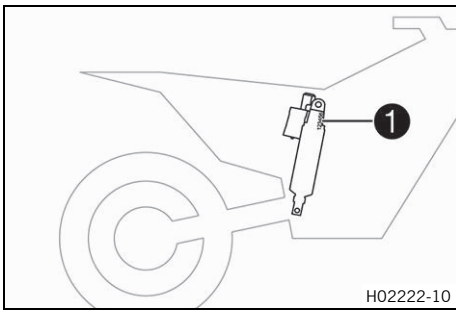
**5.5 Shock absorber article number**

The shock absorber part number **1** is stamped on the top of the shock absorber above the adjusting ring towards the engine side.

## 6.1 Clutch lever

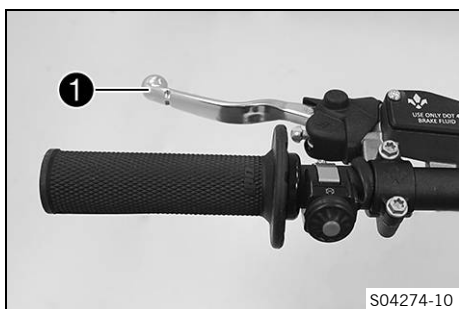

Clutch lever ❶ is fitted on the left side of the handlebar. The clutch is hydraulically operated and self-adjusting.

## 6.2 Hand brake lever

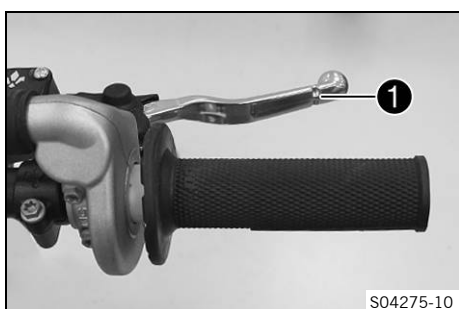

The hand brake lever ❶ is fitted on the right side of the handlebar.

The front brake is engaged using the hand brake lever.

## 6.3 Throttle grip

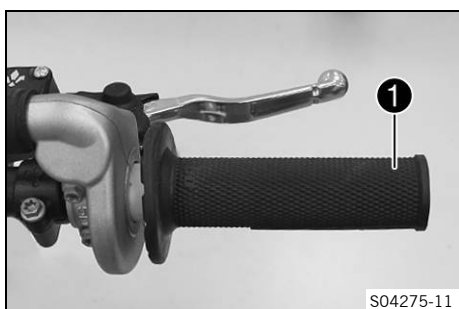

Throttle grip ❶ is fitted on the right side of the handlebar.

## 6.4 Stop button



The stop button ❶ is fitted on the left side of the handlebar.

### Possible states

- The stop button ☒ is in the basic position – In this position, the ignition circuit is closed and the engine can be started.
- Stop button ☒ pressed – In this position, the ignition circuit is interrupted, a running engine stops, and a non-running engine will not start.



## 6.5 Opening the fuel tank filler cap



### Danger

**Fire hazard** Fuel is highly flammable.

The fuel in the fuel tank expands when warm and can escape if overfilled.

- Do not fuel the vehicle in the vicinity of open flames or lit cigarettes.
- Switch off the engine for refueling.
- Make sure that no fuel is spilled; particularly not on hot parts of the vehicle.
- If any fuel is spilled, wipe it off immediately.
- Observe the specifications for refueling.



### Warning

**Danger of poisoning** Fuel is poisonous and a health hazard.

- Avoid skin, eye and clothing contact with fuel.
- Immediately consult a doctor if you swallow fuel.
- Do not inhale fuel vapors.
- In case of skin contact, rinse the affected area with plenty of water.
- Rinse the eyes thoroughly with water, and consult a doctor in case of fuel contact with the eyes.
- Change your clothing in case of fuel spills on them.
- Keep fuels correctly in a suitable canister, and out of the reach of children.



### Note

**Environmental hazard** Improper handling of fuel is a danger to the environment.

- Do not allow fuel to enter the groundwater, the soil, or the sewage system.

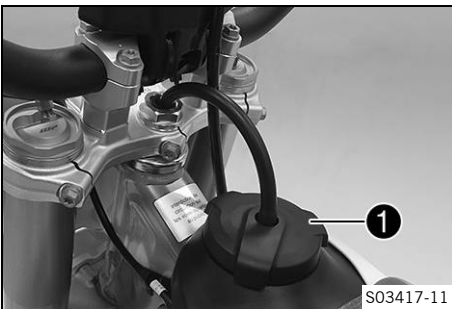

- Turn fuel tank filler cap ① counterclockwise and lift it off. ◀

## 6.6 Closing the fuel tank filler cap

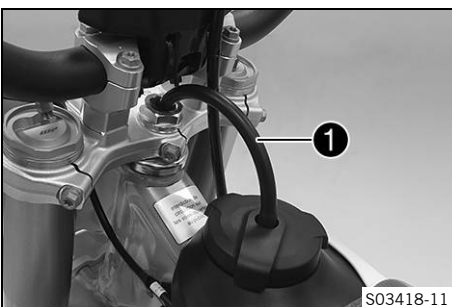

- Mount the fuel tank filler cap and turn it clockwise until the fuel tank is tightly closed.



### Info

Route fuel tank breather hose ① without kinks. ◀

## 6.7 Fuel tap

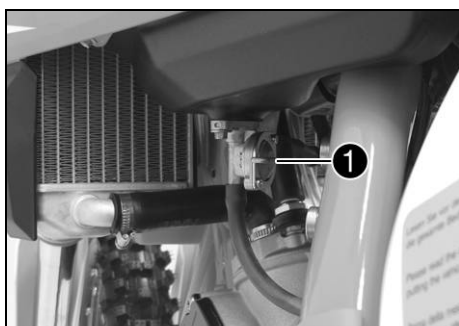

The fuel tap is on the left side of the fuel tank.

Using the tap handle **1** on the fuel tap, you can open or close the fuel supply to the carburetor.

### Possible states

- Fuel supply closed **OFF** – Fuel cannot flow from the fuel tank to the carburetor.
- Fuel supply open **ON** – Fuel can flow from the fuel tank to the carburetor. The fuel tank empties completely.

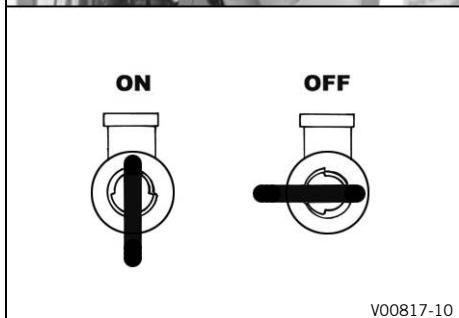

## 6.8 Choke

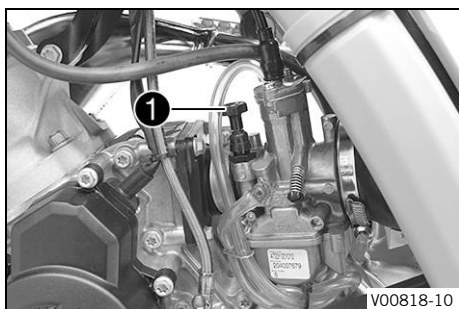

Choke **1** is fitted on the left side of the carburetor.

Activating the choke function frees a drill hole in the carburetor through which the engine can draw extra fuel. This results in a richer fuel-air mixture, which is needed for a cold start.

### **i** Info

If the engine is warm, the choke function must be deactivated.

### Possible states

- Choke function activated – The choke lever is pulled out to the stop.
- Choke function deactivated – The choke lever is pushed in to the stop.

## 6.9 Shift lever

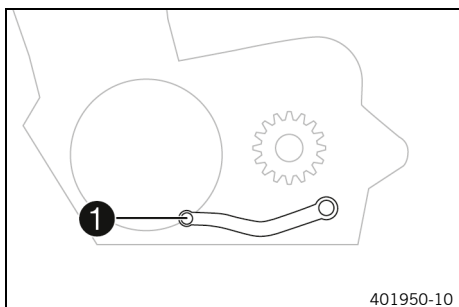

Shift lever **1** is mounted on the left side of the engine.

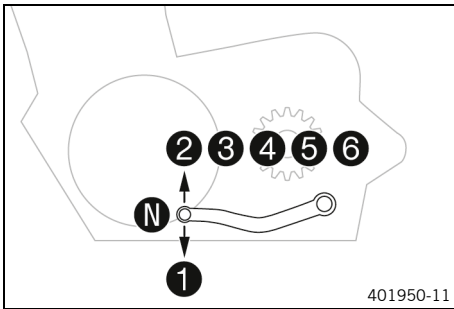

The gear positions can be seen in the photograph.  
The neutral or idle position **N** is between the first and second gears.

## 6.10 Kick starter lever

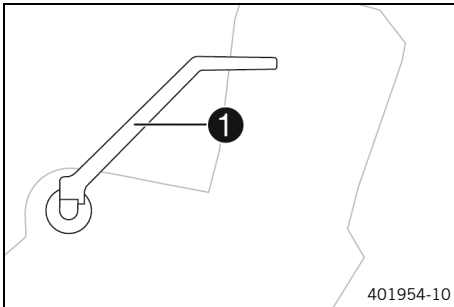

Kick starter lever **1** is fitted on the right side of the engine.  
The kick starter lever can be swiveled.

### **i** Info

Before riding, swing the kick starter lever inwards towards the engine.

## 6.11 Foot brake lever

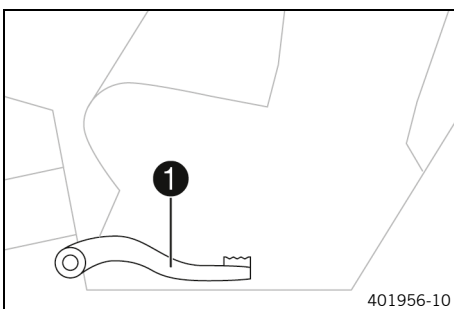

Foot brake lever **1** is located in front of the right footrest.  
The foot brake lever is used to activate the rear brake.

## 6.12 Plug-in stand

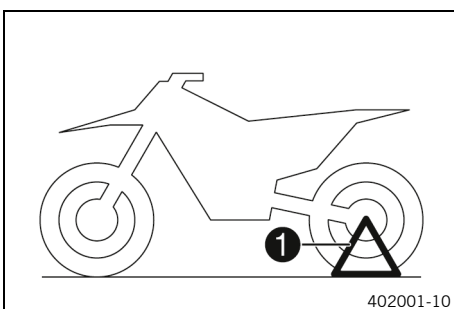

The support for plug-in stand **1** is the left side of the wheel spindle.

The plug-in stand is used to park the motorcycle.

### **i** Info

Remove the plug-in stand before riding.

## 6.13 Service hour counter



The service hour counter ① is attached below the seat. It shows the total number of service hours of the engine. The service hour counter begins counting when the engine is started and stops when the engine is switched off.

---

**i Info** The value indicated by the service hour counter cannot be cleared or adjusted.

---

7.1 Advice on preparing for first use

 **Warning**  
**Danger of accidents** A lack of physical and mental readiness on the part of the child poses a major risk. Children often underestimate or fail to recognize dangerous situations.

- Your child must already be able to ride a bicycle.
- Your child must be able to put the vehicle upright independently after a fall.
- Your child must understand that regulations and instructions from you or from other guardians must be followed.
- Make it clear to your child that he or she should not, under any circumstances, operate the vehicle without supervision.
- Make it clear to your child that he or she may only drive at speeds commensurate with the child's riding abilities and the road conditions.
- Do not ask too much of your child.

Do not consider participation in competitive activities until your child's stamina, riding techniques and motivation are at the necessary levels.

- Only let your child ride on the vehicle if he or she is physically and mentally ready.

 **Warning**  
**Risk of injury** Missing or poor protective clothing presents an increased safety risk.

- Ensure your child wears appropriate protective clothing such as helmet, boots, gloves as well as trousers and a jacket with protectors on all rides.
- Always use protective clothing for your child that is in good condition and meets the legal requirements.
- When you ride a motorcycle, set an example for your child and wear suitable protective clothing.

 **Warning**  
**Danger of crashing** Different tire tread patterns on the front and rear wheel impair the handling characteristic.

Different tire tread patterns can make the vehicle significantly more difficult to control.

- Make sure that only tires with a similar tire tread pattern are fitted to the front and rear wheel.

 **Warning**  
**Danger of accidents** An unadapted riding style constitutes a major risk.

- Ensure that your child adapts the riding speed to the road conditions and to his or her riding abilities.

 **Warning**  
**Danger of accidents** The vehicle is not designed to carry passengers.

- Make it clear to your child that he or she must not carry a passenger.

 **Warning**  
**Danger of accidents** The brake system fails in the event of overheating.

If the foot brake lever is not released, the brake linings drag continuously.

- Ensure that your child raises his or her foot from the foot brake lever if he or she does not want to brake.

 **Warning**  
**Danger of accidents** The suspension components will become damaged or destroyed if overloaded.

- Do not exceed the maximum permissible weight of the rider.



## Warning

**Risk of misappropriation** People who act without authorization endanger themselves and others.

- Do not leave the vehicle unattended if the engine is running.
- Protect the vehicle against access by unauthorized persons.



## Info

When using your motorcycle, remember that others may feel disturbed by excessive noise.

- Make sure that the pre-sales inspection work has been carried out by an authorized KTM workshop.
  - ✓ You will receive a delivery certificate when the vehicle is handed over.
- Carefully read the entire Owner's Manual together with your child before going for the first ride.



## Info

Pay particular attention to the safety instructions and risks of injury.

Explain to your child the techniques of riding and falling, e.g. how shifting weight can influence handling characteristics.

- Familiarize your child with the controls.
- Adjust the basic position of the clutch lever. (📖 p. 68)
- Adjust the free travel of the handbrake lever. (📖 p. 72)
- Adjust the basic position of the foot brake lever. 🦶 (📖 p. 78)
- Before using the vehicle for the first time, ensure that the basic settings of the chassis are suitable for the weight of your child.
- Allow your child to become accustomed to the handling of the motorcycle on suitable terrain, preferably on a large, open meadow.



## Info

To give your child a feeling for the brake system, start by pushing your child. Do not start the engine until your child is able to apply the necessary front brake pressure.

Initially, let your child ride to another person who can help your child stop and turn.

- Erect obstacles for your child to navigate around to accustom your child to handling the vehicle.
- Your child should also try to ride as slowly as possible and in a standing position to get a better feeling for the motorcycle.
- Do not let your child ride on terrain that exceed your child's capabilities and experience.
- Your child should hold the handlebar firmly with both hands and keep his or her feet on the footrests when riding.
- Make sure the maximum permissible weight of the rider is not exceeded.

Guideline

Maximum rider weight	75 kg (165 lb.)
----------------------	-----------------

- Check the spoke tension. (📖 p. 88)



## Info

The spoke tension must be checked after half an hour of operation.

- Run the engine in. (📖 p. 21)



## 7.2 Running in the engine

- During the running-in phase, do not exceed the specified engine performance.

Guideline

Maximum engine performance	
During the first 3 operating hours	< 70 %
During the first 5 operating hours	< 100 %

- Avoid fully opening the throttle!



## 7.3 Preparing the vehicle for difficult operating conditions

### **i** Info

Use of the vehicle under difficult conditions, such as on sand or on wet and muddy surfaces, can result in significantly increased wear of components, such as the drive train, brake system, or suspension components. For this reason, it may be necessary to inspect or replace parts before the next scheduled service.

- Clean the air filter and air filter box. 📖 (p. 57)

### **i** Info

Check the air filter approx. every 30 minutes.

- Check the electrical connector for humidity and corrosion and to ensure it is firmly seated.
  - » If humidity, corrosion, or damage is found:
    - Clean and dry the connector, or change it if necessary.

#### Difficult operating conditions are:

- Rides on dry sand. 📖 (p. 21)
- Rides on wet sand. 📖 (p. 23)
- Rides on wet and muddy circuits. 📖 (p. 23)
- Rides at high temperatures or slow riding. 📖 (p. 24)
- Riding at low temperatures and in snow. 📖 (p. 25)



## 7.4 Preparing the vehicle for riding on dry sand

- Make sure that no radiator covers 📖 (p. 90) are installed.
- Check the radiator cap.

Value on the radiator cap	1.8 bar (26 psi)
---------------------------	------------------

- » If the indicated value does not correspond to the setpoint value:



V00814-01



## Warning

**Danger of scalding** During motorcycle operation, the coolant gets very hot and is under pressure.

- Do not open the radiator, the radiator hoses or other cooling system components if the engine or the cooling system are at operating temperature.
- Allow the cooling system and the engine to cool down before you open the radiator, the radiator hoses or other components of the cooling system.
- In the event of scalding, rinse the area affected immediately with lukewarm water.



M01104-01



M01105-01

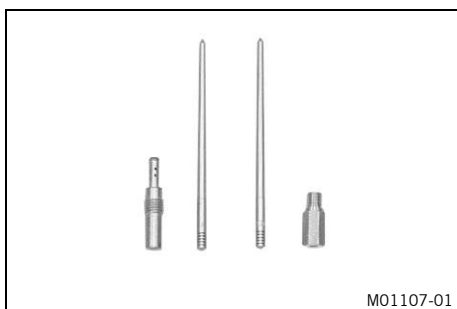

M01107-01

- Change the radiator cap.

- Mount the air filter dust cover.

Air filter dust cover (47206920000)



## Info

Observe the **KTM PowerParts** fitting instructions.

- Mount the air filter sand cover.

Air filter sand cover (79006922000)



## Info

Observe the **KTM PowerParts** fitting instructions.

- Adjust the carburetor jetting and setting.



## Info

Your authorized KTM workshop can recommend the right carburetor tuning.

- Clean the chain.

Chain cleaner (📖 p. 124)

- Grease the chain.

Universal oil spray (📖 p. 125)

- Clean the radiator fins.

- Straighten the bent radiator fins carefully.

## Condition

Regular use in sand

- Change the piston every 10 operating hours.



**7.5 Preparing the vehicle for riding on wet sand**

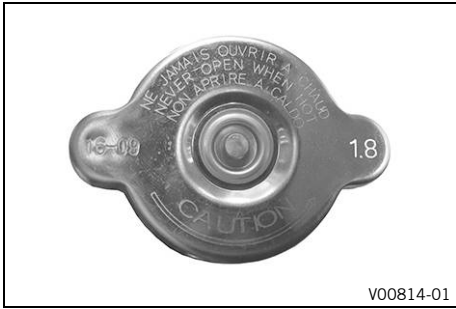

- Make sure that no radiator covers (📖 p. 90) are installed.
- Check the radiator cap.

Value on the radiator cap	1.8 bar (26 psi)
---------------------------	------------------

- » If the indicated value does not correspond to the setpoint value:



**Warning**

**Danger of scalding** During motorcycle operation, the coolant gets very hot and is under pressure.

- Do not open the radiator, the radiator hoses or other cooling system components if the engine or the cooling system are at operating temperature.
- Allow the cooling system and the engine to cool down before you open the radiator, the radiator hoses or other components of the cooling system.
- In the event of scalding, rinse the area affected immediately with lukewarm water.

- Change the radiator cap.

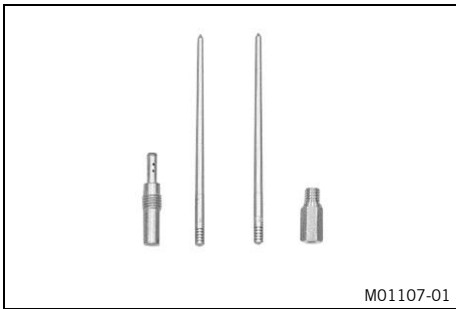

- Adjust the carburetor jetting and setting.



**Info**

Your authorized KTM workshop can recommend the right carburetor tuning.

- Clean the chain.

Chain cleaner (📖 p. 124)
--------------------------

- Grease the chain.

Universal oil spray (📖 p. 125)
--------------------------------

- Clean the radiator fins.
- Straighten the bent radiator fins carefully.

**Condition**

Regular use in sand

- Change the piston every 10 operating hours.



**7.6 Preparing vehicle for rides on wet and muddy circuits**

- Make sure that no radiator covers (📖 p. 90) are installed.

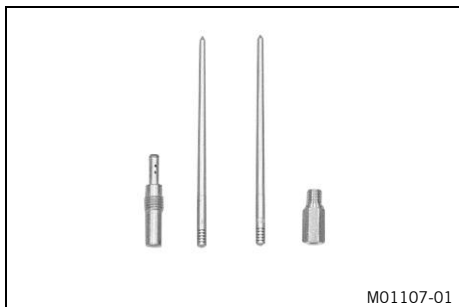

M01107-01

- Adjust the carburetor jetting and setting.



### Info

Your authorized KTM workshop can recommend the right carburetor tuning.

- Clean the motorcycle. (📖 p. 108)
- Straighten bent radiator fins carefully.

## 7.7 Preparing vehicle for high temperatures or slow riding



V00814-01

- Make sure that no radiator covers (📖 p. 90) are installed.
- Check the radiator cap.

Value on the radiator cap	1.8 bar (26 psi)
---------------------------	------------------

- » If the indicated value does not correspond to the setpoint value:



### Warning

**Danger of scalding** During motorcycle operation, the coolant gets very hot and is under pressure.

- Do not open the radiator, the radiator hoses or other cooling system components if the engine or the cooling system are at operating temperature.
- Allow the cooling system and the engine to cool down before you open the radiator, the radiator hoses or other components of the cooling system.
- In the event of scalding, rinse the area affected immediately with lukewarm water.

- Change the radiator cap.
- Adjust the secondary drive to the road conditions.



### Info

The engine oil heats up quickly when the clutch is operated frequently due to an excessively high secondary ratio.

- Clean the radiator fins.
- Straighten the bent radiator fins carefully.
- Check the coolant level. (📖 p. 93)

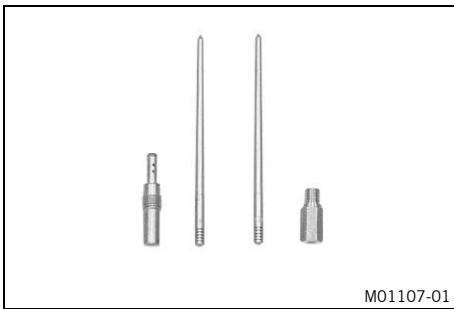

600868-01

**7.8 Preparing the vehicle for low temperatures or snow**

- Adjust the carburetor jetting and setting.

**Info**

Your authorized KTM workshop can recommend the right carburetor tuning.

## 8.1 Checks and maintenance measures when preparing for use

### **i** Info

Before every trip, check the condition of the vehicle and ensure that it is safe to operate. The vehicle must be in perfect technical condition when it is being operated.

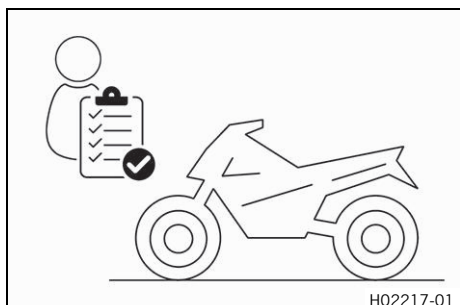

- Check the gear oil level. (📖 p. 105)
- Check the front brake fluid level. (📖 p. 73)
- Check the rear brake fluid level. (📖 p. 79)
- Check the front brake linings. (📖 p. 75)
- Check the rear brake linings. (📖 p. 80)
- Check that the brake system is functioning properly.
- Check the coolant level. (📖 p. 93)
- Check for chain dirt accumulation. (📖 p. 62)
- Check the chain, rear sprocket, engine sprocket, and chain guide. (📖 p. 65)
- Check the chain tension. (📖 p. 63)
- Check the tire condition. (📖 p. 87)
- Check tire pressure. (📖 p. 88)
- Check the spoke tension. (📖 p. 88)

### **i** Info

The spoke tension must be checked regularly as incorrect spoke tension will strongly impair riding safety.

- Clean the dust boots of the fork legs. (📖 p. 45)
- Bleed the fork legs. (📖 p. 44)
- Check the air filter.
- Check the settings of all controls and ensure that they can be operated smoothly.
- Check all screws, nuts, and hose clamps regularly for tightness.
- Check the fuel level.

## 8.2 Starting the vehicle



### **Danger**

**Danger of poisoning** Exhaust gases are toxic and inhaling them may result in unconsciousness and death.

- Always make sure there is sufficient ventilation when running the engine.
- Use effective exhaust extraction when starting or running the engine in an enclosed space.

### **Note**

**Engine failure** High rpm with a cold engine negatively impacts the lifespan of the engine.

- Ensure that the engine is always warmed up at low engine speeds.

### **i** Info

If the motorcycle is unwilling to start, the cause can be old fuel in the float chamber. The flammable elements of the fuel evaporate after a long time of standing.

If the float chamber is filled with fresh fuel, the engine starts immediately.

**The motorcycle has been out of use for more than 1 week**

- Empty the carburetor float chamber.  (p. 102)
- Turn tap handle of the fuel tap to the **ON** position.
  - ✓ Fuel can flow from the fuel tank to the carburetor.
- Remove the motorcycle from the stand.
- Shift the transmission into neutral.

**The engine is cold**

- Pull the choke lever out as far as possible.
- Press the kick starter lever robustly through its full range.



**Info**

Do not open the throttle.



## 8.3 Starting off



**Info**

The plug-in stand must be removed before riding.

- Pull the clutch lever, engage 1st gear, release the clutch lever slowly and simultaneously open the throttle carefully.



## 8.4 Shift, ride



**Warning**

**Danger of accidents** If you change down at high engine speed, the rear wheel blocks and the engine races.

- Make it clear to your child that he or she must not change into a low gear at high engine speed.



**Info**

If unusual noises occur while riding, stop immediately, switch off the engine and contact an authorized KTM workshop.

First-gear is used for starting off and for steep inclines.

- When conditions allow (incline, road situation, etc.), your child can shift into a higher gear. To do so, release the throttle while simultaneously pulling the clutch lever, shift into the next gear, release the clutch lever and open the throttle.
- If the choke function has been activated, deactivate it after the engine has warmed up.
- After reaching maximum speed by fully opening the throttle grip, turn the throttle back so it is  $\frac{3}{4}$  open. This will barely reduce the speed, but fuel consumption will be considerably lower.
- Your child should always open the throttle only as much as the engine can handle – abruptly opening the throttle increases fuel consumption.
- To shift down, apply the brakes and close the throttle at the same time.
- Pull the clutch lever and shift into a lower gear, release the clutch lever slowly, and either open the throttle or shift again.
- Your child should switch off the engine if prolonged operation at idle speed or while stationary is imminent.

Guideline

≥ 2 min

- Your child should avoid frequent and extended slipping of the clutch. This causes the engine oil, engine and cooling system to heat up.
- Insist that your child ride with a low speed instead of with a high speed and a slipping clutch.

### 8.5 Braking



#### Warning

**Danger of accidents** Excessively forceful application of the brakes blocks the wheels.

- Explain to your child that he or she must adapt the braking to the traffic situation and the road conditions.



#### Warning

**Danger of accidents** A spongy pressure point on the front or rear brake reduces braking efficiency.

- Check the brake system and do not allow your child to continue riding until the problem is eliminated. (Your authorized KTM workshop will be glad to help.)



#### Warning

**Danger of accidents** Moisture and dirt impair the brake system.

- Explain to your child that he or she must brake carefully several times to dry out and remove dirt from the brake linings and the brake discs.

- On sandy, wet, or slippery surfaces, use the rear brake.
- Always finish braking before the going into a bend. Your child should change down to a lower gear appropriate to the road speed.
- Insist that your child take advantage of the braking action of the engine when riding on long downhill. To do so, shift back one or two gears, but do not overrev the engine. Your child will need to apply the brakes far less often and the brake system will not overheat.

### 8.6 Stopping, parking



#### Warning

**Risk of misappropriation** People who act without authorization endanger themselves and others.

- Do not leave the vehicle unattended if the engine is running.
- Protect the vehicle against access by unauthorized persons.



#### Warning

**Danger of burns** Some vehicle components become very hot when the vehicle is operated.

- Do not touch any parts such as the exhaust system, radiator, engine, shock absorber, or brake system before the vehicle parts have cooled down.
- Let the vehicle parts cool down before you perform any work on the vehicle.

#### Note

**Material damage** The vehicle may be damaged by incorrect procedure when parking.

Significant damage may be caused if the vehicle rolls away or falls over.

The components for parking the vehicle are designed only for the weight of the vehicle.

- Park the vehicle on a firm and level surface.
- Ensure that nobody sits on the vehicle when the vehicle is parked on a stand.

**Note**

**Fire hazard** Hot vehicle components pose a fire hazard and explosion risk.

- Do not park the vehicle near to materials which are highly flammable or explosive.
- Allow the vehicle to cool down before covering it.

- Apply the brakes on the motorcycle.
- Shift the transmission into neutral.
- Press and hold the stop button  while the engine is idling until the engine stops.
- Turn tap handle of the fuel tap to the **OFF** position.
- Park the motorcycle on firm ground.



## 8.7 Transporting

**Note**

**Danger of damage** The parked vehicle can roll away or fall over.

- Park the vehicle on a firm and level surface.

**Note**

**Fire hazard** Hot vehicle components pose a fire hazard and explosion risk.

- Do not park the vehicle near to materials which are highly flammable or explosive.
- Allow the vehicle to cool down before covering it.

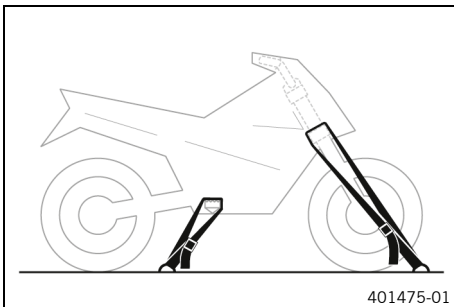

- Switch off the engine.
- Use tension belts or other suitable devices to secure the motorcycle against falling over or rolling away.

## 8.8 Refueling



**Danger**

**Fire hazard** Fuel is highly flammable.

The fuel in the fuel tank expands when warm and can escape if overfilled.

- Do not fuel the vehicle in the vicinity of open flames or lit cigarettes.
- Switch off the engine for refueling.
- Make sure that no fuel is spilled; particularly not on hot parts of the vehicle.
- If any fuel is spilled, wipe it off immediately.
- Observe the specifications for refueling.



## Warning

**Danger of poisoning** Fuel is poisonous and a health hazard.

- Avoid skin, eye and clothing contact with fuel.
- Immediately consult a doctor if you swallow fuel.
- Do not inhale fuel vapors.
- In case of skin contact, rinse the affected area with plenty of water.
- Rinse the eyes thoroughly with water, and consult a doctor in case of fuel contact with the eyes.
- Change your clothing in case of fuel spills on them.



## Note

**Environmental hazard** Improper handling of fuel is a danger to the environment.

- Do not allow fuel to enter the groundwater, the soil, or the sewage system.

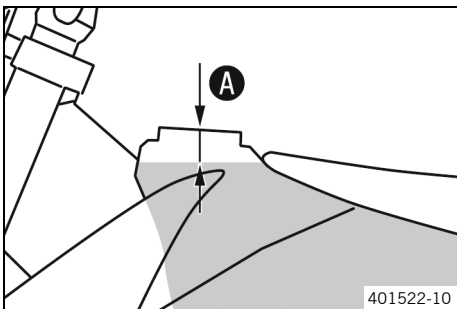

- Switch off the engine.
- Open the fuel tank filler cap. (📖 p. 15)
- Fill the fuel tank with fuel up to measurement **A**.

Guideline

Measurement of <b>A</b>	35 mm (1.38 in)	
Fuel tank capacity, approx.	5.2 l (1.37 US gal)	Super unleaded (98 octane) mixed with 2-stroke engine oil (1:40) (📖 p. 123)
Engine oil, 2-stroke (📖 p. 122)		

- Close the fuel tank filler cap. (📖 p. 15)



## 9.1 Additional information

Any further work that results from the compulsory work or from the recommended work must be ordered separately and invoiced separately.

Different service intervals may apply in your country, depending on the local operating conditions.

Individual service intervals and scopes may change in the course of technical developments. The most up-to-date service schedule can always be found on KTM Dealer.net. Your authorized KTM dealer will be happy to advise you.

## 9.2 Required work

	after every race			
	Every 40 operating hours			
	Every 20 operating hours			
	After 10 operating hours / Every 10 operating hours			
Check the front brake linings. (📖 p. 75)	○	●	●	●
Check the rear brake linings. (📖 p. 80)	○	●	●	●
Check the brake discs. (📖 p. 72)	○	●	●	
Check the brake lines for damage and leakage.	○	●	●	●
Change the foot brake cylinder sealing cup. 🛠️		●	●	●
Check the rear brake fluid level. (📖 p. 79)	○	●	●	●
Check the free travel of the foot brake lever. (📖 p. 78)	○	●	●	●
Check the frame. 🛠️ (📖 p. 67)		●	●	●
Check the link fork. 🛠️ (📖 p. 67)		●	●	●
Check the fork bearing for play. 🛠️		●	●	
Check the shock absorber heim joint for play. 🛠️		●	●	
Check the tire condition. (📖 p. 87)	○	●	●	●
Check tire pressure. (📖 p. 88)	○	●	●	●
Check the wheel bearing for play. 🛠️		●	●	●
Check the wheel hubs. 🛠️		●	●	●
Check the rim run-out. 🛠️	○	●	●	
Check the spoke tension. (📖 p. 88)	○	●	●	●
Check the chain, rear sprocket, engine sprocket, and chain guide. (📖 p. 65)	○	●	●	●
Check the chain tension. (📖 p. 63)	○	●	●	●
Grease all moving parts (e.g., hand lever, chain, ...) and check for smooth operation. 🛠️	○	●	●	●
Check the fluid level of the hydraulic clutch. (📖 p. 69)	○	●	●	●
Check the front brake fluid level. (📖 p. 73)	○	●	●	●
Check the free travel of the hand brake lever. (📖 p. 72)	○	●	●	●
Check the steering head bearing play. (📖 p. 51)	○	●	●	
Change the spark plug and spark plug connector. 🛠️		●	●	●
Change the gear oil. 🛠️ (📖 p. 105)	○	●	●	
Check all hoses (e.g. fuel, cooling, bleeder, drainage, etc.) and sleeves for cracking, leaks, and incorrect routing. 🛠️	○	●	●	●
Check the antifreeze and coolant level. (📖 p. 92)	○	●	●	●
Check the cables for damage and for routing without kinks. 🛠️	○	●	●	●
Check that the throttle cables are undamaged, routed without sharp bends, and set correctly.		●	●	●
Clean the air filter and air filter box. 🛠️ (📖 p. 57)	○	●	●	●
Change the glass fiber yarn filling of the main silencer. 🛠️ (📖 p. 58)			●	

# 9 SERVICE SCHEDULE

	after every race			
	Every 40 operating hours			
	Every 20 operating hours			
	After 10 operating hours / Every 10 operating hours			
Service the fork. 🛠️			•	
Perform the shock absorber service. 🛠️			•	
Check the tightness of the easily accessible, safety-relevant screws and nuts. 🛠️	○	•	•	•
Check the idle speed. 🛠️	○	•	•	•
Final check: Check the vehicle for operating safety and take a test ride. 🛠️	○	•	•	•
Make a service entry in <b>KTM Dealer.net</b> . 🛠️	○	•	•	•

- One-time interval
- Periodic interval

## 9.3 Recommended work

	every 48 months			
	every 12 months			
	after every race			
	Every 40 operating hours			
	After 20 operating hours / Every 20 operating hours			
	After 10 operating hours / Every 10 operating hours			
Change the front brake fluid. 🛠️			•	•
Change the rear brake fluid. 🛠️		•	•	•
Change the hydraulic clutch fluid. 🛠️ (📖 p. 70)			•	•
Lubricate the steering head bearing. 🛠️ (📖 p. 53)			•	•
Service the fork. 🛠️	○			
Perform the shock absorber service. 🛠️		○		
Check/set the carburetor components. 🛠️			•	•
Change the coolant. 🛠️ (📖 p. 95)				•
Perform minor engine service. (Check the inlet membrane. Check the clutch. Under difficult operating conditions: Change the piston and check the cylinder and Z dimension.) 🛠️	•	•	•	•
Perform the intermediate engine service. (Change the piston. Check the cylinder and Z dimension. Check the exhaust control for functioning and smooth operation.) 🛠️		•	•	
Perform major engine service including removing and installing engine. (Change the connecting rod, conrod bearing, and crank pin. Check the transmission and shift mechanism. Change all engine bearings.) 🛠️			•	

- One-time interval
- Periodic interval

## 10.1 Checking the basic chassis setting with rider's weight

### **i** Info

When adjusting the basic chassis setting, first adjust the shock absorber and then the fork.

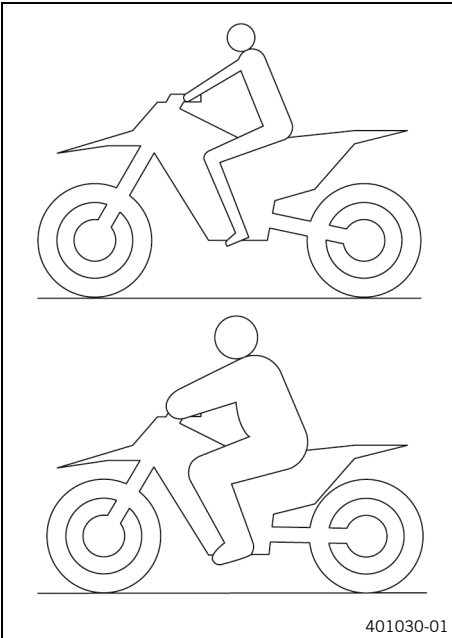

401030-01

- For optimal motorcycle riding characteristics and to avoid damage to forks, shock absorbers, link fork and frame, the basic settings of the suspension components must match the rider's weight.
- This vehicle is delivered pre-set for a standard rider's weight (with full protective clothing).

#### Guideline

Standard rider weight	45 ... 55 kg (99 ... 121 lb.)
-----------------------	-------------------------------

- If the rider's weight is above or below this range, the basic setting of the suspension components must be adjusted accordingly.
- Small weight differences can be compensated by adjusting the spring preload, but in the case of large weight differences, the springs must be replaced.



## 10.2 Air suspension XACT 5543

Air suspension **WP Suspension XACT 5543** is used in the fork.

In this system, suspension is located in the left fork leg and damping in the right fork leg.

As fork springs are no longer required, a significant weight advantage is achieved when compared to conventional forks. The response on slightly uneven surfaces is significantly improved.

In normal driving mode, suspension is provided exclusively by an air cushion. A steel spring is located in the left fork leg as an end stop.

### **i** Info

If the fork is frequently overloaded, then the air pressure in the fork must be increased to avoid damage to the fork and frame.

The air pressure in the fork can be quickly adjusted to the rider's weight, surface conditions and the rider's preference using a fork airpump. The fork does not have to be dismantled. The time consuming mounting of harder or softer fork springs is not required.

If the air chamber loses air due to a damaged seal, the fork will still not sag. In this case the air is retained in the fork. The suspension travel is maintained as far as possible. The damping becomes harder and the riding comfort reduces.

As with a conventional fork, the damping can be adjusted in rebound and compression stages.

The rebound adjustment is located at the upper end of the right fork leg.

The compression adjuster is located at the lower end of the right fork leg.

## 10.3 Compression damping of the shock absorber

The compression damping of the shock absorber is divided into two ranges: high-speed and low-speed.

High-speed and low-speed refer to the compression speed of the rear wheel suspension and not to the vehicle speed.

The high-speed compression adjuster has an effect, for example, when landing after a jump: the rear wheel suspension compresses quickly.

The low-speed compression adjuster has an effect, for example, when riding over long ground swells: the rear wheel suspension compresses slowly.

These two ranges can be adjusted separately, although the transition between high-speed and low-speed is gradual. Thus, modifications in the high-speed range affect the compression damping in the low-speed range and vice versa.

## 10.4 Adjusting the low-speed compression damping of the shock absorber



### Caution

**Risk of injury** Parts of the shock absorber will move around if the shock absorber is detached incorrectly.

The shock absorber is filled with highly compressed nitrogen.

- Please follow the description provided. (Your authorized KTM workshop will be glad to help.)



### Info

The effect of the low-speed compression adjuster can be seen in slow to normal compression of the shock absorber.

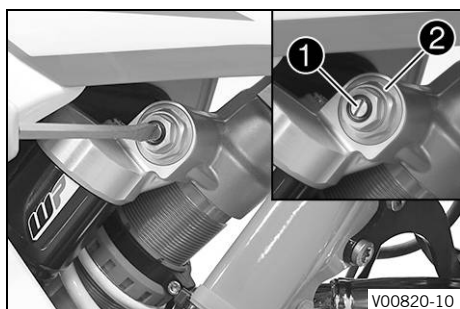

- Turn adjusting screw **1** clockwise with a screwdriver as far as the last perceptible click.



### Info

Do not loosen fitting **2**!

- Turn counterclockwise by the number of clicks corresponding to the shock absorber type.

Guideline

Low-speed compression damping	
Comfort	18 clicks
Standard	15 clicks
Sport	12 clicks



### Info

Turn clockwise to increase damping; turn counterclockwise to reduce damping.

**10.5 Adjusting the high-speed compression damping of the shock absorber**

**Caution**  
**Risk of injury** Parts of the shock absorber will move around if the shock absorber is detached incorrectly. The shock absorber is filled with highly compressed nitrogen.  
 – Please follow the description provided. (Your authorized KTM workshop will be glad to help.)

**Info**  
 The effect of the high-speed compression adjuster can be seen in fast compression of the shock absorber.

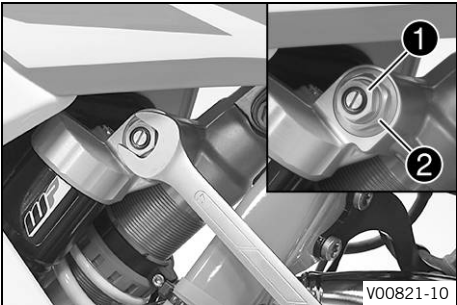

- Turn adjusting screw ❶ clockwise all the way.

**Info**  
 Do not loosen fitting ❷!

- Turn counterclockwise by the number of turns corresponding to the shock absorber type.

Guideline

High-speed compression damping	
Comfort	2.5 turns
Standard	2 turns
Sport	1.5 turns

**Info**  
 Turn clockwise to increase damping; turn counterclockwise to reduce damping.

**10.6 Adjusting the rebound damping of the shock absorber**

**Caution**  
**Risk of injury** Parts of the shock absorber will move around if the shock absorber is detached incorrectly. The shock absorber is filled with highly compressed nitrogen.  
 – Please follow the description provided. (Your authorized KTM workshop will be glad to help.)

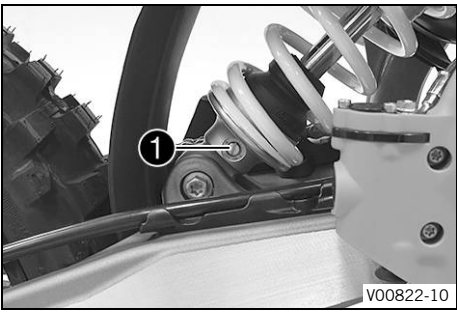

- Turn adjusting screw ❶ clockwise up to the last perceptible click.
- Turn counterclockwise by the number of clicks corresponding to the shock absorber type.

Guideline

Rebound damping	
Comfort	18 clicks
Standard	15 clicks
Sport	12 clicks

**i Info**

Turn clockwise to increase the damping; turn counter-clockwise to reduce damping when the shock absorber rebounds.

## 10.7 Measuring the dimension of the rear wheel unloaded

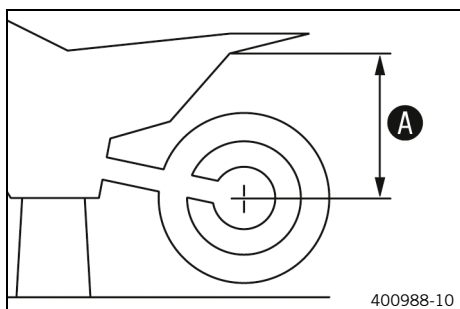

**Preparatory work**

- Raise the motorcycle with a lift stand. (📖 p. 44)

**Main work**

- Measure the vertical distance between the rear axle and a fixed point, such as a marking on the side cover.
- Note the value as dimension **A**.

**Finishing work**

- Remove the motorcycle from the lift stand. (📖 p. 44)

## 10.8 Checking the static sag of the shock absorber

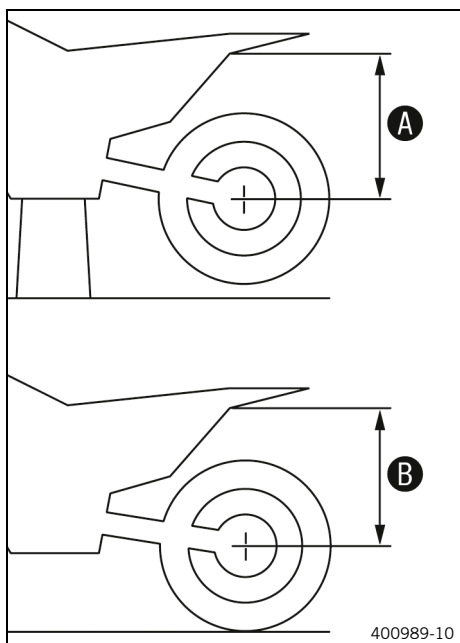

- Measure dimension **A** of rear wheel unloaded. (📖 p. 36)
- Hold the motorcycle upright with aid of an assistant.
- Measure the distance between rear axle and fixed point again.
- Note the value as dimension **B**.

**i Info**

The static sag is the difference between measurements **A** and **B**.

- Check the static sag.

Static sag	30 mm (1.18 in)
------------	-----------------

- » If the static sag is less or more than the specified value:
  - Adjust the spring preload of the shock absorber. (📖 p. 37)

## 10.9 Checking the riding sag of the shock absorber

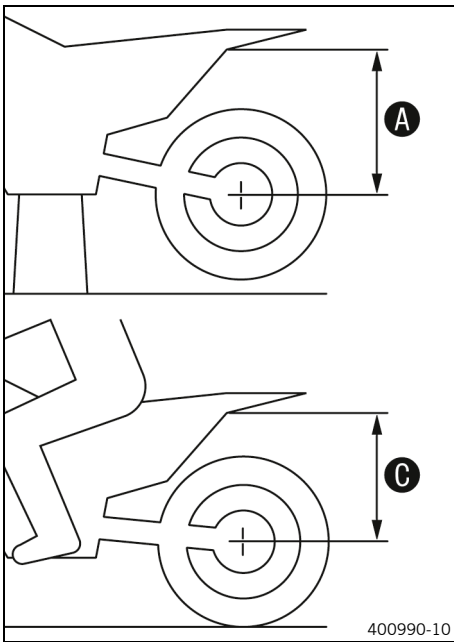

- Measure dimension **A** of rear wheel unloaded. (📖 p. 36)
- With another person holding the motorcycle, the rider, wearing full protective clothing, sits on the seat in a normal sitting position (feet on footrests) and bounces up and down a few times.
  - ✓ The rear wheel suspension levels out.
- Another person now measures the distance between the rear axle and the fixed point.
- Note the value as dimension **C**.

**i Info**  
The riding sag is the difference between measurements **A** and **C**.

- Check riding sag.

Riding sag	120 mm (4.72 in)
------------	------------------

- » If the riding sag differs from the specified measurement:
  - Adjust the riding sag. 🛠️ (📖 p. 38)

## 10.10 Adjusting the spring preload of the shock absorber 🛠️



### Caution

**Risk of injury** Parts of the shock absorber will move around if the shock absorber is detached incorrectly.

The shock absorber is filled with highly compressed nitrogen.

- Please follow the description provided. (Your authorized KTM workshop will be glad to help.)

### Preparatory work

- Raise the motorcycle with a lift stand. (📖 p. 44)
- Remove the shock absorber. 🛠️ (📖 p. 54)
- After removing the shock absorber, clean it thoroughly.

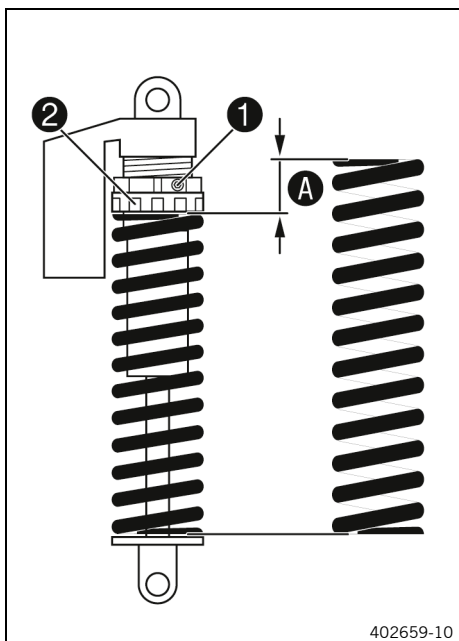

## Main work

- Measure the full spring length while it is under tension and note down the value.
- Loosen screw ①.
- Turn adjusting ring ② until the spring is no longer under tension.

Hook wrench (90129051000)

## i Info

If the spring cannot be fully released, the spring must be removed to accurately measure the spring length.

- Measure the total spring length while the spring is not under tension.
- Tension the spring by turning adjusting ring ② to specified dimension A.

## Guideline

Spring preload	11 mm (0.43 in)
----------------	-----------------

## i Info

The spring preload is the difference between the relaxed spring length and the tensioned spring length. Depending on the static sag and/or the riding sag, it may be necessary to increase or decrease the spring preload.

- Tighten screw ①.

## Guideline

Screw, shock absorber adjusting ring	M5	5 Nm (3.7 lbf ft)
--------------------------------------	----	-------------------

## Finishing work

- Install the shock absorber. 🛠️ (📖 p. 55)
- Remove the motorcycle from the lift stand. (📖 p. 44)

## 10.11 Adjusting the riding sag 🛠️

### Preparatory work

- Raise the motorcycle with a lift stand. (📖 p. 44)
- Remove the shock absorber. 🛠️ (📖 p. 54)
- After removing the shock absorber, clean it thoroughly.

### Main work

- Choose and mount a suitable spring.

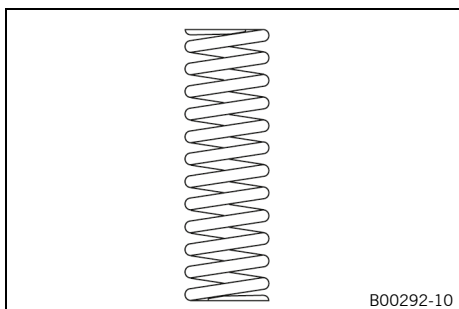



## Guideline

Spring rate	
Weight of rider: < 45 kg (< 99 lb.)	35 N/mm (200 lb/in)
Weight of rider: 45 ... 55 kg (99 ... 121 lb.)	40 N/mm (228 lb/in)
Weight of rider: > 55 kg (> 121 lb.)	45 N/mm (257 lb/in)

**i Info**  
The spring rate is shown on the outside of the spring. Smaller weight differences can be compensated by changing the spring preload.

### Finishing work

- Install the shock absorber. (🔧 p. 55)
- Remove the motorcycle from the lift stand. (🔧 p. 44)
- Check the static sag of the shock absorber. (🔧 p. 36)
- Check the riding sag of the shock absorber. (🔧 p. 37)
- Adjust the rebound damping of the shock absorber. (🔧 p. 35)

## 10.12 Checking the basic setting of the fork

**i Info**  
For various reasons, no exact riding sag can be determined for the fork.

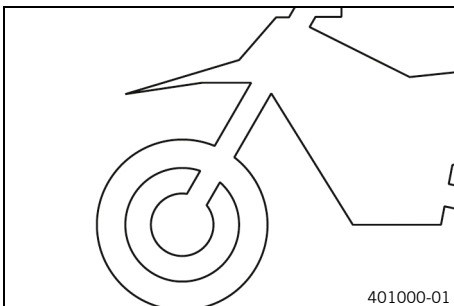

- Smaller differences in the rider's weight can be compensated for by the fork air pressure.
- However, if the fork frequently bottoms out (hard end stop on compression), the fork air pressure must be increased, within the specified values, to avoid damage to the fork and frame.

## 10.13 Adjusting the fork air pressure

**⚠ Warning**  
**Danger of accidents** Modifications to the suspension setting may seriously alter the handling characteristic.

Extreme modifications to the suspension setting may cause a serious deterioration in the handling characteristic and overload components.

- Only make adjustments within the recommended range.
- Make sure your child rides slowly to start with after making adjustments in order that he or she can assess the new handling characteristic.

**i Info**

Check or adjust the air pressure under the same conditions at the earliest 5 minutes after switching off the engine.

The air suspension is located in the left fork leg. The rebound damping is located in the right fork leg.

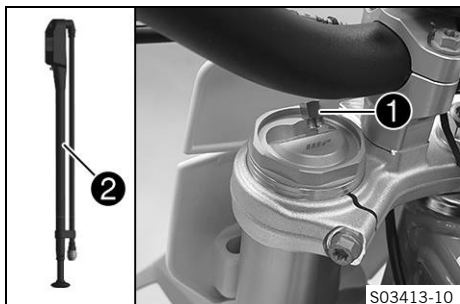

S03413-10

**Preparatory work**

- Raise the motorcycle with a lift stand. (🛠️ p. 44)

**Main work**

- Remove protection cap ①.
- Push together fork airpump ② fully.

Fork airpump (79412966100)

**i Info**

The fork airpump is included as part of the motorcycle's accessory pack.

- Connect the fork airpump to the left fork leg.
  - ✓ The fork airpump switches on automatically.
  - ✓ A little air escapes from the fork leg when connecting.

**i Info**

This is due to the volume of the hose and not due to a defect in the fork airpump or the fork.  
Read the accompanying **KTM PowerParts** instructions.

- Adjust the air pressure as specified.

Guideline

Air pressure	5 bar (73 psi)
Gradual changing of the air pressure in steps of	0.2 bar (3 psi)
Minimum air pressure	4 bar (58 psi)
Maximum air pressure	8 bar (116 psi)

**i Info**

Never adjust the air pressure to a value outside the stated range.

- Disconnect the fork airpump from the left fork leg.
  - ✓ When disconnecting, excess pressure will escape from the hose – the fork leg does not lose any air.
  - ✓ The fork pump airpump switches off automatically after 80 seconds.
- Mount the protection cap.

**i Info**

Only mount the protection cap by hand.

**Finishing work**

- Remove the motorcycle from the lift stand. (🛠️ p. 44)

## 10.14 Adjusting the compression damping of the fork

**i Info**

The hydraulic compression damping determines the fork suspension behavior.

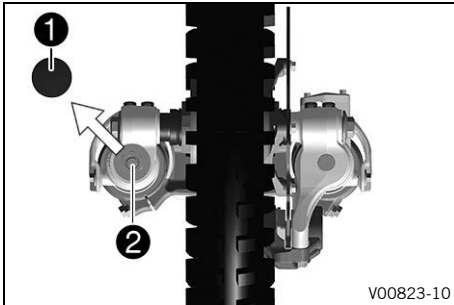

- Take off protection cap ①.
- Turn adjusting screw ② clockwise all the way.

**i Info**

The adjusting screw ② is located at the lower end of the right fork leg.

- Turn counterclockwise by the number of clicks corresponding to the fork type.

Guideline

Compression damping	
Comfort	17 clicks
Standard	12 clicks
Sport	7 clicks

**i Info**

Turn clockwise to increase damping; turn counterclockwise to reduce damping during compression.

- Mount protection cap ①.



## 10.15 Adjusting the rebound damping of the fork

**i Info**

The hydraulic rebound damping determines the fork suspension behavior.



- Turn red adjusting screw ① clockwise as far as it will go.

**i Info**

Adjusting screw ① is located at the upper end of the right fork leg. The rebound damping is located in right fork leg **REB** (red adjusting screw).

- Turn counterclockwise by the number of clicks corresponding to the fork type.

Guideline

Rebound damping	
Comfort	17 clicks
Standard	12 clicks
Sport	7 clicks

**i Info**

Turn clockwise to increase the damping; turn counter-clockwise to reduce damping when the shock absorber rebounds.

## 10.16 Handlebar position

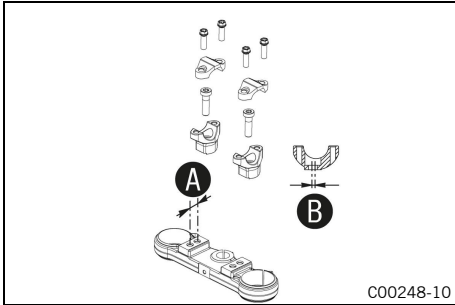

On the upper triple clamp, there are 2 holes at a distance of **A** to each other.

Hole distance A	15 mm (0.59 in)
-----------------	-----------------

The holes on the handlebar supports are placed at a distance of **B** from the center.

Hole distance B	3.5 mm (0.138 in)
-----------------	-------------------

The handlebar supports can be mounted in four different positions. This allows the handlebar to be mounted in the most comfortable position for the rider.

## 10.17 Adjusting the handlebar position



**Warning**

**Danger of accidents** A repaired handlebar poses a safety risk.

If the handlebar is bent or straightened, the material becomes fatigued. The handlebar may break as a result.

- Change the handlebar if the handlebar is damaged or bent.

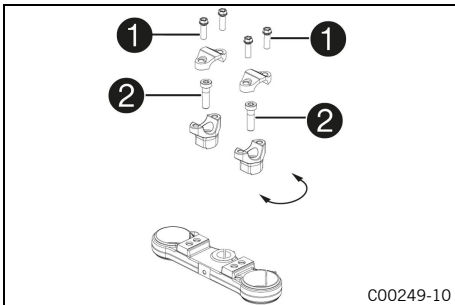

- Remove screws **1**. Take off the handlebar clamps. Remove the handlebar and lay it to one side.

**i Info**

Cover the components to protect them against damage. Do not kink the cables and lines.

- Remove screws **2**. Take off the handlebar support.
- Place the handlebar support in the required position. Mount and tighten screws **2**.

Guideline

Screw, handlebar support	M10	40 Nm (29.5 lbf ft) <b>Loctite®243™</b>
--------------------------	-----	--

- Position handlebar.

**i Info**

Make sure the cables and wiring are positioned correctly.

- Position handlebar clamps. Mount screws **1** and tighten evenly.

Guideline

Screw, handlebar clamp	M8	20 Nm (14.8 lbf ft)
------------------------	----	---------------------

**Info**

Make sure the gap widths are even.

---

## 11.1 Raising the motorcycle with a lift stand

### Note

**Danger of damage** The parked vehicle can roll away or fall over.

- Park the vehicle on a firm and level surface.

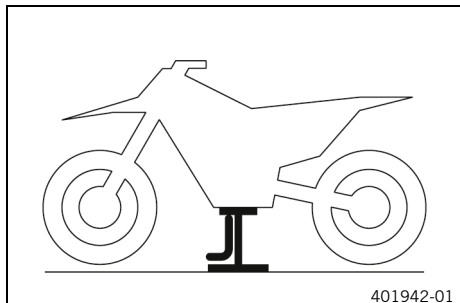

- Raise the motorcycle at the frame underneath the engine.

Lift stand (78929955100)

- ✓ Neither wheel is in contact with the ground.
- Secure the motorcycle against falling over.

## 11.2 Removing the motorcycle from the lift stand

### Note

**Danger of damage** The parked vehicle can roll away or fall over.

- Park the vehicle on a firm and level surface.

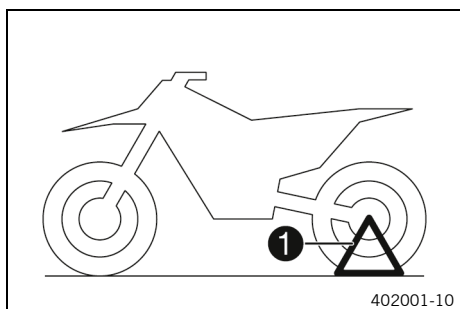

- Remove the motorcycle from the lift stand.
- Remove the lift stand.
- To park the motorcycle, insert plug-in stand ① into the left side of the wheel spindle.

### Info

Remove the plug-in stand before riding.

## 11.3 Bleeding the fork legs

### Preparatory work

- Raise the motorcycle with a lift stand. (📖 p. 44)

### Main work

- Release bleeder screws ①.
- ✓ Any excess pressure escapes from the interior of the fork.
- Tighten the bleeder screws.

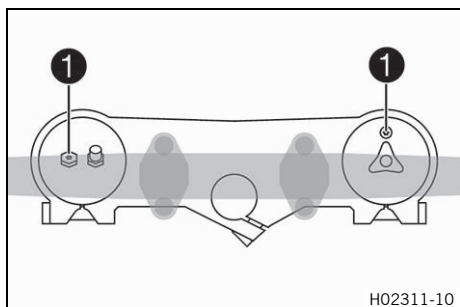

### Finishing work

- Remove the motorcycle from the lift stand. (📖 p. 44)

## 11.4 Cleaning the dust boots of the fork legs

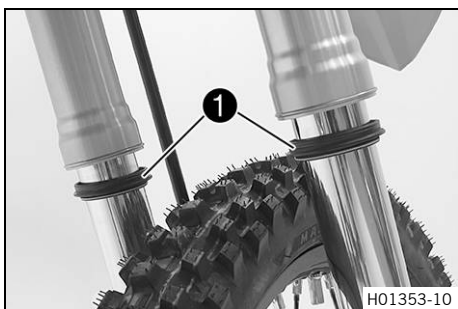

### Preparatory work

- Raise the motorcycle with a lift stand. (📖 p. 44)
- Remove the fork protector. (📖 p. 47)

### Main work

- Push dust boots ❶ of both fork legs downward.



### Info

The dust boots remove dust and coarse dirt particles from the inside fork tubes. Over time, dirt can accumulate behind the dust boots. If this dirt is not removed, the oil seals behind can start to leak.



### Warning

**Danger of accidents** Oil or grease on the brake discs reduces the braking effect.

- Always keep the brake discs free of oil and grease.
- Clean the brake discs with brake cleaner when necessary.

- Clean and oil the dust boots and inner fork tubes of both fork legs.

Universal oil spray (📖 p. 125)

- Press the dust boots back into their installation position.
- Remove excess oil.

### Finishing work

- Install the fork protector. (📖 p. 47)
- Remove the motorcycle from the lift stand. (📖 p. 44)

## 11.5 Removing the fork legs

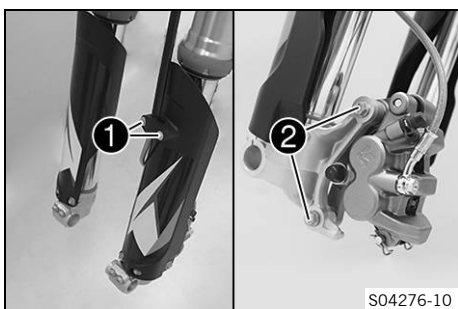

### Preparatory work

- Raise the motorcycle with a lift stand. (📖 p. 44)
- Remove the front wheel. (📖 p. 84)

### Main work

- Remove screws ❶ and take off the clamp.
- Remove screws ❷.
- Allow the brake caliper and the brake line to hang loosely to the side.



### Info

Do not kink the brake line.  
Do not operate the hand brake lever if the brake caliper has been removed.

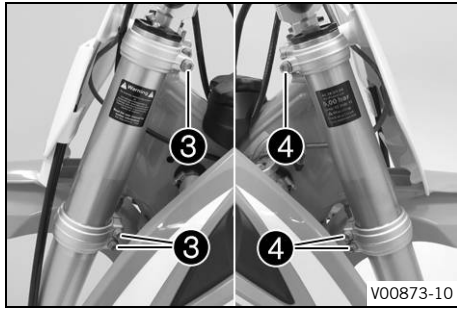

- Loosen screws **3**. Remove the left fork leg.
- Loosen screws **4**. Remove the right fork leg.

## 11.6 Installing the fork legs

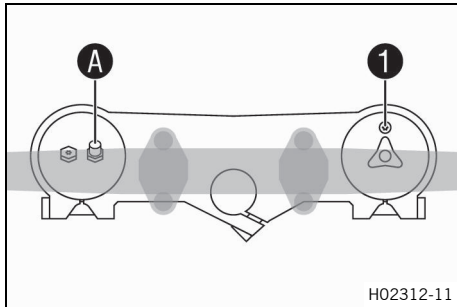

- Position the fork legs.
  - ✓ Air bleeder screw **1** of the right fork leg is positioned to the front.
  - ✓ Valve **A** of the left fork leg faces the front.



### Info

The second milled groove (from the top) must be flush with the upper edge of the upper triple clamp. The air suspension is located in the left fork leg. The pressure and rebound damping is located in the right fork leg.

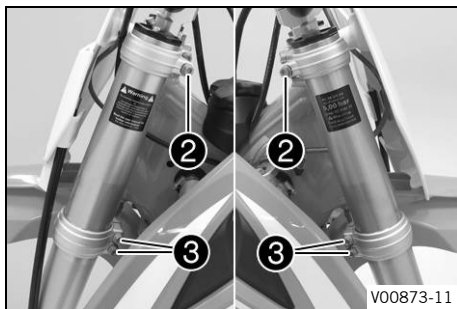

- Tighten screws **2**.

Guideline

Screw, top triple clamp	M8	17 Nm (12.5 lbf ft)
-------------------------	----	---------------------

- Tighten screws **3**.

Guideline

Screw, bottom triple clamp	M8	15 Nm (11.1 lbf ft)
----------------------------	----	---------------------

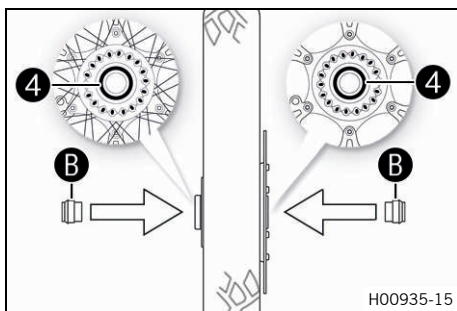

- Check the wheel bearing for damage and wear.
  - » If the wheel bearing is damaged or worn:
    - Change front wheel bearing.
- Clean and grease shaft seal rings **4** and contact surfaces **B** of the spacers.

Long-life grease (p. 124)

- Insert the spacers.

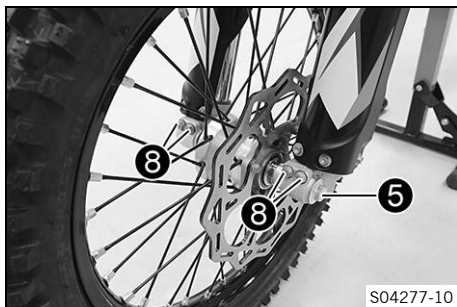

- Clean and grease the wheel spindle.

Long-life grease (p. 124)

- Position the front wheel.
- Insert the wheel spindle.
- Mount and tighten screw **5**.

Guideline

Screw, front wheel spindle	M20x1.5	35 Nm (25.8 lbf ft)
----------------------------	---------	---------------------



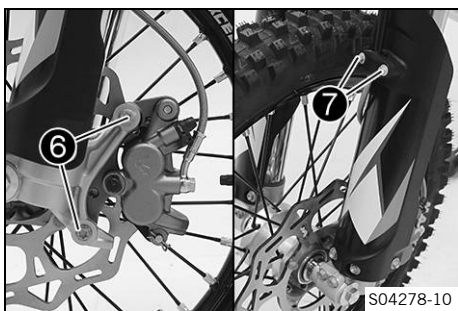

- Position the brake caliper.
- Mount and tighten screws **6**.

Guideline

Screw, front brake caliper	M8	25 Nm (18.4 lbf ft) <b>Loctite®243™</b>
----------------------------	----	--

- Position the brake line and the clamp. Mount and tighten screws **7**.
- Remove the motorcycle from the lift stand. (📖 p. 44)
- Operate the front brake and compress the fork a few times firmly.
- ✓ The fork legs straighten.
- Tighten screws **8**.

Guideline

Screw, fork stub	M8	15 Nm (11.1 lbf ft)
------------------	----	---------------------

## 11.7 Removing the fork protector

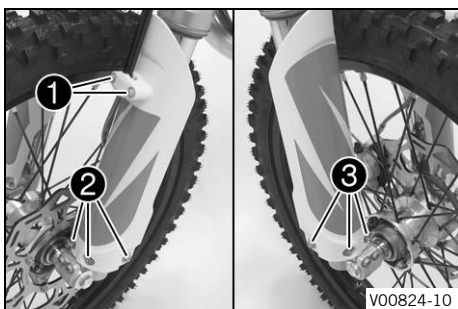

- Remove screws **1** and take off the clamp.
- Remove screws **2** on the left fork leg. Take off the fork protector.
- Remove screws **3** on the right fork leg. Take off the fork protector.

## 11.8 Installing the fork protector

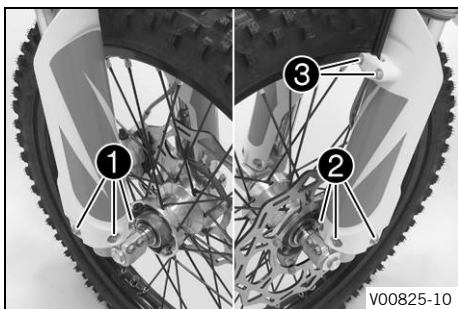

- Position the fork protector on the right fork leg. Mount and tighten screws **1**.

Guideline

Remaining screws, chassis	M6	10 Nm (7.4 lbf ft)
---------------------------	----	--------------------

- Position the fork protector on the left fork leg. Mount and tighten screws **2**.

Guideline

Remaining screws, chassis	M6	10 Nm (7.4 lbf ft)
---------------------------	----	--------------------

- Position the brake line and clamp. Mount and tighten screws **3**.

## 11.9 Removing the lower triple clamp

### Preparatory work

- Raise the motorcycle with a lift stand. (p. 44)
- Remove the front wheel. (p. 84)
- Remove the fork legs. (p. 45)
- Remove the start number plate. (p. 53)
- Remove front fender. (p. 54)
- Remove the handlebar cushion.

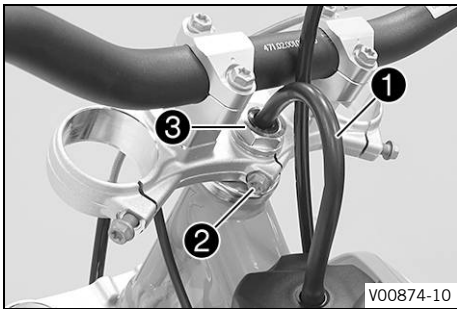

### Main work

- Pull fuel tank breather ① out of the steering stem.
- Loosen screw ②. Remove nut ③, pull off the upper triple clamp with the handlebar in an upward direction, and hang it to the side.



### Info

Cover the components to protect them against damage. Do not kink the cables and lines.

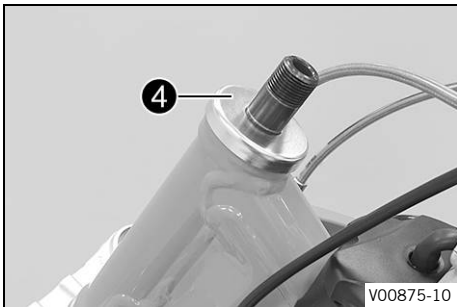

- Remove protective ring ④.
- Take off the lower triple clamp with the steering stem in a downward direction.
- Remove the upper steering head bearing.

## 11.10 Installing the lower triple clamp

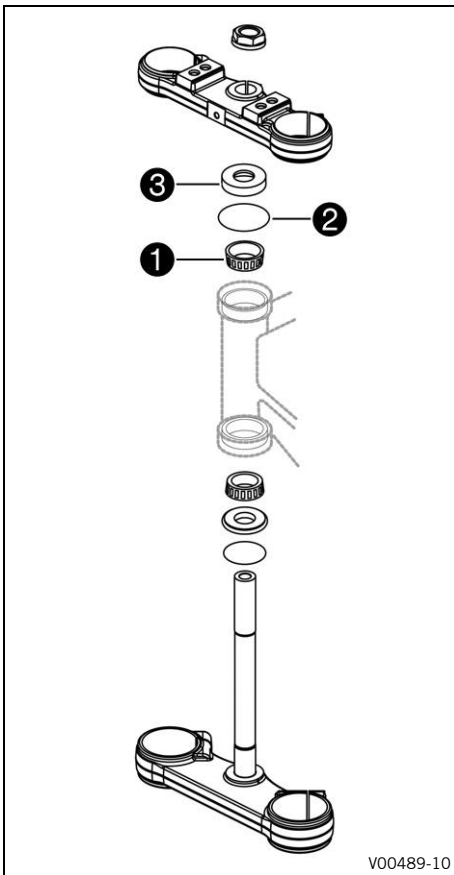

### Main work

- Clean the bearing and sealing elements, check for damage, and grease.

High viscosity grease (📖 p. 124)

- Insert the lower triple clamp with the steering stem. Mount upper steering head bearing ①.
- Slide on O-ring ②.
- Position protective ring ③.

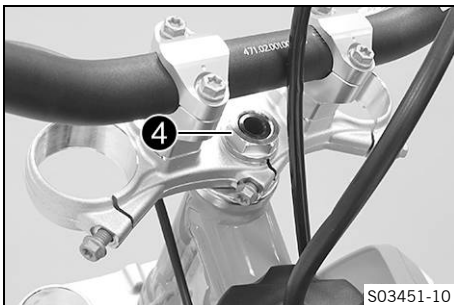

- Position the upper triple clamp with the handlebar.
- Mount nut ④, but do not tighten yet.

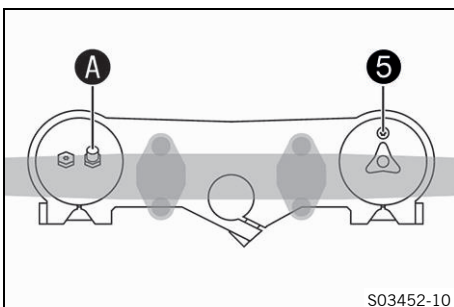

- Position the fork legs.
  - ✓ Air bleeder screw ⑤ of the right fork leg is positioned to the front.
  - ✓ Valve A of the left fork leg faces the front.

### Info

The second milled groove (from the top) must be flush with the upper edge of the upper triple clamp.

The air suspension is located in the left fork leg. The rebound and compression damping is located in the right fork leg.

# 11 SERVICE WORK ON THE CHASSIS

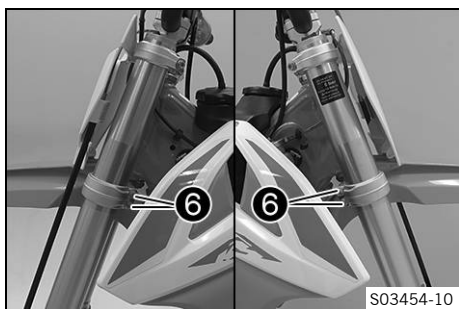

- Tighten screws **6**.

Guideline

Screw, bottom triple clamp	M8	15 Nm (11.1 lbf ft)
----------------------------	----	---------------------

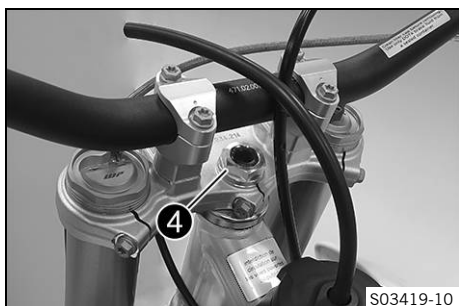

- Tighten nut **4**.

Guideline

Nut, steering stem	M20x1.5	10 Nm (7.4 lbf ft)
--------------------	---------	--------------------



- Position the fuel tank breather in the steering stem.
- Tighten screw **7**.

Guideline

Steering stem clamp screw	M8	20 Nm (14.8 lbf ft)
---------------------------	----	---------------------

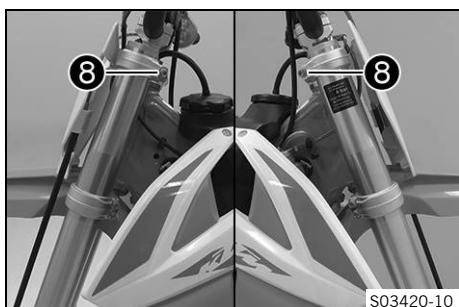

- Using a plastic hammer, tap lightly on the upper triple clamp to avoid stresses.
- Tighten screws **8**.

Guideline

Screw, top triple clamp	M8	17 Nm (12.5 lbf ft)
-------------------------	----	---------------------

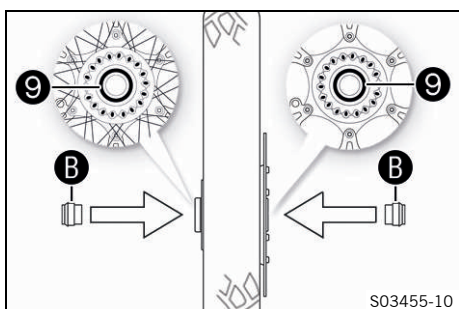

- Check the wheel bearing for damage and wear.
  - » If the wheel bearing is damaged or worn:
    - Change front wheel bearing. 🛠️
- Clean and grease shaft seal rings **9** and contact surfaces **B** of the spacers.

Long-life grease (🛠️ p. 124)
------------------------------

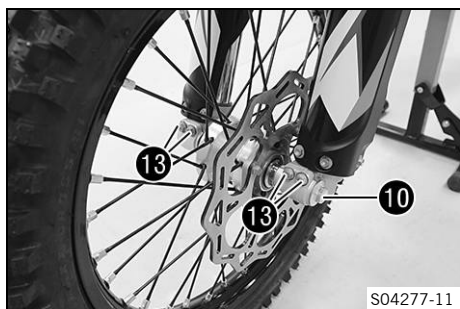

- Clean and grease the wheel spindle.

Long-life grease (📖 p. 124)
-----------------------------

- Position the front wheel.
- Insert the wheel spindle.
- Mount and tighten screw 10.

Guideline

Screw, front wheel spindle	M20x1.5	35 Nm (25.8 lbf ft)
----------------------------	---------	---------------------

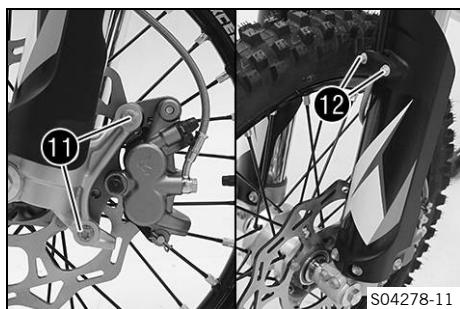

- Position the brake caliper.
- Mount and tighten screws 11.

Guideline

Screw, front brake caliper	M8	25 Nm (18.4 lbf ft) <b>Loctite®243™</b>
----------------------------	----	--

- Position the brake line and the clamp. Mount and tighten screws 12.
- Remove the motorcycle from the lift stand. (📖 p. 44)
- Operate the front brake and compress the fork a few times firmly.
- ✓ The fork legs straighten.

- Tighten screws 13.

Guideline

Screw, fork stub	M8	15 Nm (11.1 lbf ft)
------------------	----	---------------------

### Finishing work

- Install front fender. (📖 p. 54)
- Install the start number plate. (📖 p. 53)
- Check that the wiring harness, throttle cables, and brake and clutch lines can move freely and are routed correctly.
- Check the steering head bearing play. (📖 p. 51)
- Remove the motorcycle from the lift stand. (📖 p. 44)
- Position the handlebar cushion and secure with a cable tie.



## 11.11 Checking the steering head bearing play



### Warning

**Danger of accidents** Incorrect steering head bearing play impairs the handling characteristic and damages components.

- Correct incorrect steering head bearing play immediately. (Your authorized KTM workshop will be glad to help.)



### Info

If the vehicle is operated for a lengthy period with play in the steering head bearing, the bearings and the bearing seats in the frame can become damaged over time.

### Preparatory work

- Raise the motorcycle with a lift stand. (📖 p. 44)

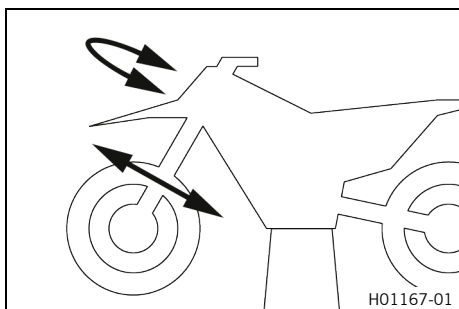

## Main work

- Move the handlebar to the straight-ahead position. Move the fork legs to and fro in the direction of travel.

Play should not be detectable on the steering head bearing.

- » If there is detectable play:
  - Adjust the steering head bearing play. 🛠️ (📖 p. 52)
- Move the handlebar to and fro over the entire steering range.

It must be possible to move the handlebar easily over the entire steering range. There should be no detectable detent positions.

- » If detent positions are detected:
  - Adjust the steering head bearing play. 🛠️ (📖 p. 52)
  - Check the steering head bearing and replace if required.

## Finishing work

- Remove the motorcycle from the lift stand. (📖 p. 44)

## 11.12 Adjusting the steering head bearing play 🛠️

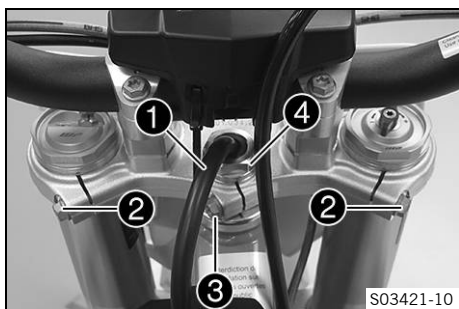

### Preparatory work

- Raise the motorcycle with a lift stand. (📖 p. 44)

### Main work

- Pull fuel tank breather ❶ out of the steering stem.
- Loosen screws ❷.
- Loosen screw ❸.
- Loosen and retighten nut ❹.

#### Guideline

Nut, steering stem	M20x1.5	10 Nm (7.4 lbf ft)
--------------------	---------	--------------------

- Using a plastic hammer, tap lightly on the upper triple clamp to avoid stresses.
- Tighten screw ❸.

#### Guideline

Steering stem clamp screw	M8	20 Nm (14.8 lbf ft)
---------------------------	----	---------------------

- Tighten screws ❷.

#### Guideline

Screw, top triple clamp	M8	17 Nm (12.5 lbf ft)
-------------------------	----	---------------------

- Position the fuel tank breather ❶ in the steering stem.

### Finishing work

- Check the steering head bearing play. (📖 p. 51)
- Remove the motorcycle from the lift stand. (📖 p. 44)

## 11.13 Lubricating the steering head bearing

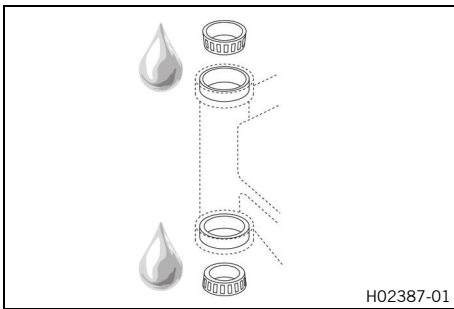

- Remove the lower triple clamp. (p. 48)
- Install the lower triple clamp. (p. 49)



### Info

The steering head bearing is cleaned and lubricated in the course of removal and installation of the lower triple clamp.

## 11.14 Removing the start number plate

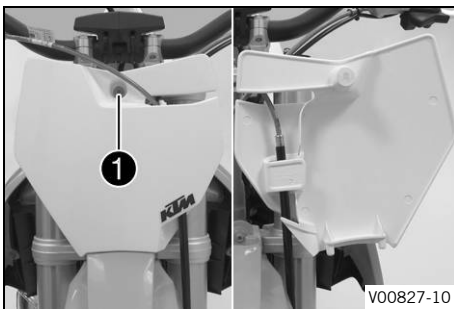

- Remove screw 1.
- Unhook the start number plate from the brake line and remove it.

## 11.15 Installing the start number plate

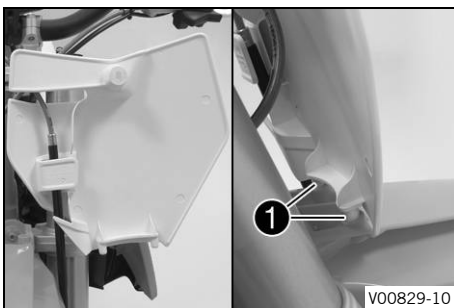

- Attach the start number plate to the brake line.
- Position the start number plate.
- ✓ Holding lugs 1 engage in the fender.

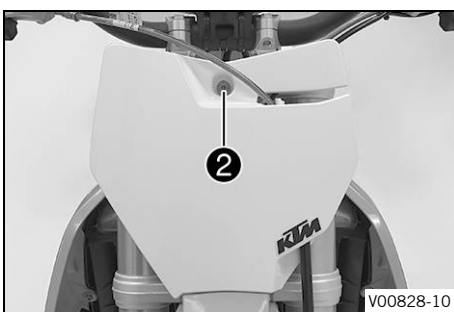

- Mount and tighten screw 2.

### Guideline

Start number plate screw	M6	4 Nm (3 lbf ft)
--------------------------	----	-----------------

## 11.16 Removing front fender

### Preparatory work

- Remove the start number plate. (📖 p. 53)

### Main work

- Remove screws ❶.
- Remove screws ❷. Take off the front fender.

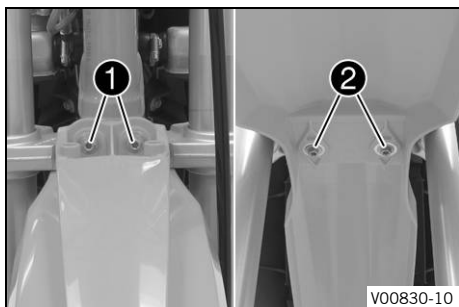

## 11.17 Installing front fender

### Main work

- Position front fender.
- Mount and tighten screws ❶.

#### Guideline

Screw, front fender	M6	6 Nm (4.4 lbf ft)
---------------------	----	-------------------

- Mount and tighten screws ❷.

#### Guideline

Screw, front fender	M6	6 Nm (4.4 lbf ft)
---------------------	----	-------------------

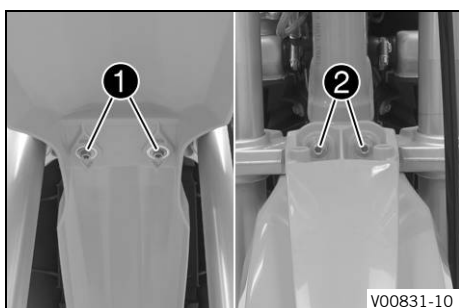

### Finishing work

- Install the start number plate. (📖 p. 53)

## 11.18 Removing the shock absorber

### Preparatory work

- Raise the motorcycle with a lift stand. (📖 p. 44)

### Main work

- Detach the brake line from the brake line guide.
- Remove screw ❶ and lower the rear wheel with the link fork as far as possible without blocking the rear wheel. Secure the rear wheel in this position.
- Remove screw ❷, push splash protector ❸ to the side, and remove the shock absorber.

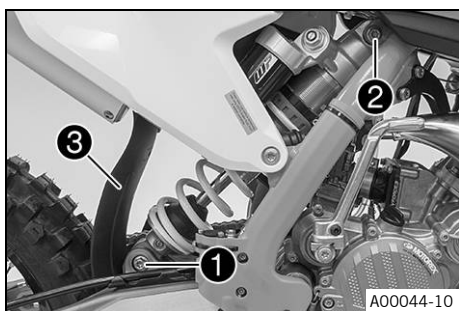



## 11.19 Installing the shock absorber

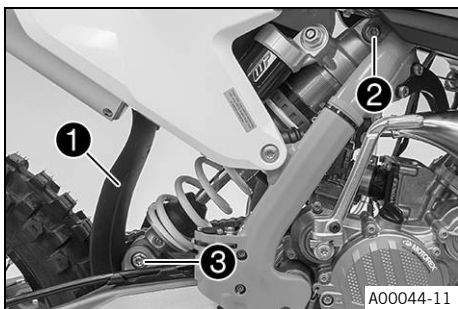

### Main work

- Push splash protector **1** to the side and position the shock absorber. Mount and tighten screw **2**.

### Guideline

Screw, top shock absorber	M12	60 Nm (44.3 lbf ft) <b>Loctite®2701™</b>
---------------------------	-----	---

- Mount and tighten screw **3**.

### Guideline

Screw, bottom shock absorber	M12	60 Nm (44.3 lbf ft) <b>Loctite®2701™</b>
------------------------------	-----	---

- Attach brake line.

### Finishing work

- Remove the motorcycle from the lift stand. (📖 p. 44)



## 11.20 Removing the seat

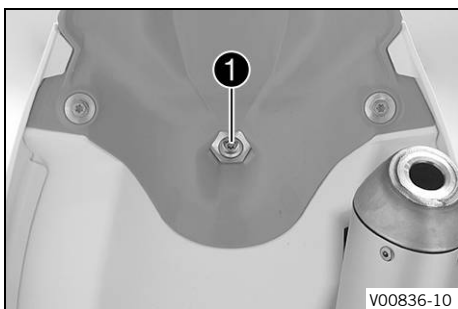

- Remove screw **1**.
- Raise the rear of the seat, pull the seat back, and lift it off.



## 11.21 Mounting the seat



- Mount the front of the seat on the collar bushing of the fuel tank, lower the seat at the rear, and push the seat forward.
- Make sure that the seat is correctly locked in.

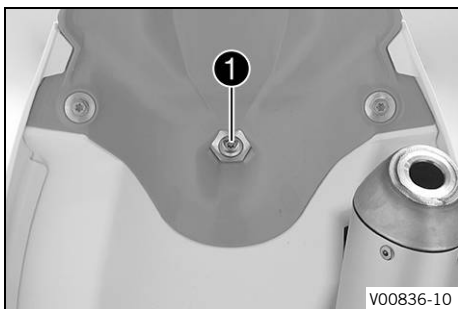

- Mount and tighten screw **1** of the seat fixing.

### Guideline

Remaining screws, chassis	M6	10 Nm (7.4 lbf ft)
---------------------------	----	--------------------



## 11.22 Removing the air filter box cover

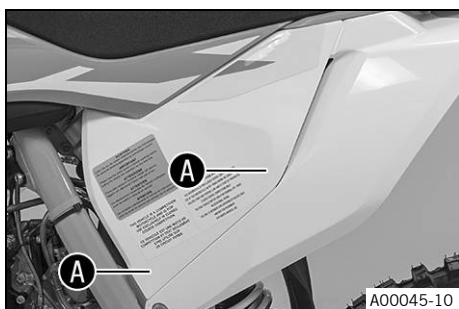

- Pull off the air filter box cover laterally in areas **A** and take it off toward the front.

## 11.23 Installing the air filter box cover

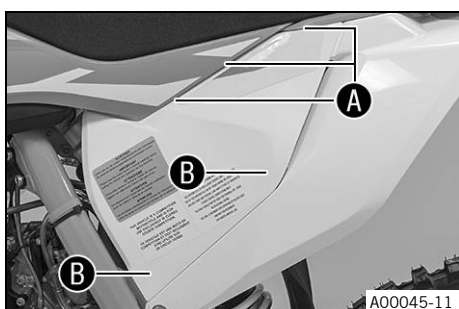

- Attach the air filter box cover in areas **A** and snap it into place in areas **B**.

## 11.24 Removing the air filter

### Note

**Engine damage** Unfiltered intake air has a negative effect on the service life of the engine.

Dust and dirt will enter the engine without an air filter.

- Only operate the vehicle if it is equipped with an air filter.



### Note

**Environmental hazard** Hazardous substances cause environmental damage.

- Dispose of oils, grease, filters, fuel, cleaning agents, brake fluid, etc., correctly and in compliance with the applicable regulations.

### Preparatory work

- Remove the air filter box cover. (📖 p. 56)

### Main work

- Detach retaining tab **1**. Remove air filter with air filter support.
- Remove air filter from air filter support.

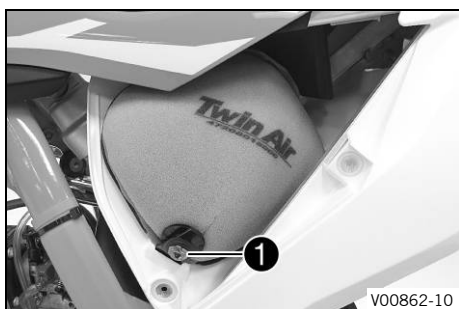

## 11.25 Cleaning the air filter and air filter box ↴



### Note

**Environmental hazard** Hazardous substances cause environmental damage.

- Dispose of oils, grease, filters, fuel, cleaning agents, brake fluid, etc., correctly and in compliance with the applicable regulations.



### Info

Do not clean the air filter with fuel or petroleum since these substances attack the foam.



### Preparatory work

- Remove the air filter box cover. (🔧 p. 56)
- Remove the air filter. ↴ (🔧 p. 56)

### Main work

- Wash the air filter thoroughly in special cleaning liquid and allow it to dry properly.

Air filter cleaner (🔧 p. 124)



### Info

Only press the air filter to dry it, never wring it out.

- Oil the dry air filter with a high-grade air filter oil.

Oil for foam air filter (🔧 p. 124)

- Clean the air filter box.
- Check intake flange for damage and looseness.

### Finishing work

- Install the air filter. ↴ (🔧 p. 57)
- Install the air filter box cover. (🔧 p. 56)



## 11.26 Installing the air filter ↴

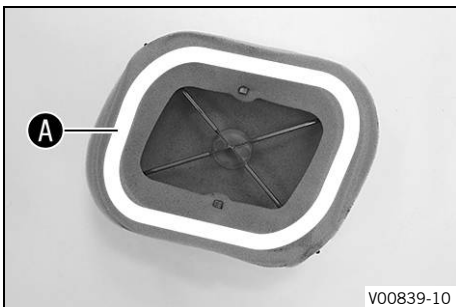

### Main work

- Mount the clean air filter on the air filter support.
- Grease the air filter in area **A**.

Long-life grease (🔧 p. 124)

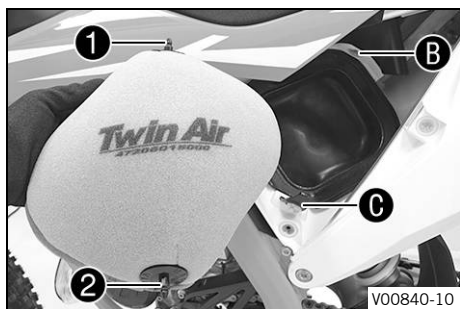

- Insert the air filter and position top retaining pin **1** in bushing **B**.  
 ✓ The air filter is correctly positioned.
- Secure the bottom retaining pin **2** with holding tab **C**.

**i Info**  
 If the air filter is not mounted correctly, dust and dirt may enter the engine and result in damage.

### Finishing work

- Install the air filter box cover. (📖 p. 56)

## 11.27 Removing the main silencer



### Warning

**Danger of burns** The exhaust system gets very hot when the vehicle is driven.

- Allow the exhaust system to cool down before performing any work on the vehicle.

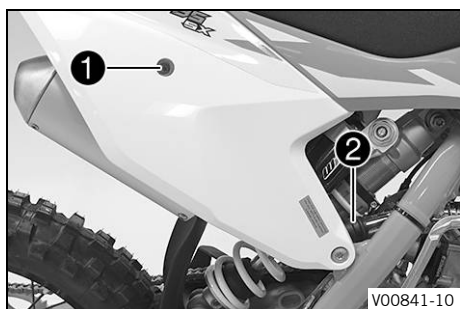

- Remove screw **1**.
- Pull off the main silencer from the manifold at exhaust sleeve **2**.

## 11.28 Installing the main silencer

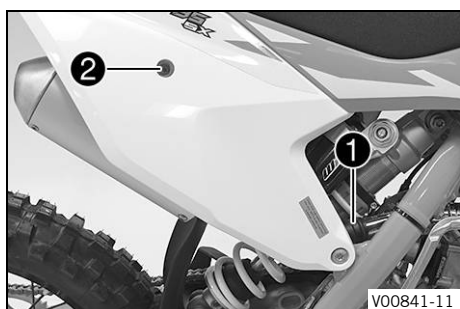

- Mount the main silencer with exhaust sleeve **1**.
- Mount and tighten screw **2**.

### Guideline

Remaining screws, chassis	M6	10 Nm (7.4 lbf ft)
---------------------------	----	--------------------

## 11.29 Changing the glass fiber yarn filling of the main silencer ↗



### Warning

**Danger of burns** The exhaust system gets very hot when the vehicle is driven.

- Allow the exhaust system to cool down before performing any work on the vehicle.

**i Info**

Over time, the fibers of the rock wool dissipate and the silencer “burns out”. Not only is the noise level higher, the performance characteristics change.

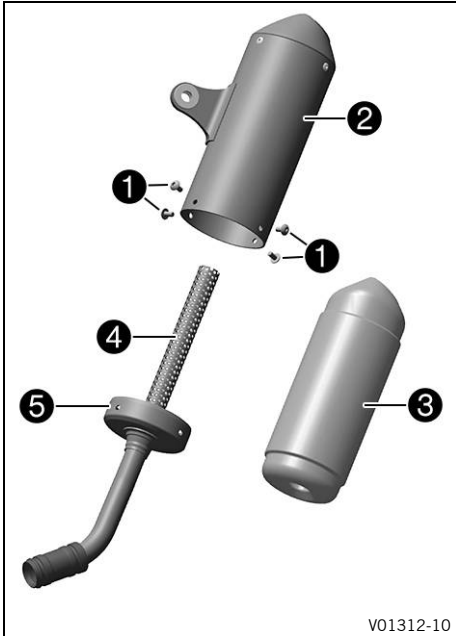

V01312-10

**Preparatory work**

- Remove main silencer. (📖 p. 58)

**Main work**

- Remove screws ①.
- Take off outer tube ②.
- Remove glass fiber yarn filling ③ from inner tube ④.
- Clean the parts that need to be reinstalled and check for damage.
- Mount the new glass fiber yarn filling on the inner tube.

**i Info**

Mount the glass fiber yarn filling so that the thermal protection foil is positioned on the right in the direction of travel.

- Slide outer tube over the inner tube with the new glass fiber yarn filling.

**i Info**

Seal the connecting cap ⑤ to the outer tube with silicone.

- Mount and tighten the screws.

**Guideline**

Screw, main silencer	M5	7 Nm (5.2 lbf ft)
----------------------	----	-------------------

**Finishing work**

- Install the main silencer. (📖 p. 58)



## 11.30 Removing the fuel tank ↩



**Danger**

**Fire hazard** Fuel is highly flammable.

The fuel in the fuel tank expands when warm and can escape if overfilled.

- Do not fuel the vehicle in the vicinity of open flames or lit cigarettes.
- Switch off the engine for refueling.
- Make sure that no fuel is spilled; particularly not on hot parts of the vehicle.
- If any fuel is spilled, wipe it off immediately.
- Observe the specifications for refueling.



## Warning

**Danger of poisoning** Fuel is poisonous and a health hazard.

- Avoid skin, eye and clothing contact with fuel.
- Immediately consult a doctor if you swallow fuel.
- Do not inhale fuel vapors.
- In case of skin contact, rinse the affected area with plenty of water.
- Rinse the eyes thoroughly with water, and consult a doctor in case of fuel contact with the eyes.
- Change your clothing in case of fuel spills on them.
- Keep fuels correctly in a suitable canister, and out of the reach of children.

## Preparatory work

- Remove the seat. (📖 p. 55)
- Turn tap handle of the fuel tap to the **OFF** position.

## Main work

- Pull off the fuel hose.



## Info

Remaining fuel may flow out of the fuel hose.

- Remove screws ①.

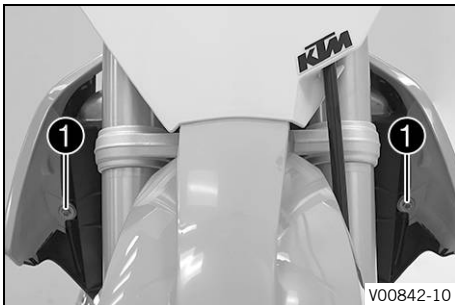

- Remove screw ② with the rubber bushing.
- Remove the hose from the fuel tank breather.

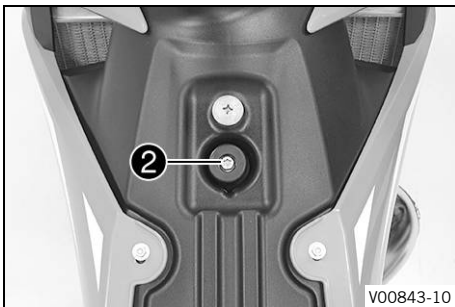

- Pull both spoilers off laterally from the radiator bracket and lift off the fuel tank.

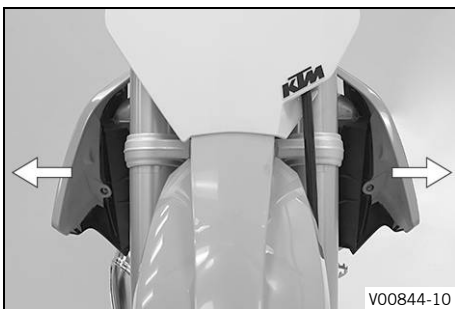

## 11.31 Installing the fuel tank 🛠️



### Danger

**Fire hazard** Fuel is highly flammable.

The fuel in the fuel tank expands when warm and can escape if overfilled.

- Do not fuel the vehicle in the vicinity of open flames or lit cigarettes.
- Switch off the engine for refueling.
- Make sure that no fuel is spilled; particularly not on hot parts of the vehicle.
- If any fuel is spilled, wipe it off immediately.
- Observe the specifications for refueling.



### Warning

**Danger of poisoning** Fuel is poisonous and a health hazard.

- Avoid skin, eye and clothing contact with fuel.
- Immediately consult a doctor if you swallow fuel.
- Do not inhale fuel vapors.
- In case of skin contact, rinse the affected area with plenty of water.
- Rinse the eyes thoroughly with water, and consult a doctor in case of fuel contact with the eyes.
- Change your clothing in case of fuel spills on them.
- Keep fuels correctly in a suitable canister, and out of the reach of children.

### Main work

- Check the throttle cable routing. (📖 p. 67)
- Position the fuel tank and fit the two spoilers to the sides of the radiator mount.
- Make sure that no cables or throttle cables are trapped or damaged.

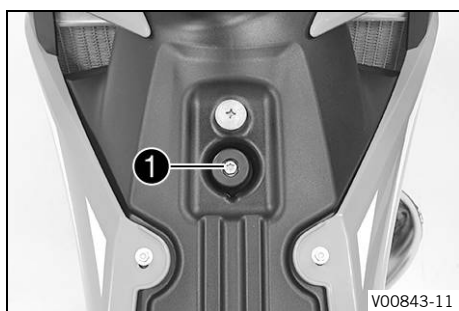
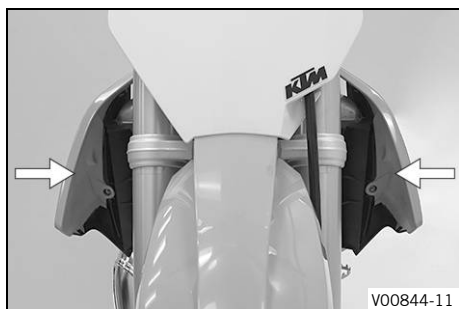

- Mount and tighten screw **1** with the rubber bushing.

### Guideline

Remaining screws, chassis	M6	10 Nm (7.4 lbf ft)
---------------------------	----	--------------------

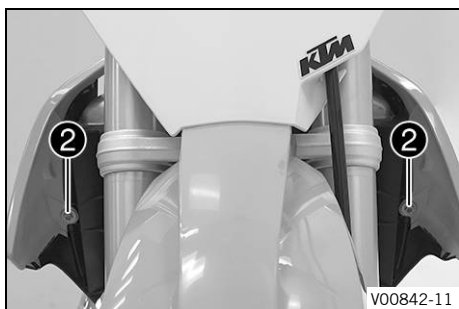

- Mount and tighten screws ②.

Guideline

Remaining screws, chassis	M6	10 Nm (7.4 lbf ft)
---------------------------	----	--------------------

- Mount fuel hose.
- Position the fuel tank breather in the steering stem.

### Finishing work

- Mount the seat. (📖 p. 55)

## 11.32 Checking for chain dirt accumulation

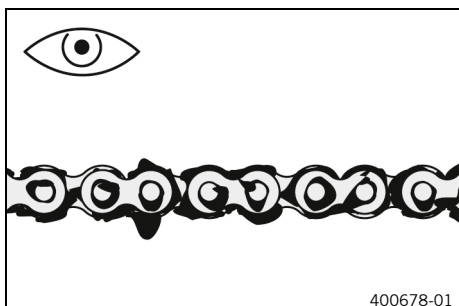

- Check the chain for coarse dirt accumulation.
  - » If the chain is very dirty:
    - Clean the chain. (📖 p. 62)

## 11.33 Cleaning the chain



### Warning

**Danger of accidents** Lubricants on the tires reduces the road grip.

- Remove lubricants from the tires using a suitable cleaning agent.



### Warning

**Danger of accidents** Oil or grease on the brake discs reduces the braking effect.

- Always keep the brake discs free of oil and grease.
- Clean the brake discs with brake cleaner when necessary.



### Note

**Environmental hazard** Hazardous substances cause environmental damage.

- Dispose of oils, grease, filters, fuel, cleaning agents, brake fluid, etc., correctly and in compliance with the applicable regulations.



### Info

The service life of the chain depends largely on its maintenance.

### Preparatory work

- Raise the motorcycle with a lift stand. (📖 p. 44)



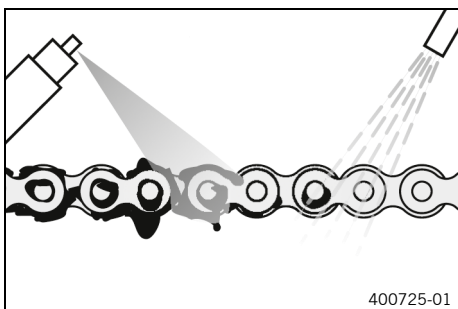

### Main work

- Rinse off loose dirt with a soft jet of water.
- Remove old grease residue with chain cleaner.

Chain cleaner (📖 p. 124)

- After drying, apply chain spray.

Off-road chain spray (📖 p. 124)

### Finishing work

- Remove the motorcycle from the lift stand. (📖 p. 44)

## 11.34 Checking the chain tension



### Warning

**Danger of accidents** Incorrect chain tension damages components and results in accidents.

If the chain is tensioned too much, the chain, engine sprocket, rear sprocket, transmission and rear wheel bearings wear more quickly. Some components may break if overloaded.

If the chain is too loose, the chain may fall off the engine sprocket or the rear sprocket. As a result, the rear wheel locks or the engine will be damaged.

- Check the chain tension regularly.
- Set the chain tension in accordance with the specification.

### Preparatory work

- Raise the motorcycle with a lift stand. (📖 p. 44)

### Main work

- Pull the chain at the end of the chain sliding guard upward to measure chain tension **A**.



### Info

Lower chain section **1** must be taut.

Chain wear is not always even, so you should repeat this measurement at different chain positions.

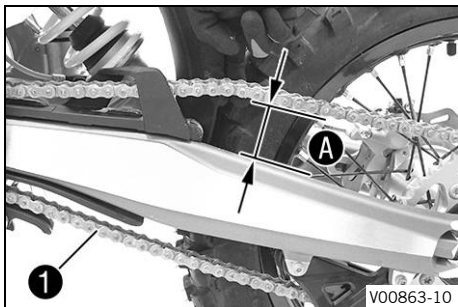

Chain tension	46 ... 49 mm (1.81 ... 1.93 in)
---------------	---------------------------------

- » If the chain tension does not meet the specification:

- Adjust the chain tension. (📖 p. 64)

### Finishing work

- Remove the motorcycle from the lift stand. (📖 p. 44)

## 11.35 Adjusting the chain tension



### Warning

**Danger of accidents** Incorrect chain tension damages components and results in accidents.

If the chain is tensioned too much, the chain, engine sprocket, rear sprocket, transmission and rear wheel bearings wear more quickly. Some components may break if overloaded.

If the chain is too loose, the chain may fall off the engine sprocket or the rear sprocket. As a result, the rear wheel locks or the engine will be damaged.

- Check the chain tension regularly.
- Set the chain tension in accordance with the specification.

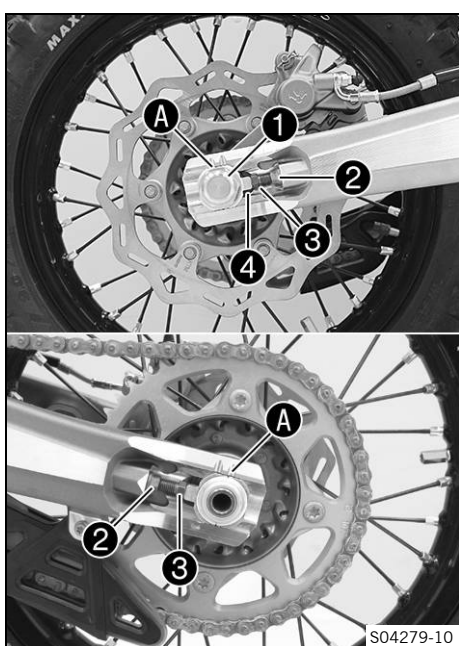

### Preparatory work

- Raise the motorcycle with a lift stand. (📖 p. 44)
- Check the chain tension. (📖 p. 63)

### Main work

- Loosen nut ①.
- Loosen nuts ②.
- Adjust the chain tension by turning adjusting screws ③ left and right.

#### Guideline

Chain tension	46 ... 49 mm (1.81 ... 1.93 in)
---------------	---------------------------------

Turn adjusting screws ③ on the left and right so that the markings on the left and right chain adjusters are in the same position relative to reference marks A. The rear wheel is then correctly aligned.

- Tighten nuts ②.
- Make sure that chain adjusters ④ are fitted correctly on adjusting screws ③.
- Tighten nut ①.

#### Guideline

Nut, rear wheel spindle	M20x1.5	80 Nm (59 lbf ft)
-------------------------	---------	-------------------



### Info

The wide adjustment range of the chain adjusters (32 mm (1.26 in)) enables different secondary ratios with the same chain length.

Chain adjusters ④ can be turned by 180°.

### Finishing work

- Remove the motorcycle from the lift stand. (📖 p. 44)

## 11.36 Checking the chain, rear sprocket, engine sprocket, and chain guide

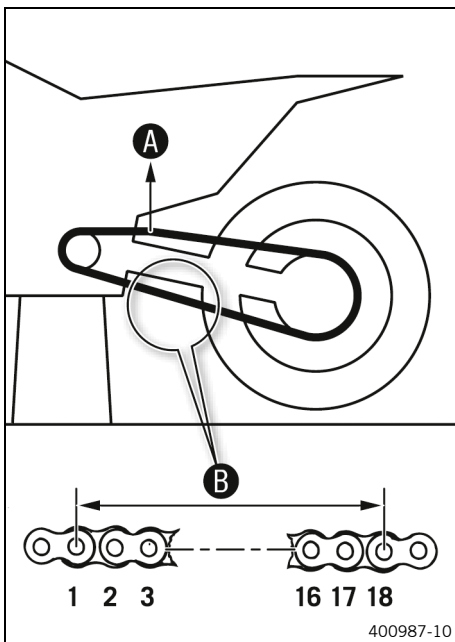
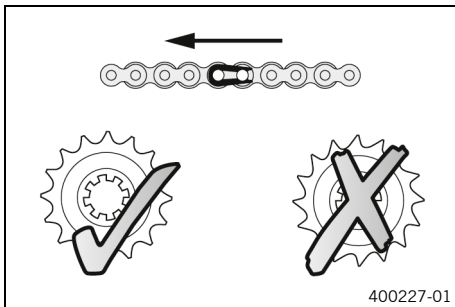

### Preparatory work

- Raise the motorcycle with a lift stand. (📖 p. 44)

### Main work

- Shift the transmission into neutral.
- Check the chain, rear sprocket, and engine sprocket for wear.
  - » If the chain, rear sprocket or engine sprocket is worn:
    - Change the drivetrain kit. 🛠️

### **i** Info

The engine sprocket, rear sprocket, and chain should always be replaced together.

- Pull on the top section of the chain with the specified weight **A**.

### Guideline

Weight, chain wear measurement	10 ... 15 kg (22 ... 33 lb.)
--------------------------------	------------------------------

- Measure distance **B** of 18 chain rollers in the lower chain section.

### **i** Info

Chain wear is not always even, so you should repeat this measurement at different chain positions.

Maximum distance <b>B</b> from 18 chain rollers at the longest chain section	219 mm (8.62 in)
--	------------------

- » If distance **B** is greater than the specified measurement:
  - Change the drivetrain kit. 🛠️

### **i** Info

When a new chain is mounted, the rear sprocket and engine sprocket should also be changed. New chains wear out faster on an old, worn rear sprocket or engine sprocket.



- Check the chain sliding guard for wear.
  - » If the lower edge of the chain pins is in line with, or below, the chain sliding guard:
    - Change the chain sliding guard. 🛠️
- Check that the chain sliding guard is firmly seated.
  - » If the chain sliding guard is loose:
    - Tighten screws on the chain sliding guard.

Guideline

Remaining screws, chassis	M6	10 Nm (7.4 lbf ft)
---------------------------	----	-----------------------

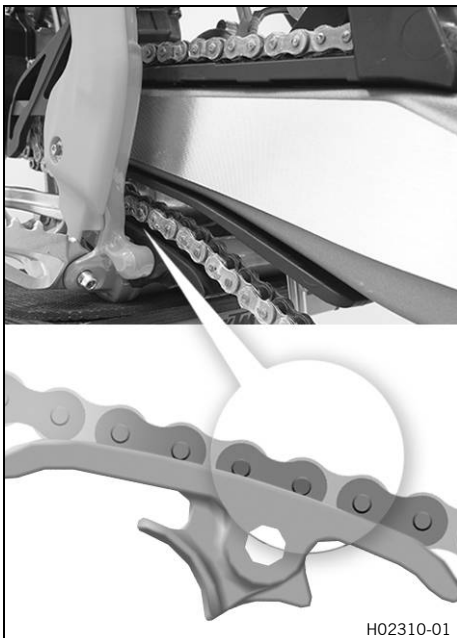

- Check the chain sliding piece for wear.
  - » If the lower edge of the chain pins is in line with or below the chain sliding piece:
    - Change the chain sliding piece. 🛠️
- Check that the chain sliding piece is firmly seated.
  - » If the chain sliding piece is loose:
    - Tighten screw on the chain sliding piece.

Guideline

Screw, chain sliding piece	M8	15 Nm (11.1 lbf ft)
----------------------------	----	------------------------

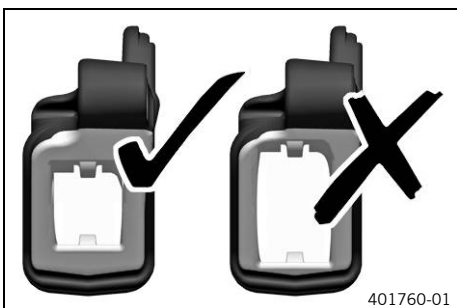

- Check the chain guide for wear.



**Info**

Wear can be seen on the front of the chain guide.

- » If the light part of the chain guide is worn:
  - Change the chain guide. 🛠️



- Check that the chain guide is firmly seated.
  - » If the chain guide is loose:
    - Tighten the screws on the chain guide.

Guideline

Remaining screws, chassis	M6	10 Nm (7.4 lbf ft)
---------------------------	----	-----------------------

### Finishing work

- Remove the motorcycle from the lift stand. (📖 p. 44)

## 11.37 Checking the frame 🛠️

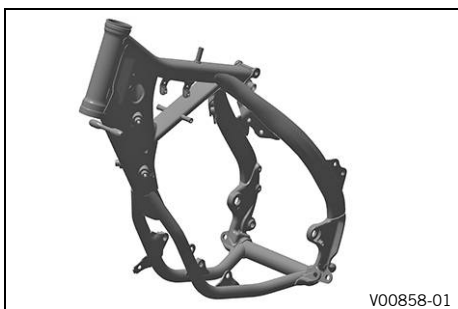

- Check the frame for damage, cracks, and deformation.
  - » If the frame shows signs of damage, cracks, or deformation:
    - Change the frame. 🛠️

Guideline

Repairs on the frame are not permitted.
---

## 11.38 Checking the link fork 🛠️



- Check the link fork for damage, cracking, and deformation.
  - » If the link fork shows signs of damage, cracking, or deformation:
    - Change the link fork. 🛠️

### Info

Always replace a damaged link fork. Repairing the link fork is not authorized by KTM.

## 11.39 Checking the throttle cable routing



### Warning

**Danger of accidents** The throttle cable may slip out of the guide if routed incorrectly.

The throttle slide will then no longer be closed and the speed can no longer be controlled.

- Make sure that the throttle cable routing and the play in throttle cable complies with the specification.

### Preparatory work

- Remove the seat. (📖 p. 55)
- Turn tap handle of the fuel tap to the **OFF** position.
- Remove the fuel tank. 🛠️ (📖 p. 59)

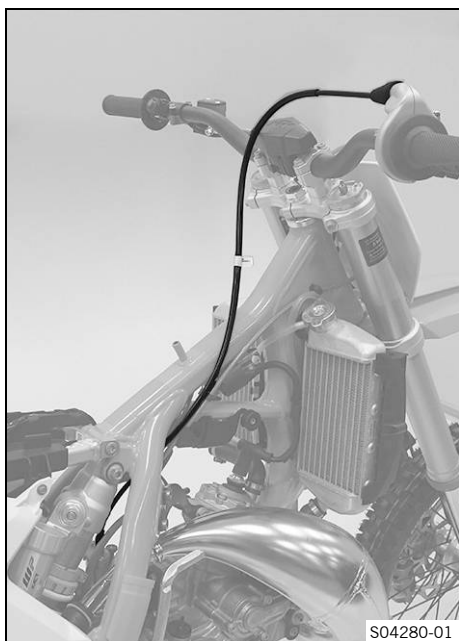

## Main work

- Check the throttle cable routing.

The throttle cable must be routed along the back of the handlebar, to the right of the frame, above the fuel tank bracket, and to the carburetor.

- » If the throttle cable is not routed as specified:
  - Correct the throttle cable routing.

## Finishing work

- Install the fuel tank. (🔧 📖 p. 61)
- Mount the seat. (📖 p. 55)

### 11.40 Checking the rubber grip

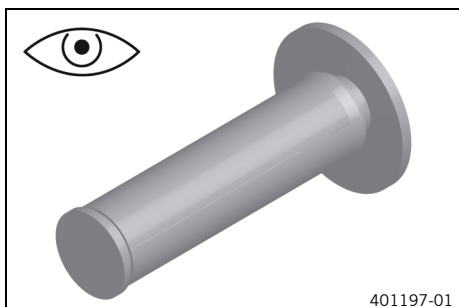

- Check the rubber grips on the handlebar for damage and wear and to ensure they are firmly seated.
  - » If a rubber grip is damaged, worn or loose:
    - Change and secure the rubber grip.

Rubber grip adhesive (00062030051) (📖 p. 125)

### 11.41 Adjusting the basic position of the clutch lever

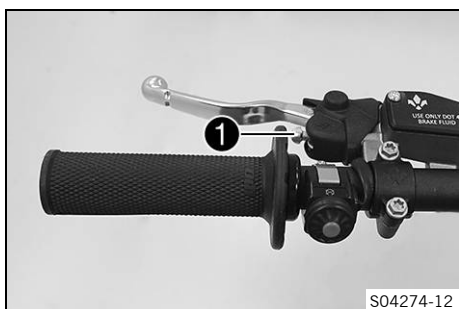

- Adjust the basic position of the clutch lever to the size of the rider's hand using adjusting screw ①.

#### **i** Info

Turn the adjusting screw clockwise to increase the distance between the clutch lever and the handlebar. Turn the adjusting screw counterclockwise to decrease the distance between the clutch lever and the handlebar.

The range of adjustment is limited.

Turn the adjusting screw by hand only, and do not apply any force.

Do not make any adjustments while riding.

## 11.42 Checking the fluid level of the hydraulic clutch

**i Info**  
The fluid level rises with increasing wear of the clutch facing discs.

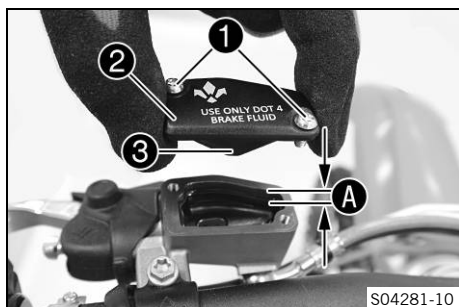

- Move the hydraulic clutch fluid reservoir mounted on the handlebar into a horizontal position.
- Remove screws ①.
- Take off cover ② with membrane ③.
- Check the fluid level.

**Guideline**

Level A (fluid level below container rim)	4 mm (0.16 in)
---	----------------

- » If the fluid has dropped below marking A in the level viewer:
  - Correct the fluid level of the hydraulic clutch. (📖 p. 69)
- Position the cover with the membrane. Mount and tighten the screws.

**i Info**  
Use water to immediately clean up any brake fluid that has overflowed or spilled.



## 11.43 Correcting the fluid level of the hydraulic clutch

**! Warning**  
**Skin irritation** Brake fluid causes skin irritation.

- Keep brake fluid out of the reach of children.
- Wear suitable protective clothing and safety glasses.
- Do not allow brake fluid to come into contact with the skin, the eyes or clothing.
- Consult a doctor immediately if brake fluid has been swallowed.
- Rinse the affected area with plenty of water in the event of contact with the skin.
- Rinse eyes thoroughly with water immediately and consult a doctor if brake fluid comes into contact with the eyes.
- If brake fluid spills on to your clothing, change the clothing.

**i Info**  
The fluid level rises with increasing wear of the clutch facing discs.  
Never use DOT 5 brake fluid. It is silicone-based and purple in color. Oil seals and clutch lines are not designed for DOT 5 brake fluid.  
Avoid contact between brake fluid and painted parts. Brake fluid attacks paint.  
Only use clean brake fluid from a sealed container.

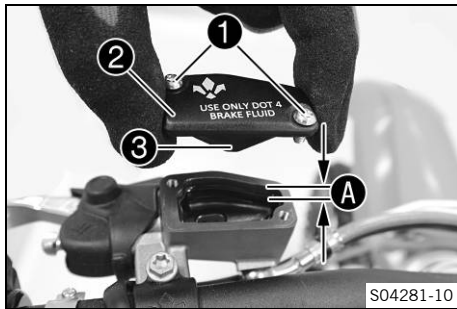

- Move the clutch fluid reservoir mounted on the handlebar to a horizontal position.
- Remove screws ①.
- Remove cover ② with membrane ③.
- Correct the fluid up to level A.

Guideline

Level A (fluid level below container rim)	4 mm (0.16 in)
---	----------------

Brake fluid DOT 4 / DOT 5.1 (📖 p. 122)

- Position the cover with the membrane. Mount and tighten the screws.



**Info**

Clean up overflowed or spilled brake fluid immediately with water.

## 11.44 Changing the hydraulic clutch fluid 🛠️



**Warning**

**Skin irritation** Brake fluid causes skin irritation.

- Keep brake fluid out of the reach of children.
- Wear suitable protective clothing and safety glasses.
- Do not allow brake fluid to come into contact with the skin, the eyes or clothing.
- Consult a doctor immediately if brake fluid has been swallowed.
- Rinse the affected area with plenty of water in the event of contact with the skin.
- Rinse eyes thoroughly with water immediately and consult a doctor if brake fluid comes into contact with the eyes.
- If brake fluid spills on to your clothing, change the clothing.



**Note**

**Environmental hazard** Hazardous substances cause environmental damage.

- Dispose of oils, grease, filters, fuel, cleaning agents, brake fluid, etc., correctly and in compliance with the applicable regulations.



**Info**

Never use DOT 5 brake fluid. It is silicone-based and purple in color. Oil seals and clutch lines are not designed for DOT 5 brake fluid.

Avoid contact between brake fluid and painted parts. Brake fluid attacks paint.

Only use clean brake fluid from a sealed container.



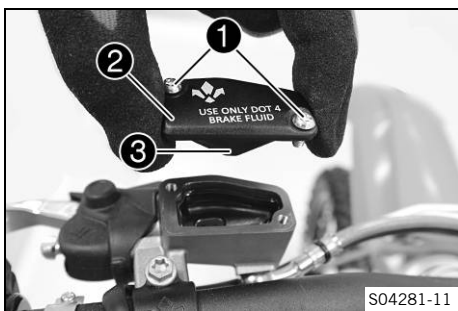

S04281-11

- Move the clutch fluid reservoir mounted on the handlebar to a horizontal position.
- Remove screws ①.
- Remove cover ② with membrane ③.

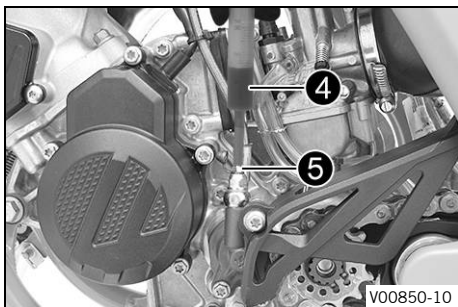

V00850-10

- Fill bleeding syringe ④ with the appropriate hydraulic fluid.

Syringe (50329050000)
-----------------------

Brake fluid DOT 4 / DOT 5.1 (📖 p. 122)
--

- On the clutch slave cylinder, remove bleeder screw ⑤ and mount bleeding syringe ④.

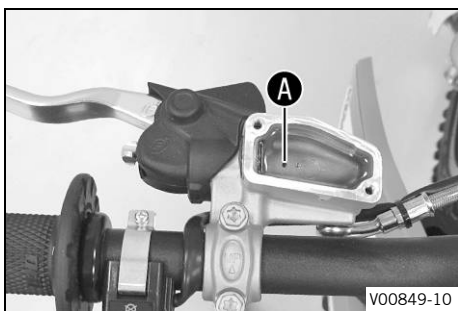

V00849-10

- Inject the liquid into the system until it escapes from opening A of the master cylinder without bubbles.
- Now and then, extract fluid from the master cylinder reservoir to prevent overflow.
- Remove the bleeding syringe. Mount and tighten screws bleeder screw.
- Correct the fluid level of the hydraulic clutch.

Guideline

Fluid level below container rim	4 mm (0.16 in)
---------------------------------	----------------

- Position the cover with the membrane. Mount and tighten the screws.

**i** Info

Clean up overflowed or spilled brake fluid immediately with water.

## 12.1 Checking the free travel of the hand brake lever



### Warning

**Danger of accidents** The brake system fails in the event of overheating.

If there is no free travel on the hand brake lever, pressure builds up on the front brake circuit.

- Set the free travel on the hand brake lever in accordance with the specification.

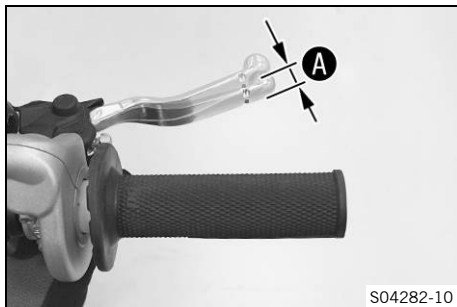

- Push the hand brake lever forward and check free travel **A**.

Free travel of hand brake lever	$\geq 3 \text{ mm}$ ( $\geq 0.12 \text{ in}$ )
---------------------------------	--

- » If the free travel does not match the specification:
  - Adjust the free travel of the handbrake lever. (📖 p. 72)

## 12.2 Adjusting the free travel of the handbrake lever

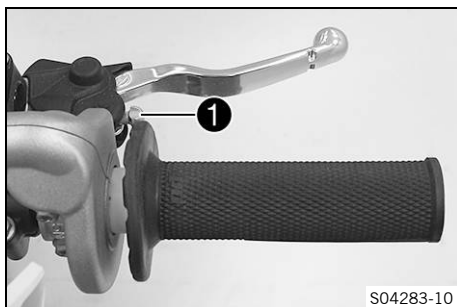

- Check the free travel of the hand brake lever. (📖 p. 72)
- Adjust the free travel of the handbrake lever with adjustment screw **1**.

### Info

Turn the adjusting screw clockwise to reduce free travel. The pressure point moves away from the handlebar.

Turn the adjusting screw counterclockwise to increase free travel. The pressure point moves towards the handlebar.

The range of adjustment is limited.

Turn the adjusting screw by hand only, and do not apply any force.

Do not make any adjustments while riding.

## 12.3 Checking the brake discs



### Warning

**Danger of accidents** Worn-out brake discs reduce the braking effect.

- Make sure that worn-out brake discs are replaced immediately. (Your authorized KTM workshop will be glad to help.)

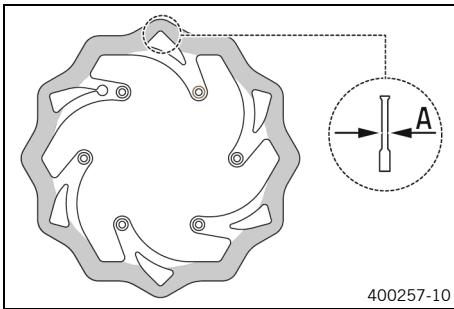

- Check the front and rear brake disc thickness at multiple points for the dimension **A**.

**i Info**  
Wear reduces the thickness of the brake disc around the contact surface of the brake linings.

Brake discs - wear limit	
front	3.5 mm (0.138 in)
rear	3.7 mm (0.146 in)

- » If the brake disc thickness is less than the specified value:
  - Change the front brake disc. 🛠️
  - Change the rear brake disc. 🛠️
- Check the front and rear brake discs for damage, cracking, and deformation.
  - » If the brake disc exhibits damage, cracking, or deformation:
    - Change the front brake disc. 🛠️
    - Change the rear brake disc. 🛠️



## 12.4 Checking the front brake fluid level



### Warning

**Danger of accidents** An insufficient brake fluid level will cause the brake system to fail.

If the brake fluid level drops below the specified marking or the specified value, the brake system is leaking or the brake linings are worn down.

- Check the brake system and ensure that nobody drives the vehicle before the problem is eliminated. (Your authorized KTM workshop will be glad to help.)



### Warning

**Danger of accidents** Old brake fluid reduces the braking effect.

- Make sure that brake fluid for the front and rear brake is changed in accordance with the service schedule. (Your authorized KTM workshop will be glad to help.)

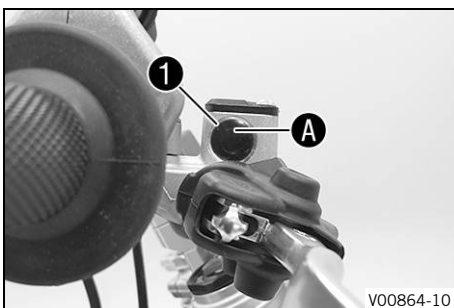

- Move the brake fluid reservoir mounted on the handlebar to a horizontal position.
- Check the brake fluid level in level viewer **1**.
  - » If the brake fluid level has dropped below the marking **A**:
    - Add the front brake fluid. 🛠️ (📖 p. 74)



## 12.5 Adding the front brake fluid 🐦



### Warning

**Danger of accidents** An insufficient brake fluid level will cause the brake system to fail.

If the brake fluid level drops below the specified marking or the specified value, the brake system is leaking or the brake linings are worn down.

- Check the brake system and ensure that nobody drives the vehicle before the problem is eliminated. (Your authorized KTM workshop will be glad to help.)



### Warning

**Skin irritation** Brake fluid causes skin irritation.

- Keep brake fluid out of the reach of children.
- Wear suitable protective clothing and safety glasses.
- Do not allow brake fluid to come into contact with the skin, the eyes or clothing.
- Consult a doctor immediately if brake fluid has been swallowed.
- Rinse the affected area with plenty of water in the event of contact with the skin.
- Rinse eyes thoroughly with water immediately and consult a doctor if brake fluid comes into contact with the eyes.
- If brake fluid spills on to your clothing, change the clothing.



### Warning

**Danger of accidents** Old brake fluid reduces the braking effect.

- Make sure that brake fluid for the front and rear brake is changed in accordance with the service schedule. (Your authorized KTM workshop will be glad to help.)



### Note

**Environmental hazard** Hazardous substances cause environmental damage.

- Dispose of oils, grease, filters, fuel, cleaning agents, brake fluid, etc., correctly and in compliance with the applicable regulations.



### Info

Never use DOT 5 brake fluid. It is silicone-based and purple in color. Oil seals and brake lines are not designed for DOT 5 brake fluid.

Avoid contact between brake fluid and painted parts. Brake fluid attacks paint.

Only use clean brake fluid from a sealed container.

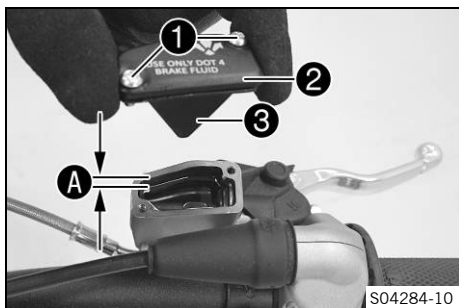

### Preparatory work

- Check the front brake linings. (📖 p. 75)

### Main work

- Move the brake fluid reservoir mounted on the handlebar to a horizontal position.
- Remove screws ①.
- Take off cover ② with membrane ③.
- Add brake fluid to level A.

### Guideline

Level A (brake fluid level below reservoir rim)	5 mm (0.2 in)
---	---------------

Brake fluid DOT 4 / DOT 5.1 (📖 p. 122)
--

- Position the cover with the membrane. Mount and tighten the screws.

**Info**

Immediately clean up any brake fluid that has overflowed or spilled with water.



## 12.6 Checking the front brake linings

**Warning**

**Danger of accidents** Worn-out brake linings reduce the braking effect.

- Ensure that worn-out brake linings are replaced immediately. (Your authorized KTM workshop will be glad to help.)

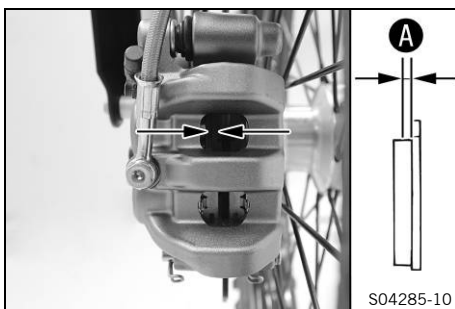

- Check the brake linings for minimum thickness **A**.

Minimum thickness <b>A</b>	$\geq 1 \text{ mm } (\geq 0.04 \text{ in})$
----------------------------	---

- » If the minimum thickness is less than specified:
  - Change the brake linings of the front brake. 🛠️ (p. 75)
- Check the brake linings for damage and cracking.
  - » If damage or cracking is visible:
    - Change the brake linings of the front brake. 🛠️ (p. 75)



## 12.7 Changing the brake linings of the front brake 🛠️

**Warning**

**Danger of accidents** Incorrect servicing will cause the brake system to fail.

- Ensure that service work and repairs are performed professionally. (Your authorized KTM workshop will be glad to help.)

**Warning**

**Skin irritation** Brake fluid causes skin irritation.

- Keep brake fluid out of the reach of children.
- Wear suitable protective clothing and safety glasses.
- Do not allow brake fluid to come into contact with the skin, the eyes or clothing.
- Consult a doctor immediately if brake fluid has been swallowed.
- Rinse the affected area with plenty of water in the event of contact with the skin.
- Rinse eyes thoroughly with water immediately and consult a doctor if brake fluid comes into contact with the eyes.
- If brake fluid spills on to your clothing, change the clothing.

**Warning**

**Danger of accidents** Old brake fluid reduces the braking effect.

- Make sure that brake fluid for the front and rear brake is changed in accordance with the service schedule. (Your authorized KTM workshop will be glad to help.)



## Warning

**Danger of accidents** Oil or grease on the brake discs reduces the braking effect.

- Always keep the brake discs free of oil and grease.
- Clean the brake discs with brake cleaner when necessary.



## Warning

**Danger of accidents** Brake linings which have not been approved alter the braking efficiency.

Not all brake linings are tested and approved for KTM motorcycles. The structure and friction coefficient of the brake linings, and thus their brake power, may vary greatly from that of original brake linings.

If brake linings are used that differ from the original equipment, compliance with the original homologation is not guaranteed. In this case, the vehicle no longer corresponds to its condition at delivery and the manufacturer warranty shall be void.

- Only use brake linings approved and recommended by KTM.



## Note

**Environmental hazard** Hazardous substances cause environmental damage.

- Dispose of oils, grease, filters, fuel, cleaning agents, brake fluid, etc., correctly and in compliance with the applicable regulations.



## Info

Never use DOT 5 brake fluid. It is silicone-based and purple in color. Oil seals and brake lines are not designed for DOT 5 brake fluid.

Avoid contact between brake fluid and painted parts. Brake fluid attacks paint.

Only use clean brake fluid from a sealed container.

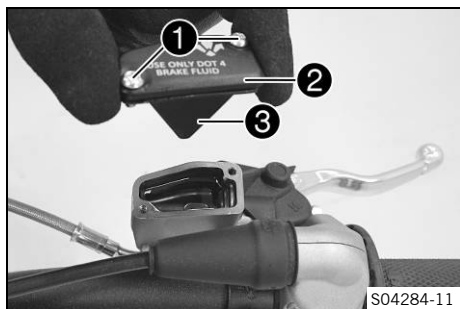

- Move the brake fluid reservoir mounted on the handlebar to a horizontal position.
- Remove screws ①.
- Take off cover ② with membrane ③.

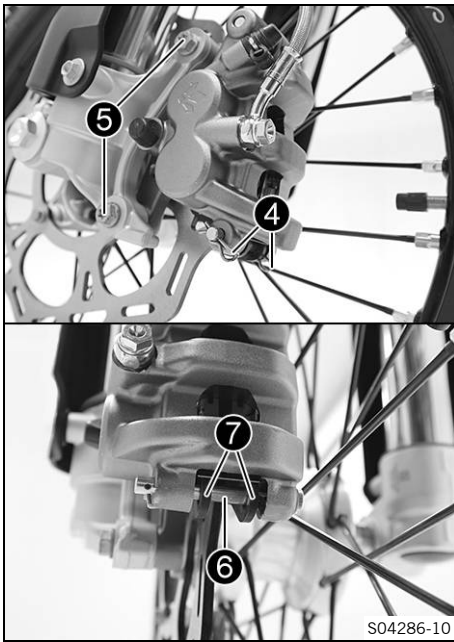

- Remove cotter pin ④.
- Remove screws ⑤.
- Press back the brake linings by slightly tilting the brake caliper laterally on the brake disc. Carefully pull the brake caliper backward from the brake disc.
- Press the brake piston back into the basic position and ensure that brake fluid does not flow out of the brake fluid reservoir, extracting some if necessary.
- Remove pin ⑥.
- Remove brake linings ⑦ and the retainer spring.
- Clean brake caliper.
- Position the retainer spring.
- Position the new brake linings.



**Info**

Always change the brake linings in pairs.

- Mount pin ⑥.



**Info**

To make it easier to mount the pin, push the brake linings against the retainer spring.  
Make sure the brake linings and retainer spring are seated correctly.

- Mount cotter pins ④.
- Position the brake caliper.
- Mount and tighten screws ⑤.

Guideline

Screw, front brake caliper	M8	25 Nm (18.4 lbf ft) <b>Loctite®243™</b>
----------------------------	----	--

- Correct the brake fluid up to level A.

Guideline

Level A (brake fluid level below reservoir rim)	5 mm (0.2 in)
---	---------------

Brake fluid DOT 4 / DOT 5.1 (📖 p. 122)

- Position cover ② with membrane ③.
- Mount and tighten screws ①.

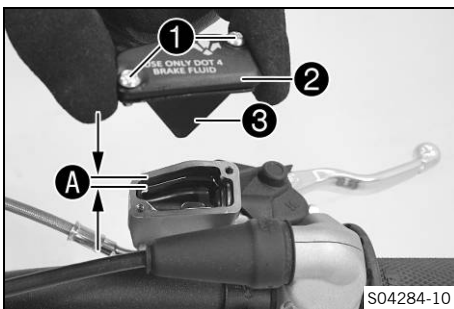

**Info**

Use water to immediately clean up any brake fluid that has overflowed or spilled.

## 12.8 Checking the free travel of foot brake lever



### Warning

**Danger of accidents** The brake system fails in the event of overheating.

If there is no free travel on the foot brake lever, pressure builds up in the brake system on the rear brake.

- Set the free travel on the foot brake lever in accordance with the specification.

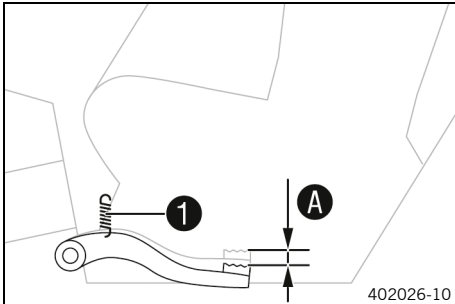

- Disconnect spring ①.
- Move the foot brake lever back and forth between the end stop and the contact to the foot brake cylinder piston and check free travel A.

### Guideline

Free travel at foot brake lever	3 ... 5 mm (0.12 ... 0.2 in)
---------------------------------	------------------------------

» If the free travel does not meet specifications:

- Adjust the basic position of the foot brake lever. (p. 78)
- Reconnect spring ①.

## 12.9 Adjusting the basic position of the foot brake lever



### Warning

**Danger of accidents** The brake system fails in the event of overheating.

If there is no free travel on the foot brake lever, pressure builds up in the brake system on the rear brake.

- Set the free travel on the foot brake lever in accordance with the specification.

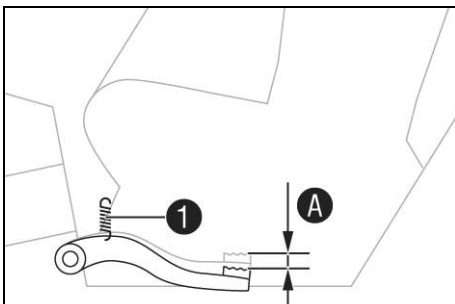

- Detach spring ①.
- Loosen nut ④ and, with push rod ⑤, turn it back until you have maximum free travel.
- To adjust the basic position of the foot brake lever to individual requirements, loosen nut ② and turn screw ③ accordingly.



### Info

The range of adjustment is limited.

- Turn push rod ⑤ accordingly until you have free travel A. If necessary, adjust the basic position of the foot brake lever.

### Guideline

Free travel at foot brake lever	3 ... 5 mm (0.12 ... 0.2 in)
---------------------------------	------------------------------

- Hold screw ③ and tighten nut ②.

### Guideline

Nut, foot brake lever stop	M8	20 Nm (14.8 lbf ft)
----------------------------	----	---------------------

- Hold push rod ⑤ and tighten nut ④.

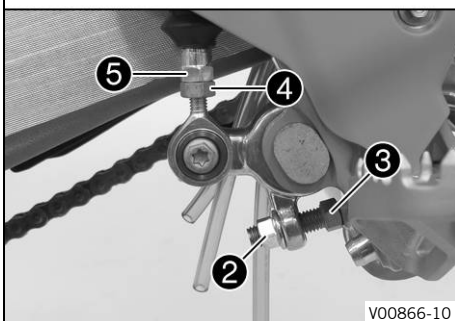



## Guideline

Remaining nuts, chassis	M6	10 Nm (7.4 lbf ft)
----------------------------	----	--------------------

- Attach spring ①.



## 12.10 Checking the rear brake fluid level



### Warning

**Danger of accidents** An insufficient brake fluid level will cause the brake system to fail.

If the brake fluid level drops below the specified marking or the specified value, the brake system is leaking or the brake linings are worn down.

- Check the brake system and do not continue riding until the problem is eliminated. (Your authorized KTM workshop will be glad to help.)



### Warning

**Danger of accidents** Old brake fluid reduces the braking effect.

- Make sure that brake fluid for the front and rear brake is changed in accordance with the service schedule. (Your authorized KTM workshop will be glad to help.)

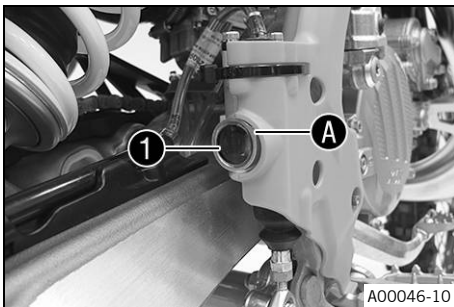

- Stand the vehicle upright.
- Check the brake fluid level in level viewer ①.



### Tip

Move the frame protector slightly to the side to make it easier to see the marking.

- » If the brake fluid has dropped below the marking A:
  - Add rear brake fluid. 📖 (p. 79)



## 12.11 Adding rear brake fluid 📖



### Warning

**Danger of accidents** An insufficient brake fluid level will cause the brake system to fail.

If the brake fluid level drops below the specified marking or the specified value, the brake system is leaking or the brake linings are worn down.

- Check the brake system and do not continue riding until the problem is eliminated. (Your authorized KTM workshop will be glad to help.)



### Warning

**Skin irritation** Brake fluid causes skin irritation.

- Keep brake fluid out of the reach of children.
- Wear suitable protective clothing and safety glasses.
- Do not allow brake fluid to come into contact with the skin, the eyes or clothing.
- Consult a doctor immediately if brake fluid has been swallowed.
- Rinse the affected area with plenty of water in the event of contact with the skin.
- Rinse eyes thoroughly with water immediately and consult a doctor if brake fluid comes into contact with the eyes.
- If brake fluid spills on to your clothing, change the clothing.



## Warning

**Danger of accidents** Old brake fluid reduces the braking effect.

- Make sure that brake fluid for the front and rear brake is changed in accordance with the service schedule. (Your authorized KTM workshop will be glad to help.)



## Note

**Environmental hazard** Hazardous substances cause environmental damage.

- Dispose of oils, grease, filters, fuel, cleaning agents, brake fluid, etc., correctly and in compliance with the applicable regulations.



## Info

Never use DOT 5 brake fluid. It is silicone-based and purple in color. Oil seals and brake lines are not designed for DOT 5 brake fluid.

Avoid contact between brake fluid and painted parts. Brake fluid attacks paint.

Only use clean brake fluid from a sealed container.

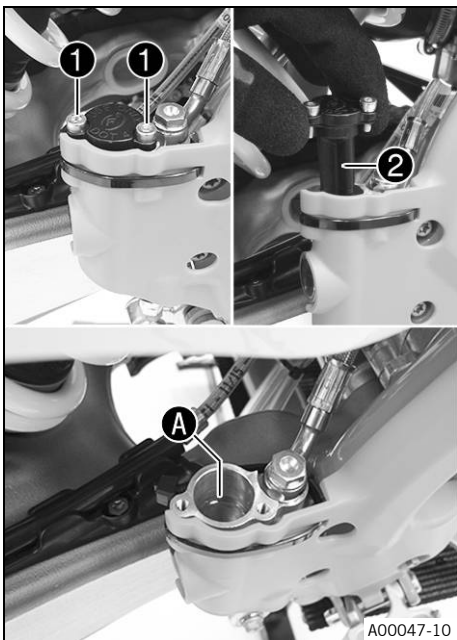

## Preparatory work

- Check the rear brake linings. (📖 p. 80)

## Main work

- Stand the vehicle upright.
- Remove screws **1**.
- Take off the cover with the washer and membrane **2**.
- Add brake fluid to level **A**.

Brake fluid DOT 4 / DOT 5.1 (📖 p. 122)

- Mount the cover with the washer and membrane.
- Mount and tighten the screws.



## Info

Clean up overflowed or spilled brake fluid immediately with water.

## 12.12 Checking the rear brake linings



## Warning

**Danger of accidents** Worn-out brake linings reduce the braking effect.

- Ensure that worn-out brake linings are replaced immediately. (Your authorized KTM workshop will be glad to help.)

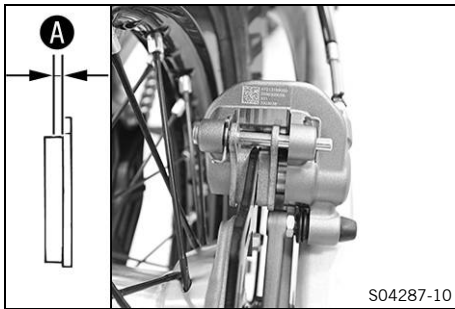

- Check the brake linings for minimum thickness **A**.

Minimum thickness <b>A</b>	$\geq 1 \text{ mm } (\geq 0.04 \text{ in})$
----------------------------	---

- » If the minimum thickness is less than specified:
  - Change the rear brake linings. 🛠️ (📖 p. 81)
- Check the brake linings for damage and cracking.
  - » If damage or cracking is visible:
    - Change the rear brake linings. 🛠️ (📖 p. 81)

### 12.13 Changing the rear brake linings 🛠️



#### Warning

**Danger of accidents** Incorrect servicing will cause the brake system to fail.

- Ensure that service work and repairs are performed professionally. (Your authorized KTM workshop will be glad to help.)



#### Warning

**Skin irritation** Brake fluid causes skin irritation.

- Keep brake fluid out of the reach of children.
- Wear suitable protective clothing and safety glasses.
- Do not allow brake fluid to come into contact with the skin, the eyes or clothing.
- Consult a doctor immediately if brake fluid has been swallowed.
- Rinse the affected area with plenty of water in the event of contact with the skin.
- Rinse eyes thoroughly with water immediately and consult a doctor if brake fluid comes into contact with the eyes.
- If brake fluid spills on to your clothing, change the clothing.



#### Warning

**Danger of accidents** Old brake fluid reduces the braking effect.

- Make sure that brake fluid for the front and rear brake is changed in accordance with the service schedule. (Your authorized KTM workshop will be glad to help.)



#### Warning

**Danger of accidents** Oil or grease on the brake discs reduces the braking effect.

- Always keep the brake discs free of oil and grease.
- Clean the brake discs with brake cleaner when necessary.



#### Warning

**Danger of accidents** Brake linings which have not been approved alter the braking efficiency.

Not all brake linings are tested and approved for KTM motorcycles. The structure and friction coefficient of the brake linings, and thus their brake power, may vary greatly from that of original brake linings.

If brake linings are used that differ from the original equipment, compliance with the original homologation is not guaranteed. In this case, the vehicle no longer corresponds to its condition at delivery and the manufacturer warranty shall be void.

- Only use brake linings approved and recommended by KTM.



#### Note

**Environmental hazard** Hazardous substances cause environmental damage.

- Dispose of oils, grease, filters, fuel, cleaning agents, brake fluid, etc., correctly and in compliance with the applicable regulations.

**i Info**

Never use DOT 5 brake fluid. It is silicone-based and purple in color. Oil seals and brake lines are not designed for DOT 5 brake fluid.  
 Avoid contact between brake fluid and painted parts. Brake fluid attacks paint.  
 Only use clean brake fluid from a sealed container.

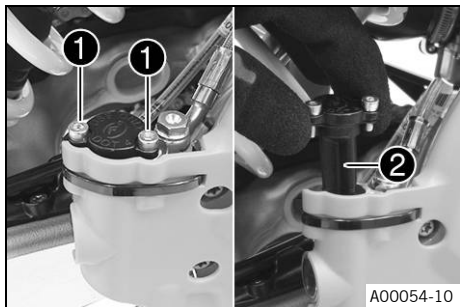

- Position the vehicle upright.
- Remove screws **1**.
- Take off the cover with the washer and membrane **2**.
- Press the brake piston back into the basic position and ensure that brake fluid does not flow out of the brake fluid reservoir, extracting some if necessary.

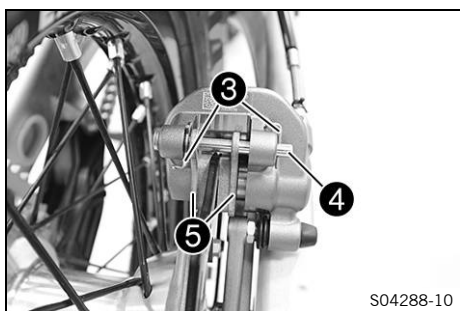

- Remove cotter pin **3**.
- Press back the brake linings by slightly tilting the brake caliper laterally on the brake disc.
- Remove pin **4**.
- Remove brake linings **5** and the retainer spring.
- Clean brake caliper.
- Position the retainer spring.
- Position the new brake linings.

**i Info**

Always change the brake linings in pairs.

- Mount pin **4**.

**i Info**

To make it easier to mount the pin, push the brake linings upwards against the retainer spring.  
 Make sure the brake linings and retainer spring are seated correctly.

- Mount cotter pins **3**.
- Check the brake discs. (📖 p. 72)
- Operate the foot brake lever repeatedly until the brake linings are in contact with the brake disc and there is a pressure point.

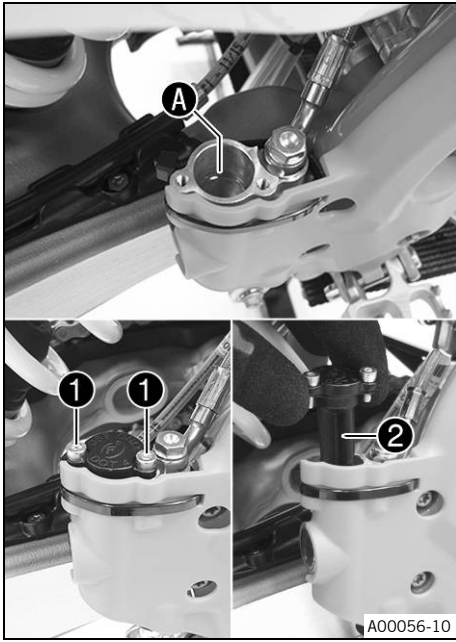

- Add brake fluid to level **A**.

Brake fluid DOT 4 / DOT 5.1 (📖 p. 122)

- Mount the cover with the washer and membrane **2**.
- Mount and tighten screws **1**.



**Info**

Use water to immediately clean up any brake fluid that has overflowed or spilled.

## 13.1 Removing the front wheel ↩

### Preparatory work

- Raise the motorcycle with a lift stand. (📖 p. 44)

### Main work

- Loosen screw ❶ by several rotations.
- Loosen screws ❷.
- Press on screw ❶ to push the wheel spindle out of the axle clamp.
- Remove screw ❶.

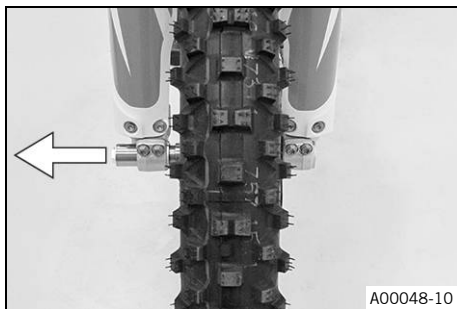
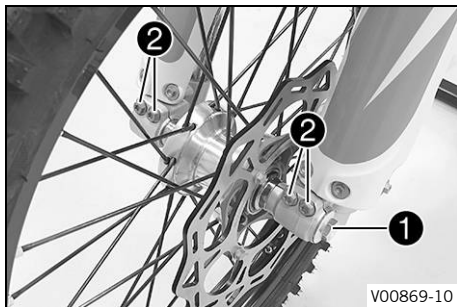

### Warning

**Danger of accidents** Damaged brake discs reduce the braking effect.

- Always lay the wheel down in such a way that the brake disc is not damaged.

- Hold the front wheel and remove the wheel spindle. Take the front wheel out of the fork.



### Info

Do not actuate the hand brake lever when the front wheel is removed.

- Remove spacers ❸.

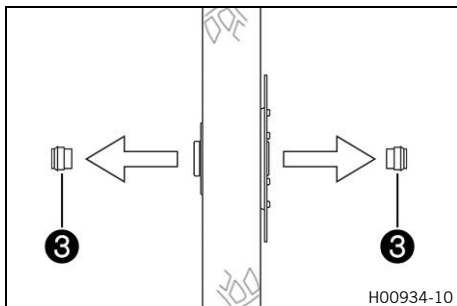

## 13.2 Installing the front wheel ↩



### Warning

**Danger of accidents** Oil or grease on the brake discs reduces the braking effect.

- Always keep the brake discs free of oil and grease.
- Clean the brake discs with brake cleaner when necessary.

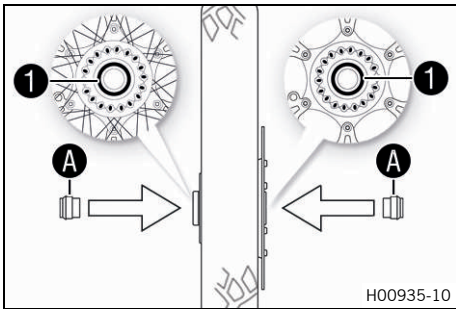

- Check the wheel bearing for damage and wear.
  - » If the wheel bearing is damaged or worn:
    - Change front wheel bearing. 🛠️
- Clean and grease shaft seal rings 1 and contact surfaces A of the spacers.

Long-life grease (📖 p. 124)
-----------------------------

- Insert the spacers.

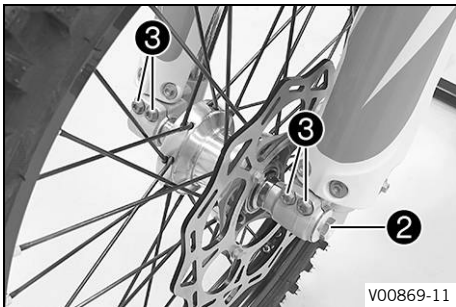

- Clean and grease the wheel spindle.
  - Long-life grease (📖 p. 124)
- Position the front wheel.
  - ✓ The brake linings are correctly positioned.
- Insert the wheel spindle.
- Mount and tighten screw 2.

Guideline

Screw, front wheel spindle	M20x1.5	35 Nm (25.8 lbf ft)
----------------------------	---------	---------------------

- Operate the hand brake lever several times until the brake linings are seated correctly against the brake disc.
- Remove the motorcycle from the lift stand. (📖 p. 44)
- Operate the front brake and compress the fork a few times firmly.
  - ✓ The fork legs straighten.
- Tighten screws 3.

Guideline

Screw, fork stub	M8	15 Nm (11.1 lbf ft)
------------------	----	---------------------

### 13.3 Removing the rear wheel 🛠️

**Preparatory work**

- Raise the motorcycle with a lift stand. (📖 p. 44)

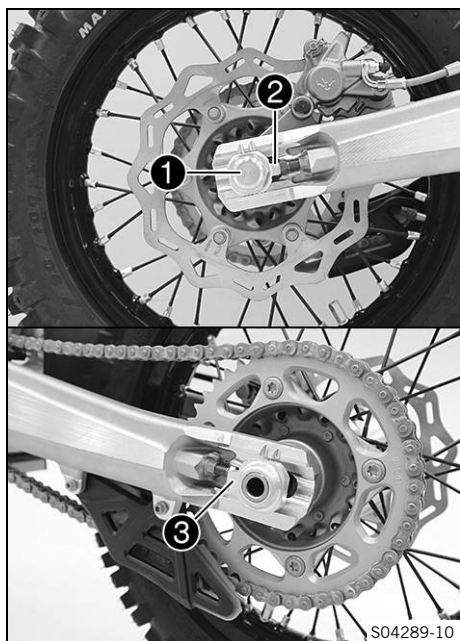

### Main work

- Remove nut ①.
- Take off chain adjuster ②. Pull out wheel spindle ③ far enough to allow the rear wheel to be pushed forward.
- Push the rear wheel forward as far as possible. Remove the chain from the rear sprocket.

**Info**  
Cover the components to protect them against damage.

**Warning**  
**Danger of accidents** Damaged brake discs reduce the braking effect.  
- Always lay the wheel down in such a way that the brake disc is not damaged.

- Hold the rear wheel and remove the wheel spindle. Take the rear wheel out of the link fork.

**Info**  
Do not operate the foot brake lever when the rear wheel is removed.

- Remove spacers ④.

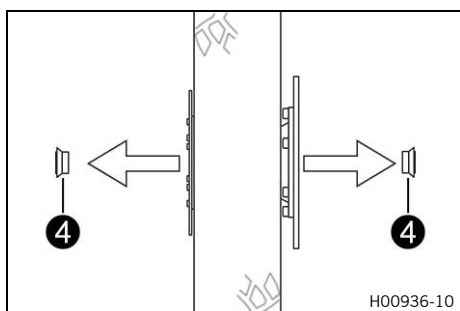

## 13.4 Installing the rear wheel

**Warning**  
**Danger of accidents** Oil or grease on the brake discs reduces the braking effect.  
- Always keep the brake discs free of oil and grease.  
- Clean the brake discs with brake cleaner when necessary.

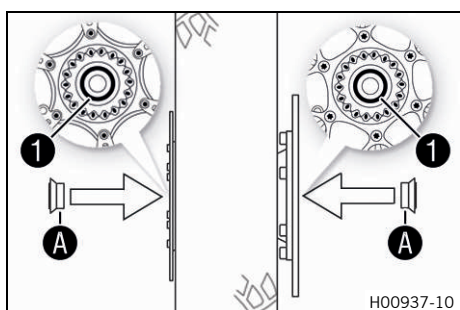

### Main work

- Check the wheel bearing for damage and wear.
  - » If the wheel bearing is damaged or worn:
    - Change the rear wheel bearing.
- Clean and grease shaft seal rings ① and contact surfaces A of the spacers.
 

Long-life grease (🛠️ p. 124)
- Insert the spacers.



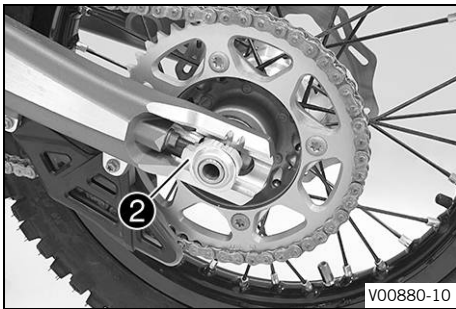

- Clean and grease the wheel spindle.

Long-life grease (📖 p. 124)

- Position rear wheel and mount the chain.
  - ✓ The brake linings are correctly positioned.
- Insert wheel spindle ②.

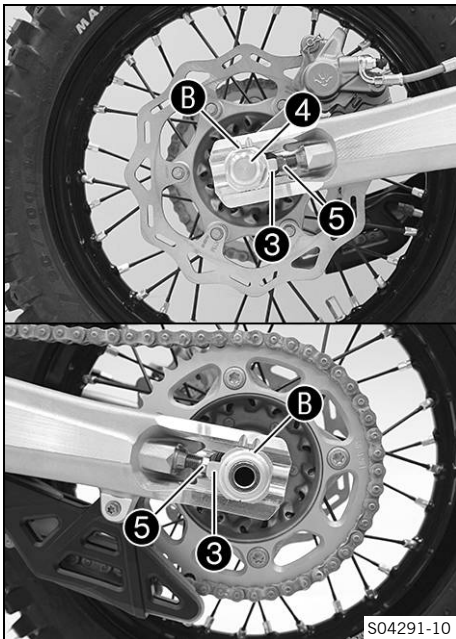

- Position chain adjuster ③. Mount nut ④, but do not tighten it yet.
- Make sure that chain adjusters ③ are fitted correctly on adjusting screws ⑤.
- Make sure that the markings on the left and right chain adjusters ③ are in the same position relative to reference marks B. The rear wheel is then correctly aligned.

**i Info**

The wide adjustment range of the chain adjusters enables different secondary ratios with the same chain length.

Chain adjusters ③ can be turned by 180°.

- Check the chain tension. (📖 p. 63)
- Tighten nut ④.

Guideline

Nut, rear wheel spindle	M20x1.5	80 Nm (59 lbf ft)
-------------------------	---------	-------------------

- Operate the foot brake lever repeatedly until the brake linings are in contact with the brake disc and there is a pressure point.

**Finishing work**

- Remove the motorcycle from the lift stand. (📖 p. 44)



## 13.5 Checking the tire condition

**i Info**

Only mount tires approved and/or recommended by KTM.

Other tires could have a negative effect on handling characteristics.

The type, condition, and pressure of the tires all have a major impact on the handling characteristic of the motorcycle.

The tires mounted on the front and rear wheels must have a similar profile.

Worn tires have a negative effect on handling characteristics, especially on wet surfaces.

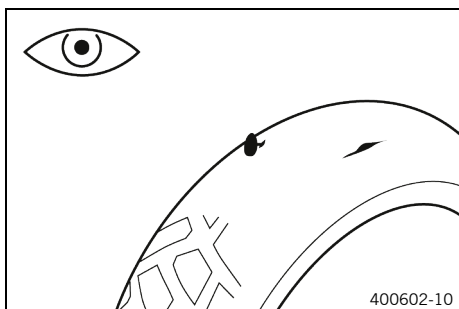

- Check the front and rear tires for cuts, embedded objects, and other damage.
  - » If the tires have cuts, run-in objects, or other damage:
    - Change the tires. 🛠️

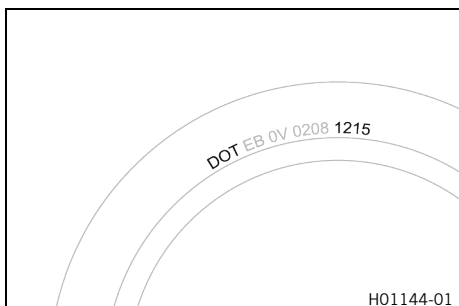

- Check the tire age.

**i Info**  
 The tire date of manufacture is usually contained in the tire label and is indicated by the last four digits of the **DOT** number. The first two digits indicate the week of manufacture and the last two digits the year of manufacture.  
 KTM recommends that the tires be changed after 5 years at the latest, regardless of the actual state of wear.

- » If the tires are more than five years old:
  - Change the tires. 🛠️

## 13.6 Checking tire pressure

**i Info**  
 Low tire pressure leads to abnormal wear and overheating of the tire. Correct tire pressure ensures optimal riding comfort and maximum tire service life.

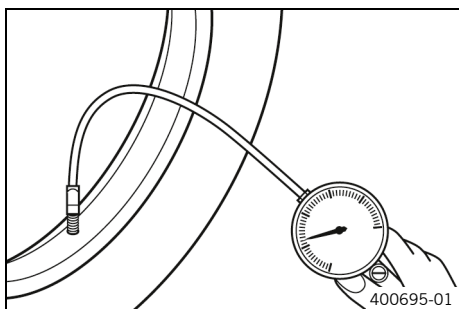

- Remove protection cap.
- Check tire pressure when the tires are cold.

Offroad tire pressure	
front	1.0 bar (15 psi)
rear	1.0 bar (15 psi)

- » If the tire pressure does not meet specifications:
  - Correct tire pressure.
- Mount the protection cap.

## 13.7 Checking spoke tension

**⚠ Warning**  
**Danger of accidents** Incorrectly tensioned spokes impair the handling characteristic and result in secondary damage.

The spokes break due to being overloaded if they are too tightly tensioned. If the tension in the spokes is too low, then lateral and radial run-out will form in the wheel. Other spokes will become looser as a result.

- Check spoke tension regularly, and in particular on a new vehicle. (Your authorized KTM workshop will be glad to help.)

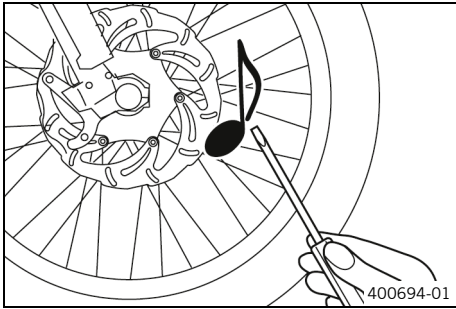

- Strike each spoke briefly using a screwdriver blade.



**Info**

The frequency of the sound depends on the spoke length and spoke diameter.  
If you hear different tone frequencies from different spokes of equal length and diameter, this is an indication of different spoke tensions.

You should hear a high note.

- » If the spoke tension differs:
  - Correct the spoke tension. 🛠️
- Check the spoke torque.

Guideline

Spoke nipple	M4.5	5 Nm (3.7 lbf ft)
--------------	------	-------------------

Torque wrench kit (58429094000)



## 14.1 Cooling system

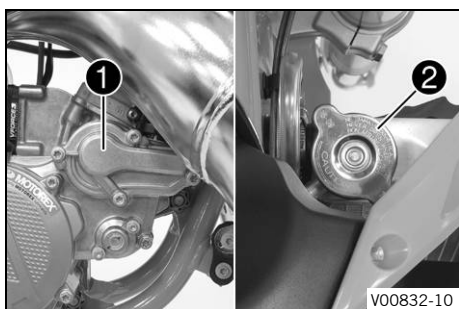

Water pump **1** in the engine circulates the coolant. The pressure resulting from the warming of the cooling system is regulated by a valve in radiator cap **2**. This ensures that operating the vehicle at the specified coolant temperature will not result in a risk of malfunctions.

120 °C (248 °F)
-----------------

Cooling is effected by the air stream. The lower the speed, the less the cooling effect. Dirty cooling fins also reduce the cooling effect.

## 14.2 Radiator cover

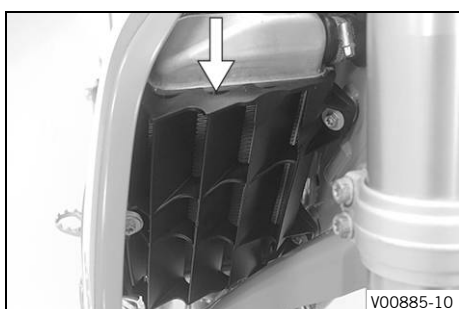

The radiator covers are mounted in front of the radiator between the radiator shield and radiator.

**i Info**  
Do not use radiator covers in difficult operating conditions.

The radiator cover keeps the coolant temperature in the correct range.

Optimal coolant temperature	60 ... 70 °C (140 ... 158 °F)
-----------------------------	-------------------------------

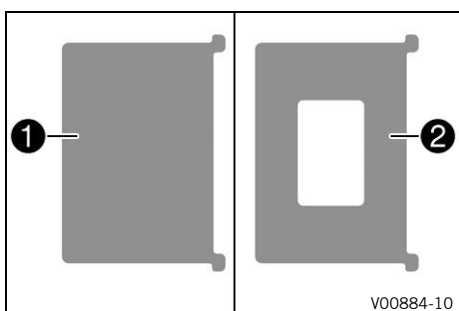

The radiator covers are installed in front of the radiator, depending on the ambient temperature.

Full radiator cover right side <b>1</b> and half radiator cover left side <b>2</b>	< 0 °C (< 32 °F)
--	------------------

Full radiator cover right side <b>1</b>	0 ... 10 °C (32 ... 50 °F)
---	----------------------------

Half radiator cover right side <b>2</b>	10 ... 20 °C (50 ... 68 °F)
---	-----------------------------

No radiator cover	> 20 °C (> 68 °F)
-------------------	-------------------

## 14.3 Installing the radiator cover

**i Info**  
Only remove left radiator shield if both radiator covers are mounted.

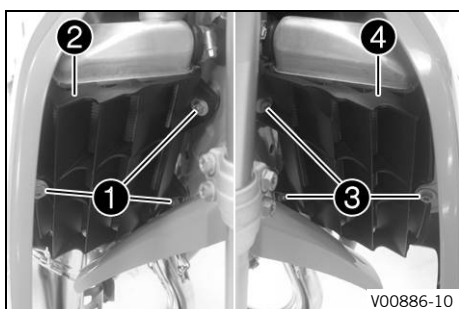

- Remove screws **1**.
- Remove right radiator shield **2**.
- Remove screws **3**.
- Remove left radiator shield **4**.

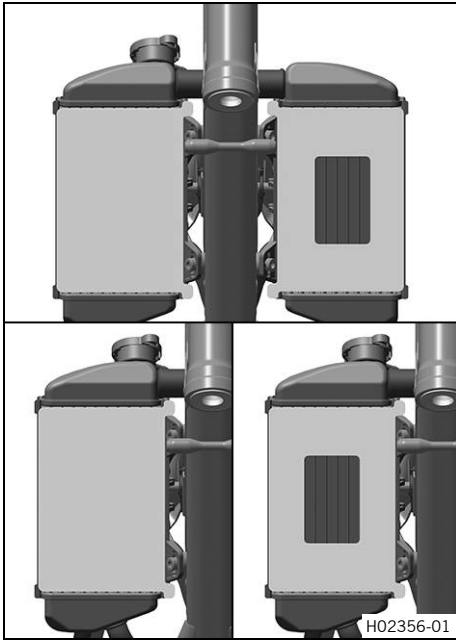

- Position the corresponding radiator cover (📖 p. 90).
- ✓ The holding lugs point toward the frame.

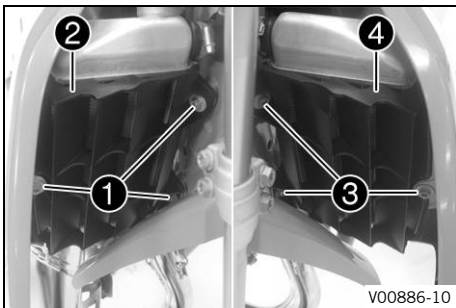

- Position left radiator shield ④.
- Mount and tighten screws ③.

Guideline

Remaining screws, chassis	M6	10 Nm (7.4 lbf ft)
---------------------------	----	--------------------

- Position right radiator shield ②.
- Mount and tighten screws ①.

Guideline

Remaining screws, chassis	M6	10 Nm (7.4 lbf ft)
---------------------------	----	--------------------

## 14.4 Removing the radiator cover

**i** Info

Only remove left radiator shield if both radiator covers are mounted.

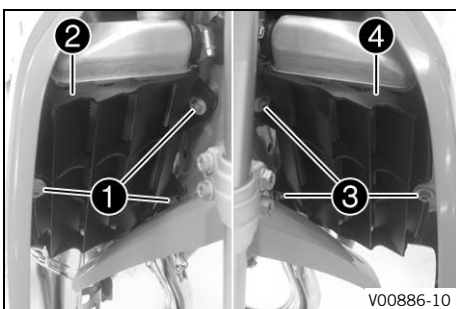

- Remove screws ①.
- Remove right radiator shield ②.
- Remove screws ③.
- Remove left radiator shield ④.
- Remove corresponding radiator cover.
- Position right radiator shield ②.
- Mount and tighten screws ①.

Guideline

Remaining screws, chassis	M6	10 Nm (7.4 lbf ft)
---------------------------	----	--------------------

- Position left radiator shield ④.
- Mount and tighten screws ③.

## Guideline

Remaining screws, chassis	M6	10 Nm (7.4 lbf ft)
---------------------------	----	--------------------

## 14.5 Checking the antifreeze and coolant level



### Warning

**Danger of scalding** During motorcycle operation, the coolant gets very hot and is under pressure.

- Do not open the radiator, the radiator hoses or other cooling system components if the engine or the cooling system are at operating temperature.
- Allow the cooling system and the engine to cool down before you open the radiator, the radiator hoses or other components of the cooling system.
- In the event of scalding, rinse the area affected immediately with lukewarm water.



### Warning

**Danger of poisoning** Coolant is toxic and a health hazard.

- Keep coolant out of the reach of children.
- Do not allow coolant to come into contact with the skin, the eyes and clothing.
- Consult a doctor immediately if coolant is swallowed.
- Rinse the affected area immediately with plenty of water in the event of contact with the skin.
- Rinse eyes thoroughly with water and consult a doctor immediately if coolant gets into the eyes.
- Change clothing if coolant spills onto your clothing.

### Condition

The engine is cold.

- Stand the motorcycle upright on a horizontal surface.
- Remove the radiator cap.
- Check the antifreeze in the coolant.

-25 ... -45 °C (-13 ... -49 °F)
---------------------------------

- » If the antifreeze in the coolant does not match the specified value:
  - Correct the antifreeze in the coolant.
- Check the coolant level in the radiator.

Coolant level <b>A</b> above the radiator fins	10 mm (0.39 in)
--	-----------------

- » If the coolant level does not match the specified value:
  - Correct the coolant level.

Coolant (📖 p. 122)
--------------------

- Mount the radiator cap.

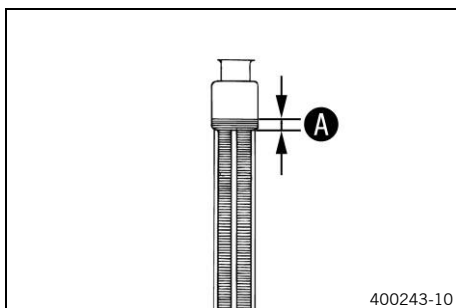

14.6 Checking the coolant level



**Warning**

**Danger of scalding** During motorcycle operation, the coolant gets very hot and is under pressure.

- Do not open the radiator, the radiator hoses or other cooling system components if the engine or the cooling system are at operating temperature.
- Allow the cooling system and the engine to cool down before you open the radiator, the radiator hoses or other components of the cooling system.
- In the event of scalding, rinse the area affected immediately with lukewarm water.



**Warning**

**Danger of poisoning** Coolant is toxic and a health hazard.

- Keep coolant out of the reach of children.
- Do not allow coolant to come into contact with the skin, the eyes and clothing.
- Consult a doctor immediately if coolant is swallowed.
- Rinse the affected area immediately with plenty of water in the event of contact with the skin.
- Rinse eyes thoroughly with water and consult a doctor immediately if coolant gets into the eyes.
- Change clothing if coolant spills onto your clothing.

**Condition**

The engine is cold.

- Stand the motorcycle upright on a horizontal surface.
- Remove the radiator cap.
- Check the coolant level in the radiator.

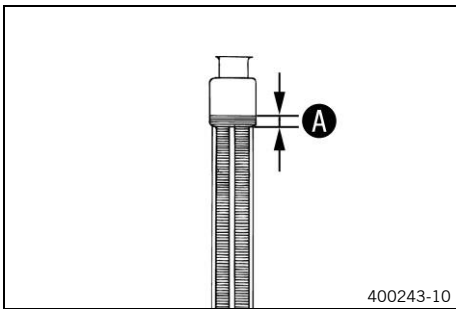

Coolant level <b>A</b> above the radiator fins	10 mm (0.39 in)
--	-----------------

- » If the coolant level does not match the specified value:
  - Correct the coolant level.

Coolant (📖 p. 122)
--------------------

- Mount the radiator cap.

14.7 Draining the coolant 🗑️



**Warning**

**Danger of scalding** During motorcycle operation, the coolant gets very hot and is under pressure.

- Do not open the radiator, the radiator hoses or other cooling system components if the engine or the cooling system are at operating temperature.
- Allow the cooling system and the engine to cool down before you open the radiator, the radiator hoses or other components of the cooling system.
- In the event of scalding, rinse the area affected immediately with lukewarm water.



## Warning

**Danger of poisoning** Coolant is toxic and a health hazard.

- Keep coolant out of the reach of children.
- Do not allow coolant to come into contact with the skin, the eyes and clothing.
- Consult a doctor immediately if coolant is swallowed.
- Rinse the affected area immediately with plenty of water in the event of contact with the skin.
- Rinse eyes thoroughly with water and consult a doctor immediately if coolant gets into the eyes.
- Change clothing if coolant spills onto your clothing.

## Condition

The engine is cold.

- Position the motorcycle upright.
- Place an appropriate container under the water pump cover.
- Remove screw **1**. Take off radiator cap **2**.
- Completely drain the coolant.
- Mount and tighten screw **1** with a new seal ring.

## Guideline

Coolant drain plug	M6	8 Nm (5.9 lbf ft)
--------------------	----	-------------------

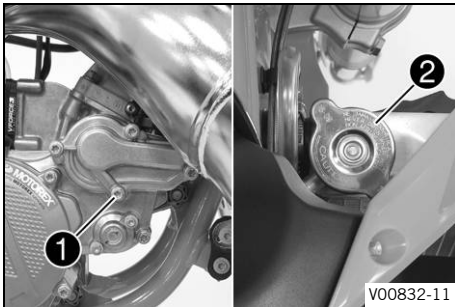

## 14.8 Refilling with coolant



## Warning

**Danger of poisoning** Coolant is toxic and a health hazard.

- Keep coolant out of the reach of children.
- Do not allow coolant to come into contact with the skin, the eyes and clothing.
- Consult a doctor immediately if coolant is swallowed.
- Rinse the affected area immediately with plenty of water in the event of contact with the skin.
- Rinse eyes thoroughly with water and consult a doctor immediately if coolant gets into the eyes.
- Change clothing if coolant spills onto your clothing.

## Main work

- Make sure that screw **1** is tightened.
- Position the motorcycle upright.
- Take off radiator cap **2**.
- Completely fill the radiator with coolant.

Coolant ( p. 122)
-------------------

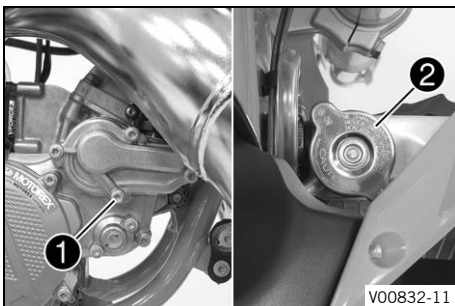



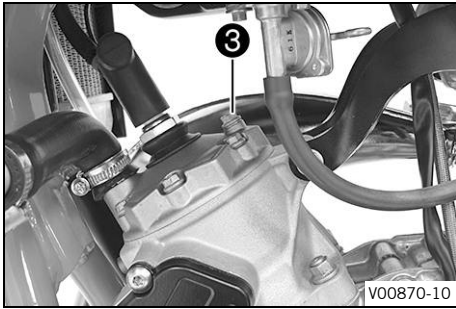

- Loosen screw ③ until coolant escapes without bubbles.
- Mount and tighten screw ③.

Guideline

Screw, radiator bleeding	M6	8 Nm (5.9 lbf ft)
--------------------------	----	-------------------

- Completely fill the radiator with coolant.

Coolant (📖 p. 122)
--------------------

- Mount radiator cap ②.

**⚠ Danger**  
**Danger of poisoning** Exhaust gases are toxic and inhaling them may result in unconsciousness and death.

- Always make sure there is sufficient ventilation when running the engine.
- Use effective exhaust extraction when starting or running the engine in an enclosed space.

- Allow the engine to warm up and cool down again.
- Check the coolant level. (📖 p. 93)

**Finishing work**

- Check the cooling system for leaks.



**14.9 Changing the coolant ↩**

**⚠ Warning**  
**Danger of scalding** During motorcycle operation, the coolant gets very hot and is under pressure.

- Do not open the radiator, the radiator hoses or other cooling system components if the engine or the cooling system are at operating temperature.
- Allow the cooling system and the engine to cool down before you open the radiator, the radiator hoses or other components of the cooling system.
- In the event of scalding, rinse the area affected immediately with lukewarm water.

**⚠ Warning**  
**Danger of poisoning** Coolant is toxic and a health hazard.

- Keep coolant out of the reach of children.
- Do not allow coolant to come into contact with the skin, the eyes and clothing.
- Consult a doctor immediately if coolant is swallowed.
- Rinse the affected area immediately with plenty of water in the event of contact with the skin.
- Rinse eyes thoroughly with water and consult a doctor immediately if coolant gets into the eyes.
- Change clothing if coolant spills onto your clothing.

**Condition**  
 The engine is cold.

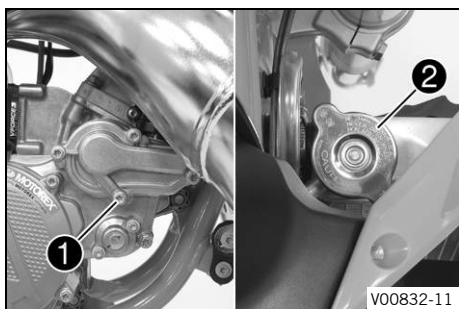

- Place an appropriate container under the water pump cover.
- Remove screw ①. Take off radiator cap ②.
- Completely drain the coolant.
- Mount and tighten screw ① with a new seal ring.

Guideline

Coolant drain plug	M6	8 Nm (5.9 lbf ft)
--------------------	----	-------------------

- Position the motorcycle upright.
- Completely fill the radiator with coolant.

Coolant (📖 p. 122)

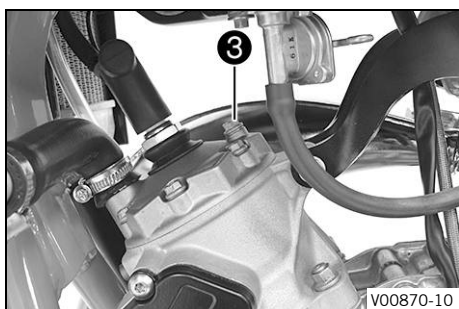

- Loosen screw ③ until coolant escapes without bubbles.
- Mount and tighten screw ③.

Guideline

Screw, radiator bleeding	M6	8 Nm (5.9 lbf ft)
--------------------------	----	-------------------

- Mount radiator cap ②.



### Danger

**Danger of poisoning** Exhaust gases are toxic and inhaling them may result in unconsciousness and death.

- Always make sure there is sufficient ventilation when running the engine.
- Use effective exhaust extraction when starting or running the engine in an enclosed space.

- Allow the engine to warm up and cool down again.
- Check the cooling system for leaks.
- Check the coolant level. (📖 p. 93)

## 15.1 Checking the play in the throttle cable

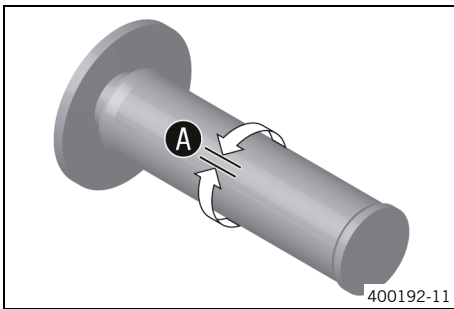

- Check the throttle grip for smooth operation.
- Move the handlebar to the straight-ahead position. Turn the throttle grip back and forth slightly and determine the play in throttle cable **A**.

Play in throttle cable	2 ... 3 mm (0.08 ... 0.12 in)
------------------------	-------------------------------

- » If the throttle cable play does not meet the specified value:
  - Adjust the play in the throttle cable. 🛠️ (p. 97)



### Danger

**Danger of poisoning** Exhaust gases are toxic and inhaling them may result in unconsciousness and death.

- Always make sure there is sufficient ventilation when running the engine.
- Use effective exhaust extraction when starting or running the engine in an enclosed space.

- Start the engine and let it run at idle speed. Move the handlebar to and fro over the entire steering range.

The idle speed must not change.

- » If the idle speed changes:
  - Adjust the play in the throttle cable. 🛠️ (p. 97)

## 15.2 Adjusting the play in the throttle cable 🛠️

### Preparatory work

- Remove the seat. (📖 p. 55)
- Turn tap handle of the fuel tap to the **OFF** position.
- Remove the fuel tank. 🛠️ (📖 p. 59)
- Check the throttle cable routing. (📖 p. 67)

### Main work

- Move the handlebar to the straight-ahead position.
- Push back sleeve **1**.
- Ensure that the throttle cable sleeve is pushed all the way into barrel adjuster **2**.
- Loosen nut **3**.

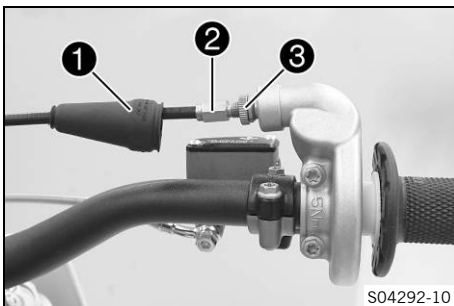

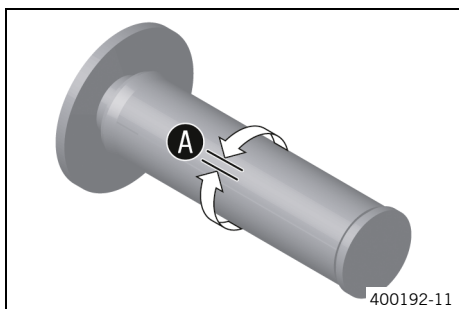

- Turn barrel adjuster **2** so that there is play **A** in the throttle cable at the throttle grip.

Guideline

Play in throttle cable	2 ... 3 mm (0.08 ... 0.12 in)
------------------------	-------------------------------

- Tighten nut **3**.
- Slide on sleeve **1**.

### Finishing work

- Install the fuel tank. (🔧 p. 61)
- Mount the seat. (🔧 p. 55)
- Check the play in the throttle cable. (🔧 p. 97)

## 15.3 Carburetor tuning

### Effects of carburetor tuning

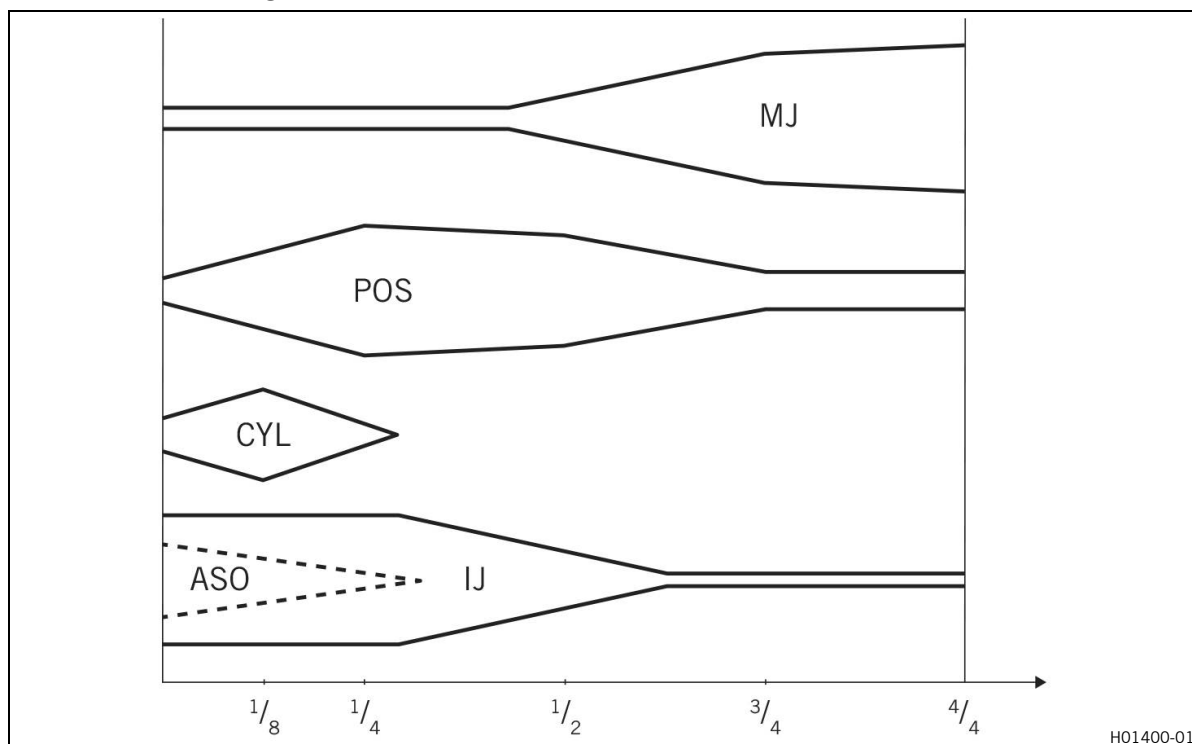

The different carburetor components must be tuned both to one another and for the use intended.

#### Main jet MJ

The main jet MJ has the greatest influence with the throttle slide open (full throttle).

If the insulator of a new spark plug is very light or white after a brief ride at full throttle, or if the engine knocks, a larger main jet needs to be used. If the insulator is dark brown or sooty, a smaller main jet needs to be used.

#### Needle position POS

The needle position has the greatest influence in the mid throttle slide range.

If the engine stutters when accelerating with a partially open throttle slide, the jet needle must be lowered. If the engine knocks when accelerating at the full power rpm range, the jet needle must be raised.

#### Cylindrical part of the needle CYL

The cylindrical part of the needle has the greatest influence when the throttle slide is almost closed.

## Idling jet IJ

The idling jet has the greatest influence in the low to mid throttle slide range.

If the engine stutters at idle speed or when accelerating with a partially open throttle slide, a smaller idling jet must be used. If the engine knocks in this power range, then a larger idling jet must be used.

## Idle air adjusting screw open ASO

The idle air adjusting screw has the greatest influence at idle speed.

## Influence of throttle slide adjustment

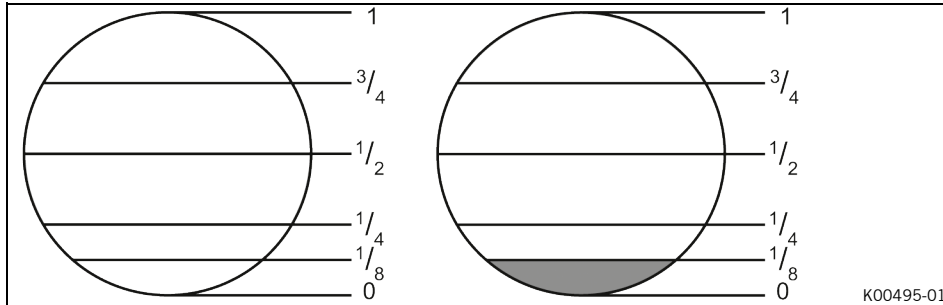

The idling jet has the greatest influence when the throttle slide is closed. The first cylindrical part of the needle and the clip position have only minimal influence.

When the throttle slide is 1/8 open, the first cylindrical part of the needle, the idling jet and the clip position have the greatest influence.

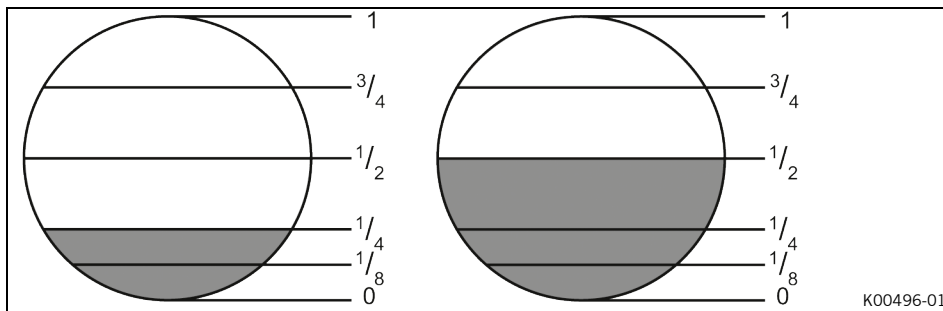

When the throttle slide is 1/4 open, the idling jet and the clip position have the greatest influence. The influence of the first cylindrical part of the needle is less.

When the throttle slide is 1/2 open, the position of the needle has the greatest influence. The influence of the main jet and the idling jet is only minimal.

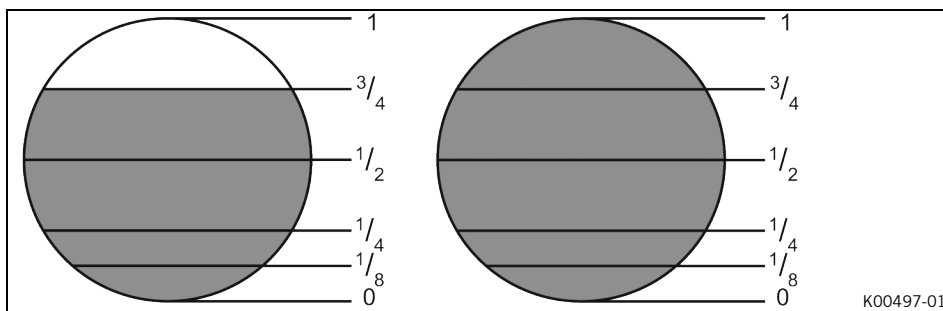

When the throttle slide is 3/4 open, the influence of the main jet is greatest. The clip position and the idling jet have only minimal influence.

When the throttle slide is fully open, the influence of the main jet is greatest. The clip position and the idling jet have only minimal influence.

## Needle overview

The jet needles available are shown in the following table.

	1	2	3
A	NRJ A	NRK A	2.405 mm
B	NRJ B	NRK B	2.415 mm
C	NRJ C	NRK C	2.425 mm
D	NRJ D	NRK D	2.435 mm
E	NRJ E	NRK E	2.445 mm

402797-01

Column **2** corresponds to a needle in the standard position.

Column **1** corresponds to a needle which is half a clip leaner.

Column **3** specifies the diameter of the first cylindrical part of the needle. The smaller the diameter of the first cylindrical part of the needle, the richer the mixture. The larger the diameter of the first cylindrical part of the needle, the leaner the mixture. The first cylindrical part of the needle has the greatest influence in the lowest load range.

### **i** Info

The top right jet needle **A2** corresponds to the richest setting of the carburetor, and the bottom left jet needle **E1** corresponds to the leanest. The optimal carburetor tuning is shown under the respective model.

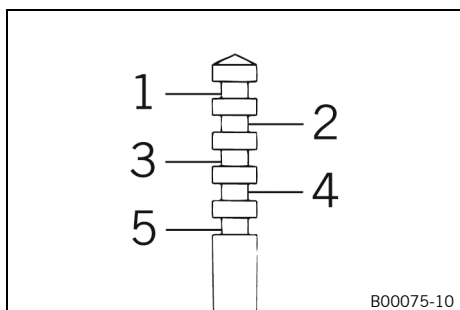

### Clip position

1 ... 5	Clip position from above
---------	--------------------------

The five possible clip positions are shown here.

The carburetor tuning depends on the defined ambient and operating conditions.

## 15.4 Carburetor – idle setting

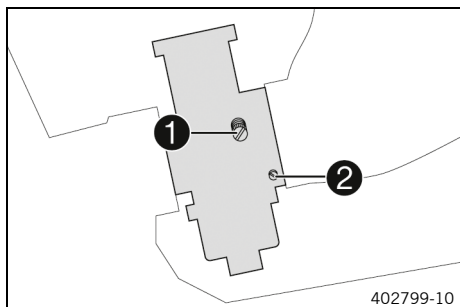

The idle setting of the carburetor has a big influence on the starting behavior, stable idle speed, and the response to throttle opening. This means that an engine with a correctly set idle speed will be easier to start than one with an incorrectly set idle speed.

### **i** Info

The carburetor and its components are subject to increased wear caused by engine vibration. Wear can result in malfunctioning.

The factory setting for the carburetor is set for the following values.

Height above sea level	301 ... 750 m (988 ... 2,461 ft)
Ambient temperature	16 ... 24 °C (61 ... 75 °F)
Super unleaded (98 octane) mixed with 2-stroke engine oil (1:40) (📖 p. 123)	

The idle speed is adjusted with adjusting screw **1**.

The idle mixture is adjusted using the idle air adjusting screw **2**.

## 15.5 Carburetor – adjusting the idle speed 🐦

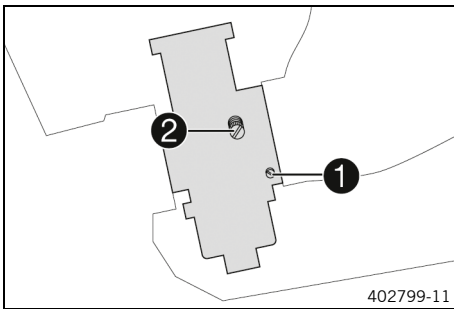

- Screw in idle air adjusting screw ① all the way and turn it to the specified basic setting.

Guideline

Idle air adjusting screw	
open	2 turns

- Run the engine until warm.

Guideline

Warming-up phase	≥ 5 min
------------------	---------



### Danger

**Danger of poisoning** Exhaust gases are toxic and inhaling them may result in unconsciousness and death.

- Always make sure there is sufficient ventilation when running the engine.
- Use effective exhaust extraction when starting or running the engine in an enclosed space.

- Adjust the idle speed with adjusting screw ②.

Guideline

Choke function deactivated – The choke lever is pushed in to the stop. (📖 p. 16)	
Idle speed	1,400 ... 1,500 rpm

- Turn idle air adjusting screw ① slowly in a clockwise direction until the idle speed begins to fall.
- Note the position and turn the idle air adjusting screw slowly counterclockwise until the idle speed again begins to fall.
- Adjust to the point between these two positions with the highest idle speed.



### Info

If there is a big engine speed rise, reduce the idle speed to a normal level and repeat the above steps. If the procedure described here does not lead to satisfactory results, the cause may be a wrongly dimensioned idling jet.

If you can turn the idle air adjusting screw to the end without any change of engine speed, mount a smaller idling jet.

After changing the idling jet, start from the beginning with the adjusting steps.

Following extreme air temperature or altitude changes, adjust the idle speed again.

## 15.6 Emptying the carburetor float chamber ↩



### Danger

**Fire hazard** Fuel is highly flammable.

The fuel in the fuel tank expands when warm and can escape if overfilled.

- Do not fuel the vehicle in the vicinity of open flames or lit cigarettes.
- Switch off the engine for refueling.
- Make sure that no fuel is spilled; particularly not on hot parts of the vehicle.
- If any fuel is spilled, wipe it off immediately.
- Observe the specifications for refueling.



### Warning

**Danger of poisoning** Fuel is poisonous and a health hazard.

- Avoid skin, eye and clothing contact with fuel.
- Immediately consult a doctor if you swallow fuel.
- Do not inhale fuel vapors.
- In case of skin contact, rinse the affected area with plenty of water.
- Rinse the eyes thoroughly with water, and consult a doctor in case of fuel contact with the eyes.
- Change your clothing in case of fuel spills on them.
- Keep fuels correctly in a suitable canister, and out of the reach of children.



### Note

**Environmental hazard** Improper handling of fuel is a danger to the environment.

- Do not allow fuel to enter the groundwater, the soil, or the sewage system.



### Info

Carry out this work with a cold engine.  
Water in the float chamber results in malfunctioning.

### Preparatory work

- Turn tap handle of the fuel tap to the **OFF** position.  
✓ No more fuel flows from the fuel tank to the carburetor.

### Main work

- Place a cloth beneath the carburetor to soak up emerging fuel.
- Remove plug ❶.
- Completely drain the fuel.
- Mount and tighten screw plug ❶.

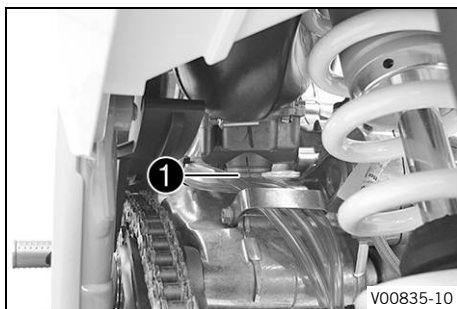



**15.7 Plug-in connector of ignition timing map adjustment**

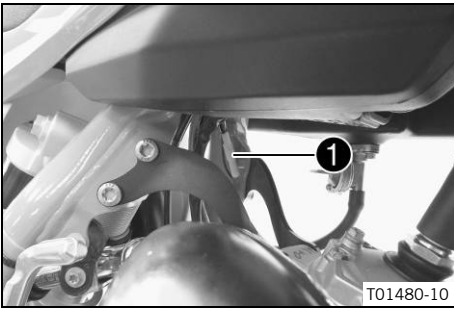

Plug-in connector **1** of the ignition timing map adjustment is located on the frame under the fuel tank.

**Possible states**

- Soft – The plug-in connector of the ignition timing map adjustment is disconnected to achieve better rideability.
- Performance – The plug-in connector of the ignition timing map adjustment is joined to achieve higher performance.

**15.8 Changing the ignition timing map**

**Switching the ignition timing map from Performance to Soft**

- Disconnect plug-in connector **1** of the ignition timing map adjustment. (Figure T01480-10 p. 103)
  - ✓ Soft – Better rideability

**Switching the ignition timing map from Soft to Performance**

- Join plug-in connector **1** of the ignition timing map adjustment. (Figure T01480-10 p. 103)
  - ✓ Performance – Higher performance

**15.9 Checking the basic position of the shift lever**

**i Info**

When driving, the shift lever must not touch the rider's boot when in the basic position. When the shift lever keeps touching the boot, the transmission will be subject to an excessive load.

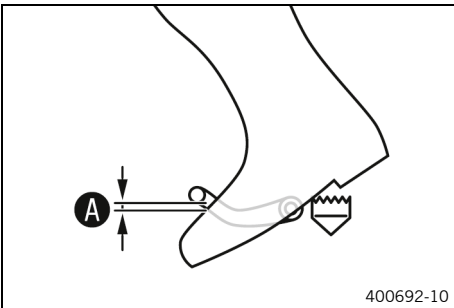

- Sit on the vehicle in the riding position and determine distance **A** between the upper edge of your boot and the shift lever.

Distance between shift lever and upper edge of boot	10 ... 20 mm (0.39 ... 0.79 in)
---	---------------------------------

- » If the distance does not meet specifications:
  - Adjust the basic position of the shift lever. ( p. 103)

**15.10 Adjusting the basic position of the shift lever**

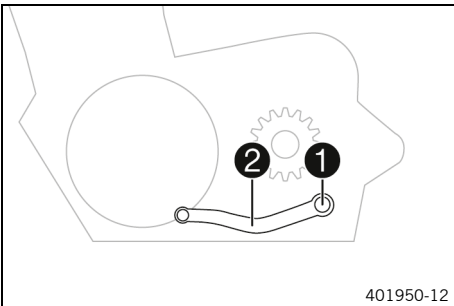

- Remove screw **1** with the washers and take off shift lever **2**.

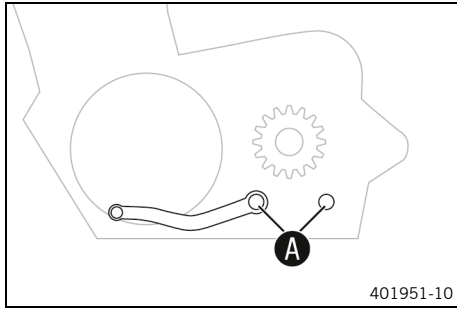

- Clean gear teeth **A** of the shift lever and shift shaft.
- Mount the shift lever on the shift shaft in the required position and engage gearing.



**Info**

The range of adjustment is limited.  
The shift lever must not come into contact with any other vehicle components during the shift procedure.

- Mount and tighten screw **1** with washers.

Guideline

Screw, shift lever	M6	14 Nm (10.3 lbf ft) <b>Loctite®243™</b>
--------------------	----	--

## 16.1 Checking the gear oil level

### Condition

The engine is cold.

### Preparatory work

- Stand the motorcycle upright on a horizontal surface.

### Main work

- Remove screw ❶ with the seal ring.
- Check the gear oil level.

Gear oil must not run out of the hole.
--

The gear oil level is at the lower edge of the hole.
--

- » If the gear oil level is below the hole:
  - Add the gear oil. 🛠️ (p. 106)
- » If gear oil runs out:
  - Correct the gear oil level.

- Mount and tighten screw ❶ with the seal ring.

### Guideline

Screw, gear oil level monitoring	M6	8 Nm (5.9 lbf ft)
----------------------------------	----	-------------------

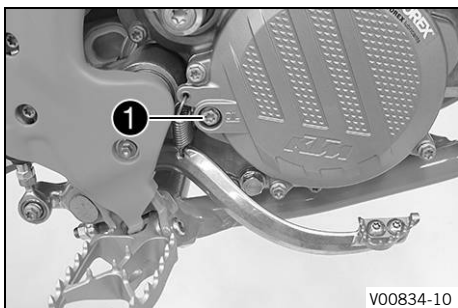

V00834-10

## 16.2 Changing the gear oil 🛠️



### Warning

**Danger of scalding** Engine and gear oil get very hot when the motorcycle is ridden.

- Wear suitable protective clothing and safety gloves.
- In the event of scalding, rinse the area affected immediately with lukewarm water.



### Note

**Environmental hazard** Hazardous substances cause environmental damage.

- Dispose of oils, grease, filters, fuel, cleaning agents, brake fluid, etc., correctly and in compliance with the applicable regulations.



### Info

Drain the gear oil while the engine is at operating temperature.

### Preparatory work

- Stand the motorcycle upright on a horizontal surface.
- Position an appropriate container under the engine.

### Main work

- Remove oil drain plug ❶ with the magnet.
- Let the gear oil drain fully.
- Thoroughly clean the oil drain plug with magnet.
- Clean the sealing surface on the engine.
- Mount and tighten oil drain plug ❶ with the magnet and a new seal ring.

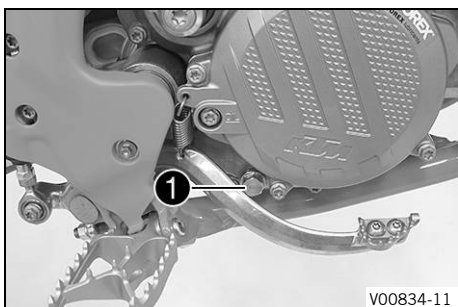

V00834-11

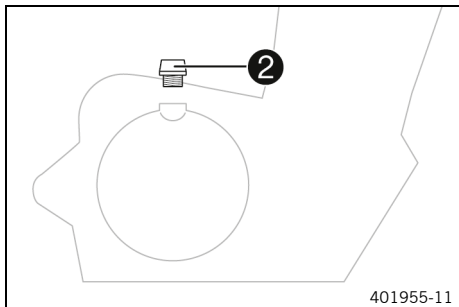

### Guideline

Oil drain plug with magnet	M12	20 Nm (14.8 lbf ft)
----------------------------	-----	---------------------

- Remove filler plug ② with the O-ring, and fill up with gear oil.

Gear oil	0.50 l (0.53 qt.)	Engine oil (15W/50) (📖 p. 122)
----------	----------------------	--------------------------------------

- Mount and tighten filler plug ② with the O-ring.



### Danger

**Danger of poisoning** Exhaust gases are toxic and inhaling them may result in unconsciousness and death.

- Always make sure there is sufficient ventilation when running the engine.
- Use effective exhaust extraction when starting or running the engine in an enclosed space.

- Start the engine and check for leaks.

### Finishing work

- Check the gear oil level. (📖 p. 105)

## 16.3 Adding the gear oil ↩



### Info

Too little gear oil or poor-quality gear oil results in premature wear to the transmission.

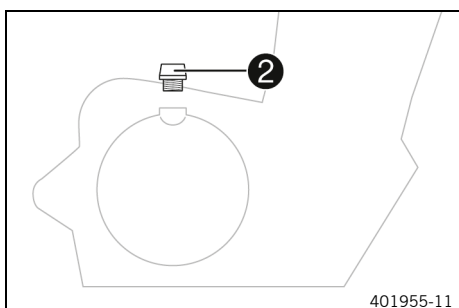
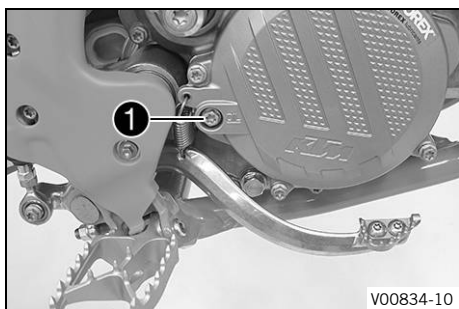

### Preparatory work

- Stand the motorcycle upright on a horizontal surface.

### Main work

- Remove screw ① with the seal ring.

- Remove filler plug ② with the O-ring.
- Add gear oil up to the bottom edge of the hole of the gear oil level plug.

Engine oil (15W/50) (📖 p. 122)
--------------------------------

- Mount and tighten screw ① with the seal ring.

### Guideline

Screw, gear oil level monitoring	M6	8 Nm (5.9 lbf ft)
----------------------------------	----	-------------------

- Mount and tighten filler plug ② with the O-ring.

**Danger**

**Danger of poisoning** Exhaust gases are toxic and inhaling them may result in unconsciousness and death.

- Always make sure there is sufficient ventilation when running the engine.
- Use effective exhaust extraction when starting or running the engine in an enclosed space.

- Start the engine and check for leaks.

**Finishing work**

- Check the gear oil level. (📖 p. 105)



## 17.1 Cleaning the motorcycle

### Note

**Material damage** Components become damaged or destroyed if a pressure cleaner is used incorrectly.

The high pressure forces water into the electrical components, connectors, throttle cables, and bearings, etc. Pressure which is too high causes malfunctions and destroys components.

- Do not direct the water jet directly on to electrical components, connectors, throttle cables or bearings.
- Maintain a minimum distance between the nozzle of the pressure cleaner and the component.

Minimum clearance

60 cm (23.6 in)



### Note

**Environmental hazard** Hazardous substances cause environmental damage.

- Dispose of oils, grease, filters, fuel, cleaning agents, brake fluid, etc., correctly and in compliance with the applicable regulations.



### Info

To maintain the value and appearance of the motorcycle over a long period, clean it regularly. Avoid direct sunshine when cleaning the motorcycle.

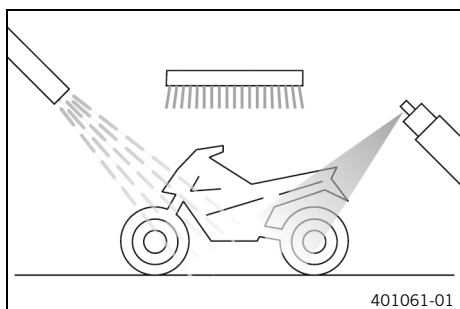

- Close off exhaust system to keep water from entering.
- Remove loose dirt first with a soft jet of water.
- Spray the heavily soiled parts with a normal commercial motorcycle cleaner and clean using a brush.

Motorcycle cleaner (📖 p. 124)



### Info

Use warm water containing normal motorcycle cleaner and a soft sponge.

Never apply motorcycle cleaner to a dry vehicle; always rinse the vehicle with water first.

- After rinsing the motorcycle with a gentle spray of water, allow it to dry thoroughly.
- Remove the closure of the exhaust system.
- Empty the carburetor float chamber. 📖 (p. 102)



### Warning

**Danger of accidents** Moisture and dirt impair the brake system.

- Explain to your child that he or she must brake carefully several times to dry out and remove dirt from the brake linings and the brake discs.

- After cleaning, let your child ride the vehicle a short distance until the engine warms up and the brakes have dried due to careful application of the brakes.



### Info

The heat produced causes water at inaccessible locations in the engine and on the brake system to evaporate.

- Push back the protection caps on the handlebar controls to allow water to evaporate.
- After the motorcycle has cooled down, lubricate all moving parts and pivot points.
- Clean the chain. (📖 p. 62)
- Treat bare metal (except for brake discs and the exhaust system) with a corrosion inhibitor.

Preserving materials for paints, metal and rubber  
(📖 p. 124)

- Treat all plastic parts and powder-coated parts with a mild cleaning and care product.

Special cleaner for glossy and matte paint finishes, metal and plastic surfaces (📖 p. 125)



## 18.1 Storage

**Warning**

**Danger of poisoning** Fuel is poisonous and a health hazard.

- Avoid skin, eye and clothing contact with fuel.
- Immediately consult a doctor if you swallow fuel.
- Do not inhale fuel vapors.
- In case of skin contact, rinse the affected area with plenty of water.
- Rinse the eyes thoroughly with water, and consult a doctor in case of fuel contact with the eyes.
- Change your clothing in case of fuel spills on them.
- Keep fuels correctly in a suitable canister, and out of the reach of children.

**Info**

If you plan to garage the motorcycle for a longer period, perform the following steps or have them performed.

Before storing the motorcycle, check all parts for function and wear. If service, repairs, or replacements are necessary, you should do this during the storage period (less workshop overload). In this way, you can avoid long workshop waiting times at the start of the new season.

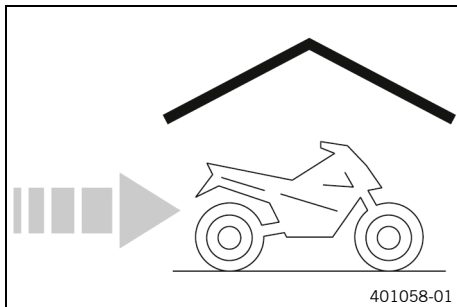

- When refueling for the last time before taking the motorcycle out of service, add fuel additive.

Fuel additive (📖 p. 124)

- Refuel. (📖 p. 29)
- Clean the motorcycle. (📖 p. 108)
- Change the gear oil. 🛠️ (📖 p. 105)
- Check the antifreeze and coolant level. (📖 p. 92)
- Check tire pressure. (📖 p. 88)
- Empty the carburetor float chamber. 🛠️ (📖 p. 102)
- Store the vehicle in a dry location that is not subject to large fluctuations in temperature.

**Info**

KTM recommends jacking up the motorcycle.

- Raise the motorcycle with a lift stand. (📖 p. 44)
- Cover the vehicle with a tarp or similar cover that is permeable to air.

**Info**

Do not use non-porous materials since they prevent humidity from escaping, thus causing corrosion. Avoid running the engine for a short time only. Because the engine will not warm up sufficiently, the water vapor produced during combustion will condense, causing engine parts and the exhaust system to rust.

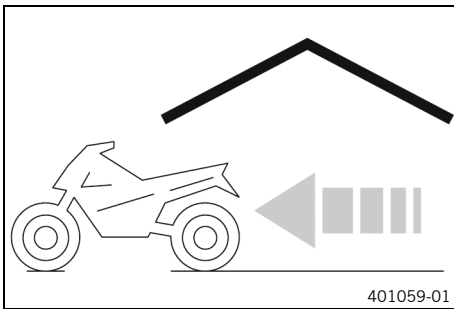

**18.2 Preparing for use after storage**

- Remove the motorcycle from the lift stand. (📖 p. 44)
- Perform checks and maintenance measures when preparing for use. (📖 p. 26)
- Take a test ride.



Faults	Possible cause	Action
Engine turns but does not start	Operating error	– Carry out the start procedure. (📖 p. 26)
	Motorcycle was out of use for a long time and there is old fuel in the float chamber	– Empty the carburetor float chamber. 🛠️ (📖 p. 102)
	Fuel supply interrupted	– Check the fuel tank breather. – Clean the fuel tap. – Check/adjust the carburetor components.
	Spark plug sooty or wet	– Clean and dry the spark plug and spark plug connector, or change if necessary.
	Plug gap of spark plug too wide	– Adjust plug gap. Guideline Spark plug electrode gap 0.60 mm (0.0236 in)
	Fault in ignition system	– Check the ignition system. 🛠️ – Adjust the ignition system. 🛠️
	Short-circuit cable in wiring harness frayed, stop button faulty	– Check the stop button. 🛠️
	Water in carburetor or jets blocked	– Check/set the carburetor components.
The engine has no idle speed	Idling jet blocked	– Check/set the carburetor components.
	Adjusting screws on carburetor distorted	– Carburetor – adjust the idle speed. 🛠️ (📖 p. 101)
	Spark plug defective	– Change the spark plug.
	Ignition system defective	– Check the ignition coil. 🛠️ – Check the spark plug connector. 🛠️
Engine does not speed up	Carburetor running over because float needle dirty or worn	– Check/set the carburetor components.
	Loose carburetor jets	– Check/set the carburetor components.
	Fault in ignition system	– Check the ignition system. 🛠️ – Adjust the ignition system. 🛠️
Engine has too little power	Fuel supply interrupted	– Check the fuel tank breather. – Clean the fuel tap. – Check/adjust the carburetor components.
	Air filter is very dirty	– Clean the air filter and air filter box. 🛠️ (📖 p. 57)
	Exhaust system leaks, deformed or too little glass fiber yarn filling in main silencer	– Check exhaust system for damage. – Change the glass fiber yarn filling of the main silencer. 🛠️ (📖 p. 58)
	Fault in ignition system	– Check the ignition system. 🛠️ – Adjust the ignition system. 🛠️
	Membrane or reed valve housing is damaged	– Check the membrane and reed valve housing.

Faults	Possible cause	Action
Engine stalls or is popping into the carburetor	Lack of fuel	<ul style="list-style-type: none"> <li>– Turn tap handle of the fuel tap to the <b>ON</b> position.</li> <li>– Refuel. (📖 p. 29)</li> </ul>
	Engine takes in bad air	– Check intake flange and carburetor for tightness.
	The connector or ignition coil is loose or oxidized	– Clean the connector and treat it with contact spray.
Engine overheats	Too little coolant in cooling system	<ul style="list-style-type: none"> <li>– Check the cooling system for leaks.</li> <li>– Check the coolant level. (📖 p. 93)</li> </ul>
	Too little air stream	– Switch off the engine when standing.
	Radiator fins very dirty	– Clean the radiator fins.
	Foam formation in cooling system	<ul style="list-style-type: none"> <li>– Drain the coolant. 🛠️ (📖 p. 93)</li> <li>– Refill with coolant. 🛠️ (📖 p. 94)</li> </ul>
	Damaged cylinder head or cylinder head gasket	– Check the cylinder head and cylinder head gasket.
	Bent radiator hose	– Change the radiator hose. 🛠️
	Incorrect ignition point due to loose stator	– Adjust the ignition system. 🛠️
White smoke emission (steam in exhaust gas)	Damaged cylinder head or cylinder head gasket	– Check the cylinder head and cylinder head gasket.
Gear oil exits at the vent hose	Too much gear oil added	– Check the gear oil level. (📖 p. 105)
Water in the gear oil	Damaged radial shaft seal ring or water pump	– Check the radial shaft seal ring and the water pump.

## 20.1 Engine

Design	1-cylinder 2-stroke engine, water-cooled, with reed intake and exhaust control
Displacement	84.93 cm <sup>3</sup> (5.1828 cu in)
Stroke	48.95 mm (1.9272 in)
Bore	47 mm (1.85 in)
Idle speed	1,400 ... 1,500 rpm
Crankshaft bearing	1 grooved ball bearing / 1 roller bearing
Conrod bearing	Needle bearing
Piston pin bearing	Needle bearing
Pistons	Aluminum cast
Piston rings	1 rectangular ring
Engine lubrication	Mixed lubrication
Primary transmission	20:64 straight cut spur gear wheel drive
Clutch	Multidisc clutch in oil bath/hydraulically activated
Transmission	6-gear transmission, claw shifted
Transmission ratio	
1st gear	11:29
2nd gear	14:28
3rd gear	16:26
4th gear	19:26
5th gear	21:25
6th gear	20:21
Ignition	Kokusan 504
Spark plug	NGK BR9 ECMVX
Spark plug electrode gap	0.60 mm (0.0236 in)
Cooling	Water-cooled
Starting aid	Kick starter lever

## 20.2 Engine tightening torques

Screw, adjusting lever	M5x12	6 Nm (4.4 lbf ft)	<b>Loctite®243™</b>
Screw, clutch spring retainer	M5	6 Nm (4.4 lbf ft)	
Screw, control lever	M5x12	6 Nm (4.4 lbf ft)	<b>Loctite®243™</b>
Screw, crankshaft speed sensor	M5	6 Nm (4.4 lbf ft)	<b>Loctite®243™</b>
Screw, exhaust control bearing support	M5	6 Nm (4.4 lbf ft)	<b>Loctite®243™</b>
Screw, exhaust control cap	M5	4 Nm (3 lbf ft)	
Screw, exhaust control cover	M5	5 Nm (3.7 lbf ft)	
Screw, guide piece	M5x12	6 Nm (4.4 lbf ft)	<b>Loctite®243™</b>
Screw, ignition system/stator	M5	6 Nm (4.4 lbf ft)	<b>Loctite®243™</b>

Screw, locking lever	M5	6 Nm (4.4 lbf ft)	<b>Loctite®243™</b>
Screw, power valve stop plate	M5x12	6 Nm (4.4 lbf ft)	<b>Loctite®243™</b>
Screw, water pump wheel	M5	6 Nm (4.4 lbf ft)	<b>Loctite®243™</b>
Coolant drain plug	M6	8 Nm (5.9 lbf ft)	
Nut, adjusting screw, power valve	M6	8 Nm (5.9 lbf ft)	
Screw, alternator cover	M6	8 Nm (5.9 lbf ft)	
Screw, bearing retainer	M6	10 Nm (7.4 lbf ft)	<b>Loctite®243™</b>
Screw, clutch cover	M6x25	10 Nm (7.4 lbf ft)	
Screw, clutch cover	M6x55	10 Nm (7.4 lbf ft)	
Screw, clutch cover	M6x60	10 Nm (7.4 lbf ft)	
Screw, clutch slave cylinder	M6	10 Nm (7.4 lbf ft)	
Screw, cylinder head	M6	10 Nm (7.4 lbf ft)	
Screw, engine case	M6x45	10 Nm (7.4 lbf ft)	
Screw, engine case	M6x50	10 Nm (7.4 lbf ft)	
Screw, engine sprocket cover	M6	10 Nm (7.4 lbf ft)	
Screw, exhaust flange	M6	10 Nm (7.4 lbf ft)	
Screw, gear oil level monitoring	M6	8 Nm (5.9 lbf ft)	
Screw, intake flange	M6	6 Nm (4.4 lbf ft)	
Screw, kick starter intermediate gear	M6	10 Nm (7.4 lbf ft)	<b>Loctite®243™</b>
Screw, kick starter lever stop plate	M6	10 Nm (7.4 lbf ft)	<b>Loctite®243™</b>
Screw, outer clutch cover	M6x25	8 Nm (5.9 lbf ft)	
Screw, outer clutch cover	M6x55	8 Nm (5.9 lbf ft)	
Screw, outer clutch cover	M6x60	8 Nm (5.9 lbf ft)	
Screw, radiator bleeding	M6	8 Nm (5.9 lbf ft)	
Screw, shift drum locating	M6	10 Nm (7.4 lbf ft)	<b>Loctite®243™</b>
Screw, shift lever	M6	14 Nm (10.3 lbf ft)	<b>Loctite®243™</b>
Screw, water pump cover	M6	10 Nm (7.4 lbf ft)	
Vacuum connection	M6	2 Nm (1.5 lbf ft)	
Nut, cylinder base	M8	23 Nm (17 lbf ft)	
Screw, cylinder base	M8	10 Nm (7.4 lbf ft)	
Screw, kick starter lever	M8	25 Nm (18.4 lbf ft)	<b>Loctite®243™</b>
Oil drain plug with magnet	M12	20 Nm (14.8 lbf ft)	
Nut, rotor	M12x1	60 Nm (44.3 lbf ft)	
Nut, primary gear wheel	M14LHx1.25	60 Nm (44.3 lbf ft)	<b>Loctite®243™</b>
Spark plug	M14x1.25	25 Nm (18.4 lbf ft)	
Nut, inner clutch hub	M16x1.5	60 Nm (44.3 lbf ft)	<b>Loctite®243™</b>

## 20.3 Carburetor

Carburetor type	KEIHIN PWK 28
Needle position	3rd position from top
Idle air adjusting screw	
open	2 turns
Main jet	142 (140, 145, 148)
Jet needle	NRKC (NRJC)
Idling jet	48 (45, 50)
Throttle slide	3
Choke nozzle	62

### 20.3.1 Basic carburetor setting for sandy surfaces

Idle air adjusting screw	2 turns
Idling jet	48
Jet needle	NRJ C
Needle position	4th position from top
Main jet	148



#### Info

If the engine is not running smoothly, use a smaller main jet.

### 20.3.2 Carburetor tuning ↗

#### KEIHIN PWK 28

ASL	TEMP	-20 ... -7 °C (-4 ... 19 °F)	-6 ... 5 °C (21 ... 41 °F)	6 ... 15 °C (43 ... 59 °F)	16 ... 24 °C (61 ... 75 °F)	25 ... 36 °C (77 ... 97 °F)	37 ... 49 °C (99 ... 120 °F)
2,301 ... 3,000 m (7,549 ... 9,843 ft)	ASO IJ NDL POS MJ	2 48 NRK C 3 142	2 45 NRK C 3 142	1.5 42 NRK C 3 140	2 42 NRK C 3 138	1.5 42 NRJ C 3 138	
1,501 ... 2,300 m (4,925 ... 7,546 ft)	ASO IJ NDL POS MJ	2 48 NRK C 3 145	2 48 NRK C 3 142	2 45 NRK C 3 142	1.5 42 NRK C 3 140	2 42 NRK C 3 138	1.5 42 NRJ C 3 138
751 ... 1,500 m (2,464 ... 4,921 ft)	ASO IJ NDL POS MJ	2 48 NRJ C 4 145	2 48 NRK C 3 145	2 48 NRK C 3 142	2 45 NRK C 3 142	1.5 42 NRK C 3 140	2 42 NRK C 3 138
301 ... 750 m (988 ... 2,461 ft)	ASO IJ NDL POS MJ	2 48 NRJ C 4 148	1.5 48 NRK C 3 148	2 48 NRK C 3 145	<b>2</b> <b>48</b> NRK C 3 <b>142</b>	2 45 NRK C 3 142	1.5 42 NRK C 3 140

ASL	TEMP	-20 ... -7 °C (-4 ... 19 °F)	-6 ... 5 °C (21 ... 41 °F)	6 ... 15 °C (43 ... 59 °F)	16 ... 24 °C (61 ... 75 °F)	25 ... 36 °C (77 ... 97 °F)	37 ... 49 °C (99 ... 120 °F)
0 ... 300 m (0 ... 984 ft)	ASO IJ NDL POS MJ	2 48 NRJ C 4 148	1.5 48 NRK C 3 148	2 48 NRK C 3 145	2 48 NRK C 3 142	2 45 NRK C 3 142	1.5 42 NRK C 3 140

M/FT ASL	Above sea level
TEMP	Temperature
ASO	Open (rotations) idle air adjusting screw
IJ	Idling jet
NDL	Jet needle
POS	Needle position from top
MJ	Main jet

## 20.4 Capacities

### 20.4.1 Gear oil

Gear oil	0.50 l (0.53 qt.)	Engine oil (15W/50) (📖 p. 122)
----------	-------------------	--------------------------------

### 20.4.2 Coolant

Coolant	0.8 l (0.8 qt.)	Coolant (📖 p. 122)
---------	-----------------	--------------------

### 20.4.3 Fuel

Fuel tank capacity, approx.	5.2 l (1.37 US gal)	Super unleaded (98 octane) mixed with 2-stroke engine oil (1:40) (📖 p. 123)
-----------------------------	---------------------	---

## 20.5 Chassis

Frame	Central tube frame of chrome molybdenum steel tubing, powder-coated
Fork	<b>WP Suspension XACT 5543</b>
Shock absorber	<b>WP Suspension XACT 5746</b>
Suspension travel	
front	278 mm (10.94 in)
rear	305 mm (12.01 in)
Fork offset	14 mm (0.55 in)
Brake system	
front	Disc brake with 2-piston brake caliper
rear	Disc brake with 1-piston brake caliper
Brake discs - diameter	
front	240 mm (9.45 in)
rear	220 mm (8.66 in)
Brake discs - wear limit	
front	3.5 mm (0.138 in)

rear	3.7 mm (0.146 in)
Offroad tire pressure	
front	1.0 bar (15 psi)
rear	1.0 bar (15 psi)
Secondary ratio (85 SX 17/14)	13:46
Secondary ratio (85 SX 19/16)	13:49
Chain	1/2 x 5/16"
Rear sprockets available	44, 45, 46, 47, 48, 49, 50, 51
Steering head angle	66°
Wheelbase	1,290 ± 10 mm (50.79 ± 0.39 in)
Seat height, unloaded (85 SX 17/14)	865 mm (34.06 in)
Seat height, unloaded (85 SX 19/16)	890 mm (35.04 in)
Ground clearance, unloaded (85 SX 17/14)	336 mm (13.23 in)
Ground clearance, unloaded (85 SX 19/16)	362 mm (14.25 in)
Weight without fuel, approx. (85 SX 17/14)	67 kg (148 lb.)
Weight without fuel, approx. (85 SX 19/16)	68 kg (150 lb.)
Maximum rider weight	75 kg (165 lb.)

## 20.6 Tires

Validity	Front tire	Rear tire
(85 SX 17/14)	<b>70/100 - 17 M/C 40M TT</b> MAXXIS MAXX CROSS SI	<b>90/100 - 14 M/C 49M TT</b> MAXXIS MAXX CROSS SI
(85 SX 19/16)	<b>70/100 - 19 M/C 42M TT</b> MAXXIS MAXX CROSS SI	<b>90/100 - 16 M/C 52M TT</b> MAXXIS MAXX CROSS SI

The tires specified represent one of the possible series production tires. Additional information is available in the Service section under:  
KTM.COM

## 20.7 Fork

Fork article number	43.18.8U.04	
Fork	<b>WP Suspension XACT 5543</b>	
Compression damping		
Comfort	17 clicks	
Standard	12 clicks	
Sport	7 clicks	
Rebound damping		
Comfort	17 clicks	
Standard	12 clicks	
Sport	7 clicks	
Air pressure	5 bar (73 psi)	
Fork length	845 mm (33.27 in)	
Oil capacity external mechanism right	363 ± 10 ml (12.27 ± 0.34 fl. oz.)	Fork oil (SAE 4) (48601166S1) (📖 p. 123)
Oil capacity external mechanism left	100 ± 20 ml (3.38 ± 0.68 fl. oz.)	Fork oil (SAE 4) (48601166S1) (📖 p. 123)



Grease capacity, left cartridge	5 g (0.18 oz)	Special grease (00062010053) (📖 p. 125)
---------------------------------	---------------	--

## 20.8 Shock absorber

Shock absorber article number	12.18.7U.04
Shock absorber	<b>WP SuspensionXACT 5746</b>
High-speed compression damping	
Comfort	2.5 turns
Standard	2 turns
Sport	1.5 turns
Low-speed compression damping	
Comfort	18 clicks
Standard	15 clicks
Sport	12 clicks
Rebound damping	
Comfort	18 clicks
Standard	15 clicks
Sport	12 clicks
Spring preload	11 mm (0.43 in)
Spring rate	
Weight of rider: < 45 kg (< 99 lb.)	35 N/mm (200 lb/in)
Weight of rider: 45 ... 55 kg (99 ... 121 lb.)	40 N/mm (228 lb/in)
Weight of rider: > 55 kg (> 121 lb.)	45 N/mm (257 lb/in)
Spring length	215 mm (8.46 in)
Gas pressure	10 bar (145 psi)
Static sag	30 mm (1.18 in)
Riding sag	120 mm (4.72 in)
Fitted length	397 mm (15.63 in)
Shock absorber fluid (📖 p. 123)	SAE 2.5

## 20.9 Chassis tightening torques

Screw, stop button	M3	0.4 Nm (0.3 lbf ft)
Screw, carburetor cover	M4	2 Nm (1.5 lbf ft)
Screw, fixed grip	M4	5 Nm (3.7 lbf ft)
Spoke nipple	M4.5	5 Nm (3.7 lbf ft)
Remaining nuts, chassis	M5	5 Nm (3.7 lbf ft)
Remaining screws, chassis	M5	5 Nm (3.7 lbf ft)
Screw, main silencer	M5	7 Nm (5.2 lbf ft)
Screw, shock absorber adjusting ring	M5	5 Nm (3.7 lbf ft)
Nut, push rod, foot brake lever	M6	6 Nm (4.4 lbf ft)
Pin, front brake	M6	8 Nm (5.9 lbf ft)
Pin, rear brake	M6	4 Nm (3 lbf ft)
Remaining nuts, chassis	M6	10 Nm (7.4 lbf ft)

**Loctite®243™**

Remaining screws, chassis	M6	10 Nm (7.4 lbf ft)
Screw for throttle grip	M6	5 Nm (3.7 lbf ft)
Screw, ball joint of push rod on foot brake cylinder	M6	10 Nm (7.4 lbf ft) <b>Loctite®243™</b>
Screw, clutch assembly on handlebar	M6	5 Nm (3.7 lbf ft)
Screw, foot brake cylinder	M6	10 Nm (7.4 lbf ft)
Screw, front brake assembly on handlebar	M6	5 Nm (3.7 lbf ft)
Screw, front brake disc	M6	14 Nm (10.3 lbf ft) <b>Loctite®243™</b>
Screw, front fender	M6	6 Nm (4.4 lbf ft)
Screw, fuel tank spoiler on radiator	M6	6 Nm (4.4 lbf ft)
Screw, ignition coil	M6	6.4 Nm (4.72 lbf ft)
Screw, rear brake disc	M6	14 Nm (10.3 lbf ft) <b>Loctite®243™</b>
Start number plate screw	M6	4 Nm (3 lbf ft)
Throttle cable wire on carburetor cover	M6x0.75	3 Nm (2.2 lbf ft)
Nut, rim lock	M8	10 Nm (7.4 lbf ft)
Remaining nuts, chassis	M8	25 Nm (18.4 lbf ft)
Remaining screws, chassis	M8	25 Nm (18.4 lbf ft)
Screw, bottom triple clamp	M8	15 Nm (11.1 lbf ft)
Screw, chain sliding piece	M8	15 Nm (11.1 lbf ft)
Screw, engine brace	M8	25 Nm (18.4 lbf ft) <b>Loctite®2701™</b>
Screw, engine sprocket cover	M8	15 Nm (11.1 lbf ft)
Screw, foot brake lever stop	M8	20 Nm (14.8 lbf ft)
Screw, fork stub	M8	15 Nm (11.1 lbf ft)
Screw, front brake caliper	M8	25 Nm (18.4 lbf ft) <b>Loctite®243™</b>
Screw, handlebar clamp	M8	20 Nm (14.8 lbf ft)
Screw, rear brake caliper	M8	18 Nm (13.3 lbf ft) <b>Loctite®243™</b>
Screw, rear sprocket	M8	35 Nm (25.8 lbf ft) <b>Loctite®2701™</b>
Screw, subframe	M8	35 Nm (25.8 lbf ft) <b>Loctite®2701™</b>
Screw, top triple clamp	M8	17 Nm (12.5 lbf ft)
Steering stem clamp screw	M8	20 Nm (14.8 lbf ft)
Engine carrying screw	M10	45 Nm (33.2 lbf ft)
Nut, foot brake lever	M10	45 Nm (33.2 lbf ft) <b>Loctite®243™</b>
Remaining nuts, chassis	M10	45 Nm (33.2 lbf ft)
Remaining screws, chassis	M10	45 Nm (33.2 lbf ft)
Screw, handlebar support	M10	40 Nm (29.5 lbf ft) <b>Loctite®243™</b>

Screw, bottom shock absorber	M12	60 Nm (44.3 lbf ft) <b>Loctite®2701™</b>
Screw, top shock absorber	M12	60 Nm (44.3 lbf ft) <b>Loctite®2701™</b>
Nut, seat fixing	M12x1	20 Nm (14.8 lbf ft)
Nut, swingarm pivot	M14x1.5	75 Nm (55.3 lbf ft)
Nut, rear wheel spindle	M20x1.5	80 Nm (59 lbf ft)
Nut, steering stem	M20x1.5	10 Nm (7.4 lbf ft)
Screw, front wheel spindle	M20x1.5	35 Nm (25.8 lbf ft)

## Brake fluid DOT 4 / DOT 5.1

### Standard/classification

- DOT

### Guideline

- Use only brake fluid that complies with the specified standard (see specifications on the container) and that exhibits the corresponding properties.

### Recommended supplier

#### Castrol

- REACT PERFORMANCE DOT 4

#### MOTOREX®

- Brake Fluid DOT 5.1

## Coolant

### Guideline

- Only use high-grade, silicate-free coolant with corrosion inhibitor additive for aluminum motors. Low grade and unsuitable antifreeze causes corrosion, deposits and frothing.
- Do not use pure water as only coolant is able to meet the requirements needed in terms of corrosion protection and lubrication properties.
- Only use coolant that complies with the requirements stated (see specifications on the container) and that has the relevant properties.

Antifreeze protection to at least	-25 °C (-13 °F)
-----------------------------------	-----------------

The mixture ratio must be adjusted to the necessary antifreeze protection. Use distilled water if the coolant needs to be diluted.

The use of premixed coolant is recommended.

Observe the coolant manufacturer specifications for antifreeze protection, dilution and miscibility (compatibility) with other coolants.

### Recommended supplier

#### MOTOREX®

- COOLANT M3.0

## Engine oil (15W/50)

### Standard/classification

- JASO T903 MA2 (📖 p. 126)
- SAE (📖 p. 126) (15W/50)

### Guideline

- Use only engine oils that comply with the specified standards (see specifications on the container) and that possess the corresponding properties.

### Recommended supplier

#### MOTOREX®

- Top Speed 4T

## Engine oil, 2-stroke

### Standard/classification

- JASO FD (📖 p. 126)

### Guideline

- Only use high-grade 2-stroke engine oil from a reputable brand.

fully synthetic
-----------------

**Recommended supplier**

**MOTOREX®**

- Cross Power 2T

**Fork oil (SAE 4) (48601166S1)**

**Standard/classification**

- SAE (📖 p. 126) (SAE 4)

**Guideline**

- Use only oils that comply with the specified standards (see specifications on the container) and that exhibit the corresponding properties.

**Shock absorber fluid (SAE 2.5) (50180751S1)**

**Standard/classification**

- SAE (📖 p. 126) (SAE 2.5)

**Guideline**

- Use only oils that comply with the specified standards (see specifications on the container) and that exhibit the corresponding properties.

**Super unleaded (ROZ 98 / RON 98 / PON 94)**

**Standard/classification**

- DIN EN 228 (ROZ 98 / RON 98 / PON 94)

**Super unleaded (98 octane) mixed with 2-stroke engine oil (1:40)**

**Standard/classification**

- DIN EN 228
- JASO FD (📖 p. 126) (1:40)

**Mixture ratio**

1:40	Engine oil, 2-stroke (📖 p. 122) Super unleaded (ROZ 98 / RON 98 / PON 94) (📖 p. 123)
------	---

**Recommended supplier**

**MOTOREX®**

- Cross Power 2T

### Air filter cleaner

Recommended supplier

MOTOREX®

- Racing Bio Dirt Remover

### Chain cleaner

Recommended supplier

MOTOREX®

- Chain Clean

### Fuel additive

Recommended supplier

MOTOREX®

- Fuel Stabilizer

### High viscosity grease

Recommended supplier

SKF®

- LGHB 2

### Long-life grease

Recommended supplier

MOTOREX®

- Bike Grease 2000

### Motorcycle cleaner

Recommended supplier

MOTOREX®

- Moto Clean

### Off-road chain spray

Recommended supplier

MOTOREX®

- Chainlube Offroad

### Oil for foam air filter

Recommended supplier

MOTOREX®

- Racing Bio Liquid Power

### Preserving materials for paints, metal and rubber

Recommended supplier

MOTOREX®

- Moto Protect

**Rubber grip adhesive (00062030051)**

Recommended supplier

KTM AG

- GRIP GLUE

**Special cleaner for glossy and matte paint finishes, metal and plastic surfaces**

Recommended supplier

MOTOREX®

- Quick Cleaner

**Special grease (00062010053)**

Recommended supplier

Klüber Lubrication®

- KLÜBERFOOD NH1 34-401

**Universal oil spray**

Recommended supplier

MOTOREX®

- Joker 440 Synthetic

### **JASO T903 MA2**

Different technical development directions required a separate specification for motorcycles – the **JASO T903 MA2** standard.

Earlier, engine oils from the automobile industry were used for motorcycles because there was no separate motorcycle specification.

Whereas long service intervals are demanded for automobile engines, the focus for motorcycle engines is on high performance at high engine speeds.

In most motorcycle engines, the transmission and clutch are lubricated with the same oil.

The **JASO T903 MA2** standard meets these special requirements.

### **SAE**

The SAE viscosity classes were defined by the Society of Automotive Engineers and are used for classifying oils according to their viscosity. The viscosity describes only one property of oil and says nothing about quality.

### **JASO FD**

JASO FD is a classification for a 2-stroke engine oil that was specifically developed for the extreme demands of racing. Thanks to first-rate synthetic esters and specially designed additives, superb combustion is achieved even under extreme operating conditions.



Art. no.	Article number
ca.	circa
cf.	compare
e.g.	for example
etc.	et cetera
i.a.	inter alia
no.	number
poss.	possibly

# PARENTS, YOUNGSTERS & OFF-HIGHWAY MOTORCYCLES



THE MSF  
**DIRTBIKE**  
SCHOOL™

The information contained in this publication is offered for the benefit of those who have an interest in riding off-highway motorcycles. The information has been compiled from publications, interviews and observations of individuals and organizations familiar with the use of off-highway motorcycles. Because there are many differences in product design, riding terrain and riding styles, there may be organizations and individuals who hold differing opinions. Consult your local motorcycle dealers or experienced off-highway motorcycle riders about appropriate riding locations in your area. Although the Motorcycle Safety Foundation will continue to publish responsible viewpoints on this subject, it must disclaim specific or general liability for the views expressed herein.

The Motorcycle Safety Foundation® (MSF) is a national not-for-profit organization promoting the safety of motorcyclists with programs in rider training, operator licensing and public information. The MSF is sponsored by BMW, BRP, Ducati, Harley-Davidson, Honda, Kawasaki, KTM, Piaggio, Polaris Motorcycles, Suzuki, Triumph and Yamaha.

**Motorcycle Safety Foundation**  
**2 Jenner, Suite 150**  
**Irvine, CA 92618**  
**949.727.3227**  
**[msf-usa.org](http://msf-usa.org)**

Copyright 2015  
Printed: March 2015

# Parents...Be Cautious

---

Riding Off-Highway Motorcycles (OHMs) can be an enjoyable form of outdoor recreation when done properly. With preparation, practice, and parental supervision your youngster can safely develop and expand his or her riding skills. Remember, off-highway motorcycles are not toys.

This manual is designed to assist you in the important task of teaching your youngster the safe and responsible use of an off-highway motorcycle. We urge you to read this booklet thoroughly. Also read other information provided with the motorcycle. The owner's manual contains important warnings and features of the motorcycle.

Deciding if your youngster is ready to ride an off-highway motorcycle is an important decision. The MSF strongly urges you to carefully determine your youngster's readiness to ride. There is a Readiness Checklist in Part 4 of this booklet. **Do not permit youngsters to ride an off-highway motorcycle if you doubt that they will operate the motorcycle safely.**

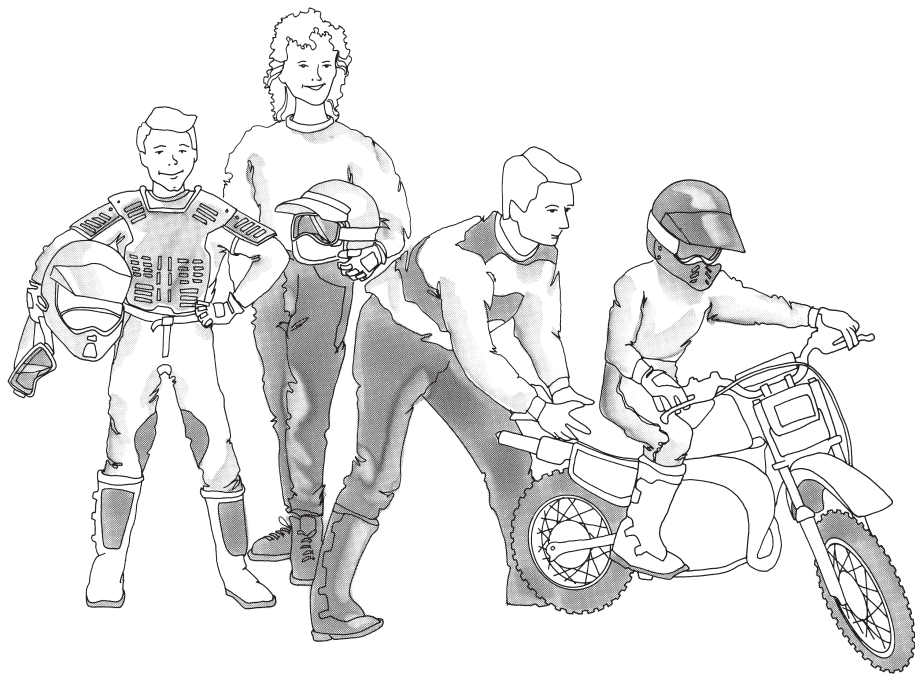

# CONTENTS

## **INTRODUCTION**

- Purpose of the Booklet 4
- Important Note to Parents 4
- Other Sources of Information 5

## **PART 1: Determining Your Youngster's Readiness to Ride an Off-Highway Motorcycle**

- Readiness Guidelines 6
- Steps for Safe and  
Responsible OHM Riding 10

## **PART 2: Pre-Operating Procedures and Practice**

- Protective Gear and Clothing 11
- Mounting/Dismounting 12
- Mastering the Controls 13
- Learning Activities 16

## **PART 3: Operating Procedures and Practice**

- Learning Area/Riding Area 20
- Getting Used to the Vehicle in  
Motion 22
- Let's Start Riding 25

## **PART 4: Readiness Checklist**

- Visual Perception/Motor/  
Development 29
- Physical Development 32
- Social/Emotional Development 34
- Reasoning and Decision-Making  
Ability 36

**FINAL NOTE: To Parents** 38

**GLOSSARY** 39

**ANSWERS** 41

# INTRODUCTION

---

## Purpose of the Booklet

---

**P**arents, *Youngsters and Off-Highway Motorcycles* is designed to assist you in determining if your youngster is ready to ride off-highway motorcycles (OHMs). It also provides you and your youngster with important safety information and tips on learning to ride. This booklet is divided into four parts: Part 1: Determining Your Youngster's Readiness to Ride an Off-highway Motorcycle; Part 2: Pre-operating Procedures; Part 3: Operating Procedures; Part 4: Readiness Checklist. There is information about protective gear, mounting, control operation and starting the engine. Operating procedures include starting, shifting, stopping and turning.

## Important Note To Parents

---

Once your youngster is ready to learn to ride, YOU must be familiar with the motorcycle. You will be serving as teacher, coach, and safety supervisor for your youngster. You must know the controls, handling characteristics, maintenance requirements, and proper riding techniques. Read and understand the owner's manual and the labels provided with the vehicle. Review all instructions, requirements, and warnings with your youngster. Find out about state or local off-highway motorcycle requirements.

## Other Sources Of Information

In addition to the information provided in *Parents, Youngsters and Off-Highway Motorcycles*, there are other sources for obtaining safety information. The owner's manual provides specific maintenance and operating procedures for your motorcycle. It also includes warnings and cautions, as well as operating tips. Motorcycle dealers may have other literature and safety information. Another booklet, *Tips and Practice Guide for the Off-Highway Motorcyclist*, gives detailed riding procedures.

The MSF *DirtBike School*<sup>SM</sup> offers training on how to ride off-highway motorcycles. The course is available to youth as young as six years of age, as well as to adults. Call toll-free 877.288.7093 to enroll or for more information. To find out more on the internet, visit [dirtbikeschool.com](http://dirtbikeschool.com).

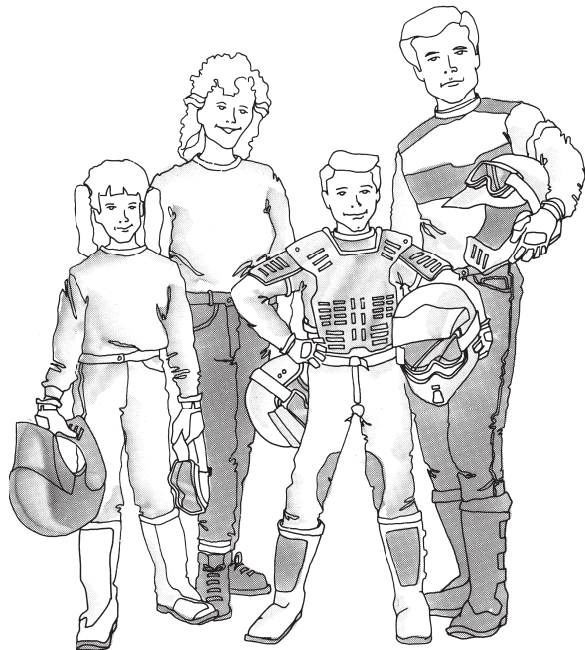



# PART 1

## DETERMINING YOUR YOUNGSTER'S READINESS TO RIDE AN OFF-HIGHWAY MOTORCYCLE

---

**T**he first important decision you will have to make concerning your youngster and off-highway motorcycles (OHMs) is whether your youngster is ready to ride. There are several factors that you must consider carefully.

There is no certain way to predict that your child is able to ride an OHM safely. However, the following information is a guide to help you determine your youngster's readiness to ride. Only parents can decide if their youngster has the qualities necessary to operate an off-highway motorcycle safely.

### Readiness Guidelines

---

#### **PHYSICAL DEVELOPMENT**

Physical size and ability are important considerations. For example, a youngster must be big enough to hold the motorcycle up, get on, and comfortably sit on the seat with both feet touching the ground.

Also make sure your youngster can comfortably reach and work all the controls. For example, can they turn the handlebars all the way to the right and left? Can they easily use their feet to work the brake pedal and gearshift lever? Can they operate the throttle and brake levers while they hold onto the handgrips? If not, the youngster is not physically ready to ride this OHM. Refer to the owner's manual to check for possible adjustments in the position of some of the controls.

# PART 1

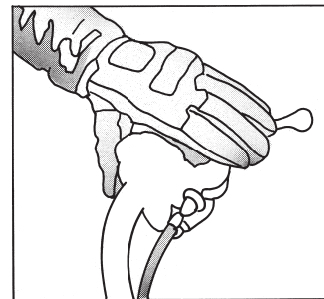
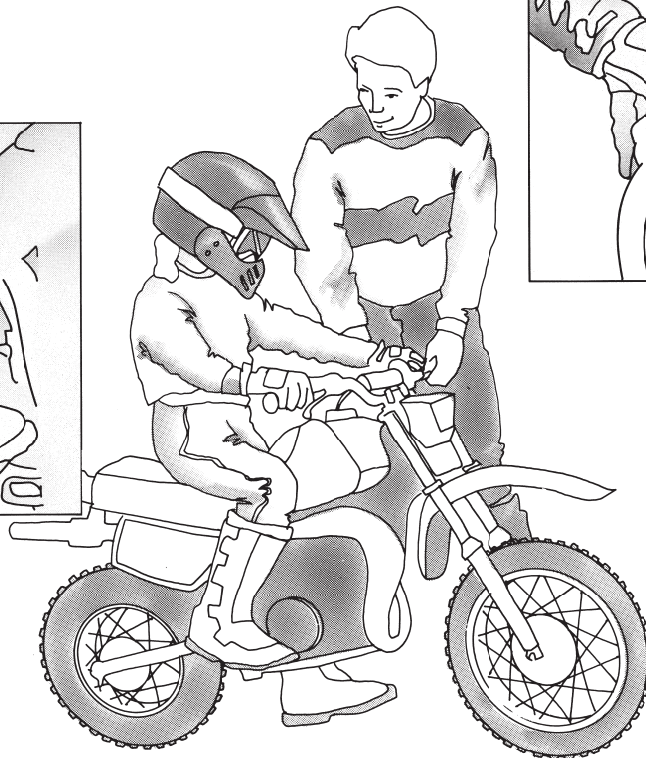
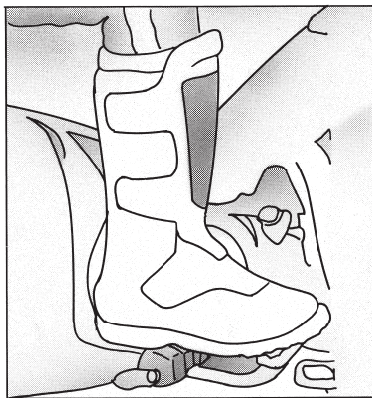

# PART 1

---

Additional signs of physical readiness can be observed in your youngster's other play activities. In general, a youngster should be well-coordinated, having good balance and agility. This coordination can be demonstrated by the abilities to jump rope, skate, skateboard, ride a bicycle, etc. If a youngster cannot perform well in these types of activities, more physical development is needed.

## **SOCIAL/EMOTIONAL DEVELOPMENT**

How a youngster behaves in a social setting can be a sign of social/emotional development. A youngster needs to know about and understand rules. Certain rules are necessary for the safe operation of any vehicle. Youngsters must be willing to follow rules. A good sign is a youngster who obeys rules set by parents. A youngster who does not follow rules is not ready for an OHM.

One indicator that a youngster is ready to ride an

OHM is when they demonstrate a safety-conscious attitude and are aware of possible injury from reckless OHM operation. If the youngster has a habit of recklessness or is often involved in accidents while using bicycles or skateboards, the youngster is not ready to ride an OHM.

## **REASONING AND DECISION-MAKING ABILITY**

Youngsters should have some knowledge about what may happen if something is done wrong. They must understand that unsafe actions can result in injury. An example of this is knowing the need to look in both directions before crossing a street when walking to school. The ability to make good decisions relates to a youngster's ability to reason. When presented with a problem, the youngster should be able to come up with a sensible answer. Ask your youngster to tell you what causes accidents and injuries. Your youngster needs to be able to tell

what causes accidents and how to avoid them. In general, a youngster should understand that he or she can get hurt as a result of making poor choices.

## **VISUAL PERCEPTIONS AND MOTOR DEVELOPMENT**

This area involves how well a youngster sees and how vision is used with other physical movements. In other words, can a youngster see and react with the proper hand, foot, or body movement?

Several types of visual characteristics are important. The ability to see to the sides while looking straight ahead is called peripheral or side vision. You can determine a youngster's side vision by having him or her look straight ahead while you move objects to the side. The youngster should be able to see objects ninety degrees to the side while looking straight ahead. Rider awareness and safety improves with good side vision.

Being able to judge distance is another visual skill helpful when operating an OHM. Is your youngster able to tell how far one object is from another, or which of two objects is closer? OHM riding requires a person to judge distance and react properly.

Being good at playing video games, hitting a baseball, etc., is a good sign that a youngster's eye and hand movements are fairly well coordinated.

In summary, you must consider many things before you decide to put your youngster on an OHM. There is no exact formula to use in making this decision. The Readiness Checklist, Part 4, can assist you with some points to evaluate. If you are not able to check-off most of the statements, your youngster is probably not ready to ride an OHM.

# PART 1

## Steps For Safe And Responsible OHM Riding

Once you determine that OHM use is proper for your youngster, it is time to prepare yourself as a good OHM teacher and supervisor.

### **STEP ONE: Educate Yourself about OHM Safety and Proper Riding Techniques**

You must learn as much as possible about off-highway motorcycles in general, and especially your youngster's motorcycle. You must be qualified to instruct and supervise your youngster. This means that you will need to understand the features of the motorcycle and proper riding techniques. The best source of information is the owner's manual supplied with the motorcycle. Read the owner's manual before you begin to instruct your youngster about OHM safety. Pay particular attention to the warning labels and stickers on the motorcycle.

### **STEP TWO: Teach Your Youngster Safe and Proper Riding Techniques**

Teaching your youngster off-highway motorcycling is a step-by-step process. It begins with safety rules and moves to actual riding techniques. Since youngsters learn at different rates, it will be up to you to set the pace of your youngster's progress. At some point you may decide that he or she is not ready to ride an OHM.

### **STEP THREE: Avoid Unsafe Situations Through Close Supervision**

ALWAYS closely supervise your youngster's riding. This is true even if your youngster has learned and mastered the rules and skills of safe OHM riding. Youngsters can get tired easily and become careless. They do not always see everything that is important around them. Your close supervision and good judgment are important.

## Protective Gear And Clothing

**T**he nature of off-highway riding demands that your youngster wear proper protective gear. Motorcycle riders should ALWAYS wear a helmet, eye protection, gloves, long pants, a long-sleeved shirt or jacket, and over-the-ankle boots. Anything less is not adequate protection. NEVER let anyone ride an off-highway motorcycle without a Department of Transportation (DOT) compliant motorcycle helmet. Be sure the fit is correct. It should be snug but not tight. It must be properly fastened.

Protective gear is necessary in any weather, even when the temperature is warm. In cooler weather you should dress your youngster with additional layers of clothing. Some riders choose to wear a kidney belt and chest or back protector for additional protection. On the right is a drawing of well-equipped riders. Show this drawing to your youngster and point out what is important.

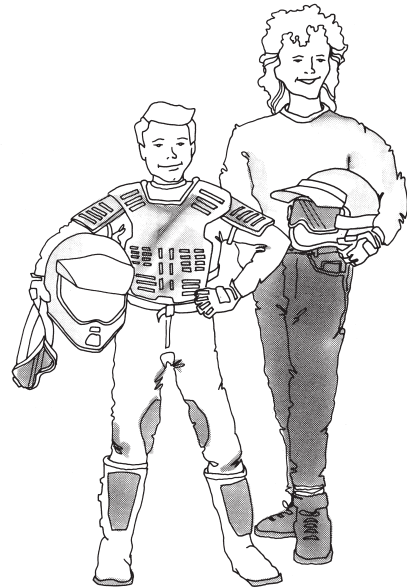

# PART 2

## Mounting/Dismounting

Have your youngster wear safety gear whenever getting on a motorcycle. This action will stress the importance of safety gear and help develop safe riding habits.

Mounting is typically from the left side. To mount from the left, point the handlebars straight. While squeezing the front brake lever, swing the right leg over the seat and place the right foot on the ground. Both feet should be in contact with the ground while sitting on the motorcycle. Dismounting reverses the procedure: the kickstand is placed fully down. With the left foot on the ground, the handlebars straight and the front brake lever squeezed, the right leg is swung over the seat and the foot touches the ground.

Correct riding posture helps your youngster operate the controls. Proper straight line riding posture includes:

- Head and eyes up, looking well ahead.
- Shoulders relaxed, back straight.

- Elbows bent, slightly out and away from the body.
- Hands on the handlebars.
- Knees in toward the tank.
- Feet on the footpegs, toes pointing straight ahead.

The hand and foot controls are important to riding safely. While riding, both hands should be kept on the handlebars and both feet on the footpegs of the motorcycle. Removing a hand or foot can reduce the ability to control the motorcycle.

An off-highway motorcycle rider will need to shift body weight in certain situations. This is especially true in maneuvers such as turning, negotiating hills, and riding on bumpy terrain. Your youngster should be able to operate the controls during these maneuvers. Now is a good time to make sure your youngster can reach the controls from different body positions. Have the youngster remount. Turn the handlebars full left

and full right. See that this can be done easily. Next have the youngster slide up and back on the seat. Mention that body movement is important. Body movement and shifting weight help to control the motorcycle.

*(Go through these control exercises with the motorcycle's engine OFF.)*

## Mastering The Controls

Show your youngster how to use each control as you describe its action. Refer to the owner's manual to learn control location and function before instructing your youngster. Test yourself by operating the controls. Have your youngster dress in the proper protective gear and sit on the machine as you point out each control. It is important to have your youngster wear all the protective gear whenever sitting on an off-highway motorcycle.

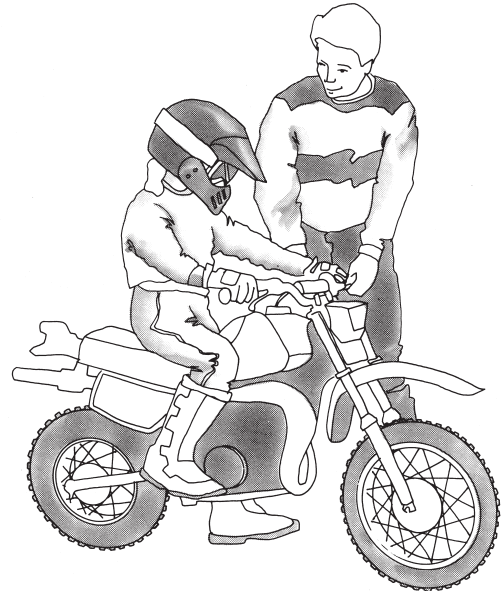



# PART 2

## **BRAKES**

Most small off-highway motorcycles have a hand lever on the right handlebar which operates the front brake. Most also have a foot pedal on the right side to operate the rear brake. Refer to the owner's manual for correct brake location and operation.

Explain and demonstrate proper braking procedure. Be sure your youngster can apply the brake(s) properly while seated and without looking down. Smooth operation should be encouraged.

## **THROTTLE CONTROL**

Explain to your youngster that twisting the throttle control back will make the motorcycle go faster. Closing the throttle control slows the motorcycle.

Youngsters need practice using the throttle control smoothly. They tend to use it like an on/off switch. With the engine off, have your youngster

move the throttle to various positions. Practice turning the handlebars and using the throttle at the same time.

## **ENGINE STOP SWITCH**

Explain to your youngster how to use the engine stop switch to turn off the engine. With the engine off, show how the stop switch works. Later, your youngster can practice using the stop switch when the engine is actually running.

## **CLUTCH/SHIFT LEVER**

Some small OHMs do not have a clutch lever; some don't have a shift lever either. This section applies only to motorcycles with a shift lever. Those that do have a shift lever may have different shift patterns. Refer to your owner's manual for proper shifting instructions. It is important to learn how the shift lever works.

Explain that it is possible to shift the motorcycle with the shift lever in order to ride at different speeds.

Have your youngster practice shifting with the engine off. The shift lever, clutch lever (if equipped), and throttle control work together to move the motorcycle. When shifting to first gear from neutral the throttle is closed, the clutch lever is squeezed, and the front brake is applied before moving the shift lever into first gear. When starting out, the front brake is released. The throttle is gradually opened while the clutch is slowly released. If the clutch is released too quickly, or too much throttle is applied, the motorcycle may lunge forward causing loss of control. With the engine off, have your youngster practice upshifts, downshifts, and locating neutral.

## **SPEED LIMITERS**

*(supervisor control feature)*

Some models come equipped with a removable exhaust restrictor, or another feature which reduces maximum speed. Refer to your owner's manual or talk to your dealer about this.

# PART 2

## Learning Activities

Here are some activities that your youngster can use to help learn about motorcycle parts and controls

### CROSSWORD PUZZLE

Here is a crossword puzzle for your youngster to complete.

#### Across

1. What this booklet is all about.
2. A piece of safety equipment for your head that you must never forget to wear.
3. Protective gear for the hands.
4. Where you should always ride your motorcycle. (a synonym)
5. Hand lever you use when shifting gears.

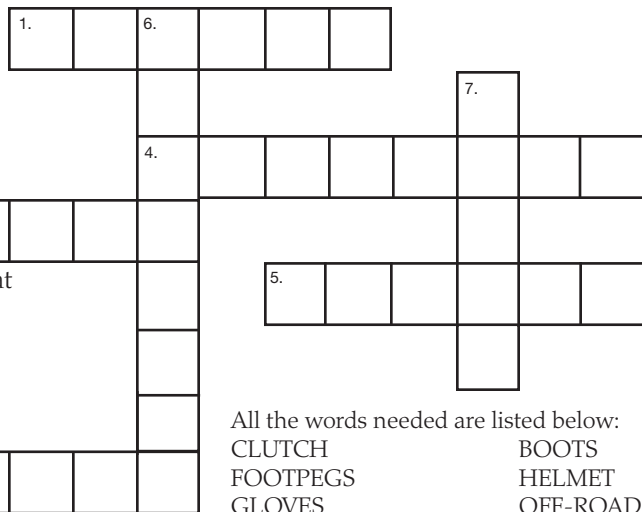

#### Down

6. The place on which you keep your feet when riding.
7. Protective gear for the feet and ankles.

All the words needed are listed below:

CLUTCH	BOOTS
FOOTPEGS	HELMET
GLOVES	OFF-ROAD
SAFETY	

*Answer Guide on Page 41*

# PART 2

## NAME THE MOTORCYCLE PARTS (Typical)

Have your youngster write the number of the motorcycle part or control on the correct line for the diagrams shown. (*Answer Guide on Page 42*)

1. Clutch lever
2. Hand brake lever
3. Foot brake lever or pedal
4. Throttle
5. Choke or enriching device
6. Engine stop switch
7. Gas cap/tank vent
8. Starter (kick)
9. Electric starter (if equipped)

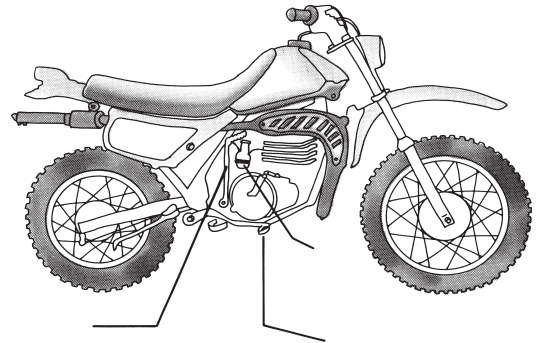
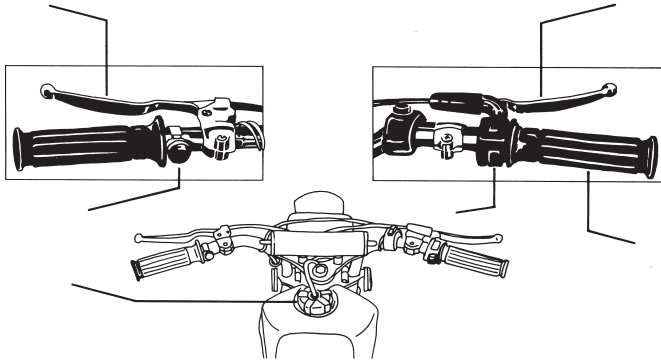

# PART 2

## LOCATING THE CONTROLS GAME

Now that you have shown your youngster the controls, it is your youngster's turn to show you. The engine remains OFF for this exercise and your youngster will be on the motorcycle. The youngster should be wearing the proper protective gear to develop this safety habit.

1. Have your youngster show you the location of the following:

- Brakes (lever and pedal)
- Throttle Control
- Engine Stop Switch
- Shift Lever (if equipped)
- Clutch (if equipped)

2. Have your youngster show you how the controls work. Be sure he or she understands the proper operation of each control. Skilled use of these controls should develop with practice. Under actual riding conditions the rider will have to watch ahead while operating the controls. Your youngster should be able to find the controls quickly without looking for them.
3. With your youngster looking ahead (pick out a point to look at), have him or her operate the controls. Repeat often while changing the order.
4. Ask your youngster to operate the controls as if actually riding. Look for smooth and precise operation.

## PRE-RIDE CHECK

Before you continue:

1. Have you determined your youngster's readiness to ride an OHM? Do not let your youngster ride if you have any doubt. (Refer to the Readiness Checklist, Part 4)
2. Have you read the owner's manual and reviewed it with your youngster?
3. Does your youngster fit the motorcycle properly?
4. Have you inspected the vehicle and maintained it according to the owner's manual?
5. Is your youngster wearing the proper protective gear? Is the mounting procedure correct?
6. Has your youngster learned to locate the motorcycle controls without looking at them? Does he or she know how to operate them smoothly?
7. Does your youngster understand that he or she must always ride off-road?
8. Have you stressed to your youngster to keep his or her feet on the footpegs while riding?

If you have completely covered all these areas, you are ready to go on to Part 3.

# PART 3

## OPERATING PROCEDURES AND PRACTICE

---

Carefully observe your youngster's first use of the motorcycle. Observe his or her readiness to ride. Only permit your youngster to continue to ride if they have the size, strength, and attitude needed to ride safely.

Show your youngster the engine, exhaust pipe, and muffler. Tell him or her not to touch these parts because they are hot while the engine is running. Explain that they will remain hot after the engine is stopped. Also explain that hands and feet must be kept away from moving parts of the motorcycle.

Your youngster's safety depends in part on the mechanical condition of the motorcycle. Be sure to inspect it thoroughly before each use. Starting and refueling of the vehicle should be done by responsible adults only. Follow a regular maintenance program. See the owner's manual for inspection details.

Even after young riders have learned the basic riding skills, direct supervision by an experienced adult is necessary AT ALL TIMES. Make sure

that all off-highway motorcycle users under your supervision get proper riding instructions. Stress that an OHM is not a toy. Follow safety precautions strictly to provide a "safety first" approach to off-highway motorcycle riding. Teaching your youngster how to ride an OHM safely will increase the enjoyment of off-highway motorcycle riding.

### Learning Area/Riding Area

---

The best place for learning is a level area 100' x 200' that is free from obstacles such as rocks, stumps, or holes. The learning area may have a loose or hard dirt surface. A grassy surface is also acceptable. It should not have two different surfaces. **Under no circumstances should the surface be concrete or asphalt.** Be sure there is room enough to maneuver, and that no other riders are close.

# PART 3

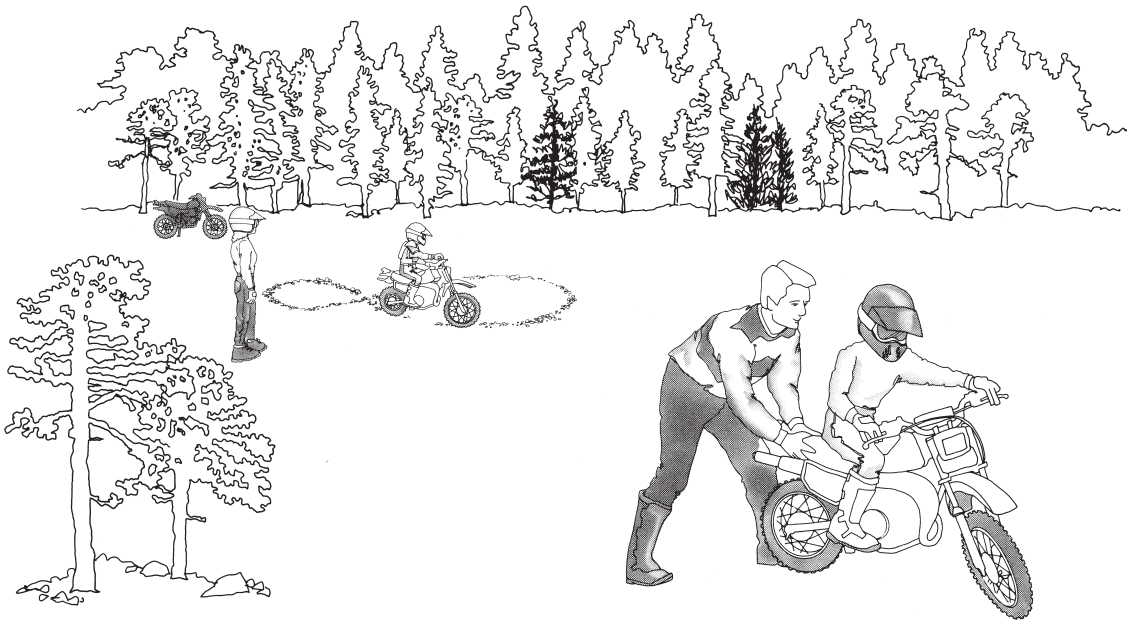



# PART 3

## Getting Used To The Vehicle In Motion

### **GETTING THE FEEL OF THE BRAKES**

Be sure your youngster is wearing all of the proper protective gear. With the engine still OFF, have your youngster mount the motorcycle. If you physically can, push the motorcycle slowly. Have your youngster brake to feel how much pressure is needed for a smooth stop. If your youngster's motorcycle has more than one brake, both should be applied with even pressure. Practice this several times until you are sure this skill is developed. Remind your youngster to keep his or her head up and look forward.

### **GETTING THE FEEL OF THE THROTTLE**

With the engine OFF, have your youngster practice smooth throttle control. Your youngster will learn how much throttle it takes to start moving in

a later exercise. Explain that opening the throttle will increase speed and that closing the throttle will decrease speed. Releasing the throttle and applying the brakes will slow the motorcycle. Ask your youngster to tell you how throttle control and braking affect the motorcycle's speed.

### **GETTING THE FEEL OF THE CLUTCH**

*(if equipped)*

With the engine OFF, have your youngster practice smooth clutch control. Have your youngster shift the motorcycle into first gear. While you push the motorcycle have the youngster slowly release the clutch lever. The point which the motorcycle stops moving indicates the clutch engagement point or "friction zone." The "friction zone" is the point at which engine power begins to be transmitted to the rear wheel. Explain that this is the point the motorcycle will start moving when the engine is running. Smooth operation will prevent stalling and

allow smooth shifting. Remind the youngster that the throttle should be closed when shifting gears. Practice this exercise several times until the skill is developed.

## **GETTING THE FEEL OF TURNING**

With the vehicle stopped and the engine OFF, have your youngster practice the proper turning technique:

1. For a right turn, look to the right and lean the motorcycle to the right.
2. For a left turn, look to the left and lean the motorcycle to the left.

Repeat this exercise with the kickstand up as you push the motorcycle. Make sure he or she can turn the vehicle in both directions using this technique while you maintain balance of the motorcycle.

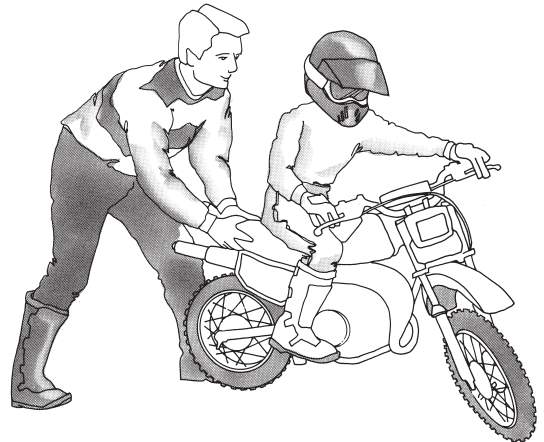

# PART 3

## BEING PREPARED FOR RIDING PRACTICE

Be sure to observe all the safety precautions covered in the Introduction and Parts 1 and 2. Double check that the riding area is free from hazards. Your youngster should wear all the proper protective gear, and the speed limiter (if equipped) should be installed and working correctly.

## STARTING THE MOTORCYCLE

Always start the motorcycle for your youngster. To remember the proper starting technique use "FINE-C."

Double check for neutral. Start the engine. Have your youngster carefully mount. Let your youngster operate the engine stop switch and shut off the motor. Re-start the engine and repeat. Allow the engine to warm up until it runs smoothly with the choke off.

<b>F</b>	FUEL VALVE	Put to "on" position.
<b>I</b>	IGNITION	Ignition on.
<b>N</b>	NEUTRAL	Motorcycle in neutral (the motorcycle rolls with the clutch lever released).
<b>E</b>	ENGINE	Stop switch in run/on start position.
<b>C</b>	CHOKE	On (for cold engine only).

# PART 3

## Let's Start Riding

Walk next to the motorcycle when your youngster first starts riding. You can also let the beginner ride back and forth between you and another adult. Help your youngster with the turns as he or she practices throttle control and braking.

### **STARTING OUT AND STOPPING**

Before your youngster moves the motorcycle under power, take a few moments to practice smooth clutch control. After shifting to first gear, have your youngster rock the motorcycle a few inches back and forth by moving the clutch in and out of the "friction zone." The clutch is not fully released while doing this. It is important that clutch operation is smooth before riding in the practice area.

The next practice session is straight-line starts and stops. Keep the riding under control.

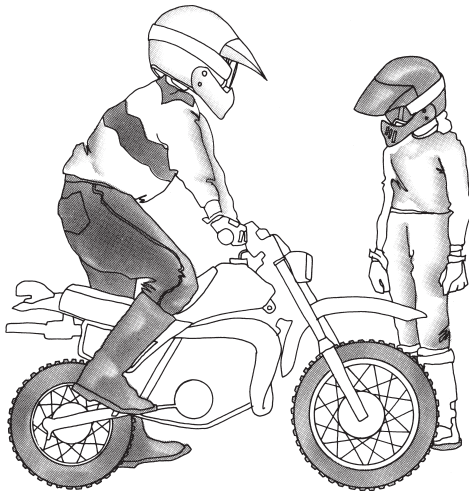

*Start the motorcycle for your youngster*

# PART 3

---

However, riding too slowly will make balance more difficult. Both brakes should be used together for smooth stops. The left foot should be placed on the ground first, keeping the right foot on the rear brake.

Be sure your youngster develops a good feel for the use of the throttle and controls. After the youngster has mastered starting and stopping at slower speeds, increase speeds by shifting.

## **TURNING**

Remind your youngster of the two steps for turning:

1. For a right turn, look to the right and lean the motorcycle to the right.
2. For a left turn, look to the left and lean the motorcycle to the left.

Have your youngster practice turning in both directions at slow speeds. Allow enough room to make a wide turn. After your youngster is skilled in making wide turns, try tighter turns.

## **Keep speed slow.**

Your youngster should master these skills at low speeds before going faster. Next, practice some figure eights. This will help your youngster make left and right turns. Make sure your youngster keeps both feet on the footpegs and looks ahead in the turns.

Once these skills are mastered, refer to the [Tips & Practice Guide for the Off-Highway Motorcyclist](#), for additional skills used in off-highway riding.

# PART 3

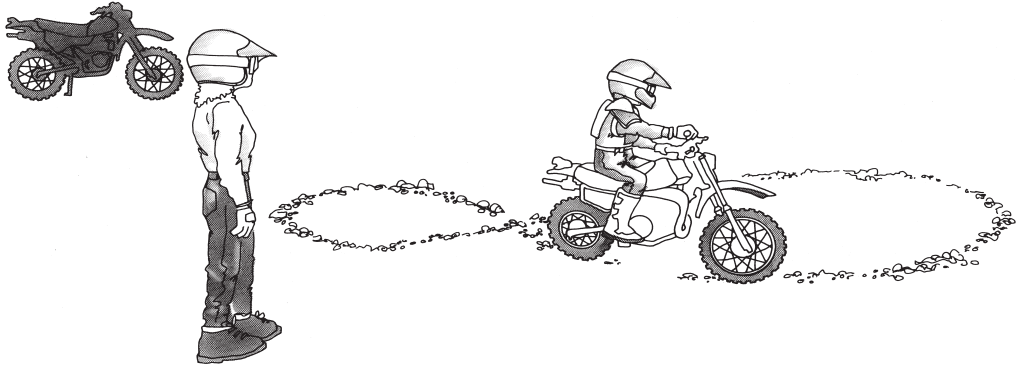

**T**his Readiness Checklist is provided to help you determine your youngster's readiness to learn to safely operate and control an OHM. There is a significant amount of judgment needed in determining a youngster's readiness to ride an OHM. The ultimate decision is the responsibility of the parent, guardian, or supervising adult. It is important that parents make informed decisions about whether or not their youngster becomes involved in off-highway motorcycle activity.

There are four developmental areas considered in the Readiness Checklist. These include: visual perception/motor development, physical development, social/emotional development, and reasoning and decision-making ability. Several questions are listed to help you determine if your youngster possesses the skills and capabilities to safely learn to operate an OHM.

The best way to utilize the Readiness Checklist is to read the particular ability, consider the answers to the questions for that ability, and check those abilities that you determine are present in your youngster. There are no suggestions as to how many abilities or the degree of ability that your youngster should possess. This Readiness Checklist may help you consider the appropriateness of OHM operation for your child. The ultimate decision for your youngster's involvement with off-highway motorcycles belongs to you, the parent.

## VISUAL PERCEPTION/MOTOR DEVELOPMENT

### **Ability**

1. Youngster can see with sufficient clarity.
2. Youngster possesses ability to perceive depth or distance.
3. Youngster has adequate side vision/ peripheral vision.
4. Youngster can judge the speed of objects.



### **Points to Evaluate**

- Can youngster see letters and numbers at least as well as you?
- Can youngster distinguish colors?
- Has youngster demonstrated adequate vision in other activities (riding bicycles, running, sports, or other recreational activities)?
- When looking at two objects in the distance, can youngster tell which is farther or closer?
- Can youngster see objects 90 degrees to each side while looking straight ahead?
- Does the youngster judge the speed of objects (fast, medium, slow) that agree with your judgments? (For example, a car on the highway, a train moving past a crossing, a dog running, people walking.)



# PART 4

## **Ability**

5. Youngster can state the distances of objects in terms of feet, yard, miles.
6. Youngster can follow movement of objects.
7. Youngster can visualize distances as displayed by a picture or photograph.
8. Youngster can follow a moving object while accomplishing hand manipulation.
9. Youngster can describe cause-and-effect experiences.



## **Points to Evaluate**

- Can youngster tell how many feet or yards it is from the house to the road?
- Can youngster tell how wide a hallway is, or the width of a room?
- Can youngster follow the path of such things as: a hit or thrown baseball, a moving car, objects in a video game?
- Can youngster estimate distance between objects in a family photograph?
- Can youngster estimate distance between objects when looking at a landscape picture?
- Can youngster dribble a basketball without looking at it?
- Can youngster manipulate video game controls while following objects on a screen?
- Can youngster describe a minor injury he or she received and correctly describe the causes?
- Can youngster describe settings or situations that can produce injury if precautions are not taken?

## **Ability**

10. Youngster can concentrate on more than one element at a time in solving a puzzle or problem.
11. Youngster can maintain relative spans of attention when given a variety of stimuli.



## **Points to Evaluate**

- Can youngster describe what may cause injury when doing such things as running, swimming, bicycling, riding in a car?
- Can youngster pick out or describe several items within a picture?
- Can youngster assemble a puzzle without unusual problems or delays?
- Can youngster describe what to do if a house fire should occur?
- Can youngster complete school homework assignments without being easily distracted?
- Can youngster assemble more difficult puzzles; for example, a nature scene or picture?

# PART 4

## PHYSICAL DEVELOPMENT

### **Ability**

1. Youngster can sit comfortably on the motorcycle and reach the controls easily.

2. Youngster has sufficient strength and familiarity to operate the controls with ease.



### **Points to Evaluate**

- Can youngster place his or her feet firmly on the footpegs?
- Do the youngster's fingers reach comfortably around the handlebars and control levers? How about with the handlebars turned? How about in different seating positions?
- Can youngster stand (with knees slightly bent) and have a few inches of space from the seat?
- Can youngster easily reach the foot controls?
- Can youngster dress with proper protective gear including putting on helmet and fastening the chin strap?

While sitting on the vehicle, can youngster:

- Squeeze the hand controls?
- Operate the shift lever (if equipped)?
- Operate the choke and fuel valve with ease?
- Press the brake lever with sufficient pressure
- Operate the controls without looking at them?

## **Ability**

3. Youngster is sufficiently coordinated.



## **Points to Evaluate**

Can youngster walk a "balance beam" (2" x 4" x 8') flat on floor?

Can youngster ride a bicycle, rollerskate or skateboard safely?

Can youngster walk on tiptoes for 10 feet?

Can youngster jump rope?

Can youngster catch a ball with hands rather than with arms?

4. Youngster has sufficient endurance to maintain strength over a period of time.

Can youngster play outdoor games without fatigue?

Can youngster participate in indoor games and sports without tiring before other youngsters?

# PART 4

## SOCIAL/EMOTIONAL DEVELOPMENT

<b>Ability</b>	✓	<b>Points to Evaluate</b>
1. Youngster can understand and follow rules.	<input type="checkbox"/>	Does youngster follow rules established at home?
	<input type="checkbox"/>	Do teachers say that the youngster follows rules?
	<input type="checkbox"/>	Does youngster listen and respond to adult supervision?
	<input type="checkbox"/>	Does youngster comprehend the importance and seriousness of having rules and regulations?
2. Youngster generally will obey parents and supervisors.	<input type="checkbox"/>	Does youngster avoid challenging authority or rebelling when rules are imposed?
3. Youngster controls behavior according to expectations?	<input type="checkbox"/>	Does youngster show evidence of self-control...doesn't get easily frustrated or upset?
	<input type="checkbox"/>	Does youngster understand consequences associated with certain actions (like not wearing a safety belt in the car)?
	<input type="checkbox"/>	Does youngster think about results before performing some action (like crossing the street, hitting or throwing a ball)?

## **Ability**

4. Youngster understands other youngsters may be permitted to do what he/she may not be allowed to.
  
5. Youngster can give reasons and/or solutions to problems seen in the environment.
  
6. Youngster can make decisions based on reality and not fantasy.



## **Points to Evaluate**

- Does youngster recognize unsafe actions of other youngsters?
- Does youngster appreciate being safer than others?
- Does youngster accept rules that are more stringent than what other youngsters have to follow?
  
- Can youngster explain how land (or grass) gets worn?
- Can youngster explain how even small damage to land can take years to recover?
- Can youngster distinguish between untouched land and used land?
  
- Can youngster complete a task in a step-by-step fashion (assemble a toy, clean a room)?
- Does youngster comprehend real injury as opposed to “cartoon” injury?
- Does youngster respond with logical solutions when asked to solve a problem?

# PART 4

## REASONING AND DECISION-MAKING ABILITY

### **Ability**

1. Youngster comprehends that interaction with others and things can result in injury.
2. Youngster has a basic understanding of what being careful means.



### **Points to Evaluate**

- Can youngster describe how and why a person received physical injury or pain?
- Does youngster notice impending accidents or potential injury-producing events, such as in sports activities or bicycle riding?
- Can youngster explain why it takes distance to stop?
- Can youngster explain how moving at even low speed can result in injury if stopped suddenly or by hitting something?
- Does youngster know why rules are established?
- Does youngster notice or recognize others being careful in action-oriented activities?
- Does youngster notice professional athletes use protective gear as part of their sport?

## **Ability**

3. Youngster understands that rules are made to reduce injury and provide long-term enjoyment.
4. Youngster has basic understanding of the physical limitations of stopping and turning.



## **Points to Evaluate**

- Can youngster explain the reason for rules at home or school?
- Does youngster understand the value of prevention? Of wearing protective gear?
- Can youngster recognize that not following rules can eliminate future fun and enjoyment?
- Can youngster explain what may happen if moving too fast while going around a curve on a bicycle? On a skateboard? On an off-highway motorcycle?



# FINAL NOTE

## TO PARENTS

---

**W**e hope this booklet has helped you and your youngster take a “safety first” approach to off-highway motorcycle riding. All off-highway motorcycle riders must use good judgment and be responsible. It is up to YOU to set a good example about motorcycle safety. You must help your youngster ride sensibly and safely at all times.

After your youngster has mastered the riding skills in this booklet and has matured to a higher level of skills, he or she may be ready to practice more advanced riding. The Motorcycle Safety Foundation’s *Tips & Practice Guide for the Off-Highway Motorcyclist* booklet provides information about riding on hills, riding across slopes, and other more advanced skills. Youngsters should have a good understanding of riding skills before using unfamiliar areas. They

should ride on flat areas, gentle hills, and gradual slopes. Be sure that your youngster rides slowly over unfamiliar terrain to locate and avoid bumps, holes, and other possible hazards. You should check the area first.

The Motorcycle Safety Foundation also recommends a video program, *The MSF DirtBike School: Learn to Ride Safely*. It demonstrates and discusses responsible riding practices.

It is also recommended that you and your youngster read the information in the owner’s manual. To find out more about rider education and off-highway motorcycle safety programs offered, or to order the video or publications, contact the **Motorcycle Safety Foundation at 2 Jenner, Suite 150, Irvine CA 92618, 949.727.3227 or visit [dirtbikeschool.com](http://dirtbikeschool.com)**

**BRAKES** - The parts of a motorcycle which allow the operator to slow down or stop the machine.

**BRAKE LEVER** - The hand brake located on the handlebar.

**BRAKE PEDAL** - The foot brake which is operated by the right foot.

**CABLES** - Heavy insulated wires. There are two kinds: mechanical and electrical. Brake cables are mechanical. The headlamp cable is electrical.

**CARBURETOR** - Device which provides the engine the proper mixture of fuel and air.

**CHOKE** - A device which enriches the mixture of gasoline and air supplied to the engine for cold engine starting.

**CLUTCH LEVER** - The hand lever used to disengage the clutch when changing gears.

**DRIVE CHAIN** - The chain which connects the engine to the rear axle to give a motorcycle motion.

**ENGINE STOP SWITCH** - Switch used to stop the engine without removing the hands from the handlebars.

**EXHAUST** - Leftover gases from the combustion process that come out of the tailpipe when the motorcycle engine is running. Exhaust contains deadly carbon monoxide gases.

**EYE PROTECTION** - Goggles or a shatter resistant shield worn over the eyes while riding to protect against dust, flying insects, or other debris. Such eye protection, when tinted, may be effective against bright sun or snow-glare conditions.

**FINE-C** - A pre-start routine. A way to remember the pre-start routine:

F - Fuel valve on

I - Ignition on

N - Neutral

E - Engine stop switch in run position

C - Choke

**FOOTPEGS** - Pivoting pegs on which a motorcycle operator should keep his/her feet while riding.

**FUEL VALVE** - A valve, usually hand operated, with an on, off and "reserve" position. Controls gasoline flow to the carburetor.

# GLOSSARY

---

**HANDLEBAR** - The metal bar attached to the front end of the motorcycle that turns the front wheel for steering. Many of the controls for the motorcycle are located on the handlebar.

**HELMET** - The most important protective clothing to be worn when operating a motorcycle. It covers the head and helps protect against skull fracture or brain injury in an accident.

**OFF-HIGHWAY or OFF-ROAD VEHICLE** - Any vehicle, including off-highway motorcycles and ATVs, which is restricted by law from operating on public roads.

**OHM** - Off-Highway Motorcycle

**PSI** - Refers to air pressure in the tires and stands for "Pounds per Square Inch."

**READING THE TERRAIN** - Looking well ahead while riding, anticipating hazards.

**SHIFT LEVER** - On those motorcycles equipped with a shift lever, it allows the operator to change gears. The shift lever is operated by the left foot.

**TAILPIPE** - That part of the exhaust system which expels waste gases.

**THROTTLE** - The control operated by the right hand which controls the engine speed.

**TRACTION** - Tread friction between the ground and the tires.

**TRANSMISSION** - Mechanism used to transmit power from the engine to the wheels.

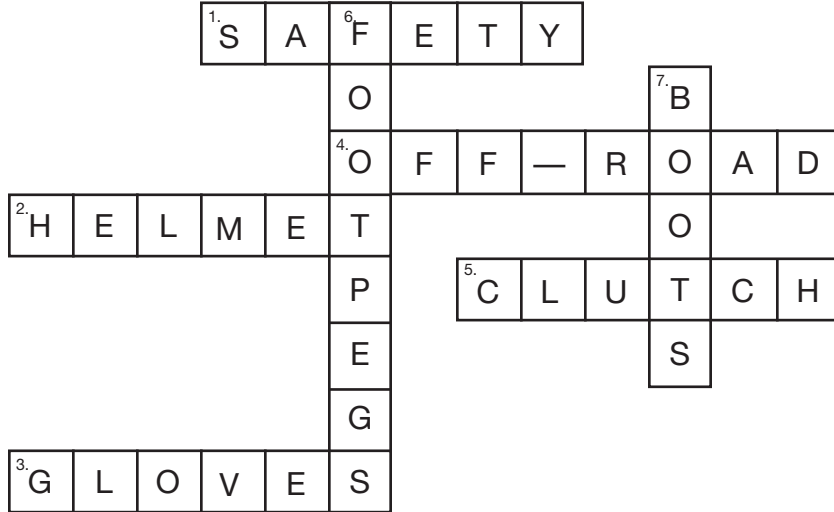

# ANSWERS

## NAME THE MOTORCYCLE PARTS (Typical)

1. Clutch lever
2. Hand brake lever
3. Foot brake lever or pedal
4. Throttle
5. Choke or enrichening device
6. Engine stop switch
7. Gas cap/tank vent
8. Starter (kick)
9. Electric starter (if equipped)

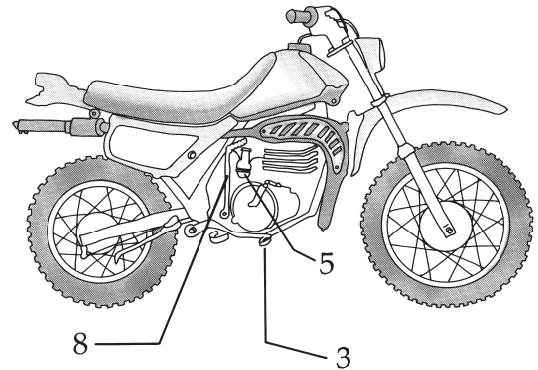
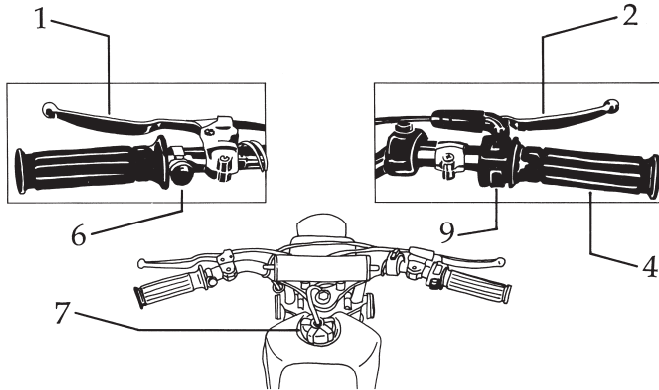

# NOTES

---

# NOTES

---







**For the rider training location nearest you,  
call: (877) 288-7093**

**[dirtbikeschool.com](http://dirtbikeschool.com)**

© 2015 Motorcycle Safety Foundation, Inc.  
2 Jenner, Suite 150 • Irvine, CA 92618  
(949) 727-3227 • [msf-usa.org](http://msf-usa.org)

PN MSPU3444NC00

<b>A</b>	
<b>Accessories</b> . . . . .	9
<b>Air filter</b>	
cleaning . . . . .	57
installing . . . . .	57
removing . . . . .	56
<b>Air filter box</b>	
cleaning . . . . .	57
<b>Air filter box cover</b>	
installing . . . . .	56
removing . . . . .	56
<b>Air suspension XACT 5543</b> . . . . .	33
<b>Antifreeze</b>	
checking . . . . .	92
<b>Auxiliary substances</b> . . . . .	9
<b>B</b>	
<b>Basic chassis setting</b>	
checking with rider's weight . . . . .	33
<b>Brake discs</b>	
checking . . . . .	72
<b>Brake fluid</b>	
of front brake, adding . . . . .	74
rear brake, adding . . . . .	79
<b>Brake fluid level</b>	
of front brake, checking . . . . .	73
rear brake, checking . . . . .	79
<b>Brake linings</b>	
front brake, changing . . . . .	75
front brake, checking . . . . .	75
of the rear brake, changing . . . . .	81
rear brake, checking . . . . .	80
<b>C</b>	
<b>Capacity</b>	
coolant . . . . .	117
fuel . . . . .	30, 117
gear oil . . . . .	106, 117
<b>Carburetor</b>	
float chamber, emptying . . . . .	102
idle setting . . . . .	100
idle speed, adjusting . . . . .	101
<b>Carburetor tuning</b> . . . . .	98
<b>Chain</b>	
checking . . . . .	65
cleaning . . . . .	62
<b>Chain guide</b>	
checking . . . . .	65
<b>Chain tension</b>	
adjusting . . . . .	64
checking . . . . .	63
<b>Choke</b> . . . . .	16
<b>Cleaning</b> . . . . .	108-109
<b>Clutch</b>	
fluid level, checking . . . . .	69
fluid level, correcting . . . . .	69
fluid, changing . . . . .	70
<b>Clutch lever</b> . . . . .	14
basic position, adjusting . . . . .	68
<b>Compression damping</b>	
fork, adjusting . . . . .	41
<b>Coolant</b>	
changing . . . . .	95
draining . . . . .	93
refilling . . . . .	94
<b>Coolant level</b>	
checking . . . . .	92-93
<b>Cooling system</b> . . . . .	90
<b>Customer service</b> . . . . .	9
<b>D</b>	
<b>Difficult operating conditions</b> . . . . .	21
dry sand . . . . .	21
high temperatures . . . . .	24
low temperature . . . . .	25
slow speed . . . . .	24
snow . . . . .	25
wet sand . . . . .	23
<b>Difficult riding conditions</b>	
muddy surfaces . . . . .	23
wet surfaces . . . . .	23
<b>E</b>	
<b>Engine</b>	
running in . . . . .	21
<b>Engine number</b> . . . . .	12
<b>Engine sprocket</b>	
checking . . . . .	65
<b>Environment</b> . . . . .	8
<b>F</b>	
<b>Figures</b> . . . . .	9
<b>Filling up</b>	
fuel . . . . .	29
<b>Foot brake lever</b> . . . . .	17
basic position, adjusting . . . . .	78
free travel, checking . . . . .	78
<b>Fork</b>	
air pressure, adjusting . . . . .	39

<b>Fork legs</b>	
basic setting, checking	39
bleeding	44
dust boots, cleaning	45
installing	46
removing	45
<b>Fork part number</b>	12
<b>Fork protector</b>	
installing	47
removing	47
<b>Frame</b>	
checking	67
<b>Front fender</b>	
installing	54
removing	54
<b>Front wheel</b>	
installing	84
removing	84
<b>Fuel tank</b>	
installing	61
removing	59
<b>Fuel tank filler cap</b>	
closing	15
opening	15
<b>Fuel tap</b>	16
<b>Fuel, oils, etc.</b>	9
<b>G</b>	
<b>Gear oil</b>	
adding	106
changing	105
<b>Gear oil level</b>	
checking	105
<b>H</b>	
<b>Hand brake lever</b>	14
free travel, adjusting	72
free travel, checking	72
<b>Handlebar position</b>	42
adjusting	42
<b>High-speed compression damping</b>	
shock absorber, adjusting	35
<b>I</b>	
<b>Ignition timing map</b>	
changing	103
plug-in connector	103
<b>Implied warranty</b>	9
<b>Intended use</b>	6
<b>K</b>	
<b>Kick starter lever</b>	17
<b>L</b>	
<b>Link fork</b>	
checking	67
<b>Lower triple clamp</b>	
installing	49
removing	48
<b>Lowspeed compression damping</b>	
shock absorber, adjusting	34
<b>M</b>	
<b>Main silencer</b>	
glass fiber yarn filling, changing	58
installing	58
removing	58
<b>Manufacturer warranty</b>	9
<b>Misuse</b>	6
<b>Motorcycle</b>	
cleaning	108
lift stand, raising with	44
removing from lift stand	44
<b>O</b>	
<b>Owner's Manual</b>	8
<b>P</b>	
<b>Play in throttle cable</b>	
adjusting	97
checking	97
<b>Plug-in stand</b>	17
<b>Preparing for use</b>	
advice on preparing for first use	19
after storage	111
checks and maintenance measures when preparing for use	26
<b>Protective clothing</b>	7
<b>R</b>	
<b>Radiator cover</b>	90
installing	90
removing	91
<b>Rear sprocket</b>	
checking	65
<b>Rear wheel</b>	
installing	86
removing	85
<b>Rebound damping</b>	
fork, adjusting	41
shock absorber, adjusting	35
<b>Riding sag</b>	
adjusting	38

<b>Rubber grip</b>			
checking	.....	68	
<b>S</b>			
<b>Safe operation</b>	.....	7	
<b>Seat</b>			
mounting	.....	55	
removing	.....	55	
<b>Service</b>	.....	9	
<b>Service hour counter</b>	.....	18	
<b>Service schedule</b>	.....	31-32	
<b>Shift lever</b>	.....	16	
basic position, adjusting	.....	103	
basic position, checking	.....	103	
<b>Shock absorber</b>			
installing	.....	55	
removing	.....	54	
riding sag, checking	.....	37	
spring preload, adjusting	.....	37	
static sag, checking	.....	36	
<b>Shock absorber article number</b>	.....	13	
<b>Spare parts</b>	.....	9	
<b>Spoke tension</b>			
checking	.....	88	
<b>Start number plate</b>			
installing	.....	53	
removing	.....	53	
<b>Starting</b>	.....	26	
<b>Steering head bearing</b>			
lubricating	.....	53	
<b>Steering head bearing play</b>			
adjusting	.....	52	
checking	.....	51	
<b>Stop button</b>	.....	14	
<b>Storage</b>	.....	110	
<b>T</b>			
<b>Technical data</b>			
capacities	.....	117	
carburetor	.....	116	
chassis	.....	117	
chassis tightening torques	.....	119	
engine	.....	114	
engine tightening torques	.....	114	
fork	.....	118	
shock absorber	.....	119	
tires	.....	118	
<b>Throttle cable routing</b>			
checking	.....	67	
<b>Throttle grip</b>	.....	14	
<b>Tire condition</b>			
checking	.....	87	
<b>Tire pressure</b>			
checking	.....	88	
<b>Transporting</b>	.....	29	
<b>Troubleshooting</b>	.....	112-113	
<b>Type label</b>	.....	12	
<b>U</b>			
<b>Use definition</b>	.....	6	
<b>V</b>			
<b>Vehicle identification number</b>	.....	12	
<b>View of vehicle</b>			
front left	.....	10	
rear right	.....	11	
<b>W</b>			
<b>Work rules</b>	.....	8	



3214408en

02/2022

