

## FREERIDE E-XC

Art. no. 3214428en





Congratulations on your decision to purchase a KTM motorcycle. You are now the owner of a state-of-the-art sports vehicle which, with appropriate care, will bring you pleasure for a long time to come.

We wish you good and safe riding at all times!

Enter the serial numbers of your vehicle below.

Vehicle identification number (📖 p. 17)	Dealer's stamp
Motor number (📖 p. 17)	
Key number (📖 p. 17)	

Please read through this Owner's Manual carefully, exercise caution when using the vehicle, and contact an authorized KTM workshop if you have any questions. This Owner's Manual serves as a technical instruction manual, explains important safety matters, and provides an overview of the main functions. This Owner's Manual is only intended for personal use. This Owner's Manual is not intended for commercial use. The Owner's Manual contained the latest information for this model series at the time of publication. Slight deviations resulting from continuing development and design of the motorcycles cannot, however, be completely excluded.

All specifications contained herein are non-binding. KTM Sportmotorcycle GmbH specifically reserves the right to modify or delete technical specifications, prices, colors, forms, materials, services, designs, equipment, etc., without prior notice and without specifying reasons, to adapt these to local conditions, as well as to stop production of a particular model without prior notice. KTM accepts no liability for delivery options, deviations from figures and descriptions, misprints, and other errors. The models portrayed partly contain special equipment that does not belong to the regular scope of supply.

© 2021 KTM Sportmotorcycle GmbH, Mattighofen Austria

All rights reserved

Reproduction, even in part, as well as copying of all kinds, is permitted only with the express written permission of the copyright owner.



ISO 9001(12 100 6061)

KTM applies quality assurance processes that lead to the highest possible product quality as defined in the ISO 9001 international quality management standard.

Issued by: TÜV Management Service

REG.NO. 12 100 6061

KTM Sportmotorcycle GmbH  
Stallhofnerstraße 3  
5230 Mattighofen, Austria

This document is valid for the following models:

FREERIDE E-XC EU (F3001V1)



3214428en

02/2021

# TABLE OF CONTENTS

1	MEANS OF REPRESENTATION .....	5	6.7	Light switch .....	20
1.1	Symbols used .....	5	6.8	Turn signal switch.....	21
1.2	Formats used.....	5	6.9	Side stand.....	21
2	SAFETY ADVICE.....	6	6.10	Ignition lock .....	21
2.1	Use definition – intended use.....	6	6.11	Steering lock .....	22
2.2	Misuse.....	6	6.12	Locking the steering.....	22
2.3	Safety advice.....	6	6.13	Unlocking the steering.....	22
2.4	Degrees of risk and symbols.....	6	7	DISPLAY .....	23
2.5	Safety instructions and warning labels .....	7	7.1	Multifunctional element.....	23
2.6	Tampering warning.....	10	7.1.1	Multifunctional element .....	23
2.7	Safe operation .....	10	7.1.2	Riding mode button .....	23
2.8	Fall or accident.....	10	7.1.3	Driving mode display.....	24
2.9	Protective clothing .....	11	7.1.4	Malfunction indicator lamp.....	24
2.10	Work on the vehicle, motor, and lithium-ion battery (Powerpack HV)....	11	7.1.5	Charge level indicator.....	24
2.11	Environment.....	11	7.1.6	Power reduction.....	25
2.12	Owner's Manual .....	12	7.2	Overview .....	26
2.13	Fire hazard.....	12	7.2.1	Overview of indicator lamps .....	26
3	IMPORTANT NOTES.....	13	8	COMBINATION INSTRUMENT .....	27
3.1	Manufacturer warranty, implied warranty.....	13	8.1	Combination instrument overview .....	27
3.2	Fuel, auxiliary substances.....	13	8.2	Activation and test .....	27
3.3	Spare parts, accessories .....	13	8.3	Setting the kilometers or miles .....	27
3.4	Service .....	13	8.4	Setting the combination instrument ...	28
3.5	Figures .....	13	8.5	Setting the clock.....	29
3.6	Customer service.....	13	8.6	Viewing the lap time.....	29
3.7	Power supply.....	14	8.7	Display mode SPEED (speed).....	30
3.8	New Powerpack HV .....	14	8.8	Display mode SPEED/H (operating hours) .....	30
3.9	Operation at low temperatures.....	14	8.9	Setup menu .....	30
4	VIEW OF VEHICLE .....	15	8.10	Adjusting the unit of measurement ...	31
4.1	View of vehicle, front left (example) ...	15	8.11	Display mode SPEED/CLK (time) .....	32
4.2	View of vehicle, rear right (example).....	16	8.12	Setting the clock.....	32
5	SERIAL NUMBERS .....	17	8.13	Display mode SPEED/LAP (lap time) .....	32
5.1	Vehicle identification number.....	17	8.14	Viewing the lap time.....	33
5.2	Type label .....	17	8.15	Display mode SPEED/ODO (odometer) .....	33
5.3	Key number.....	17	8.16	Display mode SPEED/TR1 (trip master 1) .....	34
5.4	Motor number.....	17	8.17	Display mode SPEED/TR2 (trip master 2) .....	34
5.5	Fork part number .....	18	8.18	Adjusting TR2 (trip master 2).....	34
5.6	Shock absorber article number .....	18	8.19	Display mode SPEED/A1 (average speed 1) .....	35
5.7	Battery identification number.....	18	8.20	Display mode SPEED/A2 (average speed 2) .....	35
6	CONTROLS.....	19	8.21	Display mode SPEED/S1 (stop watch 1) .....	36
6.1	Front brake lever.....	19	8.22	Display mode SPEED/S2 (stop watch 2) .....	36
6.2	Rear brake lever.....	19	8.23	Table of functions.....	37
6.3	Throttle grip .....	19	8.24	Table of conditions and menu activation .....	38
6.4	Main switch.....	19			
6.5	Start button.....	20			
6.6	Horn button.....	20			

9	PREPARING FOR USE.....	39	13.3	Bleeding the fork legs.....	58
9.1	Advice on preparing for first use .....	39	13.4	Removing the fork protector .....	58
10	RIDING INSTRUCTIONS.....	40	13.5	Installing the fork protector.....	59
10.1	Checks and maintenance measures when preparing for use .....	40	13.6	Cleaning the dust boots of the fork legs .....	59
10.2	Starting the vehicle .....	40	13.7	Removing the fork legs 🛠.....	60
10.3	Starting off.....	42	13.8	Installing the fork legs 🛠.....	61
10.4	Recuperation .....	42	13.9	Removing the lower triple clamp 🛠.....	61
10.5	Braking.....	42	13.10	Installing the lower triple clamp 🛠.....	62
10.6	Stopping, parking.....	43	13.11	Checking steering head bearing play 🛠.....	64
10.7	Deactivating the vehicle.....	43	13.12	Adjusting steering head bearing play 🛠.....	65
10.8	Transporting the vehicle .....	44	13.13	Greasing the steering head bearing 🛠.....	66
10.9	Transporting Powerpack HV .....	44	13.14	Removing front fender.....	66
11	SERVICE SCHEDULE .....	45	13.15	Installing front fender.....	67
11.1	Additional information.....	45	13.16	Removing the shock absorber 🛠.....	68
11.2	Required work .....	45	13.17	Installing the shock absorber 🛠.....	68
11.3	Recommended work.....	46	13.18	Folding the seat up .....	69
12	TUNING THE CHASSIS .....	47	13.19	Locking the seat .....	69
12.1	Checking the basic chassis setting with the rider's weight .....	47	13.20	Removing the spoiler.....	69
12.2	Compression damping of the shock absorber.....	47	13.21	Installing the spoiler.....	70
12.3	Adjusting the low-speed compression damping of the shock absorber.....	47	13.22	Mounting the protection cap .....	71
12.4	Adjusting the high-speed compression damping of the shock absorber 🛠.....	48	13.23	Removing the protection cap.....	71
12.5	Adjusting the rebound damping of the shock absorber .....	49	13.24	Checking the battery discharge plug form ring.....	71
12.6	Measuring the rear wheel dimension unloaded.....	50	13.25	Checking for chain dirt accumulation.....	72
12.7	Checking the static sag of the shock absorber.....	51	13.26	Cleaning the chain .....	72
12.8	Checking the riding sag of the shock absorber.....	51	13.27	Checking the chain tension .....	73
12.9	Adjusting the spring preload of the shock absorber 🛠.....	52	13.28	Adjusting the chain tension 🛠.....	74
12.10	Adjusting the riding sag 🛠.....	53	13.29	Checking the chain, rear sprocket, engine sprocket, and chain guide .....	75
12.11	Checking the basic setting of the fork .....	53	13.30	Checking the frame 🛠.....	77
12.12	Adjusting the compression damping of the fork .....	54	13.31	Checking the link fork 🛠.....	77
12.13	Adjusting the rebound damping of the fork.....	54	13.32	Checking the rubber grip .....	78
12.14	Handlebar position .....	55	14	BRAKE SYSTEM .....	79
12.15	Adjusting the handlebar position 🛠.....	56	14.1	Checking the free travel of the front brake lever .....	79
13	SERVICE WORK ON THE CHASSIS.....	57	14.2	Adjusting the free travel of the front brake lever .....	79
13.1	Raising the motorcycle with a lift stand.....	57	14.3	Checking the brake discs .....	79
13.2	Removing the motorcycle from the lift stand .....	57	14.4	Checking the front brake fluid level ...	80
			14.5	Adding front brake fluid 🛠.....	81
			14.6	Checking the front brake linings.....	82
			14.7	Changing the brake linings of the front brake 🛠.....	83
			14.8	Checking the free travel of the rear brake lever .....	85
			14.9	Adjusting the free travel of the rear brake lever .....	86
			14.10	Checking the rear brake fluid level.....	86
			14.11	Adding rear brake fluid 🛠.....	86









# TABLE OF CONTENTS

14.12	Checking the rear brake linings .....	88	18.6	Changing the coolant.....	125
14.13	Changing the rear brake linings 🛠.....	88	19	TUNING THE ENGINE.....	127
15	WHEELS, TIRES .....	91	19.1	Selecting the riding mode.....	127
15.1	Removing the front wheel 🛠.....	91	20	SERVICE WORK ON THE ENGINE .....	128
15.2	Installing the front wheel 🛠.....	91	20.1	Changing the gear oil 🛠.....	128
15.3	Removing the rear wheel 🛠.....	92	21	CLEANING, CARE .....	130
15.4	Installing the rear wheel 🛠.....	93	21.1	Cleaning the motorcycle .....	130
15.5	Checking the tire condition .....	95	21.2	Checks and maintenance steps for winter operation.....	131
15.6	Checking tire pressure.....	95	22	STORAGE.....	132
15.7	Checking the spoke tension.....	96	22.1	Storage .....	132
16	ELECTRICAL SYSTEM .....	98	22.2	Preparing for use after storage.....	133
16.1	Removing the 12-V battery 🛠.....	98	23	TROUBLESHOOTING .....	134
16.2	Installing the 12-V battery 🛠.....	98	23.1	Vehicle troubleshooting .....	134
16.3	Charging the 12-V battery 🛠.....	99	23.2	Troubleshooting of the battery charger .....	136
16.4	Changing the fuses of individual electrical power consumers .....	100	23.3	Troubleshooting Powerpack HV on the battery charger.....	137
16.5	Removing the headlight mask with the headlight.....	102	24	TECHNICAL DATA.....	138
16.6	Installing the headlight mask with the headlight.....	102	24.1	Engine .....	138
16.7	Changing the headlight bulb .....	103	24.2	Engine tightening torques .....	138
16.8	Changing the turn signal bulb .....	104	24.3	Capacities .....	138
16.9	Checking the headlight setting .....	105	24.3.1	Gear oil.....	138
16.10	Adjusting the headlight range.....	105	24.3.2	Coolant.....	138
16.11	Changing the combination instrument battery.....	106	24.4	Chassis .....	138
16.12	Diagnostic connection .....	107	24.5	Electrical system.....	139
17	POWERPACK HV, BATTERY CHARGER.....	108	24.6	Tires.....	140
17.1	Removing the Powerpack HV.....	108	24.7	Fork.....	140
17.2	Installing the Powerpack HV .....	109	24.8	Shock absorber .....	140
17.3	Overview of the battery charger for the Powerpack HV (Option: Battery charger 1) .....	110	24.9	Chassis tightening torques .....	141
17.4	Overview of the battery charger for the Powerpack HV (Option: Battery charger 2) .....	111	25	SUBSTANCES .....	143
17.5	Positioning the battery charger.....	111	26	AUXILIARY SUBSTANCES .....	145
17.6	Checking residual current protection switch (Option: Battery charger 1) .....	113	27	STANDARDS .....	146
17.7	Charging the Powerpack HV .....	113	28	INDEX OF SPECIAL TERMS .....	147
17.8	Charging the Powerpack HV in charging mode Storage .....	117	29	LIST OF ABBREVIATIONS.....	148
17.9	Changing charging socket protection cap 🛠.....	120	30	LIST OF SYMBOLS.....	149
18	COOLING SYSTEM .....	121	30.1	Yellow and orange symbols.....	149
18.1	Cooling system .....	121	30.2	Green and blue symbols.....	149
18.2	Checking the antifreeze and coolant level.....	121	INDEX.....		151
18.3	Checking the coolant level .....	122			
18.4	Draining the coolant 🛠.....	123			
18.5	Refilling with coolant 🛠.....	124			

## 1.1 Symbols used

The meaning of specific symbols is described below.

---

	Indicates an expected reaction (e.g. of a work step or a function).
	Indicates an unexpected reaction (e.g. of a work step or a function).
	All work marked with this symbol requires specialist knowledge and technical understanding. In the interest of your own safety, have these jobs performed by an authorized KTM workshop! Your motorcycle will be optimally cared for there by specially trained experts using the auxiliary tools required.
	Indicates a page reference (more information is provided on the specified page).
	Indicates information with more details or tips.
	Indicates the result of a testing step.
	Indicates a voltage measurement.
	Indicates a current measurement.
	Indicates the end of an activity, including potential rework.

---

## 1.2 Formats used

The typographical formats used in this document are explained below.

---

<b>Proprietary name</b>	Indicates a proprietary name.
<b>Name<sup>®</sup></b>	Indicates a protected name.
<b>Brand<sup>™</sup></b>	Indicates a brand available on the open market.
<b><u>Underlined terms</u></b>	Refer to technical details of the vehicle or indicate technical terms, which are explained in the glossary.

---

### 2.1 Use definition – intended use

This vehicle has been designed and built to withstand the normal stresses and strains of offroad use.



#### Info

This vehicle is only authorized for operation on public roads in its homologated version. Only use the lithium-ion battery while it is inside the vehicle.

### 2.2 Misuse

The vehicle must only be used as intended.

Dangers can arise for people, property and the environment through use not as intended.

Any use of the vehicle beyond the intended and defined use constitutes misuse.

Misuse also includes the use of operating and auxiliary fluids which do not meet the required specification for the respective use.

### 2.3 Safety advice

A number of safety instructions need to be followed to operate the product described safely. Therefore read this instruction and all further instructions included carefully. The safety instructions are highlighted in the text and are referred to at the relevant passages.



#### Info

Various information and warning labels are attached in prominent locations on the product described. Do not remove any information or warning labels. If they are missing, you or others may not recognize dangers and may therefore be injured.

### 2.4 Degrees of risk and symbols



#### Danger

Identifies a danger that will immediately and invariably lead to fatal or serious permanent injury if the appropriate measures are not taken.



#### Warning

Identifies a danger that is likely to lead to fatal or serious injury if the appropriate measures are not taken.



#### Caution

Identifies a danger that may lead to minor injuries if the appropriate measures are not taken.

#### Note

Identifies a danger that will lead to considerable machine and material damage if the appropriate measures are not taken.



#### Note

Indicates a danger that will lead to environmental damage if the appropriate measures are not taken.



## 2.5 Safety instructions and warning labels

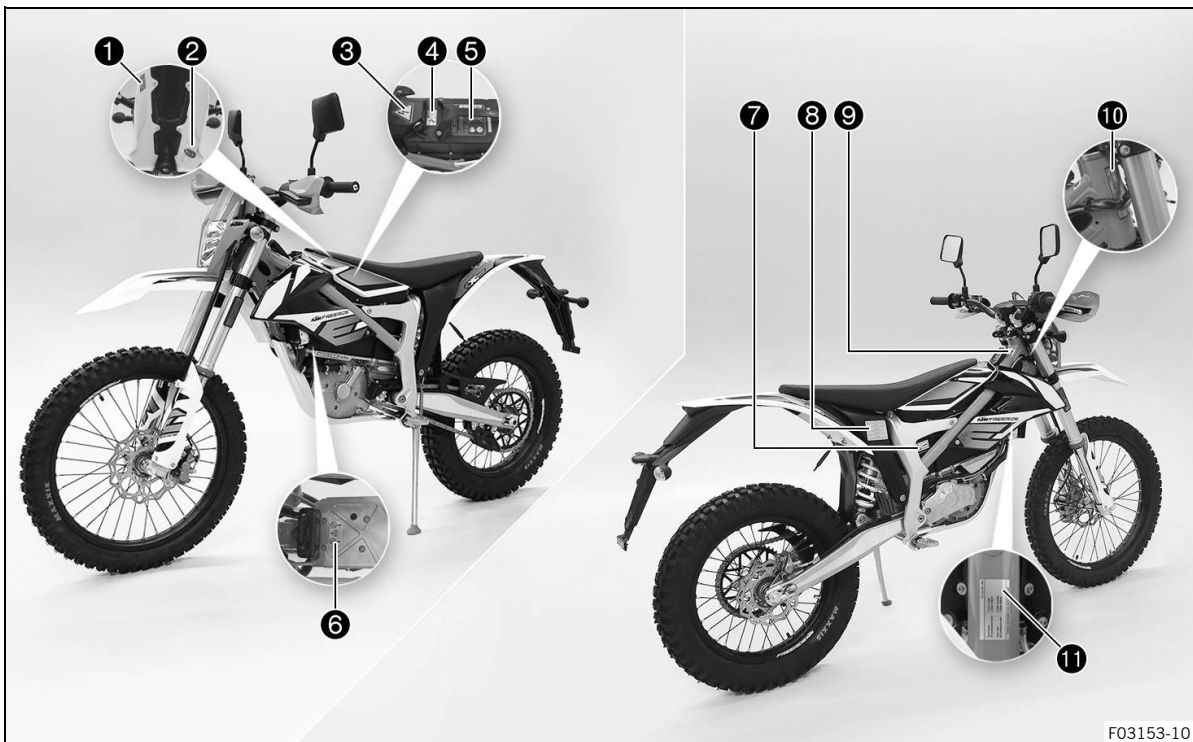

F03153-10

### **i** Info

The safety instructions are highlighted in the text. The vehicle has warning labels in prominent locations. Do not remove any warning labels, or else you or others may fail to recognize sources of danger and become injured.

1	Chain tension
2	Multifunctional element
3	High-voltage components
4	High-voltage components and electric shock
5	Rechargeable lithium-ion battery
6	High-voltage components and electric shock
7	High-voltage components, see the Repair Manual
8	Initial start-up
9	High-voltage components and electric shock, see the Owner's Manual
10	Type label for EU
11	Technical information

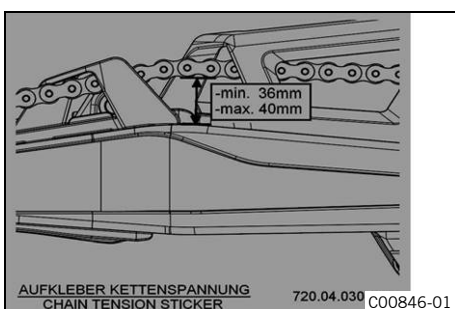

Chain tension

## 2 SAFETY ADVICE

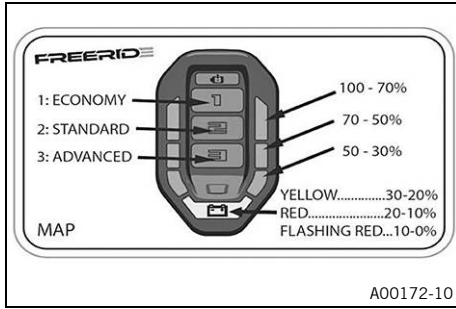

Multifunctional element

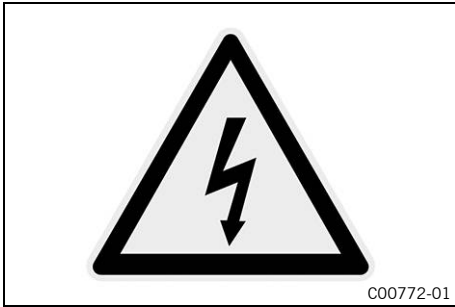

High-voltage components



High-voltage components and electric shock

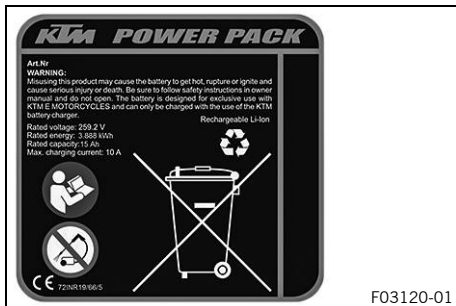

Rechargeable lithium-ion battery

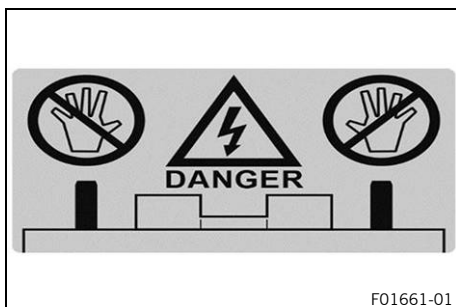

High-voltage components and electric shock

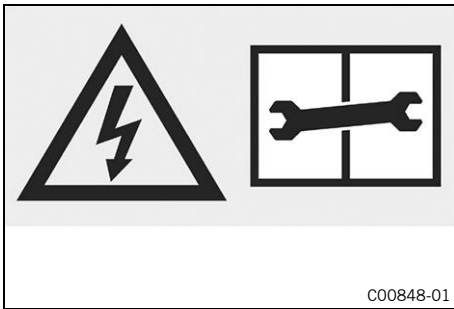

High-voltage components, see the Repair Manual

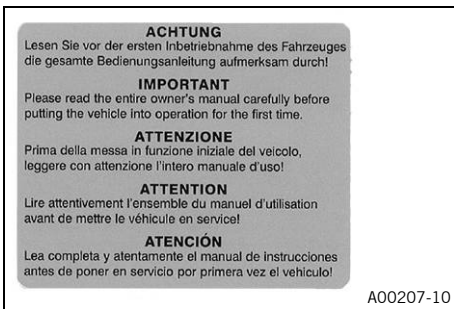

Initial start-up

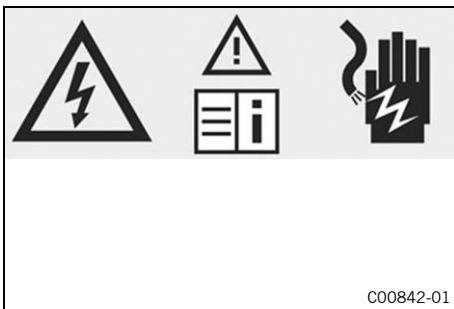

High-voltage components and electric shock, see the Owner's Manual

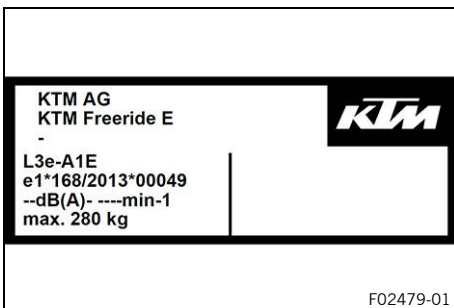

Type label for EU

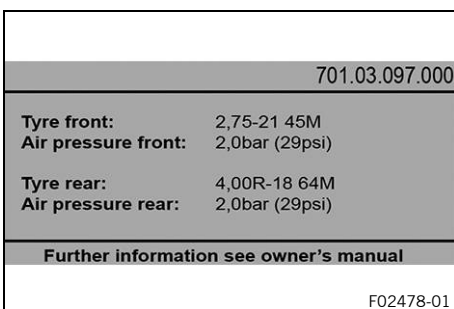

Technical information

### 2.6 Tampering warning

Modifying the vehicle is prohibited, as otherwise safe operation cannot be guaranteed.

Examples of unlawful manipulation and modifications:

- 1 Opening the rechargeable lithium-ion battery (Powerpack HV) or the motor.
- 2 Using the vehicle or the rechargeable lithium-ion battery (Powerpack HV) when proper maintenance has not been performed.
- 3 Using the vehicle or the rechargeable lithium-ion battery (Powerpack HV) outside of its defined use.
- 4 Using a damaged lithium-ion battery (Powerpack HV).

### 2.7 Safe operation



#### **Danger**

**Danger of accidents** A rider who is not fit to ride poses a danger to him or herself and others.

- Do not operate the vehicle if you are not fit to ride due to alcohol, drugs or medication.
- Do not operate the vehicle if you are physically or mentally impaired.



#### **Warning**

**Danger of burns** Some vehicle components become very hot when the vehicle is operated.

- Do not touch any parts such as the radiator, motor, shock absorber, or brake system before these parts have cooled down.
- Let the vehicle parts cool down before you perform any work on the vehicle.

This vehicle is a high voltage electric motorcycle. For this reason, follow the safety and care instructions that apply when using an electric motor.

In drive modes in which recuperation is not possible, the vehicle handles similarly to a bicycle with a freewheel. When the throttle grip is closed, the vehicle continues rolling without significant deceleration. The vehicle speed decreases on account of rolling resistance and air resistance.

The rear brake lever is located on the left side of the handlebar. Because this vehicle does not have a manual transmission, there is no clutch.

As with all liquid-cooled vehicles, the operating temperature rises according to use, ambient temperature and cleanliness of the cooling surfaces. If the temperature of the engine, the lithium-ion battery, or the electronics rises above the permissible operating temperature, the power of the vehicle is reduced markedly. This protects the system against damage from overheating. When power reduction is imminent, the active driving mode indicator flashes. When power reduction is active, all three driving mode indicators light up. When all components have returned to their normal operating temperature, full system power is restored after restarting.

Only operate the vehicle when it is in perfect technical condition, in accordance with its intended use, and in a safe and environmentally compatible manner.

Have malfunctions that impair safety promptly eliminated by an authorized KTM workshop.

Adhere to the information and warning labels on the vehicle.

### 2.8 Fall or accident



#### **Warning**

**Risk of injury** The outside of a damaged vehicle may be conducting live current.

- Contact the KTM customer service immediately if major damage has occurred to the rechargeable lithium-ion battery (Powerpack HV) or to the motor.

If the vehicle is lying on its side, it switches from ready mode to standby mode after seven seconds. To switch the vehicle back into ready mode, place it in an upright position and press the start button.

After a fall or accident, check the vehicle as usual when preparing for use.

## 2.9 Protective clothing



### Warning

**Risk of injury** Missing or poor protective clothing presents an increased safety risk.

- Wear appropriate protective clothing such as helmet, boots, gloves as well as trousers and a jacket with protectors on all rides.
- Always wear protective clothing that is in good condition and meets the legal regulations.

## 2.10 Work on the vehicle, motor, and lithium-ion battery (Powerpack HV)



### Warning

**Risk of injury** There is a risk of electric shock when working on high-voltage components.

Work on high-voltage components requires special training, qualifications and tools.

- Have all work that is not described and explained performed by trained KTM mechanics only.
- Do not open the electric motor or the lithium-ion battery (Powerpack HV).



### Warning

**Risk of injury** The vehicle runs very quietly, even when it is ready to operate.

The vehicle starts moving in an uncontrolled manner if the throttle grip is accidentally touched while work is being performed on the vehicle.

The high-voltage components of the vehicle are only deactivated if the vehicle is switched off at the main switch.

- Ensure that the vehicle is switched off at the main switch and remains switched off while any work is being performed on the vehicle.
- Remove the PowerPack HV from the vehicle before you start any work on the vehicle.
- Secure the vehicle against access by unauthorized persons while you are performing work on the vehicle.

## 2.11 Environment

When you respect the rights of others and use your motorcycle legally, you will help protect the future of motorcycle sport and avoid most conflicts and problems.

When disposing of used oil, other operating and auxiliary fluids, and used components, comply with the applicable laws and regulations in your country.

When disposing of the lithium-ion battery (Powerpack HV) and the 12-V battery, comply with the applicable laws and regulations in your country.

Your authorized KTM dealer can dispose of the Powerpack HV free of charge and in an environmentally compatible manner.

Because motorcycles are not subject to the EU regulations governing the disposal of used vehicles, there are no legal regulations that pertain to the disposal of an end-of-life motorcycle. Your authorized KTM dealer will be glad to assist you.

Electrical devices like the battery charger may not be disposed of with household waste. Electrical devices must be disposed of through the appropriate recycling centers. Contact your municipality or your authorized KTM dealer.

### 2.12 Owner's Manual

Read this owner's manual carefully and completely before making your first trip. The Owner's Manual contains useful information and many tips on how to operate, handle, and service your motorcycle. This is the only way to find out how best to customize the vehicle for your own use and how you can protect yourself from injury.



#### Tip

Store the Owner's Manual on your terminal device, for example, so that you can read it whenever you need to.

If you would like to know more about the vehicle or have questions on the material you read, please contact an authorized KTM dealer.

The Owner's Manual is an important component of the vehicle. If the vehicle is sold, the Owner's Manual must be downloaded again by the new owner.

The Owner's Manual can be downloaded several times using the QR code or the link on the delivery certificate.

The Owner's Manual is also available for download from your authorized KTM dealer and on the KTM website. A printed copy can also be ordered from your authorized KTM dealer.

International KTM Website: [KTM.com](http://KTM.com)

### 2.13 Fire hazard



#### Warning

**Fire hazard** Damaged rechargeable lithium-ion batteries present a fire hazard.

Massive mechanical damage may cause an internal cell short circuit and then cause the battery to self-ignite.

- Contact KTM customer service immediately if major damage to the rechargeable lithium-ion battery has occurred.

There is no particular fire hazard for this vehicle when the rechargeable lithium-ion battery (Powerpack HV) is intact.

However, should the vehicle catch fire, inform the fire department responsible that an electric vehicle with a rechargeable lithium-ion battery is on fire.

**3.1 Manufacturer warranty, implied warranty**

The work prescribed in the service schedule must only be carried out in an authorized KTM workshop and confirmed in the **KTM Dealer.net**, as otherwise all warranty claims will be void. Damage or secondary damage caused by tampering with and/or conversions on the vehicle are not covered by the manufacturer warranty.

**3.2 Fuel, auxiliary substances**

Use the operating and auxiliary substances (such as oils and lubricants) specified in the Owner's Manual.

**3.3 Spare parts, accessories**

For your own safety, only use spare parts and accessory products that are approved and/or recommended by KTM and have them installed by an authorized KTM workshop. KTM accepts no liability for other products and any resulting damage or loss.

Certain spare parts and accessory products are specified in parentheses in the descriptions. Your authorized KTM dealer will be glad to advise you.

The current **KTM PowerParts** for your vehicle can be found on the KTM website.  
International KTM Website: [KTM.com](http://KTM.com)

**3.4 Service**

A prerequisite for perfect operation and prevention of premature wear is that the service, care, and tuning work is properly carried out as described in the Owner's Manual. An incorrect suspension setting can lead to damage and breakage of chassis components.

Use of the vehicle under difficult conditions, such as on sand or on wet and muddy surfaces, can result in significantly increased wear of components, such as the drive train, brake system, or suspension components. For this reason, it may be necessary to inspect or replace parts before the next scheduled service.

It is imperative that you adhere to the stipulated service intervals. If you observe these exactly, you will ensure a much longer service life for your motorcycle.

The relevant mileage or time interval is whichever occurs first.

**3.5 Figures**

The figures contained in the manual may depict special equipment.

In the interest of clarity, some components may be shown disassembled or may not be shown at all. It is not always necessary to disassemble the component to perform the activity in question. Please follow the instructions in the text.

**3.6 Customer service**

Your authorized KTM dealer will be happy to answer any questions you may have on your vehicle and KTM.

A list of authorized KTM dealers can be found on the KTM website.  
International KTM Website: [KTM.com](http://KTM.com)

## 3 IMPORTANT NOTES

### 3.7 Power supply



F03119-10

A rechargeable lithium-ion battery **1** (Powerpack HV, 260 V) and a 12-V battery **2** are installed in the vehicle. The 12-V battery is located at the rear, under the seat. The fuse box **3** is located next to the 12-V battery. The Powerpack HV is located under the seat and is screwed onto the electric motor. The Powerpack HV can be removed in a few easy steps.

The Powerpack HV can be charged while it is installed in the vehicle or outside the vehicle.

Check the Powerpack HV for damage to the housing or connector every time it is removed and reinstalled.

The 12-V battery is necessary to operate the vehicle. The vehicle control unit requires the 12-V battery to start the system. If the 12-V battery is faulty, discharged, or disconnected, the vehicle will not start.

### 3.8 New Powerpack HV

When using the Powerpack HV for the first time, the vehicle must be ridden until the Powerpack HV is completely discharged. The vehicle will initially reduce its output power. When operating in power-reduced mode, the vehicle can still be driven for a few more minutes before the vehicle switches off with blink code 11.

Now charge the Powerpack HV until the battery charger completes the process at 100%. The charge level indicator on the battery charger shows the progress made.

This charging process generally takes approximately 135 minutes, but may take up to four hours. Do not skip this procedure as it has a significant influence on the performance of the Powerpack HV.

### 3.9 Operation at low temperatures

In order to protect the Powerpack HV, the motor control reduces the power at low temperatures.

When the temperature of the Powerpack HV drops to below 9 °C, the motor control unit reduces the power to 80%. Below 0 °C, 50% of power remains available. In both cases, the active riding mode indicator flashes slowly. The vehicle can continue to be operated. The Powerpack HV is not damaged by the power reduction.

The Powerpack HV heats up when the vehicle is in operation. When the temperature of the Powerpack HV rises above 0 °C, power is restored to 80% after the vehicle is restarted. When the temperature of the Powerpack HV rises above 8 °C, full vehicle power is restored after the vehicle is restarted.



**4.1 View of vehicle, front left (example)**

- ❶ Front brake lever (📖 p. 19)
- ❷ Rear brake lever (📖 p. 19)
- ❸ Seat release
- ❹ Shock absorber compression adjuster
- ❺ Shock absorber rebound adjuster
- ❻ Side stand (📖 p. 21)
- ❼ Steering lock (📖 p. 22)

## 4.2 View of vehicle, rear right (example)

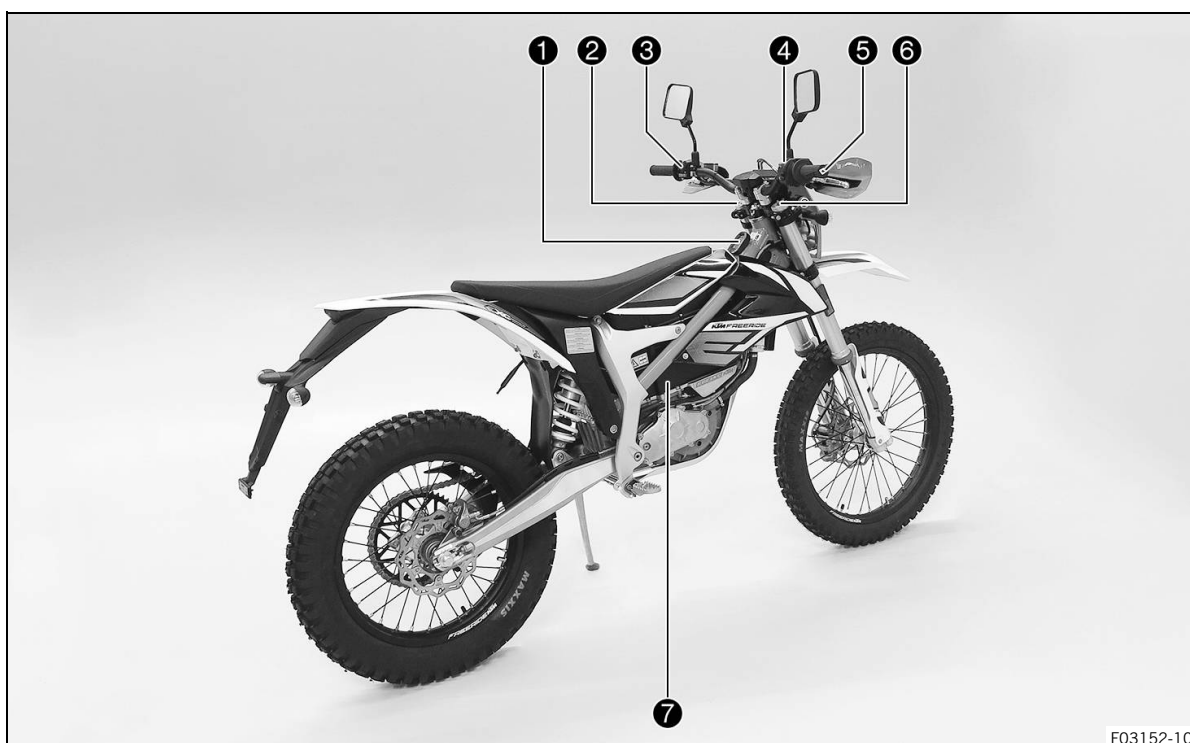

F03152-10

- ❶ Multifunction element (📖 p. 23)
- ❷ Fork compression adjuster
- ❸ Horn button (📖 p. 20)
- ❹ Light switch (📖 p. 20)
- ❺ Turn signal switch (📖 p. 21)
- ❻ Main switch (📖 p. 19)
- ❼ Start button (📖 p. 20)
- ❽ Throttle grip (📖 p. 19)
- ❾ Fork rebound adjustment
- ❿ PowerPack HV

## 5.1 Vehicle identification number

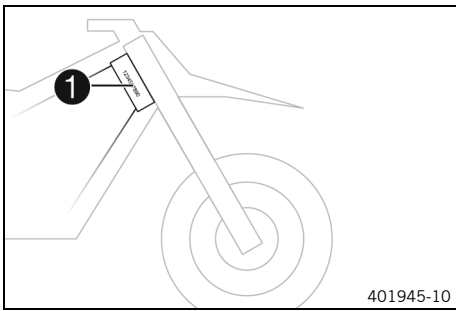

The vehicle identification number **1** is stamped on the right side of the steering head.

## 5.2 Type label

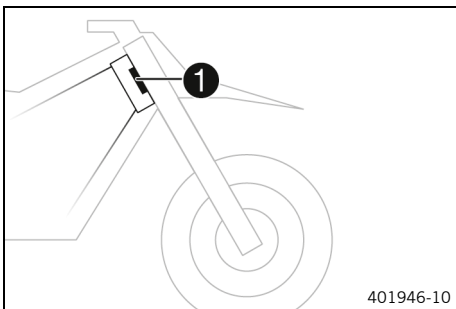

The type label **1** is located on the front steering head.

## 5.3 Key number

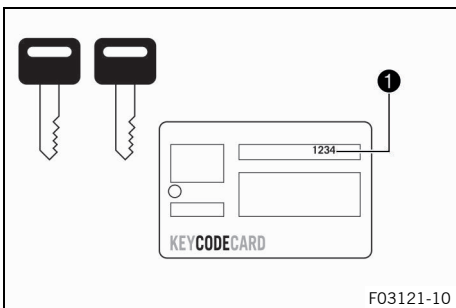

The key number **1** can be found on the **KEYCODECARD**.



### Info

You need the key number to order a spare key. Keep the **KEYCODECARD** in a safe place.

## 5.4 Motor number

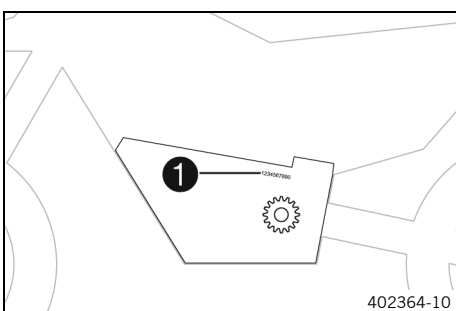

The motor number **1** is located on the left side of the motor over the motor sprocket.

# 5 SERIAL NUMBERS

## 5.5 Fork part number

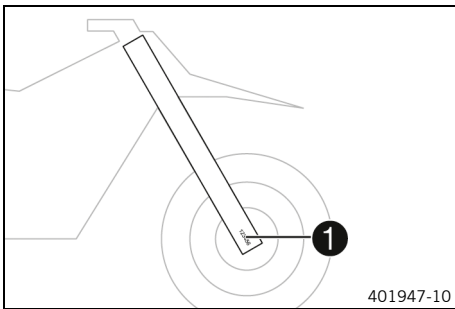

The fork part number **1** is stamped on the inner side of the axle clamp.

## 5.6 Shock absorber article number

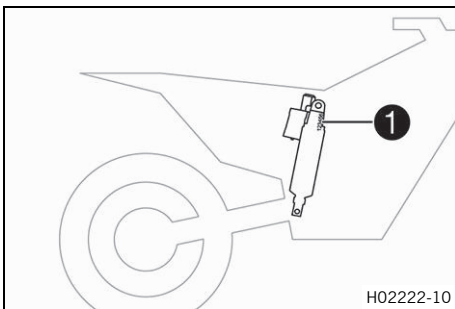

Shock absorber article number **1** is stamped on the top of the shock absorber above the adjusting ring towards the motor side.

## 5.7 Battery identification number



The battery identification number (**BIN**) **1** is stamped under the handle of the Powerpack HV.

**6.1 Front brake lever**

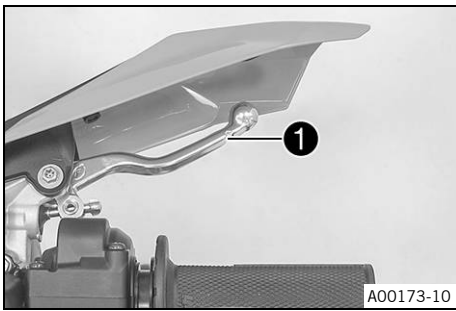

Front brake lever ① is fitted on the right side of the handlebar.

**6.2 Rear brake lever**

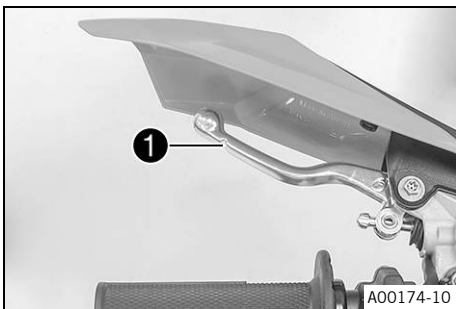

Rear brake lever ① is fitted on the left side of the handlebar.

**6.3 Throttle grip**

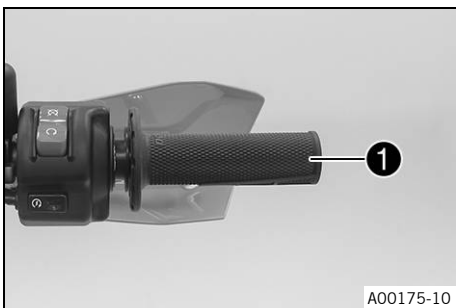

The throttle grip ① is fitted on the right side of the handlebar.

**6.4 Main switch**

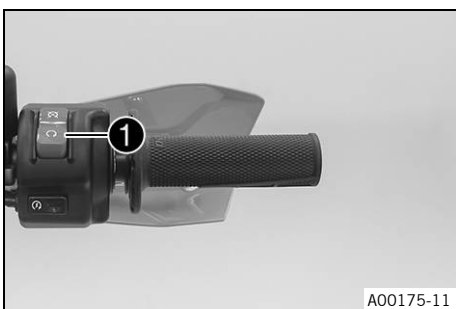

The main switch ① is attached to the right side of the handlebar. The main switch is used as the emergency OFF switch.

**Possible states**

	Vehicle switched off. – In this position, the vehicle is switched off.
	The vehicle is ready for operation – In this position, the vehicle is ready for operation. The start button is active.

## 6.5 Start button

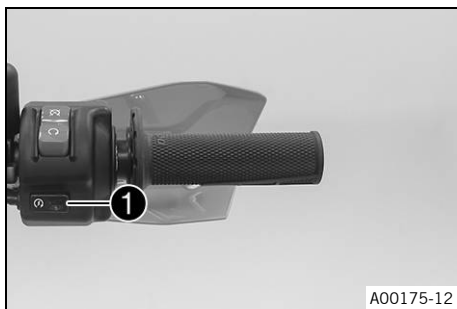

Start button **1** is fitted on the right side of the handlebar. The start button is only enabled when the main switch is switched on.

When the start button is pushed, the vehicle switches from standby to ready mode. The riding mode indicator and an acoustic signal indicate operating readiness.

When the start button is pushed again, the vehicle switches back to standby mode. The riding mode indicator goes out.

### **i** Info

Standby mode can only be switched to ready mode if the throttle grip is fully closed and the vehicle speed is less than 5 km/h. If the vehicle is not moved for 90 seconds after ready mode is activated and the throttle grip is not twisted open, the vehicle automatically switches back to standby mode.

### Possible states

- The start button is in the basic position – The state of the vehicle is retained.
- The start button is pressed – The state of the vehicle changes between ready mode and standby mode.

## 6.6 Horn button

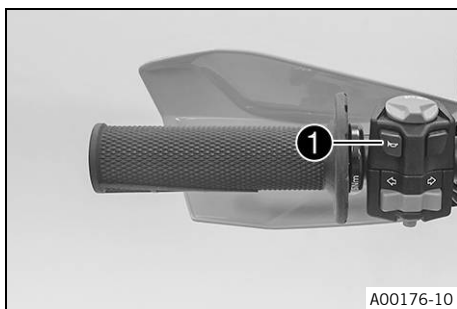

Horn button **1** is fitted on the left side of the handlebar.

### Possible states

- The horn button is in the basic position
- The horn button is pressed – The horn is operated in this position.

## 6.7 Light switch

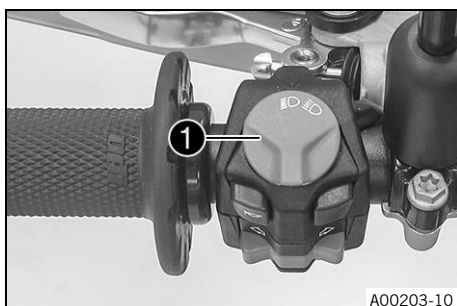

The light switch **1** is fitted on the left side of the handlebar.

### Possible states

	Low beam on – Light switch is in the central position. In this position, the low beam and tail light are switched on.
	High beam on – Light switch is turned to the left. In this position, the high beam and the tail light are switched on.

6.8 Turn signal switch

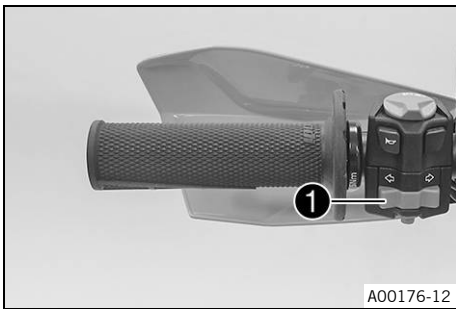

Turn signal switch ① is fitted on the left side of the handlebar.

Possible states

	Turn signal light off – Turn signal switch is in the central position.
←	Turn signal light, left, on – Turn signal switch is turned to the left.
→	Turn signal light, right, on – Turn signal switch is turned to the right.

6.9 Side stand

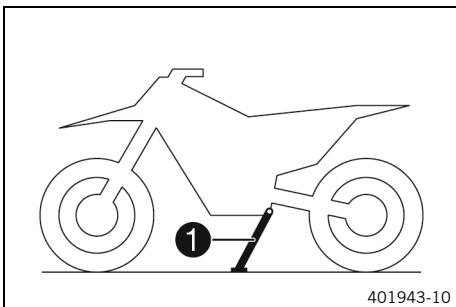

The side stand ① is located on the left of the vehicle.

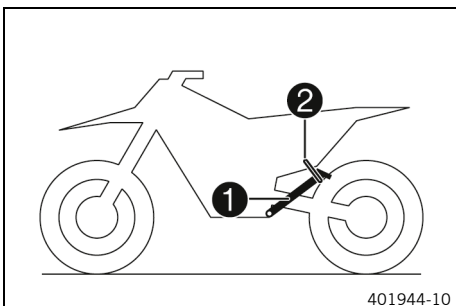

The side stand is used for parking the motorcycle.

**i** Info

When you are riding, side stand ① must be folded up and secured with rubber strap ②.

6.10 Ignition lock

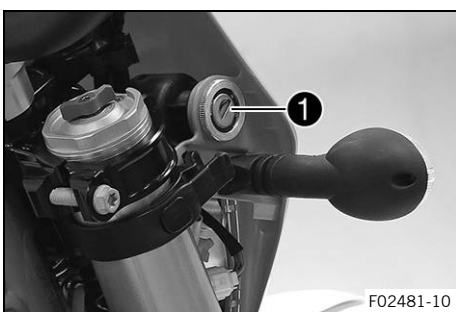

The ignition lock ① is on the right behind the headlight mask.

**i** Info

When the ignition is switched on at the ignition lock, quickly activate the vehicle with the main switch. When the ignition is switched on and the main switch is switched off, the 12-V battery discharges very quickly because, in this state, the lighting is powered by the 12-V battery instead of the Powerpack HV.

Possible states

	Ignition off – In this position, the electric circuit of the 12-V battery is interrupted and the vehicle cannot be activated.
	Ignition on – In this position, the electric circuit of the 12-V battery is closed and the vehicle can be started.

## 6.11 Steering lock

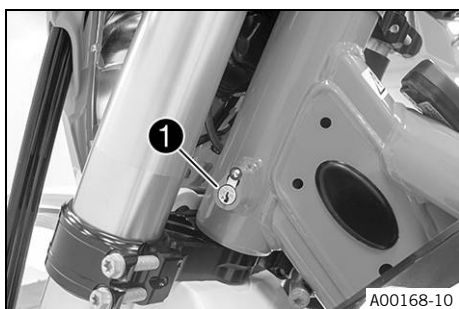

Steering lock ❶ is fitted on the left side of the steering head. The steering lock is used to lock the steering. Steering, and therefore riding, is no longer possible.

## 6.12 Locking the steering

### Note

**Danger of damage** The parked vehicle can roll away or fall over.

- Park the vehicle on a firm and level surface.



- Park the vehicle.
- Deactivate the vehicle. (🗨️ p. 43)
- Turn the handlebar as far as possible to the right.
- Lubricate the steering lock regularly.

Universal oil spray (🗨️ p. 145)

- Insert the ignition key in the steering lock, turn it to the left, press it in, and turn it to the right. Remove the ignition key.
- ✓ Steering is no longer possible.



### Info

Never leave the ignition key in the steering lock.

## 6.13 Unlocking the steering

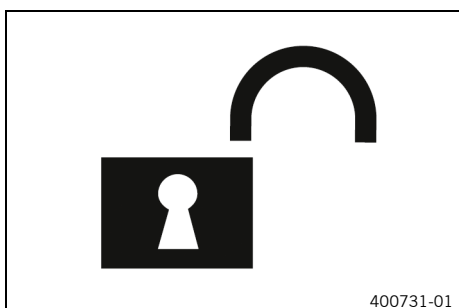

- Insert the ignition key in the steering lock, turn it to the left, pull it out, and turn it to the right. Remove the ignition key.
- ✓ The handlebar can now be moved again.



### Info

Never leave the ignition key in the steering lock.



**7.1 Multifunctional element**

**7.1.1 Multifunctional element**

The multifunctional element is mounted in front of the seat.

**Overview of multifunctional element**

- ❶ Riding mode button (📖 p. 23)
- ❷ Driving mode display (📖 p. 24)
- ❸ Malfunction indicator lamp (📖 p. 24)
- ❹ Charge level indicator (📖 p. 24)

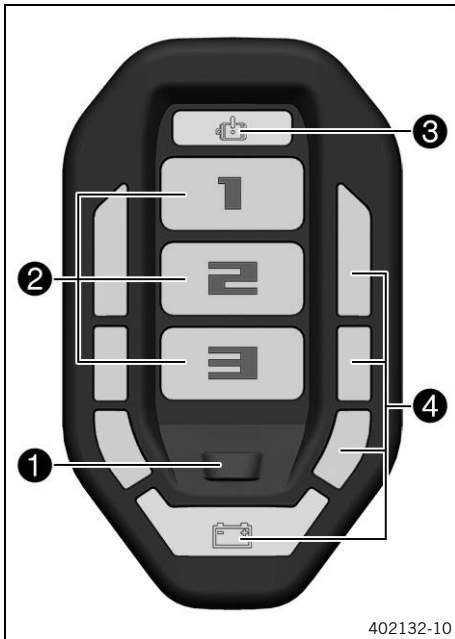

**7.1.2 Riding mode button**

The riding mode button ❶ determines the ride mode.

**Possible states**

- The vehicle is in standby mode – The riding mode button is active.
- The vehicle is in ready mode – The riding mode button is active.
- All other vehicle conditions – The riding mode button is not active.

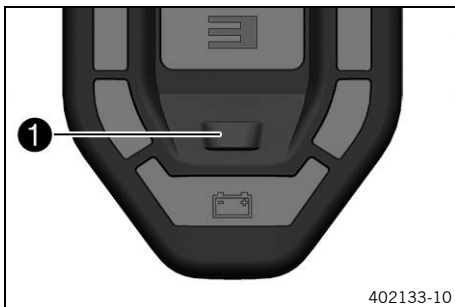

## 7.1.3 Driving mode display

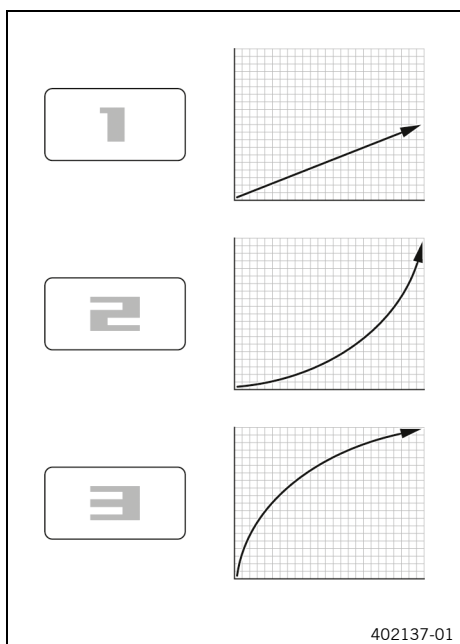

Red driving mode displays with the numbers **1**, **2** or **3** show the driving mode selected.

Three different driving modes are available. The driving modes determine how the vehicle reacts to throttle grip operation.

The figures only show approximate values for illustrative purposes, and do not describe the actual reaction.

Driving mode **1** is Economy: the motor torque is reduced by half. Driving mode **2** is Standard: the further the throttle grip is twisted open, the more the motor power increases.

Driving mode **3** is Advanced: the greatest increase in power occurs immediately, after which the motor power increases more slowly.

## 7.1.4 Malfunction indicator lamp

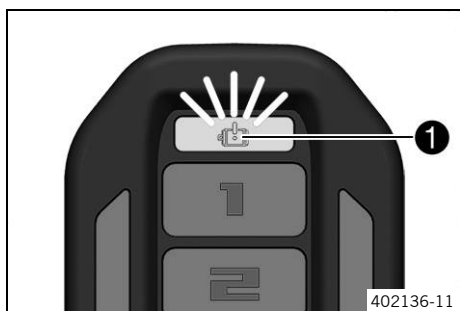

The warning tones emitted by the multifunctional element are synchronized with the flashing rhythm of malfunction indicator lamp **1**.

### Possible states

	The malfunction indicator lamp flashes – There is a malfunction in the vehicle electronic system.
	The malfunction indicator lamp lights up – The system is carrying out a self-check or has been disabled during driving.

## 7.1.5 Charge level indicator

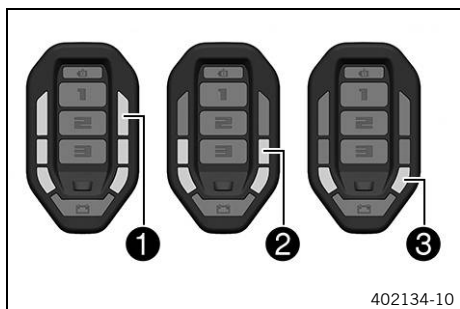

All segments **1** light up: charging level 70 % - 100%.

Four segments **2** light up: charging level 50 % - 70 %.

Two segments **3** light up: charging level 30 % - 50 %.

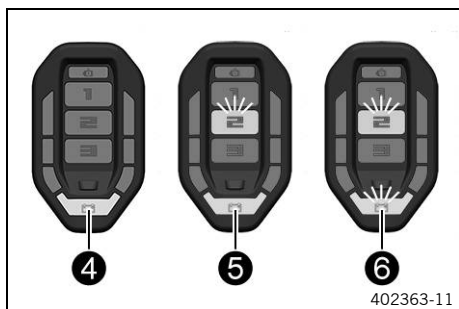

The last segment ④ lights up in yellow: charging level 20% - 30 %.

The last segment ⑤ lights up in red and the driving mode indicator flashes red: charging level 10%–20%.

The last segment ⑥ and the driving mode indicator light up in red: charging level 0%–10%.

### 7.1.6 Power reduction

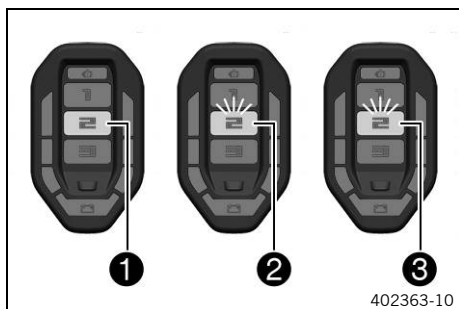

**The selected riding mode ① lights up:**

- The vehicle is ready for operation and provides full power.

**The selected riding mode ② flashes slowly:**

- The charging level of the Powerpack HV is low. The system is still fully operable.
- High temperature; the system is still fully operable. The driving style must be adapted.
- Low temperature; the system provides 80 % of power at temperatures of less than 9 °C and 50 % of power at temperatures of less than 0 °C.

When the Powerpack HV has warmed up sufficiently, 80% of power or full power is available, depending on the temperature, once the vehicle has been started again.

**The selected riding mode ③ alternately flashes slow and fast:**

- Power is still reduced considerably due to temperature monitoring, but 100% power is restored after the vehicle is restarted.

**All three riding mode indicators light up and the yellow malfunction indicator lamp ④ flashes (blink code 22, 23, or 24):**

- The system has exceeded the operating temperature. To protect the system from damage, the power is reduced considerably. Park the vehicle, if possible, and allow it to cool down. Full power is only enabled when the component concerned has cooled down and the vehicle has been started again.

**All three riding mode indicators light up and the yellow malfunction indicator lamp ⑤ flashes with a different rhythm:**

- The system provides 50 % of power as an emergency operation program.

**The selected riding mode ⑥ flashes slowly and the charge level indicator lights up red or flashes red:**

- The charging level of the Powerpack HV is below 20%. Vehicle power will be reduced. Park the vehicle and charge the Powerpack HV.

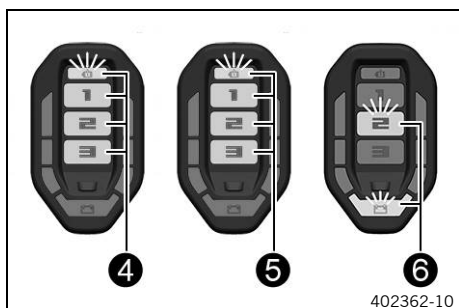

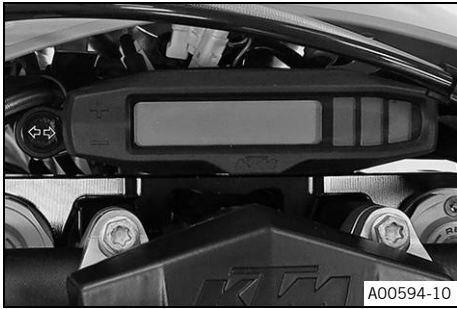

## 7.2 Overview

### 7.2.1 Overview of indicator lamps



#### Possible states

	The high beam indicator lamp lights up blue – The high beam is switched on.
	Turn signal indicator lamp flashes green – The turn signal is switched on.

## 8.1 Combination instrument overview

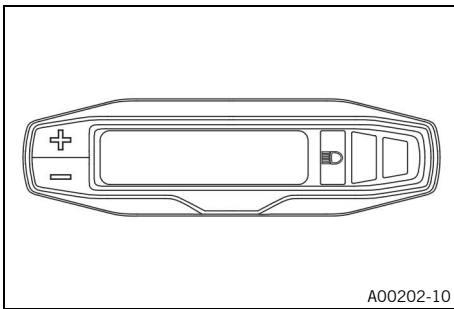

A00202-10

- Press the button **+** to control different functions.
- Press the button **➔** to control different functions.



### Info

When the vehicle is delivered, only the **SPEED/H** and **SPEED/ODO** display modes are activated.

## 8.2 Activation and test

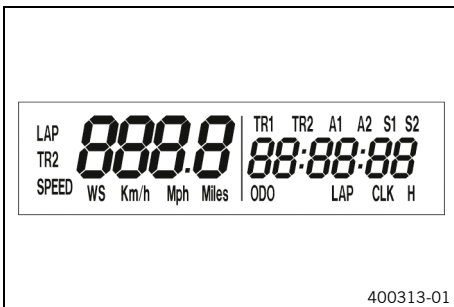

400313-01

### Activating combination instrument

The combination instrument is activated when one of the buttons is pressed or an impulse comes from the wheel speed sensor.

### Display test

To enable you to check that the display is functioning properly, all display segments light up briefly.

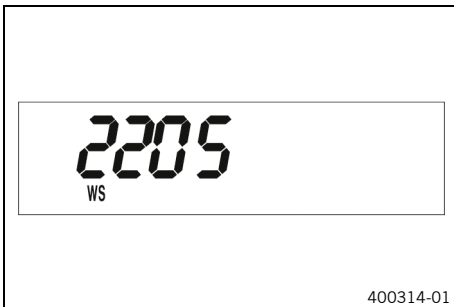

400314-01

### WS (wheel size)

After the display function check, the wheel circumference **WS** is displayed briefly.



### Info

The number 2205 equals the circumference of the 21" front wheel with standard tires.

The display then changes to the last selected mode.

## 8.3 Setting the kilometers or miles



### Info

If you change the unit, the value **ODO** is retained and converted accordingly. The values **TR1**, **TR2**, **A1**, **A2** and **S1** are cleared when the unit of measure is changed.

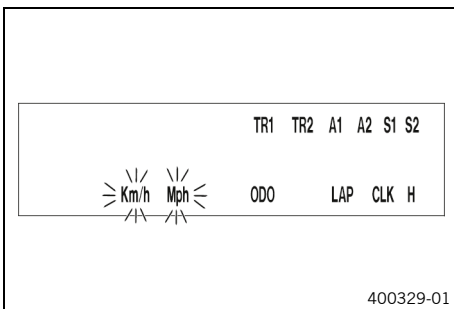

400329-01

### Condition

The motorcycle is stationary.

- Repeatedly press the button **+** briefly until **H** appears at the bottom right of the display.
- Press the button **+** for 2–3 seconds.
  - ✓ The Setup menu is displayed and the active functions are shown.
- Repeatedly press the button **+** briefly until **Km/h / Mph** flashes.

### Adjusting the Km/h

- Press the button **+**.

### Adjusting the Mph

- Press the button **➔**.

- Wait 3 - 5 seconds.
- ✓ The settings are stored.



### Info

If no button is pressed for 10–12 seconds, or if an impulse comes from the wheel speed sensor, the settings are automatically saved and the setup menu is closed.

## 8.4 Setting the combination instrument



### Info

When the vehicle is delivered, only the **SPEED/H** and **SPEED/ODO** display modes are activated.

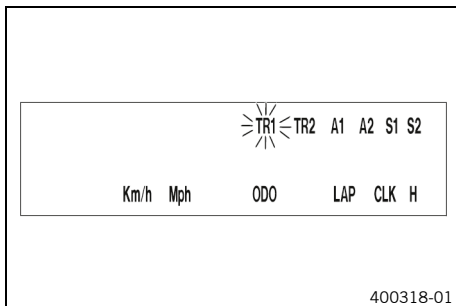

### Condition

The motorcycle is stationary.

- Repeatedly press the button briefly until **H** appears at the bottom right of the display.
- Press the button for 2–3 seconds.
- ✓ The Setup menu is displayed and the active functions are shown.



### Info

If no button is pressed for 10 - 12 seconds, the settings are automatically saved.  
If no button is pressed for 20 seconds, or if an impulse comes from the wheel speed sensor, the settings are automatically saved and the setup menu is closed.

- Repeatedly press the button briefly until the desired function flashes.
- ✓ The selected function flashes.

### Activating the function

- Press the button .
- ✓ The symbol continues to appear in the display and the next function appears.

### Deactivating a function

- Press the button .
- ✓ The symbol disappears in the display and the next function appears.

## 8.5 Setting the clock

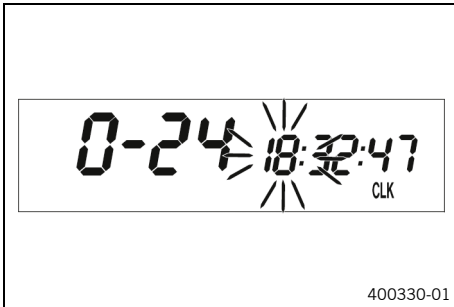

### Condition

The motorcycle is stationary.

- Repeatedly press the button **+** briefly until **CLK** appears at the bottom right of the display.
- Press the button **+** for 2–3 seconds.
  - ✓ The hour display flashes.
- Adjust the hour display with the button **+** and/or button **-**.
- Wait 3 - 5 seconds.
  - ✓ The next segment of the display flashes and can be set.
- You can set the following segments in the same way as the hours by pressing the button **+** and the button **-**.



### Info

The seconds can only be set to zero.

If no button is pressed for 15–20 seconds, or if an impulse comes from the wheel speed sensor, the settings are automatically saved and the setup menu is closed.

## 8.6 Viewing the lap time



### Info

This function can only be opened if lap times have actually been timed.

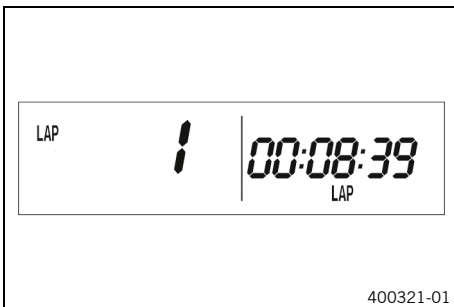

### Condition

The motorcycle is stationary.

- Repeatedly press the button **+** briefly until **LAP** appears at the bottom right of the display.
- Briefly press the button **+**.
  - ✓ **LAP 1** appears on the left side of the display.
- The laps 1 - 10 can be viewed with the button **-**.
- Press and hold the button **+** for 3 - 5 seconds.
  - ✓ The lap times are deleted.
- Briefly press the button **+**.
  - ✓ Next display mode



### Info

When an impulse is received from the wheel speed sensor, the left side of the display changes back to the **SPEED** mode.

## 8.7 Display mode SPEED (speed)



- Repeatedly press the button  $\oplus$  briefly until **SPEED** appears on the left side of the display.

The current speed is displayed in the **SPEED** display mode. The current speed can be displayed in **Km/h** or **Mph**.

**i Info**  
Make the setting according to the country. When an impulse comes from the front wheel, the left side of the display changes to the **SPEED** mode and the current speed is shown.

## 8.8 Display mode SPEED/H (operating hours)



### Condition

- The motorcycle is stationary.
- Repeatedly press the button  $\oplus$  briefly until **H** appears at the bottom right of the display.

In display mode **H**, the service hours of the motor are displayed. The service hour counter stores the total traveling time.

**i Info**  
The service hour counter is necessary for ensuring that service work is carried out at the right intervals. If the combination instrument is in **H** display mode when starting off, it automatically changes to the **ODO** display mode. The **H** display mode is suppressed during the journey.

Press the button $\oplus$ for 2–3 seconds.	The display changes to the functions setup menu.
Briefly press the button $\oplus$ .	Next display mode
Press the button $\ominus$ for 2–3 seconds.	No function
Briefly press the button $\ominus$ .	No function

## 8.9 Setup menu

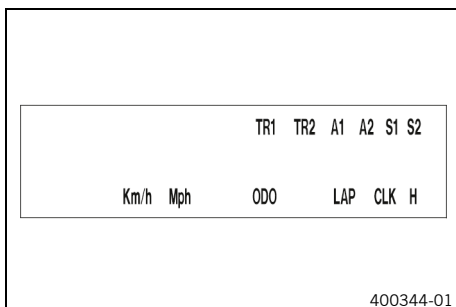

### Condition





- The motorcycle is stationary.
- Repeatedly press the button  $\oplus$  briefly until **H** appears at the bottom right of the display.
- Press the button  $\oplus$  for 2–3 seconds.

The Setup menu displays the active functions.



**i Info**



Repeatedly press the button  briefly until the desired function is reached.  
If no button is pressed for 20 seconds, the settings are automatically saved.

Briefly press the button  .	Activates the flashing display and changes to the next display
Press the button  for 2–3 seconds.	No function
Briefly press the button  .	Deactivates the flashing display and changes to the next display
Press the button  for 2–3 seconds.	No function
Wait 3 - 5 seconds.	Changes to the next display without changes
Wait 10 - 12 seconds.	Setup menu starts, stores the settings, and changes to <b>H</b> or <b>ODO</b> .

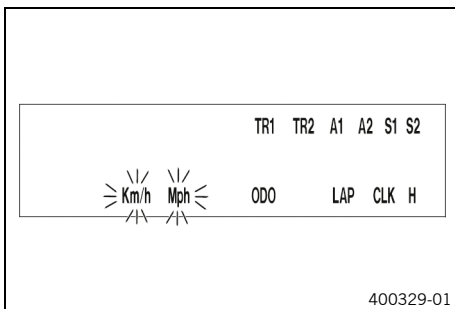
## 8.10 Adjusting the unit of measurement







**Condition**

- The motorcycle is stationary.
- Repeatedly press the button  briefly until **H** appears at the bottom right of the display.
- Press the button  for 2–3 seconds.
- Repeatedly press the button  briefly until **Km/h / Mph** flashes. In measurement unit mode, you can change the unit of measurement.

**i Info**

If no button is pressed for 5 seconds, the settings are automatically saved.

Briefly press the button  .	Starts selection, activates <b>Km/h</b> display
Press the button  for 2–3 seconds.	No function
Briefly press the button  .	Activates <b>Mph</b> display
Press the button  for 2–3 seconds.	No function
Wait 3 - 5 seconds.	Changes to the next display, changes from selection to the Setup menu
Wait 10 - 12 seconds.	Stores and closes the Setup menu

## 8.11 Display mode SPEED/CLK (time)

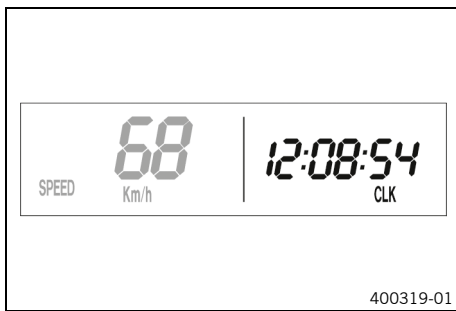

- Repeatedly press the button  $\oplus$  briefly until **CLK** appears at the bottom right of the display.

The time is shown in display mode **CLK**.

Press the button $\oplus$ for 2–3 seconds.	The display changes to the Setup menu of the clock.
Briefly press the button $\oplus$ .	Next display mode
Press the button $\ominus$ for 2–3 seconds.	No function
Briefly press the button $\ominus$ .	No function

## 8.12 Setting the clock



### Condition

- The motorcycle is stationary.
- Repeatedly press the button  $\oplus$  briefly until **CLK** appears at the bottom right of the display.
- Press the button  $\oplus$  for 2–3 seconds.

Press the button $\oplus$ for 2–3 seconds.	Increases the value
Briefly press the button $\oplus$ .	Increases the value
Press the button $\ominus$ for 2–3 seconds.	Reduces the value
Briefly press the button $\ominus$ .	Reduces the value
Wait 3 - 5 seconds.	Changes to the next value
Wait 10 - 12 seconds.	Leaving the SETUP menu





## 8.13 Display mode SPEED/LAP (lap time)



- Repeatedly press the button  $\oplus$  briefly until **LAP** appears at the bottom right of the display.

In the **LAP** display mode, up to 10 lap times can be timed with the stop watch.



**i Info**  
If the lap time continues running after the button  $\ominus$  is pressed, 9 memory locations are occupied. Lap 10 must be timed using the button  $\oplus$ .



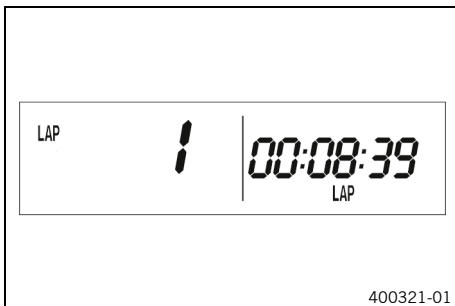

Press the button  for 2–3 seconds.	The stop watch and the lap time are reset.
Briefly press the button  .	Next display mode
Press the button  for 2–3 seconds.	Stops the clock.
Briefly press the button  .	Starts the stop watch or stop the current lap time measurement, stores it and the stop watch starts the next lap.

### 8.14 Viewing the lap time



**Condition**

- The motorcycle is stationary.
- Repeatedly press the button  briefly until **LAP** appears at the bottom right of the display.
- Briefly press the button .





Press the button  for 2–3 seconds.	The stop watch and the lap time are reset.
Briefly press the button  .	Select a lap from 1 – 10
Press the button  for 2–3 seconds.	No function
Briefly press the button  .	View the next lap time.

### 8.15 Display mode SPEED/ODO (odometer)



- Repeatedly press the button  briefly until **ODO** appears at the bottom right of the display.

The total traveled distance is shown in display mode **ODO**.

Press the button  for 2–3 seconds.	No function
Briefly press the button  .	Next display mode
Press the button  for 2–3 seconds.	No function
Briefly press the button  .	No function

## 8.16 Display mode SPEED/TR1 (trip master 1)

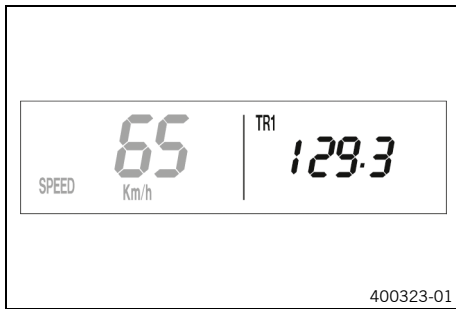

- Repeatedly press the button briefly until **TR1** appears at the top right of the display.

**TR1** (trip master 1) runs constantly and counts up to 999.9. You can use it to measure the distance covered during trips or the distance between two charging stops.

**TR1** is coupled with **A1** (average speed 1) and **S1** (stop watch 1).

**Info**  
If 999.9 is exceeded, the values of **TR1**, **A1** and **S1** are automatically reset to 0.0.

Press the button  for 2–3 seconds.	Displays of <b>TR1</b> , <b>A1</b> and <b>S1</b> are reset to 0.0.
Briefly press the button .	Next display mode
Press the button  for 2–3 seconds.	No function
Briefly press the button .	No function

## 8.17 Display mode SPEED/TR2 (trip master 2)

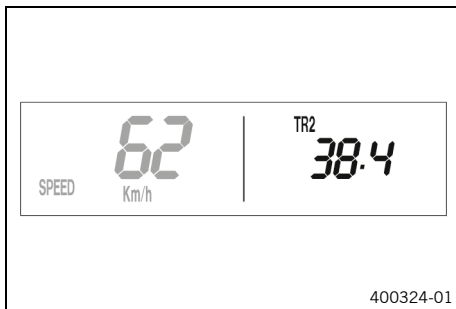

- Repeatedly press the button briefly until **TR2** appears at the top right of the display.

**TR2** (trip master 2) runs constantly and counts up to 999.9.

Press the button  for 2–3 seconds.	Clears the values <b>TR2</b> and <b>A2</b> .
Briefly press the button .	Next display mode
Press the button  for 2–3 seconds.	Reduces value of <b>TR2</b> .
Briefly press the button .	Reduces value of <b>TR2</b> .

## 8.18 Adjusting TR2 (trip master 2)

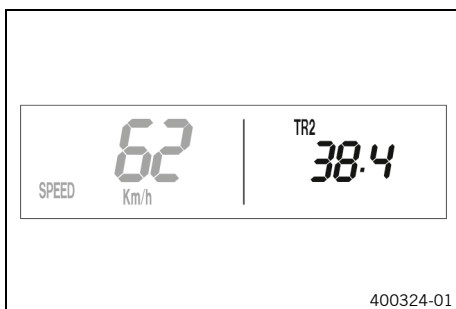

### Condition

- The motorcycle is stationary.
- Repeatedly press the button briefly until **TR2** appears at the top right of the display.
- Press the button for 2–3 seconds until **TR2** flashes.

The displayed value can be set manually with the button and the button . This is a very practical function when riding using the road book.

**i** **Info**

The **TR2** value can also be corrected manually during the journey with the button **+** and the button **-**.  
If 999.9 is exceeded, the value of **TR2** is automatically reset to 0.0.

Press the button <b>+</b> for 2–3 seconds.	Increases value of <b>TR2</b> .
Briefly press the button <b>+</b> .	Increases value of <b>TR2</b> .
Press the button <b>-</b> for 2–3 seconds.	Reduces value of <b>TR2</b> .
Briefly press the button <b>-</b> .	Reduces value of <b>TR2</b> .
Wait 10 - 12 seconds.	Stores and closes the Setup menu.

## 8.19 Display mode SPEED/A1 (average speed 1)

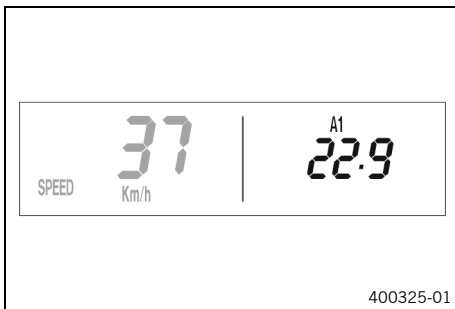

- Repeatedly press the button **+** briefly until **A1** appears at the top right of the display.

**A1** (average speed 1) shows the average speed calculated using **TR1** (trip master 1) and **S1** (stop watch 1).

The calculation of this value is activated by the first impulse of the wheel speed sensor and ends 3 seconds after the last impulse.

Press the button <b>+</b> for 2–3 seconds.	Displays of <b>TR1</b> , <b>A1</b> and <b>S1</b> are reset to 0.0.
Briefly press the button <b>+</b> .	Next display mode
Press the button <b>-</b> for 2–3 seconds.	No function
Briefly press the button <b>-</b> .	No function

## 8.20 Display mode SPEED/A2 (average speed 2)



- Repeatedly press the button **+** briefly until **A2** appears at the top right of the display.

**A2** (average speed 2) shows the average speed on the basis of the current speed if the stop watch **S2** (stop watch 2) is running.

**i** **Info**

The displayed value can differ from the actual average speed if **S2** was not stopped after the ride.

Briefly press the button <b>+</b> .	Next display mode
-------------------------------------	-------------------

# 8 COMBINATION INSTRUMENT

Press the button $\oplus$ for 2–3 seconds.	No function
Press the button $\ominus$ for 2–3 seconds.	No function
Briefly press the button $\ominus$ .	No function

## 8.21 Display mode SPEED/S1 (stop watch 1)



- Repeatedly press the button  $\oplus$  briefly until **S1** appears at the top right of the display.

**S1** (Stop watch 1) shows the riding time based on **TR1** and continues running as soon as an impulse arrives from the wheel speed sensor.

The calculation of this value starts with the first impulse from the wheel speed sensor and ends 3 seconds after the last impulse.

Press the button $\oplus$ for 2–3 seconds.	Displays of <b>TR1</b> , <b>A1</b> and <b>S1</b> are reset to 0.0.
Briefly press the button $\oplus$ .	Next display mode
Press the button $\ominus$ for 2–3 seconds.	No function
Briefly press the button $\ominus$ .	No function

## 8.22 Display mode SPEED/S2 (stop watch 2)



- Repeatedly press the button  $\oplus$  briefly until **S2** appears at the top right of the display.

**S2** (Stop watch 2) is a manual stop watch.

If **S2** is running in the background, the display **S2** flashes.

Press the button $\oplus$ for 2–3 seconds.	The displays of <b>S2</b> and <b>A2</b> are set to 0,0.
Briefly press the button $\oplus$ .	Next display mode
Press the button $\ominus$ for 2–3 seconds.	No function
Briefly press the button $\ominus$ .	Starts or stops <b>S2</b> .

**8.23 Table of functions**

Display	Press the button <b>+</b> for 2–3 seconds.	Briefly press the button <b>+</b> .	Press the button <b>-</b> for 2–3 seconds.	Briefly press the button <b>-</b> .	Wait 3 - 5 seconds.	Wait 10 - 12 seconds.
Display mode <b>SPEED/H</b> (operating hours)	The display changes to the functions setup menu.	Next display mode	No function	No function		
Setup menu	No function	Activates the flashing display and changes to the next display	No function	Deactivates the flashing display and changes to the next display	Changes to the next display without changes	Setup menu starts, stores the settings, and changes to <b>H</b> or <b>ODO</b> .
Adjusting the unit of measurement	No function	Starts selection, activates <b>Km/h</b> display	No function	Activates <b>Mph</b> display	Changes to the next display, changes from selection to the Setup menu	Stores and closes the Setup menu
Display mode <b>SPEED/CLK</b> (time)	The display changes to the Setup menu of the clock.	Next display mode	No function	No function		
Setting the clock	Increases the value	Increases the value	Reduces the value	Reduces the value	Changes to the next value	Leaving the SETUP menu
Display mode <b>SPEED/LAP</b> (lap time)	The stop watch and the lap time are reset.	Next display mode	Stops the clock.	Starts the stop watch or stop the current lap time measurement, stores it and the stop watch starts the next lap.		
Viewing the lap time	The stop watch and the lap time are reset.	Select a lap from 1 – 10	No function	View the next lap time.		
Display mode <b>SPEED/ODO</b> (odometer)	No function	Next display mode	No function	No function		
Display mode <b>SPEED/TR1</b> (trip master 1)	Displays of <b>TR1</b> , <b>A1</b> and <b>S1</b> are reset to 0.0.	Next display mode	No function	No function		
Display mode <b>SPEED/TR2</b> (trip master 2)	Clears the values <b>TR2</b> and <b>A2</b> .	Next display mode	Reduces value of <b>TR2</b> .	Reduces value of <b>TR2</b> .		

## 8 COMBINATION INSTRUMENT

Display	Press the button $\oplus$ for 2–3 seconds.	Briefly press the button $\oplus$ .	Press the button $\ominus$ for 2–3 seconds.	Briefly press the button $\ominus$ .	Wait 3 - 5 seconds.	Wait 10 - 12 seconds.
Adjusting <b>TR2</b> (trip master 2)	Increases value of <b>TR2</b> .	Increases value of <b>TR2</b> .	Reduces value of <b>TR2</b> .	Reduces value of <b>TR2</b> .		Stores and closes the Setup menu.
Display mode <b>SPEED/A1</b> (average speed 1)	Displays of <b>TR1</b> , <b>A1</b> and <b>S1</b> are reset to 0.0.	Next display mode	No function	No function		
Display mode <b>SPEED/A2</b> (average speed 2)	No function	Next display mode	No function	No function		
Display mode <b>SPEED/S1</b> (stop watch 1)	Displays of <b>TR1</b> , <b>A1</b> and <b>S1</b> are reset to 0.0.	Next display mode	No function	No function		
Display mode <b>SPEED/S2</b> (stop watch 2)	The displays of <b>S2</b> and <b>A2</b> are set to 0,0.	Next display mode	No function	Starts or stops <b>S2</b> .		

### 8.24 Table of conditions and menu activation

Display	The motorcycle is stationary.	Menu can be activated
Display mode <b>SPEED/H</b> (operating hours)	•	
Setup menu	•	
Adjusting the unit of measurement	•	
Setting the clock	•	
Display mode <b>SPEED/LAP</b> (lap time)		•
Viewing the lap time	•	
Display mode <b>SPEED/TR1</b> (trip master 1)		•
Display mode <b>SPEED/TR2</b> (trip master 2)		•
Adjusting <b>TR2</b> (trip master 2)	•	
Display mode <b>SPEED/A1</b> (average speed 1)		•
Display mode <b>SPEED/A2</b> (average speed 2)		•
Display mode <b>SPEED/S1</b> (stop watch 1)		•
Display mode <b>SPEED/S2</b> (stop watch 2)		•



9.1 Advice on preparing for first use

 **Danger**  
**Danger of accidents** A rider who is not fit to ride poses a danger to him or herself and others.

- Do not operate the vehicle if you are not fit to ride due to alcohol, drugs or medication.
- Do not operate the vehicle if you are physically or mentally impaired.

 **Warning**  
**Risk of injury** Missing or poor protective clothing presents an increased safety risk.

- Wear appropriate protective clothing such as helmet, boots, gloves as well as trousers and a jacket with protectors on all rides.
- Always wear protective clothing that is in good condition and meets the legal regulations.

 **Warning**  
**Danger of accidents** An unadapted riding style impairs the handling characteristic.

- Adapt your riding speed to the road conditions and your riding ability.

 **Warning**  
**Danger of accidents** The vehicle is not designed to carry passengers.

- Do not ride with a passenger.

 **Warning**  
**Danger of accidents** Total weight and axle loads influence the handling characteristic.

- Do not exceed the maximum permissible overall weight or the axle loads.

 **Warning**  
**Risk of misappropriation** People who act without authorization endanger themselves and others.

- Never leave the vehicle unattended.
- Protect the vehicle against access by unauthorized persons.

- Make sure that the pre-sales inspection work has been carried out by an authorized KTM workshop.
  - ✓ You will receive the delivery certificates when the vehicle is handed over.
- Before riding for the first time, read the entire Owner's Manual carefully.
- Get to know the controls.
- Adjust the free travel of the front brake lever. (📖 p. 79)
- Adjust the free travel of the rear brake lever. (📖 p. 86)
- Get used to the handling characteristic of the motorcycle in a suitable area before making a longer trip.

 **Info**  
 When offroad, it is recommended that you are accompanied by another person on another vehicle so that you can help each other.

- Try also to ride as slowly as possible and in a standing position to get a better feel for the motorcycle.
- Do not take any offroad trips that exceed your ability and experience.
- Hold the handlebar firmly with both hands and keep your feet on the footrests when riding.
- Do not exceed the maximum permissible weight and the maximum permissible axle loads.

Guideline

Maximum permissible overall weight	280 kg (617 lb.)
Maximum permissible front axle load	110 kg (243 lb.)
Maximum permissible rear axle load	170 kg (375 lb.)

## 10.1 Checks and maintenance measures when preparing for use

### **i** Info

Before every trip, check the condition of the vehicle and ensure that it is safe to operate. The vehicle must be in perfect technical condition when it is being operated.

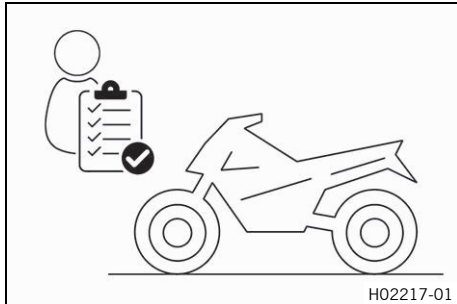

- Check the throttle grip, main switch, Powerpack HV, multi-functional element, and electric motor for external damage.
- Check the electrical system.
- Check the front brake fluid level. (📖 p. 80)
- Check the rear brake fluid level. (📖 p. 86)
- Check the front brake linings. (📖 p. 82)
- Check the rear brake linings. (📖 p. 88)
- Check that the brake system is functioning properly.
- Check the coolant level. (📖 p. 122)
- Check for chain dirt accumulation. (📖 p. 72)
- Check the chain, rear sprocket, engine sprocket, and chain guide. (📖 p. 75)
- Check the chain tension. (📖 p. 73)
- Check the tire condition. (📖 p. 95)
- Check tire pressure. (📖 p. 95)
- Check the spoke tension. (📖 p. 96)

### **i** Info

The spoke tension must be checked regularly as incorrect spoke tension will strongly impair riding safety.

- Clean the dust boots of the fork legs. (📖 p. 59)
- Bleed the fork legs. (📖 p. 58)
- Check the settings of all controls and ensure that they can be operated smoothly.
- Check all screws, nuts, and hose clamps for a tight fit.
- Check the charging level of the Powerpack HV.

## 10.2 Starting the vehicle

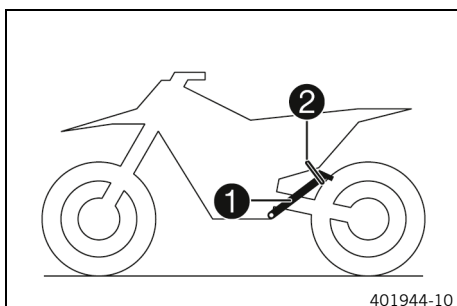

- Take the motorcycle off side stand **1** and secure the side stand with rubber strap **2**.
- Turn the ignition key in the ignition lock to the position  $\odot$ .

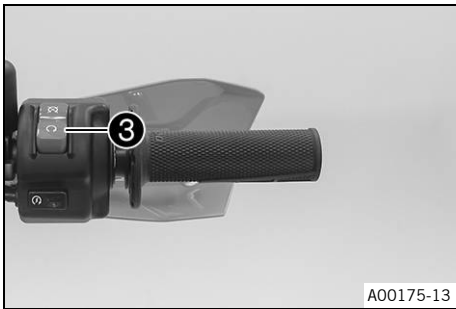

- Push main switch **3** into position **O**.
- ✓ The vehicle is ready for operation.

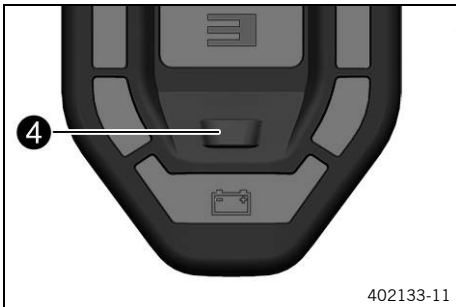

**Optional:**

- Press and hold riding mode button **4** for at least one second.
- ✓ The riding mode is activated when the tip switch is let go.

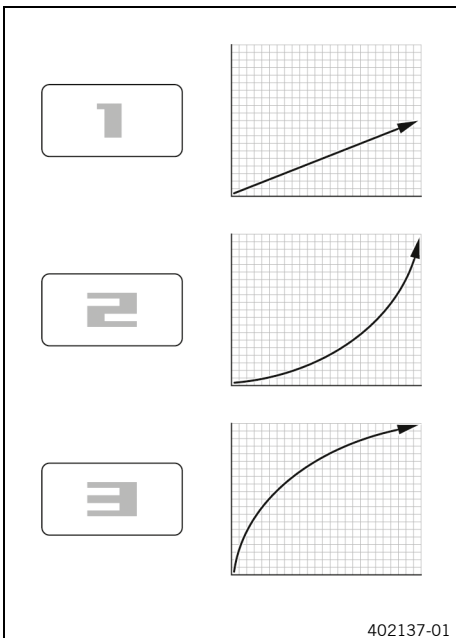

- Select one of the driving modes.

The riding mode **1** is Economy: the motor torque is reduced by half.

Riding mode **2** is Standard: the further the throttle grip is twisted open, the more the motor power increases.

The riding mode **3** is Advanced: the greatest increase in power occurs immediately, after which the motor power increases more slowly.



**Info**

A red riding mode display with the number **1**, **2**, or **3** shows the driving mode selected.

Three drive modes are available. The riding modes define how the vehicle will respond to operation of the throttle grip.

The figures contain approximate values for illustration purposes and do not show the actual response.

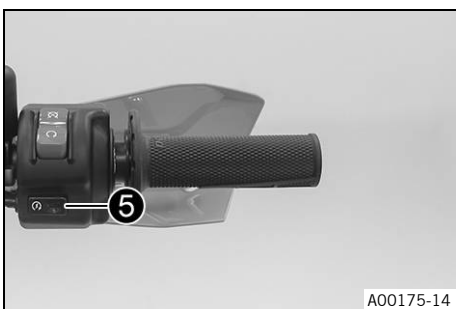

- Press start button **5**.
- ✓ The vehicle is ready for operation and responds to the throttle grip.



## 10.3 Starting off

### **i** Info

When you are riding, the side stand must be folded up and secured with the rubber strap.

- First familiarize yourself with the new riding and handling characteristic of this vehicle.
- Turn the throttle grip carefully. The absence of engine noise belies the actual power of the vehicle.

## 10.4 Recuperation

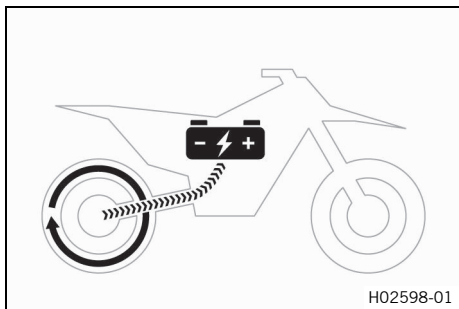

In riding mode **1** (Economy) (📖 p. 24), the Powerpack HV is charged by the electric motor when the throttle grip is fully closed in overrun.

Due to the recuperation function, there is an increased motor braking effect in riding mode **1**.

The recuperation effect increases with the motor speed.

### **i** Info

The recuperation function is not available in the riding mode **2** and **3**.

## 10.5 Braking



### **Warning**

**Danger of accidents** Excessively forceful application of the brakes blocks the wheels.

- Adjust application of the brakes to the respective riding situation and riding surface conditions.



### **Warning**

**Danger of accidents** A spongy pressure point on the front or rear brake reduces braking efficiency.

- Check the brake system and do not continue riding until the problem is eliminated. (Your authorized KTM workshop will be glad to help.)



### **Warning**

**Danger of accidents** Moisture and dirt impair the brake system.

- Brake carefully several times to dry out and remove dirt from the brake linings and the brake discs.

### **i** Info

The rear brake lever is located on the left side of the handlebar.

- To brake release the throttle and apply the front and rear brakes at the same time.
- On sandy, wet, or slippery surfaces, use mostly the rear brake if possible.
- Try to complete the braking procedure before riding into a curve.

## 10.6 Stopping, parking



### Warning

**Risk of misappropriation** People who act without authorization endanger themselves and others.

- Never leave the vehicle unattended.
- Protect the vehicle against access by unauthorized persons.



### Warning

**Danger of burns** Some vehicle components become very hot when the vehicle is operated.

- Do not touch any parts such as the radiator, motor, shock absorber, or brake system before these parts have cooled down.
- Let the vehicle parts cool down before you perform any work on the vehicle.

### Note

**Danger of damage** The parked vehicle can roll away or fall over.

- Park the vehicle on a firm and level surface.

### Note

**Fire hazard** Hot vehicle components pose a fire hazard and explosion risk.

- Do not park the vehicle near to materials which are highly flammable or explosive.
- Allow the vehicle to cool down before covering it.

- 
- Apply the brakes on the motorcycle.
  - Deactivate the vehicle. (📖 p. 43)
  - Park the motorcycle on its side stand on a firm surface.
  - Lock the steering. (📖 p. 22)



## 10.7 Deactivating the vehicle

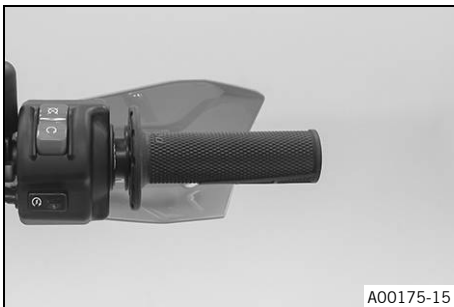

- Push the main switch into position ☒.



- Turn the ignition key in the ignition lock to the position ☒ while the vehicle is deactivated. Remove the ignition key.



## 10.8 Transporting the vehicle

### Note

**Danger of damage** The parked vehicle can roll away or fall over.

- Park the vehicle on a firm and level surface.

### Note

**Fire hazard** Hot vehicle components pose a fire hazard and explosion risk.

- Do not park the vehicle near to materials which are highly flammable or explosive.
- Allow the vehicle to cool down before covering it.

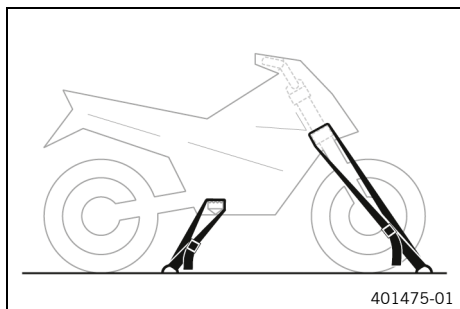

- Use tension belts or other suitable devices to secure the motorcycle against falling over or rolling away.

## 10.9 Transporting Powerpack HV



### Warning

**Risk of injury** The Powerpack HV is very heavy.

Serious injury may result if the Powerpack HV is not properly secured during transport. The transport vehicle may be damaged by an unsecured Powerpack HV.

- Secure the Powerpack HV with tension belts or other suitable fixing materials.
- 
- To ensure rapid access in the event of an emergency, always transport the Powerpack HV close to the cargo door.
  - Transport the Powerpack HV separately from flammable liquids or ignition sources such as fuel, gas, or oil.
  - Keep suitable fire extinguishers ready.

## 11.1 Additional information

Any further work that results from the compulsory work or from the recommended work must be ordered separately and invoiced separately.

Different service intervals may apply in your country, depending on the local operating conditions.

Individual service intervals and scopes may change in the course of technical developments. The most up-to-date service schedule can always be found on KTM Dealer.net. Your authorized KTM dealer will be happy to advise you.

## 11.2 Required work

	Every 80 operating hours	Every 50 operating hours	Every 20 operating hours when used for motorsports	After 1 operating hour
Read out the fault memory using the KTM diagnostics tool. 🛠️	○	●	●	●
Check that the electrical system is functioning properly. 🛠️	○	●	●	
Check and charge the 12 V battery. 🛠️		●	●	
Check and charge the Powerpack HV. 🛠️	○	●	●	
Check the front brake linings. (📖 p. 82)		●	●	
Check the rear brake linings. (📖 p. 88)		●	●	
Check the brake discs. (📖 p. 79)		●	●	
Check the brake lines for damage and leakage. 🛠️		●	●	
Check the frame. 🛠️ (📖 p. 77)		●	●	
Check the link fork. 🛠️ (📖 p. 77)		●	●	
Check the shock absorber heim joint for play. 🛠️		●	●	
Check the tire condition. (📖 p. 95)	○	●	●	
Check tire pressure. (📖 p. 95)	○	●	●	
Check the wheel bearing for play. 🛠️		●	●	
Check the wheel hubs. 🛠️		●	●	
Check the rim run-out. 🛠️	○	●	●	
Check the spoke tension. (📖 p. 96)	○	●	●	
Check the chain, rear sprocket, engine sprocket, and chain guide. (📖 p. 75)		●	●	
Check the chain tension. (📖 p. 73)	○	●	●	
Grease all moving parts (e.g. side stand, hand lever, chain, etc.) and check for smooth operation. 🛠️	○	●	●	
Check the front brake fluid level. (📖 p. 80)		●	●	
Check the rear brake fluid level. (📖 p. 86)		●	●	
Check the travel of the brake levers. 🛠️		●	●	
Check steering head bearing play. 🛠️ (📖 p. 64)	○	●	●	
Check all hoses and bellows for cracking, leakage and incorrect routing. 🛠️	○	●	●	
Check the antifreeze and coolant level. (📖 p. 121)	○	●	●	
Check the cables for damage and for routing without kinks. 🛠️		●	●	
Service the fork. 🛠️				●
Perform the shock absorber service. 🛠️				●
Check the battery discharge plug form ring. (📖 p. 71)	○	●	●	
Check the tightness of the easily accessible, safety-relevant screws and nuts. 🛠️	○	●	●	
Check the Powerpack HV fitting for the specified tightening torque. 🛠️	○	●	●	

# 11 SERVICE SCHEDULE

	Every 80 operating hours	Every 50 operating hours	Every 20 operating hours when used for motorsports	After 1 operating hour
Check the headlight setting. (📖 p. 105)	○	●	●	
Final check: Check the vehicle is roadworthy and take a test ride. 🛠️	○	●	●	
Read out the error memory after the test ride using the KTM diagnostics tool. 🛠️	○	●	●	
Make a service entry in <b>KTM Dealer.net</b> . 🛠️	○	●	●	●

- One-time interval
- Periodic interval

## 11.3 Recommended work

	Every 20 operating hours when used for motorsports	every 48 months	every 12 months	Every 100 operating hours	Every 50 operating hours	After 40 operating hours	After 20 operating hours
Change the front brake fluid. 🛠️							● ●
Change the rear brake fluid. 🛠️							● ●
Grease the steering head bearing. 🛠️ (📖 p. 66)							● ●
Change the battery discharge plug form ring. 🛠️				● ●			●
Service the fork. 🛠️	○						
Perform the shock absorber service. 🛠️		○					
Check the swingarm bearing for play. 🛠️				● ●			●
Change the gear oil. 🛠️ (📖 p. 128)				● ●			●
Change the coolant. (📖 p. 125)							●
Change all the motor bearings, the radial shaft seal rings and the bearing seals. 🛠️				●			

- One-time interval
- Periodic interval



## 12.1 Checking the basic chassis setting with the rider's weight

### **i** Info

When adjusting the basic chassis setting, first adjust the shock absorber and then the fork.

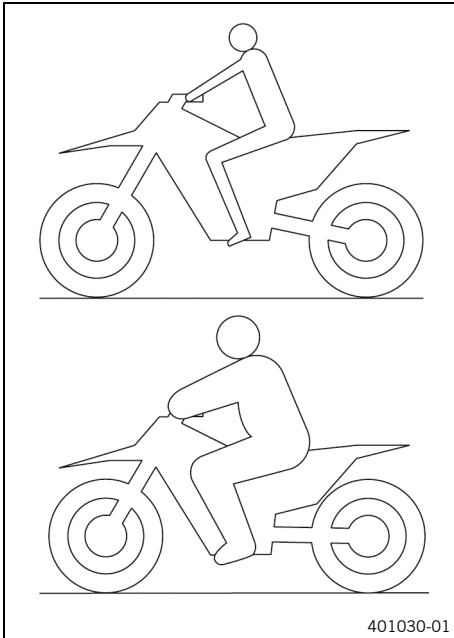

- For optimal motorcycle riding characteristics and to avoid damage to forks, shock absorbers, link fork and frame, the basic settings of the suspension components must match the rider's weight.
- As delivered, KTM offroad motorcycles are adjusted for a rider's weight (with full protective clothing).

#### Guideline

Standard rider weight	75 ... 85 kg (165 ... 187 lb.)
-----------------------	--------------------------------

- If the rider's weight is above or below this range, the basic setting of the suspension components must be adjusted accordingly.
- Small weight differences can be compensated by adjusting the spring preload, but in the case of large weight differences, the springs must be replaced.



## 12.2 Compression damping of the shock absorber

The compression damping of the shock absorber is divided into two ranges: high-speed and low-speed. High-speed and low-speed refer to the compression speed of the rear wheel suspension and not to the vehicle speed.

The high-speed compression adjuster has an effect, for example, when landing after a jump: the rear wheel suspension compresses quickly.

The low-speed compression adjuster has an effect, for example, when riding over long ground swells: the rear wheel suspension compresses slowly.

These two ranges can be adjusted separately, although the transition between high-speed and low-speed is gradual. Thus, modifications in the high-speed range affect the compression damping in the low-speed range and vice versa.

## 12.3 Adjusting the low-speed compression damping of the shock absorber



### Caution

**Risk of injury** Parts of the shock absorber will move around if the shock absorber is detached incorrectly. The shock absorber is filled with highly compressed nitrogen.

- Please follow the description provided. (Your authorized KTM workshop will be glad to help.)

### **i** Info

The low-speed compression adjuster takes effect during slow to normal compression of the shock absorber.

#### Preparatory work

- Deactivate the vehicle. (📖 p. 43)
- Fold the seat up. (📖 p. 69)
- Remove the Powerpack HV. (📖 p. 108)

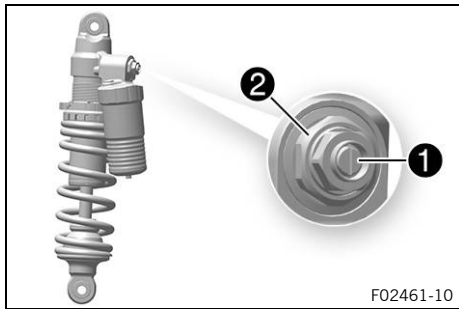

- Mount the protection cap. (🔧 p. 71)
- Raise the motorcycle with a lift stand. (🔧 p. 57)
- Remove the shock absorber. 🛠️ (🔧 p. 68)

### Main work

- Turn adjusting screw **1** clockwise with a screwdriver as far as the last perceptible click.



### Info

Do not loosen fitting **2**!

- Turn counterclockwise by the number of clicks corresponding to the shock absorber type.

### Guideline

Low-speed compression damping	
Comfort	18 clicks
Standard	15 clicks
Sport	12 clicks



### Info

Turn clockwise to increase damping; turn counterclockwise to reduce damping.

### Finishing work

- Install the shock absorber. 🛠️ (🔧 p. 68)
- Remove the motorcycle from the lift stand. (🔧 p. 57)
- Install the Powerpack HV. (🔧 p. 109)
- Lock the seat. (🔧 p. 69)

## 12.4 Adjusting the high-speed compression damping of the shock absorber 🛠️



### Caution

**Risk of injury** Parts of the shock absorber will move around if the shock absorber is detached incorrectly. The shock absorber is filled with highly compressed nitrogen.

- Please follow the description provided. (Your authorized KTM workshop will be glad to help.)



### Info

The high-speed compression adjuster takes effect during fast compression of the shock absorber.

### Preparatory work

- Deactivate the vehicle. (🔧 p. 43)
- Fold the seat up. (🔧 p. 69)
- Remove the Powerpack HV. (🔧 p. 108)
- Mount the protection cap. (🔧 p. 71)
- Raise the motorcycle with a lift stand. (🔧 p. 57)
- Remove the shock absorber. 🛠️ (🔧 p. 68)

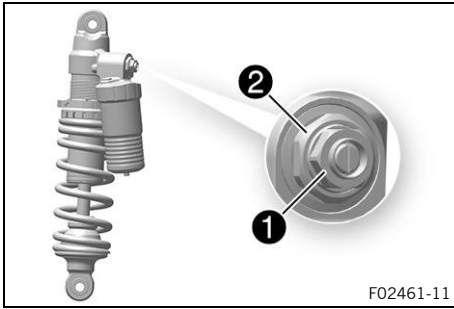

### Main work

- Turn adjusting screw ① all the way clockwise with a socket wrench.

**i Info**  
Do not loosen fitting ②!

- Turn counterclockwise by the number of turns corresponding to the shock absorber type.

### Guideline

High-speed compression damping	
Comfort	2 turns
Standard	2 turns
Sport	1.5 turns

**i Info**  
Turn clockwise to increase damping; turn counterclockwise to reduce damping.

### Finishing work

- Install the shock absorber. (📖 p. 68)
- Remove the motorcycle from the lift stand. (📖 p. 57)
- Install the Powerpack HV. (📖 p. 109)
- Lock the seat. (📖 p. 69)



## 12.5 Adjusting the rebound damping of the shock absorber



### Caution

**Risk of injury** Parts of the shock absorber will move around if the shock absorber is detached incorrectly. The shock absorber is filled with highly compressed nitrogen.

- Please follow the description provided. (Your authorized KTM workshop will be glad to help.)

### Preparatory work

- Deactivate the vehicle. (📖 p. 43)
- Fold the seat up. (📖 p. 69)
- Remove the Powerpack HV. (📖 p. 108)
- Mount the protection cap. (📖 p. 71)

### Main work

- Turn adjusting screw ① clockwise up to the last perceptible click.
- Turn counterclockwise by the number of clicks corresponding to the shock absorber type.

### Guideline

Rebound damping	
Comfort	18 clicks
Standard	15 clicks
Sport	12 clicks

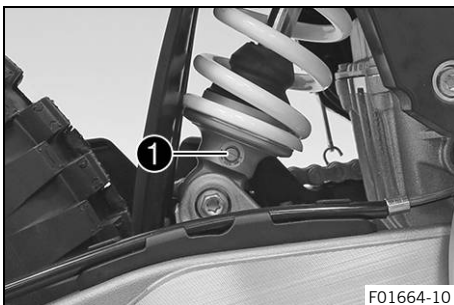

## **i** Info

Turn clockwise to increase damping; turn counterclockwise to reduce damping during rebound of the shock absorber.

### **Finishing work**

- Install the Powerpack HV. (🔧 p. 109)
- Lock the seat. (🔧 p. 69)

## 12.6 Measuring the rear wheel dimension unloaded

### **Preparatory work**

- Deactivate the vehicle. (🔧 p. 43)
- Fold the seat up. (🔧 p. 69)
- Remove the Powerpack HV. (🔧 p. 108)
- Mount the protection cap. (🔧 p. 71)
- Raise the motorcycle with a lift stand. (🔧 p. 57)

### **Main work**

- Measure the distance – as vertical as possible – between the rear axle and another fixed point, for example, a marking on the rear fairing.
- Note down the value as dimension **A**.

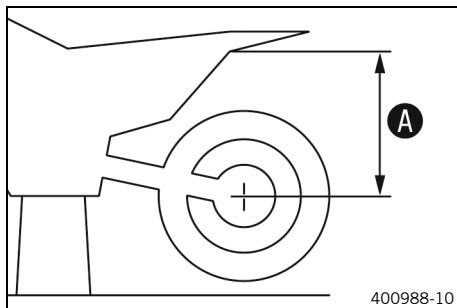

### **Finishing work**

- Remove the motorcycle from the lift stand. (🔧 p. 57)
- Install the Powerpack HV. (🔧 p. 109)
- Lock the seat. (🔧 p. 69)

## 12.7 Checking the static sag of the shock absorber

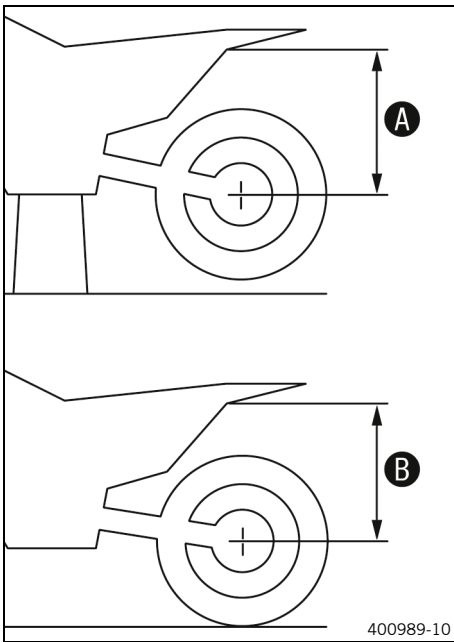

- Measure dimension **A** of rear wheel unloaded. (📖 p. 50)
- Hold the motorcycle upright with aid of an assistant.
- Measure the distance between rear axle and fixed point again.
- Note the value as dimension **B**.

**i Info**  
The static sag is the difference between measurements **A** and **B**.

- Check the static sag.

Static sag	25 mm (0.98 in)
------------	-----------------

- » If the static sag is less or more than the specified value:
  - Adjust the spring preload of the shock absorber. 🛠️ (📖 p. 52)



## 12.8 Checking the riding sag of the shock absorber

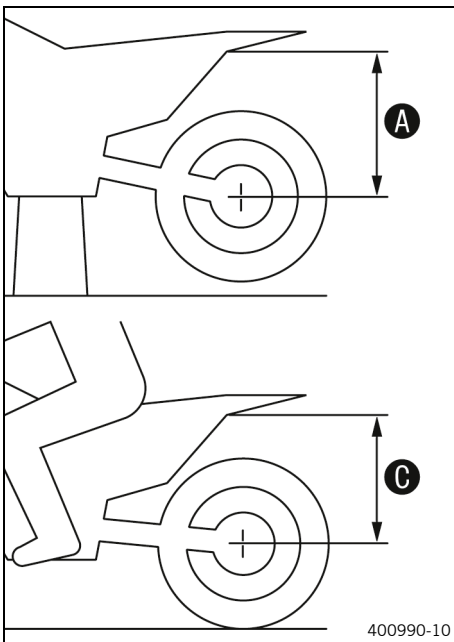

- Measure dimension **A** of rear wheel unloaded. (📖 p. 50)
- With another person holding the motorcycle, the rider, wearing full protective clothing, sits on the seat in a normal sitting position (feet on footrests) and bounces up and down a few times.
  - ✓ The rear wheel suspension levels out.
- Another person now measures the distance between the rear axle and the fixed point.
- Note the value as dimension **C**.

**i Info**  
The riding sag is the difference between measurements **A** and **C**.

- Check riding sag.

Riding sag	115 mm (4.53 in)
------------	------------------

- » If the riding sag differs from the specified measurement:
  - Adjust the riding sag. 🛠️ (📖 p. 53)



## 12.9 Adjusting the spring preload of the shock absorber ↩



### Caution

**Risk of injury** Parts of the shock absorber will move around if the shock absorber is detached incorrectly. The shock absorber is filled with highly compressed nitrogen.

- Please follow the description provided. (Your authorized KTM workshop will be glad to help.)



### Info

Before changing the spring preload, make a note of the present setting, e.g., by measuring the spring length.

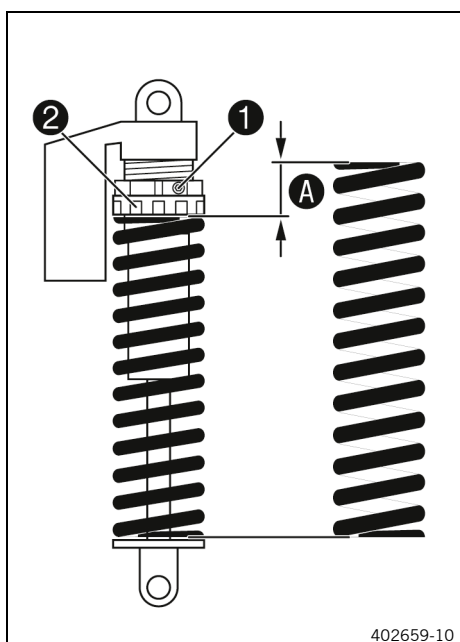

### Preparatory work

- Deactivate the vehicle. (🔧 p. 43)
- Fold the seat up. (🔧 p. 69)
- Remove the Powerpack HV. (🔧 p. 108)
- Mount the protection cap. (🔧 p. 71)
- Raise the motorcycle with a lift stand. (🔧 p. 57)
- Remove the shock absorber. ↩ (🔧 p. 68)
- After removing the shock absorber, clean it thoroughly.

### Main work

- Loosen screw ①.
- Turn adjusting ring ② until the spring is no longer under tension.

Hook wrench (90129051000)
---------------------------



### Info

If the spring cannot be fully released, the spring must be removed to accurately measure the spring length.

- Measure the total spring length while the spring is not under tension.
- Tension the spring by turning adjusting ring ② to specified dimension A.

Guideline

Spring preload	9 mm (0.35 in)
----------------	----------------



### Info

Depending on the static sag and/or the riding sag, it may be necessary to increase or decrease the spring preload.

- Tighten screw ①.

Guideline

Screw, shock absorber adjusting ring	M5	5 Nm (3.7 lbf ft)
--------------------------------------	----	-------------------

### Finishing work

- Install the shock absorber. ↩ (🔧 p. 68)
- Remove the motorcycle from the lift stand. (🔧 p. 57)
- Install the Powerpack HV. (🔧 p. 109)

- Lock the seat. (📖 p. 69)



## 12.10 Adjusting the riding sag 🛠️

### Preparatory work

- Deactivate the vehicle. (📖 p. 43)
- Fold the seat up. (📖 p. 69)
- Remove the Powerpack HV. (📖 p. 108)
- Mount the protection cap. (📖 p. 71)
- Raise the motorcycle with a lift stand. (📖 p. 57)
- Remove the shock absorber. 🛠️ (📖 p. 68)
- After removing the shock absorber, clean it thoroughly.

### Main work

- Choose and mount a suitable spring.

#### Guideline

Spring rate	
Weight of rider: 65 ... 75 kg (143 ... 165 lb.)	66 N/mm (377 lb/in)
Weight of rider: 75 ... 85 kg (165 ... 187 lb.)	68 N/mm (388 lb/in)
Weight of rider: 85 ... 95 kg (187 ... 209 lb.)	69 N/mm (394 lb/in)

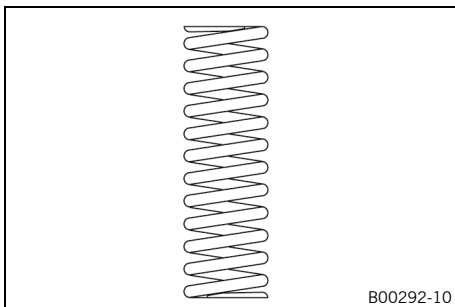

#### **i** Info

The spring rate is shown on the outside of the spring. Smaller weight differences can be compensated by changing the spring preload.

### Finishing work

- Install the shock absorber. 🛠️ (📖 p. 68)
- Remove the motorcycle from the lift stand. (📖 p. 57)
- Check the static sag of the shock absorber. (📖 p. 51)
- Check the riding sag of the shock absorber. (📖 p. 51)
- Adjust the rebound damping of the shock absorber. (📖 p. 49)
- Install the Powerpack HV. (📖 p. 109)
- Lock the seat. (📖 p. 69)



## 12.11 Checking the basic setting of the fork

#### **i** Info

For various reasons, no exact riding sag can be determined for the fork.

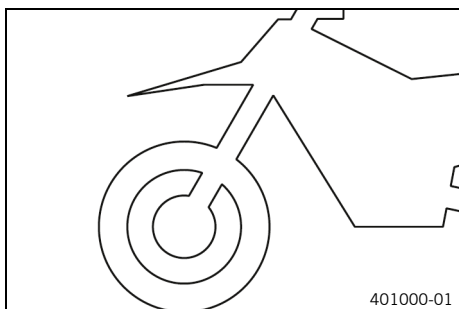

- As with the shock absorber, smaller differences in the rider's weight can be compensated by the spring preload.
- However, if the fork is often overloaded (hard end stop on compression), harder springs must be fit to avoid damage to the fork and frame.

## 12.12 Adjusting the compression damping of the fork

**i** **Info**

The hydraulic compression damping determines the fork suspension behavior.



- Turn white adjuster ① clockwise as far as it will go.

**i** **Info**

Adjuster ① is located at the upper end of the left fork leg. The compression damping is located in left fork leg **COMP** (white adjuster). The rebound damping is located in right fork leg **REB** (red adjuster).

- Turn counterclockwise by the number of clicks corresponding to the fork type.

Guideline

Compression damping	
Comfort	18 clicks
Standard	15 clicks
Sport	12 clicks

**i** **Info**

Turn clockwise to increase damping; turn counterclockwise to reduce damping during compression.

## 12.13 Adjusting the rebound damping of the fork

**i** **Info**

The hydraulic rebound damping determines the fork suspension behavior.



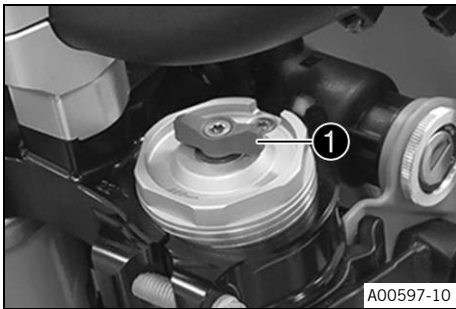

- Turn red adjuster **1** clockwise as far as it will go.

**i Info**  
Adjuster **1** is located at the upper end of the right fork leg.  
The rebound damping is located in right fork leg **REB** (red adjuster). The compression damping is located in left fork leg **COMP** (white adjuster).

- Turn counterclockwise by the number of clicks corresponding to the fork type.

Guideline

Rebound damping	
Comfort	18 clicks
Standard	15 clicks
Sport	12 clicks

**i Info**  
Turn clockwise to increase the damping; turn counterclockwise to reduce damping when the shock absorber rebounds.



## 12.14 Handlebar position

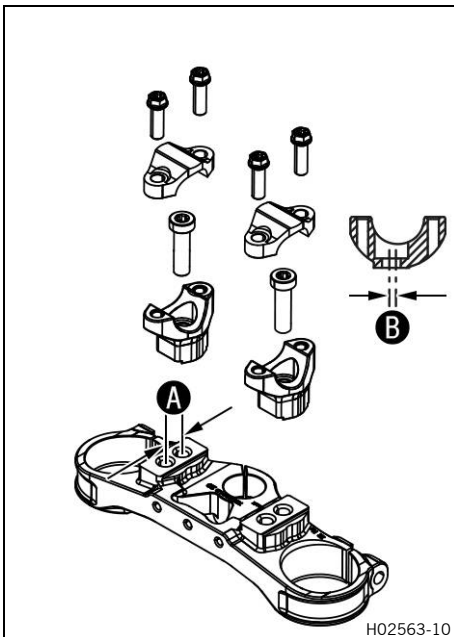

On the upper triple clamp, there are two holes at a distance of **A** to each other.

Hole distance <b>A</b>	15 mm (0.59 in)
------------------------	-----------------

The holes on the handlebar supports are placed at a distance of **B** from the center.

Hole distance <b>B</b>	3.5 mm (0.138 in)
------------------------	-------------------

The handlebar supports can be mounted in four different positions.

## 12.15 Adjusting the handlebar position



### Warning

**Danger of accidents** A repaired handlebar poses a safety risk.

If the handlebar is bent or straightened, the material becomes fatigued. The handlebar may break as a result.

- Change the handlebar if the handlebar is damaged or bent.

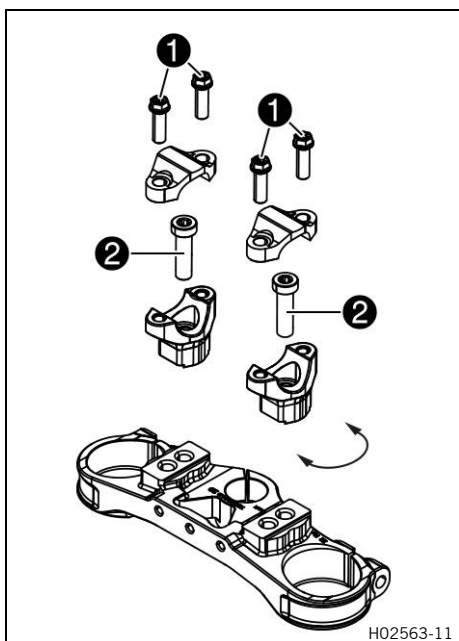

### Preparatory work

- Deactivate the vehicle. (🔧 p. 43)
- Fold the seat up. (🔧 p. 69)
- Remove the Powerpack HV. (🔧 p. 108)
- Mount the protection cap. (🔧 p. 71)

### Main work

- Remove screws **1**. Take off the handlebar clamps.
- Take off the handlebar and hang to the side.



### Info

Cover the components to protect them against damage. Do not kink the cables and lines.

- Remove screws **2**. Take off the handlebar supports.
- Place the handlebar supports in the required position. Mount and tighten screws **2**.

### Guideline

Screw, handlebar support	M10	40 Nm (29.5 lbf ft) <b>Loctite®243™</b>
--------------------------	-----	--



### Info

Position the left and right handlebar supports evenly.

- Position the handlebar.



### Info

Make sure the cables and wiring are positioned correctly.

- Position the handlebar clamps. Mount screws **1** and tighten evenly.

### Guideline

Screw, handlebar clamp	M8	20 Nm (14.8 lbf ft)
------------------------	----	---------------------



### Info

Make sure the gap widths are even.

### Finishing work

- Install the Powerpack HV. (🔧 p. 109)
- Lock the seat. (🔧 p. 69)

## 13.1 Raising the motorcycle with a lift stand

### Note

**Danger of damage** The parked vehicle can roll away or fall over.

- Park the vehicle on a firm and level surface.

### Preparatory work

- Deactivate the vehicle. (📖 p. 43)
- Fold the seat up. (📖 p. 69)
- Remove the Powerpack HV. (📖 p. 108)
- Mount the protection cap. (📖 p. 71)

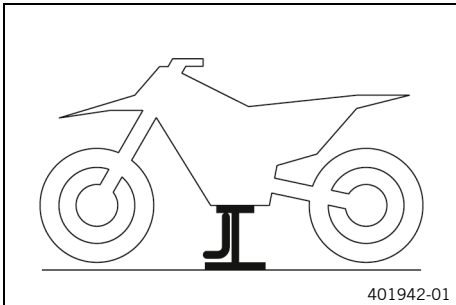

### Main work

- Use the motor guard underneath the motor to raise the vehicle.

Lift stand (78129955100)

- ✓ Neither wheel is in contact with the ground.
- Secure the motorcycle against falling over.



## 13.2 Removing the motorcycle from the lift stand

### Note

**Danger of damage** The parked vehicle can roll away or fall over.

- Park the vehicle on a firm and level surface.

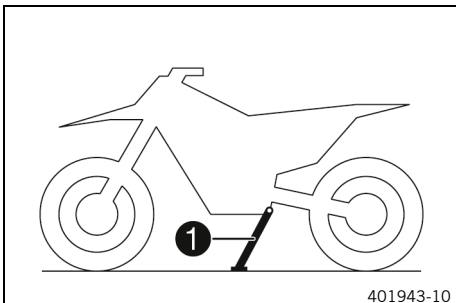

### Main work

- Remove the motorcycle from the lift stand.
- Remove the lift stand.
- To park the motorcycle, press side stand ① to the ground with your foot and lean the motorcycle on it.

### Info

When you are riding, the side stand must be folded up and secured with the rubber strap.

### Finishing work

- Install the Powerpack HV. (📖 p. 109)
- Lock the seat. (📖 p. 69)



## 13.3 Bleeding the fork legs

### Preparatory work

- Deactivate the vehicle. (📖 p. 43)
- Fold the seat up. (📖 p. 69)
- Remove the Powerpack HV. (📖 p. 108)
- Mount the protection cap. (📖 p. 71)
- Raise the motorcycle with a lift stand. (📖 p. 57)

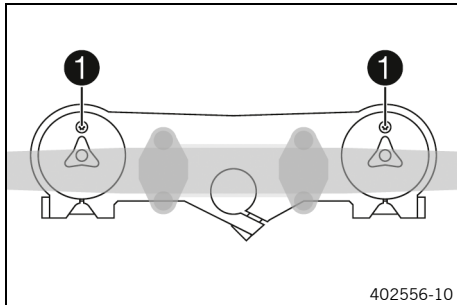

### Main work

- Release bleeder screws **1**.
- ✓ Any excess pressure escapes from the interior of the fork.
- Tighten the bleeder screws.

### Finishing work

- Remove the motorcycle from the lift stand. (📖 p. 57)
- Install the Powerpack HV. (📖 p. 109)
- Lock the seat. (📖 p. 69)

## 13.4 Removing the fork protector

### Preparatory work

- Deactivate the vehicle. (📖 p. 43)
- Fold the seat up. (📖 p. 69)
- Remove the Powerpack HV. (📖 p. 108)
- Mount the protection cap. (📖 p. 71)



### Main work

- Remove screws **1**. Take off the clamp.
- Remove screws **2** on the left fork leg. Take off the fork protector.



- Remove screws **3** on the right fork leg. Take off the fork protector.

## 13.5 Installing the fork protector



### Main work

- Position the fork protector on the right fork leg. Mount and tighten screws ①.

### Guideline

Remaining screws, chassis	M6	10 Nm (7.4 lbf ft)
---------------------------	----	--------------------



- Position the fork protector on the left fork leg. Mount and tighten screws ②.

### Guideline

Remaining screws, chassis	M6	10 Nm (7.4 lbf ft)
---------------------------	----	--------------------

- Position the brake line, wiring harness, and clamp. Mount and tighten screws ③.

### Finishing work

- Install the Powerpack HV. (📖 p. 109)
- Lock the seat. (📖 p. 69)



## 13.6 Cleaning the dust boots of the fork legs

### Preparatory work

- Deactivate the vehicle. (📖 p. 43)
- Fold the seat up. (📖 p. 69)
- Remove the Powerpack HV. (📖 p. 108)
- Mount the protection cap. (📖 p. 71)
- Raise the motorcycle with a lift stand. (📖 p. 57)
- Remove the fork protector. (📖 p. 58)

### Main work

- Push dust boots ① of both fork legs downward.

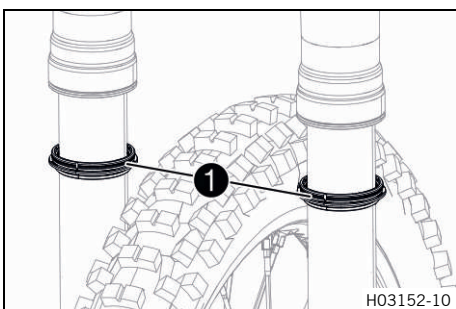

### Info

The dust boots remove dust and coarse dirt particles from the inside fork tubes. Over time, dirt can accumulate behind the dust boots. If this dirt is not removed, the oil seals behind the dust boots can start to leak.



### Warning

**Danger of accidents** Oil or grease on the brake discs reduces the braking effect.

- Always keep the brake discs free of oil and grease.
- Clean the brake discs with brake cleaner when necessary.

- Clean and oil the dust boots and inside fork tubes of both fork legs.

Universal oil spray (📖 p. 145)

- Press the dust boots back into the installation position.
- Remove the excess oil.

### Finishing work

- Install the fork protector. (📖 p. 59)
- Remove the motorcycle from the lift stand. (📖 p. 57)
- Install the Powerpack HV. (📖 p. 109)
- Lock the seat. (📖 p. 69)

## 13.7 Removing the fork legs 🛠️

### Preparatory work

- Deactivate the vehicle. (📖 p. 43)
- Fold the seat up. (📖 p. 69)
- Remove the Powerpack HV. (📖 p. 108)
- Mount the protection cap. (📖 p. 71)
- Raise the motorcycle with a lift stand. (📖 p. 57)
- Remove the front wheel. 🛠️ (📖 p. 91)
- Remove the headlight mask with the headlight. (📖 p. 102)

### Main work

- Remove screws ❶ and take off the clamp.
- Remove the cable tie(s) and disconnect plug-in connector.
- Remove screws ❷ and take off the brake caliper.
- Allow the brake caliper and the brake line to hang loosely to the side.
- Loosen screws ❸. Take out the left fork leg.
- Loosen screws ❹. Take out the right fork leg.

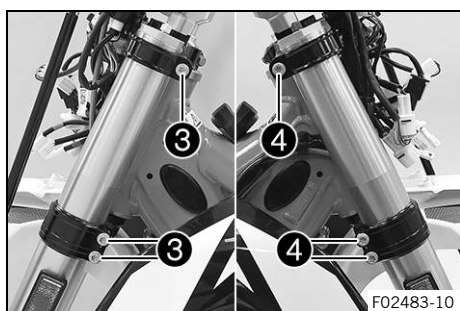
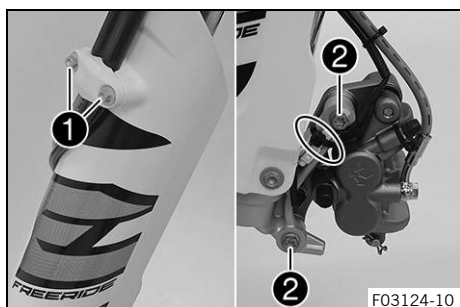

## 13.8 Installing the fork legs

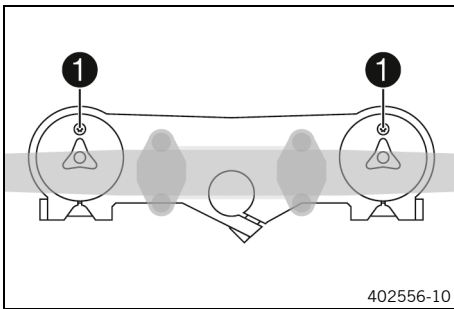

### Main work

- Position the fork legs.
- ✓ Bleeder screws **1** are positioned toward the front.



### Info

Grooves are milled into the side of the upper end of the fork legs. The second milled groove (from the top) must be flush with the upper edge of the upper triple clamp.

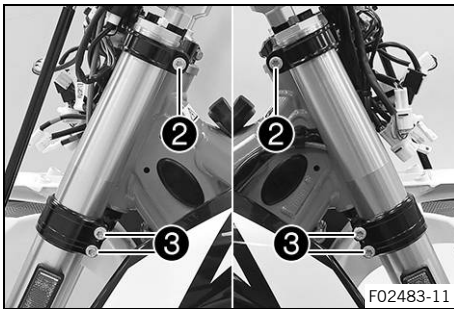

- Tighten screws **2**.

### Guideline

Screw, top triple clamp	M8	22 Nm (16.2 lbf ft)
-------------------------	----	---------------------

- Tighten screws **3**.

### Guideline

Screw, bottom triple clamp	M8	18 Nm (13.3 lbf ft)
----------------------------	----	---------------------

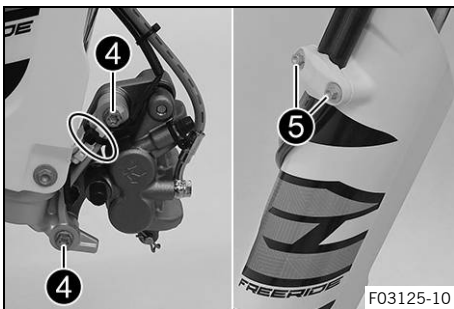

- Position the brake caliper. Mount and tighten screws **4**.

### Guideline

Screw, front brake caliper	M8	25 Nm (18.4 lbf ft) <b>Loctite®243™</b>
----------------------------	----	--

- Position the brake line, the wiring harness, and the clamp. Mount and tighten screws **5**.
- Join plug-in connector and mount the cable tie(s).

### Finishing work

- Install the front wheel. (📖 p. 91)
- Install the headlight mask with the headlight. (📖 p. 102)
- Install the Powerpack HV. (📖 p. 109)
- Lock the seat. (📖 p. 69)
- Check the headlight setting. (📖 p. 105)

## 13.9 Removing the lower triple clamp

### Preparatory work

- Deactivate the vehicle. (📖 p. 43)
- Fold the seat up. (📖 p. 69)
- Remove the Powerpack HV. (📖 p. 108)
- Mount the protection cap. (📖 p. 71)
- Raise the motorcycle with a lift stand. (📖 p. 57)
- Remove the front wheel. (📖 p. 91)
- Remove the headlight mask with the headlight. (📖 p. 102)
- Remove front fender. (📖 p. 66)
- Remove the fork legs. (📖 p. 60)

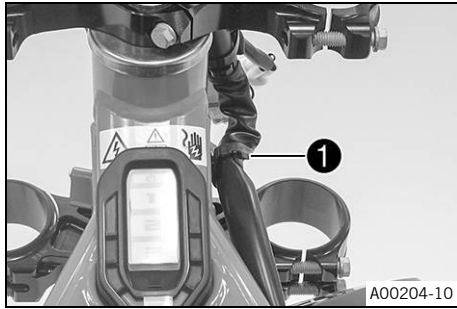

### Main work

- Open holder **1** and detach the wiring harness and brake line.

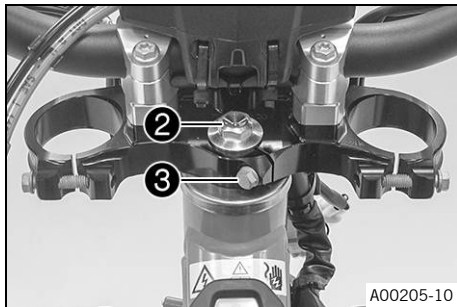

- Remove screw **2**.
- Remove screw **3**.
- Take off the upper triple clamp with the handlebar and set it aside.



### Info

Cover the components to protect them against damage. Do not kink the cables and lines.

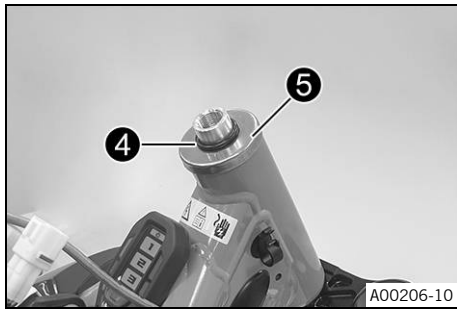

- Remove O-ring **4** and protective ring **5**.
- Take off the lower triple clamp with the steering stem.
- Remove the upper steering head bearing.

## 13.10 Installing the lower triple clamp ↗

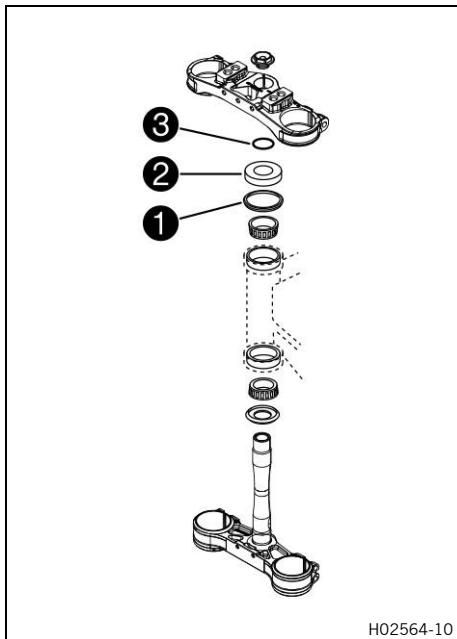

### Main work

- Clean the bearing and sealing elements, check for damage, and grease.

High viscosity grease (📖 p. 145)

- Insert the lower triple clamp with the steering stem. Mount upper steering head bearing.
- Check whether upper steering head seal **1** is correctly positioned.
- Push protective ring **2** and O-ring **3** onto the steering stem.





- Position the upper triple clamp with the handlebar.
- Mount screw ④, but do not tighten yet.
- Position the rear wheel brake line and wiring harness.

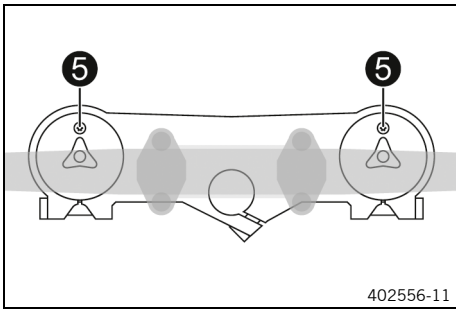

- Position the fork legs.
- ✓ Bleeder screws ⑤ face forwards.

**i Info**  
 The rebound damping is located in right fork leg **REB** (red adjusting screw). The compression damping is located in left fork leg **COM** (white adjusting screw). Grooves are milled into the side of the upper end of the fork legs. The second milled groove (from the top) must be flush with the upper edge of the upper triple clamp.

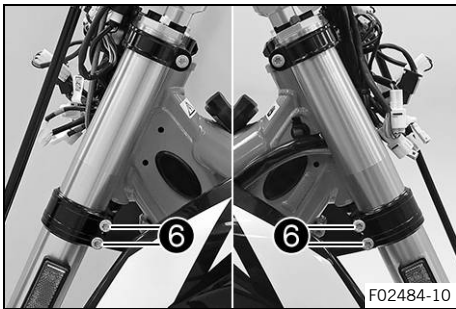

- Tighten screws ⑥.

Guideline

Screw, bottom triple clamp	M8	18 Nm (13.3 lbf ft)
----------------------------	----	---------------------



- Tighten screw ④.

Guideline

Screw, top steering head	M20x1.5	12 Nm (8.9 lbf ft)
--------------------------	---------	--------------------



- Mount and tighten screw ⑦.

Guideline

Screw, top steering stem	M8	17 Nm (12.5 lbf ft) <b>Loctite®243™</b>
--------------------------	----	--

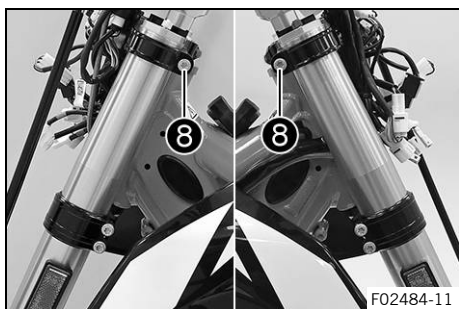

- Tighten screws 8.

Guideline

Screw, top triple clamp	M8	22 Nm (16.2 lbf ft)
-------------------------	----	---------------------



- Attach the brake line and wiring harness. Close holder 9.

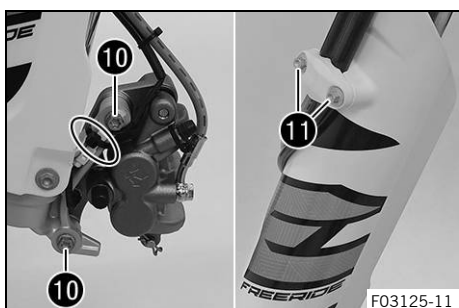

- Position the brake caliper. Mount and tighten screws 10.

Guideline

Screw, front brake caliper	M8	25 Nm (18.4 lbf ft) <b>Loctite®243™</b>
----------------------------	----	--

- Position the brake line, the wiring harness, and the clamp. Mount and tighten screws 11.
- Join plug-in connector and mount the cable tie(s).

### Finishing work

- Install front fender. (📖 p. 67)
- Install the headlight mask with the headlight. (📖 p. 102)
- Install the front wheel. 🛠️ (📖 p. 91)
- Check that the cable and brake lines are routed correctly.
- Check steering head bearing play. 🛠️ (📖 p. 64)
- Remove the motorcycle from the lift stand. (📖 p. 57)
- Install the Powerpack HV. (📖 p. 109)
- Lock the seat. (📖 p. 69)
- Check the headlight setting. (📖 p. 105)

## 13.11 Checking steering head bearing play 🛠️



### Warning

**Danger of accidents** Incorrect steering head bearing play impairs the handling characteristic and damages components.

- Correct incorrect steering head bearing play immediately. (Your authorized KTM workshop will be glad to help.)

**i Info**

If the vehicle is operated for a lengthy period with play in the steering head bearing, the bearings and the bearing seats in the frame can become damaged over time.

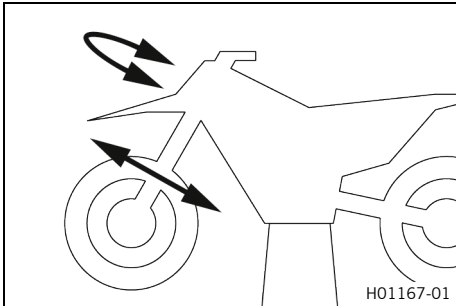

**Preparatory work**

- Deactivate the vehicle. (📖 p. 43)
- Fold the seat up. (📖 p. 69)
- Remove the Powerpack HV. (📖 p. 108)
- Mount the protection cap. (📖 p. 71)
- Raise the motorcycle with a lift stand. (📖 p. 57)

**Main work**

- Move the handlebar to the straight-ahead position. Move the fork legs to and fro in the direction of travel.

Play should not be detectable on the steering head bearing.

- » If there is detectable play:
  - Adjust steering head bearing play. 🛠️ (📖 p. 65)
- Move the handlebar to and fro over the entire steering range.

It must be possible to move the handlebar easily over the entire steering range. There should be no detectable detent positions.

- » If detent positions are detected:
  - Adjust steering head bearing play. 🛠️ (📖 p. 65)
- » If detent positions can still be detected:
  - Change the steering head bearing. 🛠️

**Finishing work**

- Remove the motorcycle from the lift stand. (📖 p. 57)
- Install the Powerpack HV. (📖 p. 109)
- Lock the seat. (📖 p. 69)

**13.12 Adjusting steering head bearing play 🛠️**

**Preparatory work**

- Deactivate the vehicle. (📖 p. 43)
- Fold the seat up. (📖 p. 69)
- Remove the Powerpack HV. (📖 p. 108)
- Mount the protection cap. (📖 p. 71)
- Raise the motorcycle with a lift stand. (📖 p. 57)

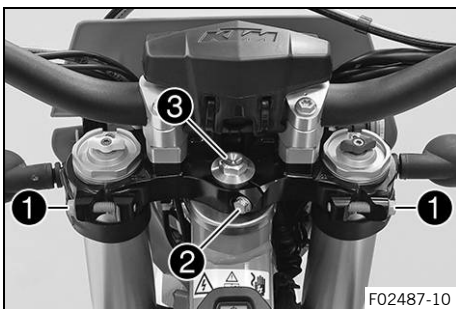

**Main work**

- Loosen screws ❶. Remove screw ❷.
- Loosen and retighten screw ❸.

**Guideline**

Screw, top steering head	M20x1.5	12 Nm (8.9 lbf ft)
--------------------------	---------	--------------------

- Using a plastic hammer, tap lightly on the upper triple clamp to avoid stresses.
- Tighten screws ❶.

## Guideline

Screw, top triple clamp	M8	22 Nm (16.2 lbf ft)
-------------------------	----	---------------------

- Mount and tighten screw ②.

## Guideline

Screw, top steering stem	M8	17 Nm (12.5 lbf ft) <b>Loctite®243™</b>
--------------------------	----	--

## Finishing work

- Check steering head bearing play. 🛠️ (📖 p. 64)
- Remove the motorcycle from the lift stand. (📖 p. 57)
- Install the Powerpack HV. (📖 p. 109)
- Lock the seat. (📖 p. 69)

### 13.13 Greasing the steering head bearing 🛠️

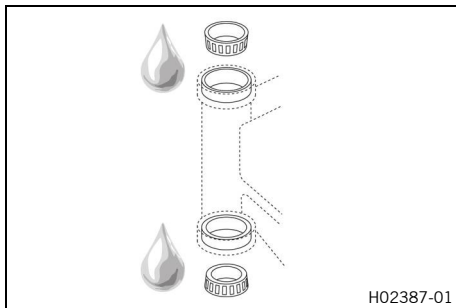

- Remove the lower triple clamp. 🛠️ (📖 p. 61)
- Install the lower triple clamp. 🛠️ (📖 p. 62)

### 13.14 Removing front fender

#### Preparatory work

- Deactivate the vehicle. (📖 p. 43)
- Fold the seat up. (📖 p. 69)
- Remove the Powerpack HV. (📖 p. 108)
- Mount the protection cap. (📖 p. 71)
- Remove the headlight mask with the headlight. (📖 p. 102)

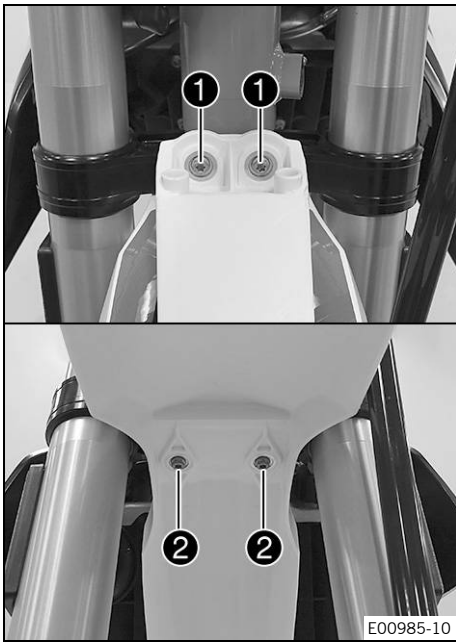

### Main work

- Remove screws ①.
- Remove screws ②.
- Take off the front fender.



## 13.15 Installing front fender

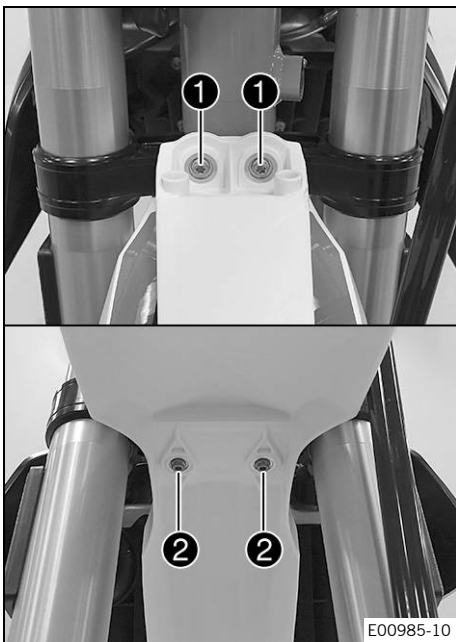

### Main work

- Position front fender. Mount and tighten screws ①.

#### Guideline

Remaining screws, chassis	M6	10 Nm (7.4 lbf ft)
---------------------------	----	--------------------

- Mount and tighten screws ②.

#### Guideline

Remaining screws, chassis	M6	10 Nm (7.4 lbf ft)
---------------------------	----	--------------------

### Finishing work

- Install the headlight mask with the headlight. (📖 p. 102)
- Install the Powerpack HV. (📖 p. 109)
- Lock the seat. (📖 p. 69)
- Check the headlight setting. (📖 p. 105)



## 13.16 Removing the shock absorber ↗

### Preparatory work

- Deactivate the vehicle. (📖 p. 43)
- Fold the seat up. (📖 p. 69)
- Remove the Powerpack HV. (📖 p. 108)
- Mount the protection cap. (📖 p. 71)
- Raise the motorcycle with a lift stand. (📖 p. 57)

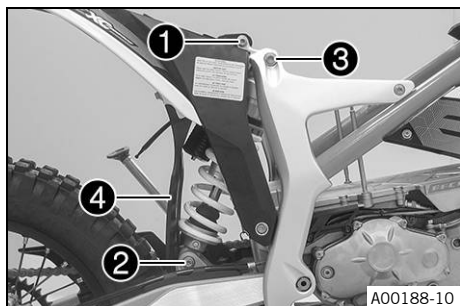

### Main work

- Remove screw ①.
- Remove screw ② and lower the rear wheel with the link fork as far as possible without blocking the rear wheel. Secure the rear wheel in this position.
- Remove screw ③.
- Push splash protector ④ to the side and remove the shock absorber.

## 13.17 Installing the shock absorber ↗

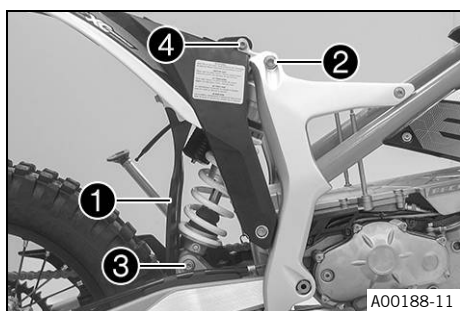

### Main work

- Push splash protector ① to the side and position the shock absorber.
- Mount and tighten screw ②.

#### Guideline

Screw, top shock absorber	M12	80 Nm (59 lbf ft) <b>Loctite®2701™</b>
---------------------------	-----	---

- Mount and tighten screw ③.

#### Guideline

Screw, bottom shock absorber	M12	80 Nm (59 lbf ft) <b>Loctite®2701™</b>
------------------------------	-----	---

### Info

The heim joint for the shock absorber on the link fork is Teflon coated. It must not be lubricated with grease, nor with any other lubricants. Lubricants dissolve the Teflon coating, thereby drastically reducing the service life.

- Mount and tighten screw ④.

#### Guideline

Screw, sub-frame top	M10	45 Nm (33.2 lbf ft) <b>Loctite®243™</b>
----------------------	-----	--

### Finishing work

- Remove the motorcycle from the lift stand. (📖 p. 57)
- Install the Powerpack HV. (📖 p. 109)
- Lock the seat. (📖 p. 69)

## 13.18 Folding the seat up



- Push the release lever ❶ in the direction of the arrow.
- Lift the seat and fold it up.



## 13.19 Locking the seat

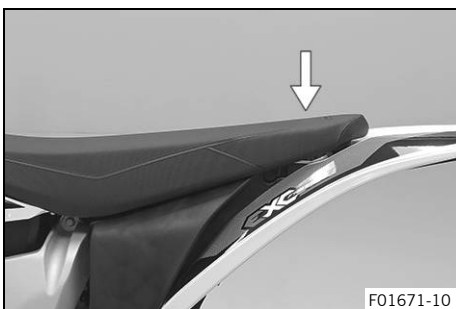

- Fold down the seat and push it down.
- ✓ The seat engages with an audible click.
- Finally, check that the seat is correctly locked.



## 13.20 Removing the spoiler

### Preparatory work

- Deactivate the vehicle. (📖 p. 43)
- Fold the seat up. (📖 p. 69)
- Remove the Powerpack HV. (📖 p. 108)
- Mount the protection cap. (📖 p. 71)

### Main work

- Remove screws ❶.

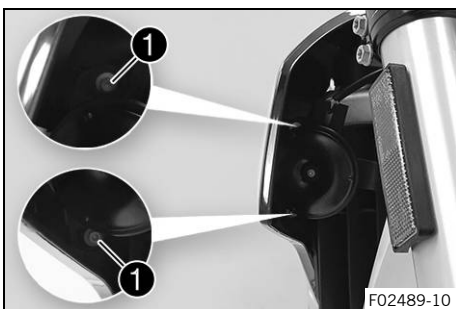

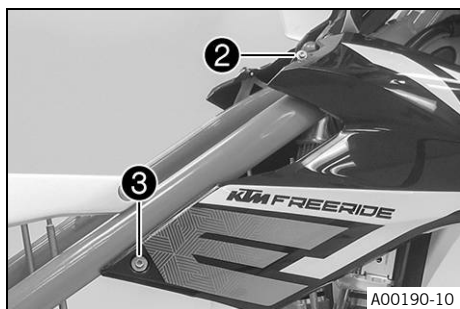

- Remove screw ②.
- Remove screw ③.
- Take off the spoiler.
- Repeat the operation on the opposite side.

## 13.21 Installing the spoiler

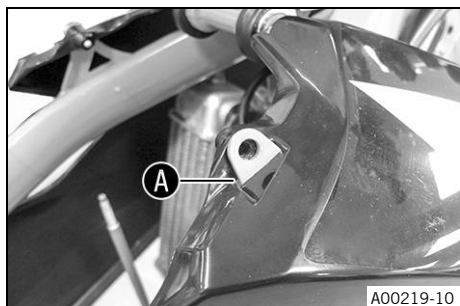

### Main work

- Position the spoiler and hook it in at area A.

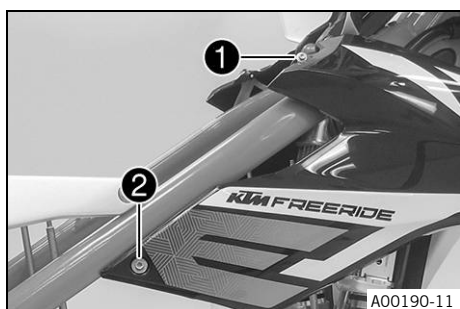

- Mount and tighten screw ①.

### Guideline

Screw, spoiler	<b>EJOT PT®</b> K60x20AL	2 Nm (1.5 lbf ft)
----------------	-----------------------------	-------------------

- Mount and tighten screw ②.

### Guideline

Screw for spoiler attachment	M6	6 Nm (4.4 lbf ft)
------------------------------	----	-------------------

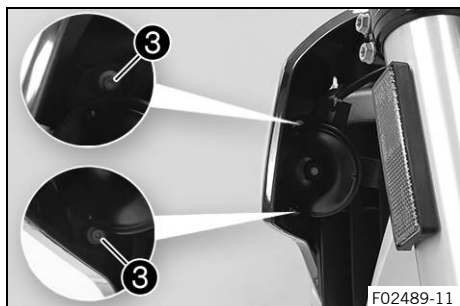

- Mount and tighten screws ③.

### Guideline

Screw, spoiler	<b>EJOT PT®</b> K60x20AL	2 Nm (1.5 lbf ft)
----------------	-----------------------------	-------------------

- Repeat these steps on the opposite side.

### Finishing work

- Install the Powerpack HV. (📖 p. 109)
- Lock the seat. (📖 p. 69)



### 13.22 Mounting the protection cap

#### Note

**Material damage** Components damaged or destroyed by water or dirt.

- Mount the protection cap after you have removed the Powerpack HV.

#### Preparatory work

- Deactivate the vehicle. (📖 p. 43)
- Fold the seat up. (📖 p. 69)
- Remove the Powerpack HV. (📖 p. 108)

#### Main work

- Check the battery discharge plug form ring. (📖 p. 71)
- Mount protection cap ❶ with one hand.

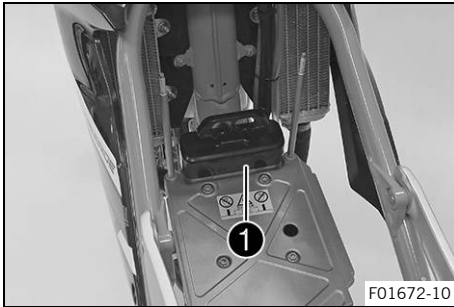

### 13.23 Removing the protection cap

#### Note

**Material damage** Components damaged or destroyed by water or dirt.

- Mount the protection cap after you have removed the Powerpack HV.

#### Main work

- Remove protection cap ❶ with one hand.

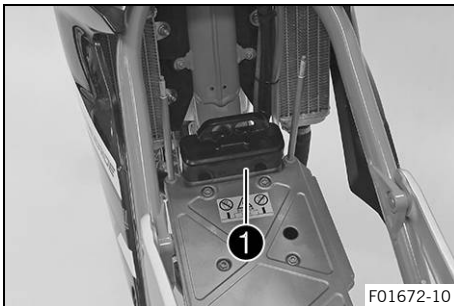

#### Finishing work

- Install the Powerpack HV. (📖 p. 109)
- Lock the seat. (📖 p. 69)

### 13.24 Checking the battery discharge plug form ring

#### Condition

The Powerpack HV is removed.

The protection cap has been removed.

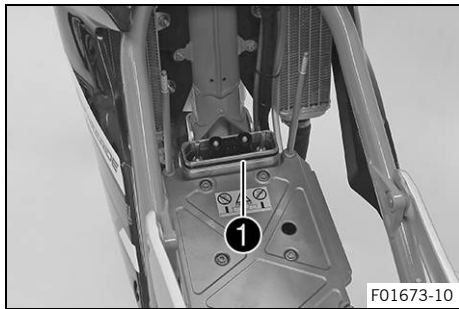

- Check battery discharge plug form ring ① on the electric motor.
  - » If the battery discharge plug form ring is dirty:
    - Ascertain that the discharge plug is at zero potential. 🛡️
    - Clean the form ring without using water or compressed air.
    - Cover the contacts and spray silicone spray onto the form ring.
  - » If the battery discharge plug form ring is damaged:
    - Change the battery discharge plug form ring. 🛡️

## 13.25 Checking for chain dirt accumulation

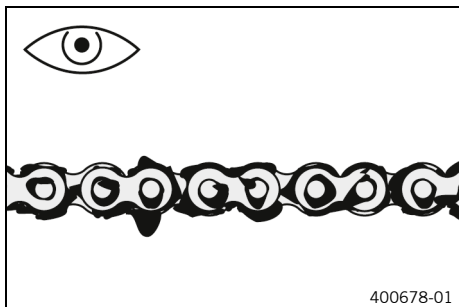

- Check the chain for coarse dirt accumulation.
  - » If the chain is very dirty:
    - Clean the chain. (📖 p. 72)

## 13.26 Cleaning the chain



### Warning

**Danger of accidents** Lubricants on the tires reduces the road grip.

- Remove lubricants from the tires using a suitable cleaning agent.



### Warning

**Danger of accidents** Oil or grease on the brake discs reduces the braking effect.

- Always keep the brake discs free of oil and grease.
- Clean the brake discs with brake cleaner when necessary.



### Note

**Environmental hazard** Hazardous substances cause environmental damage.

- Dispose of oils, grease, cleaning agents, brake fluid etc. properly and in compliance with the applicable regulations.



### Info

The service life of the chain depends largely on its maintenance.

### Preparatory work

- Deactivate the vehicle. (📖 p. 43)
- Fold the seat up. (📖 p. 69)
- Remove the Powerpack HV. (📖 p. 108)
- Mount the protection cap. (📖 p. 71)
- Raise the motorcycle with a lift stand. (📖 p. 57)

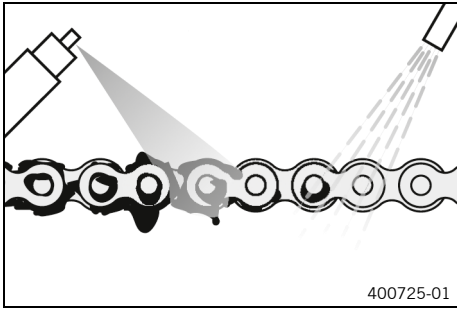

### Main work

- Rinse off loose dirt with a soft jet of water.
- Remove old grease residue with chain cleaner.

Chain cleaner (📖 p. 145)

- After drying, apply chain spray.

Off-road chain spray (📖 p. 145)

### Finishing work

- Remove the motorcycle from the lift stand. (📖 p. 57)
- Install the Powerpack HV. (📖 p. 109)
- Lock the seat. (📖 p. 69)



## 13.27 Checking the chain tension



### Warning

**Danger of accidents** Incorrect chain tension damages components and results in accidents.

If the chain is tensioned too much, the chain, engine sprocket, rear sprocket, transmission and rear wheel bearings wear more quickly. Some components may break if overloaded.

If the chain is too loose, the chain may fall off the engine sprocket or the rear sprocket. As a result, the rear wheel locks or the motor will be damaged.

- Check the chain tension regularly.
- Set the chain tension in accordance with the specification.

### Preparatory work

- Deactivate the vehicle. (📖 p. 43)
- Fold the seat up. (📖 p. 69)
- Remove the Powerpack HV. (📖 p. 108)
- Mount the protection cap. (📖 p. 71)
- Raise the motorcycle with a lift stand. (📖 p. 57)

### Main work

- Pull the chain at the end of the chain sliding piece upward to measure chain tension **A**.

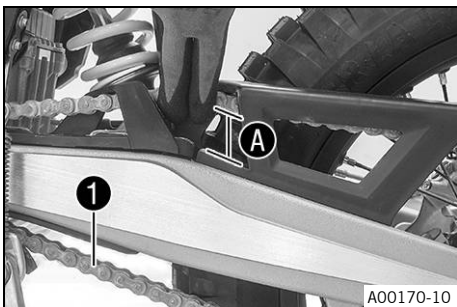

### Info

Lower chain section **1** must be taut.

Chain wear is not always even, so you should repeat this measurement at different chain positions.

Chain tension	36 ... 40 mm (1.42 ... 1.57 in)
---------------	---------------------------------

- » If the chain tension does not meet the specification:
  - Adjust the chain tension. 🛠️ (📖 p. 74)

### Finishing work

- Remove the motorcycle from the lift stand. (📖 p. 57)
- Install the Powerpack HV. (📖 p. 109)
- Lock the seat. (📖 p. 69)



## 13.28 Adjusting the chain tension



### Warning

**Danger of accidents** Incorrect chain tension damages components and results in accidents.

If the chain is tensioned too much, the chain, engine sprocket, rear sprocket, transmission and rear wheel bearings wear more quickly. Some components may break if overloaded.

If the chain is too loose, the chain may fall off the engine sprocket or the rear sprocket. As a result, the rear wheel locks or the motor will be damaged.

- Check the chain tension regularly.
- Set the chain tension in accordance with the specification.

### Preparatory work

- Deactivate the vehicle. (📖 p. 43)
- Fold the seat up. (📖 p. 69)
- Remove the Powerpack HV. (📖 p. 108)
- Mount the protection cap. (📖 p. 71)
- Raise the motorcycle with a lift stand. (📖 p. 57)
- Check the chain tension. (📖 p. 73)

### Main work

- Loosen nut **1**.
- Loosen nuts **2**.
- Adjust the chain tension by turning adjusting screws **3** left and right.

#### Guideline

Chain tension	36 ... 40 mm (1.42 ... 1.57 in)
---------------	---------------------------------

Turn adjusting screws **3** on the left and right so that the markings on the left and right chain adjusters are in the same position relative to reference marks **A**. The rear wheel is then correctly aligned.

- Tighten nuts **2**.
- Make sure that chain adjusters **4** are fitted correctly on adjusting screws **3**.
- Tighten nut **1**.

#### Guideline

Nut, rear wheel spindle	M20x1.5	80 Nm (59 lbf ft)
-------------------------	---------	-------------------

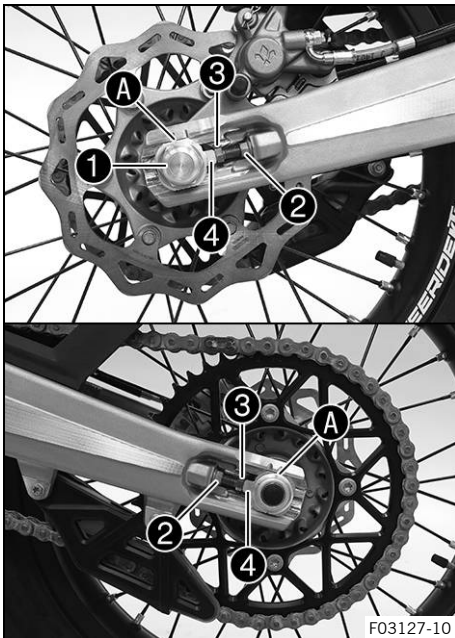

F03127-10



### Info

The wide adjustment range of the chain adjusters enables different secondary ratios with the same chain length.

Chain adjusters **4** can be turned by 180°.

### Finishing work

- Remove the motorcycle from the lift stand. (📖 p. 57)
- Install the Powerpack HV. (📖 p. 109)
- Lock the seat. (📖 p. 69)

## 13.29 Checking the chain, rear sprocket, engine sprocket, and chain guide

### Preparatory work

- Deactivate the vehicle. (📖 p. 43)
- Fold the seat up. (📖 p. 69)
- Remove the Powerpack HV. (📖 p. 108)
- Mount the protection cap. (📖 p. 71)
- Raise the motorcycle with a lift stand. (📖 p. 57)

### Main work

- Check the chain, rear sprocket and engine sprocket for wear.
  - » If the chain, rear sprocket or engine sprocket is worn:
    - Change the drivetrain kit. 🛠️

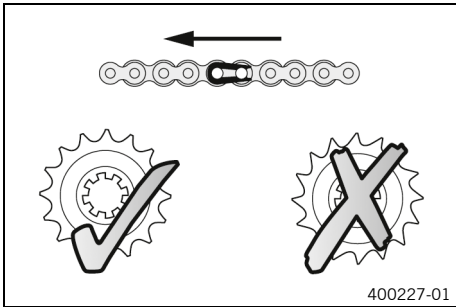

### **i** Info

The engine sprocket, rear sprocket and chain should always be replaced together.

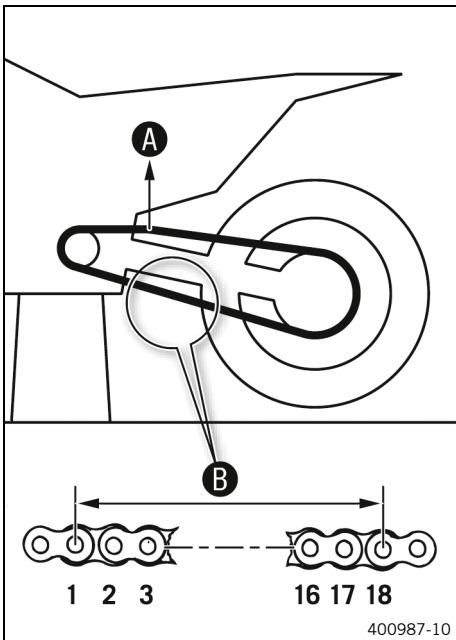

- Pull on the top section of the chain with the specified weight **A**.

### Guideline

Weight, chain wear measurement	10 ... 15 kg (22 ... 33 lb.)
--------------------------------	------------------------------

- Measure distance **B** of 18 chain rollers in the lower chain section.

### **i** Info

Chain wear is not always even, so you should repeat this measurement at different chain positions.

Maximum distance <b>B</b> from 18 chain rollers at the longest chain section	272 mm (10.71 in)
--	-------------------

- » If distance **B** is greater than the specified measurement:
  - Change the drivetrain kit. 🛠️

### **i** Info

The engine sprocket, rear sprocket and chain should always be replaced together.

# 13 SERVICE WORK ON THE CHASSIS

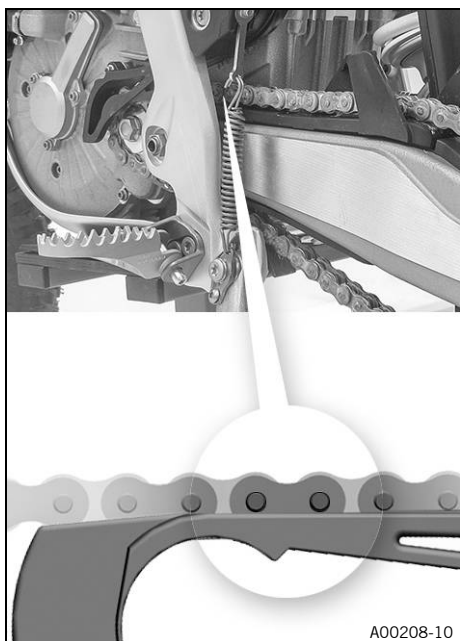

- Check the chain sliding guard for wear.
  - » If the lower edge of the chain pins is in line with, or below, the chain sliding guard:
    - Change the chain sliding guard. 🛠️
- Check that the chain sliding guard is firmly seated.
  - » If the chain sliding guard is loose:
    - Tighten the screws on the chain sliding guard.

Guideline

Remaining screws, chassis	M6	10 Nm (7.4 lbf ft)
---------------------------	----	-----------------------



- Check the chain sliding piece for wear.
  - » If the lower edge of the chain pins is in line with or below the chain sliding piece:
    - Change the chain sliding piece. 🛠️
- Check that the chain sliding piece is firmly seated.
  - » If the chain sliding piece is loose:
    - Tighten the screw on the chain sliding piece.

Guideline

Screw, chain sliding piece	M8	15 Nm (11.1 lbf ft)
----------------------------	----	------------------------

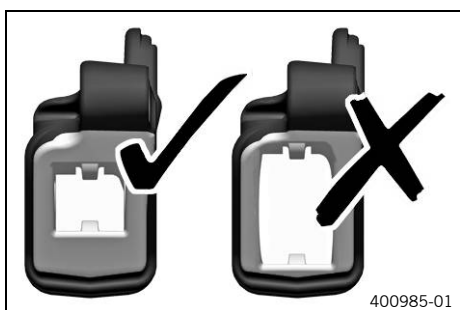

- Check the chain guide for wear.

**i Info**

Wear can be seen on the front of the chain guide.

- » If the light part of the chain guide is worn:
  - Change the chain guide. 🛠️



- Check that the chain guide is firmly seated.
  - » If the chain guide is loose:
    - Tighten the fitting on the chain guide.

Guideline

Remaining screws, chassis	M6	10 Nm (7.4 lbf ft)
Remaining nuts, chassis	M6	10 Nm (7.4 lbf ft)

**Finishing work**

- Remove the motorcycle from the lift stand. (📖 p. 57)
- Install the Powerpack HV. (📖 p. 109)
- Lock the seat. (📖 p. 69)



## 13.30 Checking the frame 🛠️

**Preparatory work**

- Deactivate the vehicle. (📖 p. 43)
- Fold the seat up. (📖 p. 69)
- Remove the Powerpack HV. (📖 p. 108)
- Mount the protection cap. (📖 p. 71)

**Main work**

- Check the frame for damage, cracking, and deformation.
  - » If the frame shows signs of damage, cracking, or deformation:
    - Change the frame. 🛠️

Guideline

Repairs on the frame are not permitted.
---



**Finishing work**

- Install the Powerpack HV. (📖 p. 109)
- Lock the seat. (📖 p. 69)



## 13.31 Checking the link fork 🛠️

**Preparatory work**

- Deactivate the vehicle. (📖 p. 43)
- Fold the seat up. (📖 p. 69)
- Remove the Powerpack HV. (📖 p. 108)
- Mount the protection cap. (📖 p. 71)



### Main work

- Check the link fork for damage, cracking, and deformation.
  - » If the link fork exhibits damage, cracking, or deformation:
    - Change the link fork. 🛠️

---

**i Info**  
Always replace a damaged link fork. Repairing the link fork is not authorized by KTM.

---

### Finishing work

- Install the Powerpack HV. (📖 p. 109)
- Lock the seat. (📖 p. 69)

## 13.32 Checking the rubber grip

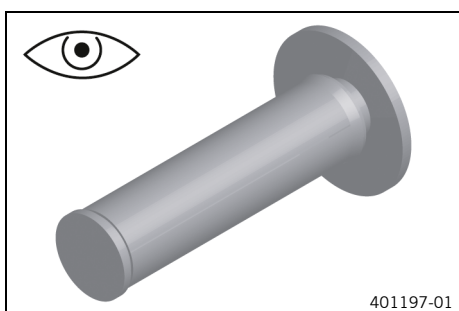

- Check the rubber grips on the handlebar for damage, wear, and looseness.

---

**i Info**  
The rubber grips are vulcanized onto a sleeve on the left and onto the handle tube of the throttle grip on the right. The left sleeve is clamped onto the handlebar. The rubber grip can only be replaced with the sleeve or the throttle tube.

---

- » If a rubber grip is damaged, worn, or loose:
  - Change the rubber grip.
- Check that screw **1** is firmly seated.

### Guideline

Screw, fixed grip	M4	5 Nm (3.7 lbf ft) <b>Loctite®243™</b>
-------------------	----	--

Diamond **A** must be positioned visibly as shown in the figure.

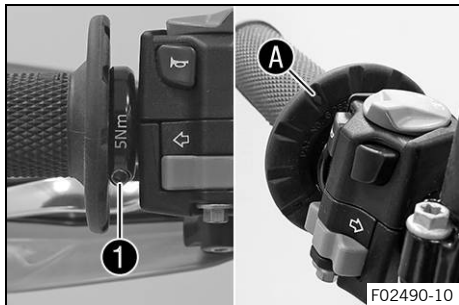



### 14.1 Checking the free travel of the front brake lever



#### Warning

**Danger of accidents** The brake system fails in the event of overheating.

If there is no free travel on the front brake lever, pressure builds up in the brake system on the front brake.

- Set the free travel on the front brake lever in accordance with the specification.

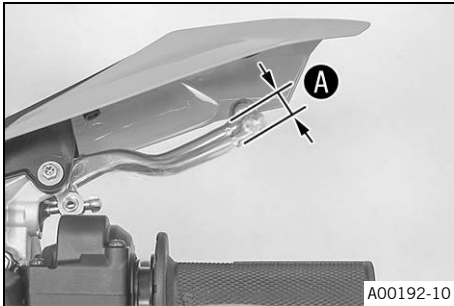

- Push the front brake lever to the handlebar and check free travel **A**.

Free travel of the front brake lever	$\geq 3 \text{ mm } (\geq 0.12 \text{ in})$
--------------------------------------	---

- » If the free travel does not match the specification:
  - Adjust the free travel of the front brake lever. (p. 79)

### 14.2 Adjusting the free travel of the front brake lever

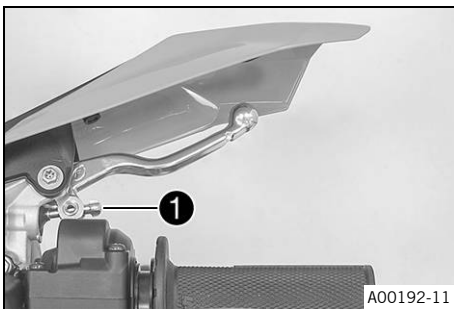

- Adjust the free travel of the front brake lever using adjusting screw **1**.



#### Info

Turn the adjusting screw clockwise to reduce free travel. The pressure point moves away from the handlebar.

Turn the adjusting screw counterclockwise to increase free travel. The pressure point moves towards the handlebar.

The range of adjustment is limited.

Only turn the adjusting screw by hand, and do not use force.

Do not make any adjustments while riding.

### 14.3 Checking the brake discs



#### Warning

**Danger of accidents** Worn-out brake discs reduce the braking effect.

- Make sure that worn-out brake discs are replaced immediately. (Your authorized KTM workshop will be glad to help.)

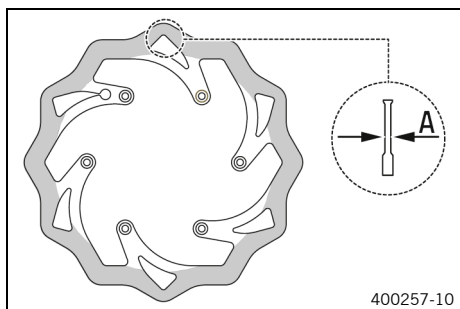

- Check the front and rear brake disc thickness at multiple points for the dimension **A**.

**Info**  
Wear reduces the thickness of the brake disc around the contact surface of the brake linings.

Brake discs - wear limit	
front	3.5 mm (0.138 in)
rear	3.5 mm (0.138 in)

- » If the brake disc thickness is less than the specified value:
  - Change the front brake disc. 🛠️
  - Change the rear brake disc. 🛠️
- Check the front and rear brake discs for damage, cracking, and deformation.
  - » If the brake disc exhibits damage, cracking, or deformation:
    - Change the front brake disc. 🛠️
    - Change the rear brake disc. 🛠️

## 14.4 Checking the front brake fluid level



### Warning

**Danger of accidents** An insufficient brake fluid level will cause the brake system to fail.

If the brake fluid level drops below the **MIN** marking, the brake system is leaking or the brake linings are worn down.

- Check the brake system and do not continue riding until the problem is eliminated. (Your authorized KTM workshop will be glad to help.)



### Warning

**Danger of accidents** Old brake fluid reduces the braking effect.

- Make sure that brake fluid for the front and rear brake is changed in accordance with the service schedule. (Your authorized KTM workshop will be glad to help.)

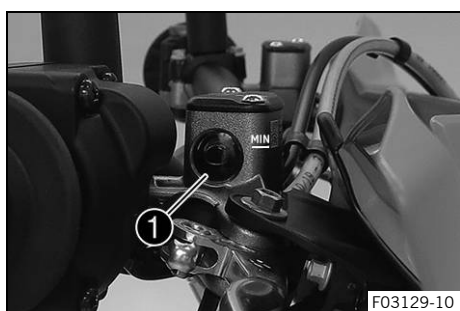

- Move the brake fluid reservoir attached to the right of the handlebar to a horizontal position.
- Check the brake fluid level in level viewer **1**.
  - » If the brake fluid level is below the **MIN** marking:
    - Add front brake fluid. 🛠️ (📖 p. 81)

## 14.5 Adding front brake fluid



### Warning

**Danger of accidents** An insufficient brake fluid level will cause the brake system to fail.

If the brake fluid level drops below the **MIN** marking, the brake system is leaking or the brake linings are worn down.

- Check the brake system and do not continue riding until the problem is eliminated. (Your authorized KTM workshop will be glad to help.)



### Warning

**Skin irritation** Brake fluid causes skin irritation.

- Keep brake fluid out of the reach of children.
- Wear suitable protective clothing and safety glasses.
- Do not allow brake fluid to come into contact with the skin, the eyes or clothing.
- Consult a doctor immediately if brake fluid has been swallowed.
- Rinse the affected area with plenty of water in the event of contact with the skin.
- Rinse eyes thoroughly with water immediately and consult a doctor if brake fluid comes into contact with the eyes.
- If brake fluid spills on to your clothing, change the clothing.



### Warning

**Danger of accidents** Old brake fluid reduces the braking effect.

- Make sure that brake fluid for the front and rear brake is changed in accordance with the service schedule. (Your authorized KTM workshop will be glad to help.)



### Warning

**Danger of accidents** Unsuitable brake fluid damages the brake system.

DOT 5 brake fluid attacks seals and brake lines. DOT 5 brake fluid is silicone-based and purple in color.

- Do not use DOT 5 brake fluid.



### Note

**Environmental hazard** Hazardous substances cause environmental damage.





- Dispose of oils, grease, cleaning agents, brake fluid etc. properly and in compliance with the applicable regulations.



### Info

Avoid contact between brake fluid and painted parts. Brake fluid corrodes paint. Only use clean brake fluid from a sealed container.

#### Preparatory work

- Deactivate the vehicle. ( p. 43)
- Fold the seat up. ( p. 69)
- Remove the Powerpack HV. ( p. 108)
- Mount the protection cap. ( p. 71)
- Check the front brake linings. ( p. 82)

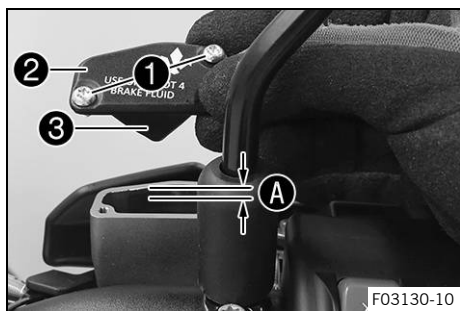

### Main work

- Move the brake fluid reservoir attached to the right of the handlebar to a horizontal position.
- Remove screws ①.
- Take off cover ② with membrane ③.
- Add brake fluid to level A.

### Guideline

Level A (brake fluid level below reservoir rim)	5 mm (0.2 in)
---	---------------

Brake fluid DOT 4 / DOT 5.1 (📖 p. 143)
--

- Position the cover with the membrane. Mount and tighten the screws.

### Info

Use water to immediately clean up any brake fluid that has overflowed or spilled.

### Finishing work

- Install the Powerpack HV. (📖 p. 109)
- Lock the seat. (📖 p. 69)

## 14.6 Checking the front brake linings



### Warning

**Danger of accidents** Worn-out brake linings reduce the braking effect.

- Ensure that worn-out brake linings are replaced immediately. (Your authorized KTM workshop will be glad to help.)

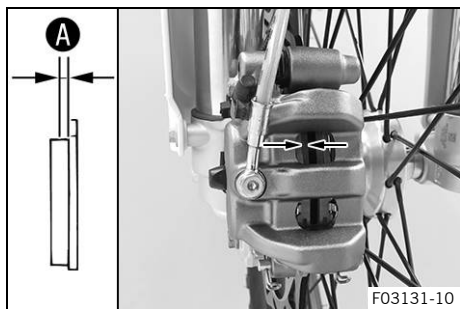

- Check the brake linings for lining thickness A.

Minimum thickness A	$\geq 1 \text{ mm } (\geq 0.04 \text{ in})$
---------------------	---

- » If the minimum thickness is less than specified:
  - Change the brake linings of the front brake. 🛠️ (📖 p. 83)
- Check the brake linings for damage and cracking.
  - » If damage or cracking is visible:
    - Change the brake linings of the front brake. 🛠️ (📖 p. 83)

## 14.7 Changing the brake linings of the front brake



### Warning

**Danger of accidents** Incorrect servicing will cause the brake system to fail.

- Ensure that service work and repairs are performed professionally. (Your authorized KTM workshop will be glad to help.)



### Warning

**Skin irritation** Brake fluid causes skin irritation.

- Keep brake fluid out of the reach of children.
- Wear suitable protective clothing and safety glasses.
- Do not allow brake fluid to come into contact with the skin, the eyes or clothing.
- Consult a doctor immediately if brake fluid has been swallowed.
- Rinse the affected area with plenty of water in the event of contact with the skin.
- Rinse eyes thoroughly with water immediately and consult a doctor if brake fluid comes into contact with the eyes.
- If brake fluid spills on to your clothing, change the clothing.



### Warning

**Danger of accidents** Old brake fluid reduces the braking effect.

- Make sure that brake fluid for the front and rear brake is changed in accordance with the service schedule. (Your authorized KTM workshop will be glad to help.)



### Warning

**Danger of accidents** Oil or grease on the brake discs reduces the braking effect.

- Always keep the brake discs free of oil and grease.
- Clean the brake discs with brake cleaner when necessary.



### Warning

**Danger of accidents** Brake linings which have not been approved alter the braking efficiency.

Not all brake linings are tested and approved for KTM motorcycles. The structure and friction coefficient of the brake linings, and thus their brake power, may vary greatly from that of original brake linings. If brake linings are used that differ from the original equipment, compliance with the original homologation is not guaranteed. In this case, the vehicle no longer corresponds to its condition at delivery and the manufacturer warranty shall be void.

- Only use brake linings approved and recommended by KTM.



### Warning

**Danger of accidents** Unsuitable brake fluid damages the brake system.

DOT 5 brake fluid attacks seals and brake lines. DOT 5 brake fluid is silicone-based and purple in color.

- Do not use DOT 5 brake fluid.



### Note

**Environmental hazard** Hazardous substances cause environmental damage.

- Dispose of oils, grease, cleaning agents, brake fluid etc. properly and in compliance with the applicable regulations.



### Info

Avoid contact between brake fluid and painted parts. Brake fluid corrodes paint. Only use clean brake fluid from a sealed container.



F03130-11

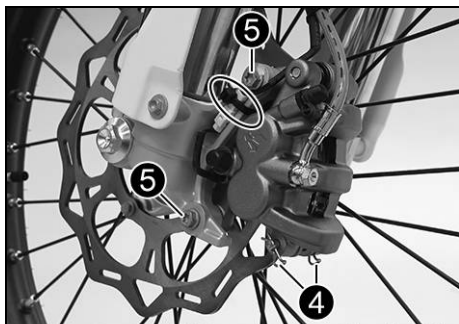

F03132-10

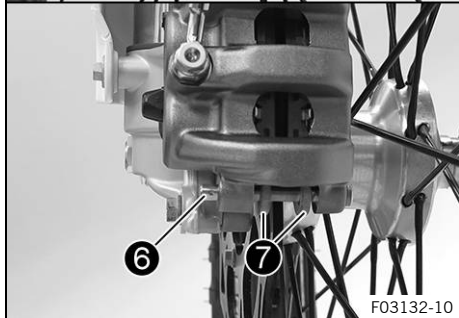

F03132-10

### Preparatory work

- Deactivate the vehicle. (📖 p. 43)
- Fold the seat up. (📖 p. 69)
- Remove the Powerpack HV. (📖 p. 108)
- Mount the protection cap. (📖 p. 71)

### Main work

- Move the brake fluid reservoir attached to the right of the handlebar to a horizontal position.
- Remove screws ①.
- Take off cover ② with membrane ③.

- Remove cotter pin ④.
- Remove the cable tie(s) and disconnect plug-in connector.
- Remove screws ⑤.
- Manually press the brake caliper toward the brake disc to push back the brake pistons. Ensure that brake fluid does not flow out of the brake fluid reservoir; extract some if necessary.

#### **i** Info

Make sure that you do not press the brake caliper against the spokes when pushing back the brake pistons.

- Remove pin ⑥.
- Remove brake linings ⑦ and the retainer spring.
- Press the brake piston back into the basic position and ensure that brake fluid does not flow out of the brake fluid reservoir, extracting some if necessary.
- Clean brake caliper.
- Check the brake discs. (📖 p. 79)
- Position the retainer spring.
- Position the new brake linings.

#### **i** Info

Always change the brake linings in pairs.

- Mount pin ⑥.

#### **i** Info

To make it easier to mount the pin, push the brake linings against the retainer spring. Make sure the brake linings and retainer spring are seated correctly.

- Mount cotter pins ④.
- Position the brake caliper. Mount screws ⑤, but do not tighten yet.

- Operate the front brake lever several times until the brake linings are in contact with the brake disc and there is a pressure point. Secure the front brake lever in the activated position.
  - ✓ The brake caliper straightens.
- Tighten screws ⑤.

Guideline

Screw, front brake caliper	M8	25 Nm (18.4 lbf ft) <b>Loctite®243™</b>
----------------------------	----	--

- Join plug-in connector and mount the cable tie(s).
- Remove the means of securing the front brake lever.
- Correct the brake fluid up to level A.

Guideline

Level A (brake fluid level below reservoir rim)	5 mm (0.2 in)
---	---------------

Brake fluid DOT 4 / DOT 5.1 (📖 p. 143)

- Position cover ② with membrane ③.
- Mount and tighten screws ①.

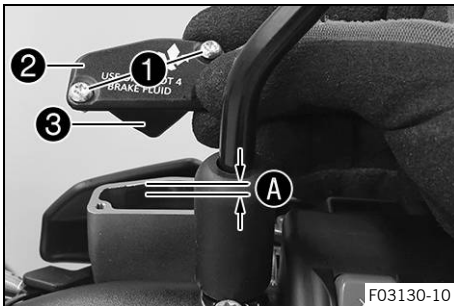

**i Info**  
Use water to immediately clean up any brake fluid that has overflowed or spilled.

### Finishing work

- Install the Powerpack HV. (📖 p. 109)
- Lock the seat. (📖 p. 69)

## 14.8 Checking the free travel of the rear brake lever



### Warning

**Danger of accidents** The brake system fails in the event of overheating.

If there is no free travel on the rear brake lever, pressure builds up in the brake system on the rear brake.

- Set the free travel on the rear brake lever in accordance with the specification.

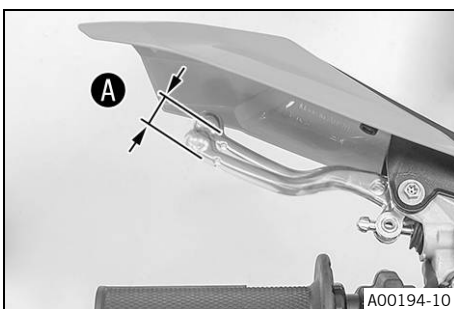

- Push the rear brake lever to the handlebar and check free travel A.

Guideline

Free travel of the rear brake lever	≥ 3 mm (≥ 0.12 in)
-------------------------------------	--------------------

- » If the free travel does not match the specification:
  - Adjust the free travel of the rear brake lever. (📖 p. 86)

## 14.9 Adjusting the free travel of the rear brake lever

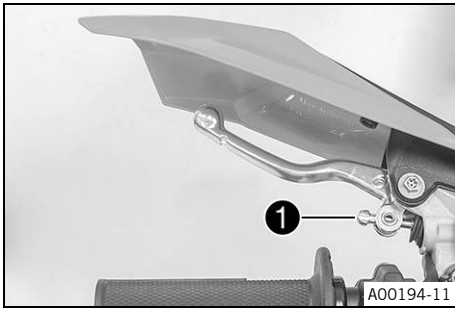

- Adjust the free travel of the rear brake lever using adjusting screw ①.



### Info

Turn the adjusting screw clockwise to reduce free travel. The pressure point moves away from the handlebar.  
Turn the adjusting screw counterclockwise to increase free travel. The pressure point moves towards the handlebar.  
The range of adjustment is limited.  
Only turn the adjusting screw by hand, and do not use force.  
Do not make any adjustments while riding.

## 14.10 Checking the rear brake fluid level



### Warning

**Danger of accidents** An insufficient brake fluid level will cause the brake system to fail.

If the brake fluid level drops below the **MIN** marking, the brake system is leaking or the brake linings are worn down.

- Check the brake system and do not continue riding until the problem is eliminated. (Your authorized KTM workshop will be glad to help.)



### Warning

**Danger of accidents** Old brake fluid reduces the braking effect.

- Make sure that brake fluid for the front and rear brake is changed in accordance with the service schedule. (Your authorized KTM workshop will be glad to help.)



- Move the brake fluid reservoir attached to the left of the handlebar to a horizontal position.
- Check the brake fluid level in level viewer ①.
  - » If the brake fluid level is below the **MIN** marking:
    - Add rear brake fluid. 🛠️ (p. 86)

## 14.11 Adding rear brake fluid 🛠️



### Warning

**Danger of accidents** An insufficient brake fluid level will cause the brake system to fail.

If the brake fluid level drops below the **MIN** marking, the brake system is leaking or the brake linings are worn down.

- Check the brake system and do not continue riding until the problem is eliminated. (Your authorized KTM workshop will be glad to help.)





## Warning

**Skin irritation** Brake fluid causes skin irritation.

- Keep brake fluid out of the reach of children.
- Wear suitable protective clothing and safety glasses.
- Do not allow brake fluid to come into contact with the skin, the eyes or clothing.
- Consult a doctor immediately if brake fluid has been swallowed.
- Rinse the affected area with plenty of water in the event of contact with the skin.
- Rinse eyes thoroughly with water immediately and consult a doctor if brake fluid comes into contact with the eyes.
- If brake fluid spills on to your clothing, change the clothing.



## Warning

**Danger of accidents** Old brake fluid reduces the braking effect.

- Make sure that brake fluid for the front and rear brake is changed in accordance with the service schedule. (Your authorized KTM workshop will be glad to help.)



## Warning

**Danger of accidents** Unsuitable brake fluid damages the brake system.

DOT 5 brake fluid attacks seals and brake lines. DOT 5 brake fluid is silicone-based and purple in color.

- Do not use DOT 5 brake fluid.



## Note

**Environmental hazard** Hazardous substances cause environmental damage.

- Dispose of oils, grease, cleaning agents, brake fluid etc. properly and in compliance with the applicable regulations.



## Info

Avoid contact between brake fluid and painted parts. Brake fluid corrodes paint. Only use clean brake fluid from a sealed container.

### Preparatory work

- Deactivate the vehicle. (📖 p. 43)
- Fold the seat up. (📖 p. 69)
- Remove the Powerpack HV. (📖 p. 108)
- Mount the protection cap. (📖 p. 71)
- Check the rear brake linings. (📖 p. 88)

### Main work

- Move the brake fluid reservoir attached to the left of the handlebar to a horizontal position.
- Remove screws ①.
- Take off cover ② with membrane ③.
- Add brake fluid to level A.

#### Guideline

Level A (brake fluid level below reservoir rim)	5 mm (0.2 in)
---	---------------

Brake fluid DOT 4 / DOT 5.1 (📖 p. 143)

- Position the cover with the membrane. Mount and tighten the screws.

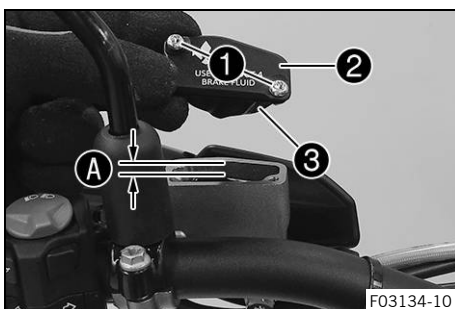

**i Info**

Use water to immediately clean up any brake fluid that has overflowed or spilled.

**Finishing work**

- Install the Powerpack HV. (📖 p. 109)
- Lock the seat. (📖 p. 69)

## 14.12 Checking the rear brake linings



**Warning**

**Danger of accidents** Worn-out brake linings reduce the braking effect.

- Ensure that worn-out brake linings are replaced immediately. (Your authorized KTM workshop will be glad to help.)

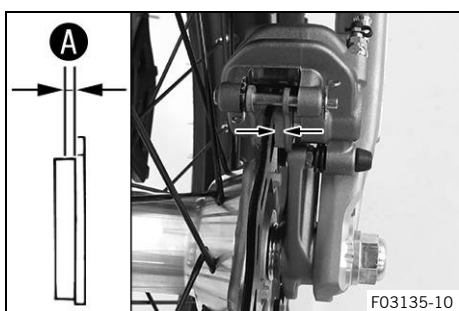

- Check the brake linings for lining thickness **A**.

Minimum thickness <b>A</b>	$\geq 1 \text{ mm } (\geq 0.04 \text{ in})$
----------------------------	---

- » If the minimum thickness is less than specified:
  - Change the rear brake linings. 🛠️ (📖 p. 88)
- Check the brake linings for damage and cracking.
  - » If damage or wear is encountered:
    - Change the rear brake linings. 🛠️ (📖 p. 88)

## 14.13 Changing the rear brake linings 🛠️



**Warning**

**Danger of accidents** Incorrect servicing will cause the brake system to fail.

- Ensure that service work and repairs are performed professionally. (Your authorized KTM workshop will be glad to help.)



**Warning**

**Skin irritation** Brake fluid causes skin irritation.

- Keep brake fluid out of the reach of children.
- Wear suitable protective clothing and safety glasses.
- Do not allow brake fluid to come into contact with the skin, the eyes or clothing.
- Consult a doctor immediately if brake fluid has been swallowed.
- Rinse the affected area with plenty of water in the event of contact with the skin.
- Rinse eyes thoroughly with water immediately and consult a doctor if brake fluid comes into contact with the eyes.
- If brake fluid spills on to your clothing, change the clothing.



**Warning**

**Danger of accidents** Old brake fluid reduces the braking effect.

- Make sure that brake fluid for the front and rear brake is changed in accordance with the service schedule. (Your authorized KTM workshop will be glad to help.)

**Warning**

**Danger of accidents** Oil or grease on the brake discs reduces the braking effect.

- Always keep the brake discs free of oil and grease.
- Clean the brake discs with brake cleaner when necessary.

**Warning**

**Danger of accidents** Brake linings which have not been approved alter the braking efficiency.

Not all brake linings are tested and approved for KTM motorcycles. The structure and friction coefficient of the brake linings, and thus their brake power, may vary greatly from that of original brake linings. If brake linings are used that differ from the original equipment, compliance with the original homologation is not guaranteed. In this case, the vehicle no longer corresponds to its condition at delivery and the manufacturer warranty shall be void.

- Only use brake linings approved and recommended by KTM.

**Warning**

**Danger of accidents** Unsuitable brake fluid damages the brake system.

DOT 5 brake fluid attacks seals and brake lines. DOT 5 brake fluid is silicone-based and purple in color.

- Do not use DOT 5 brake fluid.

**Note**

**Environmental hazard** Hazardous substances cause environmental damage.

- Dispose of oils, grease, cleaning agents, brake fluid etc. properly and in compliance with the applicable regulations.

**Info**

Avoid contact between brake fluid and painted parts. Brake fluid corrodes paint. Only use clean brake fluid from a sealed container.

**Preparatory work**

- Deactivate the vehicle. (📖 p. 43)
- Fold the seat up. (📖 p. 69)
- Remove the Powerpack HV. (📖 p. 108)
- Mount the protection cap. (📖 p. 71)

**Main work**

- Move the brake fluid reservoir attached to the left of the handlebar to a horizontal position.
- Remove screws ❶.
- Take off cover ❷ with membrane ❸.
- Manually press the brake caliper toward the brake disc to push back the brake pistons. Ensure that brake fluid does not flow out of the brake fluid reservoir; extract some if necessary.

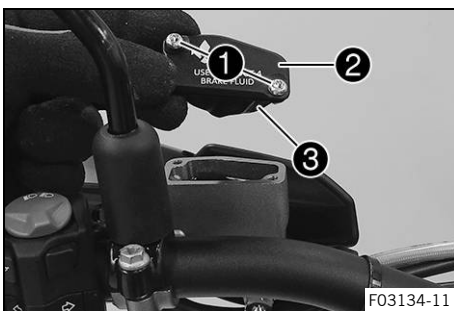
**Info**

Make sure that you do not press the brake caliper against the spokes when pushing back the brake pistons.

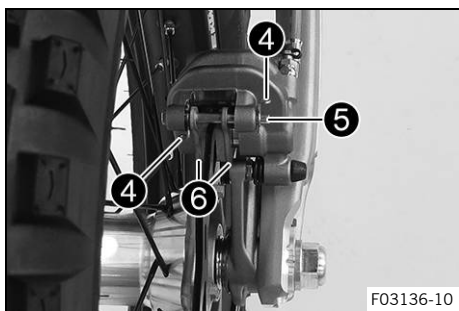

- Remove cotter pin ④.
- Remove pin ⑤.
- Remove brake linings ⑥ and the retainer spring.
- Press the brake piston back into the basic position and ensure that brake fluid does not flow out of the brake fluid reservoir, extracting some if necessary.
- Clean brake caliper.
- Check the brake discs. (📖 p. 79)
- Position the retainer spring.
- Position the new brake linings.



**Info**

Always change the brake linings in pairs.

- Mount pin ⑤.



**Info**

To make it easier to mount the pin, push the brake linings upwards against the retainer spring. Make sure the brake linings and retainer spring are seated correctly.

- Mount cotter pins ④.
- Operate the rear brake lever several times until the brake linings are in contact with the brake disc and there is a pressure point.

- Correct brake fluid level to marking A.

Guideline

Level A (brake fluid level below reservoir rim)	5 mm (0.2 in)
---	---------------

Brake fluid DOT 4 / DOT 5.1 (📖 p. 143)
--

- Mount cover ② with membrane ③.
- Mount and tighten screws ①.

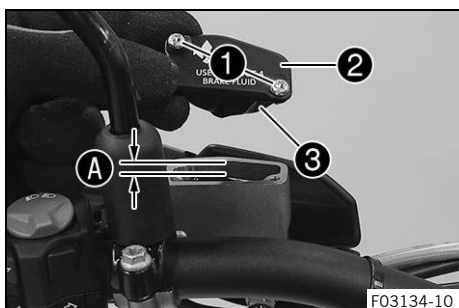

**Info**

Use water to immediately clean up any brake fluid that has overflowed or spilled.

**Finishing work**

- Install the Powerpack HV. (📖 p. 109)
- Lock the seat. (📖 p. 69)

## 15.1 Removing the front wheel ↩

### Preparatory work

- Deactivate the vehicle. (📖 p. 43)
- Fold the seat up. (📖 p. 69)
- Remove the Powerpack HV. (📖 p. 108)
- Mount the protection cap. (📖 p. 71)
- Raise the motorcycle with a lift stand. (📖 p. 57)

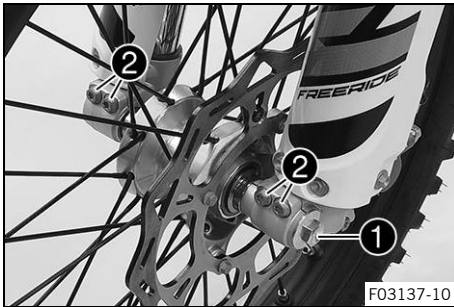

F03137-10

### Main work

- Loosen screw ❶ by several rotations.
- Loosen screws ❷.
- Press on screw ❶ to push the wheel spindle out of the axle clamp.
- Remove screw ❶.

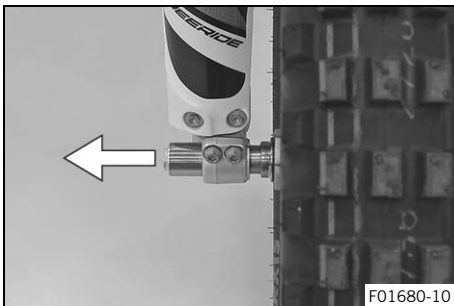

F01680-10



### Warning

**Danger of accidents** Damaged brake discs reduce the braking effect.

- Always lay the wheel down in such a way that the brake disc is not damaged.

- Hold front wheel and remove wheel spindle. Take the front wheel out of the fork.



### Info

Do not operate the front brake lever when the front wheel is removed.

- Remove spacers ❸.

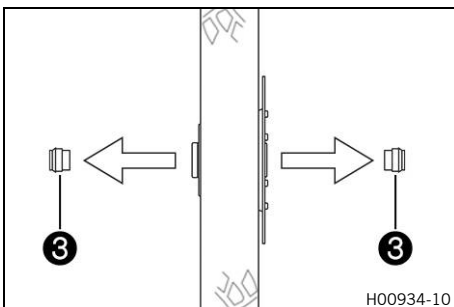

H00934-10

## 15.2 Installing the front wheel ↩



### Warning

**Danger of accidents** Oil or grease on the brake discs reduces the braking effect.

- Always keep the brake discs free of oil and grease.
- Clean the brake discs with brake cleaner when necessary.

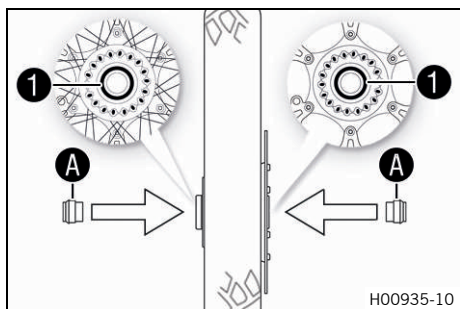

## Main work

- Check the wheel bearing for damage and wear.
  - » If the wheel bearing is damaged or worn:
    - Change front wheel bearing. 🛠️
- Clean and grease shaft seal rings ① and contact surfaces ①A of the spacers.

Long-life grease (📖 p. 145)

- Insert the spacers.

- Clean and grease the wheel spindle.

Long-life grease (📖 p. 145)

- Position the front wheel and insert the wheel spindle.

✓ The brake linings are correctly positioned.

- Mount and tighten screw ②.

Guideline

Screw, front wheel spindle	M20x1.5	35 Nm (25.8 lbf ft)
----------------------------	---------	---------------------

- Operate the front brake lever several times until the brake linings are in contact with the brake disc.

- Remove the motorcycle from the lift stand. (📖 p. 57)

- Operate the front brake and compress the fork a few times firmly.

✓ The fork legs straighten.

- Tighten screws ③.

Guideline

Screw, fork stub	M8	15 Nm (11.1 lbf ft)
------------------	----	---------------------

## Finishing work

- Install the Powerpack HV. (📖 p. 109)
- Lock the seat. (📖 p. 69)

## 15.3 Removing the rear wheel 🛠️

### Preparatory work

- Deactivate the vehicle. (📖 p. 43)
- Fold the seat up. (📖 p. 69)
- Remove the Powerpack HV. (📖 p. 108)
- Mount the protection cap. (📖 p. 71)
- Raise the motorcycle with a lift stand. (📖 p. 57)



### Main work

- Remove nut ①.
- Take off chain adjuster ②.



#### Info

Pull out wheel spindle ③ far enough to allow the rear wheel to be pushed forward.

- Push the rear wheel forward as far as possible. Remove the chain from the rear sprocket.



#### Info

Cover the components to protect them against damage.



#### Warning

**Danger of accidents** Damaged brake discs reduce the braking effect.

- Always lay the wheel down in such a way that the brake disc is not damaged.

- Hold the rear wheel and remove the wheel spindle. Take the rear wheel out of the link fork.



#### Info

Do not operate the rear brake lever when the rear wheel is removed.

- Remove spacers ④.

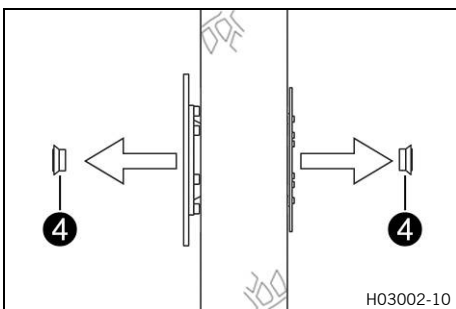

## 15.4 Installing the rear wheel ↩



#### Warning

**Danger of accidents** Oil or grease on the brake discs reduces the braking effect.

- Always keep the brake discs free of oil and grease.
- Clean the brake discs with brake cleaner when necessary.

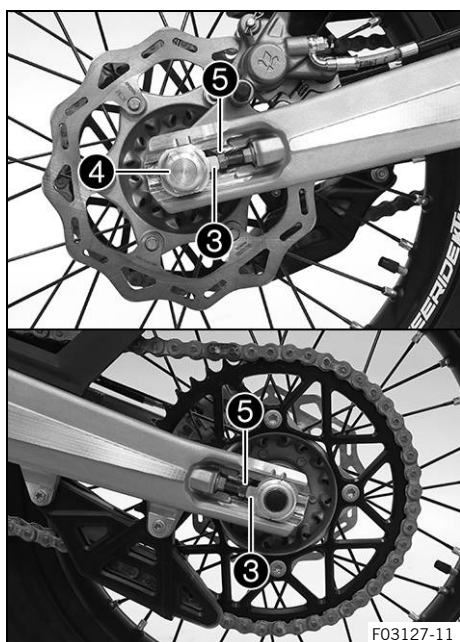
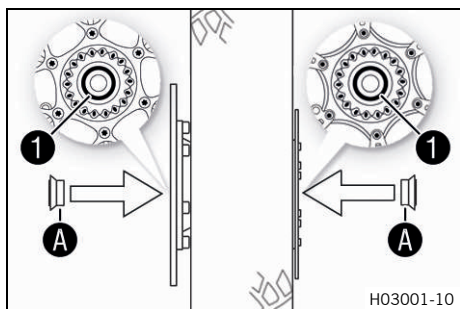

## Main work

- Check the wheel bearing for damage and wear.
  - » If the wheel bearing is damaged or worn:
    - Change the rear wheel bearing. 🛠️
- Clean and grease shaft seal rings ① and contact surfaces ①A of the spacers.

Long-life grease (📖 p. 145)

- Insert the spacers.
- Position the rear wheel.
  - ✓ The brake linings are correctly positioned.
- Insert wheel spindle ②.
- Mount the chain.
- Position chain adjuster ③. Mount nut ④, but do not tighten it yet.
- Make sure that chain adjusters ③ are fitted correctly on adjusting screws ⑤.
- Check the chain tension. (📖 p. 73)
- Tighten nut ④.

### Guideline

Nut, rear wheel spindle	M20x1.5	80 Nm (59 lbf ft)
-------------------------	---------	-------------------

### Info

The wide adjustment range of the chain adjusters enables different secondary ratios with the same chain length.  
Chain adjusters ③ can be turned by 180°.

- Operate the rear brake lever several times until the brake linings are in contact with the brake disc and there is a pressure point.

## Finishing work

- Remove the motorcycle from the lift stand. (📖 p. 57)
- Install the Powerpack HV. (📖 p. 109)
- Lock the seat. (📖 p. 69)



## 15.5 Checking the tire condition

### **i** Info

Only mount tires approved and/or recommended by KTM.  
 Other tires could have a negative effect on handling characteristics.  
 The type, condition, and pressure of the tires all have a major impact on the handling characteristic of the motorcycle.  
 The tires mounted on the front and rear wheels must have a similar profile.  
 Worn tires have a negative effect on handling characteristics, especially on wet surfaces.

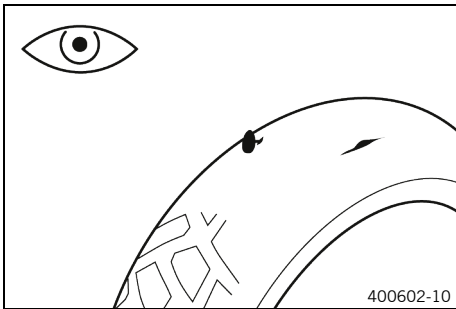

- Check the front and rear tires for cuts, run-in objects, and other damage.
  - » If the tires have cuts, run-in objects, or other damage:
    - Change the tires. 🛠️
- Check the tread depth.

### **i** Info

Observe the minimum profile depth required by national law.

Minimum tread depth	≥ 2 mm (≥ 0.08 in)
---------------------	--------------------

- » If the tread depth is less than the minimum tread depth:
  - Change the tires. 🛠️

- Check the tire age.

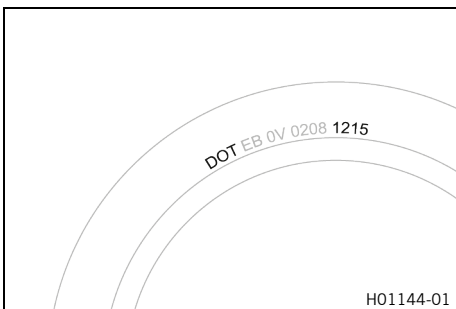

### **i** Info

The tire's date of manufacture is usually part of the tire markings and is indicated by four digits. The first two digits indicate the week of manufacture and the last two digits the year of manufacture.  
 KTM recommends that the tires be changed after 5 years at the latest, regardless of the actual state of wear.

- » If the tires are more than 5 years old:
  - Change the tires. 🛠️



## 15.6 Checking tire pressure

### **i** Info

Low tire pressure leads to abnormal wear and overheating of the tire.  
 Correct tire pressure ensures optimal riding comfort and maximum tire service life.

#### Preparatory work

- Deactivate the vehicle. (📖 p. 43)
- Fold the seat up. (📖 p. 69)
- Remove the Powerpack HV. (📖 p. 108)
- Mount the protection cap. (📖 p. 71)

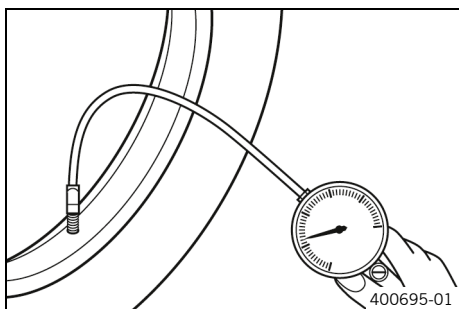

### Main work

- Remove the protection cap.
- Check the tire pressure when the tires are cold.

Offroad tire pressure	
front	0.9 bar (13 psi)
rear	0.7 bar (10 psi)

Street tire pressure	
front	2 bar (29 psi)
rear	2 bar (29 psi)

» If the tire pressure does not meet specifications:

- Correct the tire pressure.
- Mount the protection cap.

### Finishing work

- Install the Powerpack HV. (🔧 p. 109)
- Lock the seat. (🔧 p. 69)

## 15.7 Checking the spoke tension



### Warning

**Danger of accidents** Incorrectly tensioned spokes impair the handling characteristic and result in secondary damage.

The spokes break due to being overloaded if they are too tightly tensioned. If the tension in the spokes is too low, then lateral and radial run-out will form in the wheel. Other spokes will become looser as a result.

- Check spoke tension regularly, and in particular on a new vehicle. (Your authorized KTM workshop will be glad to help.)

### Preparatory work

- Deactivate the vehicle. (🔧 p. 43)
- Fold the seat up. (🔧 p. 69)
- Remove the Powerpack HV. (🔧 p. 108)
- Mount the protection cap. (🔧 p. 71)

### Main work

- Briefly strike each spoke with the tip of a screwdriver.

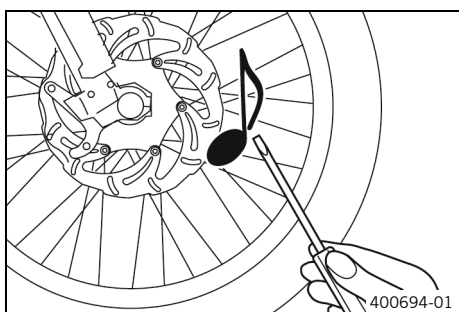

### Info

The tone frequency depends on the length of the spoke and the spoke diameter.

If spokes of equal length and diameter vibrate with a different tone, this is an indication that the spoke tensions differ.

You should hear a high note.

- » If the spoke tension varies:
  - Correct the spoke tension. 🛠️
- Check the spoke torque.

## Guideline

Spoke nipple	M4.5	6 Nm (4.4 lbf ft)
--------------	------	-------------------

Torque wrench kit (58429094000)
---------------------------------

**Finishing work**

- Install the Powerpack HV. (📖 p. 109)
- Lock the seat. (📖 p. 69)



## 16.1 Removing the 12-V battery ↴



### Warning

**Risk of injury** Battery gases cause serious chemical burns.

- Keep the 12 V batteries out of the reach of children.
- Wear suitable protective clothing and safety glasses.
- Avoid contact with battery gases.
- Keep sparks or open flames away from the 12 V battery.
- Only charge 12 V batteries in well-ventilated rooms.
- In the event of contact with the skin, rinse the affected area with plenty of water.
- Flush eyes with water for at least 15 minutes and consult a physician if battery gases have come into contact with the eyes.



### Note

**Environmental hazard** 12 V batteries contain environmentally hazardous materials.

- Do not dispose of 12 V batteries as household waste.
- Dispose of 12 V batteries at a collection point for used batteries.

### Preparatory work

- Deactivate the vehicle. (📖 p. 43)
- Fold the seat up. (📖 p. 69)

### Main work

- Disconnect negative cable **1** from the 12-V battery.
- Pull back positive terminal cover **2**.
- Disconnect positive cable **3** from the 12-V battery.
- Detach rubber strap **4**.
- Pull the 12-V battery upwards and out of the battery compartment.

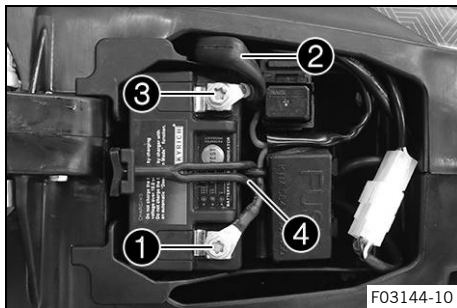

## 16.2 Installing the 12-V battery ↴



### Warning

**Risk of injury** Battery gases cause serious chemical burns.

- Keep the 12 V batteries out of the reach of children.
- Wear suitable protective clothing and safety glasses.
- Avoid contact with battery gases.
- Keep sparks or open flames away from the 12 V battery.
- Only charge 12 V batteries in well-ventilated rooms.
- In the event of contact with the skin, rinse the affected area with plenty of water.
- Flush eyes with water for at least 15 minutes and consult a physician if battery gases have come into contact with the eyes.

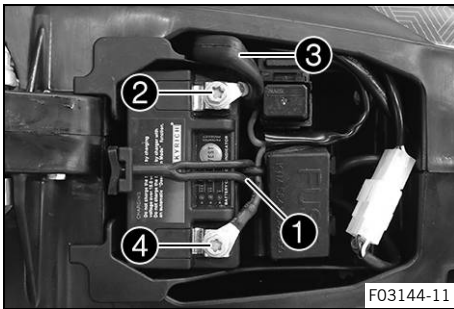
**Main work**

- Position the 12-V battery in the battery compartment.

12-V battery (LFP01) (📖 p. 139)

- Attach rubber strap ❶.
- Position positive cable ❷ and mount and tighten the screw.
- Position positive terminal cover ❸.
- Position negative cable ❹ and mount and tighten the screw.

**Finishing work**

- Lock the seat. (📖 p. 69)



## 16.3 Charging the 12-V battery ↘

**Warning**

**Risk of injury** 12 V batteries contain harmful substances.

- Keep 12 V batteries out of the reach of children.
- Keep sparks and open flames away from 12 V batteries.
- Only charge 12 V batteries in well-ventilated rooms.
- Maintain a minimum clearance from inflammable materials when charging 12 V batteries.  
Minimum clearance 1 m (3 ft)
- Do not charge deeply discharged 12 V batteries if the charge is already below the minimum voltage.  
Minimum voltage before the start of the charge 9 V
- Dispose of 12 V batteries with less than the minimum voltage correctly.

**Note**

**Environmental hazard** 12 V batteries contain environmentally hazardous materials.

- Do not dispose of 12 V batteries as household waste.
- Dispose of 12 V batteries at a collection point for used batteries.

**Info**

Even when there is no load on the 12-V battery, it discharges steadily each day. The charging level and the method of charging are very important for the service life of the 12-V battery. Rapid recharging with a high charging current shortens the service life of the battery. If the charging current, charging voltage, or charging time is exceeded, the 12 V battery will be destroyed. When the 12-V battery has been discharged (blink code 44 on the vehicle), recharge the 12-V battery immediately. If the 12-V battery is left in a discharged state for an extended period, it will become deeply discharged and suffer a loss of capacity, destroying the battery. The 12-V battery is maintenance-free.

**Info**

The 12-V battery is recharged by the Powerpack HV when operating the vehicle. When the Powerpack HV is recharged in the vehicle, then the 12-V battery is also recharged.

**Preparatory work**

- Deactivate the vehicle. (📖 p. 43)
- Fold the seat up. (📖 p. 69)
- Remove the 12-V battery. ↘ (📖 p. 98)



### Main work

- Check the battery voltage.
  - » Battery voltage: < 9 V
    - Do not charge the 12-V battery.
    - Replace the 12-V battery and dispose of the old 12-V battery properly.
  - » If the specifications have been met:
    - Connect a battery charger to the 12-V battery. Switch on the battery charger.

### Guideline

The charging current, charging voltage, and charging time must not be exceeded.	
Maximum charging voltage	14.4 V
Maximum charging current	3.0 A
Maximum charging time	24 h
Recharge the 12-V battery regularly when the motorcycle is not being used	6 months

Battery charger (58429074000)

These battery chargers test whether the 12-V battery retains its voltage. It is also impossible to overcharge the 12-V battery with these battery chargers. The charging time may be longer at low temperatures.

These battery chargers are only suitable for lithium iron phosphate batteries. Read the accompanying **KTM PowerParts** instructions.

**i Info**  
Never remove cover ①.

### Finishing work

- Install the 12-V battery. 📖 (p. 98)
- Lock the seat. 📖 (p. 69)

## 16.4 Changing the fuses of individual electrical power consumers

**i Info**  
The fuse box containing the fuses for the individual power consumers is located under the seat, behind the 12-V battery.

### Preparatory work

- Deactivate the vehicle. 📖 (p. 43)
- Fold the seat up. 📖 (p. 69)
- Remove the Powerpack HV. 📖 (p. 108)
- Mount the protection cap. 📖 (p. 71)

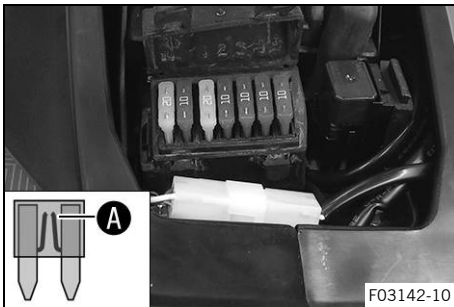
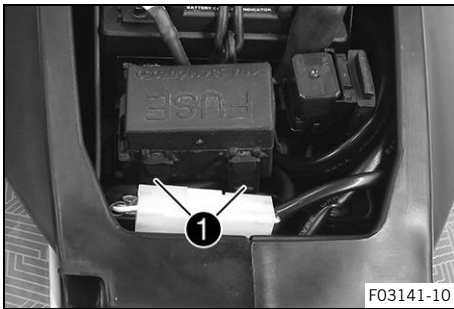

### Main work

- Detach catches ① and open the fuse box cover.

- Remove the faulty fuse.

#### Guideline

Fuses <b>res</b> - 10 A and 20 A - spare fuses
Fuse <b>1</b> - 20 A - main fuse, engine control unit, ignition lock
Fuse <b>2</b> - 10 A - ignition lock, main switch, start button
Fuse <b>3</b> - 10 A - high beam, low beam
Fuse <b>4</b> - 10 A - horn, brake light, turn signal
Fuse <b>5</b> - 10 A - water pump



#### Info

A faulty fuse has a burned-out fuse wire ①.



#### Warning

**Fire hazard** Incorrect fuses overload the electrical system.

- Only use fuses with the required ampere value.
- Do not bypass or repair fuses.

- Insert the spare fuse with the correct rating.

Fuse (75011088010) (📖 p. 139)

Fuse (75011088020) (📖 p. 139)



#### Tip

Put a spare fuse in the fuse box so that it is available if needed.

- Check the function of the electrical power consumer.
- Close the fuse box cover and allow the catches to engage.

### Finishing work

- Install the Powerpack HV. (📖 p. 109)
- Lock the seat. (📖 p. 69)

## 16.5 Removing the headlight mask with the headlight

### Preparatory work

- Deactivate the vehicle. (🔌 p. 43)
- Fold the seat up. (🔌 p. 69)
- Remove the Powerpack HV. (🔌 p. 108)
- Mount the protection cap. (🔌 p. 71)

### Main work

- Detach the brake line and wiring harness **1**.
- Loosen rubber straps **2**. Slide the headlight mask up and swing it forward.

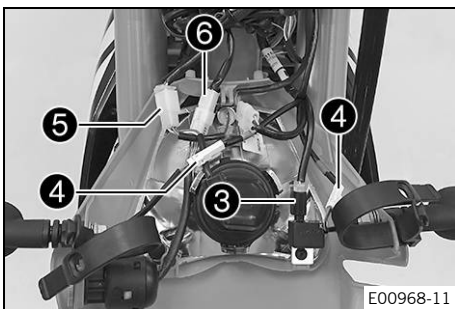
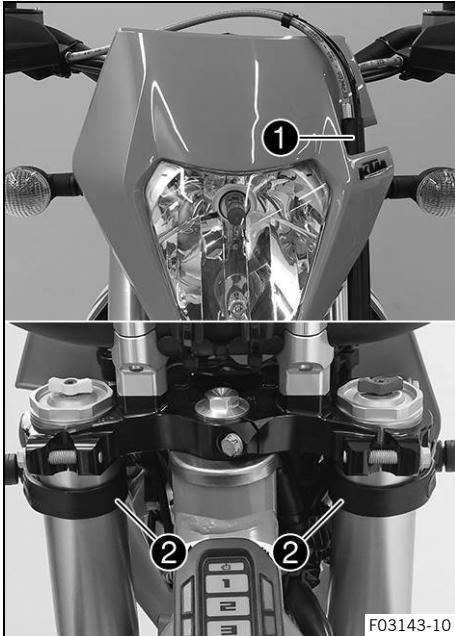

- Disconnect plug-in connector **3** of the turn signal relay, plug-in connectors **4** of the turn signals, plug-in connector **5** of the headlight and plug-in connector **6** of the ignition lock.

## 16.6 Installing the headlight mask with the headlight

### Main work

- Join plug-in connector **1** of the turn signal relay, plug-in connectors **2** of the turn signals, plug-in connector **3** of the headlight and plug-in connector **4** of the ignition lock.

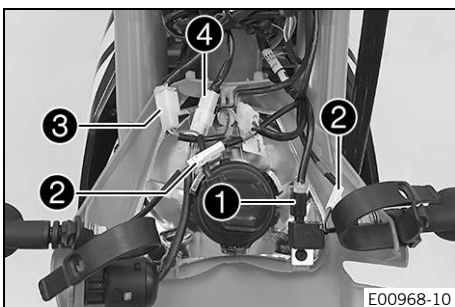



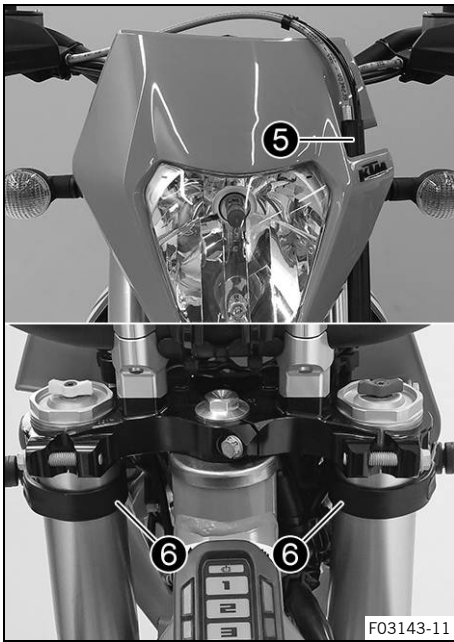

- Attach the brake line and wiring harness ⑤.
- Position the headlight mask and secure it with rubber straps ⑥.
- ✓ The holding lugs on the headlight mask engage in the fender.

#### Finishing work

- Install the Powerpack HV. (📖 p. 109)
- Lock the seat. (📖 p. 69)
- Check the headlight setting. (📖 p. 105)



## 16.7 Changing the headlight bulb

### Note

**Damage to reflector** Grease on the reflector reduces the light intensity.

Grease on the bulb will evaporate due to the heat and be deposited on the reflector.

- Clean and degrease the bulbs before mounting.
- Do not touch the bulbs with your bare hands.

### Preparatory work

- Deactivate the vehicle. (📖 p. 43)
- Fold the seat up. (📖 p. 69)
- Remove the Powerpack HV. (📖 p. 108)
- Mount the protection cap. (📖 p. 71)
- Remove the headlight mask with the headlight. (📖 p. 102)

### Main work

- Turn rubber cap ① with the bulb socket beneath it all the way counterclockwise and lift it off.
- Pull bulb socket ② of the position light out of the reflector.

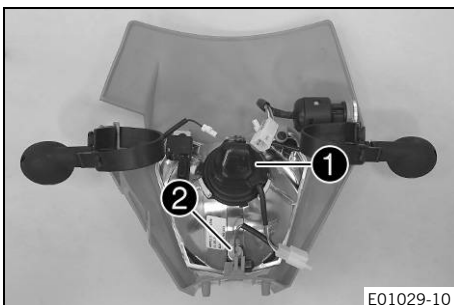

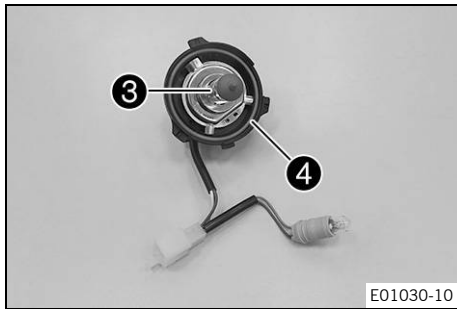

- Push headlight bulb ③ lightly into the bulb socket, turn it all the way counterclockwise, and remove it.
- Insert the new headlight bulb.

Headlight (HS1 / socket PX43t) (📖 p. 139)

- Insert the rubber cap with the bulb socket into the reflector and turn it all the way clockwise.



### Info

Ensure that O-ring ④ is seated properly.

- Insert the bulb socket of the position light into the reflector.

### Finishing work

- Install the headlight mask with the headlight. (📖 p. 102)
- Install the Powerpack HV. (📖 p. 109)
- Lock the seat. (📖 p. 69)
- Check the headlight setting. (📖 p. 105)

## 16.8 Changing the turn signal bulb

### Note

**Damage to reflector** Grease on the reflector reduces the light intensity.

Grease on the bulb will evaporate due to the heat and be deposited on the reflector.

- Clean and degrease the bulbs before mounting.
- Do not touch the bulbs with your bare hands.

### Preparatory work

- Deactivate the vehicle. (📖 p. 43)
- Fold the seat up. (📖 p. 69)
- Remove the Powerpack HV. (📖 p. 108)
- Mount the protection cap. (📖 p. 71)

### Main work

- Remove the screw on the rear of the turn signal housing.
- Carefully remove turn signal glass ①.
- Lightly squeeze together the orange cap ② in the area of the holding lugs and take it off.
- Press the turn signal bulb lightly into the socket, turn it counterclockwise by about 30°, and take it out of the socket.



### Info

Do not touch the reflector with your fingers and keep it free from grease.

- Press the new turn signal bulb carefully into the socket and turn it clockwise until it stops.

Turn signal (R10W/socket BA15s) (📖 p. 139)

- Mount the orange cap.
- Position the turn signal glass.

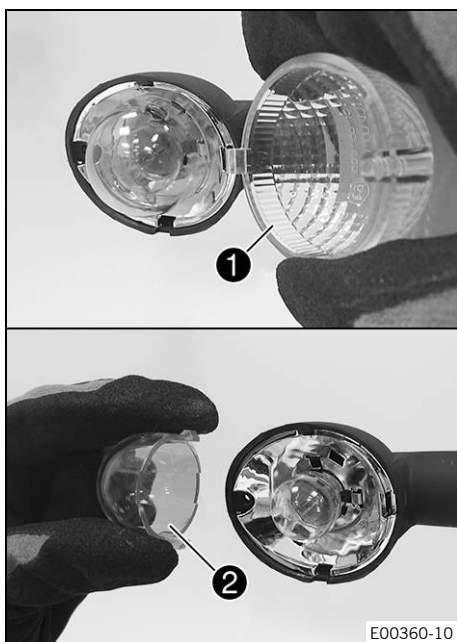

- Insert the screw and first turn counterclockwise until it engages in the thread with a small jerk. Tighten the screw lightly.

#### Finishing work

- Install the Powerpack HV. (📖 p. 109)
- Lock the seat. (📖 p. 69)
- Check that the turn signal system is functioning properly.



### 16.9 Checking the headlight setting

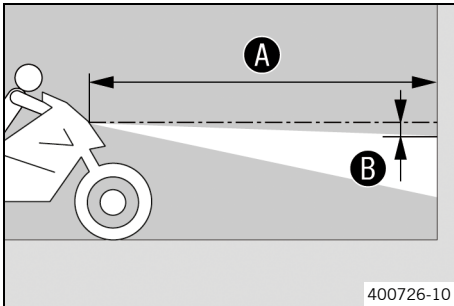

- Position the vehicle upright on a horizontal surface in front of a light wall and make a mark at the height of the center of the low beam headlight.
- Make another mark at a distance **B** under the first marking.

#### Guideline

Distance <b>B</b>	5 cm (2 in)
-------------------	-------------

- Position the vehicle vertically a distance **A** away from the wall.

#### Guideline

Distance <b>A</b>	5 m (16 ft)
-------------------	-------------

- The rider now sits down on the motorcycle with a full set of protective clothing.
- Turn the ignition key in the ignition lock to the position  $\odot$ .
- Push the main switch into position  $\odot$ .
- Switch on the low beam.
- Check the headlight setting.

The boundary between light and dark must be exactly on the lower marking for a motorcycle with rider.

- » If the boundary between light and dark does not meet specifications:
  - Adjust the headlight range. (📖 p. 105)



### 16.10 Adjusting the headlight range

#### Preparatory work

- Check the headlight setting. (📖 p. 105)

#### Main work

- Loosen screw **1**.
- Adjust the headlight range by pivoting the headlight.

#### Guideline

The boundary between light and dark must be exactly on the lower mark for a motorcycle with rider (instructions on how to apply the mark: Checking the headlight setting).



#### Info

A change in weight on the vehicle may require a correction of the headlight range.

- Tighten screw ❶.

## 16.11 Changing the combination instrument battery

### Preparatory work

- Deactivate the vehicle. (📖 p. 43)
- Fold the seat up. (📖 p. 69)
- Remove the Powerpack HV. (📖 p. 108)
- Mount the protection cap. (📖 p. 71)
- Remove the headlight mask with the headlight. (📖 p. 102)

### Main work

- Remove screws ❶.
- Pull the combination instrument upward out of the holder.

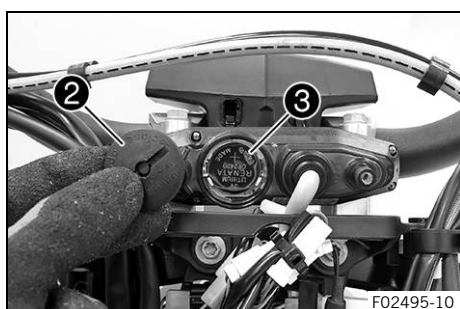
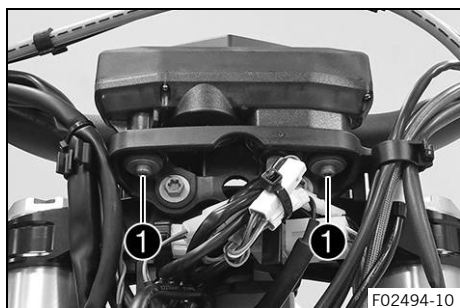

- Using a coin, turn protection cap ❷ all the way counterclockwise and take it off.
- Remove combination instrument battery ❸.
- Insert the combination instrument battery with the label facing outward.

Combination instrument battery (CR 2430) (📖 p. 139)

- Check the O-ring of the protection cap for correct seating.

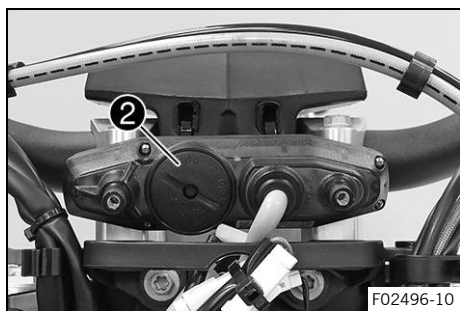

- Position protection cap ❷ and turn all the way clockwise using a coin.
- Press any button on the combination instrument.
- ✓ The combination instrument is activated.
- Position the combination instrument in the holder.
- Mount and tighten the screws with washers.

### Guideline

Screw, combination instrument on combination instrument bracket	<b>EJOT DELTA PT</b> ® 45x12-Z	1 Nm (0.7 lbf ft)
---	-----------------------------------	-------------------

### Finishing work

- Install the headlight mask with the headlight. (📖 p. 102)
- Install the Powerpack HV. (📖 p. 109)
- Lock the seat. (📖 p. 69)
- Check the headlight setting. (📖 p. 105)
- Set the kilometers or miles. (📖 p. 27)
- Set the combination instrument. (📖 p. 28)
- Set the clock. (📖 p. 29)

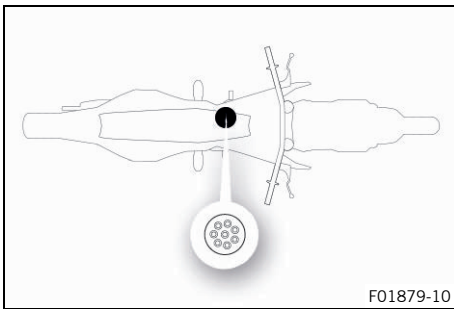
**16.12 Diagnostic connection**

Diagnostic connection ① is located under the front rider's seat.

**Info**

The charging socket is also the diagnostic connection.

## 17.1 Removing the Powerpack HV



### Warning

**Risk of injury** There is a risk of electric shock when working on high-voltage components. Work on high-voltage components requires special training, qualifications and tools.

- Work which has not been described and explained may only be performed by appropriately trained KTM specialists. (Your authorized KTM workshop will be glad to help.)
- Do not open the electric motor or the Powerpack HV. (Your authorized KTM workshop will be glad to help.)



### Note

**Environmental hazard** A lithium-ion battery (Powerpack) contains components and elements that are harmful to the environment.

- Never throw a Powerpack into the household trash.
- Dispose of the Powerpack properly and in compliance with the applicable regulations. (Your authorized KTM workshop will be glad to help.)

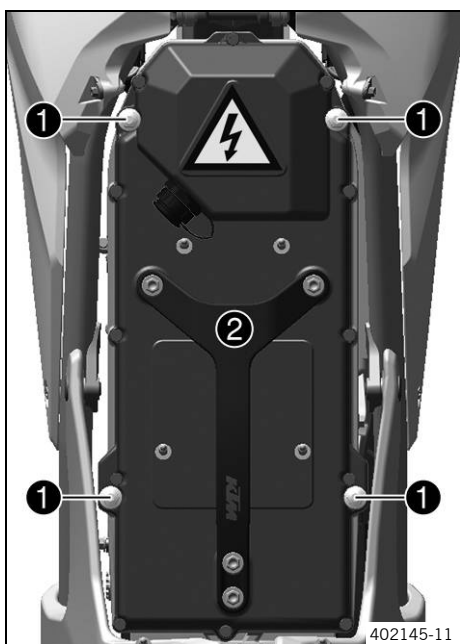

### Preparatory work

- Deactivate the vehicle. (📖 p. 43)
- Fold the seat up. (📖 p. 69)

### Main work

- Loosen screws ❶.

### Note

**Material damage** Components damaged or destroyed by water or dirt.

- Mount the protection cap after you have removed the Powerpack HV.
- Place the Powerpack HV on a clean and dry surface.

- Remove Powerpack HV ❷.

Lifting strap (70029022000)



### Info

The Powerpack HV is very heavy. A second person can help with removal.

### Finishing work

- Mount the protection cap. (📖 p. 71)

## 17.2 Installing the Powerpack HV



### Caution

**Risk of injury** The Powerpack HV is very heavy.

The Powerpack HV must rest flush on the electric motor after installation.

- Only lift the Powerpack HV by the carrying handle.
- Make sure that nobody is pinched when the Powerpack HV is removed or installed.

### Note

**Material damage** Components damaged or destroyed by water or dirt.

- Before installing the Powerpack HV, check the discharge plug on the electric motor and the discharge socket on the Powerpack HV for cleanliness.
- Check the battery discharge plug form ring.
- Clean the battery discharge plug and the battery discharge socket without using water or compressed air if the battery discharge plug or the battery discharge socket is dirty.
- After cleaning, spray silicone spray onto the battery discharge plug form ring.

### Main work

- Remove the protection cap. (📖 p. 71)
- Check the battery discharge plug form ring. (📖 p. 71)
- Position Powerpack HV ① in the vehicle.

Lifting strap (70029022000)
-----------------------------

- ✓ The Powerpack HV rests flush with the electric motor.



### Info

The Powerpack HV is very heavy. A second person can help with installation.

- Tighten screws ②.

### Guideline

Attaching Powerpack HV	M6	10 Nm (7.4 lbf ft)
------------------------	----	--------------------

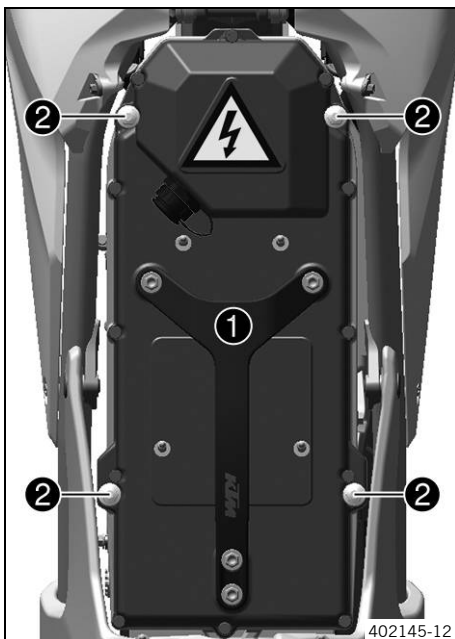

### Finishing work

- Lock the seat. (📖 p. 69)

## 17.3 Overview of the battery charger for the Powerpack HV (Option: Battery charger 1)



402153-10

- ① Residual current protection switch
- ② "On" charger switch
- ③ "Off" charger switch
- ④ Battery charger
- ⑤ Charging mode switch
- ⑥ Charging level indicator
- ⑦ Status indicator
- ⑧ LED for malfunctions on the Powerpack HV
- ⑨ LED for malfunctions on the battery charger



17.4 Overview of the battery charger for the Powerpack HV (Option: Battery charger 2)

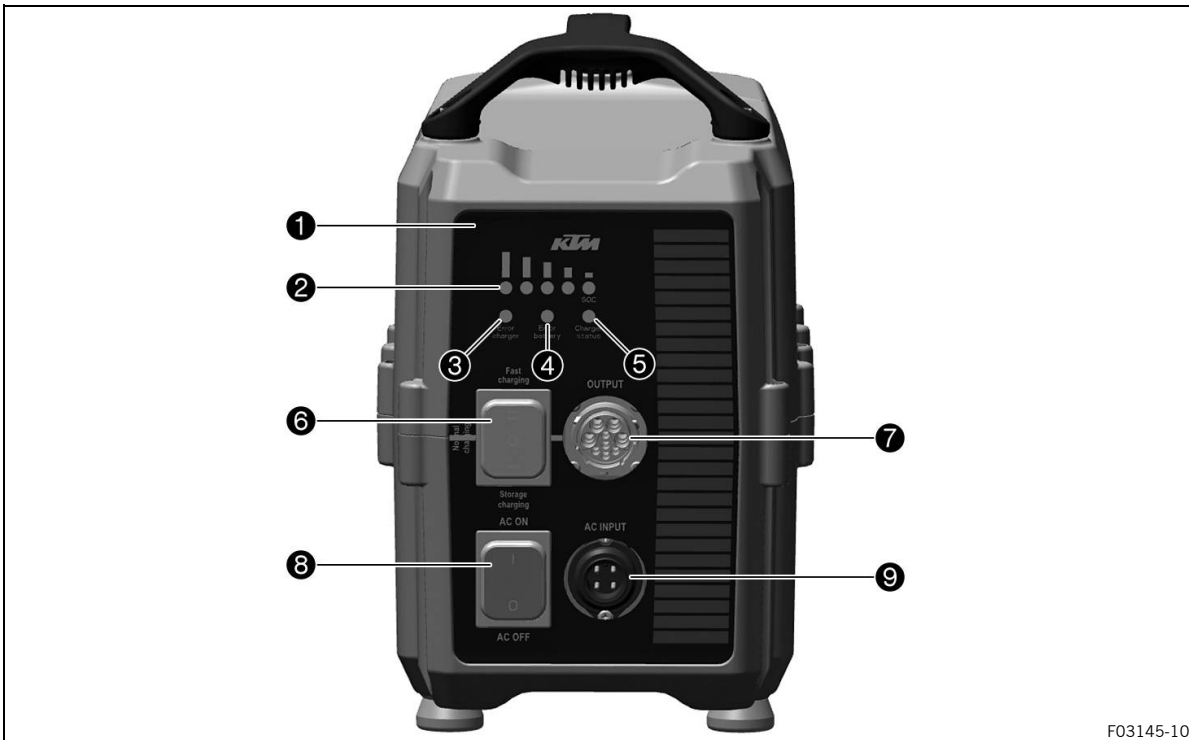

F03145-10

- ① Battery charger
- ② Charging level indicator
- ③ LED for malfunctions on the battery charger
- ④ LED for malfunctions on the Powerpack HV
- ⑤ Status indicator
- ⑥ Charging mode switch
- ⑦ Charging socket
- ⑧ On and off switch
- ⑨ Power supply bushing

17.5 Positioning the battery charger

**Warning**  
**Risk of injury** There is a risk of electric shock in a moist environment.  
 The battery charger is not waterproof.

- Only use the battery charger in dry conditions.
- Ensure that no fluids flow or drip onto the battery charger.

**Warning**  
**Risk of injury** If the battery charger is used incorrectly, its intrinsic safety cannot be guaranteed.  
 The battery charger is only suitable for use with a Powerpack.

- Only use the battery charger with a Powerpack.
- Only operate the battery charger using household sockets with a ground conductor.
- Do not use any additional adapters or extensions.
- Follow the applicable safety instructions of the power connection.



## Warning

**Risk of injury** There is a risk of electric shock if the battery charger or the cables have been manipulated or damaged.

The battery charger does not contain any parts which require maintenance.

- Do not modify the battery charger or the cables.
- Only use original cables.
- Never open the battery charger housing.
- Do not insert any objects into the battery charger housing from the outside.
- Do not use the battery charger if cables, plugs, or parts of the battery charger have been damaged or are soiled.



## Info

The battery charger contains sensitive electronics and must be handled with appropriate care. The battery charger may be damaged or destroyed if it is dropped, knocked or otherwise subject to mechanical overload.

When transporting the battery charger, ensure appropriate means of securing the cargo.

Damage caused due to improper handling or improper transport is excluded from the manufacturer warranty.



### (Option: Battery charger 1)

- Place the battery charger on a firm, level, and horizontal surface.
- Ensure the battery charger is adequately ventilated.

Guideline

Free space at the front and rear side of the battery charger	≥ 20 cm (≥ 7.9 in)
--	--------------------

- Use the battery charger in the temperature range permitted.

Guideline

Ambient temperature	-15 ... 50 °C (5 ... 122 °F)
---------------------	------------------------------

- Ensure that the power plug for the battery charger always remains easily accessible.

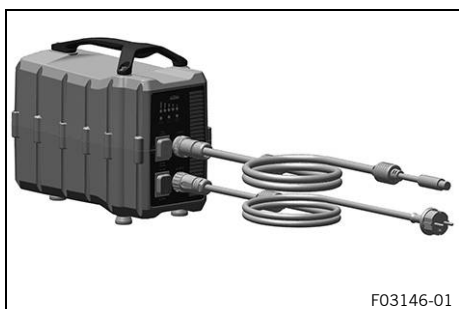

### (Option: Battery charger 2)

- Place the battery charger on a firm, level, and horizontal surface.
- Ensure that both the power cord and the charging cable are connected and secured.
  - » If the power cord or the charging cable are not connected and secured:
    - Connect the power cord to the battery charger and screw the lock ring tight clockwise.
    - Connect the charging cable to the battery charger and screw the lock ring tight clockwise.
- Ensure the battery charger is adequately ventilated.

## Guideline

Free space at the front and rear side of the battery charger	≥ 20 cm (≥ 7.9 in)
--	--------------------

- Use the battery charger in the temperature range permitted.

## Guideline

Ambient temperature	-15 ... 50 °C (5 ... 122 °F)
---------------------	------------------------------

- Ensure that the power plug for the battery charger always remains easily accessible.



## 17.6 Checking residual current protection switch (Option: Battery charger 1)

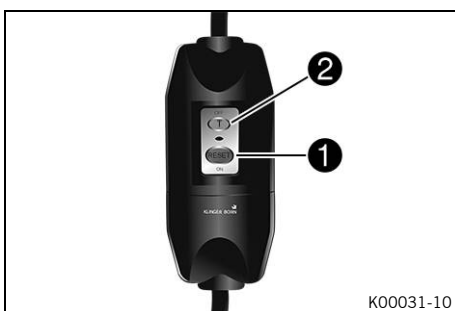

### Warning

**Risk of injury** There is a risk of electric shock with a faulty residual current protection switch.

- Before each use of the charger check the residual current protection switch.
- Do not use the battery charger if the test procedure was not successful.

- Connect the mains plug to the mains connection.
- Press the ① button.
  - ✓ The operating display lights up red.
- Press the ② button.
  - ✓ The operating display goes out.
  - ✓ The residual current protection switch can be used.
- Disconnect power plug from mains connection.



## 17.7 Charging the Powerpack HV

### Note

**Material damage** The power supply will be damaged in the event of an overload.

In charge mode **Fast**, a steady current of at least 13 A is required.

In charge mode **Normal**, a steady current of at least 10 A is required.

- Ensure that the power outlet can supply the steady current required and is protected by a suitable fuse.



### Note

**Environmental hazard** A lithium-ion battery (Powerpack) contains components and elements that are harmful to the environment.

- Never throw a Powerpack into the household trash.
- Dispose of the Powerpack properly and in compliance with the applicable regulations. (Your authorized KTM workshop will be glad to help.)

**i Info**

The charging procedure is identical regardless of whether the Powerpack HV is charged while installed in the vehicle or having been removed. However, the 12-V battery is only charged if the Powerpack HV is being charged in the vehicle.

Charge the Powerpack HV regularly inside the vehicle in order to charge the 12-V battery as well.

Do not activate the vehicle while the battery charger is connected to the Powerpack HV.

If the vehicle is activated while being charged with the installed Powerpack HV, the vehicle switches to the malfunction state. The Powerpack HV will continue to be recharged; however, the 12-V battery will stop recharging.

**i Info**

When the left LED in the charging level indicator on the battery charger flashes, the PowerPack HV is ready for use. However, full capacity is not yet available.

To guarantee the maximum capacity of the Powerpack HV, discharge the Powerpack HV completely every 20 charging cycles and then recharge it completely. If this process is not carried out, then the vehicle may switch off due to a charging level which is too low without reducing power beforehand.

The Powerpack HV is completely discharged when the vehicle switches off with blink code 11.

**i Info**

If the temperature of the Powerpack HV exceeds the permissible value while it is being charged, the battery charger stops charging. All LEDs and the LEDs for the current charging level alternately light up every second.

After the temperature of the Powerpack HV returns to the permissible range, charging is resumed automatically.

**Preparatory work**

- Position the battery charger. (📖 p. 111)

**(Option: Battery charger 1)**

- Check residual current protection switch. (📖 p. 113)
- Push the main switch into position ☒.
- Fold the seat up. (📖 p. 69)

**Main work**

- Remove charging socket protection cap ❶.

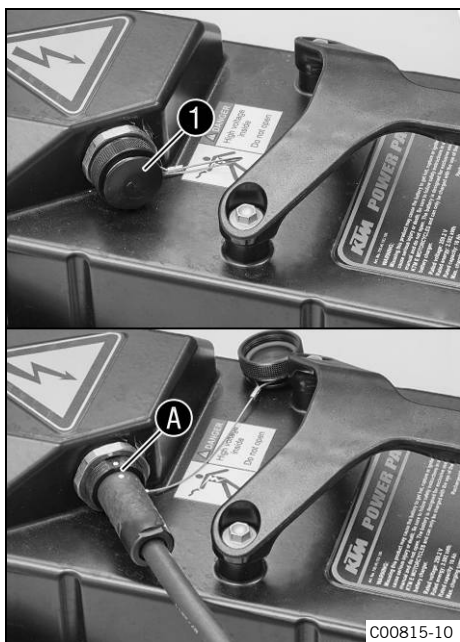

**Warning**

**Risk of injury** The intrinsic safety of the Powerpack HV can only be guaranteed if the original battery charger is used.

The Powerpack HV may only be charged with the original battery charger.

- Only use the original battery charger to charge the Powerpack HV.

- Connect the battery charger to the Powerpack HV. Observe plug marking ❷.



### (Option: Battery charger 1)

- Connect the power plug for the battery charger to the mains connection.
- Set the charging mode switch **2** to the **Fast** position or **Normal** position.

### **i** Info

In charging mode **Fast**, the Powerpack HV is completely charged after approx. 105 minutes. The power consumption is higher than in charging mode **Normal**.

In charging mode **Normal**, the Powerpack HV is completely charged after approx. 135 minutes.



- Switch on the battery charger using switch **3**.
- ✓ Charging starts automatically. The status indicator flashes during the charging process.



- Monitor the charging level of the Powerpack HV via the LEDs.
  - LED 1: 20 %
  - LED 2: 40 %
  - LED 3: 60 %
  - LED 4: 80 %
  - LED 5 flashes beginning with approx. 95% until 100% is reached.
- Once the charging process is complete, all five LEDs light up and the status indicator goes out.



- Switch off the battery charger using switch **4**.
- ✓ After several seconds, all LEDs on the battery charger go out.
- Disconnect the battery charger power plug from the mains connection.
- Disconnect the charging cable from the Powerpack HV.

### Guideline

Pull on the structured part of the plug. Do not pull on the cable.

- Check the seal on the charging socket protection cap.
  - » If the seal is dirty:
    - Clean the seal without using water or compressed air.
  - » If the seal is damaged or worn:
    - Change the seal.
- Mount the charging socket protection cap.

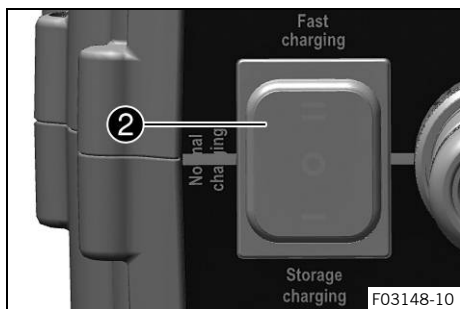

### (Option: Battery charger 2)

- Connect the power plug for the battery charger to the mains connection.
- Set the charging mode switch **2** to the **Fast** position or **Normal** position.

**i Info**  
 In charging mode **Fast**, the Powerpack HV is completely charged after approx. 105 minutes. The power consumption is higher than in charging mode **Normal**.  
 In charging mode **Normal**, the Powerpack HV is completely charged after approx. 135 minutes.

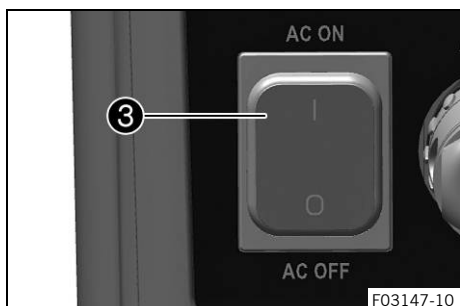

- Switch on the battery charger using switch **3**.  
 ✓ Charging starts automatically. The status indicator flashes during the charging process.

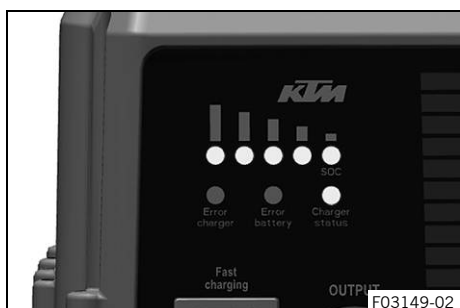

- Monitor the charging level of the Powerpack HV via the LEDs.  
 LED 1: 20 %  
 LED 2: 40 %  
 LED 3: 60 %  
 LED 4: 80 %  
 LED 5 flashes beginning with approx. 95% until 100% is reached.  
 Once the charging process is complete, all five LEDs light up and the status indicator goes out.

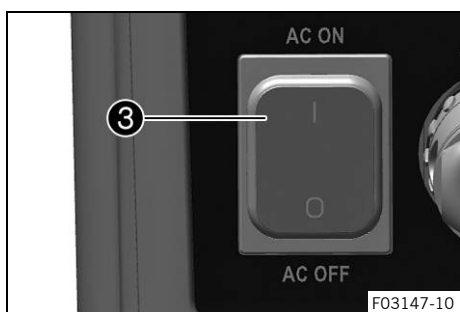

- Switch off the battery charger using switch **3**.  
 ✓ After several seconds, all LEDs on the battery charger go out.
- Disconnect the battery charger power plug from the mains connection.
- Disconnect the charging cable from the Powerpack HV.

#### Guideline

Pull on the structured part of the plug. Do not pull on the cable.

- Check the seal on the charging socket protection cap.
  - » If the seal is dirty:
    - Clean the seal without using water or compressed air.
  - » If the seal is damaged or worn:
    - Change the seal.
- Mount the charging socket protection cap.

## Finishing work

- Lock the seat. (📖 p. 69)



## 17.8 Charging the Powerpack HV in charging mode Storage

### Note

**Material damage** The power supply will be damaged in the event of an overload.

In the **Storage** charging mode, a steady current of at least 10 A is required.

- Ensure that the mains connection can supply the steady current required and is protected by a suitable fuse.



### Note

**Environmental hazard** A lithium-ion battery (Powerpack) contains components and elements that are harmful to the environment.

- Never throw a Powerpack into the household trash.
- Dispose of the Powerpack properly and in compliance with the applicable regulations. (Your authorized KTM workshop will be glad to help.)



### Info

The charging level of the Powerpack HV must be below 30 % before the **Storage** charging mode can be used.

If the temperature of the Powerpack HV exceeds the permissible value while it is being charged, the battery charger stops charging. All LEDs and the LEDs for the current charging level alternately light up every second.

After the temperature of the Powerpack HV returns to the permissible range, charging is resumed automatically.

## Preparatory work

- Position the battery charger. (📖 p. 111)

## Main work

- Remove charging socket protection cap ❶.



### Warning

**Risk of injury** The intrinsic safety of the Powerpack HV can only be guaranteed if the original battery charger is used.

The Powerpack HV may only be charged with the original battery charger.

- Only use the original battery charger to charge the Powerpack HV.

- Connect the battery charger to the Powerpack HV. Observe plug marking ❷.



C00815-10

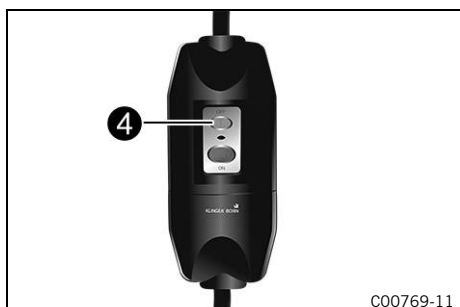

### (Option: Battery charger 1)

- Connect the power plug for the battery charger to the mains connection.
- Set the charging mode switch **2** to the **Storage** position.

- Switch on the battery charger using switch **3**.
  - ✓ Charging starts automatically. The status indicator flashes during the charging process.

- Monitor the charging level of the Powerpack HV via the LEDs.  
After the charging process is completed to a level of 30 %, LEDs 1 and 2 light up and the status indicator goes out.

- Switch off the battery charger using switch **4**.
  - ✓ After several seconds, all LEDs on the battery charger go out.
- Disconnect the battery charger power plug from the mains connection.
- Disconnect the charging cable from the Powerpack HV.

#### Guideline

Pull on the structured part of the plug. Do not pull on the cable.

- Check the seal on the charging socket protection cap.
  - » If the seal is dirty:
    - Clean the seal without using water or compressed air.
  - » If the seal is damaged or worn:
    - Change the seal.
- Mount the charging socket protection cap.



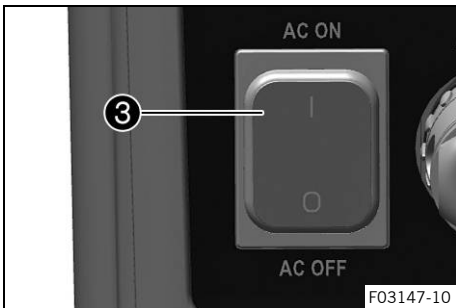
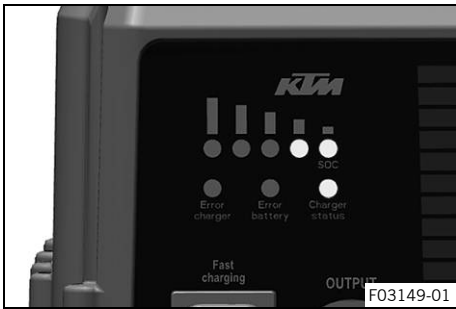
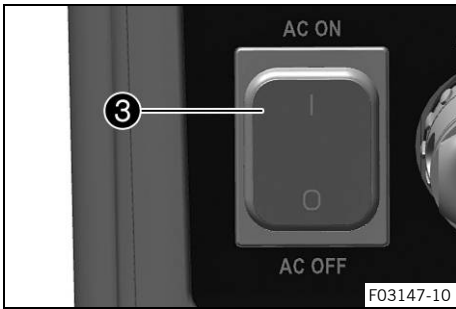
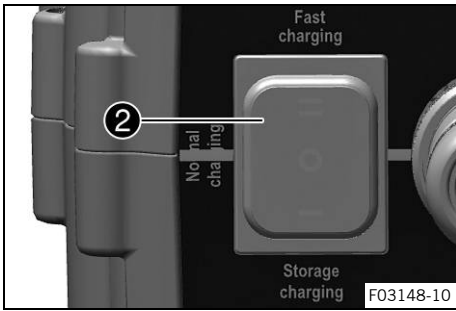

**(Option: Battery charger 2)**

- Connect the power plug for the battery charger to the mains connection.
  - Set the charging mode switch ② to the **Storage** position.
  
  - Switch on the battery charger using switch ③.
    - ✓ Charging starts automatically. The status indicator flashes during the charging process.
  
  - Monitor the charging level of the Powerpack HV via the LEDs.
 

After the charging process is completed to a level of 30 %, LEDs 1 and 2 light up and the status indicator goes out.
  
  - Switch off the battery charger using switch ③.
    - ✓ After several seconds, all LEDs on the battery charger go out.
  - Disconnect the battery charger power plug from the mains connection.
  - Disconnect the charging cable from the Powerpack HV.
- Guideline
- Pull on the structured part of the plug. Do not pull on the cable.
- Check the seal on the charging socket protection cap.
    - » If the seal is dirty:
      - Clean the seal without using water or compressed air.
    - » If the seal is damaged or worn:
      - Change the seal.
  - Mount the charging socket protection cap.

## 17.9 Changing charging socket protection cap



### Warning

**Risk of injury** There is a risk of electric shock when working on high-voltage components. Work on high-voltage components requires special training, qualifications and tools.

- Have all work that is not described and explained performed by trained KTM mechanics only.
- Do not open the electric motor or the lithium-ion battery (Powerpack HV).



### Info

If the safety cord or seal ring is damaged or torn off, the charging socket protection cap must be replaced.

### Preparatory work

- Deactivate the vehicle. (🔧 p. 43)
- Fold the seat up. (🔧 p. 69)
- Remove the Powerpack HV. (🔧 p. 108)
- Mount the protection cap. (🔧 p. 71)

### Main work

- Remove charging socket protection cap ❶.

#### Guideline

Do not loosen ❸ nut.

- Remove residual safety cord.
- Remove screws ❷.
- Take off the carry handle.

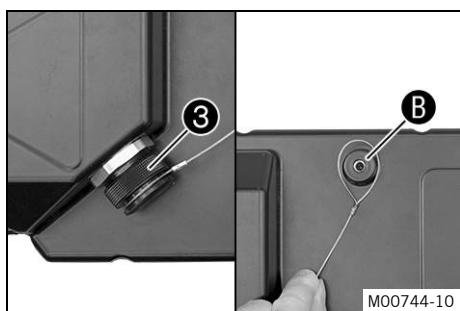
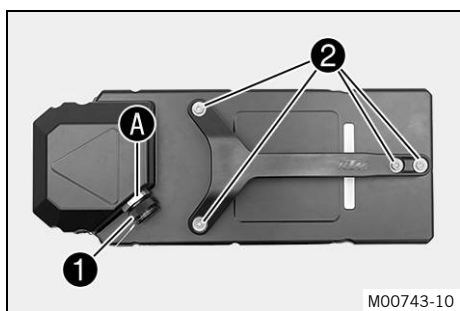

- Install new charging socket ❸ protection cap.

Charging socket protection cap (000700000FX01)

- Position loop around the right ❹ carry handle attachment.

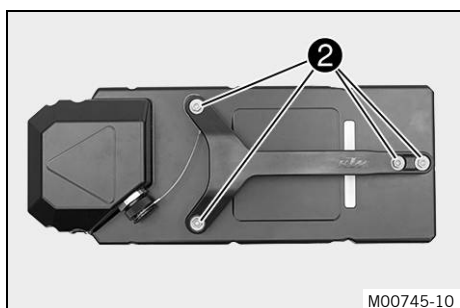

- Position carry handle.

#### Guideline

Do not pinch the loop between the Powerpack HV and the carrying handle.

- Mount and tighten screws ❷.

#### Guideline

Screw, carrying handle	M6	5 Nm (3.7 lbf ft)
------------------------	----	-------------------

### Finishing work

- Install the Powerpack HV. (🔧 p. 109)
- Lock the seat. (🔧 p. 69)

18.1 Cooling system

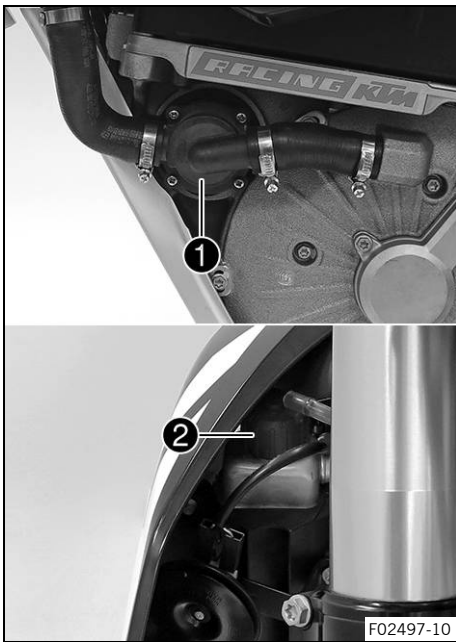

When the vehicle is in standby mode, the water pump ❶ pumps the coolant through the cooling circuit. The pressure in the cooling system increases with the temperature of the coolant. A safety valve is contained in radiator cap ❷. This ensures that operating the vehicle at the specified coolant temperature will not result in a risk of malfunctions.

65 °C (149 °F)

Cooling is effected by the air stream. The lower the speed, the less the cooling effect. Dirty cooling fins also reduce the cooling effect.

18.2 Checking the antifreeze and coolant level



**Warning**

**Danger of scalding** During motorcycle operation, the coolant gets very hot and is under pressure.

- Do not remove the radiator cap, radiator hoses or other cooling system components when the motor is hot. Allow the motor and cooling system to cool down. In case of scalding, rinse immediately with lukewarm water.



**Warning**

**Danger of poisoning** Coolant is toxic and a health hazard.

- Keep coolant out of the reach of children.
- Do not allow coolant to come into contact with the skin, the eyes and clothing.
- Consult a doctor immediately if coolant is swallowed.
- Rinse the affected area immediately with plenty of water in the event of contact with the skin.
- Rinse eyes thoroughly with water and consult a doctor immediately if coolant gets into the eyes.
- Change clothing if coolant spills onto your clothing.

**Condition**

The motor is cold.

**Preparatory work**

- Deactivate the vehicle. (📖 p. 43)
- Fold the seat up. (📖 p. 69)
- Remove the Powerpack HV. (📖 p. 108)
- Mount the protection cap. (📖 p. 71)
- Raise the motorcycle with a lift stand. (📖 p. 57)

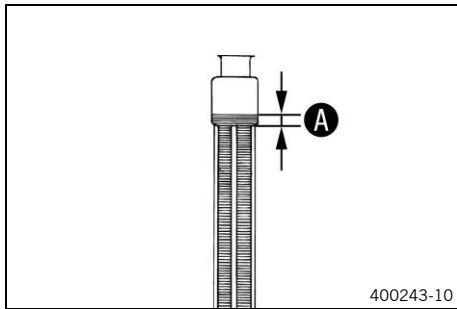

### Main work

- Remove the radiator cap.
- Check the antifreeze in the coolant.

-25 ... -45 °C (-13 ... -49 °F)
---------------------------------

- » If the antifreeze in the coolant does not match the specified value:

- Correct the antifreeze in the coolant.

- Check the coolant level in the radiator.

Coolant level <b>A</b> above the radiator fins	10 mm (0.39 in)
--	-----------------

- » If the coolant level does not meet specifications:

- Correct the coolant level.

Coolant (📖 p. 143)
--------------------

- Mount the radiator cap.

### Finishing work

- Remove the motorcycle from the lift stand. (📖 p. 57)
- Install the Powerpack HV. (📖 p. 109)
- Lock the seat. (📖 p. 69)

## 18.3 Checking the coolant level



### Warning

**Danger of scalding** During motorcycle operation, the coolant gets very hot and is under pressure.

- Do not remove the radiator cap, radiator hoses or other cooling system components when the motor is hot. Allow the motor and cooling system to cool down. In case of scalding, rinse immediately with lukewarm water.



### Warning

**Danger of poisoning** Coolant is toxic and a health hazard.

- Keep coolant out of the reach of children.
- Do not allow coolant to come into contact with the skin, the eyes and clothing.
- Consult a doctor immediately if coolant is swallowed.
- Rinse the affected area immediately with plenty of water in the event of contact with the skin.
- Rinse eyes thoroughly with water and consult a doctor immediately if coolant gets into the eyes.
- Change clothing if coolant spills onto your clothing.

### Condition

The motor is cold.

- Position the vehicle vertically on a level surface with the aid of another person.
- Remove the radiator cap.
- Check the coolant level in the radiator.

Coolant level <b>A</b> above the radiator fins	10 mm (0.39 in)
--	-----------------

- » If the coolant level does not match the specified value:

- Correct the coolant level.

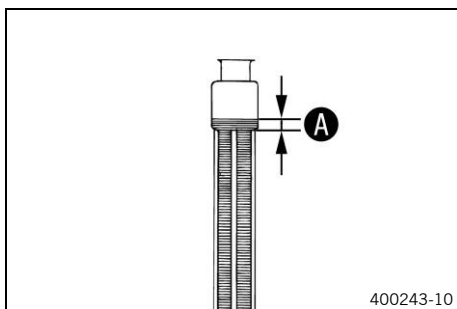

Coolant (📖 p. 143)

- Mount the radiator cap.



## 18.4 Draining the coolant 🛠️



### Warning

**Danger of scalding** During motorcycle operation, the coolant gets very hot and is under pressure.

- Do not remove the radiator cap, radiator hoses or other cooling system components when the motor is hot. Allow the motor and cooling system to cool down. In case of scalding, rinse immediately with lukewarm water.



### Warning

**Danger of poisoning** Coolant is toxic and a health hazard.

- Keep coolant out of the reach of children.
- Do not allow coolant to come into contact with the skin, the eyes and clothing.
- Consult a doctor immediately if coolant is swallowed.
- Rinse the affected area immediately with plenty of water in the event of contact with the skin.
- Rinse eyes thoroughly with water and consult a doctor immediately if coolant gets into the eyes.
- Change clothing if coolant spills onto your clothing.

### Condition

The engine is cold.

### Preparatory work

- Deactivate the vehicle. (📖 p. 43)
- Fold the seat up. (📖 p. 69)
- Remove the Powerpack HV. (📖 p. 108)
- Mount the protection cap. (📖 p. 71)

### Main work

- Position the motorcycle upright.
- Place an appropriate container under the motorcycle.
- Remove screws ① and ② with the seal ring.



### Info

The screws are located under the electric motor and can be accessed through a recess in the motor guard.

- Remove radiator cap ③.
- Completely drain the coolant.
- Mount screws ① and ② with a new seal ring and tighten.

### Guideline

Coolant drain plug	M6	10 Nm (7.4 lbf ft)
--------------------	----	--------------------

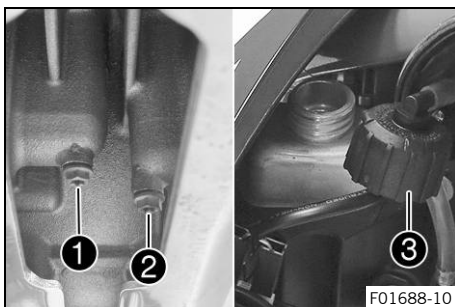

## 18.5 Refilling with coolant



### Warning

**Danger of poisoning** Coolant is toxic and a health hazard.

- Keep coolant out of the reach of children.
- Do not allow coolant to come into contact with the skin, the eyes and clothing.
- Consult a doctor immediately if coolant is swallowed.
- Rinse the affected area immediately with plenty of water in the event of contact with the skin.
- Rinse eyes thoroughly with water and consult a doctor immediately if coolant gets into the eyes.
- Change clothing if coolant spills onto your clothing.

### Condition

The motor is cold.

### Preparatory work

- Deactivate the vehicle. (📖 p. 43)
- Fold the seat up. (📖 p. 69)
- Remove the Powerpack HV. (📖 p. 108)
- Mount the protection cap. (📖 p. 71)

### Main work

- Ensure that the screws ① and ② are tightened.

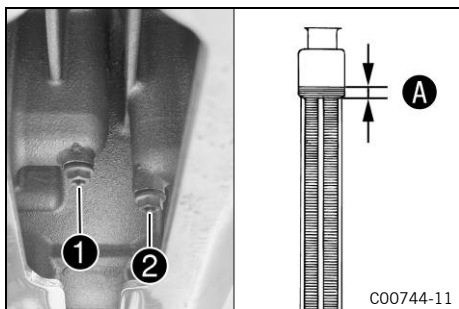

### Info

The screws are located under the electric motor and can be accessed through a recess in the motor guard.

- Position the motorcycle upright.
- Pour coolant in up to measurement A above the radiator fins.

Guideline

10 mm (0.39 in)
-----------------

Coolant	0.7 l (0.7 qt.)	Coolant (📖 p. 143)
---------	-----------------	--------------------

- Mount the radiator cap.

### Finishing work

- Remove the protection cap. (📖 p. 71)
- Install the Powerpack HV. (📖 p. 109)
- Lock the seat. (📖 p. 69)
- Go for a short test ride.
- Check the cooling system for leaks.
- Check the coolant level. (📖 p. 122)

18.6 Changing the coolant



**Warning**

**Danger of scalding** During motorcycle operation, the coolant gets very hot and is under pressure.

- Do not remove the radiator cap, radiator hoses or other cooling system components when the motor is hot. Allow the motor and cooling system to cool down. In case of scalding, rinse immediately with lukewarm water.



**Warning**

**Danger of poisoning** Coolant is toxic and a health hazard.

- Keep coolant out of the reach of children.
- Do not allow coolant to come into contact with the skin, the eyes and clothing.
- Consult a doctor immediately if coolant is swallowed.
- Rinse the affected area immediately with plenty of water in the event of contact with the skin.
- Rinse eyes thoroughly with water and consult a doctor immediately if coolant gets into the eyes.
- Change clothing if coolant spills onto your clothing.

**Condition**

The engine is cold.

**Preparatory work**

- Deactivate the vehicle. (📖 p. 43)
- Fold the seat up. (📖 p. 69)
- Remove the Powerpack HV. (📖 p. 108)
- Mount the protection cap. (📖 p. 71)

**Main work**

- Position the motorcycle upright.
- Place an appropriate container under the motorcycle.
- Remove screws ① and ② with the seal ring.

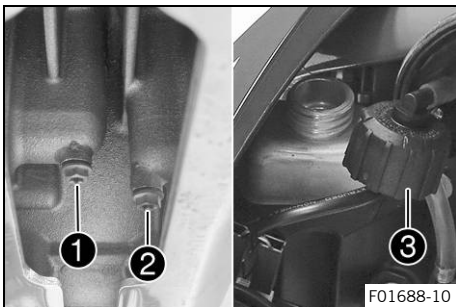

**Info**

The screws are located under the electric motor and can be accessed through a recess in the motor guard.

- Remove radiator cap ③.
- Completely drain the coolant.
- Mount screws ① and ② with a new seal ring and tighten.

**Guideline**

Coolant drain plug	M6	10 Nm (7.4 lbf ft)
--------------------	----	--------------------

- Pour coolant in up to level A above the radiator fins.

**Guideline**

10 mm (0.39 in)
-----------------

Coolant	0.7 l (0.7 qt.)	Coolant (📖 p. 143)
---------	-----------------	--------------------

- Mount the radiator cap.

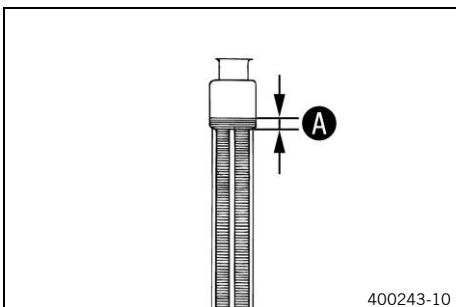

**Finishing work**

- Remove the protection cap. (📖 p. 71)
- Install the Powerpack HV. (📖 p. 109)

- Lock the seat. (📖 p. 69)
- Go for a short test ride.
- Check the cooling system for leaks.
- Check the coolant level. (📖 p. 122)





19.1 Selecting the riding mode

**Condition**

**Alternative 1**

The motorcycle is stationary.  
The motorcycle is ready for operation.

**Alternative 2**

The motorcycle is stationary.  
The motorcycle is ready to drive.

**Alternative 3**

The motorcycle is moving.  
≤ 5 km/h (≤ 3.1 mph)  
The throttle grip is in the basic position.

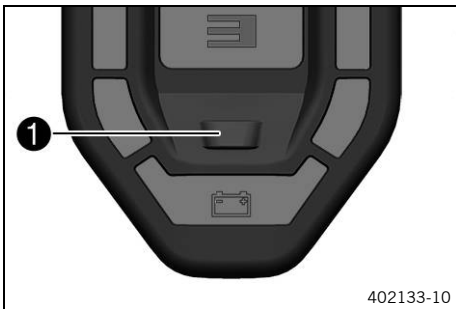

- Press and hold riding mode button **1** for at least one second.
  - ✓ The riding mode is activated when the tip switch is let go.

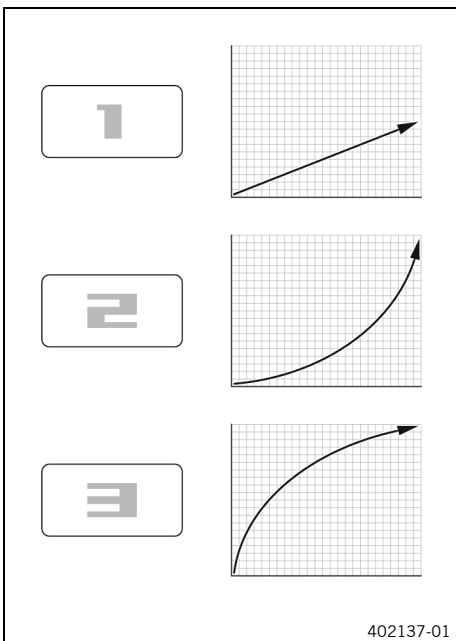

- Select one of the driving modes.
  - The riding mode **1** is Economy: the motor torque is reduced by half.
  - Riding mode **2** is Standard: the further the throttle grip is twisted open, the more the motor power increases.
  - The riding mode **3** is Advanced: the greatest increase in power occurs immediately, after which the motor power increases more slowly.

---

**i Info**  
A red indicator lamp with the number **1**, **2** or **3** shows the riding mode selected.  
Three drive modes are available. The riding modes define how the vehicle will respond to operation of the throttle grip.  
The figures contain approximate values for illustration purposes and do not show the actual response.

---

## 20.1 Changing the gear oil ↴



### Warning

**Danger of scalding** Gear oil becomes very hot when the motorcycle is operating.

- Wear suitable protective clothing and safety gloves.
- If you have been scalded, hold the burn under lukewarm water immediately.



### Note

**Environmental hazard** Hazardous substances cause environmental damage.

- Dispose of oils, grease, cleaning agents, brake fluid etc. properly and in compliance with the applicable regulations.



### Info

Drain the gear oil while the motor is warm.

### Preparatory work

- Stand the motorcycle on a level surface using the side stand.
- Deactivate the vehicle. (🔊 p. 43)
- Fold the seat up. (🔊 p. 69)
- Remove the Powerpack HV. (🔊 p. 108)
- Mount the protection cap. (🔊 p. 71)

### Main work

- Position an appropriate container under the engine.
- Remove oil drain plug ❶ with the magnet and seal ring.

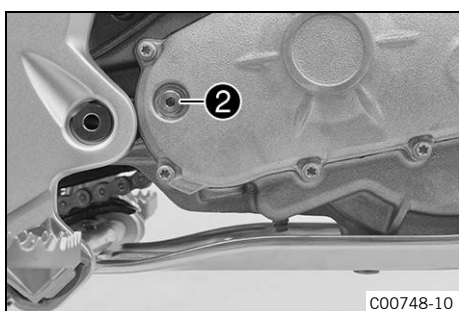
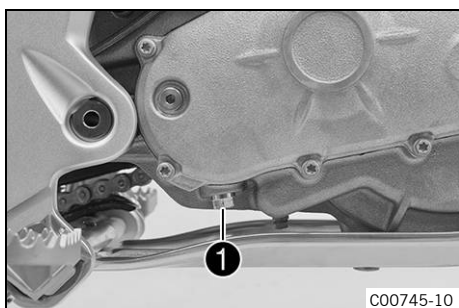

- Remove screw plug ❷ with the seal ring.
- Let the gear oil drain fully.

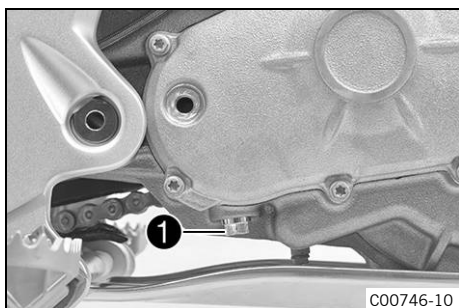

- Mount the oil drain plug ❶ with the magnet and seal ring and tighten it.

#### Guideline

Oil drain plug with magnet	M12x1.5x12	20 Nm (14.8 lbf ft)
----------------------------	------------	---------------------

- Place the motorcycle on its left side with the aid of an assistant.

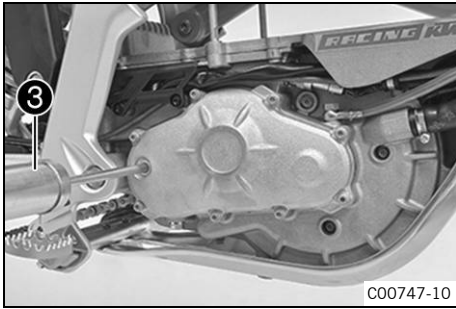

- Fill special tool ③ with the specified quantity of gear oil.

Oil filler syringe (58429048000)		
----------------------------------	--	--

Gear oil	0.2 l (0.2 qt.)	Gear oil (SAE 80W/90) (📖 p. 143)
----------	-----------------	-------------------------------------

- Fill the gear oil using the special tool.
- Wipe away any excess gear oil.



### Info

The screw plug is not used for checking the oil level!

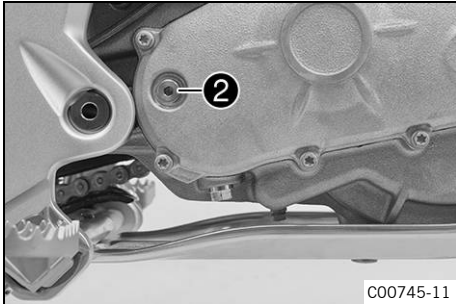

- Mount and tighten screw plug ② with the seal ring.

### Guideline

Oil seal plug	M10	8 Nm (5.9 lbf ft)
---------------	-----	-------------------

- Stand the motorcycle upright.

### Finishing work

- Install the Powerpack HV. (📖 p. 109)
- Lock the seat. (📖 p. 69)
- Go for a short test ride and check the motor has no leaks.



## 21.1 Cleaning the motorcycle

### Note

**Material damage** The vehicle and the Powerpack HV are not suitable for pressure cleaning.

The high pressure forces water into the electrical components, connectors, bearings, etc. As a result, components may be damaged or destroyed.

- Never clean the vehicle and the Powerpack HV with a pressure cleaner or a powerful jet of water.

### Note

**Material damage** Water or dirt damage or destroy components.

- Always mount the protection cap after you have removed the Powerpack HV.
- Do not point the jet of water toward the battery discharge plug, even if the protection cap has been mounted.



### Note

**Environmental hazard** Hazardous substances cause environmental damage.

- Dispose of oils, grease, cleaning agents, brake fluid etc. properly and in compliance with the applicable regulations.



### Info

To maintain the value and appearance of the motorcycle over a long period, clean it regularly. Avoid direct sunshine when cleaning the motorcycle.

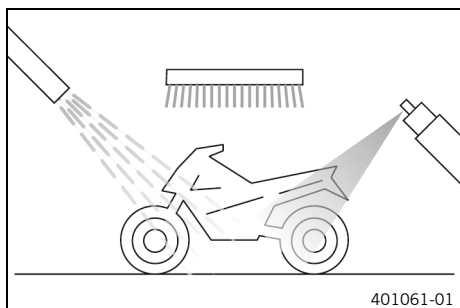

### Preparatory work

- Deactivate the vehicle. (📖 p. 43)
- Fold the seat up. (📖 p. 69)
- Remove the Powerpack HV. (📖 p. 108)
- Mount the protection cap. (📖 p. 71)

### Main work

- Remove the coarse dirt particles with a gentle water jet.
- Spray the heavily soiled parts with a normal commercial motorcycle cleaner and clean using a brush.

Motorcycle cleaner (📖 p. 145)



### Info

Use warm water containing normal motorcycle cleaner and a soft sponge.

Never apply motorcycle cleaner to a dry vehicle; always rinse the vehicle with water first.

- After rinsing the motorcycle with a gentle spray of water, allow it to dry thoroughly.



### Warning

**Danger of accidents** Moisture and dirt impair the brake system.

- Brake carefully several times to dry out and remove dirt from the brake linings and the brake discs.

- Lubricate all sliding points and pivot points.
- Clean the chain. (📖 p. 72)

- Treat bare metal (except for brake discs) with a corrosion inhibitor.

Preserving materials for paints, metal and rubber (📖 p. 145)

- Treat all plastic parts and powder-coated parts with a mild cleaning and care product.

Special cleaner for glossy and matte paint finishes, metal and plastic surfaces (📖 p. 145)

- Oil the steering lock.

Universal oil spray (📖 p. 145)

**Finishing work**

- Install the Powerpack HV. (📖 p. 109)
- Lock the seat. (📖 p. 69)



**21.2 Checks and maintenance steps for winter operation**

**i Info**

If you use the motorcycle in winter, salt can be expected on the roads. You should therefore take precautions against aggressive road salt. If the vehicle was operated in road salt, clean it with cold water after riding. Warm water would enhance the corrosive effects of salt.

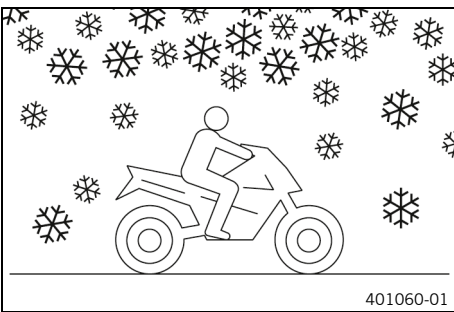

- Clean the motorcycle. (📖 p. 130)
- Clean the brake system.

**i Info**

After **EVERY** trip on salted roads, thoroughly wash the brake calipers and brake linings with cold water and dry carefully. This should be done after the parts are cooled down and while they are installed. After riding on salted roads, thoroughly wash the motorcycle with cold water and dry it well.

- Treat the engine, the link fork, and all other bare or zinc-plated parts (except brake discs) with a wax-based corrosion inhibitor.

**i Info**

Corrosion inhibitor must not come in contact with the brake discs as this would greatly reduce the braking force.

- Clean the chain. (📖 p. 72)



## 22.1 Storage

### **i** Info

If the motorcycle is not being used for an extended length of time, additional measures are recommended. Have service work, repairs or conversions performed outside the motorcycling season, if possible. This allows you to avoid long waiting periods when the next season starts.

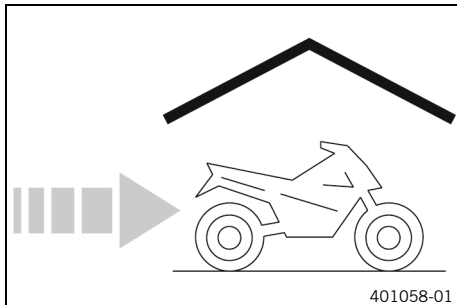

- Empty the Powerpack HV to below 30% charging level.
- Check all motorcycle parts for function and wear.
- Remove the Powerpack HV. (📖 p. 108)
- Mount the protection cap. (📖 p. 71)
- Remove the 12-V battery. 🛠️ (📖 p. 98)
- Charge the Powerpack HV in charging mode **Storage**. (📖 p. 117)

#### Guideline

The service life of the Powerpack HV must not exceed 1 year.	
Ideal storage temperature of the Powerpack HV without direct sunlight	10 ... 20 °C (50 ... 68 °F)

### **i** Info

Never store the Powerpack HV at higher temperatures as this would greatly accelerate the aging process.

- Charge the 12-V battery. 🛠️ (📖 p. 99)

#### Guideline

Storage temperature of the 12-V battery without direct sunlight	0 ... 35 °C (32 ... 95 °F)
---	----------------------------

- Clean the motorcycle. (📖 p. 130)
- Check the antifreeze and coolant level. (📖 p. 121)
- Check tire pressure. (📖 p. 95)
- Store the vehicle in a dry location that is not subject to large fluctuations in temperature.

### **i** Info

If the vehicle is placed on a lift stand, the tires and spring elements will be relieved of weight.

- Raise the motorcycle with a lift stand. (📖 p. 57)
- Cover the vehicle with a tarp or a similar cover that is permeable to air.

### **i** Info

Do not use any non-porous materials, as moisture cannot escape and corrosion can occur.

## 22.2 Preparing for use after storage

### **i** Info

If the Powerpack HV has not been used for more than six months, start by discharging the Powerpack HV until the vehicle switches off with blink code 11. Then fully charge the Powerpack HV.

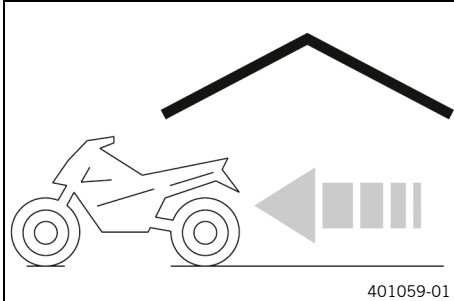

- Remove the motorcycle from the lift stand. (📖 p. 57)
- Install the 12-V battery. 🛠️ (📖 p. 98)
- Install the Powerpack HV. (📖 p. 109)
- Perform checks and maintenance measures when preparing for use. (📖 p. 40)
- Take a test ride.



## 23.1 Vehicle troubleshooting



The malfunctions are indicated by yellow malfunction indicator lamp **1** and by acoustic signals that sound at the same time.

### **i** Tip

The first step to take in case of any malfunction is to switch off the vehicle at the main switch, wait for 15 seconds, and then switch the vehicle back on. If a malfunction is not eliminated by the steps specified here, or a blink code is not listed, an authorized KTM workshop will be happy to help you.

### **i** Info

The pause between the signals of the 1st digit is 0.25 seconds.  
The pause between the 1st and 2nd digits is 1 second.  
The pause between the signals of the 2nd digit is also 0.25 seconds.  
The pause until the blink code repeats is 3 seconds.

Faults	Possible cause	Action
Blink code 11 on the vehicle	Powerpack HV discharged	<ul style="list-style-type: none"> <li>– Charge the Powerpack HV. (📖 p. 113)</li> <li>– Use the charged Powerpack HV.</li> </ul>
Blink code 13 on the vehicle	Malfunction during charging	<ul style="list-style-type: none"> <li>– Stop charging, switch off the main switch, and restart charging.</li> </ul>
Blink code 22 on the vehicle	Overtemperature of the control unit	<ul style="list-style-type: none"> <li>– Check the coolant level. (📖 p. 122)</li> <li>– Check the radiator for dirt.</li> </ul>
Blink code 23 on the vehicle	Overtemperature of the electric motor	<ul style="list-style-type: none"> <li>– Check the coolant level. (📖 p. 122)</li> <li>– Check the radiator for dirt.</li> </ul>
Blink code 24 on the vehicle	Overtemperature of the Powerpack HV	<ul style="list-style-type: none"> <li>– Allow the Powerpack HV to cool down.</li> </ul>
Blink code 31 on the vehicle	Malfunction in the CAN communication	<ul style="list-style-type: none"> <li>– Switch the main switch off and on.</li> <li>– Check the Powerpack HV for correct positioning.</li> <li>– Check the connection of the multifunction display for loose connectors.</li> </ul>
Blink code 33 on the vehicle	Malfunction in the communication with the Powerpack HV	<ul style="list-style-type: none"> <li>– Switch the main switch off and on.</li> <li>– Check the Powerpack HV for correct positioning.</li> </ul>
Blink code 34 on the vehicle	Malfunction in the communication with the multifunction element	<ul style="list-style-type: none"> <li>– Switch the main switch off and on.</li> <li>– Check the connection of the multifunction display for loose connectors.</li> </ul>
Blink code 41 on the vehicle	Malfunction on the throttle grip	<ul style="list-style-type: none"> <li>– Switch the main switch off and on.</li> <li>– Check the throttle grip for external damage.</li> </ul>
Blink code 42 on the vehicle	Malfunction in the rotor position sensor	<ul style="list-style-type: none"> <li>– Switch the main switch off and on.</li> </ul>
Blink code 43 on the vehicle	Malfunction in the Powerpack HV	<ul style="list-style-type: none"> <li>– Switch the main switch off and on.</li> </ul>



Faults	Possible cause	Action
Blink code 44 on the vehicle	Malfunction in the 12 V supply	<ul style="list-style-type: none"> <li>– Charge the 12-V battery. (🔌 p. 99)</li> <li>– Install a new 12 V battery.</li> </ul>
Blink code 45 on the vehicle	Malfunction in the electric motor	<ul style="list-style-type: none"> <li>– Switch the main switch off and on.</li> </ul>
Blink code 46 on the vehicle	Malfunction in the vehicle system wiring harness or in a switch	<ul style="list-style-type: none"> <li>– Switch the main switch off and on.</li> <li>– Check the vehicle system wiring harness and plug-in connectors for external damage.</li> </ul>
Blink code 51 on the vehicle	Malfunction in the electric motor control unit	<ul style="list-style-type: none"> <li>– Switch the main switch off and on.</li> </ul>
Blink code 52 on the vehicle	Malfunction in the moisture monitor	<ul style="list-style-type: none"> <li>– Switch the main switch off and on.</li> </ul>
Blink code 53 on the vehicle	Malfunction in the relay of the Powerpack HV	<ul style="list-style-type: none"> <li>– Switch the main switch off and on.</li> </ul>
Blink code 54 on the vehicle	Malfunction in the insulation monitor	<ul style="list-style-type: none"> <li>– Clean and dry the discharge plug and discharge socket without compressed air.</li> </ul>
Speedometer values deleted (time, stop watch, lap times)	The combination instrument battery is empty	<ul style="list-style-type: none"> <li>– Change combination instrument battery. (🔋 p. 106)</li> </ul>
The high beam, low beam, position light, tail light, and license plate lamp are not working	Fuse <b>3</b> blown	<ul style="list-style-type: none"> <li>– Change the fuses of individual electrical power consumers. (🔌 p. 100)</li> </ul>
The combination instrument, horn, brake light, and turn signal are not working	Fuse <b>4</b> blown	<ul style="list-style-type: none"> <li>– Change the fuses of individual electrical power consumers. (🔌 p. 100)</li> </ul>

## 23.2 Troubleshooting of the battery charger



The malfunctions are indicated by LED ❶ on the battery charger. All of the following blink codes are displayed on the battery charger and refer to the charger itself.

**i Tip**  
The first step to take in case of any malfunction is to switch off the battery charger, wait for 15 seconds, and then switch it back on. If a malfunction is not eliminated by the steps specified here, or a blink code is not listed, an authorized KTM workshop will be happy to help you.

**i Info**  
The pause between the signals of the 1st digit is 0.25 seconds. The pause between the 1st and 2nd digits is 1 second. The pause between the signals of the 2nd digit is also 0.25 seconds. The pause until the blink code repeats is 3 seconds.

Faults	Possible cause	Action
Blink code 11 on battery charger	Malfunction in the charging cable	– Check the charging plug and charging cable for external damage and dirt and reconnect.
Blink code 12 on battery charger	Malfunction in the charging cable	– Check the charging plug and charging cable for external damage and dirt and reconnect.
Blink code 13 on battery charger	Malfunction in the charging cable	– Check the charging plug and charging cable for external damage and dirt and reconnect.
Blink code 51 on battery charger	Overtemperature of the battery charger	– Let the charger cool down. – Continue charging in a cooler location.
Blink code 63 on battery charger	Malfunction in the supply voltage	– Use the <b>Normal</b> charging mode. – Choose a socket closer to the central supply.
Blink code 65 on battery charger	Malfunction in the supply voltage	– Use the <b>Normal</b> charging mode. – Choose a socket closer to the central supply.

23.3 Troubleshooting Powerpack HV on the battery charger



The malfunctions are indicated by LED ❶ on the battery charger. All of the following blink codes are displayed on the battery charger and refer to the Powerpack HV.

**i Tip**  
The first step to take in case of any malfunction is to switch off the battery charger, wait for 15 seconds, and then switch it back on. If a malfunction is not eliminated by the steps specified here, an authorized KTM workshop will be happy to help you.

**i Info**  
The pause between the signals of the 1st digit is 0.25 seconds. The pause between the 1st and 2nd digits is 1 second. The pause between the signals of the 2nd digit is also 0.25 seconds. The pause until the blink code repeats is 3 seconds.

Faults	Possible cause	Action
Blink code 11 on battery charger	Charging fault	– Check the charging plug and charging cable for external damage and dirt and reconnect.
Blink code 33 on battery charger	Overtemperature of the Powerpack HV	– Allow the Powerpack HV to cool down.
Blink code 34 on battery charger	Undertemperature of the Powerpack HV	– Place the Powerpack HV in a warmer location and allow it to warm up. – Continue charging in a warmer location.
Blink code 36 on battery charger	Undertemperature of the Powerpack HV	– Place the Powerpack HV in a warmer location and allow it to warm up. – Continue charging in a warmer location.
Blink code 64 on battery charger	Charging cable detected in activated vehicle	– Switch off the main switch on the vehicle and restart charging.
Blink code 65 on battery charger	Malfunction in the charging cable	– Check the charging plug and charging cable for external damage and dirt and reconnect.
Blink code 66 on battery charger	Powerpack HV charging level too high for charging mode <b>Storage</b>	– Empty the Powerpack HV to below 30%.
Blink code 73 on battery charger	Powerpack HV not enabled	– Contact an authorized KTM workshop.

## 24.1 Engine

Primary transmission	1:2.4
Cooling	Water cooling, permanent circulation of coolant by electric water pump

## 24.2 Engine tightening torques

Coolant drain plug	M6	10 Nm (7.4 lbf ft)
Oil seal plug	M10	8 Nm (5.9 lbf ft)
Oil drain plug with magnet	M12x1.5x12	20 Nm (14.8 lbf ft)

## 24.3 Capacities

### 24.3.1 Gear oil

Gear oil	0.2 l (0.2 qt.)	Gear oil (SAE 80W/90) (📖 p. 143)
----------	-----------------	----------------------------------

### 24.3.2 Coolant

Coolant	0.7 l (0.7 qt.)	Coolant (📖 p. 143)
---------	-----------------	--------------------

## 24.4 Chassis

Frame	Perimeter, steel-aluminum composite frame	
Fork	<b>WP XPLOR 5343</b>	
Suspension travel		
front	250 mm (9.84 in)	
rear	260 mm (10.24 in)	
Fork offset	20 mm (0.79 in)	
Shock absorber	<b>WP XPLOR 5746</b>	
Brake system	Disc brakes, floating brake calipers	
Brake discs - diameter		
front	240 mm (9.45 in)	
rear	220 mm (8.66 in)	
Brake discs - wear limit		
front	3.5 mm (0.138 in)	
rear	3.5 mm (0.138 in)	
Offroad tire pressure		
front	0.9 bar (13 psi)	
rear	0.7 bar (10 psi)	
Street tire pressure		
front	2 bar (29 psi)	
rear	2 bar (29 psi)	
Secondary ratio	11:48	
Chain	5/8 x 1/4" X-ring	
Rear sprockets available	46, 48	
Steering head angle	67°	
Wheelbase	1,418 ± 10 mm (55.83 ± 0.39 in)	

Ground clearance, unloaded	340 mm (13.39 in)
Seat height, unloaded	910 mm (35.83 in)
Homologated weight with Powerpack HV approx.	111 kg (245 lb.)
Maximum permissible front axle load	110 kg (243 lb.)
Maximum permissible rear axle load	170 kg (375 lb.)
Maximum permissible overall weight	280 kg (617 lb.)

## 24.5 Electrical system

12-V battery	LFP01	Battery voltage: 12 V Nominal capacity: 2.0 Ah Maintenance-free
Combination instrument battery	CR 2430	Battery voltage: 3 V
Air-cooled lithium-ion battery (Powerpack HV)	70145053000	End of charging voltage: 300 V Voltage (nominal): 260 V Capacity: 3.9 kWh Weight: 29 kg (64 lb.) Approx. charging time in charging mode <b>Fast</b> , 0 % to 80 %: 75 min Approx. charging time in charging mode <b>Fast</b> , 0 % to 100 %: 105 min Approx. charging time in charging mode <b>Normal</b> , 0 % to 80 %: 90 min Approx. charging time in charging mode <b>Normal</b> , 0 % to 100 %: 135 min Maintenance-free
Battery charger for Powerpack HV (Option: Battery charger 1)	70029074000	Nominal voltage: 230 V Grid frequency: 50 Hz Power: 3,000 W
Battery charger for Powerpack HV (Option: Battery charger 2)	70145074044	Nominal voltage: 230 V Grid frequency: 50 Hz Power: 3,000 W
Fuse	75011088010	10 A
Fuse	75011088020	20 A
Headlight	HS1 / socket PX43t	12 V 35/35 W
Position light	W5W / socket W2.1x9.5d	12 V 5 W
Indicator lamps	W2.3W / socket W2x4.6d	12 V 2.3 W
Turn signal	R10W/socket BA15s	12 V 10 W
Brake/tail light	LED	
License plate lamp	W5W/socket W2.1x9.5d	12 V 5 W

## 24.6 Tires

Front tire	Rear tire
<b>2.75 - 21 M/C 45M TT</b> MAXXIS TRIALMAXX	<b>4.00 R 18 M/C 64M TL</b> MAXXIS TRIALMAXX
The tires specified represent one of the possible series production tires. Additional information is available in the Service section under: KTM.com	

## 24.7 Fork

Fork article number	05.18.8U.40	
Fork	<b>WP XPLOR 5343</b>	
Compression damping		
Comfort	18 clicks	
Standard	15 clicks	
Sport	12 clicks	
Rebound damping		
Comfort	18 clicks	
Standard	15 clicks	
Sport	12 clicks	
Spring length with preload spacer(s)	427 mm (16.81 in)	
Spring rate		
Weight of rider: 65 ... 75 kg (143 ... 165 lb.)	4.6 N/mm (26.3 lb/in)	
Weight of rider: 75 ... 85 kg (165 ... 187 lb.)	4.8 N/mm (27.4 lb/in)	
Weight of rider: 85 ... 95 kg (187 ... 209 lb.)	5.0 N/mm (28.6 lb/in)	
Fork length	845 mm (33.27 in)	
Fork oil per fork leg	383 ± 5 ml (12.95 ± 0.17 fl. oz.)	Fork oil (SAE 4) (48601166S1) (📖 p. 143)

## 24.8 Shock absorber

Shock absorber article number	12.18.7T.40	
Shock absorber	<b>WP XPLOR 5746</b>	
Low-speed compression damping		
Comfort	18 clicks	
Standard	15 clicks	
Sport	12 clicks	
High-speed compression damping		
Comfort	2 turns	
Standard	2 turns	
Sport	1.5 turns	
Rebound damping		
Comfort	18 clicks	
Standard	15 clicks	
Sport	12 clicks	
Spring preload	9 mm (0.35 in)	

Spring rate	
Weight of rider: 65 ... 75 kg (143 ... 165 lb.)	66 N/mm (377 lb/in)
Weight of rider: 75 ... 85 kg (165 ... 187 lb.)	68 N/mm (388 lb/in)
Weight of rider: 85 ... 95 kg (187 ... 209 lb.)	69 N/mm (394 lb/in)
Spring length	200 mm (7.87 in)
Gas pressure	10 bar (145 psi)
Static sag	25 mm (0.98 in)
Riding sag	115 mm (4.53 in)
Fitted length	367 mm (14.45 in)
Damper oil	Shock absorber fluid (SAE 2.5) (50180751S1) (🗨️ p. 144)

## 24.9 Chassis tightening torques

Hose clamp, radiator	-	2.4 Nm (1.77 lbf ft)
Screw, chain guard on chain sliding guard	<b>EJOT PT®</b> K60x20	2 Nm (1.5 lbf ft)
Screw, combination instrument on combination instrument bracket	<b>EJOT DELTA PT®</b> 45x12-Z	1 Nm (0.7 lbf ft)
Screw, side cover	<b>EJOT PT®</b> K60x20	2 Nm (1.5 lbf ft)
Screw, spoiler	<b>EJOT PT®</b> K60x20AL	2 Nm (1.5 lbf ft)
Screw, on and off switch	M3	0.4 Nm (0.3 lbf ft)
Screw, fixed grip	M4	5 Nm (3.7 lbf ft) <b>Loctite®243™</b>
Spoke nipple	M4.5	6 Nm (4.4 lbf ft)
Clamp, wiring harness on engine	M5	6 Nm (4.4 lbf ft)
Remaining nuts, chassis	M5	5 Nm (3.7 lbf ft)
Remaining screws, chassis	M5	5 Nm (3.7 lbf ft)
Screw, battery terminal	M5	2.5 Nm (1.84 lbf ft)
Screw, cable cover on engine	M5	6 Nm (4.4 lbf ft)
Screw, shock absorber adjusting ring	M5	5 Nm (3.7 lbf ft)
Screws, throttle grip	M5	3 Nm (2.2 lbf ft)
Attaching Powerpack HV	M6	10 Nm (7.4 lbf ft)
Remaining nuts, chassis	M6	10 Nm (7.4 lbf ft)
Remaining screws, chassis	M6	10 Nm (7.4 lbf ft)
Screw for spoiler attachment	M6	6 Nm (4.4 lbf ft)
Screw, front brake disc	M6	14 Nm (10.3 lbf ft) <b>Loctite®243™</b>
Screw, radiator bracket	M6	6 Nm (4.4 lbf ft)
Screw, rear brake disc	M6	14 Nm (10.3 lbf ft) <b>Loctite®243™</b>
Nut, rear sprocket screw	M8	35 Nm (25.8 lbf ft) <b>Loctite®2701™</b>
Nut, rim lock	M8	10 Nm (7.4 lbf ft)
Remaining nuts, chassis	M8	25 Nm (18.4 lbf ft)
Remaining screws, chassis	M8	25 Nm (18.4 lbf ft)

Screw, bottom triple clamp	M8	18 Nm (13.3 lbf ft)	
Screw, chain sliding piece	M8	15 Nm (11.1 lbf ft)	
Screw, fork stub	M8	15 Nm (11.1 lbf ft)	
Screw, front brake caliper	M8	25 Nm (18.4 lbf ft)	<b>Loctite®243™</b>
Screw, handlebar clamp	M8	20 Nm (14.8 lbf ft)	
Screw, rear brake caliper	M8	25 Nm (18.4 lbf ft)	<b>Loctite®243™</b>
Screw, rear engine sprocket cover	M8	15 Nm (11.1 lbf ft)	
Screw, side stand attachment	M8	25 Nm (18.4 lbf ft)	<b>Loctite®243™</b>
Screw, subframe	M8	30 Nm (22.1 lbf ft)	<b>Loctite®243™</b>
Screw, top steering stem	M8	17 Nm (12.5 lbf ft)	<b>Loctite®243™</b>
Screw, top triple clamp	M8	22 Nm (16.2 lbf ft)	
Screw, wheel speed sensor	M8	4.5 Nm (3.32 lbf ft)	
Shoulder bolt for attaching Powerpack HV	M8	15 Nm (11.1 lbf ft)	<b>Loctite®243™</b>
Motor bracket screw	M10	60 Nm (44.3 lbf ft)	
Remaining nuts, chassis	M10	45 Nm (33.2 lbf ft)	
Remaining screws, chassis	M10	45 Nm (33.2 lbf ft)	
Screw, cross bar	M10	45 Nm (33.2 lbf ft)	
Screw, footrest bracket	M10	45 Nm (33.2 lbf ft)	<b>Loctite®243™</b>
Screw, handlebar support	M10	40 Nm (29.5 lbf ft)	<b>Loctite®243™</b>
Screw, motor guard	M10	30 Nm (22.1 lbf ft)	
Screw, subframe top	M10	45 Nm (33.2 lbf ft)	<b>Loctite®243™</b>
Screw, bottom shock absorber	M12	80 Nm (59 lbf ft)	<b>Loctite®2701™</b>
Screw, top shock absorber	M12	80 Nm (59 lbf ft)	<b>Loctite®2701™</b>
Nut, swingarm pivot	M14x1.5	75 Nm (55.3 lbf ft)	
Nut, rear wheel spindle	M20x1.5	80 Nm (59 lbf ft)	
Screw, front wheel spindle	M20x1.5	35 Nm (25.8 lbf ft)	
Screw, top steering head	M20x1.5	12 Nm (8.9 lbf ft)	



**Brake fluid DOT 4 / DOT 5.1****Standard/classification**

- DOT

**Guideline**

- Use only brake fluid that complies with the specified standard (see specifications on the container) and that exhibits the corresponding properties.

**Recommended supplier****Castrol**

- REACT PERFORMANCE DOT 4

**MOTOREX®**

- Brake Fluid DOT 5.1

**Coolant****Guideline**

- Only use high-grade, silicate-free coolant with corrosion inhibitor additive for aluminum motors. Low grade and unsuitable antifreeze causes corrosion, deposits and frothing.
- Do not use pure water as only coolant is able to meet the requirements needed in terms of corrosion protection and lubrication properties.
- Only use coolant that complies with the requirements stated (see specifications on the container) and that has the relevant properties.

Antifreeze protection to at least	-25 °C (-13 °F)
-----------------------------------	-----------------

The mixture ratio must be adjusted to the necessary antifreeze protection. Use distilled water if the coolant needs to be diluted.

The use of premixed coolant is recommended.

Observe the coolant manufacturer specifications for antifreeze protection, dilution and miscibility (compatibility) with other coolants.

**Recommended supplier****MOTOREX®**

- COOLANT M3.0

**Fork oil (SAE 4) (48601166S1)****Standard/classification**

- SAE (📖 p. 146) (SAE 4)

**Guideline**

- Use only oils that comply with the specified standards (see specifications on the container) and that exhibit the corresponding properties.

**Gear oil (SAE 80W/90)****Standard/classification**

- SAE (📖 p. 146) (SAE 80W/90)

**Guideline**

- Use only gear oils that comply with the specified standards (see specifications on the container) and that exhibit the required properties.

Semi-synthetic gear oil
-------------------------

**Recommended supplier****MOTOREX®**

- Gear Oil

### Shock absorber fluid (SAE 2.5) (50180751S1)

**Standard/classification**

- SAE (📖 p. 146) (SAE 2.5)

**Guideline**

- Use only oils that comply with the specified standards (see specifications on the container) and that exhibit the corresponding properties.

**Chain cleaner**

Recommended supplier

MOTOREX®

- Chain Clean

**High viscosity grease**

Recommended supplier

SKF®

- LGHB 2

**Long-life grease**

Recommended supplier

MOTOREX®

- Bike Grease 2000

**Motorcycle cleaner**

Recommended supplier

MOTOREX®

- Moto Clean

**Off-road chain spray**

Recommended supplier

MOTOREX®

- Chainlube Offroad

**Preserving materials for paints, metal and rubber**

Recommended supplier

MOTOREX®

- Moto Protect

**Special cleaner for glossy and matte paint finishes, metal and plastic surfaces**

Recommended supplier

MOTOREX®

- Quick Cleaner

**Universal oil spray**

Recommended supplier

MOTOREX®

- Joker 440 Synthetic

### SAE

The SAE viscosity classes were defined by the Society of Automotive Engineers and are used for classifying oils according to their viscosity. The viscosity describes only one property of oil and says nothing about quality.

BIN	Battery identification number	Serial number of the Powerpack; this is linked to the vehicle's identification number
-----	-------------------------------	---

## 29 LIST OF ABBREVIATIONS

Art. no.	Article number
ca.	circa
cf.	compare
e.g.	for example
etc.	et cetera
i.a.	inter alia
no.	number
poss.	possibly



### 30.1 Yellow and orange symbols

Yellow and orange symbols indicate an error condition that requires prompt intervention. Active driving aids are also represented by yellow or orange symbols.

	The malfunction indicator lamp flashes – There is a malfunction in the vehicle electronic system.
---	---

### 30.2 Green and blue symbols

Green and blue symbols reflect information.

	The high beam indicator lamp lights up blue – The high beam is switched on.
	Turn signal indicator lamp flashes green – The turn signal is switched on.



READY TO RACE

# RESCUE CARD

KTM Freeride E  
2022



Model example



112 European emergency number

Technical emergency number .....  
<http://www.ktm.com/rescuecard>

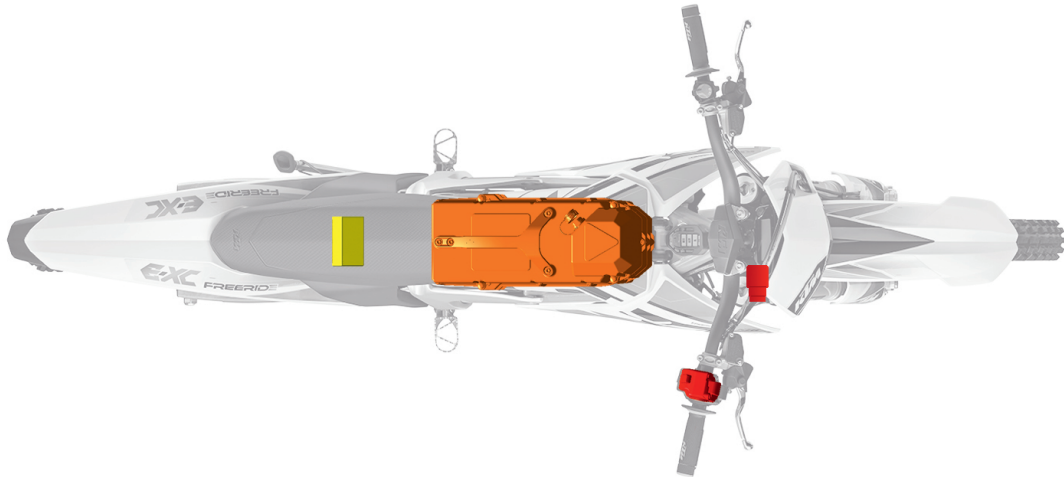

Main switch

Ignition lock

High-voltage cabling in motor housing

Powerpack HV (high-voltage battery, 260 V)

12-V battery for onboard network

Art. no. 3214433en  
02.2021





## General information

- The KTM Freeride E is a high-voltage electric motorcycle with a lithium-ion battery (Powerpack HV, 260 V).
- The high-voltage components in the vehicle are identified by yellow warning labels.
- The high-voltage cables in the motor housing and in the Powerpack HV can be identified by the orange color of their insulation.
- Before beginning work on the vehicle, switch off main switch ❶ to the right of the handlebar and ignition lock ❷ on the right behind the head-light mask . ☒

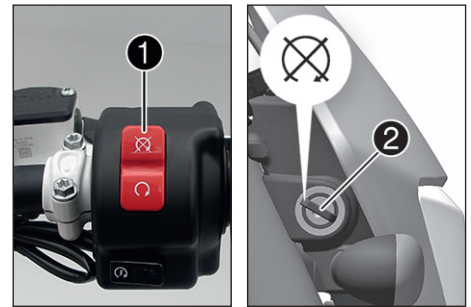

## Version 1: Lightly damaged vehicle

**(Orange high-voltage cable is not visible, no visible damage to Powerpack HV)**

1. Switch off main switch ❶ and ignition lock ❷ ☒.
2. Unlock the seat ❸ and fold it up.
3. Disconnect the 12-V battery ❹.
4. Loosen the hex screws size 10 ❺.
5. Remove the Powerpack HV ❻.

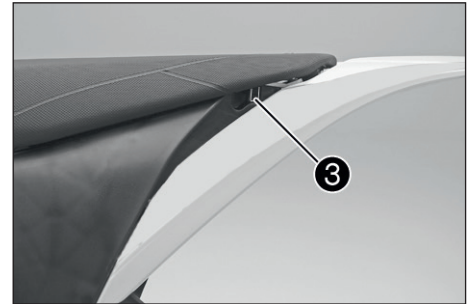

## Version 2: Severely damaged vehicle

**(Orange high-voltage cable is visible and/or metallic penetration of the Powerpack HV)**

**i** The intrinsic safety of the high-voltage system of the vehicle cannot be determined from the outside.

**⚠** Using suitable high-voltage protective equipment, the vehicle must be de-energized by removing the Powerpack HV (high-voltage battery).

**⚠** The following steps must be performed by persons with high-voltage training only!

1. Switch off main switch ❶ and ignition lock ❷ ☒.
2. Unlock the seat ❸ and fold it up.
3. Disconnect the 12-V battery ❹.
4. Loosen the hex screws size 10 ❺.
5. Removing the Powerpack HV (high-voltage battery, 260 V) ❻.
6. Securing the Powerpack HV.
7. Contacting KTM Customer Service.

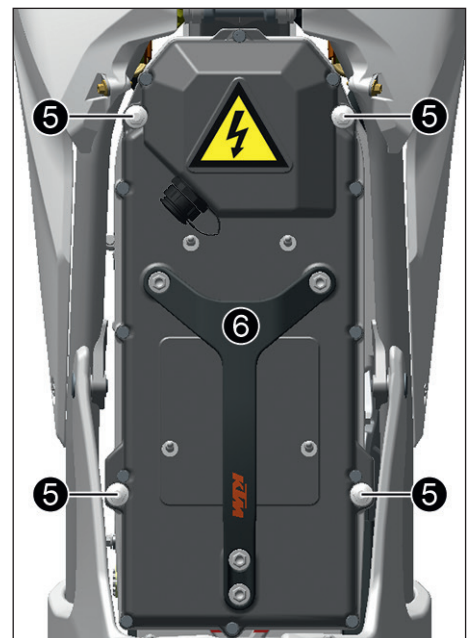

## Version 3: Vehicle fire

- Contact the fire rescue service and inform them that a vehicle with a lithium-ion battery is on fire.
- In the event of a vehicle fire, the usual regulations for low-voltage systems apply.
- If the Powerpack HV was affected by the fire, the extinguishing and cooling process may take up to 24 hours. The surroundings must be protected accordingly.
- To cool a burning Powerpack HV, use large quantities of water.
- When using branch pipes and water as an extinguishing agent, maintain a safety distance of **1 m for spraying** and **5 m for a full jet of water**.



<b>1</b>	
<b>12-V battery</b>	
charging	99
installing	98
removing	98
<b>A</b>	
<b>Accessories</b>	13
<b>Accident</b>	10
<b>Antifreeze</b>	
checking	121
<b>Auxiliary substances</b>	13
<b>B</b>	
<b>Basic chassis setting</b>	
checking with rider's weight	47
<b>Battery charger</b>	
overview	110-111
positioning	111
<b>Battery discharge plug form ring</b>	
checking	71
<b>Brake discs</b>	
checking	79
<b>Brake fluid</b>	
of front brake, adding	81
of rear brake, adding	86
<b>Brake fluid level</b>	
of front brake, checking	80
of rear brake, checking	86
<b>Brake linings</b>	
front brake, changing	83
front brake, checking	82
of the rear brake, changing	88
rear brake, checking	88
<b>Brake system</b>	79-90
<b>C</b>	
<b>Capacity</b>	
coolant	124-125, 138
gear oil	129, 138
<b>Chain</b>	
checking	75
cleaning	72
dirt, checking for	72
<b>Chain guide</b>	
checking	75
<b>Chain tension</b>	
adjusting	74
checking	73
<b>Charge level indicator</b>	24
<b>Charging socket protection cap</b>	
changing	120
<b>Combination instrument</b>	
combination instrument battery, changing	106
kilometers or miles, setting	27
lap time, viewing	29
overview	27
setting	28
setting the clock	29
<b>Compression damping</b>	
fork, adjusting	54
<b>Coolant</b>	
draining	123
refilling	124
<b>Coolant level</b>	
checking	121-122
<b>Cooling system</b>	121
<b>Customer service</b>	13
<b>D</b>	
<b>Diagnostic connection</b>	107
<b>Driving mode display</b>	24
<b>E</b>	
<b>Engine sprocket</b>	
checking	75
<b>Environment</b>	11
<b>F</b>	
<b>Fall</b>	10
<b>Figures</b>	13
<b>Fire hazard</b>	12
<b>Fork legs</b>	
basic setting, checking	53
bleeding	58
dust boots, cleaning	59
installing	61
removing	60
<b>Fork protector</b>	
installing	59
removing	58
<b>Frame</b>	
checking	77
<b>Front brake lever</b>	19
free travel, adjusting	79
free travel, checking	79
<b>Front fender</b>	
installing	67
removing	66
<b>Front wheel</b>	
installing	91
removing	91

<b>Fuel, oils, etc.</b> .....	13	lift stand, raising with .....	57
<b>Fuses</b>		lift stand, removing from .....	57
of individual electrical power consumers,		<b>Multifunctional element</b> .....	23
changing .....	100	overview .....	23
<b>G</b>		<b>O</b>	
<b>Gear oil</b>		<b>Operation</b>	
changing .....	128	at low temperatures .....	14
<b>H</b>		<b>Overview of indicator lamps</b> .....	26
<b>Handlebar position</b> .....	55	<b>Overview of indicator lights</b> .....	26
adjusting .....	56	<b>Owner's Manual</b> .....	12
<b>Headlight</b>		<b>P</b>	
range, adjusting .....	105	<b>Power reduction</b> .....	25
<b>Headlight bulb</b>		<b>Power supply</b> .....	14
changing .....	103	<b>Powerpack HV</b>	
<b>Headlight mask with headlight</b>		battery identification number (BIN) .....	18
installing .....	102	charging .....	113
removing .....	102	charging in <b>Storage</b> charging mode .....	117
<b>Headlight setting</b>		installing .....	109
checking .....	105	new .....	14
<b>High-speed compression damping</b>		removing .....	108
shock absorber, adjusting .....	48	transport .....	44
<b>Horn button</b> .....	20	work .....	11
<b>I</b>		<b>Preparing for use</b>	
<b>Ignition lock</b> .....	21	advice on preparing for first use .....	39
<b>Implied warranty</b> .....	13	after storage .....	133
<b>Intended use</b> .....	6	checks and maintenance measures when	
<b>K</b>		preparing for use .....	40
<b>Key number</b> .....	17	<b>Protection cap</b>	
<b>L</b>		mounting .....	71
<b>Light switch</b> .....	20	removing .....	71
<b>Link fork</b>		<b>Protective clothing</b> .....	11
checking .....	77	<b>R</b>	
<b>Lower triple clamp</b>		<b>Rear brake lever</b> .....	19
installing .....	62	free travel, adjusting .....	86
removing .....	61	free travel, checking .....	85
<b>Low-speed compression damping</b>		<b>Rear sprocket</b>	
shock absorber, adjusting .....	47	checking .....	75
<b>M</b>		<b>Rear wheel</b>	
<b>Main switch</b> .....	19	installing .....	93
<b>Malfunction indicator lamp</b> .....	24	removing .....	92
<b>Manufacturer warranty</b> .....	13	<b>Rebound damping</b>	
<b>Misuse</b> .....	6	fork, adjusting .....	54
<b>Motor</b>		shock absorber, adjusting .....	49
work .....	11	<b>Rechargeable lithium-ion battery</b>	
<b>Motor number</b> .....	17	transport .....	44
<b>Motorcycle</b>		work .....	11
cleaning .....	130	<b>Recuperation</b> .....	42
		<b>Residual current protection switch</b>	
		checking .....	113

<b>Riding mode</b>		
selection	.....	127
<b>Riding mode button</b>	.....	23
<b>Riding sag</b>		
adjusting	.....	53
<b>Rubber grip</b>		
checking	.....	78
<b>S</b>		
<b>Safe operation</b>	.....	10
<b>Safety advice</b>	.....	7
<b>Seat</b>		
folding up	.....	69
locking	.....	69
<b>Service</b>	.....	13
<b>Service schedule</b>	.....	45-46
<b>Shock absorber</b>		
installing	.....	68
removing	.....	68
riding sag, checking	.....	51
spring preload, adjusting	.....	52
static sag, checking	.....	51
<b>Side stand</b>	.....	21
<b>Spare parts</b>	.....	13
<b>Spoiler</b>		
installing	.....	70
removing	.....	69
<b>Spoke tension</b>		
checking	.....	96
<b>Start button</b>	.....	20
<b>Starting</b>	.....	40
<b>Steering</b>		
locking	.....	22
unlocking	.....	22
<b>Steering head bearing</b>		
greasing	.....	66
<b>Steering head bearing play</b>		
checking	.....	64
setting	.....	65
<b>Storage</b>	.....	132-133
<b>T</b>		
<b>Technical data</b>		
capacities	.....	138
chassis	.....	138
chassis tightening torques	.....	141
electrical system	.....	139
engine	.....	138
engine tightening torques	.....	138
fork	.....	140
shock absorber	.....	140
tires	.....	140
<b>Throttle grip</b>	.....	19
<b>Tire condition</b>		
checking	.....	95
<b>Tire pressure</b>		
checking	.....	95
<b>Troubleshooting</b>	.....	134-137
battery charger	.....	136
Powerpack HV on battery charger	.....	137
vehicle	.....	134
<b>Turn signal bulb</b>		
changing	.....	104
<b>Turn signal switch</b>	.....	21
<b>Type label</b>	.....	17
<b>U</b>		
<b>Use definition</b>	.....	6
<b>V</b>		
<b>Vehicle</b>		
deactivating	.....	43
transport	.....	44
work	.....	11
<b>Vehicle identification number</b>	.....	17
<b>View of vehicle</b>		
front left	.....	15
rear right	.....	16
<b>W</b>		
<b>Warning labels</b>	.....	7
<b>Winter operation</b>		
checks and maintenance steps	.....	131



3214428en

02/2021

