

125 SX  
150 SX  
125 XC

ART. NO. 3214496EN





Perform the work described in these setup instructions before the vehicle is delivered to the customer.

Read the setup instructions in their entirety before beginning work.

These setup instructions were written to correspond to the latest state of this series. We reserve the right to make changes in the interest of technical advancement without at the same time updating this manual. We shall not provide a description of general workshop methods. Likewise, safety rules that apply in a workshop are not specified here. It is assumed that the work will be performed by a fully trained mechanic.

All specifications contained herein are non-binding. KTM Sportmotorcycle GmbH specifically reserves the right to modify or delete technical specifications, prices, colors, forms, materials, services, designs, equipment, etc., without prior notice and without specifying reasons, to adapt these to local conditions, as well as to stop production of a particular model without prior notice. KTM accepts no liability for delivery options, deviations from figures and descriptions, misprints, and other errors. The models portrayed partly contain special equipment that does not belong to the regular scope of supply.

© 2021 KTM Sportmotorcycle GmbH, Mattighofen Austria

All rights reserved

Reproduction, even in part, as well as copying of all kinds, is permitted only with the express written permission of the copyright owner.



ISO 9001(12 100 6061)

KTM applies quality assurance processes that lead to the highest possible product quality as defined in the ISO 9001 international quality management standard.

Issued by: TÜV Management Service

REG.NO. 12 100 6061

KTM Sportmotorcycle GmbH  
Stallhofnerstraße 3  
5230 Mattighofen, Austria

This document is valid for the following models:

125 SX (F6101V0)

150 SX (F6101V1)

125 XC US (F6175V3)



# 1 MEANS OF REPRESENTATION

## 1.1 Symbols used

The meaning of specific symbols is described below.



Indicates an expected reaction (e.g. of a work step or a function).



Indicates an unexpected reaction (e.g. of a work step or a function).



Indicates a page reference (more information is provided on the specified page).



Indicates information with more details or tips.



Indicates the result of a testing step.



Indicates a voltage measurement.



Indicates a current measurement.



Indicates a resistance measurement.



Indicates the end of an activity including potential rework.

## 1.2 Formats used

The typographical formats used in this document are explained below.

**Proprietary name**

Indicates a proprietary name.

**Name®**

Indicates a protected name.

**Brand™**

Indicates a brand available on the open market.

**Underlined terms**

Refer to technical details of the vehicle or indicate technical terms, which are explained in the glossary.

## 2.1 Unpacking and setting up the vehicle

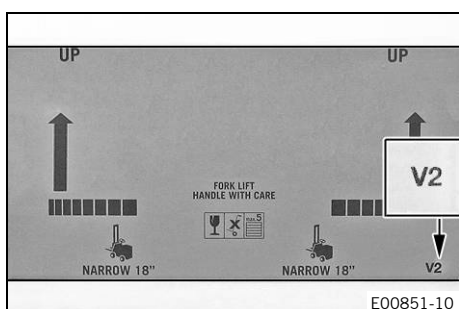

### Package 2

- Remove the box and the plastic packaging.



#### Info

To avoid damaging the motorcycle during the setup, leave the protective film on the vehicle until you have finished.

- Remove the separate enclosure and unpack it. Check that the scope of supply is complete using the enclosed packing list.



#### Info

The procedure for missing components is described in the Customer Service Manual.

- Have a lift stand available.

Lift stand (78129955100)

- Carefully loosen and remove the tension belt of the footrest mount.



#### Info

An assistant prevents the motorcycle from falling over.

- Together with an assistant, take the vehicle off the pallet.
- Position the vehicle on a lift stand.
- Check the vehicle for transport damage.



#### Info

The procedure in the event of transport damage is described in the Customer Service Manual.

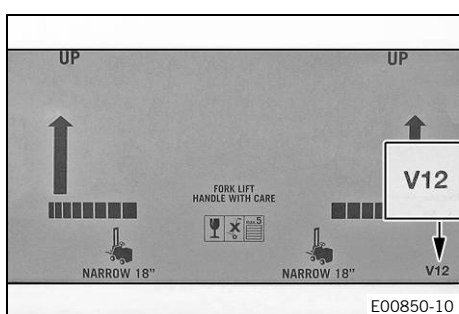
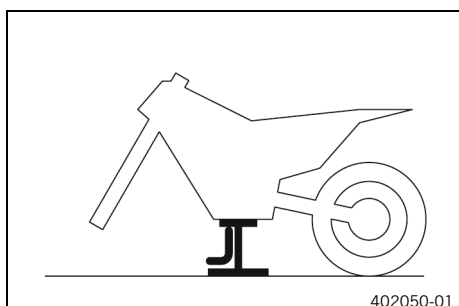

### Package 12

- Remove the box and the plastic packaging.



#### Info

An assistant prevents the motorcycle from falling over.  
To avoid damaging the motorcycle during the setup, leave the protective film on the vehicle until you have finished.

- Remove the separate enclosure and unpack it. Check that the scope of supply is complete using the enclosed packing list.



#### Info

The procedure for missing components is described in the Customer Service Manual.

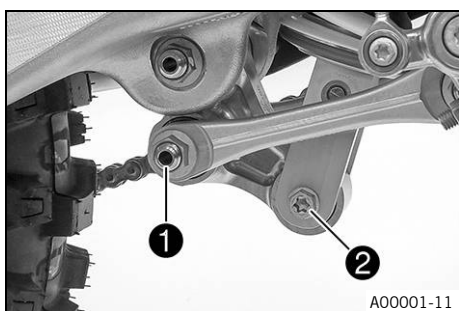
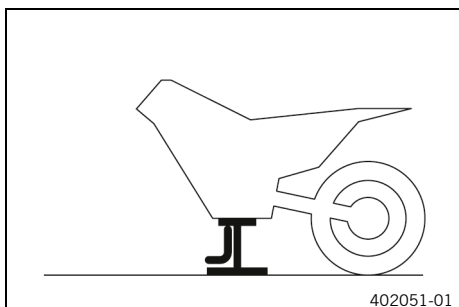

- Have a lift stand available.

Lift stand (78129955100)
--------------------------

- Together with an assistant, take the vehicle off the pallet.
- Position the vehicle on a lift stand.
- Check the vehicle for transport damage.

---

**i Info**  
The procedure in the event of transport damage is described in the Customer Service Manual.

---

- Remove the cardboard from around the shock absorber.
- Position the angle lever and linkage lever.
- Mount and tighten fitting **1**.

Guideline

Nut, linkage lever on angle lever	M14x1.5	60 Nm (44.3 lbf ft)
-----------------------------------	---------	---------------------

- Mount and tighten screw **2**.

Guideline

Screw, bottom shock absorber	M10	60 Nm (44.3 lbf ft) <b>Loctite®2701™</b>
------------------------------	-----	---

---

**i Info**  
Raise the wheel slightly to be able to mount the screw more easily.

---

- Route the clutch line with the clutch master cylinder toward the front between the upper and lower triple clamps.
- Install the fork legs. (📖 p. 13)

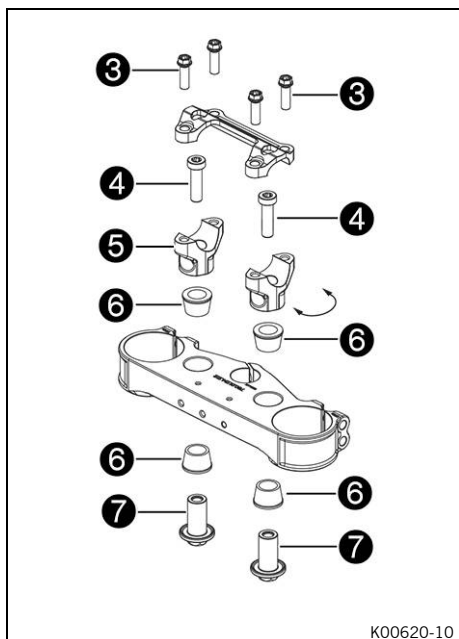

- Remove screws **3**. Take off the handlebar clamp. Remove the handlebar and lay it to one side.

**i Info**  
Cover the components to protect them against damage. Do not kink the cables and lines.

- Remove screws **4**. Take off handlebar supports **5**.
- Position rubber bushings **6** and push through nuts **7** from below.
- Place handlebar supports in required position.

**i Info**  
The handlebar supports are longer and higher on one side. Position the left and right handlebar supports evenly.

- Mount and tighten screws **4**.

Guideline

Screw, handlebar support	M10	40 Nm (29.5 lbf ft) <b>Loctite®243™</b>
--------------------------	-----	--

**! Warning**  
**Danger of accidents** A repaired handlebar poses a safety risk.  
If the handlebar is bent or straightened, the material becomes fatigued. The handlebar may break as a result.  
- Change the handlebar if the handlebar is damaged or bent.

- Position the handlebar.

**i Info**  
Make sure the cables and wiring are positioned correctly.

- Position the handlebar clamp.
- Mount screws **3**, but do not tighten yet.
- First bolt the handlebar clamp with screws **3** onto the longer, higher side of the handlebar supports so that both parts touch.
- Tighten screws **3** evenly.

Guideline

Screw, handlebar clamp	M8	20 Nm (14.8 lbf ft)
------------------------	----	---------------------

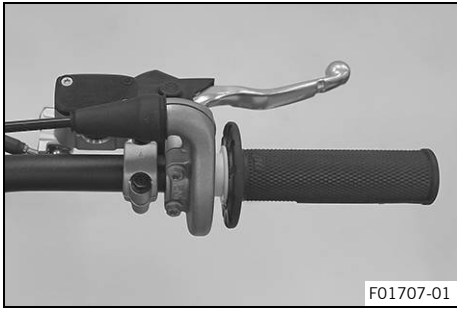

- Position the controls on the right half of the handlebar.

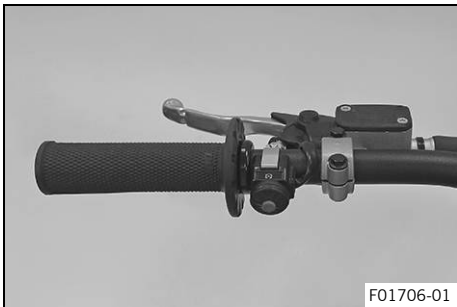

- Position the controls on the left handlebar half.
- Mount the cable ties.
- Mount the fuel tank breather.
- Install the front wheel. (📖 p. 14)
- Install front fender. (📖 p. 14)
- Install the start number plate. (📖 p. 15)



- Mount the handlebar cushion.



- Position the new footrest and pin.

**Info**

Only insert the pin to the extent that the spring can still be mounted.

---



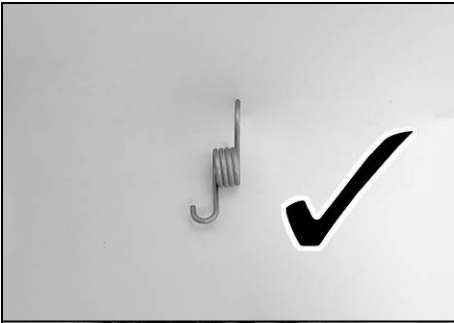

- Position spring as shown.
- ✓ Spring **A** engages in area **B**.

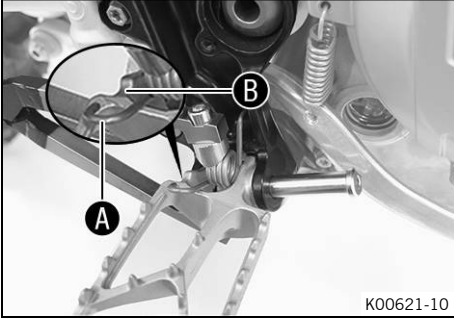

K00621-10

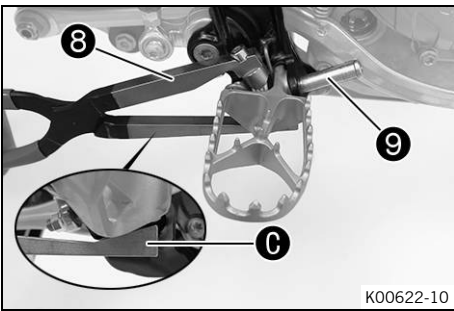

- Press the spring with special tool **8**.

Footrest spring plier (79029083000)

- ✓ The special tool is applied to area **C** on the footrest.
- Mount pin **9**.

K00622-10

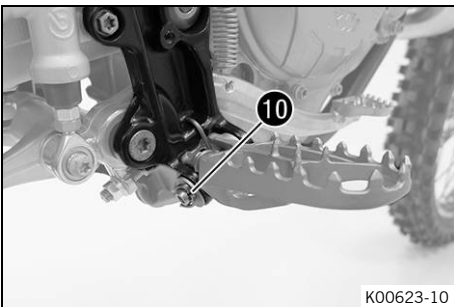

- Mount the washer and splint **10**.
- Repeat these steps on the opposite side.

K00623-10

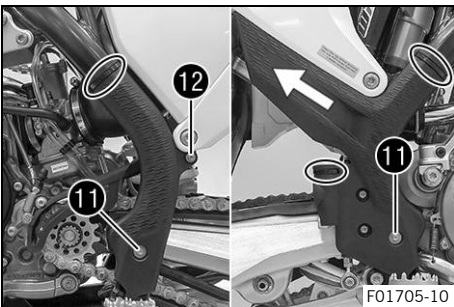

- Position the left frame protector.
- Insert the right frame protector from below and push it to the rear.
- Mount and tighten screws **11** with the washers.

Guideline

Screw, frame protector	M5	3 Nm (2.2 lbf ft)
------------------------	----	-------------------

- Mount and tighten screw **12**.

Guideline

Screw, frame protector	M5	3 Nm (2.2 lbf ft)
------------------------	----	-------------------

- Mount the cable ties.



- Attach the displacement stickers to the left and right of the side cover.
- Unpack and mount the **KTM PowerParts** included in the delivery (optional).



### Info

Read the accompanying **KTM PowerParts** fitting instructions.

- Attach the stickers included in the scope of supply (optional).
- (125 XC US)**

- Charge the 12-V battery. (📖 p. 12)

### Guideline

The 12-V battery must be fully charged before it is handed over to the customer.



### Info

The first charging process may take longer with a new 12-V battery.

- Refuel. (📖 p. 16)
- Position all controls in their exact positions on the handlebar. Tighten all screws.
- Remove the remaining film, padding, the corrugated cardboard, and the other packaging material.
- Prepare the vehicle according to the specifications in **KTM Dealer.net** for handover to the customer.

### 3.1 Raising the motorcycle with a lift stand

**Note**

**Material damage** The vehicle may be damaged by incorrect procedure when parking. Significant damage may be caused if the vehicle rolls away or falls over. The components for parking the vehicle are designed only for the weight of the vehicle.

- Park the vehicle on a firm and level surface.
- Ensure that nobody sits on the vehicle when the vehicle is parked on a stand.

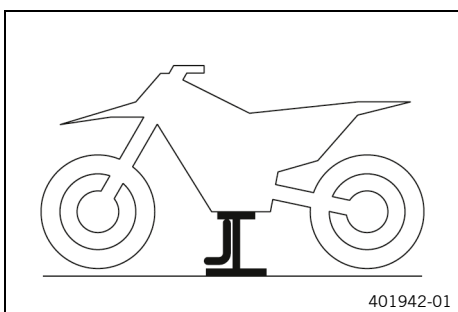

- Raise the motorcycle at the frame underneath the engine.

Lift stand (78129955100)

- ✓ Neither wheel is in contact with the ground.
- Secure the motorcycle against falling over.

### 3.2 Removing the motorcycle from the lift stand

**Note**

**Material damage** The vehicle may be damaged by incorrect procedure when parking. Significant damage may be caused if the vehicle rolls away or falls over. The components for parking the vehicle are designed only for the weight of the vehicle.

- Park the vehicle on a firm and level surface.
- Ensure that nobody sits on the vehicle when the vehicle is parked on a stand.

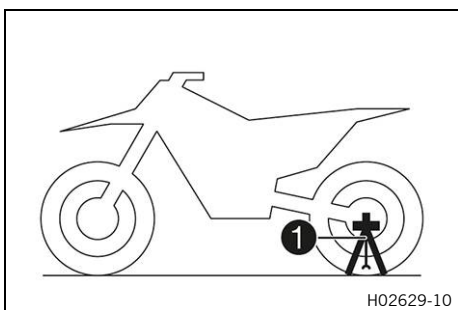

**(125/150 SX)**

- Remove the motorcycle from the lift stand.
- Remove the lift stand.
- To park the motorcycle, insert plug-in stand 1 into the left side of the wheel spindle.

**i Info**  
Remove the plug-in stand before riding.

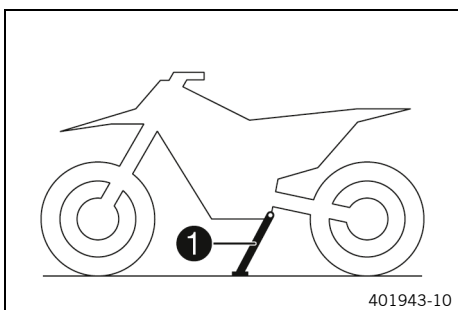

**(125 XC US)**

- Remove the motorcycle from the lift stand.
- Remove the lift stand.
- To park the motorcycle, press side stand 1 to the ground with your foot and lean the motorcycle on it.

**i Info**  
When you are riding, the side stand must be folded up and secured with the rubber strap.

## 3.3 Removing the 12-V battery (125 XC US)



### Warning

**Risk of injury** 12 V batteries contain harmful substances.

- Keep 12 V batteries out of the reach of children.
- Keep sparks and open flames away from 12 V batteries.
- Only charge 12 V batteries in well-ventilated rooms.
- Maintain a minimum clearance from inflammable materials when charging 12 V batteries.  
Minimum clearance 1 m (3 ft)
- Do not charge deeply discharged 12 V batteries if the charge is already below the minimum voltage.  
Minimum voltage before the start of the charge 9 V
- Dispose of 12 V batteries with less than the minimum voltage correctly.

### Preparatory work

- Remove the seat. (📖 p. 15)

### Main work

- Disconnect negative cable ① from the 12-V battery.
- Pull back positive terminal cover ② and disconnect the positive cable from the 12-V battery.
- Remove screw ③.
- Pull holding bracket ④ forward and remove the 12-V battery upwards.

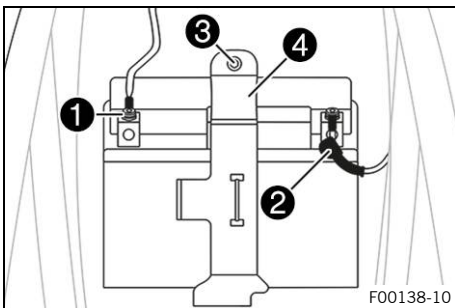

## 3.4 Installing the 12 V battery (125 XC US)

### Main work

- Position the 12 V battery in the battery compartment with the terminals facing forward, and secure with holding bracket ①.

12-V battery (HJTZ5S-FP-C)

- Mount and tighten screw ②.

#### Guideline

Remaining screws, chassis	M6	10 Nm (7.4 lbf ft)
---------------------------	----	--------------------

- Connect positive cable ③ to the 12 V battery.

#### Guideline

Screw, battery terminal	M5	2.5 Nm (1.84 lbf ft)
-------------------------	----	----------------------

Contact disks ① must be mounted under screws ⑤ and cable sockets ⑥ with the claws toward the battery terminal.

- Slide positive terminal cover ⑦ over the positive terminal.
- Connect negative cable ④ to the 12 V battery.

#### Guideline

Screw, battery terminal	M5	2.5 Nm (1.84 lbf ft)
-------------------------	----	----------------------

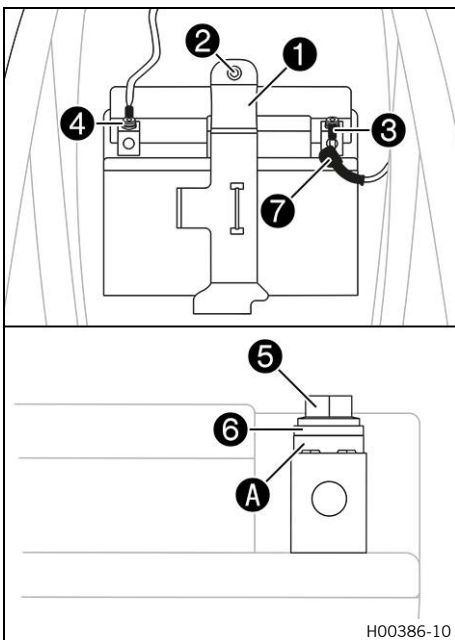

### Finishing work

- Mount the seat. (🔧 p. 15)



## 3.5 Disconnecting the negative cable of the 12-V battery (125 XC US)

### Preparatory work

- Remove the seat. (🔧 p. 15)

### Main work

- Disconnect negative cable ❶ of the 12-V battery.

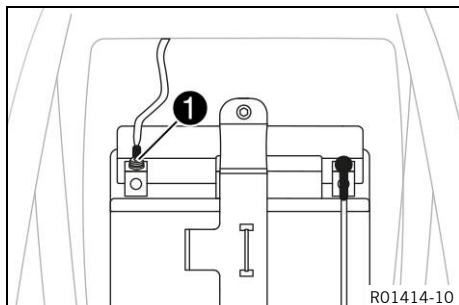

## 3.6 Connecting the negative cable of the 12 V battery (125 XC US)

### Main work

- Connect negative cable ❶ of the 12 V battery.

#### Guideline

Screw, battery terminal	M5	2.5 Nm (1.84 lbf ft)
-------------------------	----	-------------------------

Contact disks **A** must be mounted under the screw **2** and the cable lug **3** with the claws toward the battery terminal.

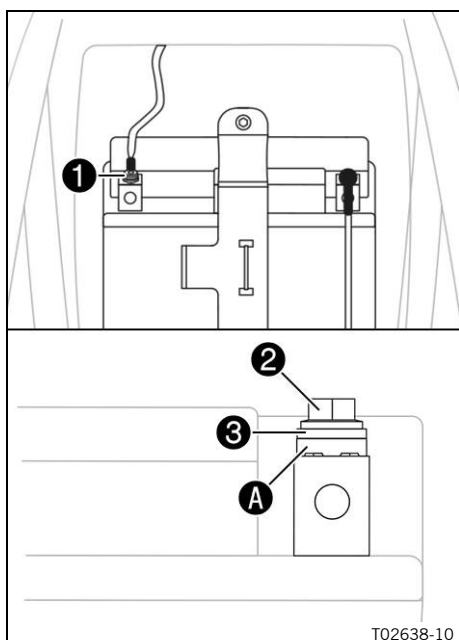

### Finishing work

- Mount the seat. (🔧 p. 15)



### 3.7 Charging the 12-V battery (125 XC US)



#### Warning

**Risk of injury** 12 V batteries contain harmful substances.

- Keep 12 V batteries out of the reach of children.
- Keep sparks and open flames away from 12 V batteries.
- Only charge 12 V batteries in well-ventilated rooms.
- Maintain a minimum clearance from inflammable materials when charging 12 V batteries.  
Minimum clearance 1 m (3 ft)
- Do not charge deeply discharged 12 V batteries if the charge is already below the minimum voltage.  
Minimum voltage before the start of the charge 9 V
- Dispose of 12 V batteries with less than the minimum voltage correctly.

#### Note

**Danger of damage** An incorrectly selected charging mode will damage the 12-V battery.

- Always select a charging mode that is compatible with the type of battery.



#### Note

**Environmental hazard** 12 V batteries contain environmentally hazardous materials.

- Do not dispose of 12 V batteries as household waste.
- Dispose of 12 V batteries at a collection point for used batteries.



#### Note

**Environmental hazard** Hazardous substances cause environmental damage.

- Dispose of oils, grease, filters, fuel, cleaning agents, brake fluid, etc., correctly and in compliance with the applicable regulations.



#### Info

Even when there is no load on the 12-V battery, it discharges steadily each day.

The charging level and the method of charging are very important for the service life of the 12-V battery.

Rapid recharging with a high charging current shortens the service life of the battery.

If the charging current, charging voltage, or charging time is exceeded, the 12-V battery will be destroyed.

If the 12-V battery is depleted by repeated starting, the 12-V battery must be charged immediately.

If the 12-V battery is left in a discharged state for an extended period, it will become deeply discharged and suffer a loss of capacity, destroying the battery.

The 12-V battery is maintenance-free.

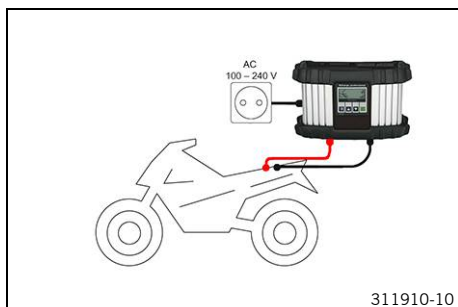

#### Preparatory work

- Remove the seat. (📖 p. 15)
- Disconnect the negative cable of the 12-V battery. (📖 p. 11)

#### Main work

- Connect a battery charger to the 12-V battery. Adjust the battery charger.

EU battery charger **XCharge-professional** (00029095050)

#### Alternative 1

US battery charger **XCharge-professional**  
(00029095051)

#### Alternative 2

UK battery charger **XCharge-professional**  
(00029095052)

**i Info**  
Follow the instructions of the charger and the manual.

- Disconnect the battery charger after charging the 12-V battery.  
Guideline

The charging current, charging voltage, and charging time must not be exceeded.	
Recharge the 12-V battery regularly when the motorcycle is not being used	3 months

**Finishing work**

- Connect the negative cable of the 12 V battery. (📖 p. 11)
- Mount the seat. (📖 p. 15)

## 3.8 Installing the fork legs

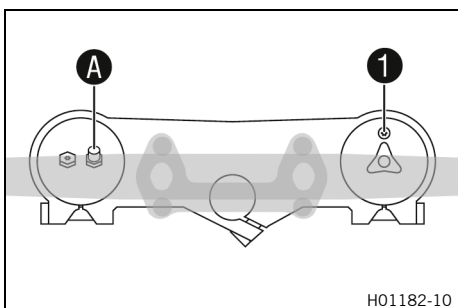

**Main work**

- Position the fork legs.
  - ✓ Air bleeder screw **1** of the right fork leg is positioned to the front.
  - ✓ Valve **A** of the left fork leg faces the front.

**i Info**  
Grooves are milled into the side of the upper end of the fork legs. The second milled groove (from the top) must be flush with the upper edge of the upper triple clamp. The air suspension is located in the left fork leg. The pressure and rebound damping is located in the right fork leg.

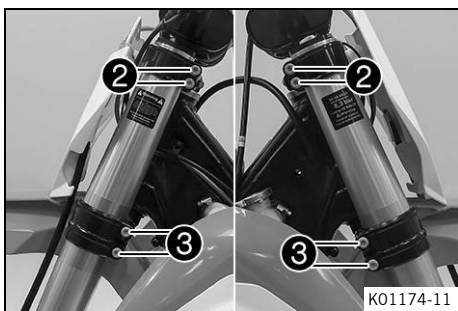

- Tighten screws **2**.

Guideline

Screw, top triple clamp	M8	17 Nm (12.5 lbf ft)
-------------------------	----	---------------------

- Tighten screws **3**.

Guideline

Screw, bottom triple clamp	M8	12 Nm (8.9 lbf ft)
----------------------------	----	--------------------

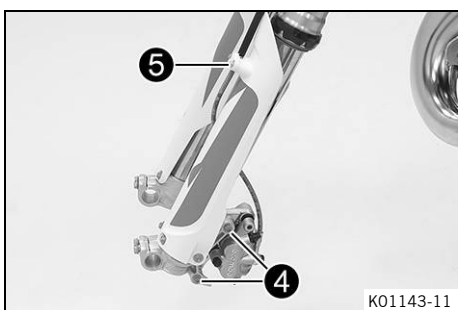

- Position the brake caliper. Mount and tighten screws **4**.

Guideline

Screw, front brake caliper	M8	25 Nm (18.4 lbf ft) <b>Loctite®243™</b>
----------------------------	----	--

- Position the brake line and the clamp. Mount and tighten screws **5**.

**Finishing work**

- Install the front wheel. (📖 p. 14)

## 3.9 Installing the front wheel



### Warning

**Danger of accidents** Oil or grease on the brake discs reduces the braking effect.

- Always keep the brake discs free of oil and grease.
- Clean the brake discs with brake cleaner when necessary.

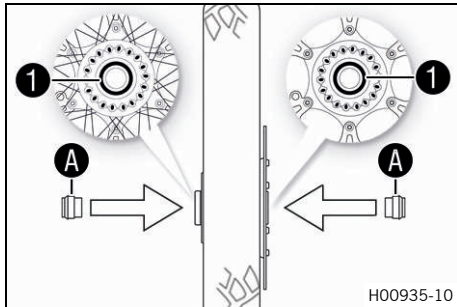

- Check the wheel bearing for damage and wear.
  - » If the wheel bearing is damaged or worn:
    - Change front wheel bearing.
- Clean and grease shaft seal rings ① and contact surfaces A of the spacers.

Long-life grease (📖 p. 22)

- Insert the spacers.
- Clean and grease the wheel spindle.

Long-life grease (📖 p. 22)

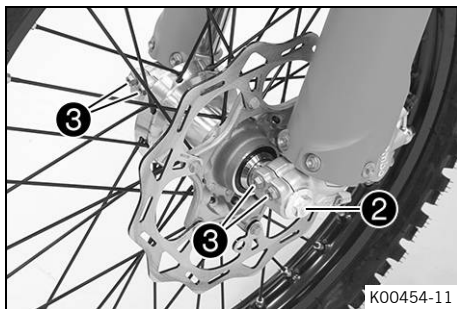

- Position the front wheel and insert the wheel spindle.
  - ✓ The brake linings are correctly positioned.
- Mount and tighten screw ②.

Guideline

Screw, front wheel spindle	M20x1.5	35 Nm (25.8 lbf ft)
----------------------------	---------	---------------------

- Operate the hand brake lever several times until the brake linings are seated correctly against the brake disc.
- Remove the motorcycle from the lift stand. (📖 p. 9)
- Operate the front brake and compress the fork a few times firmly.
  - ✓ The fork legs straighten.
- Tighten screws ③.

Guideline

Screw, fork stub	M8	15 Nm (11.1 lbf ft)
------------------	----	---------------------

## 3.10 Installing front fender

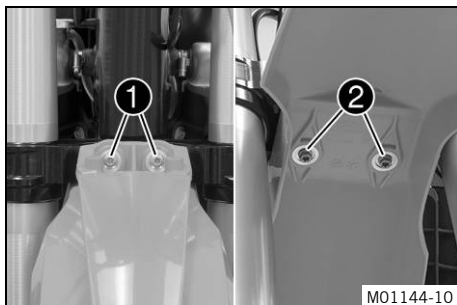

### Main work

- Position front fender. Mount and tighten screws ① and ②.

Guideline

Remaining screws, chassis	M6	10 Nm (7.4 lbf ft)
---------------------------	----	--------------------

### Finishing work

- Install the start number plate. (📖 p. 15)



**3.11 Installing the start number plate**

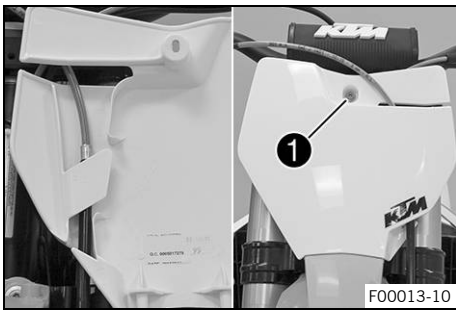

- Connect the brake line at the start number plate.
- Position the start number plate.
- ✓ The holding lugs engage in the fender.
- Mount and tighten screw ①.

**3.12 Removing the seat**

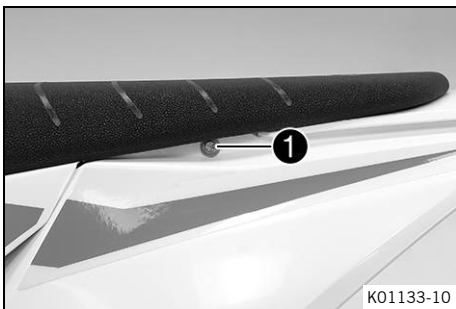

- Remove screw ①.

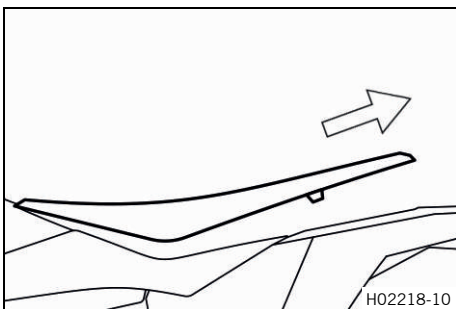

- Raise the rear of the seat, pull the seat back, and lift it off.

**3.13 Mounting the seat**

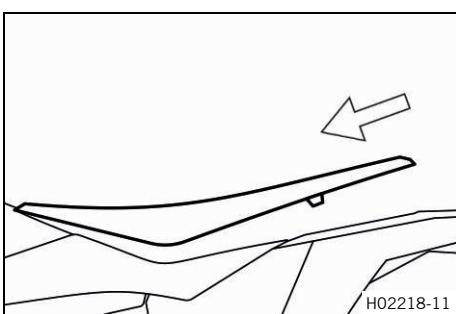

- Mount the front of the seat on the collar bushing of the fuel tank, lower the seat at the rear, and push the seat forward.
- Make sure that the seat is locked in correctly.

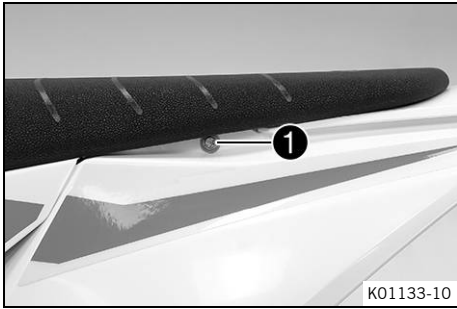

- Mount and tighten screw ❶.

Guideline

Remaining screws, chassis	M6	10 Nm (7.4 lbf ft)
---------------------------	----	--------------------

## 3.14 Refueling



### Danger

**Fire hazard** Fuel is highly flammable.

The fuel in the fuel tank expands when warm and can escape if overfilled.

- Do not fuel the vehicle in the vicinity of open flames or lit cigarettes.
- Switch off the engine for refueling.
- Make sure that no fuel is spilled; particularly not on hot parts of the vehicle.
- If any fuel is spilled, wipe it off immediately.
- Observe the specifications for refueling.



### Warning

**Danger of poisoning** Fuel is poisonous and a health hazard.

- Avoid skin, eye and clothing contact with fuel.
- Immediately consult a doctor if you swallow fuel.
- Do not inhale fuel vapors.
- In case of skin contact, rinse the affected area with plenty of water.
- Rinse the eyes thoroughly with water, and consult a doctor in case of fuel contact with the eyes.
- Change your clothing in case of fuel spills on them.



### Note

**Environmental hazard** Improper handling of fuel is a danger to the environment.

- Do not allow fuel to enter the groundwater, the soil, or the sewage system.

- Switch off the engine.
- Open the fuel tank filler cap. (📖 p. 17)
- Fill the fuel tank with fuel up to measurement ❶.

Guideline

Measurement of ❶	35 mm (1.38 in)
------------------	-----------------

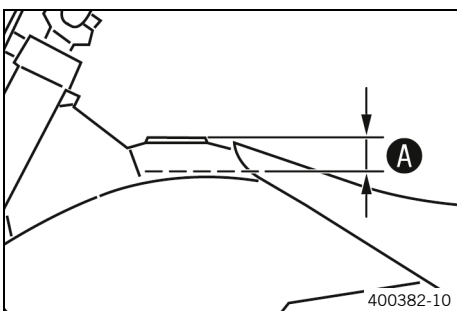

Total fuel tank capacity, approx. (125/150 SX)	7.5 l (1.98 US gal)	Super unleaded (98 octane) mixed with 2-stroke engine oil (1:40) (📖 p. 21)
Total fuel tank capacity, approx. (125 XC US)	10 l (2.6 US gal)	Super unleaded (98 octane) mixed with 2-stroke engine oil (1:40) (📖 p. 21)

Engine oil, 2-stroke (📖 p. 21)

- Close the fuel tank filler cap. (📖 p. 18)



### 3.15 Opening the fuel tank filler cap



**Danger**

**Fire hazard** Fuel is highly flammable.

The fuel in the fuel tank expands when warm and can escape if overfilled.

- Do not fuel the vehicle in the vicinity of open flames or lit cigarettes.
- Switch off the engine for refueling.
- Make sure that no fuel is spilled; particularly not on hot parts of the vehicle.
- If any fuel is spilled, wipe it off immediately.
- Observe the specifications for refueling.



**Warning**

**Danger of poisoning** Fuel is poisonous and a health hazard.

- Avoid skin, eye and clothing contact with fuel.
- Immediately consult a doctor if you swallow fuel.
- Do not inhale fuel vapors.
- In case of skin contact, rinse the affected area with plenty of water.
- Rinse the eyes thoroughly with water, and consult a doctor in case of fuel contact with the eyes.
- Change your clothing in case of fuel spills on them.
- Keep fuels correctly in a suitable canister, and out of the reach of children.



**Note**

**Environmental hazard** Improper handling of fuel is a danger to the environment.

- Do not allow fuel to enter the groundwater, the soil, or the sewage system.

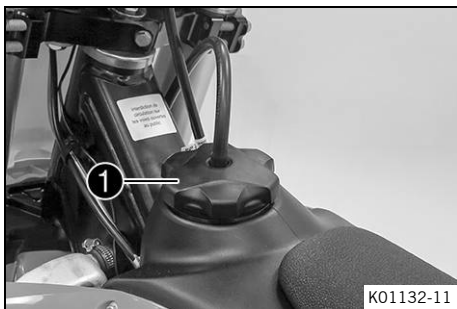

(125/150 SX)

- Turn fuel tank filler cap ❶ counterclockwise and lift it off.

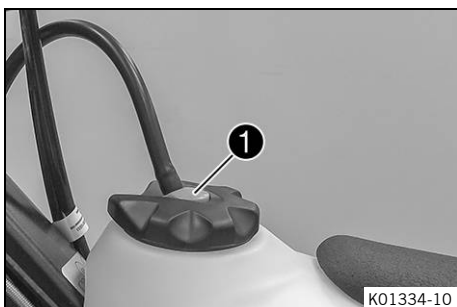

(125 XC US)

- Press release button ❶, turn the fuel tank filler cap counterclockwise, and lift it off.



## 3.16 Closing the fuel tank filler cap

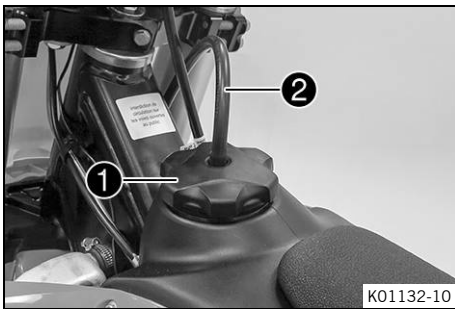

(125/150 SX)

- Mount fuel tank filler cap ① and turn it clockwise until the fuel tank is tightly closed.



### Info

Route fuel tank breather hose ② without kinks.

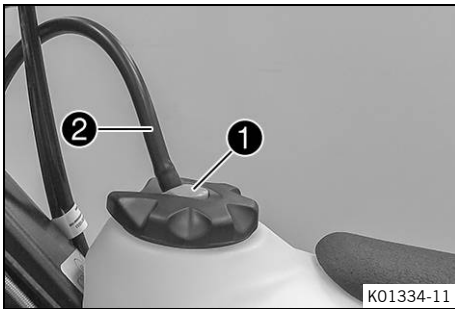

(125 XC US)

- Mount filler cap ① and turn it clockwise until the release button engages.



### Info

Route fuel tank breather hose ② without kinks.

**4.1 Chassis tightening torques**

Screw, stop button	M3	0.4 Nm (0.3 lbf ft)
Screw, fixed grip	M4	5 Nm (3.7 lbf ft) <b>Loctite®243™</b>
Screw, service hour counter	M4	0.8 Nm (0.59 lbf ft)
Spoke nipple, front wheel	M4.5	6 Nm (4.4 lbf ft)
Spoke nipple, rear wheel	M4.5	6 Nm (4.4 lbf ft)
Remaining nuts, chassis	M5	5 Nm (3.7 lbf ft)
Remaining screws, chassis	M5	5 Nm (3.7 lbf ft)
Screw, shock absorber adjusting ring	M5	5 Nm (3.7 lbf ft)
Screws on main silencer	M5	7 Nm (5.2 lbf ft)
Remaining nuts, chassis	M6	10 Nm (7.4 lbf ft)
Remaining screws, chassis	M6	10 Nm (7.4 lbf ft)
Screw, absorbing element on frame	M6	6 Nm (4.4 lbf ft)
Screw, absorbing element on manifold	M6	6 Nm (4.4 lbf ft)
Screw, ball joint of push rod on foot brake cylinder	M6	10 Nm (7.4 lbf ft) <b>Loctite®243™</b>
Screw, chain sliding guard	M6	10 Nm (7.4 lbf ft) <b>Loctite®243™</b>
Screw, front brake disc	M6	14 Nm (10.3 lbf ft) <b>Loctite®243™</b>
Screw, rear brake disc	M6	14 Nm (10.3 lbf ft) <b>Loctite®243™</b>
Screw, throttle grip	M6	5 Nm (3.7 lbf ft)
Nut, foot brake lever stop	M8	20 Nm (14.8 lbf ft)
Nut, rear sprocket screw	M8	35 Nm (25.8 lbf ft) <b>Loctite®2701™</b>
Nut, rim lock	M8	12 Nm (8.9 lbf ft)
Remaining nuts, chassis	M8	25 Nm (18.4 lbf ft)
Remaining screws, chassis	M8	25 Nm (18.4 lbf ft)
Screw, bottom triple clamp	M8	12 Nm (8.9 lbf ft)
Screw, chain sliding piece	M8	15 Nm (11.1 lbf ft)
Screw, engine brace on engine	M8x20	25 Nm (18.4 lbf ft) <b>Loctite®243™</b>
Screw, engine brace on frame	M8x15	25 Nm (18.4 lbf ft) <b>Loctite®2701™</b>
Screw, fork stub	M8	15 Nm (11.1 lbf ft)
Screw, front brake caliper	M8	25 Nm (18.4 lbf ft) <b>Loctite®243™</b>
Screw, handlebar clamp	M8	20 Nm (14.8 lbf ft)
Screw, manifold	M8	15 Nm (11.1 lbf ft)
Screw, subframe bottom	M8x18	30 Nm (22.1 lbf ft) <b>Loctite®2701™</b>
Screw, subframe top	M8x20	35 Nm (25.8 lbf ft) <b>Loctite®2701™</b>

## 4 TECHNICAL DATA

Screw, top steering stem	M8	20 Nm (14.8 lbf ft) <b>Loctite®243™</b>
Screw, top triple clamp	M8	17 Nm (12.5 lbf ft)
Engine bracket screw	M10	60 Nm (44.3 lbf ft)
Remaining nuts, chassis	M10	45 Nm (33.2 lbf ft)
Remaining screws, chassis	M10	45 Nm (33.2 lbf ft)
Screw, bottom shock absorber	M10	60 Nm (44.3 lbf ft) <b>Loctite®2701™</b>
Screw, handlebar support	M10	40 Nm (29.5 lbf ft) <b>Loctite®243™</b>
Screw, top shock absorber	M10	60 Nm (44.3 lbf ft) <b>Loctite®2701™</b>
Nut, angle lever to link fork	M14x1.5	60 Nm (44.3 lbf ft)
Nut, frame on linkage lever	M14x1.5	60 Nm (44.3 lbf ft)
Nut, linkage lever on angle lever	M14x1.5	60 Nm (44.3 lbf ft)
Nut, fork pivot	M16x1.5	100 Nm (73.8 lbf ft)
Screw, front wheel spindle	M20x1.5	35 Nm (25.8 lbf ft)
Screw, top steering head	M20x1.5	12 Nm (8.9 lbf ft)
Screw-in fitting, cooling system	M24x1.5	18 Nm (13.3 lbf ft) <b>Loctite®243™</b>
Nut, rear wheel spindle	M25x1.5	80 Nm (59 lbf ft)

**Engine oil, 2-stroke**

**Standard/classification**

- JASO FD (📖 p. 23)

**Guideline**

- Only use high-grade 2-stroke engine oil from a reputable brand.

fully synthetic
-----------------

**Recommended supplier**

**MOTOREX®**

- Cross Power 2T

**Super unleaded (ROZ 98 / RON 98 / PON 94)**

**Standard/classification**

- DIN EN 228 (ROZ 98 / RON 98 / PON 94)

**Super unleaded (98 octane) mixed with 2-stroke engine oil (1:40)**

**Standard/classification**

- DIN EN 228
- JASO FD (📖 p. 23) (1:40)

**Mixture ratio**

1:40	Engine oil, 2-stroke (📖 p. 21) Super unleaded (ROZ 98 / RON 98 / PON 94) (📖 p. 21)
------	---

**Recommended supplier**

**MOTOREX®**

- Cross Power 2T

### Long-life grease

Recommended supplier

MOTOREX®

– Bike Grease 2000



**JASO FD**

JASO FD is a classification for a 2-stroke engine oil that was specifically developed for the extreme demands of racing. Thanks to first-rate synthetic esters and specially designed additives, superb combustion is achieved even under extreme operating conditions.



3214496en

05/2021

