

**350 EXC-F  
350 XCF-W  
350 EXC-F SIX DAYS  
350 EXC-F FACTORY EDITION**

ART. NO. 3214519EN





Perform the work described in these setup instructions before the vehicle is delivered to the customer.

Read the setup instructions in their entirety before beginning work.

These setup instructions were written to correspond to the latest state of this series. We reserve the right to make changes in the interest of technical advancement without at the same time updating this manual. We shall not provide a description of general workshop methods. Likewise, safety rules that apply in a workshop are not specified here. It is assumed that the work will be performed by a fully trained mechanic.

All specifications contained herein are non-binding. KTM Sportmotorcycle GmbH specifically reserves the right to modify or delete technical specifications, prices, colors, forms, materials, services, designs, equipment, etc., without prior notice and without specifying reasons, to adapt these to local conditions, as well as to stop production of a particular model without prior notice. KTM accepts no liability for delivery options, deviations from figures and descriptions, misprints, and other errors. The models portrayed partly contain special equipment that does not belong to the regular scope of supply.

© 2021 KTM Sportmotorcycle GmbH, Mattighofen Austria

All rights reserved

Reproduction, even in part, as well as copying of all kinds, is permitted only with the express written permission of the copyright owner.



ISO 9001(12 100 6061)

KTM applies quality assurance processes that lead to the highest possible product quality as defined in the ISO 9001 international quality management standard.

Issued by: TÜV Management Service

REG.NO. 12 100 6061

KTM Sportmotorcycle GmbH  
Stallhofnerstraße 3  
5230 Mattighofen, Austria

This document is valid for the following models:

350 EXC-F EU (F8203V9)

350 EXC-F BR (F8240V9)

350 EXC-F AR (F8242V9)

350 EXC-F US (F8275V9)

350 XCF-W US (F8275V1)

350 EXC-F SIX DAYS EU (F8203V2)

350 EXC-F SIX DAYS BR (F8240V2)

350 EXC-F SIX DAYS CN (F8287V2)

350 EXC-F SIX DAYS ASEAN (F8288V2)

350 EXC-F FACTORY EDITION EU (F8203V3)



3214519en

09/2021

# 1 MEANS OF REPRESENTATION

## 1.1 Symbols used

The meaning of specific symbols is described below.



Indicates an expected reaction (e.g. of a work step or a function).



Indicates an unexpected reaction (e.g. of a work step or a function).



Indicates a page reference (more information is provided on the specified page).



Indicates information with more details or tips.



Indicates the result of a testing step.



Indicates a voltage measurement.



Indicates a current measurement.



Indicates a resistance measurement.



Indicates the end of an activity including potential rework.

## 1.2 Formats used

The typographical formats used in this document are explained below.

**Proprietary name**

Indicates a proprietary name.

**Name®**

Indicates a protected name.

**Brand™**

Indicates a brand available on the open market.

**Underlined terms**

Refer to technical details of the vehicle or indicate technical terms, which are explained in the glossary.

## 2.1 Transport mode

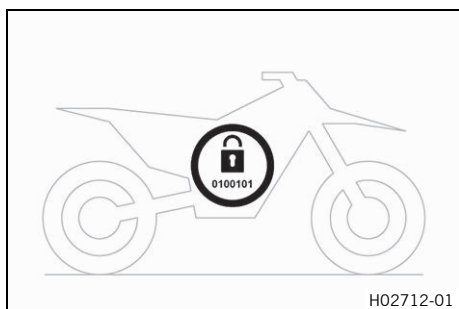

This vehicle was blocked for transport in the software. To operate the vehicle, the vehicle electronics must be enabled. This process is conducted during initial setup in KTM Dealer.net. Enabling ensures that the initial setup in KTM Dealer.net is documented.

Enabling can be performed either temporarily, e.g. for a test ride, or permanently for vehicle handover.



### Info

Make sure that the vehicle is permanently enabled before handing it over to the customer.

## 2.2 Diagnostics connector

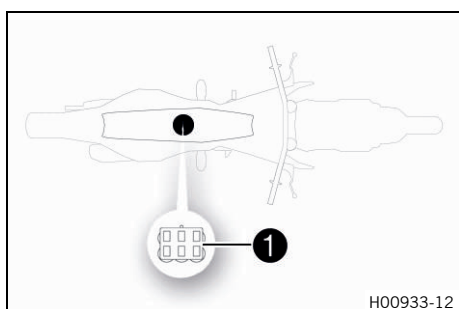

Diagnostics connector ① is located under the seat.

## 2.3 Unpacking and setting up the vehicle

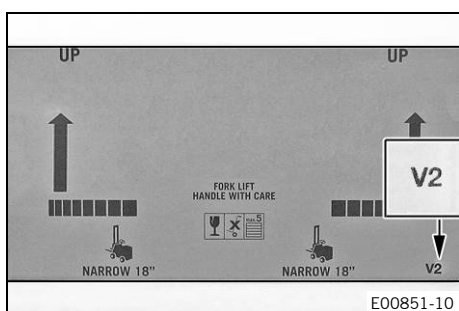

### Condition

#### Packaging V2

- Remove the box and the plastic packaging.



### Info

To avoid damaging the motorcycle during the setup, leave the protective film on the vehicle until you have finished.

- Remove the separate enclosure and unpack it. Check that the scope of supply is complete using the enclosed packing list.



### Info

The procedure for missing components is described in the Customer Service Manual.

- Have a lift stand available.

Lift stand (78129955100)

- Carefully loosen and remove the tension belt of the footrest mount.



### Info

An assistant prevents the motorcycle from falling over.

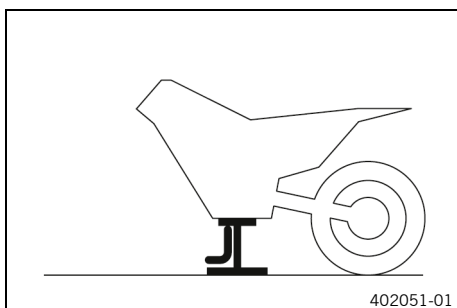
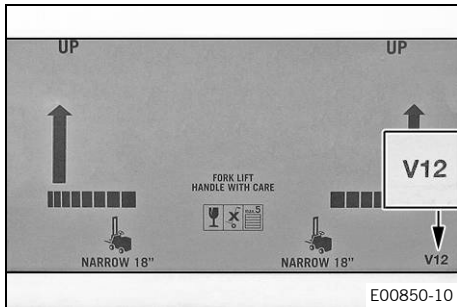
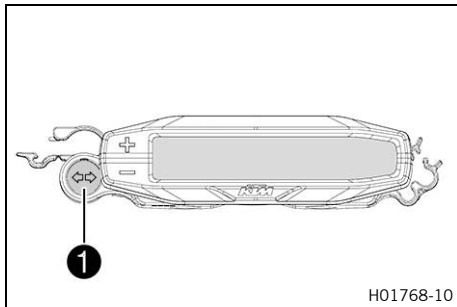
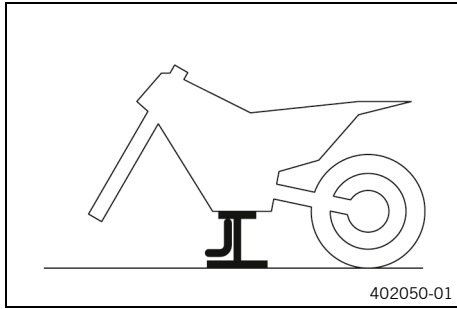

- Together with an assistant, take the vehicle off the pallet.
- Position the vehicle on a lift stand.
- Check the vehicle for transport damage.

---

**i Info**  
The procedure in the event of transport damage is described in the Customer Service Manual.

---

- Position the turn signal indicator lamp **1** in the combination instrument bracket.
- Remove the headlight mask with the headlight. (📖 p. 20)

### Condition

#### Packaging V12

- Remove the box and the plastic packaging.

---

**i Info**  
An assistant prevents the motorcycle from falling over.  
To avoid damaging the motorcycle during the setup, leave the protective film on the vehicle until you have finished.

---

- Remove and unpack the separate enclosure and components. Check that the scope of supply is complete using the enclosed packing list.

---

**i Info**  
The procedure for missing components is described in the Customer Service Manual.

---

- Remove the two cable ties on the triple clamp.
- Have a lift stand available.

Lift stand (78129955100)

- Together with an assistant, take the vehicle off the pallet.
- Position the vehicle on a lift stand.
- Check the vehicle and components for transport damage.

---

**i Info**  
The procedure in the event of transport damage is described in the Customer Service Manual.

---

- Install the shock absorber. (📖 p. 23)

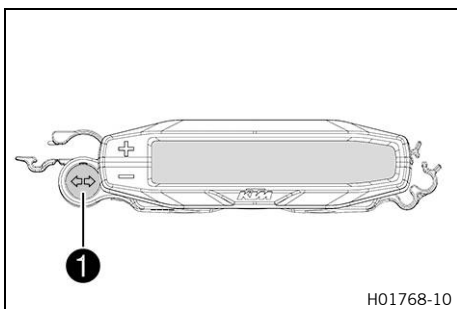

- Position turn signal indicator lamp **1** in the combination instrument bracket.

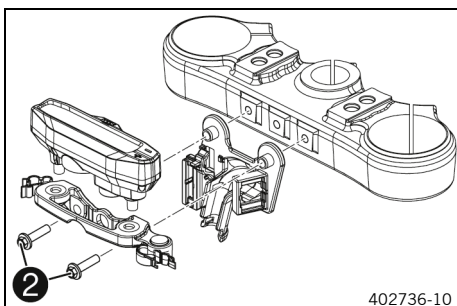

- Position the connector board and combination instrument on the upper triple clamp.
- Mount and tighten screws **2**.

Guideline

Remaining screws, chassis	M6	10 Nm (7.4 lbf ft)
---------------------------	----	--------------------

- Route the clutch line with the clutch master cylinder toward the front between the upper and lower triple clamps.
- Install the fork legs. (📖 p. 23)

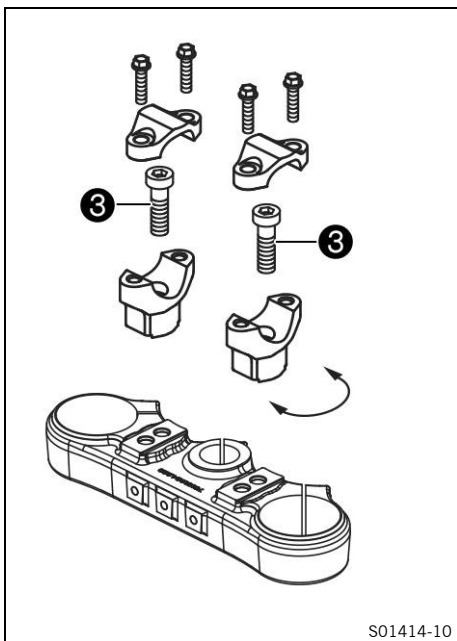

**(All standard models)**

- Remove screws **3** and take off the handlebar supports.
- Move the handlebar supports to the desired position and mount and tighten screws **3**.

Guideline

Screw, handlebar holder	M10	40 Nm (29.5 lbf ft) <b>Loctite®243™</b>
-------------------------	-----	--



**Info**

Position the left and right handlebar supports evenly.



**Warning**

**Danger of accidents** A repaired handlebar poses a safety risk.

If the handlebar is bent or straightened, the material becomes fatigued. The handlebar may break as a result.

- Change the handlebar if the handlebar is damaged or bent.

- Position the handlebar.



**Info**

Make sure the cables and wiring are positioned correctly.

- Position the handlebar clamps. Mount and tighten the screws evenly.

Guideline

Screw, handlebar clamp	M8	20 Nm (14.8 lbf ft)
------------------------	----	---------------------



**Info**

The markings on the handlebar should be at the center of the handlebar clamps. Keep the installed gap widths equal when tightening.

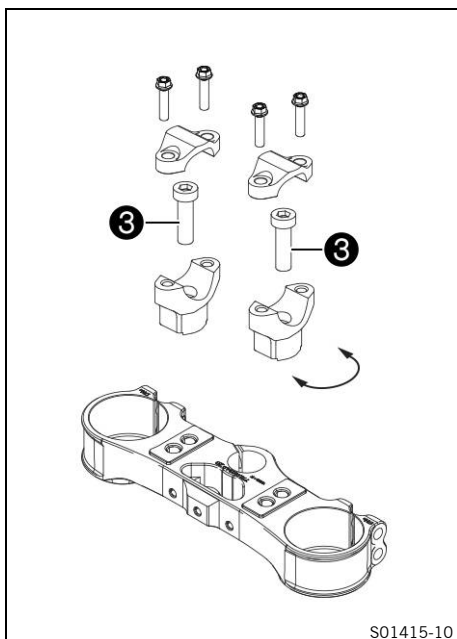

**(All special models)**

- Remove screws ③ and take off the handlebar supports.
- Move the handlebar supports to the desired position and mount and tighten screws ③.

Guideline

Screw, handlebar holder	M10	40 Nm (29.5 lbf ft) <b>Loctite®243™</b>
-------------------------	-----	--



**Info**

Position the left and right handlebar supports evenly.



**Warning**

**Danger of accidents** A repaired handlebar poses a safety risk.

If the handlebar is bent or straightened, the material becomes fatigued. The handlebar may break as a result.

- Change the handlebar if the handlebar is damaged or bent.

- Position the handlebar.



**Info**

Make sure the cables and wiring are positioned correctly.



- Position the handlebar clamps. Mount and tighten the screws evenly.

Guideline

Screw, handlebar clamp	M8	20 Nm (14.8 lbf ft)
------------------------	----	------------------------

**i Info**

The markings on the handlebar should be at the center of the handlebar clamps. Keep the installed gap widths equal when tightening.



S03665-01

**(All EU/AR/ASEAN/BR/CN models)**

- Position the controls on the right half of the handlebar.

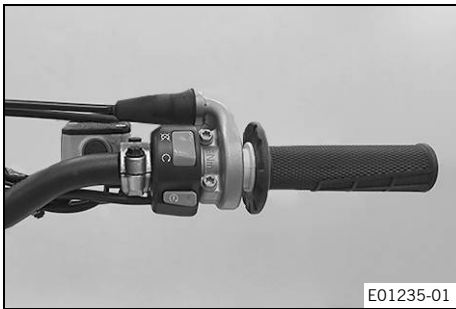

E01235-01

**(EXC-F US)**

- Position the controls on the right half of the handlebar.



S03667-01

**(XCF-W)**

- Position the controls on the right half of the handlebar.



S01423-01

**(All EU/AR/ASEAN/BR/CN models)**

- Position the controls on the left handlebar half.



### (EXC-F US)

- Position the controls on the left handlebar half.



### (XCF-W)

- Position the controls on the left handlebar half.



### (All special models, XCF-W)



#### Warning

**Voiding of the government approval for road use and the insurance coverage** If the combination switch is mounted, the vehicle's road permit, if any, expires.

- Only operate the vehicle in closed-off areas remote from public road traffic if the combination switch is installed.

- (Optional) Mount combination switch on the left side.



#### Info

The figure shows a possible installation position of the left side combination switch.

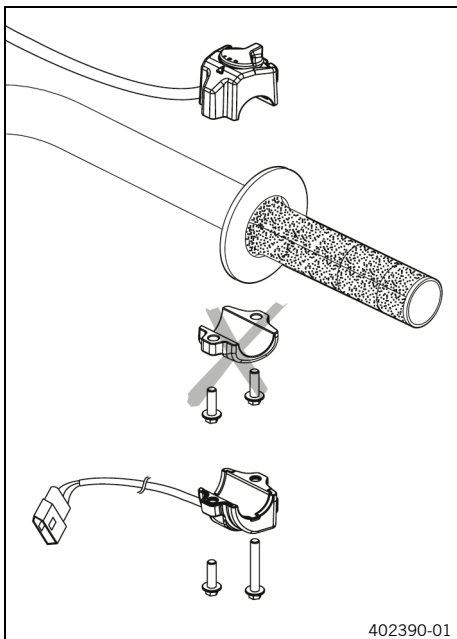

**(All EU/AR/ASEAN/BR/CN models)**

- Mount the turn signal switch.



**Condition**

Packaging **V12**

**(All EU/AR/ASEAN/BR/CN models, EXC-F US)**

- Join all plug-in connectors to the connector board.
- Route the cables without tension and secure with the cable ties.

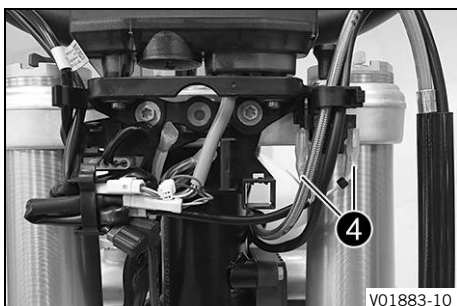

**(XCF-W)**

- Plug in light switch ④ with the yellow and white cables.
- Join all plug-in connectors to the connector board.
- Route the cables without tension and secure with the cable ties.

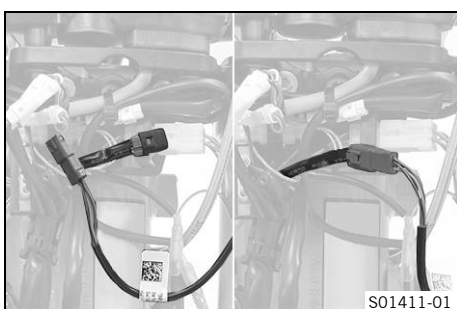

**(All special models, XCF-W)**



**Warning**

**Voiding of the government approval for road use and the insurance coverage** If the combination switch is mounted, the vehicle's road permit, if any, expires.

- Only operate the vehicle in closed-off areas remote from public road traffic if the combination switch is installed.

- (Optional) Remove the protection cap and join the plug-in connector of the left combination switch.

## 2 SETUP

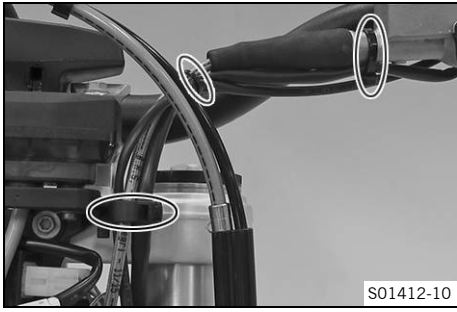

- Route the cable without tension and secure with cable ties and cable holders.

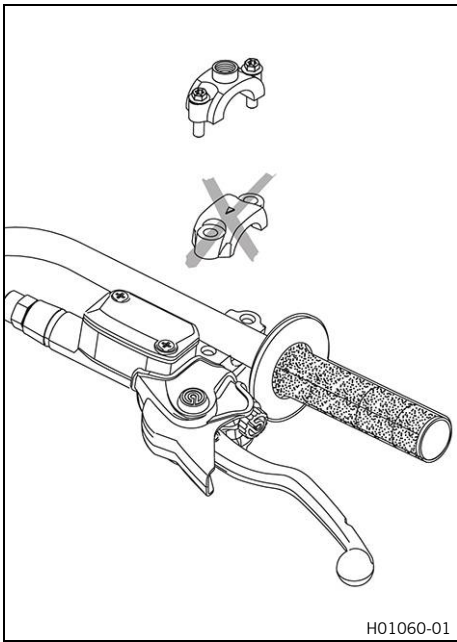

- Mount the mirror clamps on both sides.

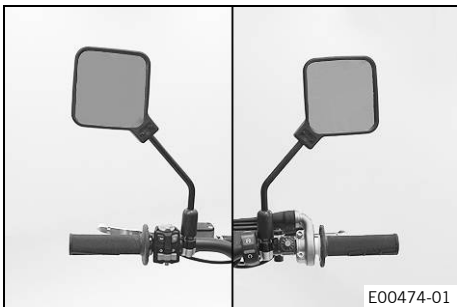

- Mount both rear mirrors with the adapter.



- Preassemble the hand guards on the left and right.



- Mount the left hand guard.
- Mount the right hand guard.

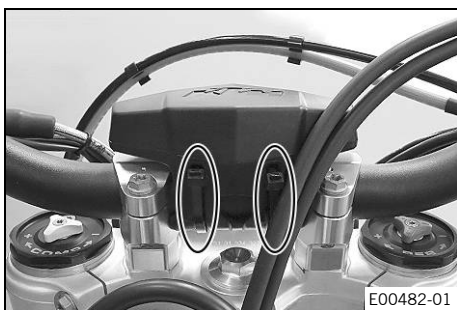

- Secure the handlebar cushion with two cable ties.
- Install front fender. (📖 p. 25)
- Install the front wheel. (📖 p. 24)

**(All EU/US/ASEAN/CN models)**

- Remove the 12-V battery. (📖 p. 27)
- Charge the 12-V battery. (📖 p. 31)

Guideline

The 12-V battery must be fully charged before it is handed over to the customer.

**Info**

The first charging process may take longer with a new 12-V battery.

---

**(EXC-F AR/BR, EXC-F SIX DAYS BR)****Warning**

**Risk of injury** Battery acid and battery gases cause serious chemical burns.

- Keep 12 V batteries out of the reach of children.
  - Wear suitable protective clothing and safety glasses.
  - Avoid contact with battery acid and battery gases.
  - Keep sparks or open flames away from the 12 V battery.
  - Only charge 12 V batteries in well-ventilated rooms.
  - Rinse the affected area immediately with plenty of water in the event of contact with the skin.
  - Rinse eyes with water for at least 15 minutes and consult a doctor immediately if battery acid and battery gases get into the eyes.
- 

- Fill the 12 V battery.
- 

**Info**

Read the notes in the 12 V battery accessory pack.

---

- Charge the 12-V battery. (📖 p. 33)

**Guideline**

The 12-V battery must be fully charged before it is handed over to the customer.
--

---

**Info**

The first charging process may take longer with a new 12-V battery.

---

**(XCF-W, EXC-F US)**

- Install the headlight mask with the headlight. (📖 p. 21)
  - Install the 12-V battery. (📖 p. 29)
-

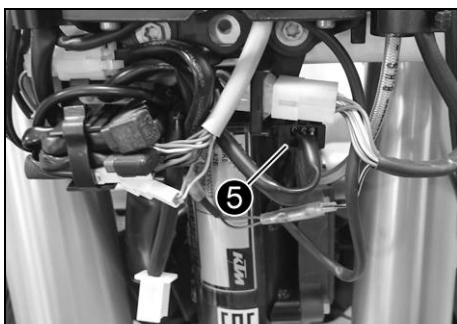

**(All EU/AR/ASEAN/BR/CN models)**

- Remove connector **5** from the bracket and join with turn signal wiring harness.

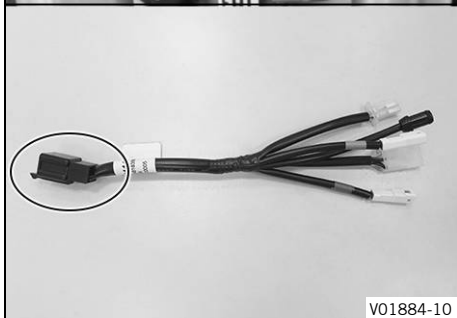

V01884-10

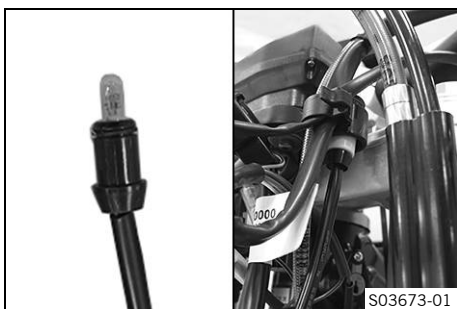

S03673-01

- Insert the black and violet cables of the bulb included in the separate enclosure into the socket and position it in the turn signal indicator lamp.

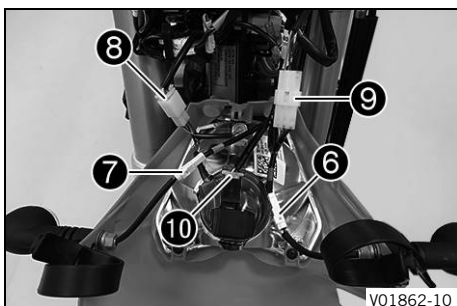

V01862-10

- Position the turn signal on the headlight mask on both sides, mount nuts with washers and tighten.
- Join plug-in connector **6** of the left turn signal using the violet and brown cable colors of the turn signal cable harness.

**i Info**

Pay attention to where the brake line is routed when doing so.

- Join plug-in connector **7** of the right turn signal using the black and brown cable colors of the turn signal cable harness.
- Join plug-in connector **8** of the headlight.
- Connect plug-in connector **9** of the turn signal switch.
- Secure turn signal relay **10** with a cable tie and plug in the connector.
- Install the headlight mask with the headlight. (📖 p. 21)
- Remove the air filter box cover. (📖 p. 34)
- Remove the rear left side cover. (📖 p. 35)

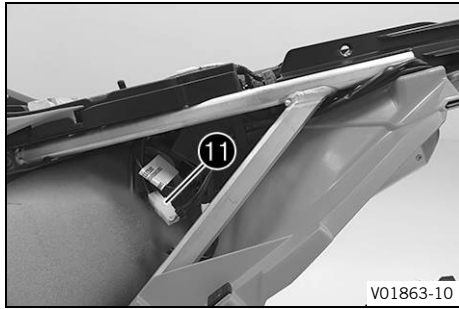

- Disconnect tail light plug-in connector **11** on the wiring harness.



- Remove screws **12**.
- Remove screws **13**.
- Remove the license plate holder with the tail light.



### Info

Pay attention to the cable of the tail light.

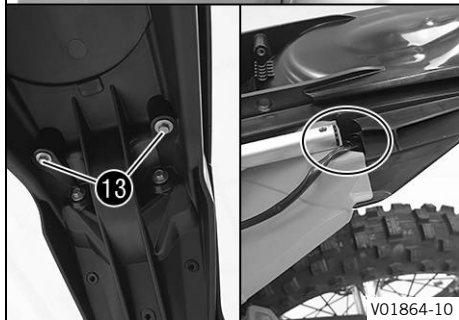

- Feed the cable between the fairing parts.



- Remove screws **14** on the license plate holder and hang the tail light to the side.





V01866-10

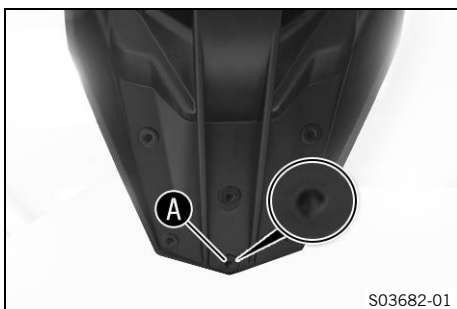

S03682-01



S03683-10

- Position the turn signal on both sides on the license plate holder, mount nuts with washers and tighten.
- Position the license plate lamp on the license plate holder, and mount and tighten screws 15.
- Mount reflector 16 on license plate holder.

- Drill a hole at marking A on the license plate holder to the size of the marking.

- Position the tail light together with the license plate holder on the license plate bracket.



**Info**

Ensure that the cables are routed correctly.



- Mount and tighten screws 14.

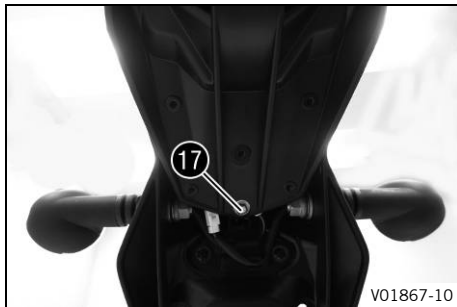

- Mount and tighten screw 17.

Guideline

Remaining screws, chassis	<b>EJOT PT®</b> K60x25-Z	2 Nm (1.5 lbf ft)
---------------------------	-----------------------------	-------------------

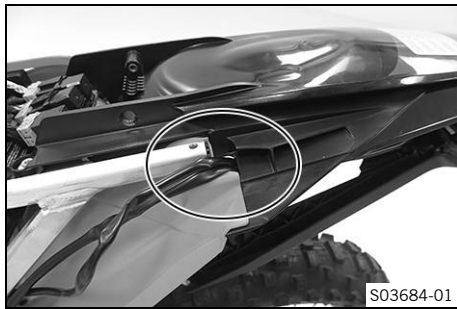

- Feed the wiring harnesses through the opening.
- Position the license plate holder on the rear.



- Mount and tighten screws 12 with the collar bushing.

Guideline

Remaining screws, chassis	M6	10 Nm (7.4 lbf ft)
---------------------------	----	--------------------

- Mount and tighten screws 13.

Guideline

Remaining screws, chassis	<b>EJOT PT®</b> K60x25-Z	2 Nm (1.5 lbf ft)
---------------------------	-----------------------------	-------------------

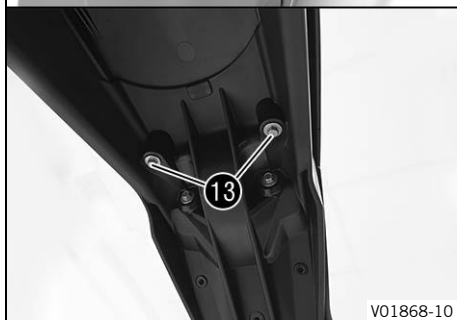

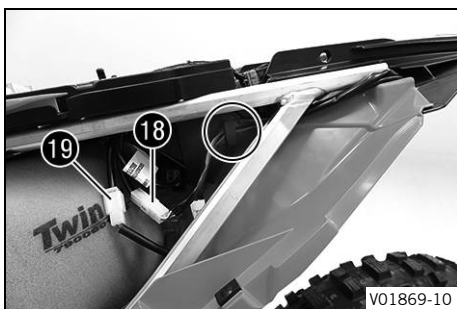

- Join the plug-in connectors of tail light 18 and turn signal cable harness 19 with the wiring harness.

**i Info**  
Pay attention to routing of the wiring harnesses.

- Install the rear left side cover. (📖 p. 36)
- Install the air filter box cover. (📖 p. 35)
- Install the 12-V battery. (📖 p. 29)



- Position the right footrest and pin.

**i Info**  
Only insert the pin to the extent that the spring can still be mounted.

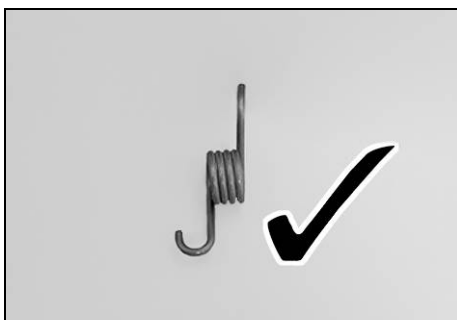

- Position spring as shown.
- ✓ Spring B engages in area C.

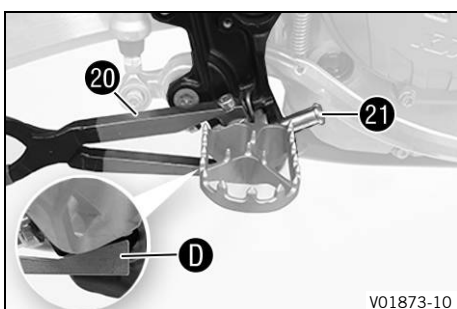
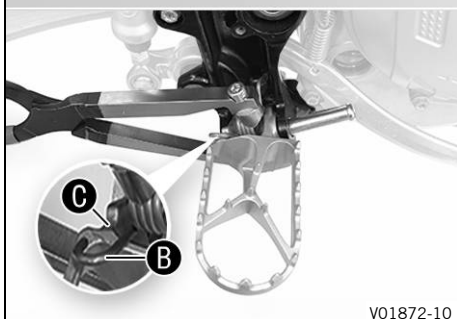

- Press the spring with special tool 20.

Footrest spring plier (79029083000)

- ✓ The special tool is applied to area D on the footrest.
- Mount pin 21.

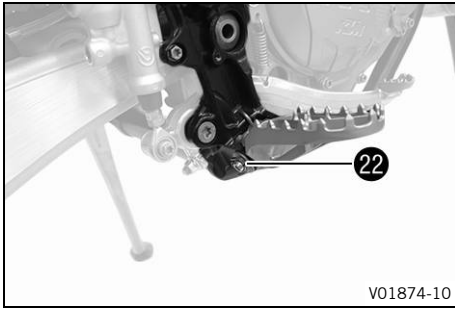

- Mount the washer and splint 22.

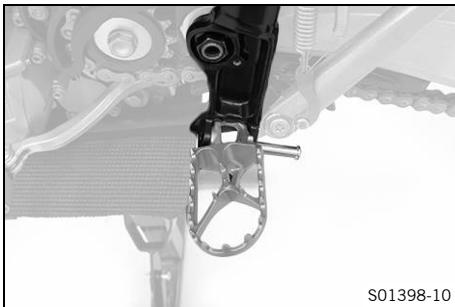

- Position the left footrest and pin.



**Info**

Only insert the pin to the extent that the spring can still be mounted.

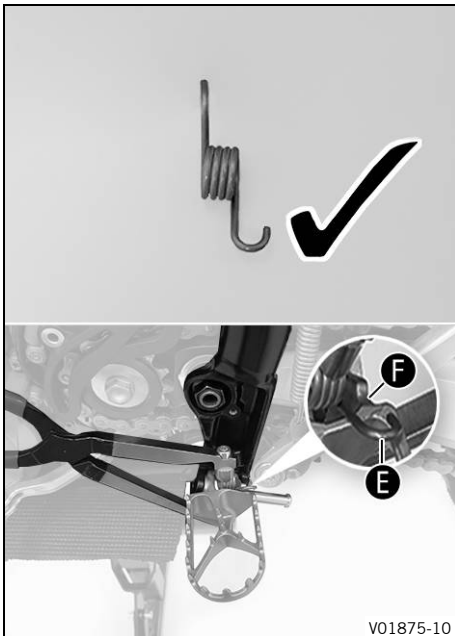

- Position spring as shown.
- ✓ Spring E engages in area F.

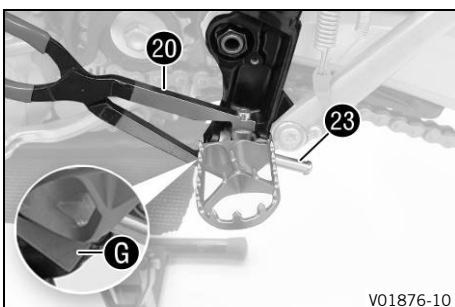

- Press the spring with special tool 20.

Footrest spring plier (79029083000)

- ✓ The special tool is applied to area G on the footrest.
- Mount pin 23.

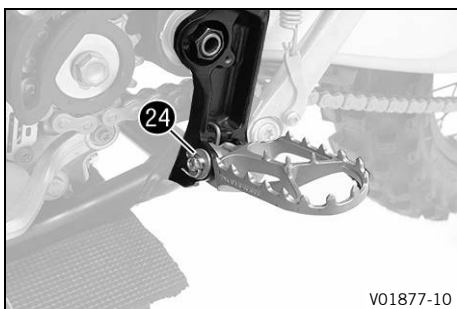

- Mount the washer and splint 24.

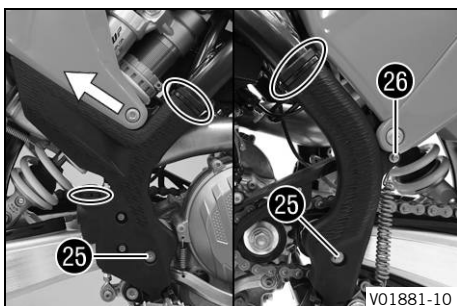

- Position the frame protectors on both sides.
- Mount and tighten screws 25.

Guideline

Screw, frame protector	M5	3 Nm (2.2 lbf ft)
------------------------	----	-------------------

- Mount and tighten screw 26 with washers.

Guideline

Screw, frame protector	M5	3 Nm (2.2 lbf ft)
------------------------	----	-------------------

- Mount the cable ties.

**(All special models, XCF-W)**

- Install the engine guard. (📖 p. 36)
- Unpack and mount the **KTM PowerParts** included in the delivery (optional).

---

**i Info**  
Read the accompanying **KTM PowerParts** fitting instructions.

- 
- Attach the stickers included in the scope of supply (optional).
  - Set kilometers or miles. (📖 p. 39)
  - Set the combination instrument. (📖 p. 39)
  - Set the clock. (📖 p. 40)
  - Refuel. (📖 p. 37)
  - Position all controls in their exact positions on the handlebar. Tighten all screws.
  - Prepare the vehicle according to the specifications in **KTM Dealer.net** for handover to the customer.

---

**i Info**  
Transport mode must be deactivated to be able to start the motorcycle.

---

## 3.1 Raising the motorcycle with the lift stand

### Note

**Danger of damage** The parked vehicle can roll away or fall over.

- Park the vehicle on a firm and level surface.

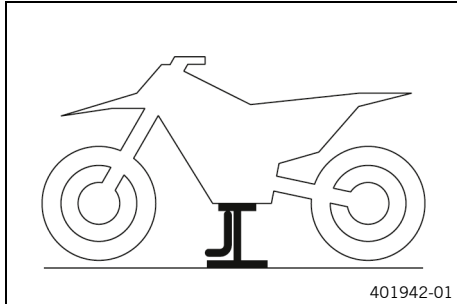

- Raise the motorcycle at the frame underneath the engine.

Lift stand (78129955100)

- ✓ Neither wheel is in contact with the ground.
- Secure the motorcycle against falling over.

## 3.2 Removing the motorcycle from the lift stand

### Note

**Danger of damage** The parked vehicle can roll away or fall over.

- Park the vehicle on a firm and level surface.

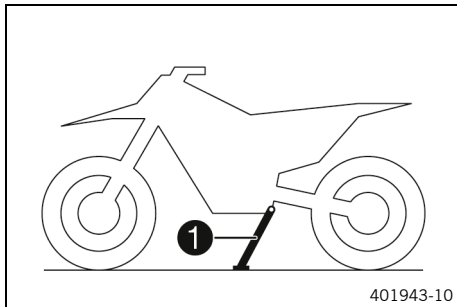

- Remove the motorcycle from the lift stand.
- Remove the lift stand.
- To park the motorcycle, press side stand **1** to the ground with your foot and lean the motorcycle on it.



### Info

When you are riding, the side stand must be folded up and secured with rubber strap.

## 3.3 Removing the headlight mask with the headlight

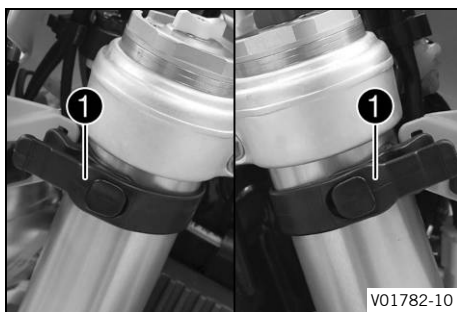

- Detach the brake line and wiring harness from the headlight mask.
- Loosen rubber straps **1**. Slide the headlight mask up and swing it forward.

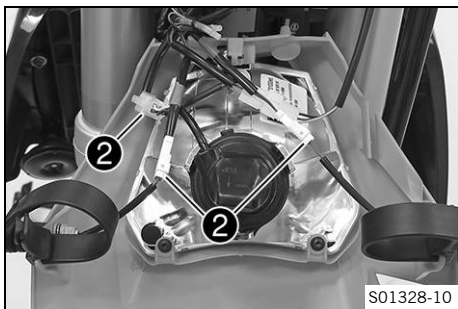

(All EU/AR/ASEAN/BR/CN models, EXC-F US)

- Detach plug-in connectors ② and take off the headlight mask with the headlight.

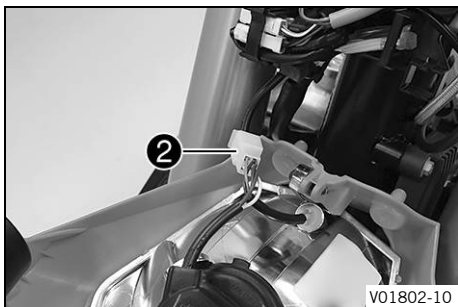

(XCF-W)

- Disconnect plug-in connector ② and take off the headlight mask together with the headlight.

**3.4 Installing the headlight mask with the headlight**

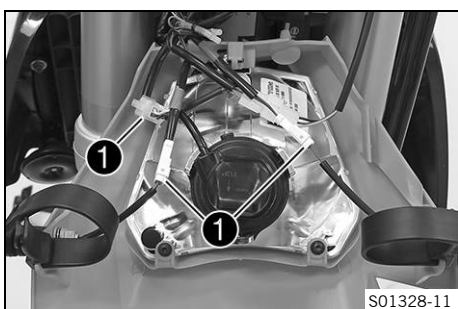

Main work

(All EU/AR/ASEAN/BR/CN models, EXC-F US)

- Join plug-in connectors ①.

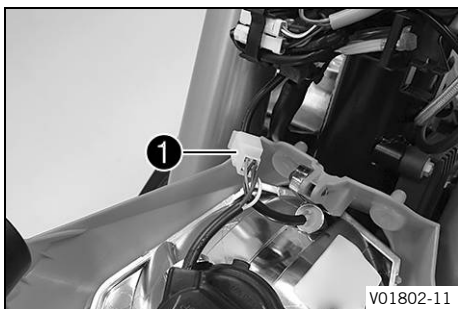

(XCF-W)

- Join plug-in connector ①.

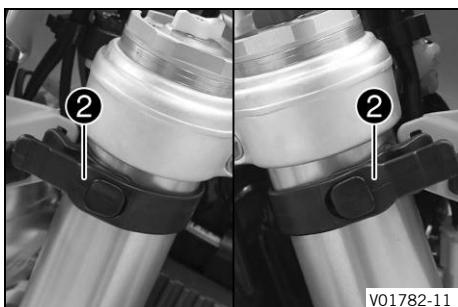

- Position the headlight mask and secure it with rubber straps ②.
- ✓ The holding lugs engage in the fender.
- Position the brake line and wiring harness in the brake line guide.

Finishing work

- Check the headlight setting. (🔧 p. 22)

## 3.5 Checking the headlight setting

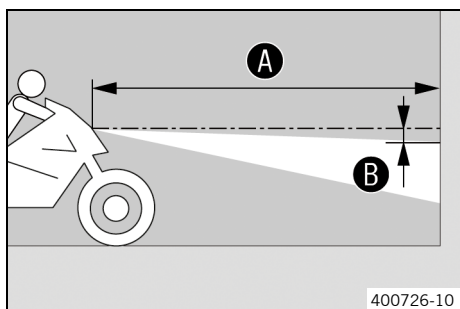

400726-10

- Park the vehicle on a horizontal surface in front of a light-colored wall and make a mark at the height of the center of the low beam headlight.
- Make another mark at a distance **B** under the first marking.

Guideline

Distance <b>B</b>	5 cm (2 in)
-------------------	-------------

- Position the vehicle vertically at a distance **A** away from the wall.

Guideline

Distance <b>A</b>	5 m (16 ft)
-------------------	-------------

- The rider now sits down on the motorcycle.
- Switch on the low beam.
- Check the headlight setting.

The boundary between light and dark must be exactly on the lower mark for a motorcycle with rider.

- » If the boundary between light and dark does not meet specifications:
  - Adjust the headlight range. (📖 p. 22)

## 3.6 Adjusting the headlight range

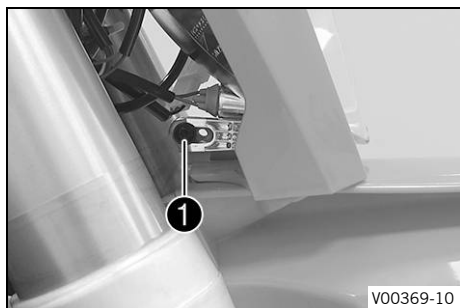

V00369-10

### Preparatory work

- Check the headlight setting. (📖 p. 22)

### Main work

- Loosen screw **1**.
- Adjust the headlight range by pivoting the headlight.

Guideline

The boundary between light and dark must be exactly on the lower mark for a motorcycle with rider (instructions on how to apply the mark: Checking the headlight setting).

### Info

A change in weight on the vehicle may require a correction of the headlight range.

- Tighten screw **1**.



### 3.7 Installing the shock absorber



#### Main work

- Push splash protector ① to the side and position the shock absorber. Mount and tighten screw ②.

#### Guideline

Screw, top shock absorber	M12	80 Nm (59 lbf ft) <b>Loctite®2701™</b>
---------------------------	-----	---

- Mount and tighten screw ③.

#### Guideline

Screw, bottom shock absorber	M12	80 Nm (59 lbf ft) <b>Loctite®2701™</b>
------------------------------	-----	---

#### **i** Info

The heim joint for the shock absorber on the link fork is Teflon coated. It must not be lubricated with grease, nor with any other lubricants. Lubricants dissolve the Teflon coating, thereby drastically reducing the service life.

#### Finishing work

- Remove the motorcycle from the lift stand. (📖 p. 20)



### 3.8 Installing the fork legs

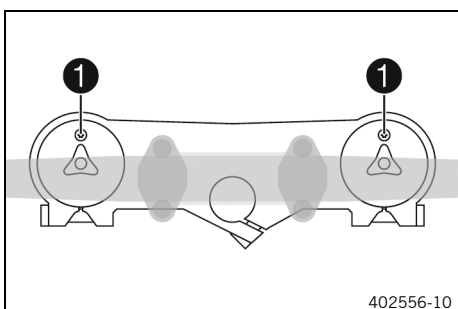

#### Main work

- Position the fork legs.
- ✓ Bleeder screws ① are positioned toward the front.

#### **i** Info

Grooves are milled into the side of the upper end of the fork legs. The second milled groove (from the top) must be flush with the upper edge of the upper triple clamp.

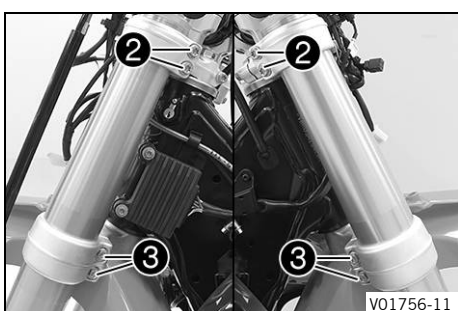

#### (All standard models)

- Tighten screws ②.

#### Guideline

Screw, top triple clamp	M8	20 Nm (14.8 lbf ft)
-------------------------	----	------------------------

- Tighten screws ③.

#### Guideline

Screw, bottom triple clamp	M8	15 Nm (11.1 lbf ft)
----------------------------	----	------------------------

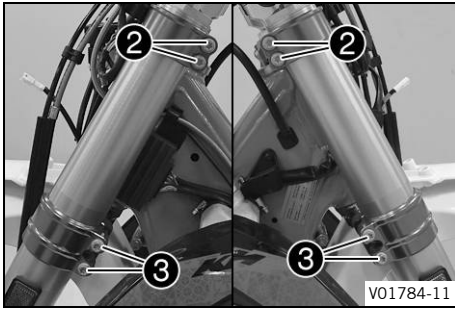

**(All special models)**

- Tighten screws **2**.

Guideline

Screw, top triple clamp	M8	17 Nm (12.5 lbf ft)
-------------------------	----	------------------------

- Tighten screws **3**.

Guideline

Screw, bottom triple clamp	M8	15 Nm (11.1 lbf ft)
----------------------------	----	------------------------

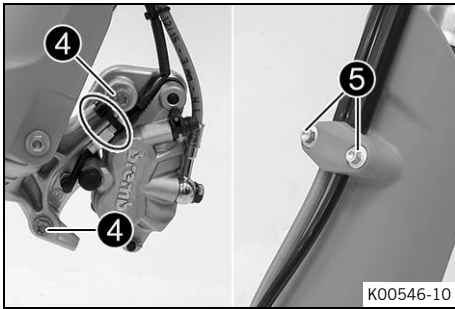

- Position the brake caliper, and mount and tighten screws **4**.

Guideline

Screw, front brake caliper	M8	25 Nm (18.4 lbf ft) <b>Loctite®243™</b>
----------------------------	----	--

- Mount the cable ties.
- Position the brake line, the wiring harness, and the clamp. Mount and tighten screws **5**.

**Finishing work**

- Install the front wheel. (📖 p. 24)
- Install the headlight mask with the headlight. (📖 p. 21)
- Check the headlight setting. (📖 p. 22)

## 3.9 Installing the front wheel



**Warning**

**Danger of accidents** Oil or grease on the brake discs reduces the braking effect.

- Always keep the brake discs free of oil and grease.
- Clean the brake discs with brake cleaner when necessary.

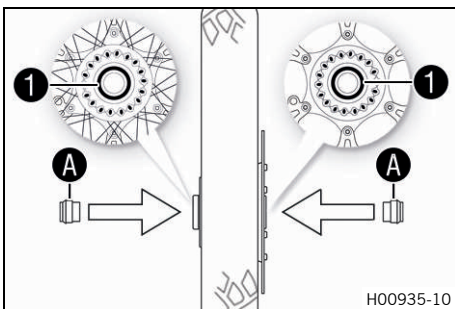

- Check the wheel bearing for damage and wear.
  - » If the wheel bearing is damaged or worn:
    - Change front wheel bearing.
- Clean and grease shaft seal rings **1** and contact surfaces **A** of the spacers.

Long-life grease (📖 p. 45)

- Clean and lightly grease the wheel spindle.

Long-life grease (📖 p. 45)

- Insert the spacers.
- Position the front wheel and insert the wheel spindle.
  - ✓ The brake linings are correctly positioned.

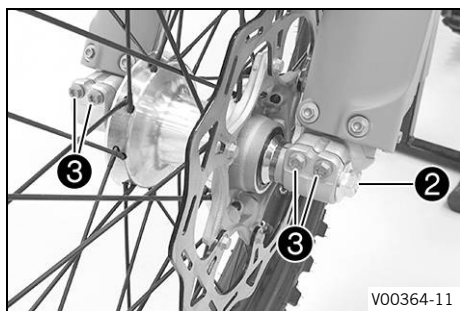

- Mount and tighten screw ②.

Guideline

Screw, front wheel spindle	M20x1.5	35 Nm (25.8 lbf ft)
----------------------------	---------	---------------------

- Operate the hand brake lever several times until the brake linings are seated correctly against the brake disc.
- Remove the motorcycle from the lift stand. (📖 p. 20)
- Operate the front brake and compress the fork a few times firmly.

✓ The fork legs straighten.

- Tighten screws ③.

Guideline

Screw, fork stub	M8	15 Nm (11.1 lbf ft)
------------------	----	---------------------

### 3.10 Installing front fender

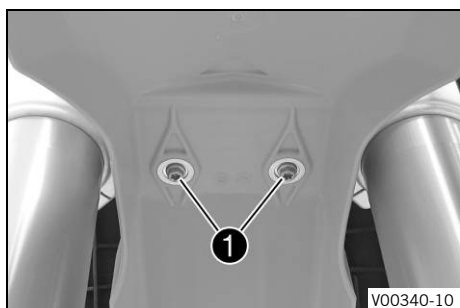

#### Main work

##### (All standard models)

- Position front fender. Mount and tighten screws ①.

Guideline

Remaining screws, chassis	M6	10 Nm (7.4 lbf ft)
---------------------------	----	--------------------

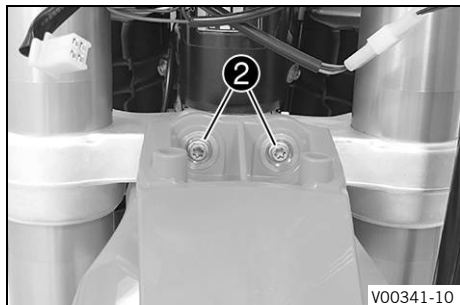

- Mount and tighten screws ②.

Guideline

Remaining screws, chassis	M6	10 Nm (7.4 lbf ft)
---------------------------	----	--------------------

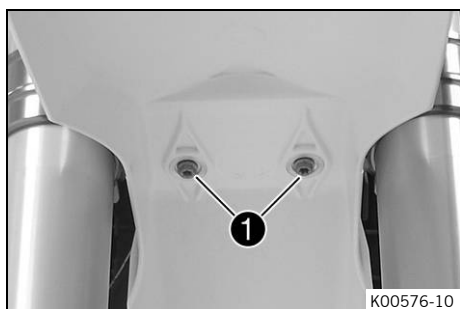

##### (All special models)

- Position front fender. Mount and tighten screws ①.

Guideline

Remaining screws, chassis	M6	10 Nm (7.4 lbf ft)
---------------------------	----	--------------------

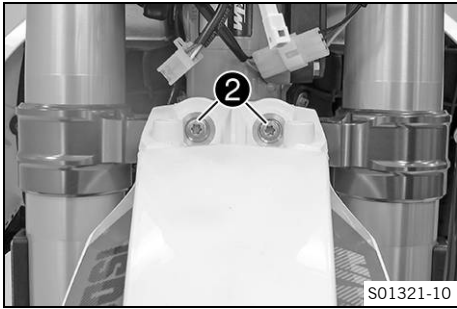

- Mount and tighten screws ②.

Guideline

Remaining screws, chassis	M6	10 Nm (7.4 lbf ft)
---------------------------	----	--------------------

### Finishing work

- Install the headlight mask with the headlight. (📖 p. 21)
- Check the headlight setting. (📖 p. 22)

## 3.11 Removing the seat

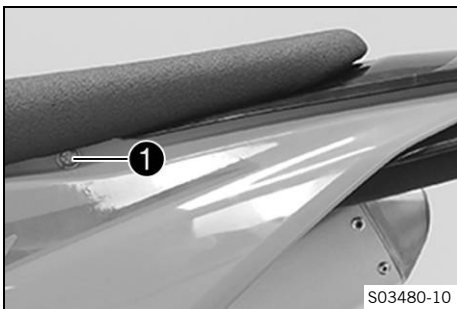

- Remove screw ①.

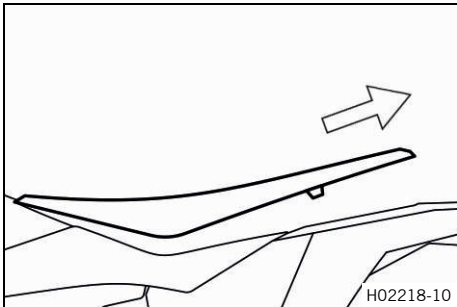

- Raise the rear of the seat, pull the seat back, and lift it off.

## 3.12 Mounting the seat

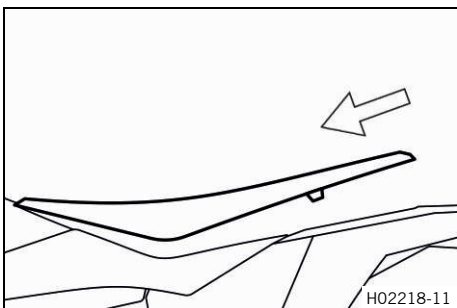

- Mount the front of the seat on the collar bushings of the fuel tank, lower the seat at the rear, and push the seat forward.
- Make sure the seat is locked in correctly.

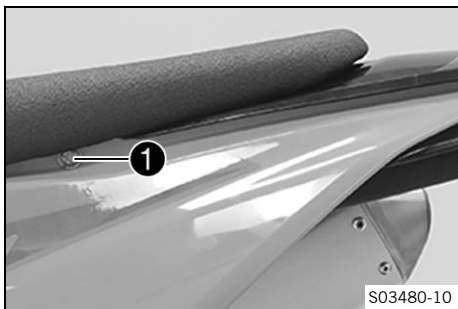

- Mount and tighten screw ❶.

Guideline

Remaining screws, chassis	M6	10 Nm (7.4 lbf ft)
---------------------------	----	--------------------

### 3.13 Removing the 12-V battery



**Note**

**Environmental hazard** 12 V batteries contain environmentally hazardous materials.

- Do not dispose of 12 V batteries as household waste.
- Dispose of 12 V batteries at a collection point for used batteries.



**Note**

**Environmental hazard** Hazardous substances cause environmental damage.

- Dispose of oils, grease, filters, fuel, cleaning agents, brake fluid, etc., correctly and in compliance with the applicable regulations.

**Preparatory work**

- Remove the seat. (🛠️ p. 26)

**Main work**

(All EU/US/ASEAN/CN models)

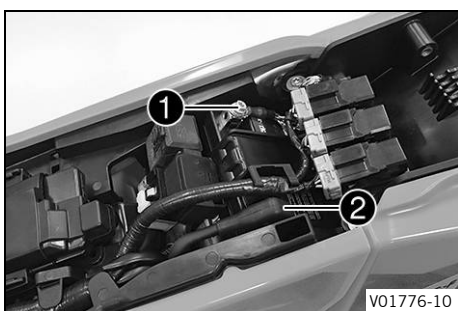

**Warning**

**Risk of injury** 12 V batteries contain harmful substances.

- Keep 12 V batteries out of the reach of children.
- Keep sparks and open flames away from 12 V batteries.
- Only charge 12 V batteries in well-ventilated rooms.
- Maintain a minimum clearance from inflammable materials when charging 12 V batteries.  
Minimum clearance 1 m (3 ft)
- Do not charge deeply discharged 12 V batteries if the charge is already below the minimum voltage.  
Minimum voltage 9 V before the start of the charge
- Dispose of 12 V batteries with less than the minimum voltage correctly.

- Disconnect negative cable ❶ from the 12-V battery.

- Pull back positive terminal cover **2** and disconnect the positive cable from the 12-V battery.

(EXC-F AR/BR, EXC-F SIX DAYS BR)



### Warning

**Risk of injury** Battery acid and battery gases cause serious chemical burns.

- Keep 12 V batteries out of the reach of children.
- Wear suitable protective clothing and safety glasses.
- Avoid contact with battery acid and battery gases.
- Keep sparks or open flames away from the 12 V battery.
- Only charge 12 V batteries in well-ventilated rooms.
- Rinse the affected area immediately with plenty of water in the event of contact with the skin.
- Rinse eyes with water for at least 15 minutes and consult a doctor immediately if battery acid and battery gases get into the eyes.

- Disconnect negative cable **1** from the 12-V battery.
- Pull back positive terminal cover **2** and disconnect the positive cable from the 12-V battery.
- Pull off starter relay **3** and fuse box **4** from the battery compartment and hang to the side.

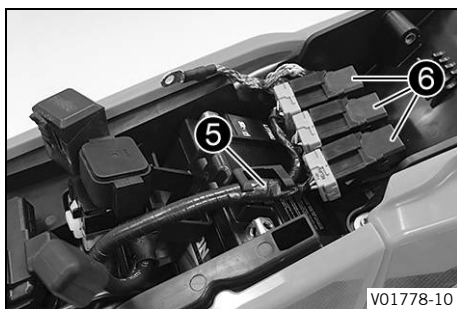
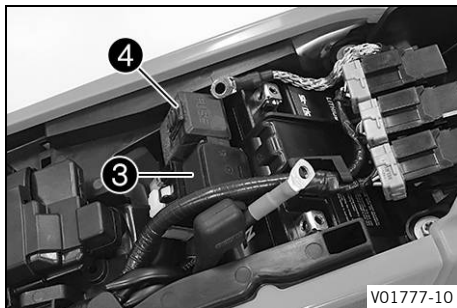

- Detach wiring harness **5**, disconnect relays **6** and hang them to the side.



- Remove screw 7 and detach the battery compartment.
- Lift out the 12-V battery.

### 3.14 Installing the 12-V battery

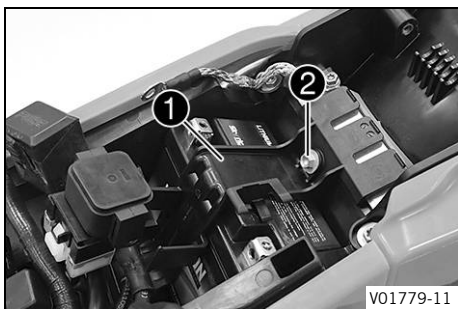

**Main work**

- Insert the 12-V battery into the battery compartment with the terminals facing forward and secure with holding bracket 1.

**(All EU/US/ASEAN/CN models)**

12-V battery (HJTZ5S-FP-C)
----------------------------

**(EXC-F AR/BR, EXC-F SIX DAYS BR)**

12-V battery (YTX5L-BS)
-------------------------

- Mount and tighten screw 2.

**Guideline**

Remaining screws, chassis	M6	10 Nm (7.4 lbf ft)
---------------------------	----	--------------------

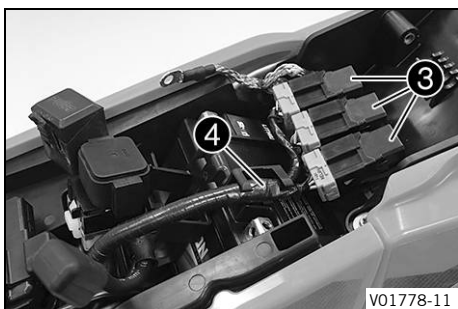

- Mount relays 3 and attach wiring harness 4.

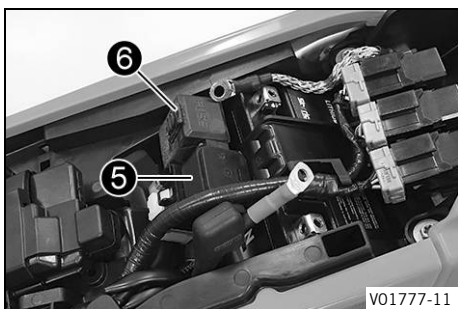

- Mount starter relay 5 and fuse box 6.

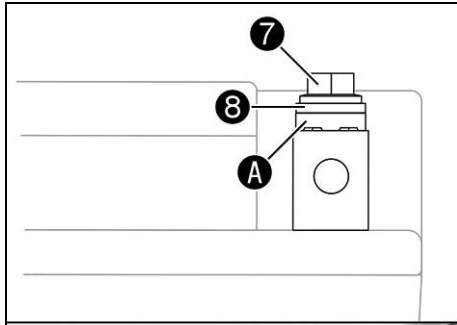

- Connect the positive cable to the 12-V battery.

Guideline

Screw, battery terminal	M5	2.5 Nm (1.84 lbf ft)
-------------------------	----	-------------------------

**i Info**

Contact disk **A** must be mounted under screw **7** and cable lug **8** with the claws toward the battery terminal.

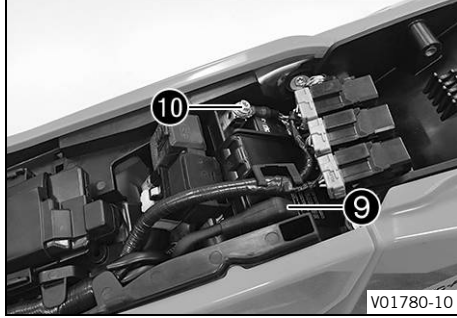

- Slide positive terminal cover **9** over the positive terminal.
- Connect negative cable **10** to the 12-V battery.

Guideline

Screw, battery terminal	M5	2.5 Nm (1.84 lbf ft)
-------------------------	----	-------------------------

**i Info**

Contact disk **A** must be mounted under screw **7** and cable lug **8** with the claws toward the battery terminal.

**Finishing work**

- Mount the seat. (📖 p. 26)

## 3.15 Disconnecting the negative cable of the 12-V battery

**Preparatory work**

- Remove the seat. (📖 p. 26)

**Main work**

- Disconnect negative cable **1** of the 12-V battery.

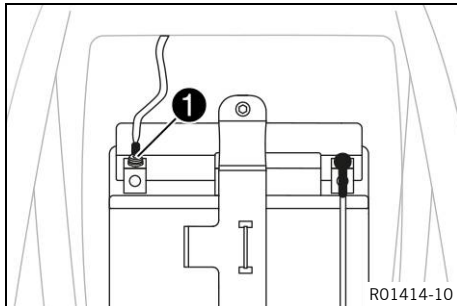



**3.16 Connecting the negative cable of the 12-V battery**

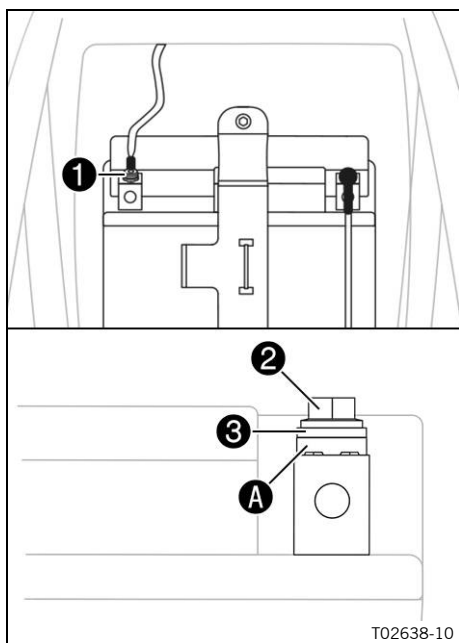

**Main work**

- Connect negative cable ① of the 12-V battery.

**Guideline**

Screw, battery terminal	M5	2.5 Nm (1.84 lbf ft)
-------------------------	----	-------------------------

Contact disk A must be mounted under screw ② and cable lug ③ with the claws toward the battery terminal.

**Finishing work**

- Mount the seat. (📖 p. 26)



**3.17 Charging the 12-V battery (All EU/US/ASEAN/CN models)**



**Warning**

**Risk of injury** 12 V batteries contain harmful substances.

- Keep 12 V batteries out of the reach of children.
- Keep sparks and open flames away from 12 V batteries.
- Only charge 12 V batteries in well-ventilated rooms.
- Maintain a minimum clearance from inflammable materials when charging 12 V batteries.  
Minimum clearance 1 m (3 ft)
- Do not charge deeply discharged 12 V batteries if the charge is already below the minimum voltage.  
Minimum voltage before the start of the charge 9 V
- Dispose of 12 V batteries with less than the minimum voltage correctly.

**Note**

**Danger of damage** An incorrectly selected charging mode will damage the 12-V battery.

- Always select a charging mode that is compatible with the type of battery.



**Note**

**Environmental hazard** 12 V batteries contain environmentally hazardous materials.

- Do not dispose of 12 V batteries as household waste.
- Dispose of 12 V batteries at a collection point for used batteries.



**Note**

**Environmental hazard** Hazardous substances cause environmental damage.

- Dispose of oils, grease, filters, fuel, cleaning agents, brake fluid, etc., correctly and in compliance with the applicable regulations.

**i Info**

Even when there is no load on the 12-V battery, it discharges steadily each day. The charging level and the method of charging are very important for the service life of the 12-V battery. Rapid recharging with a high charging current shortens the service life of the battery. If the charging current, charging voltage, and charging time are exceeded, the 12-V battery will be destroyed. If the 12-V battery is depleted from starting the vehicle repeatedly, the battery must be charged immediately. If the 12-V battery is left in a discharged state for an extended period, it will become deeply discharged and suffer a loss of capacity, destroying the battery. The 12-V battery is maintenance-free.

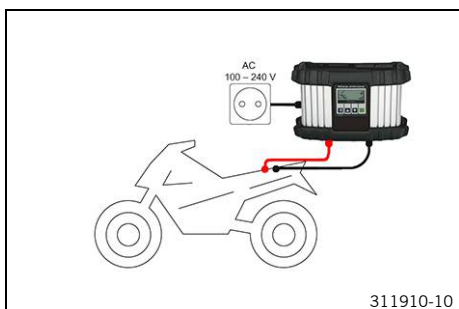

**Preparatory work**

- Remove the seat. (📖 p. 26)
- Disconnect the negative cable of the 12-V battery. (📖 p. 30)

**Main work**

- Connect a battery charger to the 12-V battery. Adjust the battery charger.

EU battery charger **XCharge-professional** (00029095050)

**Alternative 1**

US battery charger **XCharge-professional** (00029095051)

**Alternative 2**

UK battery charger **XCharge-professional** (00029095052)

**i Info**

Follow the instructions of the charger and the manual.

- Disconnect the battery charger after charging the 12-V battery.
- Guideline

The charging current, charging voltage, and charging time must not be exceeded.	
Recharge the 12-V battery regularly when the motorcycle is not being used	3 months

**Finishing work**

- Connect the negative cable of the 12-V battery. (📖 p. 31)
- Mount the seat. (📖 p. 26)

**3.18 Charging the 12-V battery (EXC-F AR/BR, EXC-F SIX DAYS BR)**



**Warning**

**Risk of injury** Battery acid and battery gases cause serious chemical burns.

- Keep 12 V batteries out of the reach of children.
- Wear suitable protective clothing and safety glasses.
- Avoid contact with battery acid and battery gases.
- Keep sparks or open flames away from the 12 V battery.
- Only charge 12 V batteries in well-ventilated rooms.
- Rinse the affected area immediately with plenty of water in the event of contact with the skin.
- Rinse eyes with water for at least 15 minutes and consult a doctor immediately if battery acid and battery gases get into the eyes.



**Note**

**Environmental hazard** 12 V batteries contain environmentally hazardous materials.

- Do not dispose of 12 V batteries as household waste.
- Dispose of 12 V batteries at a collection point for used batteries.



**Note**

**Environmental hazard** Hazardous substances cause environmental damage.

- Dispose of oils, grease, filters, fuel, cleaning agents, brake fluid, etc., correctly and in compliance with the applicable regulations.



**Info**

Even when there is no load on the 12-V battery, it discharges steadily each day. The charging level and the method of charging are very important for the service life of the 12-V battery. Rapid recharging with a high charging current shortens the service life of the battery. If the charging current, charging voltage, or charging time is exceeded, the 12-V battery will be destroyed. If the 12-V battery is depleted by repeated starting, the 12-V battery must be charged immediately. If the 12-V battery is left in a discharged state for an extended period, it will become deeply discharged and sulfating occurs, destroying the battery. The 12-V battery is maintenance-free, i.e. the acid level does not have to be checked.

**Preparatory work**

- Remove the seat. (📖 p. 26)
- Disconnect the negative cable of the 12-V battery. (📖 p. 30)

**Main work**

- Connect a battery charger to the 12-V battery. Adjust the battery charger.

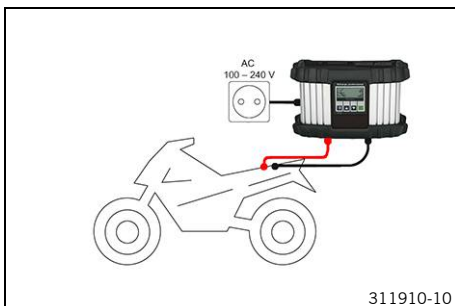

EU battery charger **XCharge-professional** (00029095050)

**Alternative 1**

US battery charger **XCharge-professional** (00029095051)

**Alternative 2**

UK battery charger **XCharge-professional** (00029095052)



**Info**

Follow the instructions of the charger and the manual.

- Disconnect the battery charger after charging the 12-V battery.

**Guideline**

The charging current, charging voltage, and charging time must not be exceeded.

Recharge the 12-V battery regularly when the motorcycle is not being used	3 months
---	----------

**Finishing work**

- Connect the negative cable of the 12-V battery. (📖 p. 31)
- Mount the seat. (📖 p. 26)

## 3.19 Removing the air filter box cover

**Condition**

The air filter box cover is secured.

- Remove the seat. (📖 p. 26)
- Remove screw ①.

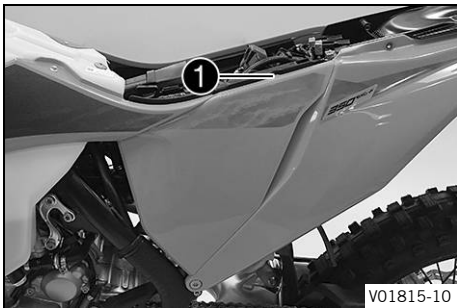

V01815-10

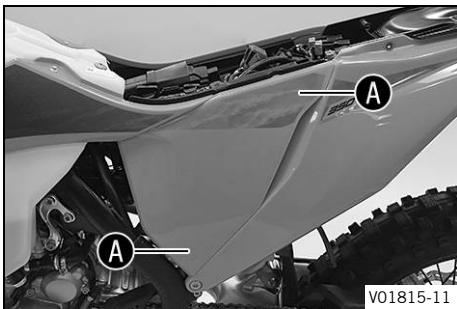

V01815-11

- Pull off the air filter box cover in area A laterally and take it off at the front.

**Condition**

The air filter box cover is not secured.

- Pull off the air filter box cover in area A laterally and take it off at the front.

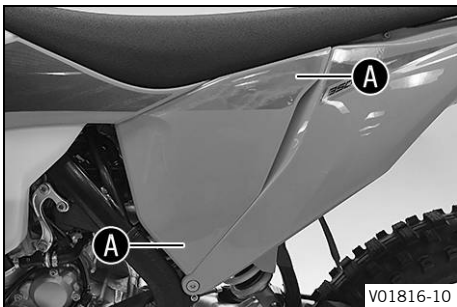

V01816-10

### 3.20 Installing the air filter box cover

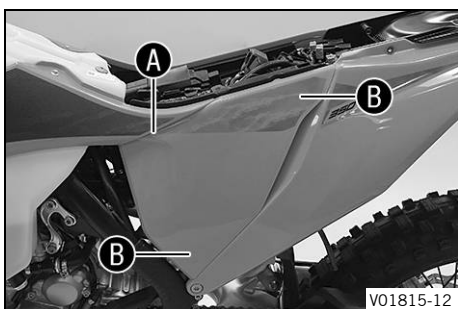

**Condition**

The air filter box cover is secured.

- Insert the air filter box cover in area **A** and clip it into area **B**.

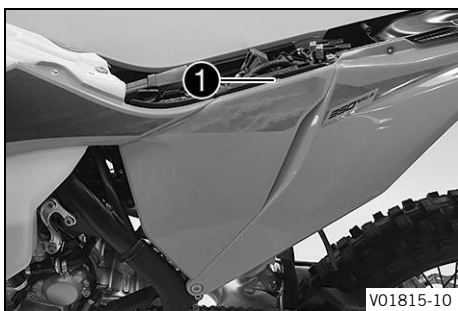

- Mount and tighten screw **1**.

Guideline

Screw, air filter box cover	EJOT PT® K60x20-Z	3 Nm (2.2 lbf ft)
-----------------------------	----------------------	-------------------

- Mount the seat. (📖 p. 26)

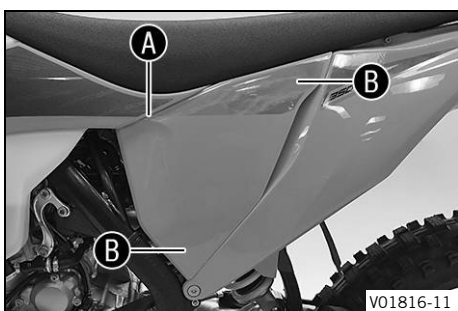

**Condition**

The air filter box cover is not secured.

- Insert the air filter box cover in area **A** and clip it into area **B**.

### 3.21 Removing the rear left side cover



- Remove screw **1** and take off fairing part to the front.

## 3.22 Installing the rear left side cover

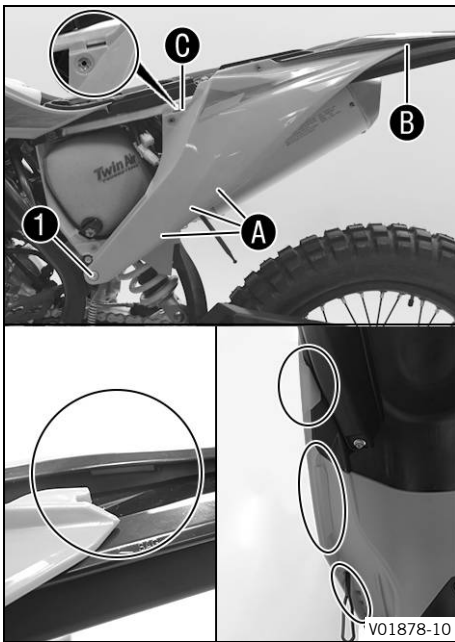

- Position side cover and hook it in in areas **A**, **B** and **C**.
- Mount and tighten screw **1**.

Guideline

Screw, sub-frame top	M8	35 Nm (25.8 lbf ft) <b>Loctite®2701™</b>
----------------------	----	---

## 3.23 Installing the engine guard (All special models, XCF-W)

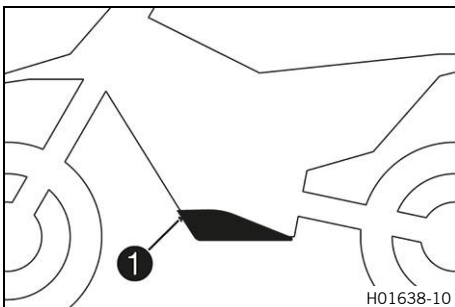

- Attach the engine guard on the frame at the rear and swing up at the front.
- Mount and tighten screws **1**.

Guideline

Remaining screws, chassis	M6	10 Nm (7.4 lbf ft)
---------------------------	----	--------------------

## 3.24 Opening the fuel tank filler cap



### Danger

**Fire hazard** Fuel is highly flammable.

The fuel in the fuel tank expands when warm and can escape if overfilled.

- Do not fuel the vehicle in the vicinity of open flames or lit cigarettes.
- Switch off the engine for refueling.
- Make sure that no fuel is spilled; particularly not on hot parts of the vehicle.
- If any fuel is spilled, wipe it off immediately.
- Observe the specifications for refueling.



**Warning**

**Danger of poisoning** Fuel is poisonous and a health hazard.

- Avoid skin, eye and clothing contact with fuel.
- Immediately consult a doctor if you swallow fuel.
- Do not inhale fuel vapors.
- In case of skin contact, rinse the affected area with plenty of water.
- Rinse the eyes thoroughly with water, and consult a doctor in case of fuel contact with the eyes.
- Change your clothing in case of fuel spills on them.
- Keep fuels correctly in a suitable canister, and out of the reach of children.



**Note**

**Environmental hazard** Improper handling of fuel is a danger to the environment.

- Do not allow fuel to enter the groundwater, the soil, or the sewage system.

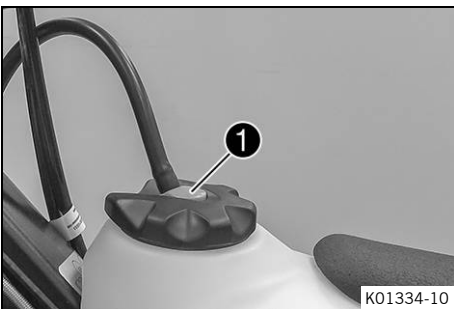

- Press release button **1**, turn the fuel tank filler cap counter-clockwise, and lift it off.

**3.25 Closing the fuel tank filler cap**

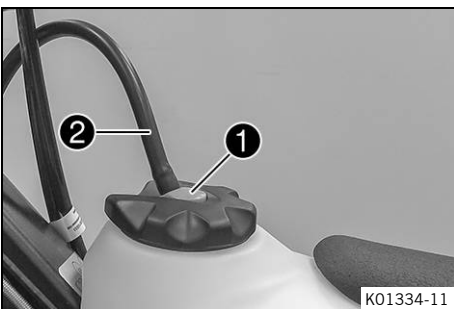

- Mount the fuel tank filler cap and turn it clockwise until release button **1** engages.



**Info**

Route fuel tank breather hose **2** without kinks.

**3.26 Refueling**



**Danger**

**Fire hazard** Fuel is highly flammable.

The fuel in the fuel tank expands when warm and can escape if overfilled.

- Do not fuel the vehicle in the vicinity of open flames or lit cigarettes.
- Switch off the engine for refueling.
- Make sure that no fuel is spilled; particularly not on hot parts of the vehicle.
- If any fuel is spilled, wipe it off immediately.
- Observe the specifications for refueling.



## Warning

**Danger of poisoning** Fuel is poisonous and a health hazard.

- Avoid skin, eye and clothing contact with fuel.
- Immediately consult a doctor if you swallow fuel.
- Do not inhale fuel vapors.
- In case of skin contact, rinse the affected area with plenty of water.
- Rinse the eyes thoroughly with water, and consult a doctor in case of fuel contact with the eyes.
- Change your clothing in case of fuel spills on them.

## Note

**Material damage** Inadequate fuel quality causes the fuel filter to quickly become clogged.

In some countries and regions, the available fuel quality and cleanliness may not be sufficient. This will result in problems with the fuel system.

- Refuel only with clean fuel that meets the specified standards.



## Note

**Environmental hazard** Improper handling of fuel is a danger to the environment.

- Do not allow fuel to enter the groundwater, the soil, or the sewage system.

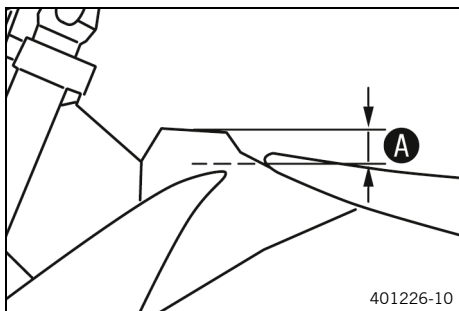

- Switch off the engine.
- Open the fuel tank filler cap. (🔧 p. 36)
- Fill the fuel tank with fuel up to a maximum of level **A**.

Guideline

Dimension <b>A</b>	35 mm (1.38 in)
--------------------	-----------------

### (All EU/AR/ASEAN/BR/CN models)

Total fuel tank capacity, approx.	9.25 l (2.444 US gal)	Super unleaded (ROZ 95) (🔧 p. 44) (All EU/AR/CN/ASEAN models)
Total fuel tank capacity, approx.		Super unleaded, type C (ROZ 95/RON 95/PON 91) (🔧 p. 44) (All BR models)

### (XCF-W, EXC-F US)

Total fuel tank capacity, approx.	8.5 l (2.25 US gal)	Super unleaded (ROZ 95) (🔧 p. 44)
-----------------------------------	------------------------	--------------------------------------

- Close the fuel tank filler cap. (🔧 p. 37)



### 3.27 Setting kilometers or miles

**i** **Info**

If you change the unit, the value **ODO** is retained and converted accordingly. The values **TR1**, **TR2**, **A1**, **A2** and **S1** are cleared when the unit of measure is changed.

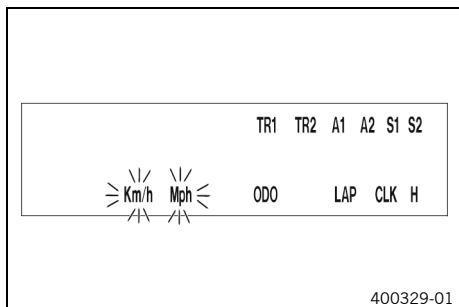

**Condition**

The motorcycle is stationary.

- Repeatedly press the button **+** briefly until **H** appears at the bottom right of the display.
- Press the button **+** for 2–3 seconds.
  - ✓ The Setup menu is displayed and the active functions are shown.
- Repeatedly press the button **+** briefly until **Km/h/Mph** flashes.

**Adjusting the Km/h**

- Press the button **+**.

**Adjusting the Mph**

- Press the button **-**.
- Wait 3 - 5 seconds.
  - ✓ The settings are stored.

**i** **Info**

If no button is pressed for 10–12 seconds, or if an impulse comes from the wheel speed sensor, the settings are automatically saved and the setup menu is closed.



### 3.28 Setting the combination instrument

**i** **Info**

When the vehicle is delivered, only the **SPEED/H** and **SPEED/ODO** display modes are activated.

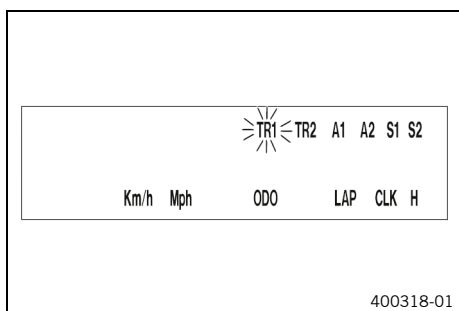

**Condition**

The motorcycle is stationary.

- Repeatedly press the button **+** briefly until **H** appears at the bottom right of the display.
- Press the button **+** for 2–3 seconds.
  - ✓ The Setup menu is displayed and the active functions are shown.

**i** **Info**

If no button is pressed for 10–12 seconds, the settings are automatically saved. If no button is pressed for 20 seconds, or if an impulse comes from the wheel speed sensor, the settings are automatically saved and the setup menu is closed.

- Repeatedly press the button **+** briefly until the desired function flashes.
  - ✓ The selected function flashes.

**Activating the function**





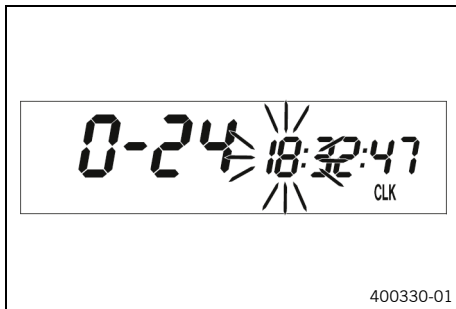

- Press the button .
- ✓ The symbol continues to appear in the display and the next function appears.

**Deactivating a function**

- Press the button .
- ✓ The symbol disappears in the display and the next function appears.

**3.29 Setting the clock****Condition**

The motorcycle is stationary.

- Repeatedly press the button  briefly until **CLK** appears at the bottom right of the display.
- Press the button  for 2–3 seconds.
  - ✓ The hour display flashes.
- Adjust hour display with the button  and/or button .
- Wait 3 - 5 seconds.
  - ✓ The next segment of the display flashes and can be set.
- You can set the following segments in the same way as the hours by pressing the button  and the button .

**i Info**

The seconds can only be set to zero.  
If no button is pressed for 15-20 seconds, or if an impulse comes from the wheel speed sensor, the settings are automatically saved and the setup menu is closed.

**4.1 Chassis tightening torques**

Nozzle, crank chamber ventilation	M4	2 Nm (1.5 lbf ft)	<b>Loctite®243™</b>
Oil nozzle for clutch lubrication	M4	2 Nm (1.5 lbf ft)	<b>Loctite®243™</b>
Oil nozzle for conrod bearing lubrication	M4	2 Nm (1.5 lbf ft)	<b>Loctite®243™</b>
Oil nozzle for main bearing lubrication	M4	2 Nm (1.5 lbf ft)	<b>Loctite®243™</b>
Screw, hose clip, inlet sleeve	M4	3 Nm (2.2 lbf ft)	
Screw, oil jet for piston cooling	M4	2.5 Nm (1.84 lbf ft)	<b>Loctite®243™</b>
Locking screw for bearing	M5	6 Nm (4.4 lbf ft)	<b>Loctite®243™</b>
Oil channel screw plug in alternator cover	M5	2 Nm (1.5 lbf ft)	<b>Loctite®243™</b>
Oil nozzle for cam lever lubrication	M5	3 Nm (2.2 lbf ft)	<b>Loctite®243™</b>
Oil nozzle, piston cooling	M5	2 Nm (1.5 lbf ft)	<b>Loctite®243™</b>
Screw, bearing bolt, oil pump idler gear	M5	6 Nm (4.4 lbf ft)	<b>Loctite®243™</b>
Screw, clutch spring retainer	M5	6 Nm (4.4 lbf ft)	
Screw, crankshaft speed sensor	M5	6 Nm (4.4 lbf ft)	<b>Loctite®243™</b>
Screw, gear position sensor	M5	5 Nm (3.7 lbf ft)	<b>Loctite®243™</b>
Screw, locking lever	M5	6 Nm (4.4 lbf ft)	<b>Loctite®243™</b>
Screw, oil pump cover	M5	6 Nm (4.4 lbf ft)	<b>Loctite®243™</b>
Screw, stator	M5	6 Nm (4.4 lbf ft)	<b>Loctite®2701™</b>
Nut, cylinder head	M6	10 Nm (7.4 lbf ft) Lubricated with engine oil	
Nut, water pump impeller	M6	6 Nm (4.4 lbf ft)	<b>Loctite®243™</b>
Screw, alternator cover	M6	10 Nm (7.4 lbf ft)	
Screw, clutch cover	M6	10 Nm (7.4 lbf ft)	
Screw, clutch slave cylinder	M6	10 Nm (7.4 lbf ft)	
Screw, engine case	M6	10 Nm (7.4 lbf ft)	
Screw, exhaust flange	M6	10 Nm (7.4 lbf ft)	<b>Loctite®243™</b>
Screw, fuel vapor retention system connection	M6	5 Nm (3.7 lbf ft)	<b>Loctite®2701™</b>
Screw, fuel vapor retention system lock	M6	5 Nm (3.7 lbf ft)	<b>Loctite®243™</b>
Screw, guide rail	M6	10 Nm (7.4 lbf ft)	<b>Loctite®243™</b>

## 4 TECHNICAL DATA

Screw, oil filter cover	M6	10 Nm (7.4 lbf ft)
Screw, shift drum locating	M6	10 Nm (7.4 lbf ft) <b>Loctite®243™</b>
Screw, shift lever	M6	14 Nm (10.3 lbf ft) <b>Loctite®243™</b>
Screw, starter motor	M6	10 Nm (7.4 lbf ft)
Screw, starter motor - intermediate gear	M6	10 Nm (7.4 lbf ft) <b>Loctite®243™</b>
Screw, timing chain failure protection	M6	10 Nm (7.4 lbf ft) <b>Loctite®243™</b>
Screw, valve cover	M6	8 Nm (5.9 lbf ft)
Screw, water pump cover	M6	10 Nm (7.4 lbf ft)
Stud, cylinder head	M6	10 Nm (7.4 lbf ft)
Screw, auto decompression	M7x1	15 Nm (11.1 lbf ft) <b>Loctite®243™</b>
Screw, camshaft bearing bridge	M7x1	Tightening sequence: Tighten diagonally. 1st tightening stage 5 Nm (3.7 lbf ft) 2nd tightening stage 14 Nm (10.3 lbf ft) Lubricated with engine oil
Crankshaft clamp screw plug	M8	10 Nm (7.4 lbf ft)
Screw, tensioning rail	M8	15 Nm (11.1 lbf ft) <b>Loctite®243™</b>
Screw, engine sprocket	M10	60 Nm (44.3 lbf ft) <b>Loctite®243™</b>
Plug, oil channel	M10x1	15 Nm (11.1 lbf ft) <b>Loctite®243™</b>
Screw plug, cam lever axis	M10x1	10 Nm (7.4 lbf ft)
Screw, rotor	M10x1	70 Nm (51.6 lbf ft) Collar and thread oiled / cone degreased
Screw, unlocking of timing chain tensioner	M10x1	8 Nm (5.9 lbf ft)
Spark plug	M10x1	12 Nm (8.9 lbf ft)
Coolant temperature sensor	M10x1.25	12 Nm (8.9 lbf ft)
Nut, cylinder head	M10x1.25	Tightening sequence: Tighten diagonally. 1st tightening stage 10 Nm (7.4 lbf ft) 2nd tightening stage 30 Nm (22.1 lbf ft) 3rd tightening stage 180°
Stud, cylinder head	M10x1.25	20 Nm (14.8 lbf ft) <b>Loctite®243™</b>
Oil drain plug with magnet	M12x1.5	20 Nm (14.8 lbf ft)
Screw plug, oil pressure control valve	M12x1.5	20 Nm (14.8 lbf ft)
Oil drain plug	M14x1.5	15 Nm (11.1 lbf ft)

Nut, inner clutch hub	M18x1.5	100 Nm (73.8 lbf ft) <b>Loctite®243™</b>
Nut, primary gear wheel	M18LHx1.5	120 Nm (88.5 lbf ft) <b>Loctite®243™</b>
Screw plug, oil screen	M20x1.5	15 Nm (11.1 lbf ft)
Plug, timing chain tensioner	M24x1.5	40 Nm (29.5 lbf ft)
Screw, alternator cover	M24x1.5	18 Nm (13.3 lbf ft)

### Super unleaded (ROZ 95)

#### Standard/classification

- DIN EN 228 (ROZ 95)

#### Guideline

- Only use super unleaded fuel that matches or is equivalent to the specified standard.
- Fuel with an ethanol content of up to 10% (E10 fuel) is safe to use.



#### Info

Do **not** use fuel containing methanol (e.g., M15, M85, M100) or more than 10% ethanol (e.g., E15, E25, E85, E100).

---

### Super unleaded, type C (ROZ 95/RON 95/PON 91)

#### Standard/classification

- ANP (Agência Nacional do Petróleo) #57 (ROZ 95/RON 95/PON 91)

#### Guideline

- Only use super unleaded fuel that matches or is equivalent to the following specifications.
- Super unleaded fuel with an ethanol content of 19 to 27% is permissible.



#### Info

Do **not** use fuel made of methanol (e.g., M15, M85, M100).  
Do **not** use fuel with less than 19% ethanol (e.g., E10).  
Do **not** use fuel with more than 27% ethanol (e.g., E30, E85, E100).

---

## Long-life grease

Recommended supplier

MOTOREX®

– Bike Grease 2000



3214519en

09/2021

