

1290 SUPER DUKE GT

ART. NO. 3214550EN



Congratulations on your decision to purchase a KTM motorcycle. You are now the owner of a state-of-the-art sports vehicle which, with appropriate care, will bring you pleasure for a long time to come.

We wish you good and safe riding at all times!

Enter the serial numbers of your vehicle below.

Vehicle identification number (📖 p. 14)	Dealer's stamp
Engine number (📖 p. 15)	
Key number (📖 p. 14)	

The Owner's Manual contained the latest information for this model series at the time of publication. However, minor differences due to further developments in design cannot be ruled out completely.

All specifications contained herein are non-binding. KTM Sportmotorcycle GmbH specifically reserves the right to modify or delete technical specifications, prices, colors, forms, materials, services, designs, equipment, etc., without prior notice and without specifying reasons, to adapt these to local conditions, as well as to stop production of a particular model without prior notice. KTM accepts no liability for delivery options, deviations from figures and descriptions, misprints, and other errors. The models portrayed partly contain special equipment that does not belong to the regular scope of supply.

© 2021 KTM Sportmotorcycle GmbH, Mattighofen Austria

All rights reserved

Reproduction, even in part, as well as copying of all kinds, is permitted only with the express written permission of the copyright owner.



ISO 9001(12 100 6061)

KTM applies quality assurance processes that lead to the highest possible product quality as defined in the ISO 9001 international quality management standard.

Issued by: TÜV Management Service

REG.NO. 12 100 6061

KTM Sportmotorcycle GmbH
Stallhofnerstraße 3
5230 Mattighofen, Austria

This document is valid for the following models:

1290 SUPER DUKE GT EU (F9903VF)

1290 SUPER DUKE GT CN (F9987VF)

1290 SUPER DUKE GT JP (F9986VF)



3214550en

12/2021

TABLE OF CONTENTS

1	MEANS OF REPRESENTATION	6	6.15	C1 and C2 switch	21
1.1	Symbols used	6	6.16	RACE-ON key	21
1.2	Formats used.....	6	6.17	Steering lock (antenna).....	22
2	SAFETY ADVICE.....	7	6.18	Immobilizer	22
2.1	Use definition – intended use.....	7	6.19	Socket for electrical accessories	22
2.2	Misuse.....	7	6.20	USB socket	23
2.3	Safety advice.....	7	6.21	Connecting the USB cable	23
2.4	Degrees of risk and symbols.....	7	6.22	Disconnecting the USB cable.....	23
2.5	Tampering warning.....	8	6.23	Opening the storage compartment on the left.....	24
2.6	Safe operation	8	6.24	Opening the storage compartment on the right.....	24
2.7	Protective clothing	9	6.25	Closing the storage compartment on the left.....	25
2.8	Work rules.....	9	6.26	Closing the storage compartment on the right.....	25
2.9	Environment.....	9	6.27	Opening fuel tank filler cap.....	25
2.10	Owner's Manual	9	6.28	Closing the fuel tank filler cap.....	26
3	IMPORTANT NOTES.....	11	6.29	Seat lock.....	26
3.1	Manufacturer warranty, implied warranty.....	11	6.30	Tool set.....	27
3.2	Fuel, auxiliary substances.....	11	6.31	Grab handle	27
3.3	Spare parts, technical accessories	11	6.32	Case holders.....	27
3.4	Service	11	6.33	Passenger foot pegs	27
3.5	Figures	11	6.34	Shift lever	28
3.6	Customer service.....	11	6.35	Foot brake lever	28
4	VIEW OF VEHICLE	12	6.36	Side stand.....	28
4.1	View of vehicle, front left (example) ...	12	7	COMBINATION INSTRUMENT	29
4.2	View of vehicle, rear right (example).....	13	7.1	Combination instrument	29
5	SERIAL NUMBERS	14	7.2	Activation and test	30
5.1	Vehicle identification number.....	14	7.3	Warnings.....	30
5.2	Type label	14	7.4	Brake system, temperature warning ...	31
5.3	Key number.....	14	7.5	Ice warning	31
5.4	Engine number	15	7.6	Indicator lamps.....	32
5.5	Fork part number	15	7.7	Display	33
5.6	Shock absorber article number	15	7.8	Track Display (optional)	34
5.7	Steering damper article number	15	7.9	Performance Display (optional).....	35
6	CONTROLS.....	16	7.10	Engine speed.....	36
6.1	Clutch lever.....	16	7.11	Shift warning light	36
6.2	Hand brake lever.....	16	7.12	Cruise control indicator.....	36
6.3	Throttle grip	16	7.13	Speedometer	37
6.4	Combination switch, left side	16	7.14	ABS display.....	37
6.5	Light switch	17	7.15	MTC display	37
6.6	Menu button.....	17	7.16	Damping display	37
6.7	Turn signal switch.....	17	7.17	Load display	38
6.8	Horn button.....	18	7.18	Coolant temperature indicator	38
6.9	Cruise control buttons	18	7.19	Ride-Mode display	38
6.10	+RES/-SET button.....	19	7.20	Gear display	38
6.11	Combination switch, right	20	7.21	Heated grip (optional).....	39
6.12	Start button/emergency OFF switch ...	20	7.22	Seat heating (optional)	39
6.13	Hazard warning flasher switch	20	7.23	Fuel level display	39
6.14	RACE-ON button.....	21	7.24	Favorites display	40
			7.25	Navigation display (optional)	40
			7.26	Call display	40





7.27	Menu.....	41	7.27.54	Units Consumption	62
7.27.1	Bike Info.....	41	7.27.55	Units Pressure.....	62
7.27.2	Bike Info	41	7.27.56	Language.....	62
7.27.3	Trip	42	7.27.57	Settings Heating.....	63
7.27.4	Trip 1	42	7.27.58	Settings Heating Grips	63
7.27.5	Trip 2	42	7.27.59	Settings Heating Rider Seat.....	63
7.27.6	Motorcycle	43	7.27.60	Settings Heating Pillion Seat	63
7.27.7	Ride Mode	43	7.27.61	Extra Functions	64
7.27.8	ABS.....	44	7.27.62	Setting the time and date	64
7.27.9	MTC	44	8	ERGONOMICS	66
7.27.10	MTC+MSR (optional).....	45	8.1	Handlebar position.....	66
7.27.11	Throttle Response (optional)	45	8.2	Adjusting the handlebar position 	66
7.27.12	Slip Adjuster (optional).....	46	8.3	Adjusting the steering angle 	67
7.27.13	Anti Wheelie Mode (optional)	46	8.4	Adjusting the windshield	68
7.27.14	Launch Control (optional)	47	8.5	Adjusting the basic position of the clutch lever	68
7.27.15	Suspension	47	8.6	Adjusting the basic position of the hand brake lever	69
7.27.16	Damping	47	8.7	Adjusting the basic position of the foot brake lever 	69
7.27.17	Load.....	48	8.8	Setting the step plate of the foot brake lever	70
7.27.18	Navigation (optional).....	48	8.9	Checking the basic position of the shift lever.....	70
7.27.19	Last search (optional).....	48	8.10	Adjusting the basic position of the shift lever 	70
7.27.20	Favorites (optional)	49	8.11	Setting the shift lever stub.....	71
7.27.21	Skip Waypoint (optional).....	50	9	PREPARING FOR USE.....	72
7.27.22	Volume (optional)	50	9.1	Advice on preparing for first use	72
7.27.23	Stop Navigation (optional)	51	9.2	Running in the engine	73
7.27.24	Heating (optional).....	51	9.3	Loading the vehicle	73
7.27.25	Heating Grips (optional)	51	10	RIDING INSTRUCTIONS.....	75
7.27.26	Heating Rider Seat (optional).....	52	10.1	Checks and maintenance measures when preparing for use	75
7.27.27	Audio	52	10.2	Starting the vehicle	75
7.27.28	Audio	52	10.3	Launch Control (optional)	77
7.27.29	Settings.....	53	10.4	Starting off.....	77
7.27.30	Custom Switch	53	10.5	Starting off with launch control (optional)	77
7.27.31	C1 and C2 buttons.....	53	10.6	Start off with HHC (Option: Hill-start assist).....	78
7.27.32	Favorites	54	10.7	Anti wheelie mode (optional).....	78
7.27.33	Favorites indicator 1-4	54	10.8	Quickshifter + (optional)	79
7.27.34	Button Illumination.....	54	10.9	Shifting, riding	79
7.27.35	DRL	55	10.10	MSR (optional)	82
7.27.36	KTMconnect.....	55	10.11	Applying the brakes.....	82
7.27.37	Bluetooth.....	56	10.12	Stopping, parking.....	83
7.27.38	Phone.....	56	10.13	Transporting.....	84
7.27.39	Rider's Headset	57	10.14	Towing in the event of a breakdown ...	85
7.27.40	Headset Type	58	10.15	Refueling	85
7.27.41	Quickshifter + (optional).....	58			
7.27.42	Hill Hold Control (optional)	58			
7.27.43	Shift Light	59			
7.27.44	Shift Light State	59			
7.27.45	Shift Light RPM1.....	59			
7.27.46	Shift Light RPM2.....	60			
7.27.47	Cornering Light Test.....	60			
7.27.48	Clock & Date	60			
7.27.49	Clock Format.....	61			
7.27.50	Date Format	61			
7.27.51	Units.....	61			
7.27.52	Units Distance.....	61			
7.27.53	Units Temperature	62			

TABLE OF CONTENTS

11	SERVICE SCHEDULE	87	14.9	Checking the brake linings of the rear brake.....	109
11.1	Additional information.....	87	15	WHEELS, TIRES	111
11.2	Required work	87	15.1	Removing the front wheel 🛠.....	111
11.3	Recommended work.....	88	15.2	Installing the front wheel 🛠.....	112
12	SUSPENSION SETTING.....	89	15.3	Removing the rear wheel 🛠.....	113
12.1	Fork/shock absorber	89	15.4	Installing the rear wheel 🛠.....	114
12.2	"Load".....	89	15.5	Checking the tire condition	115
12.3	"Damping".....	89	15.6	Checking tire pressure	116
13	SERVICE WORK ON THE CHASSIS.....	90	15.7	Using tire repair spray	116
13.1	Raising the motorcycle with the rear lifting gear	90	16	ELECTRICAL SYSTEM	118
13.2	Removing the rear of motorcycle from the lifting gear	90	16.1	Low beam	118
13.3	Lifting the motorcycle with the front lifting gear	90	16.2	High beam	118
13.4	Taking the motorcycle off the front lifting gear	91	16.3	Daytime running light (DRL) (SUPER DUKE GT EU/JP).....	118
13.5	Removing the passenger seat	91	16.4	Cornering light.....	119
13.6	Mounting the passenger seat.....	91	16.5	Socket for electrical accessories	119
13.7	Removing the front rider's seat.....	92	16.6	Removing the 12-V battery 🛠.....	119
13.8	Mounting the front rider's seat.....	92	16.7	Installing the 12-V battery 🛠.....	120
13.9	Removing the windshield.....	92	16.8	Charging the 12-V battery 🛠.....	121
13.10	Installing the windshield.....	93	16.9	Changing the RACE-ON key battery	124
13.11	Removing the main silencer 🛠.....	93	16.10	Changing the main fuse.....	125
13.12	Installing the main silencer 🛠.....	94	16.11	Changing the fuses in the fuse box	126
13.13	Checking the chain for dirt.....	94	16.12	Checking the setting of the lighting system	127
13.14	Cleaning the chain	95	16.13	Adjusting the headlight range.....	129
13.15	Checking the chain tension	95	16.14	Adjusting the cornering light range	129
13.16	Adjusting the chain tension.....	96	16.15	Diagnostics connector	131
13.17	Checking the chain, rear sprocket, engine sprocket, and chain guide	97	16.16	Front ACC1 and ACC2	131
13.18	Checking/correcting the fluid level of the hydraulic clutch	99	16.17	ACC1 and ACC2 rear	131
13.19	Removing the fuel tank spoiler	100	17	COOLING SYSTEM	132
13.20	Installing the fuel tank spoiler.....	101	17.1	Checking the coolant level in the compensating tank.....	132
13.21	Removing front fender	101	17.2	Correcting the coolant level in the compensating tank.....	132
13.22	Installing front fender 🛠.....	101	18	ENGINE TUNING	134
13.23	Cleaning the dust boots of the fork legs 🛠.....	102	18.1	Ride Mode	134
14	BRAKE SYSTEM	103	18.2	Motorcycle traction control (MTC)	134
14.1	Anti-lock braking system (ABS)	103	18.3	Slip adjustment (optional).....	135
14.2	Rear brake temperature monitoring (BTM).....	104	18.4	Throttle Response (optional)	135
14.3	Checking the brake discs	105	19	SERVICE WORK ON THE ENGINE	136
14.4	Checking the front brake fluid level	105	19.1	Checking the engine oil level.....	136
14.5	Adding front brake fluid 🛠.....	106	19.2	Changing the engine oil and oil filter, cleaning the oil screens 🛠.....	136
14.6	Checking the front brake linings	107	19.3	Adding engine oil.....	139
14.7	Checking the rear brake fluid level	108			
14.8	Adding rear brake fluid 🛠.....	108			

20	CLEANING, CARE	141
20.1	Cleaning the motorcycle	141
20.2	Checks and maintenance steps for winter operation	142
21	STORAGE.....	144
21.1	Storage	144
21.2	Preparing for use after storage.....	145
22	TROUBLESHOOTING	146
23	TECHNICAL DATA.....	148
23.1	Engine	148
23.2	Engine tightening torques	149
23.3	Capacities	151
23.3.1	Engine oil	151
23.3.2	Coolant.....	151
23.3.3	Fuel	152
23.4	Chassis	152
23.5	Electrical system.....	153
23.6	Tires	153
23.7	Fork.....	153
23.8	Shock absorber	154
23.9	Chassis tightening torques	154
24	DECLARATIONS OF CONFORMITY	159
24.1	Declarations of conformity	159
24.2	Country-specific declarations of conformity.....	159
24.3	Country-specific declarations of conformity (CCU-2)	160
25	SUBSTANCES	161
26	AUXILIARY SUBSTANCES	163
27	STANDARDS	164
28	INDEX OF SPECIAL TERMS	165
29	LIST OF ABBREVIATIONS.....	166
30	LIST OF SYMBOLS.....	167
30.1	Red symbols.....	167
30.2	Yellow and orange symbols.....	167
30.3	Green and blue symbols.....	167
	INDEX.....	168

1 MEANS OF REPRESENTATION

1.1 Symbols used

The meaning of specific symbols is described below.



Indicates an expected reaction (e.g. of a work step or a function).



Indicates an unexpected reaction (e.g. of a work step or a function).



Indicates work that requires expert knowledge and technical understanding. In the interest of your own safety, have these jobs performed by an authorized KTM workshop! Your motorcycle will be cared for there to the highest degree by specially trained experts using the special tools required.



Indicates a page reference (more information is provided on the specified page).



Indicates information with more details or tips.



Indicates the result of a testing step.



Indicates a voltage measurement.



Indicates a current measurement.



Indicates the end of an activity, including potential rework.

1.2 Formats used

The typographical formats used in this document are explained below.

Proprietary name	Indicates a proprietary name.
Name[®]	Indicates a protected name.
Brand[™]	Indicates a brand available on the open market.
<u>Underlined terms</u>	Refer to technical details of the vehicle or indicate technical terms, which are explained in the glossary.

2.1 Use definition – intended use

The vehicle is designed and constructed to withstand the usual demands of regular traffic and use on race courses. This vehicle is not suitable for offroad use.



Info

This vehicle is only authorized for operation on public roads in its homologated version.

2.2 Misuse

The vehicle must only be used as intended.

Dangers can arise for people, property and the environment through use not as intended.

Any use of the vehicle beyond the intended and defined use constitutes misuse.

Misuse also includes the use of operating and auxiliary fluids which do not meet the required specification for the respective use.

2.3 Safety advice

A number of safety instructions need to be followed to operate the product described safely. Therefore read this instruction and all further instructions included carefully. The safety instructions are highlighted in the text and are referred to at the relevant passages.



Info

Various information and warning labels are attached in prominent locations on the product described. Do not remove any information or warning labels. If they are missing, you or others may not recognize dangers and may therefore be injured.

2.4 Degrees of risk and symbols



Danger

Identifies a danger that will immediately and invariably lead to fatal or serious permanent injury if the appropriate measures are not taken.



Warning

Identifies a danger that is likely to lead to fatal or serious injury if the appropriate measures are not taken.



Caution

Identifies a danger that may lead to minor injuries if the appropriate measures are not taken.

Note

Identifies a danger that will lead to considerable machine and material damage if the appropriate measures are not taken.



Note

Indicates a danger that will lead to environmental damage if the appropriate measures are not taken.

2.5 Tampering warning

Tampering with the noise control system is prohibited. Federal law prohibits the following acts or the causing thereof:

- 1 The removal or rendering inoperative by any person other than for purposes of servicing, repair, or replacement, of any device or element of design incorporated into any new vehicle for the purpose of noise control prior to its sale or delivery to the ultimate purchaser or while it is in use, or
- 2 the use of the vehicle after such device or element of design has been removed or rendered inoperative by any person.

Among those acts presumed to constitute tampering are the acts listed below:

- 1 Removal or puncturing of the main silencers, baffles, header pipes or any other components which conduct exhaust gases.
- 2 Removal or puncturing of parts of the intake system.
- 3 Lack of proper maintenance.
- 4 Replacing moving parts of the vehicle, or parts of the exhaust system or intake system, with parts other than those specified by the manufacturer.

2.6 Safe operation



Danger

Danger of accidents A rider who is not fit to ride poses a danger to him or herself and others.

- Do not operate the vehicle if you are not fit to ride due to alcohol, drugs or medication.
- Do not operate the vehicle if you are physically or mentally impaired.



Danger

Danger of poisoning Exhaust gases are toxic and inhaling them may result in unconsciousness and death.

- Always make sure there is sufficient ventilation when running the engine.
- Use effective exhaust extraction when starting or running the engine in an enclosed space.



Warning

Danger of burns Some vehicle components become very hot when the vehicle is operated.

- Do not touch any parts such as the exhaust system, radiator, engine, shock absorber, or brake system before the vehicle parts have cooled down.
- Let the vehicle parts cool down before you perform any work on the vehicle.

Only operate the vehicle when it is in perfect technical condition, in accordance with its intended use, and in a safe and environmentally compatible manner.

The vehicle should only be used by trained persons. An appropriate driver's license is needed to ride the vehicle on public roads.

Have malfunctions that impair safety promptly eliminated by an authorized KTM workshop.

Adhere to the information and warning labels on the vehicle.

2.7 Protective clothing



Warning

Risk of injury Missing or poor protective clothing presents an increased safety risk.

- Wear appropriate protective clothing such as helmet, boots, gloves as well as trousers and a jacket with protectors on all rides.
- Always wear protective clothing that is in good condition and meets the legal regulations.

In the interest of your own safety, KTM recommends that you only operate the vehicle while wearing protective clothing.

2.8 Work rules

Unless specified otherwise, the ignition must be turned off during all work (models with ignition lock, models with remote key) or the engine must be at a standstill (models without ignition lock or remote key).

Special tools are necessary for certain tasks. The tools are not a component of the vehicle, but can be ordered using the number in parentheses. Example: bearing puller (15112017000)

Unless otherwise noted, normal conditions apply to all tasks and descriptions.

Ambient temperature	20 °C (68 °F)
Ambient air pressure	1,013 mbar (14.69 psi)
Relative air humidity	60 ± 5 %

During assembly, use new parts to replace parts which cannot be reused (e.g. self-locking screws and nuts, expansion screws, seals, sealing rings, O-rings, pins, and lock washers).

In the case of certain screws, a screw adhesive (e.g. **Loctite**®) is required. Observe the manufacturer's instructions.

If thread locker (e.g., **Precote**®) has already been applied to a new part, do not apply any additional thread locker. After disassembly, clean the parts that are to be reused and check them for damage and wear. Change damaged or worn parts.

After completing a repair or service work, check the operating safety of the vehicle.

2.9 Environment

If you use your motorcycle responsibly, you can ensure that problems and conflicts do not occur. To protect the future of the motorcycle sport, make sure that you use your motorcycle legally, display environmental consciousness, and respect the rights of others.

When disposing of used oil, other operating and auxiliary fluids, and used components, comply with the laws and regulations of the respective country.

Because motorcycles are not subject to the EU regulations governing the disposal of used vehicles, there are no legal regulations that pertain to the disposal of an end-of-life motorcycle. Your authorized KTM dealer will be glad to advise you.

2.10 Owner's Manual

Read this owner's manual carefully and completely before making your first trip. The Owner's Manual contains useful information and many tips on how to operate, handle, and service your motorcycle. This is the only way to find out how best to customize the vehicle for your own use and how you can protect yourself from injury.



Tip

Store the Owner's Manual on your terminal device, for example, so that you can read it whenever you need to.

If you would like to know more about the vehicle or have questions on the material you read, please contact an authorized KTM dealer.

2 SAFETY ADVICE

The Owner's Manual is an important component of the vehicle. If the vehicle is sold, the Owner's Manual must be downloaded again by the new owner.

The Owner's Manual can be downloaded several times using the QR code or the link on the delivery certificate.

The Owner's Manual is also available for download from your authorized KTM dealer and on the KTM website. A printed copy can also be ordered from your authorized KTM dealer.

International KTM Website: KTM.COM

3.1 Manufacturer warranty, implied warranty

The work prescribed in the service schedule must only be carried out in an authorized KTM workshop and confirmed in the **KTM Dealer.net**, as otherwise all warranty claims will be void. Damage or secondary damage caused by tampering with and/or conversions on the vehicle are not covered by the manufacturer warranty.

3.2 Fuel, auxiliary substances



Note

Environmental hazard Improper handling of fuel is a danger to the environment.

- Do not allow fuel to enter the groundwater, the soil, or the sewage system.

Use fuels and auxiliary substances in accordance with the Owner's Manual and specification.

3.3 Spare parts, technical accessories

For your own safety, only use spare parts and accessory products that are approved and/or recommended by KTM and have them installed by an authorized KTM workshop. KTM accepts no liability for other products and any resulting damage or loss.

Certain spare parts and accessory products are specified in parentheses in the descriptions. Your authorized KTM dealer will be glad to advise you.

The latest news **KTM PowerParts** on your vehicle can be found on the KTM website.

International KTM Website: KTM.COM

3.4 Service

A prerequisite for perfect operation and prevention of premature wear is that the service, care, and tuning work on the engine and chassis is properly carried out as described in the Owner's Manual. An incorrect suspension setting can lead to damage and breakage of chassis components.

Use of the vehicle under difficult conditions, such as dusty environments, heavy rain, high heat or with a heavy load, can lead to considerably more rapid wear of components such as the air filter, drive train, brake system, or suspension components. For this reason, it may be necessary to inspect or replace parts before the next scheduled service.

It is imperative that you adhere to the stipulated run-in times and service intervals. If you observe these exactly, you will ensure a much longer service life for your motorcycle.

The relevant mileage or time interval is whichever occurs first.

3.5 Figures

The figures contained in the manual may depict special equipment.

In the interest of clarity, some components may be shown disassembled or may not be shown at all. It is not always necessary to disassemble the component to perform the activity in question. Please follow the instructions in the text.

3.6 Customer service

Your authorized KTM dealer will be happy to answer any questions you may have on your vehicle and KTM.

A list of authorized KTM dealers can be found on the KTM website.

International KTM Website: KTM.COM

4 VIEW OF VEHICLE

4.1 View of vehicle, front left (example)

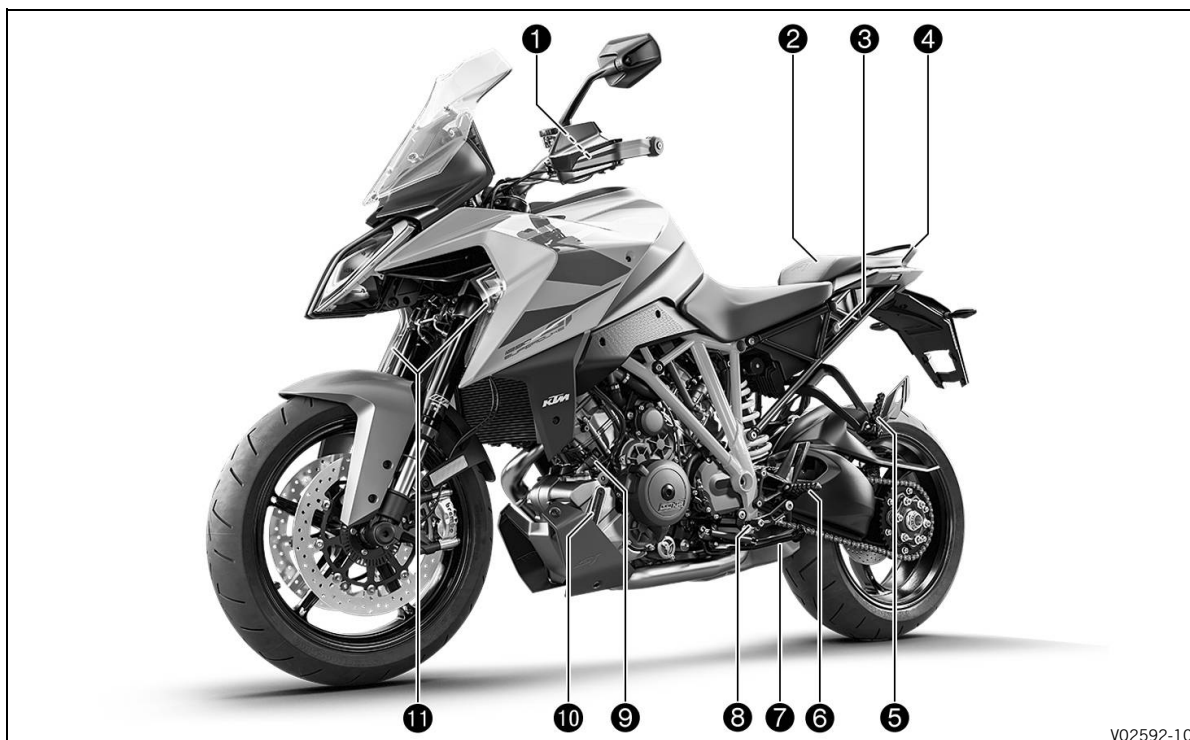

- ❶ Clutch lever (📖 p. 16)
- ❷ Passenger seat
- ❸ Seat lock (📖 p. 26)
- ❹ Grab handle (📖 p. 27)
- ❺ Passenger foot pegs (📖 p. 27)
- ❻ Rider footrests
- ❼ Side stand (📖 p. 28)
- ❽ Shift lever (📖 p. 28)
- ❾ Engine oil filler neck
- ❿ Level viewer, engine oil
- ⓫ Cornering light (📖 p. 119)

4.2 View of vehicle, rear right (example)

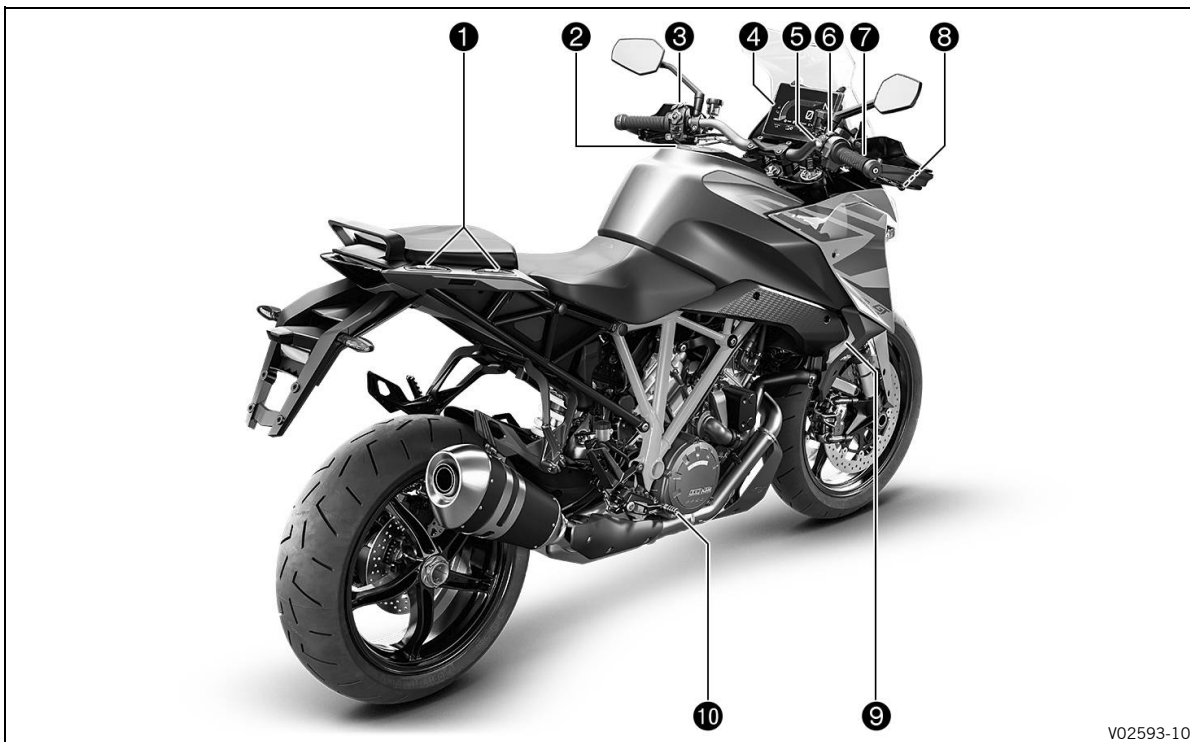

V02593-10

- ① Case holders (📖 p. 27)
- ② Fuel tank filler cap
- ③ Combination switch, left side (📖 p. 16)
- ④ Combination instrument (📖 p. 29)
- ⑤ Start button/emergency OFF switch (📖 p. 20)
- ⑥ RACE-ON button (📖 p. 21)
- ⑦ Throttle grip (📖 p. 16)
- ⑧ Hand brake lever (📖 p. 16)
- ⑨ Cooling system compensating tank
- ⑩ Foot brake lever (📖 p. 28)

5.1 Vehicle identification number

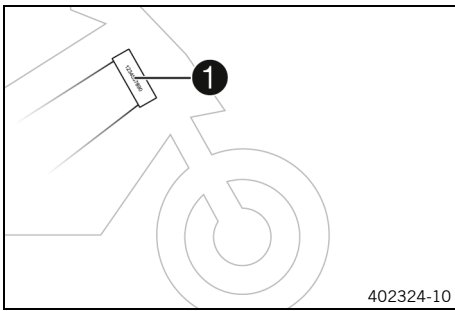

The vehicle identification number **1** is stamped on the right side of the steering head.
The vehicle identification number is also shown on the type label.

5.2 Type label

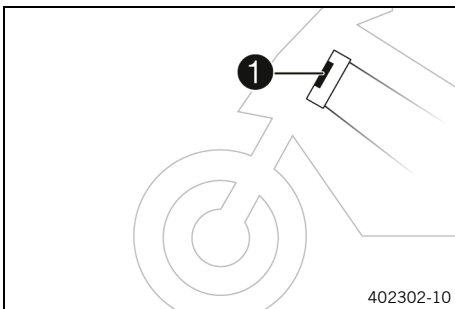

(SUPER DUKE GT EU/JP)

The type label **1** is located on the steering head.

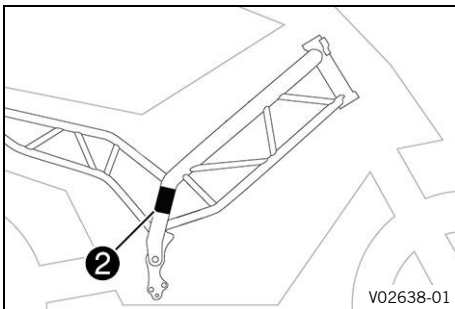

(SUPER DUKE GT CN)

The China type label **2** is located on the frame on the right.

5.3 Key number

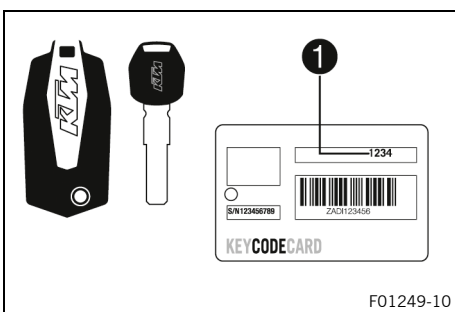

The key number **Code number 1** can be found on the **KEYCODECARD**.



Info

You need the key number to order a spare key. Keep the **KEYCODECARD** in a safe place.

5.4 Engine number

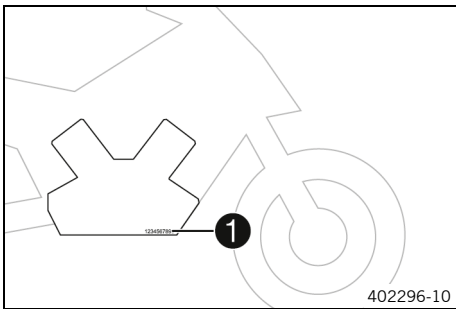

The engine number **1** is stamped on the right side of the engine.

5.5 Fork part number

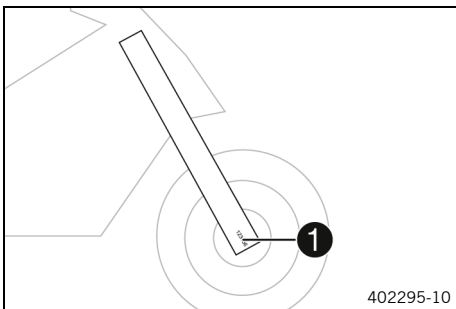

The fork part number **1** is stamped on the inside of the axle clamp.

5.6 Shock absorber article number

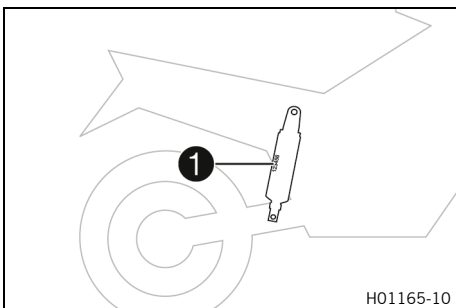

The shock absorber article number **1** is printed on a sticker on the shock absorber case under the spring.

5.7 Steering damper article number

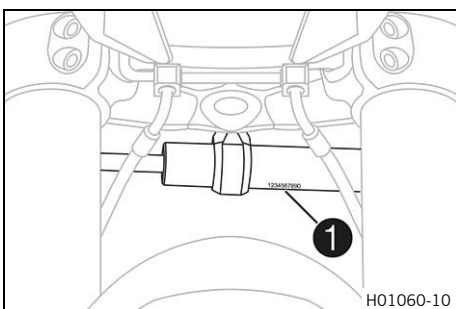

Steering damper item number **1** is embossed on the underside of the steering damper.

6.1 Clutch lever

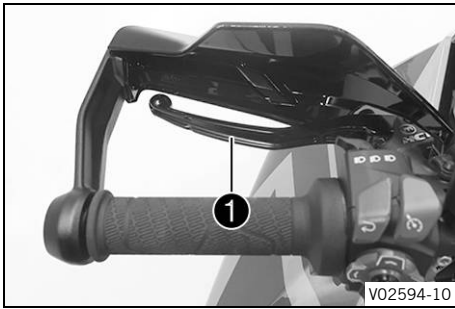

Clutch lever **1** is fitted on the handlebar on the left. The clutch is activated hydraulically and adjusts itself automatically.

6.2 Hand brake lever

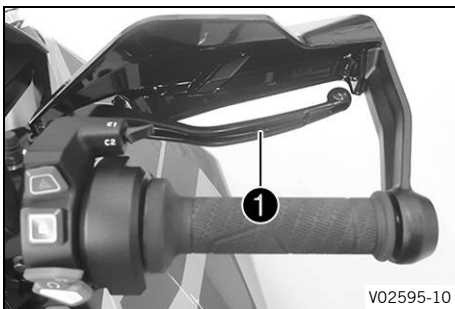

The hand brake lever **1** is located on the right side of the handlebar. The front brake is engaged using the hand brake lever.

6.3 Throttle grip

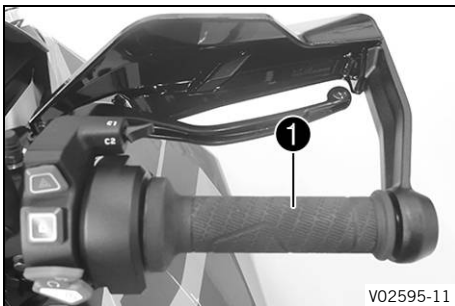

The throttle grip **1** is fitted on the right side of the handlebar.

6.4 Combination switch, left side

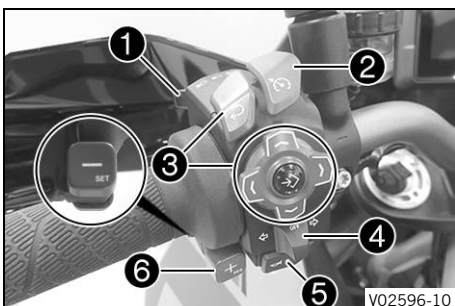

The left combination switch is fitted on the left side of the handlebar.

Overview of the left combination switch

- 1** Light switch (📖 p. 17)
- 2** Cruise control buttons (📖 p. 18)
- 3** Menu button (📖 p. 17)
- 4** Turn signal switch (📖 p. 17)
- 5** Horn button (📖 p. 18)
- 6** +RES/-SET button (📖 p. 19)

6.5 Light switch

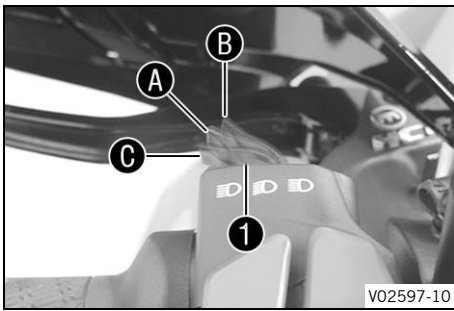

The light switch ① is fitted on the combination switch on the left.

Possible states

	Low beam on – Light switch in position ①. In this position, the low beam and the tail light are switched on.
	High beam on – Light switch in position ②. In this position, the high beam and the tail light are switched on.
	Headlight flasher – Light switch in position ③. The headlight flasher is operated in this position. The light switch returns automatically to the position ① after use.

6.6 Menu button

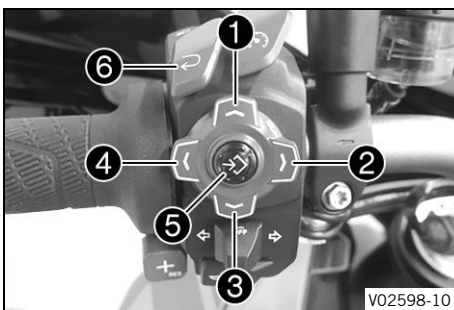

The menu buttons are fitted in the middle of the left combination switch.

The menu buttons are used to control the matrix display on the combination instrument.

- Button ① is the **UP** button.
- Button ② is the **RIGHT** button.
- Button ③ is the **DOWN** button.
- Button ④ is the **LEFT** button.
- Button ⑤ is the **SET** button.
- Button ⑥ is the **BACK** button.

6.7 Turn signal switch

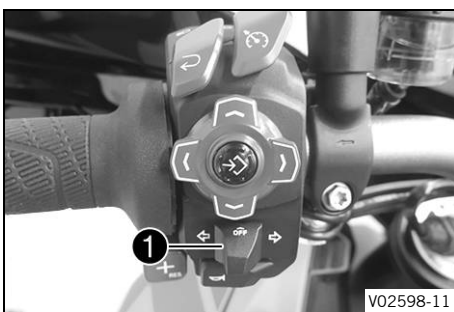

Turn signal switch ① is fitted on the combination switch on the left.

Possible states

	Turn signal off – Push the turn signal switch toward the switch housing.
	Left turn signal, on – Turn signal switch pressed to the left. The turn signal switch returns automatically to the central position after use.
	Right turn signal, on – Turn signal switch pressed to the right. The turn signal switch returns automatically to the central position after use.

i Info

An automatic turn signal switch-off function (**ATIR**) is available as a software feature.

The **ATIR** function uses a time and distance counter.

If the turn signal has been on for at least 10 seconds and 150 meters of riding distance, the turn signal is switched off.

If the vehicle is stationary, both counters are stopped.

If the turn signal switch is reactivated, both counters are reset.

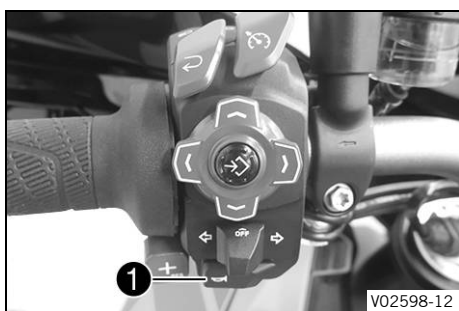
6.8 Horn button

Horn button **1** is fitted on the left side of the handlebar.

Possible states

- The horn button **1** is in the basic position
- The horn button **1** is pressed – The horn is operated in this position.

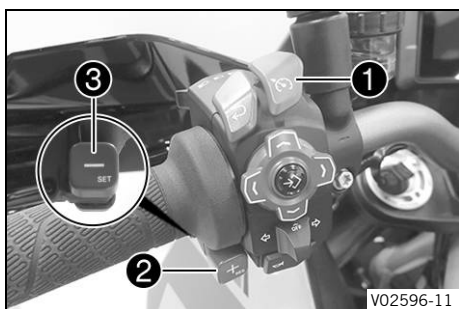
6.9 Cruise control buttons

The cruise control buttons **1**, **2** and **3** of the are located on the left side of the combination switch.

Possible states

- Cruise control system button **1** in the basic position.
- The **+RES** button is pressed briefly. – The last saved speed is reapplied. Every subsequent brief pressing increases the target speed by 1 km/h or 1 mph.
- Button **+RES** is pressed and held. – The target speed increases in increments of 5 km/h or 5 mph.
- Button **-SET** is pressed. – The cruise control function is activated and the current speed is maintained. Every subsequent brief press reduces the target speed by 1 km/h or 1 mph.
- Button **-SET** is pressed and held. – The target speed decreases in increments of 5 km/h or 5 mph.

i Info

After activating the cruise control function, the throttle grip can be turned back to the basic position. The selected speed will be maintained.

If no target speed has yet been saved, this can be saved once using the **+RES** button.

If the cruise speed is exceeded for less than 30 seconds by turning the throttle grip, the cruise control remains activated.

To switch off the cruise control system function press the cruise control system button again.

In addition, the cruise control system function is deactivated when one of the following events occurs:

- Operating the hand brake lever
- Operating the foot brake lever
- Operating the clutch lever
- Gear change without quickshifter+
- Turning the throttle grip beyond the basic position
- Control of the motorcycle traction control (**MTC**)
- Slip at the rear wheel or lifting front wheel
- A fault occurring, which impairs the cruise control system function
- Exceeding the target speed for more than 30 seconds when overtaking



Warning

Danger of accidents The cruise control system function is not suitable for all riding situations.

The selected target speed will not be reached, if the engine power is not sufficient for a gradient.
The selected target speed will be exceeded if the engine braking effect is not sufficient on an incline.

- Do not use the cruise control systems function on winding roads.
- Do not use the cruise control systems on slippery road surfaces (e.g. rain, ice or snow), where there is poor visibility or on unpaved surfaces (e.g. sand, stones or gravel).
- Do not use the cruise control systems function if the traffic does not permit a constant speed.

The cruise control system function is only available when motorcycle traction control (**MTC**) is activated.

When motorcycle traction control (**MTC**) is switched off, the cruise control system function is also switched off.

The cruise control system function cannot be activated during rapid acceleration.

The cruise control system function can only be activated in third, fourth, fifth and sixth-gear.

The control range is from 40 to 200 km/h or from 25 to 125 mph.

6.10 +RES/-SET button

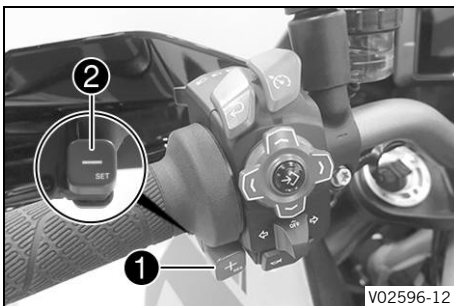

The **+RES** button **1** is fitted on the front left of the handlebar.

The **-SET** button **2** is fitted on the rear left of the handlebar.



Info

The **+RES** and **-SET** buttons are used to control the cruise control when the cruise control function is activated.

If the cruise control function is deactivated, the **+RES** and **-SET** buttons in the main display or in the **Slip Adjuster** menu can be used to adjust the **Slip Adjuster**.

6.11 Combination switch, right

The right combination switch is fitted on the right side of the handlebar.

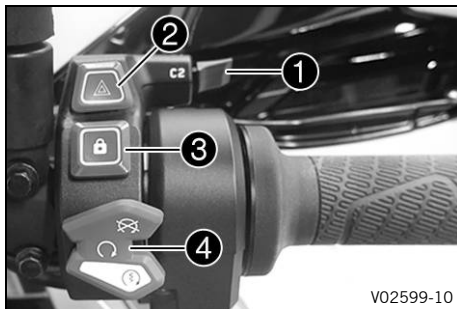

Overview of the right combination switch

- ❶ C1 and C2 switch (📖 p. 21)
- ❷ Hazard warning flasher switch (📖 p. 20)
- ❸ RACE-ON button (📖 p. 21)
- ❹ Start button/emergency OFF switch (📖 p. 20)

6.12 Start button/emergency OFF switch

The start button/emergency OFF switch ❶ is fitted on the right side of the combination switch.



Possible states

	Start button/emergency OFF switch off (upper position) – In this position, the ignition circuit is interrupted, a running engine stops, and cannot be started. A message appears on the display.
	Start button/emergency OFF switch on (middle position) – This position is required for operation; the ignition circuit is closed.
	Starter motor on (lower position) – In this position, the starter motor is actuated.

6.13 Hazard warning flasher switch

The hazard warning flasher switch ❶ is fitted on the right side of the combination switch.

The hazard warning flasher is used to indicate emergency situations.



i Info

The hazard warning flasher can be activated or deactivated while the ignition is switched on or up to 60 seconds after the ignition is switched off.

Only keep the hazard warning flasher activated as long as necessary as it depletes the 12-V battery.

Possible states

	Hazard warning flasher on – All four turn signals and the green turn signal indicator lights in the combination instrument flash.
--	---

6.14 RACE-ON button



The RACE-ON button ① is fitted on the right side of the combination switch.

i Info

The RACE-ON button performs the ignition lock function on this vehicle. The steering can only be locked if the handlebar is turned to the left.

Possible states

- RACE-ON button ① in the basic position.
- RACE-ON button ① pressed briefly – Pressing briefly switches the ignition on and unlocks the steering lock or switches the ignition off. The RACE-ON indicator lamp lights up briefly once for confirmation.
- RACE-ON button ① pressed and held – Pressing and holding switches the ignition off and locks the steering lock.

6.15 C1 and C2 switch

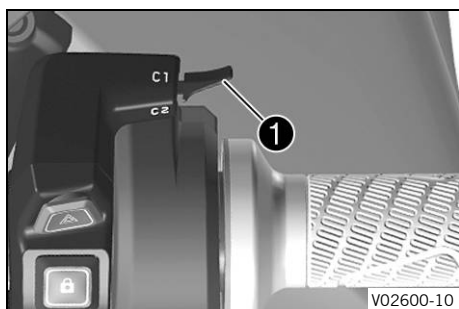

The C1 and C2 switch is fitted on the right of the combination switch.

i Info

The C1 and C2 switch enables quick access to various menus. The C1 and C2 switch can be freely configured.

6.16 RACE-ON key

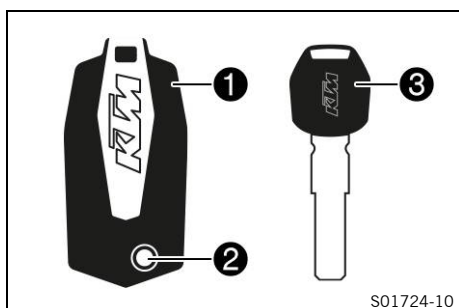

In this vehicle, the RACE-ON key ① performs all the functions of the conventional ignition key.

Press the ② button to fold out the key bit. The key bit is only used for unlocking the seat lock and for opening the cases (optional).

The black ignition key ③ is only intended for situations in which the RACE-ON key is not available or is not functional.

The black ignition key can be used to start the vehicle if the RACE-ON key battery voltage is too low and the transponder is not recognized by the vehicle. The black Race-on key can also be used to unlock the seat lock and open the cases (optional).

i Info

The ignition keys contain electronic components. Always maintain a distance of several centimeters to other devices with electronic components.

A lost ignition key must be deactivated by an authorized KTM workshop to prevent unauthorized persons from operating the vehicle.

The ignition keys supplied are activated when delivered.

Up to four ignition keys in total can be activated by an authorized KTM workshop. The key number must be provided in each case.

6.17 Steering lock (antenna)

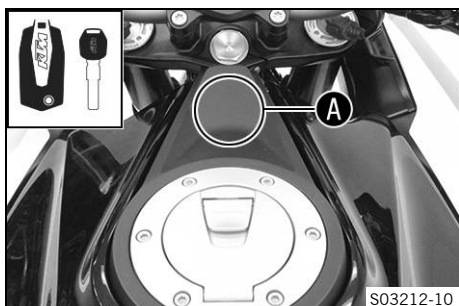

On this vehicle, the ignition/steering lock is replaced by a remote key with transponder (RACE-ON key (🔑 p. 21)).

In order to activate the steering lock, the handlebar must be turned fully to the left.

The steering is locked and unlocked electromechanically via the RACE-ON button (🔑 p. 21).

If the battery voltage of the RACE-ON key is too low, place either the RACE-ON key or the black ignition key in area **A** and repeat starting.

i Info

Store the ignition key safely again as soon as the engine has been started.

Possible states

- Ignition off, steering locked – In this operating mode, the ignition circuit is interrupted and the steering locked.
- Ignition off, steering unlocked – In this operating mode, the ignition circuit is interrupted and the steering unlocked.
- Ignition on, steering unlocked – In this operating mode, the ignition circuit is closed and the steering unlocked.

6.18 Immobilizer



The electronic immobilizer secures the vehicle against unauthorized use.

The immobilizer is activated and the engine electronics are locked as soon as the ignition is switched off via the RACE-ON button (🔑 p. 21).

The RACE-ON indicator lamp **1** can indicate errors by flashing. If the optional alarm system is installed, the RACE-ON indicator lamp **1** flashes when the ignition is switched off and the alarm system is switched on.

6.19 Socket for electrical accessories



Socket **1** for electrical accessories is mounted on the left side of the instrument support.

It is connected to the permanent positive and is fuse-protected.

Socket for electrical accessories	
Voltage	12 V
Maximum current consumption	10 A

6.20 USB socket

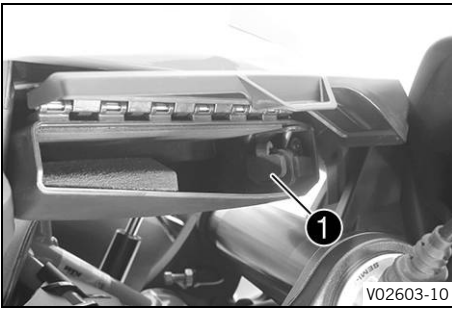

A USB socket ❶ for supplying power to external devices is located in the left storage compartment. The USB socket is activated when the ignition is switched on.

USB socket	
Voltage	5 V
Maximum current consumption	2.1 A

6.21 Connecting the USB cable

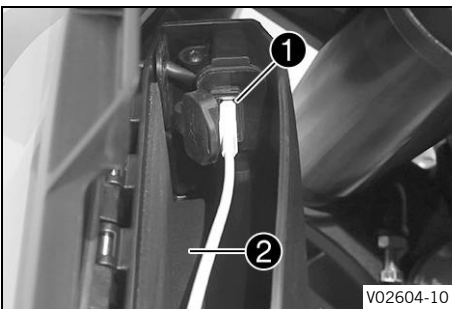

Preliminary work

- Open storage compartment on the left. (🔧 p. 24)

Main work

- Connect a suitable USB cable to the USB socket ❶.
- Connect USB cable to the device and stow in the ❷ storage compartment.



Info

Depending on the size of the device, an angled plug is advantageous. Always secure stowed objects additionally against moisture. Stow cables so that no damage can result.

Final steps

- Close storage compartment on the left. (🔧 p. 25)



6.22 Disconnecting the USB cable

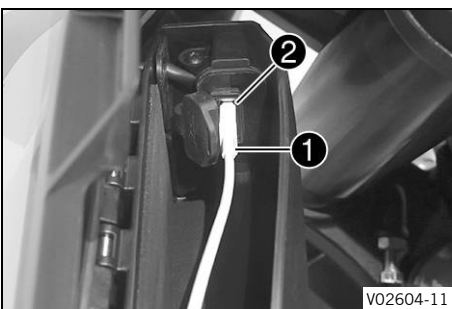

Preliminary work

- Open storage compartment on the left. (🔧 p. 24)

Main work

- Disconnect USB cable ❶ from the device.
- Disconnect USB cable from the USB socket ❷.

Final steps

- Close storage compartment on the left. (🔧 p. 25)



6.23 Opening the storage compartment on the left

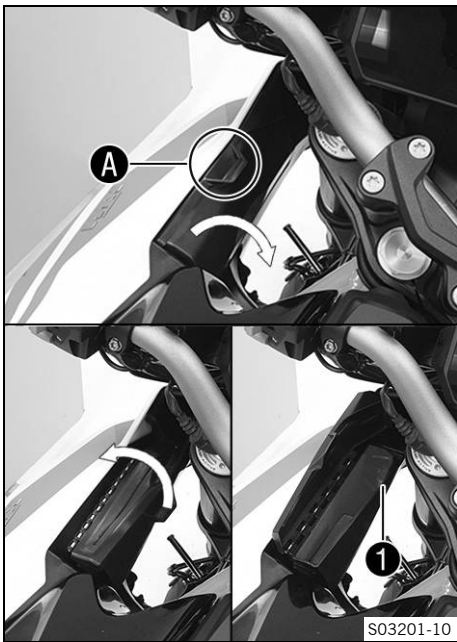

- Turn handlebar as far as possible to the right.
- Fold out storage compartment in area **A** toward the fork leg.
- Open storage compartment.

i **Info**

A USB socket (📖 p. 23) **1** is located in the storage compartment for supplying power to external devices. The storage compartment must be closed before going on a ride.

6.24 Opening the storage compartment on the right

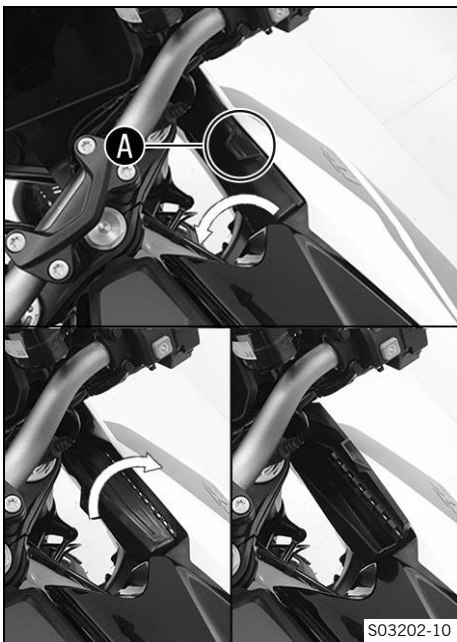

- Turn handlebar all the way to the left.
- Fold out storage compartment in area **A** toward the fork leg.
- Open storage compartment.

i **Info**

The storage compartment must be closed before going on a ride.

6.25 Closing the storage compartment on the left



- Close storage compartment.
- Fold down storage compartment.



Info

With the handlebar turned all the way to the left and with locked steering, the storage compartment is hard to access, however the storage compartment is not lockable.



6.26 Closing the storage compartment on the right



- Close storage compartment.
- Fold down storage compartment.



Info

The storage compartment is not lockable.



6.27 Opening fuel tank filler cap



Danger

Fire hazard Fuel is highly flammable.

The fuel in the fuel tank expands when warm and can escape if overfilled.

- Do not fuel the vehicle in the vicinity of open flames or lit cigarettes.
- Switch off the engine for refueling.
- Make sure that no fuel is spilled; particularly not on hot parts of the vehicle.
- If any fuel is spilled, wipe it off immediately.
- Observe the specifications for refueling.



Warning

Danger of poisoning Fuel is poisonous and a health hazard.

- Avoid skin, eye and clothing contact with fuel.
- Immediately consult a doctor if you swallow fuel.
- Do not inhale fuel vapors.
- In case of skin contact, rinse the affected area with plenty of water.
- Rinse the eyes thoroughly with water, and consult a doctor in case of fuel contact with the eyes.
- Change your clothing in case of fuel spills on them.
- Keep fuels correctly in a suitable canister, and out of the reach of children.



Note

Environmental hazard Improper handling of fuel is a danger to the environment.

- Do not allow fuel to enter the groundwater, the soil, or the sewage system.

Condition

The motorcycle is stationary.

The engine is switched off.

The ignition has been switched on or off for less than 1 minute.

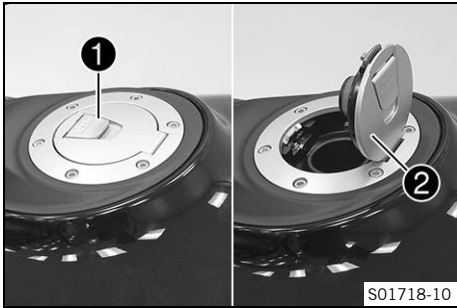

- Fold up cover **1** slowly.
- ✓ The fuel tank filler cap is unlocked.
- Fold up fuel tank filler cap **2**.

6.28 Closing the fuel tank filler cap

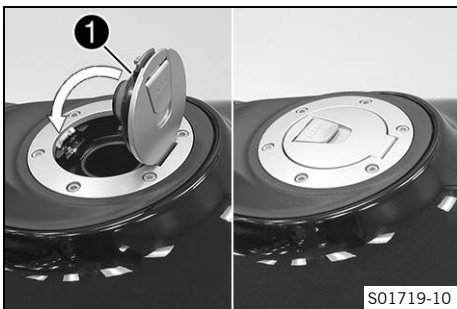

Warning

Fire hazard Fuel is highly flammable, toxic and a health hazard.

- Check that the fuel tank filler cap is locked correctly after closing.
- Change your clothing if fuel spills on them.
- Rinse the affected area immediately with plenty of water in the event of contact with the skin.

- Fold down fuel tank filler cap **1** and push it down.
- ✓ The fuel tank filler cap locks audibly in place.

6.29 Seat lock

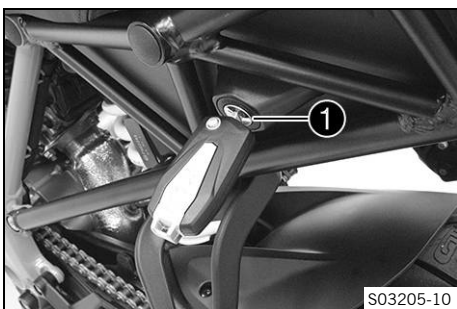

Seat lock **1** is located on the left side of the vehicle under the seat.

It can be unlocked using the RACE-ON key or the black ignition key.

6.30 Tool set

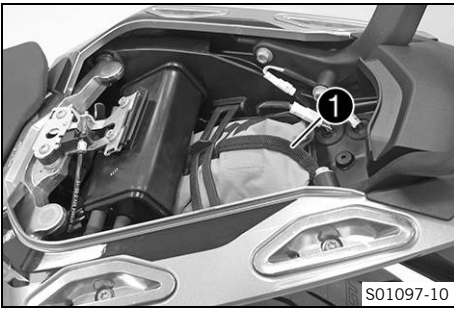

The storage compartment under the passenger seat contains tool set ❶.

6.31 Grab handle

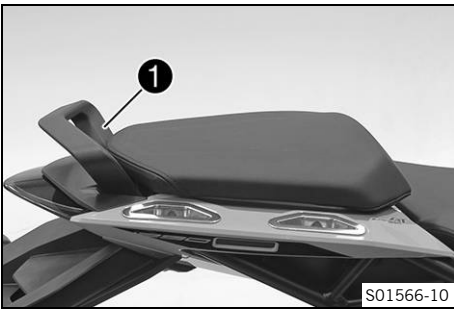

The passenger can hold onto the grab handle ❶ during the trip.

6.32 Case holders

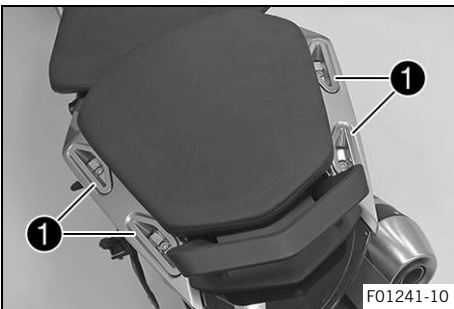

Case holders ❶ are located on each side of the passenger seat. A case system (optional) can be attached on the case holders. The case holders may not be loaded with more than the specified weight.

Maximum permissible load of the case holders per side	7 kg (15 lb.)
---	---------------

i Info
Follow the instructions provided by the luggage manufacturer.

6.33 Passenger foot pegs

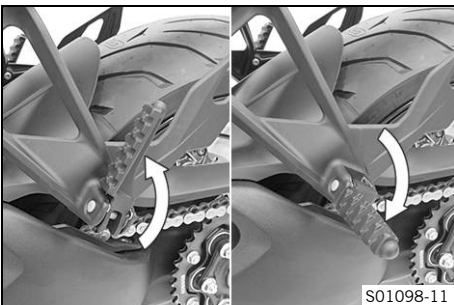

The passenger foot pegs can be folded up and down.

Possible states

- Passenger foot pegs folded up – For operation without a passenger.
- Passenger foot pegs folded down – For operation with a passenger.

6.34 Shift lever

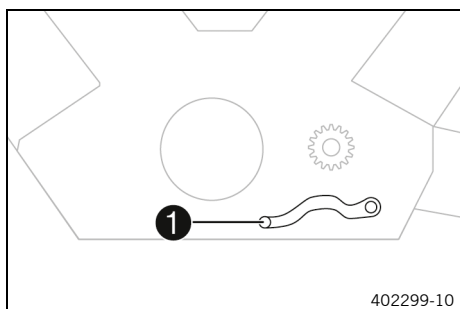

The shift lever ❶ is fitted on the left side of the engine.

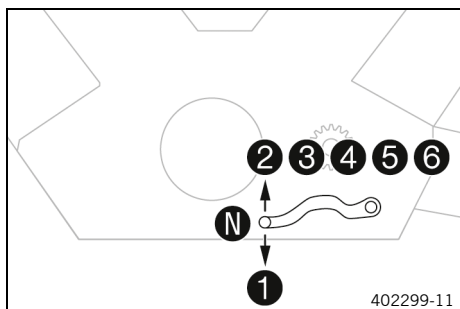

The gear positions can be seen in the figure.
The idle position is between first and second gears.

6.35 Foot brake lever

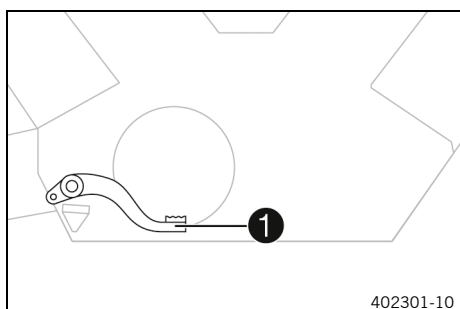

Foot brake lever ❶ is located in front of the right footrest.
The rear brake is engaged with the foot brake lever.

6.36 Side stand

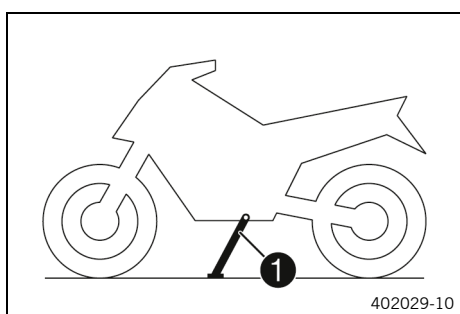

Side stand ❶ is located on the left of the vehicle.
The side stand is used for parking the motorcycle.

i Info

The side stand must be folded up during motorcycle use.
The side stand is coupled with the safety starting system; see the instructions in the "Stopping, parking" chapter.

Possible states

- Side stand folded out – The vehicle can be supported on the side stand. The safety starting system is active.
- Side stand folded in – This position is mandatory when riding the motorcycle. The safety starting system is inactive.

7.1 Combination instrument



V02258-01

The combination instrument is attached in front of the handlebar.
The combination instrument is divided into two function areas.

① indicator lamps (p. 32)

Display ②

**Warning**

Danger of burns Parts of the combination instrument become very hot in certain situations.

In particular, the display gets hot in ambient temperatures above 55 °C (131 °F), during extended stationary periods, for example, at a traffic light, or in direct sunlight.

- Do not touch the combination instrument with bare hands in the situations referred to.
- Where appropriate protective clothing.
- If you have been burned, hold the area affected under lukewarm water immediately.

**Info**

The inclination of the combination instrument cannot be set.

7.2 Activation and test



Activation

The combination instrument is activated when the ignition is switched on.

i Info

The brightness of the displays is controlled by an ambient light sensor in the combination instrument.

Test

The welcome text appears on the display and the indicator lamps are briefly activated for a function check.

i Info

The malfunction indicator lamp always lights up as long as the engine is not running. If the engine is running and the malfunction indicator lamp lights up, stop (taking care not to endanger yourself or other road users in the process) and contact an authorized KTM workshop.

The oil pressure warning lamp always lights up as long as the engine is not running. If the engine is running and the oil pressure warning lamp lights up, stop immediately (taking care not to endanger yourself or other road users in the process) and switch off the engine.

The ABS warning lamp and TC indicator lamp light up until a speed of approx. 6 km/h (approx. 4 mph) or more has been reached.

7.3 Warnings

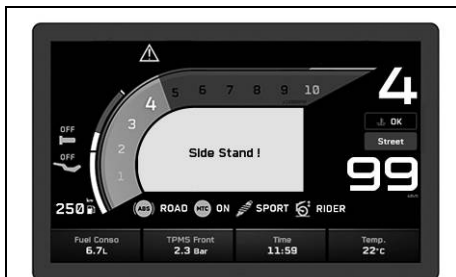

Warnings appear in the middle of the display; these are marked yellow or red depending on their relevance.

Yellow warnings indicate malfunctions or information which require prompt intervention or an adjustment to the riding style. Red warnings indicate malfunctions or information which require immediate intervention.

i Info

Warnings can be hidden by pressing any button.

All the existing warnings are displayed in the **Warnings** menu until they are no longer active.



7.4 Brake system, temperature warning

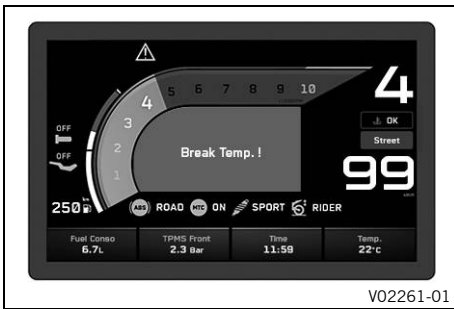

When the rear brake is used frequently and for excessively long periods, for example on long downhill stretches, the temperature of the brake system may increase.

The warning is displayed in the center of the display. Combined use of the rear and front brake is recommended.



Warning

Danger of accidents The brake temperature monitoring does not protect from overheating.

The brake temperature is calculated, not measured.

- See instructions in the "Braking" chapter.
- Stop immediately, even if no temperature warning is displayed, if the brake lever pressure point becomes spongy.

7.5 Ice warning



The ice warning ❄ goes on when there is an increased risk of ice on the roads.

The ice warning ❄ appears in the middle of the display and is highlighted in yellow.

The ice warning ❄ appears on the display when the ambient temperature drops below the specified value.

Temperature	$\leq 4 \text{ }^{\circ}\text{C}$ ($\leq 39 \text{ }^{\circ}\text{F}$)
-------------	--

The ice warning ❄ goes out on the display when the ambient temperature rises above the specified value again.

Temperature	$\geq 6 \text{ }^{\circ}\text{C}$ ($\geq 43 \text{ }^{\circ}\text{F}$)
-------------	--



Info

When the ice warning ❄ lights up, the warning **ICE WARNING** also appears.

7.6 Indicator lamps



V02256-01

The indicator lamps offer additional information about the operating state of the motorcycle. When the ignition is switched on, all indicator lamps light up briefly.

i Info









The malfunction indicator lamp always lights up as long as the engine is not running. If the engine is running and the malfunction indicator lamp lights up, stop (taking care not to endanger yourself or other road users in the process) and contact an authorized KTM workshop.

The oil pressure warning lamp always lights up as long as the engine is not running. If the engine is running and the oil pressure warning lamp lights up, stop immediately (taking care not to endanger yourself or other road users in the process) and switch off the engine.

The ABS warning lamp and TC indicator lamp light up until a speed of approx. 6 km/h (approx. 4 mph) or more has been reached.

Possible states

	RACE-ON indicator lamp lights up/flashes yellow/orange/red – Status or error messages relating to Race-on system/alarm system.
	The left turn signal indicator lamp flashes green with a steady rhythm – The left turn signal is switched on.
	The oil pressure warning lamp lights up red – The oil pressure is too low. Stop immediately, taking care not to endanger yourself or other road users in the process, and switch off the engine.
	The general warning lamp lights up yellow – A note/warning note on operating safety has been detected. This is also shown in the display.
	The malfunction indicator lamp lights up yellow – The <u>OBD</u> has detected a malfunction in the vehicle electronics.

	TC indicator lamp lights up/flashes yellow – The MTC (p. 134) is not enabled or is currently intervening. The TC indicator lamp also lights up if a malfunction is detected. Contact an authorized KTM workshop. The TC indicator lamp flashes if the motorcycle traction control actively engages or if the HHC (p. 78) (optional) is activated.
	The cruise control system indicator lamp lights up yellow – The cruise control system function is switched on, but cruise control is not activated.
	The cruise control system indicator lamp lights up green – The cruise control system function is switched on and cruise control is activated.
	The ABS warning lamp lights up yellow – Status or error messages relating to ABS . The ABS warning lamp flashes if the ABS mode Supersmoto is enabled.
	Ice warning is active in the display – The warning lamp lights up when there is increased risk of icy roads.
	The high beam indicator lamp lights up blue – The high beam is switched on.
	The right turn signal indicator lamp flashes green with a steady rhythmic flash – The right turn signal is switched on.
	The idle indicator lamp lights up green – The transmission is in the neutral position.

7.7 Display

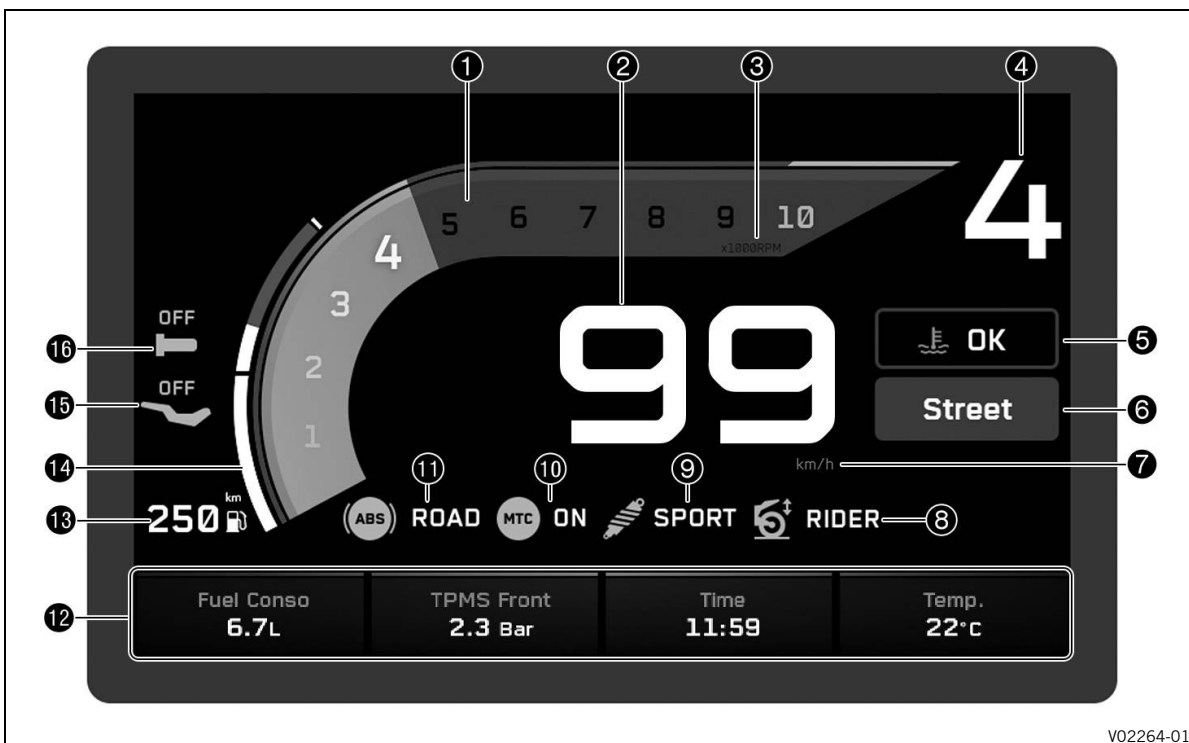

V02264-01

i Info

The figure shows the start screen of the combination instrument. If the menu is open, the speed and the selected gear are still displayed.

- ① Engine speed (p. 36)
- ① Shift warning light (p. 36)

7 COMBINATION INSTRUMENT

- ① The shift warning light is integrated in the tachometer display.
- ② Speedometer (📖 p. 37)
- ③ Unit for the engine speed display
- ④ Gear display (📖 p. 38)
- ⑤ Coolant temperature indicator (📖 p. 38)
- ⑥ **Ride-Mode** display (📖 p. 38)
- ⑦ Speedometer units
- ⑧ **Load** display (📖 p. 38)
- ⑨ **Damping** display (📖 p. 37)
- ⑩ **MTC** display (📖 p. 37)
- ⑪ **ABS** display (📖 p. 37)
- ⑫ **Favorites** display (📖 p. 40)
- ⑬ Fuel range display
- ⑭ Fuel level display (📖 p. 39)
- ⑮ Seat heating (optional) (📖 p. 39)
- ⑯ Heated grip (optional) (📖 p. 39)

7.8 Track Display (optional)

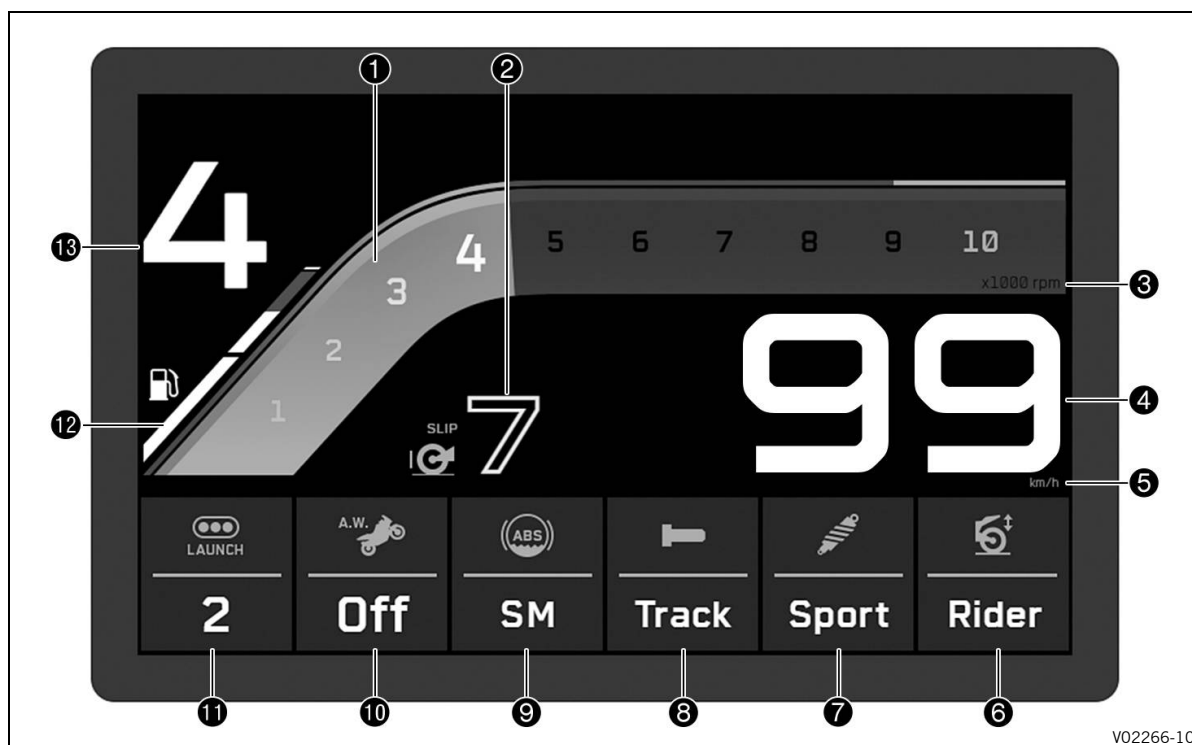

i Info

The figure shows the start screen of the combination instrument when the **Track** riding mode (optional) is active.

All favorites are hidden in **Track** riding mode.

KTM MY RIDE is not available in this mode.

If the menu is open, the speed and the selected gear are still displayed.

- ① Engine speed (📖 p. 36)

- ① Shift warning light (📖 p. 36)
- ② The shift warning light is integrated in the tachometer display.
- ③ Slip adjustment (optional) (📖 p. 135)
- ④ Unit for the engine speed display
- ⑤ Speedometer (📖 p. 37)
- ⑥ Speedometer units
- ⑥ **Load** display (📖 p. 38)
- ⑦ **Damping** display (📖 p. 37)
- ⑧ **Throttle Response** (optional) (📖 p. 135)
- ⑨ **ABS** display (📖 p. 37)
- ⑩ Anti wheelie mode (optional) (📖 p. 78)
- ⑪ Launch Control (optional) (📖 p. 77)
- ⑫ Fuel level display (📖 p. 39)
- ⑬ Gear display (📖 p. 38)

7.9 Performance Display (optional)

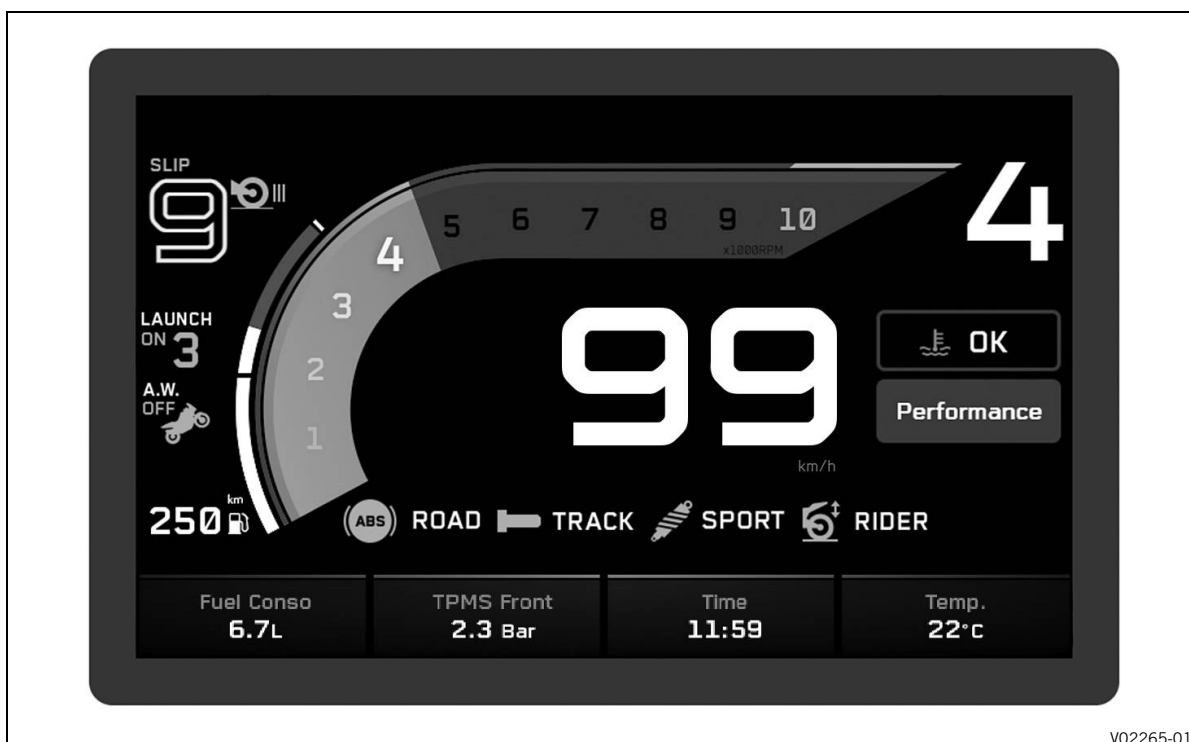

V02265-01



Info

The figure shows the start screen of the combination instrument in active riding mode **Performance** (optional).

In the **Performance** riding mode (optional), the standard view of the combination instrument is combined with the functions of the **Track** riding mode (optional).

If the menu is open, the speed and the selected gear are still displayed.

7.10 Engine speed

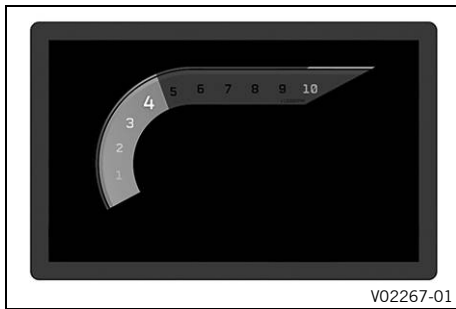

The engine speed is measured in revolutions per minute.

7.11 Shift warning light

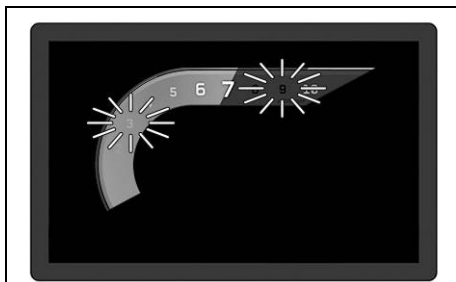

The shift light is integrated in the rpm gauge display. The speed for the shift light can be set in the **Shift Light** menu. The shift warning light is always active during the running-in phase (up to 1,000 km / 621 mi). The shift warning light can only be deactivated, and the values for **RPM1** and **RPM2** can only be adjusted after this. At **RPM1**, the engine speed display flashes red and at **RPM2** the entire display flashes red.

i Info

After the first service, the shift warning light is deactivated when the engine is warm and in sixth-gear.

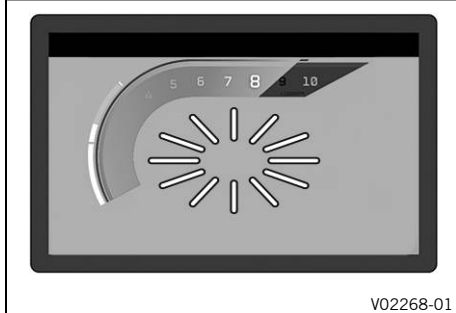

Coolant temperature	≤ 35 °C (≤ 95 °F)
ODO	< 1,000 km (< 620 mi)
The shift warning light always lights up at	6,500 rpm

Coolant temperature	> 35 °C (> 95 °F)
ODO	> 1,000 km (> 620 mi)
RPM1 Engine speed display	flashes red
RPM2 entire display	flashes red

7.12 Cruise control indicator

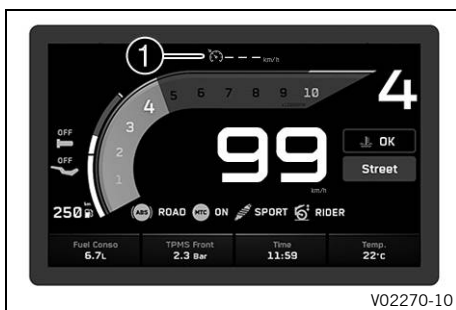

The operating state and active cruise control are shown in the ① area of the display.

Cruise control is operated using the cruise control tip switch (p. 18).

i Info

If the cruise control system function is switched on but cruise control is not activated, the cruise control system indicator lamp lights up yellow.

If the cruise control system function is switched on and cruise control is activated, the cruise control system indicator lamp lights up green.

7.13 Speedometer

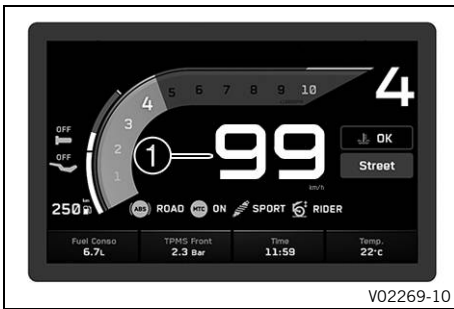

The speed is shown in area **1** of the display.
The unit of speed can be configured in the **Units** menu.
Speed is shown in kilometers per hour **km/h** or in miles per hour **mph**.

7.14 ABS display

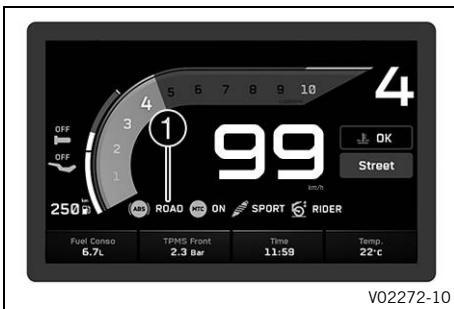

The ABS mode setting is shown in the **1** area of the display.
The ABS can be configured in the **ABS** menu.

7.15 MTC display

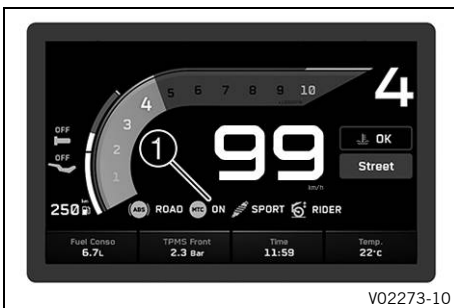

The **1** area of the display indicates whether **MTC** the system is switched on or off.
The motorcycle traction control can be switched on or off in the **MTC** menu.

7.16 Damping display

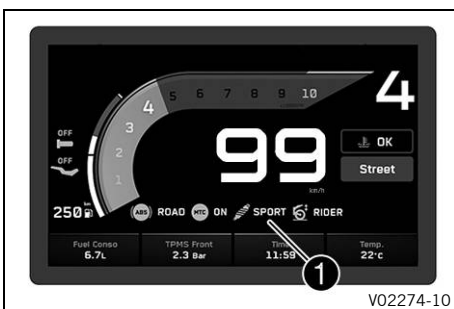

The set **Damping** mode is displayed in the **1** area of the display.
The damping can be configured in the **Damping** menu.

7.17 Load display

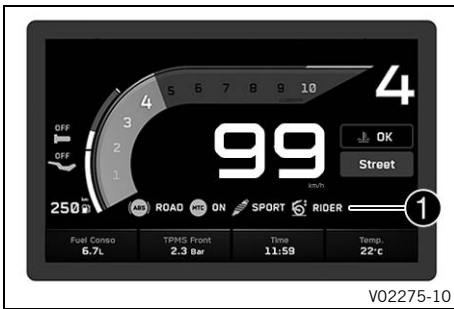

The payload setting is shown in area **1** of the display. The payload can be configured in the **Load** menu. Only configure the payload in an unloaded state.

7.18 Coolant temperature indicator

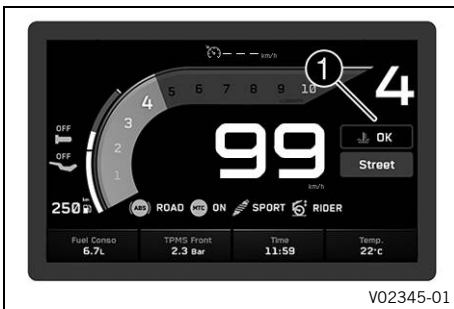

The coolant temperature is shown in area **1** of the display.

i Info
If the coolant temperature indicator shows **HOT**, the indicator also starts to flash.

Possible states

- The engine is cold – The coolant temperature indicator shows **LOW**.
- Engine warm – The coolant temperature indicator shows **OK**.
- Engine hot – The coolant temperature indicator shows **HOT**.

7.19 Ride-Mode display

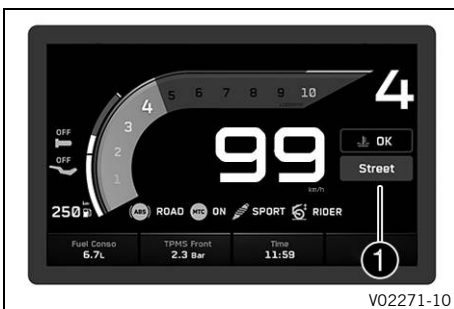

The **Ride Mode** setting is shown in area **1** of the display. The riding mode can be configured in the menu **Ride Mode**.

7.20 Gear display

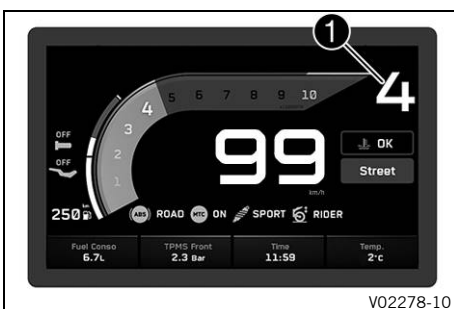

The current gear is shown in area **1** of the display.

7.21 Heated grip (optional)

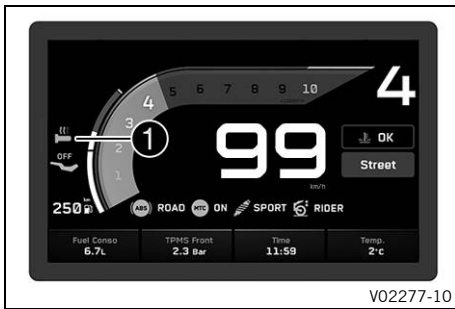

The status of the grip heater is shown in area **1** of the display. The grip heater can be configured in the **Heating** menu.

7.22 Seat heating (optional)

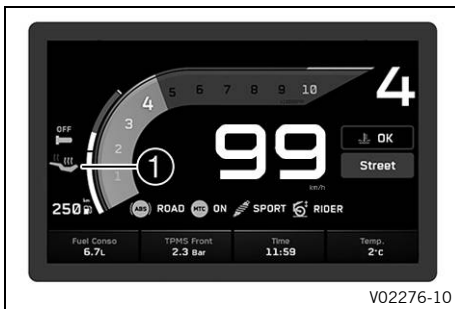

The status of the seat heating is shown in area **1** of the display. The seat heating can be configured in the **Heating** menu.

i Info

The heating level for the passenger seat heating can be controlled by a switch next to the right grab handle.

7.23 Fuel level display

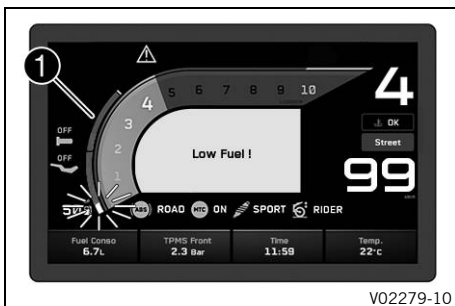

The fuel tank capacity is shown in area **1** of the display. The fuel level indicator consists of bars. The more bars are lit, the more fuel is in the fuel tank.

i Info

If the fuel level is getting low, the last segment flashes red and the following warning **Low Fuel I** also appears. The fuel level is displayed with a slight delay to prevent the indicator from constantly moving while riding. The fuel level display is not updated while the side stand is folded out or the emergency off switch is switched off. Once the side stand is folded up and the emergency OFF switch is switched on, the fuel level display is next updated after 2 minutes. The fuel level display flashes if the combination instrument does not receive a signal from the fuel level sensor.

7.24 Favorites display

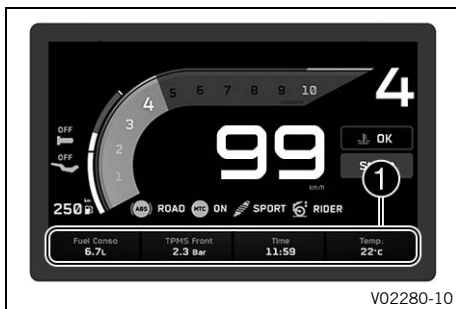

Up to four items of information are displayed in the **Favorites** display **1**.

The favorites display can be freely configured in the **Favorites** menu.

7.25 Navigation display (optional)

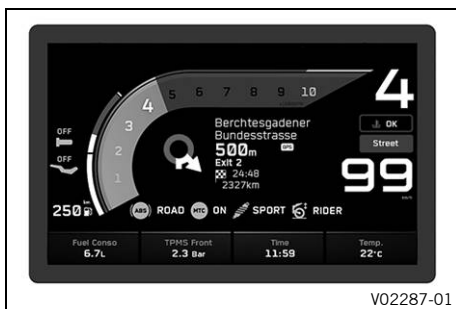

The **Navigation** indicator appears when the navigation function is activated.

The **Navigation** display shows the direction arrow, the distance to the next waypoint, the road name, the arrival time as well as the distance to the destination.

7.26 Call display

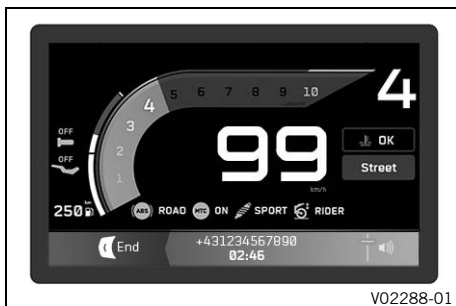

Warning

Danger of accidents Headphone volume which is too high distracts attention from traffic activity.

- Always select headphone volume which is low enough for you to still clearly hear acoustic signals.

The **Call** indicator appears for incoming or active calls.

Press the **RIGHT** button to accept an incoming call.

Press the **LEFT** button to reject an incoming call.

Press the **UP** button to increase the audio volume.

Press the **DOWN** button to reduce the audio volume.



Info

It is not possible to change the audio volume using the combination switch with every cellphone.

The call duration and contact are displayed. Depending on the cellphone settings, the contact is shown by name.

You cannot navigate in the menu during an active phone conversation.

7.27 Menu

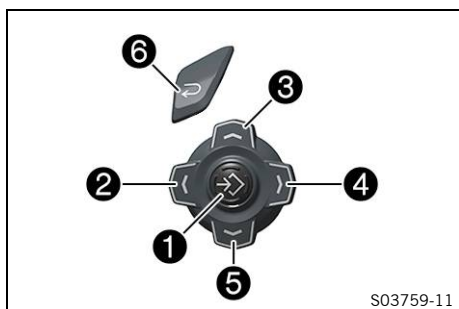

i Info

Press the **SET** button **1** in the start screen to open the menu.

Use the **LEFT** button **2**, the **UP** button **3**, the **RIGHT** button **4** and the **DOWN** button **5** to navigate in the menu.

Press the **BACK** button **6** to close the current menu or the menu overview.

7.27.1 Bike Info



- Press the **SET** button or **RIGHT** button when the menu is closed.
- Press the **UP** or **DOWN** button until **Bike Info** is highlighted. Press the **SET** or **RIGHT** button to open the menu.

General information can be accessed in **Bike Info**.

7.27.2 Bike Info



- Press the **SET** button or **RIGHT** button when the menu is closed.
- Press the **UP** or **DOWN** button until **Bike Info** is highlighted. Press the **SET** or **RIGHT** button to open the menu.

TPMS Front (optional function) shows the current tire pressure of the front tire.

TPMS Rear (optional function) shows the current tire pressure of the rear tire.

i Info

The set reference value is displayed on the right of the current tire pressure in parentheses.

The tire pressure monitoring system mode can be set in the menu **TPMS Mode** (optional function).

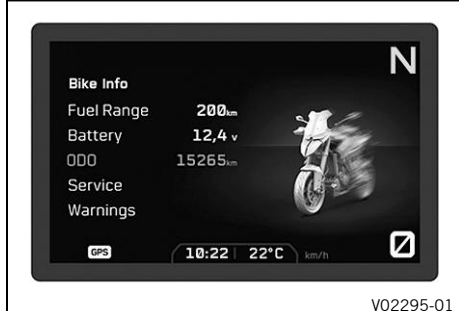

Water displays the coolant temperature.

Oil displays the engine oil temperature.

Fuel Range displays the possible distance you can cover with the fuel reserve.

Battery displays the battery voltage.

ODO displays the total distance covered.

Service displays when the next service is due.

Warnings displays warnings that have occurred until they are no longer active.

7.27.3 Trip

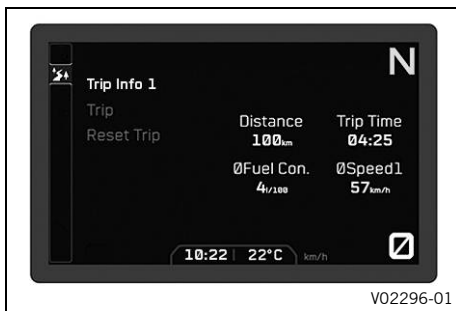

- Press the **SET** button or **RIGHT** button when the menu is closed.
- Press the **UP** or **DOWN** button until **Trip** is highlighted. Press the **SET** or **RIGHT** button to open the menu.

General information on the odometer, riding time, average fuel consumption, and average speed can be accessed in **Trip**. The trips can be switched and reset.

7.27.4 Trip 1



- Press the **SET** or **RIGHT** button when the menu is closed.
- Press the **UP** or **DOWN** button until **Trip** is highlighted. Press the **SET** or **RIGHT** button to open the menu.
- Press the **UP** or **DOWN** button until **Trip** is highlighted. Press the **RIGHT** or **LEFT** button until **Trip 1** is selected.

Trip displays the distance since the last reset, such as between two refueling stops. **Trip** is running and counts up to **9999**. **ØConsum.** indicates the average fuel consumption based on **Trip**. **ØSpeed** indicates the average speed based on **Trip** and **Time**. **Time** displays the trip time on the basis of **Trip** and runs as soon as the combination instrument receives a speed signal.

i Info

All data for the currently selected trip odometer is reset with **Reset Trip**.

7.27.5 Trip 2



- Press the **SET** or **RIGHT** button when the menu is closed.
- Press the **UP** or **DOWN** button until **Trip** is highlighted. Press the **SET** or **RIGHT** button to open the menu.
- Press the **UP** or **DOWN** button until **Trip** is highlighted. Press the **RIGHT** or **LEFT** button until **Trip 2** is selected.

Trip displays the distance since the last reset, such as between two refueling stops. **Trip** is running and counts up to **9999**. **ØConsum.** indicates the average fuel consumption based on **Trip**. **ØSpeed** indicates the average speed based on **Trip** and **Time**. **Time** displays the trip time on the basis of **Trip** and runs as soon as the combination instrument receives a speed signal.

i Info

All data for the currently selected trip odometer is reset with **Reset Trip**.

7.27.6 Motorcycle



- Press the **SET** button or **RIGHT** button when the menu is closed.
- Press the **UP** or **DOWN** button until **Motorcycle** is highlighted. Press the **SET** or the **RIGHT** button to open the menu.

The ride mode, ABS mode, and traction control of the vehicle can be configured in **Motorcycle**.

When the **Track Performance** riding mode (optional) is activated, the characteristics of the throttle response and slip on the rear wheel, the **Anti Wheelie Mode** and the **Launch Control** can be configured.

7.27.7 Ride Mode

**Condition**

- Start button/emergency OFF switch on (middle position) – This position is required for operation; the ignition circuit is closed. (🗨 p. 20)
- Cruise control function deactivated.
- Press the **SET** button or **RIGHT** button when the menu is closed.
- Press the **UP** or **DOWN** button until **Motorcycle** is highlighted. Press the **SET** or the **RIGHT** button to open the menu.

**Warning**

Danger of accidents An incorrectly selected riding mode makes control of the vehicle considerably more difficult.

The riding modes are each only suitable for certain conditions.

- Always select a riding mode that suits the surface on which you are riding, the weather and the riding situation.

- Press the **UP** or **DOWN** button until **Ride Mode** is highlighted.
- Press the **RIGHT** or **LEFT** button to select the **Ride Mode** to change the settings of the engine and motorcycle traction control that are coordinated with each other.
 - ✓ **Street** - Homologated performance with balanced response; the motorcycle traction control allows normal slip on the rear wheel.
 - ✓ **Sport**- Homologated performance with very direct response; the motorcycle traction control allows greater slip on the rear wheel.
 - ✓ **Rain** - Reduced homologated performance with soft response for improved rideability on surfaces with low road grip; the motorcycle traction control allows very little slip on the rear wheel.
 - ✓ **Track** (optional) – homologated performance and extremely direct response. The motorcycle traction control and the characteristics of the throttle response can be set individually.

- ✓ **Performance** (optional) – homologated performance and extremely direct response. The motorcycle traction control and the characteristics of the throttle response can be set individually. Combines the functions of track mode with standard modes.



Info

Do not open the throttle during the selection.

7.27.8 ABS

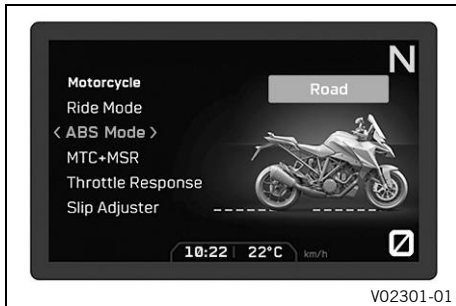

Condition

- The motorcycle is stationary.
- Press the **SET** button or **RIGHT** button when the menu is closed.
- Press the **UP** or **DOWN** button until **Motorcycle** is highlighted. Press the **SET** or the **RIGHT** button to open the menu.
- Press the **UP** or **DOWN** button until **ABS** is highlighted.
- Press the **RIGHT** or **LEFT** button to select between ABS modes.



Info

The ABS mode can be switched during the journey.

Do not open the throttle during the selection.

When the ABS mode **Road** is active, ABS controls both wheels.

When the **Supermoto** ABS mode is active, ABS only controls the front wheel. The rear wheel is not controlled by ABS and may lock during braking maneuvers.

7.27.9 MTC



Condition

- The motorcycle is stationary.
- Cruise control function deactivated.
- Press the **SET** button or **RIGHT** button when the menu is closed.
- Press the **UP** or **DOWN** button until **Motorcycle** is highlighted. Press the **SET** or the **RIGHT** button to open the menu.
- Press the **UP** or **DOWN** button until **MTC** is highlighted.
- Press the **RIGHT** or **LEFT** button to switch the **MTC** on or off.



Info

Do not open the throttle when switching on or off.

Press the **RIGHT** or **LEFT** button briefly when activating the motorcycle traction control.

Hold down the **RIGHT** or **LEFT** button when switching off the motorcycle traction control.

After the ignition is switched on, motorcycle traction control is enabled again.

7.27.10 MTC+MSR (optional)

**Condition**

- The motorcycle is stationary.
- Cruise control function deactivated.
- Press the **SET** button or **RIGHT** button when the menu is closed.
- Press the **UP** or **DOWN** button until **Motorcycle** is highlighted. Press the **SET** or the **RIGHT** button to open the menu.
- Press the **UP** or **DOWN** button until **MTC** is highlighted.
- Press the **RIGHT** or **LEFT** button to switch the **MTC** on or off.

**Info**

Do not open the throttle when switching on or off. Press the **RIGHT** or **LEFT** button briefly when activating the motorcycle traction control. Hold down the **RIGHT** or **LEFT** button when switching off the motorcycle traction control. After the ignition is switched on, motorcycle traction control is enabled again.

7.27.11 Throttle Response (optional)

**Condition**

- The riding mode **Track** (optional) or **Performance** (optional) is activated.
- Press the **SET** button or **RIGHT** button when the menu is closed.
- Press the **UP** or **DOWN** button until **Motorcycle** is highlighted. Press the **SET** or the **RIGHT** button to open the menu.

**Warning**

Danger of accidents An incorrectly selected riding mode makes control of the vehicle considerably more difficult.

The riding modes are each only suitable for certain conditions.

- Always select a riding mode that suits the surface on which you are riding, the weather and the riding situation.

- Press the **UP** or **DOWN** button until **Throttle Response** is highlighted.
- Press **RIGHT** or **LEFT** button to select **Throttle Response** mode.
 - ✓ **Street** - Balanced response.
 - ✓ **Sport** - Very direct response.
 - ✓ **Track** - Extremely direct response.

**Info**

Do not open the throttle when setting the throttle response.

7.27.12 Slip Adjuster (optional)



Condition

- The riding mode **Track** (optional) or **Performance** (optional) is activated.
- **MTC** is activated.
 - Press the **SET** button or **RIGHT** button when the menu is closed.
 - Press the **UP** or **DOWN** button until **Motorcycle** is highlighted. Press the **SET** or the **RIGHT** button to open the menu.
 - Press the **UP** or **DOWN** button until **Slip Adjuster** is highlighted.
 - Press the **RIGHT** or **LEFT** button to set the maximum permitted slip of the motorcycle traction control.

Info

Do not open the throttle during the selection.

The spin adjuster is a motorcycle traction control function. The slip adjustment allows the motorcycle traction control to be tuned through nine levels to the desired characteristic map. Level 1 allows the maximum slip on the rear wheel, and level 9 the minimum.

If the cruise control function is deactivated, the **+RES** and **-SET** buttons in the main display or in the **Slip Adjuster** menu can be used to adjust the **Slip Adjuster**.

Info

The slip adjustment is only available in **Track** riding mode (optional) or **Performance**(optional). The spin adjuster is only available when motorcycle traction control is activated.

7.27.13 Anti Wheelie Mode (optional)



Condition

- The riding mode **Track** (optional) or **Performance** (optional) is activated.
- Press the **SET** button or **RIGHT** button when the menu is closed.
- Press the **UP** or **DOWN** button until **Motorcycle** is highlighted. Press the **SET** or the **RIGHT** button to open the menu.



Warning

Danger of accidents When Anti Wheelie Mode is disabled, the motorcycle traction control no longer counteracts the raising of the front wheel.

- Only switch off the Anti Wheelie Mode if you have the appropriate experience.

- Press the **UP** or **DOWN** button until **Anti Wheelie Mode** is highlighted.
- Press the **RIGHT** or **LEFT** button to switch **Anti Wheelie Mode** on or off.

7.27.14 Launch Control (optional)

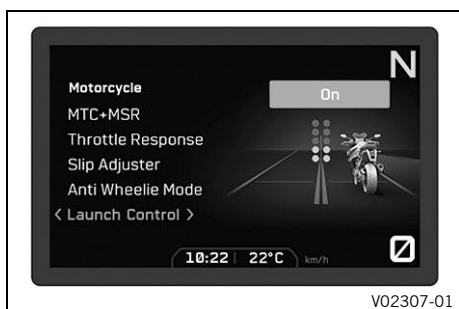

Condition

- The riding mode **Track** (optional) or **Performance** (optional) is activated.
- Press the **SET** button or **RIGHT** button when the menu is closed.
- Press the **UP** or **DOWN** button until **Motorcycle** is highlighted. Press the **SET** or the **RIGHT** button to open the menu.



Warning

Danger of accidents Launch control enables very powerful acceleration which may ask too much of a novice rider.

- Only use the launch control if you have the appropriate experience.
 - Do not use launch control on public roads.
- Press the **UP** or **DOWN** button until **Launch Control** is highlighted.
 - Press the **RIGHT** or **LEFT** button to switch **Launch Control** on or off.

7.27.15 Suspension

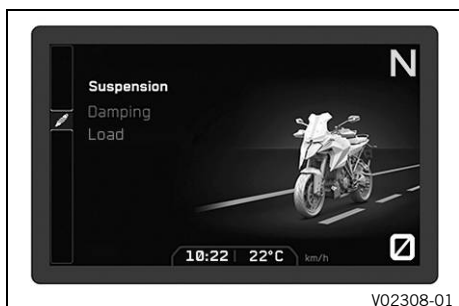

- Press the **SET** button or **RIGHT** button when the menu is closed.
- Press the **UP** or **DOWN** button until **Suspension** is highlighted. Press the **SET** or the **RIGHT** button to open the menu.

The damping and payload can be configured in **Suspension**.

7.27.16 Damping



Condition

- The motorcycle is stationary.
- Press the **UP** or **DOWN** button until **Suspension** is highlighted. Press the **SET** or the **RIGHT** button to open the menu.
- Press the **UP** or **DOWN** button until **Damping** is highlighted.
- Press the **RIGHT** or **LEFT** button to configure the damper setting.

The damping setting of the suspension components is shown in the **Damp** display.

In the **Damping** menu, you can select from the settings **SPORT**, **STREET**, and **COMFORT**.

7.27.17 Load



V02310-01

Condition

- The motorcycle is stationary and is unloaded.
- Engine is running.
- Press the **UP** or **DOWN** button until **Suspension** is highlighted. Press the **SET** or the **RIGHT** button to open the menu.
- Press the **UP** or **DOWN** button until **Load** is highlighted.
- Press the **RIGHT** or **LEFT** button to select the payload.

In the **Load** menu, you can select from four payloads. The setting of the spring preload and the rebound is adjusted for the payload.

7.27.18 Navigation (optional)

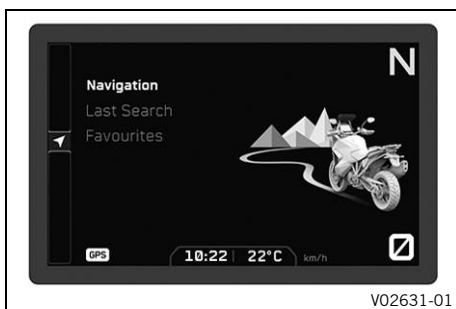

V02631-01

Condition

- **Bluetooth®** function is activated.
- The **KTMconnect** app (optional) is installed and opened on a suitable cellphone (Android devices Version 7.0 and higher, iOS devices Version 13 and higher).
- The combination instrument is connected to a suitable phone.
- The GPS function is activated on the connected phone.
- For voice navigation: The combination instrument is connected to a suitable headset and an appropriate language package has been downloaded in the **KTMconnect** app.
- Press the **SET** button or **RIGHT** button when the menu is closed.
- Press the **UP** or **DOWN** button until **Navigation** is highlighted. Press the **SET** or **RIGHT** button to open the menu.

You can select the last destinations and favorites, skip waypoints, configure the volume of the voice navigation and start the navigation in the **Navigation** menu.

i Info

The **Audio** function can be used with the navigation function at the same time.

When the navigation function is switched on and the device is connected, the **GPS** symbol appears on the combination instrument display.

7.27.19 Last search (optional)

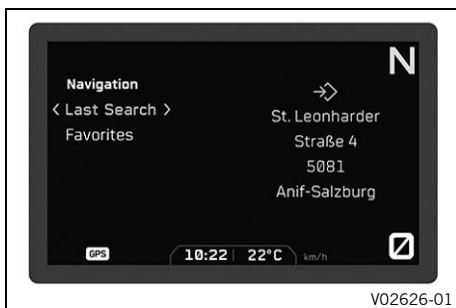

V02626-01

Condition

- **Bluetooth®** function is activated.
- The **KTMconnect** app (optional) is installed and opened on a suitable cellphone (Android devices Version 7.0 and higher, iOS devices Version 13 and higher).
- The combination instrument is connected to a suitable phone.
- The GPS function is activated on the connected phone.
- For voice navigation: The combination instrument is connected to a suitable headset and an appropriate language package has been downloaded in the **KTMconnect** app.
- The addresses sought can be found in the **KTMconnect** app.
- Press the **SET** button or **RIGHT** button when the menu is closed.

- Press the **UP** or **DOWN** button until **Navigation** is highlighted. Press the **SET** or **RIGHT** button to open the menu.
- Press the **UP** or **DOWN** button until **Last search** is highlighted. Press the **RIGHT** or **LEFT** button to select an address.
- Press the **SET** button to confirm the selection and start navigation.

**Info**

The last 10 addresses sought in the **KTMconnect** app are saved in **Last search**.

7.27.20 Favorites (optional)



V02627-01

Condition

- **Bluetooth®** function is activated.
 - The **KTMconnect** app (optional) is installed and opened on a suitable cellphone (Android devices Version 7.0 and higher, iOS devices Version 13 and higher).
 - The combination instrument is connected to a suitable phone.
 - The GPS function is activated on the connected phone.
 - For voice navigation: The combination instrument is connected to a suitable headset and an appropriate language package has been downloaded in the **KTMconnect** app.
 - Favorites are saved in the **KTMconnect** app.
- Press the **SET** button or **RIGHT** button when the menu is closed.
 - Press the **UP** or **DOWN** button until **Navigation** is highlighted. Press the **SET** or **RIGHT** button to open the menu.
 - Press the **UP** or **DOWN** button until **Favorites** is highlighted. Press the **RIGHT** or **LEFT** button to select an address.
 - Press the **SET** button to confirm the selection and start navigation.

**Info**

10 addresses in the **KTMconnect** app can be stored in **Favorites**.

7.27.21 Skip Waypoint (optional)



Condition

- **Bluetooth®** function is activated.
- The **KTMconnect** app (optional) is installed and opened on a suitable cellphone (Android devices Version 7.0 and higher, iOS devices Version 13 and higher).
- The combination instrument is connected to a suitable phone.
- The GPS function is activated on the connected phone.
- For voice navigation: The combination instrument is connected to a suitable headset and an appropriate language package has been downloaded in the **KTMconnect** app.
- Navigation with at least one interim destination has been started in the **KTMconnect** app.
 - Press the **SET** button or **RIGHT** button when the menu is closed.
 - Press the **UP** or **DOWN** button until **Navigation** is highlighted. Press the **SET** or **RIGHT** button to open the menu.
 - Press the **UP** or **DOWN** button until **Skip Waypoint** is highlighted. Press **SET** to select the waypoint.
 - Press the **SET** button again to confirm the selection and the waypoint is removed.

7.27.22 Volume (optional)



Condition

- **Bluetooth®** function is activated.
- The **KTMconnect** app (optional) is installed and opened on a suitable cellphone (Android devices Version 7.0 and higher, iOS devices Version 13 and higher).
- The combination instrument is connected to a suitable phone.
- The GPS function is activated on the connected phone.
- For voice navigation: The combination instrument is connected to a suitable headset and an appropriate language package has been downloaded in the **KTMconnect** app.
 - Press the **SET** button or **RIGHT** button when the menu is closed.
 - Press the **UP** or **DOWN** button until **Navigation** is highlighted. Press the **SET** or **RIGHT** button to open the menu.



Warning

Danger of accidents Headphone volume which is too high distracts attention from traffic activity.

- Always select headphone volume which is low enough for you to still clearly hear acoustic signals.

- Press the **UP** or **DOWN** button until **Volume** is highlighted.



Info

Press the **RIGHT** button to increase the audio volume. Press the **LEFT** button to reduce the audio volume.

The volume of the navigation can be set in the **Volume** submenu.

7.27.23 Stop Navigation (optional)



Condition

- **Bluetooth®** function is activated.
- The **KTMconnect** app (optional) is installed and opened on a suitable cellphone (Android devices Version 7.0 and higher, iOS devices Version 13 and higher).
- The combination instrument is connected to a suitable phone.
- The GPS function is activated on the connected phone.
- For voice navigation: The combination instrument is connected to a suitable headset and an appropriate language package has been downloaded in the **KTMconnect** app.
 - Press the **SET** button or **RIGHT** button when the menu is closed.
 - Press the **UP** or **DOWN** button until **Navigation** is highlighted. Press the **SET** or **RIGHT** button to open the menu.
 - Press the **UP** or **DOWN** button until **Stop Navigation** is highlighted. Press the **SET** button to confirm the selection.
 - Press the **SET** button to confirm the selection and end navigation.

7.27.24 Heating (optional)



- Press the **SET** button or **RIGHT** button when the menu is closed.
- Press the **UP** or **DOWN** button until **Heating** is highlighted. Press the **SET** or the **RIGHT** button to open the menu.

The grip heater (optional) and front rider's seat heating (optional) can be configured in **Heating**.

7.27.25 Heating Grips (optional)

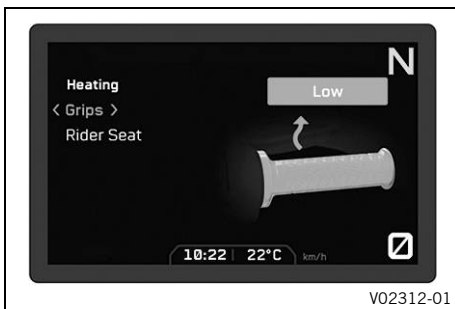

Condition

- Model with heated grip.
- **Heating Grip** menu (optional) activated.
 - Press the **SET** button when the menu is closed.
 - Press the **UP** or **DOWN** button until **Heating** is highlighted. Press the **SET** or **RIGHT** button to open the menu.
 - Press the **UP** or **DOWN** button until **Grips** is highlighted.
 - Press the **RIGHT** or **LEFT** button to select the heating level or switch the heated grips on or off.

7.27.26 Heating Rider Seat (optional)

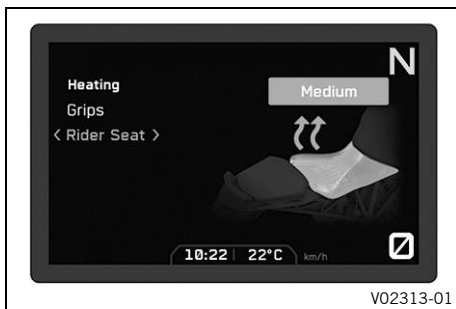

V02313-01

Condition

- Model with seat heater.
- **Heating Seat Rider** menu (optional) activated.
- Press the **SET** button when the menu is closed.
- Press the **UP** or **DOWN** button until **Heating** is highlighted. Press the **SET** or **RIGHT** button to open the menu.
- Press the **UP** or **DOWN** button until **Rider Seat** is highlighted.
- Press the **RIGHT** or **LEFT** button to select the heating level or switch the front rider's seat heating on or off.



Info

The heating level for the passenger seat heating (optional) is selected using the switch next to the right grab handle.

7.27.27 Audio



V02314-01

Condition

- **Bluetooth**® function is activated.
- The combination instrument is connected to a suitable phone.
- The combination instrument is connected to a suitable headset or the **Headset Type Corded** is selected.
- Press the **SET** button or **RIGHT** button when the menu is closed.



Warning

Danger of accidents Headphone volume which is too high distracts attention from traffic activity.

- Always select headphone volume which is low enough for you to still clearly hear acoustic signals.

- Press the **UP** or **DOWN** button until **Audio** is highlighted. Press the **SET** or the **RIGHT** button to open the menu.

You can control the volume and track selection in **Audio**.

7.27.28 Audio



V02315-01

Condition

- **Bluetooth**® function is activated.
- The combination instrument is connected to a suitable phone.
- The combination instrument is connected to a suitable headset or the **Headset Type Corded** is selected.



Warning

Danger of accidents Headphone volume which is too high distracts attention from traffic activity.

- Always select headphone volume which is low enough for you to still clearly hear acoustic signals.

- Press the **UP** or **DOWN** button until **Audio** is highlighted. Press the **SET** or **RIGHT** button to open the menu.
- Press the **UP** button to increase the audio volume.

- Press the **DOWN** button to reduce the audio volume.
- Press the **RIGHT** button change to the next audio track.
- Pressing the **LEFT** button changes to the previous audio track or plays the current audio track from the start, depending on the cellphone model.
- Press the **SET** button to play or pause the audio track.



Tip

With some cellphones, the audio player needs to be started before playback is possible.
The **Audio** function can be added to **C1** or **C2** for easier operation.

7.27.29 Settings



V02316-01

Condition

- The motorcycle is stationary.
- Press the **SET** button or **RIGHT** button when the menu is closed.
- Press the **UP** or **DOWN** button until **Settings** is highlighted.
Press the **SET** or the **RIGHT** button to open the menu.

Favorites, quick selections and the combination instrument display can be configured in **Settings**.

Settings can be made for units or various values. Several functions can be enabled or disabled.

7.27.30 Custom Switch



V02317-01

Condition

- The motorcycle is stationary.
- Press the **SET** button or **RIGHT** button when the menu is closed.
- Press the **UP** or **DOWN** button until **Settings** is highlighted.
Press the **SET** or the **RIGHT** button to open the menu.
- Press the **UP** or **DOWN** button until **Custom Switch** is highlighted.
- Press the **SET** button to open the menu.

The quick access buttons can be freely configured in **Custom Switch**.

7.27.31 C1 and C2 buttons

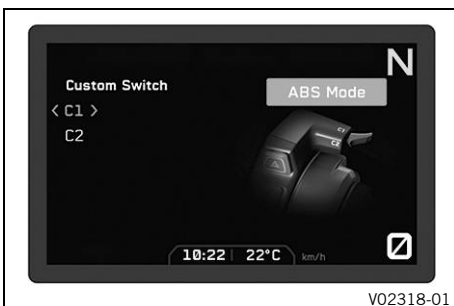

V02318-01

Condition

- The motorcycle is stationary.
- Press the **SET** button or **RIGHT** button when the menu is closed.
- Press the **UP** or **DOWN** button until **Settings** is highlighted.
Press the **SET** or the **RIGHT** button to open the menu.
- Press the **UP** or **DOWN** button until **Custom Switch** is highlighted.
- Press the **SET** button to open the menu.
- Press the **UP** or **DOWN** button until **C1** or **C2** is highlighted.
- Press the **RIGHT** or **LEFT** button to select the desired function.



Info

In the **Custom Switch** menu, the C1 and C2 buttons can be assigned different quick accesses, e.g. **ABS Mode** and **Ride Mode**.

The **C1** switch is used to open the quick access defined in **C1**.

The **C2** switch is used to call up the quick access defined in **C2**.

7.27.32 Favorites



V02340-01

Condition

- The motorcycle is stationary.
- Press the **SET** button or **RIGHT** button when the menu is closed.
- Press the **UP** or **DOWN** button until **Settings** is highlighted. Press the **SET** or the **RIGHT** button to open the menu.
- Press the **UP** or **DOWN** button until **Favorites** is highlighted.
- Press the **SET** button to open the menu.

In **Favorites**, up to four items of information, e.g. **Oil Temperature** and **Battery**, can be selected for display in the **Favorites** indicator on the display.

7.27.33 Favorites indicator 1-4

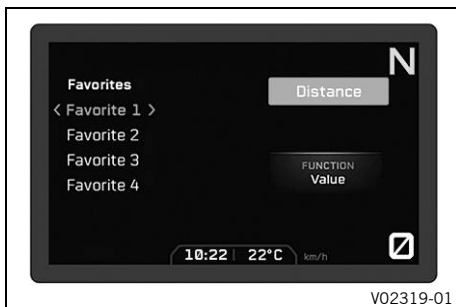

V02319-01

Condition

- The motorcycle is stationary.
- Press the **SET** button or **RIGHT** button when the menu is closed.
- Press the **UP** or **DOWN** button until **Settings** is highlighted. Press the **SET** or the **RIGHT** button to open the menu.
- Press the **UP** or **DOWN** button until **Favorites** is highlighted.
- Press the **SET** button to open the menu.
- Press the **UP** or **DOWN** button until **Favorite 1**, **Favorite 2**, **Favorite 3**, or **Favorite 4** is highlighted.
- Press the **RIGHT** or **LEFT** button to select the desired information.

7.27.34 Button Illumination



V02320-01

Condition

- The motorcycle is stationary.
- Press the **SET** button or **RIGHT** button when the menu is closed.
- Press the **UP** or **DOWN** button until **Settings** is highlighted. Press the **SET** or the **RIGHT** button to open the menu.
- Press the **UP** or **DOWN** button until **Button Illumination** is highlighted.
- Press the **RIGHT** or **LEFT** button to select the button illumination level or switch off the button illumination.

7.27.35 DRL

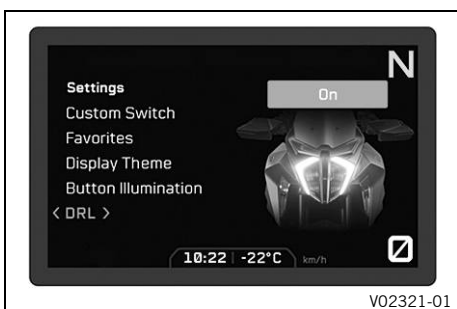
**Condition**

- The motorcycle is stationary.
- Model with **DRL**.
- Press the **SET** button or **RIGHT** button when the menu is closed.
- Press the **UP** or **DOWN** button until **Settings** is highlighted. Press the **SET** or the **RIGHT** button to open the menu.
- Press the **UP** or **DOWN** button until **DRL** is highlighted.

**Warning**

Danger of accidents When visibility is poor, the daytime running light is not a substitute for the low beam. Automatic switching between the daytime running light and low beam may only be partially available when visibility is significantly impaired due to fog, snow or rain.

- Ensure that the appropriate type of lighting is always selected.
 - If necessary switch off the daytime running lights using the menu before going on a ride or when stopped so that the low beam is switched on permanently.
 - Make sure that the daytime running light is deactivated with the diagnostics tool when the menu item is not available, but the low beam is required. (Your authorized KTM workshop will be glad to help.)
 - Note the legal regulations regarding the daytime running light.
- Press the **RIGHT** or **LEFT** button to switch the daytime running light on or off.

**Info**

After the ignition is switched back on, the daytime running light is reactivated.

7.27.36 KTMconnect

**Condition**

- The motorcycle is stationary.
- Press the **SET** button or **RIGHT** button when the menu is closed.
- Press the **UP** or **DOWN** button until **Settings** is highlighted. Press the **SET** or the **RIGHT** button to open the menu.
- Press the **UP** or **DOWN** button until **KTMconnect** is highlighted.
- Press the **SET** button to open the menu.

A suitable cellphone or headset can be paired with the vehicle and the headset type set via **Bluetooth®** in the **KTMconnect** menu.

7.27.37 Bluetooth

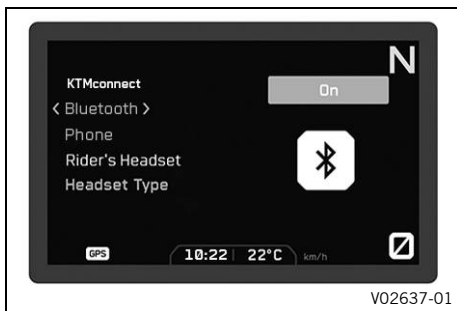

Condition

- The motorcycle is stationary.
- Press the **SET** button or **RIGHT** button when the menu is closed.
- Press the **UP** or **DOWN** button until **Settings** is highlighted. Press the **SET** or the **RIGHT** button to open the menu.
- Press the **UP** or **DOWN** button until **KTMconnect** is highlighted.
- Press the **SET** button to open the menu.
- Press the **UP** or **DOWN** button until **Bluetooth** is highlighted.
- Press the **RIGHT** or **LEFT** button to switch **Bluetooth** on or off.

The function **Bluetooth®** must be activated to pair a suitable cell-phone or headset with the vehicle.

Not every phone and headset is suitable for pairing with the vehicle.

7.27.38 Phone



Condition

- The motorcycle is stationary.
- **Bluetooth** function is activated.
- The **Bluetooth®** function should also be activated in the device to be paired.
- Press the **SET** button or **RIGHT** button when the menu is closed.
- Press the **UP** or **DOWN** button until **Settings** is highlighted. Press the **SET** or the **RIGHT** button to open the menu.
- Press the **UP** or **DOWN** button until **KTMconnect** is highlighted.
- Press the **SET** button to open the menu.
- Press the **UP** or **DOWN** button until **Phone** is highlighted. Press the **SET** or **RIGHT** button to open the menu.

Info

Only one cellphone can be paired with the vehicle.

- Press the **UP** or **DOWN** button until **New Pairing** is highlighted. Press the **SET** button to open the submenu.
- The vehicle starts searching for a suitable cellphone. If the search was successful, the name of the cellphone is displayed in the **New Pairing** submenu. Press the **SET** button to start the pairing.

Info

The cellphone must be visible via **Bluetooth®** for the vehicle to find the cellphone. Make sure that the end device is in the correct pairing mode for call administration. If the end device is only paired for media playback, the call function may not work.

- A message appears on the combination instrument indicating that the vehicle is now ready for pairing. Confirmation of the **Passkey** successfully completes the cellphone pairing.

**Info**

Press the **UP** or **DOWN** button until **Delete Pairing** is highlighted. Press the **SET** button to delete the paired device.

Not every cellphone is suitable for pairing with the vehicle.

- Move the previously paired device into the range of the vehicle while the **Bluetooth®** function is active.
 - ✓ The device is automatically connected with the vehicle.
 - ✗ If the device is not automatically connected with the vehicle after approx. 30 seconds:
 - Switch on the vehicle again or repeat the **New Pairing** procedure.

A suitable cellphone can be paired with the vehicle in the **Phone** submenu.

7.27.39 Rider's Headset

V02635-01

Condition

- The motorcycle is stationary.
- **Bluetooth®** function is activated.
- The **Bluetooth®** function should also be activated in the device to be paired.
- Press the **SET** button or **RIGHT** button when the menu is closed.
- Press the **UP** or **DOWN** button until **Settings** is highlighted. Press the **SET** or the **RIGHT** button to open the menu.
- Press the **UP** or **DOWN** button until **KTMconnect** is highlighted.
- Press the **SET** button to open the menu.
- Press the **UP** or **DOWN** button until **Rider's Headset** is highlighted. Press the **SET** button to open the menu.
- Press the **UP** or **DOWN** button until **New Pairing** is highlighted. Press the **SET** button to open the submenu.
- The vehicle starts searching for a suitable headset. If the search was successful, the name of the rider's headset is displayed in the **New Pairing** submenu. Press the **SET** button to start the pairing.

**Info**

The headset must be in pairing mode for the vehicle to find the headset. Follow the instructions in the headset owner's manual.

Press the **UP** or **DOWN** button until **Delete Pairing** is highlighted. The paired device can be deleted by pressing the **SET** button.

Not every headset is suitable for pairing with the vehicle.

- Move the previously paired device into the range of the vehicle while the **Bluetooth®** function is active.
 - ✓ The device is automatically connected with the vehicle.

- ✘ If the device is not automatically connected with the vehicle after approx. 30 seconds:
 - Switch on the vehicle again or repeat the **New Pairing** procedure.

In the **Rider's Headset** submenu, a suitable rider headset can be paired with the vehicle.

7.27.40 Headset Type



Condition

- The motorcycle is stationary.
- Press the **SET** button or **RIGHT** button when the menu is closed.
- Press the **UP** or **DOWN** button until **Settings** is highlighted. Press the **SET** or the **RIGHT** button to open the menu.
- Press the **UP** or **DOWN** button until **KTMconnect** is highlighted.
- Press the **SET** button to open the menu.
- Press the **UP** or **DOWN** button until **Headset Type** is highlighted. Press the **RIGHT** or **LEFT** button to change the rider headset type.

The connection type of the rider headset can be selected in the **Headset Type** submenu.

The headset is connected directly to the smartphone by a cable or **Bluetooth®** in **Corded** mode.

The headset is connected to the vehicle wirelessly via **Bluetooth®** in **Bluetooth** mode.

Info

The **Rider's Headset** menu item is only available in **Headset Type Bluetooth**.

7.27.41 Quickshifter + (optional)

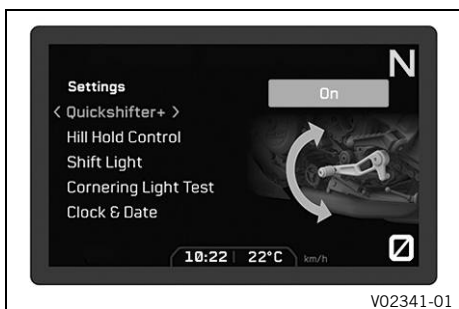

Condition

- The motorcycle is stationary.
- Press the **SET** button or **RIGHT** button when the menu is closed.
- Press the **UP** or **DOWN** button until **Settings** is highlighted. Press the **SET** or the **RIGHT** button to open the menu.
- Press the **UP** or **DOWN** button until **Quickshifter +** is highlighted.
- Press the **RIGHT** or **LEFT** button to switch **Quickshifter +** on or off.

7.27.42 Hill Hold Control (optional)

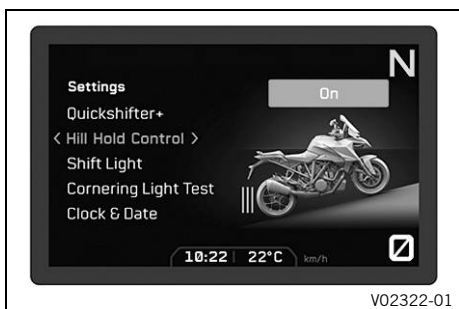

Condition

- The motorcycle is stationary.
- Press the **SET** button or **RIGHT** button when the menu is closed.
- Press the **UP** or **DOWN** button until **Settings** is highlighted. Press the **SET** or the **RIGHT** button to open the menu.
- Press the **UP** or **DOWN** button until **Hill Hold Control** is highlighted.
- Press the **RIGHT** or **LEFT** button to switch the Hill Hold Control on or off.

7.27.43 Shift Light

**Condition**

- The motorcycle is stationary.
- **ODO** > 1,000 km (621 mi).
- Press the **SET** button or **RIGHT** button when the menu is closed.
- Press the **UP** or **DOWN** button until **Settings** is highlighted. Press the **SET** or the **RIGHT** button to open the menu.
- Press the **UP** or **DOWN** button until **Shift Light** is highlighted.
- Press the **SET** button to open the menu.

The speed for the shift warning light can be set in **Shift Light**.

7.27.44 Shift Light State

**Condition**

- The motorcycle is stationary.
- Press the **SET** button or **RIGHT** button when the menu is closed.
- Press the **UP** or **DOWN** button until **Settings** is highlighted. Press the **SET** or the **RIGHT** button to open the menu.
- Press the **UP** or **DOWN** button until **Shift Light** is highlighted.
- Press the **SET** button to open the menu.
- Press the **UP** or **DOWN** button until **State** is highlighted.
- Use the **RIGHT** or **LEFT** button to switch the shift warning light on or off.

7.27.45 Shift Light RPM1

**Condition**

- The motorcycle is stationary.
- Press the **SET** button or **RIGHT** button when the menu is closed.
- Press the **UP** or **DOWN** button until **Settings** is highlighted. Press the **SET** or the **RIGHT** button to open the menu.
- Press the **UP** or **DOWN** button until **Shift Light** is highlighted.
- Press the **SET** button to open the menu.
- Press the **UP** or **DOWN** button until **RPM1** is highlighted.
- Press the **RIGHT** or **LEFT** button to set the value for **RPM1**.

**Info**

RPM1 can be set in intervals of 500 between 5,000 and 10,000 rpm.

RPM1 must not be larger than **RPM2**.

If the engine speed reaches the set value **RPM1**, the shift light flashes red.

7.27.46 Shift Light RPM2



V02326-01

Condition

- The motorcycle is stationary.
- Press the **SET** button or **RIGHT** button when the menu is closed.
- Press the **UP** or **DOWN** button until **Settings** is highlighted. Press the **SET** or the **RIGHT** button to open the menu.
- Press the **UP** or **DOWN** button until **Shift Light** is highlighted.
- Press the **SET** button to open the menu.
- Press the **UP** or **DOWN** button until **RPM2** is highlighted.
- Press the **RIGHT** or **LEFT** button to set the value for **RPM2**.



Info

RPM2 can be set in intervals of 500 between 5,000 and 10,000 rpm.

RPM2 must not be smaller than **RPM1**.

If the engine speed reaches the set value **RPM2**, the entire display flashes red.

7.27.47 Cornering Light Test

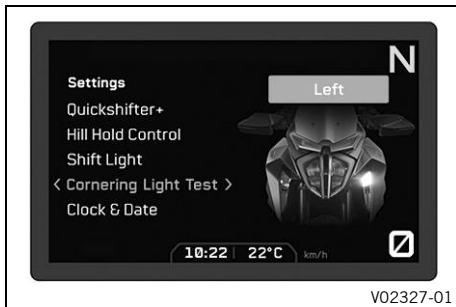

V02327-01

Condition

- The motorcycle is stationary.
- Press the **SET** button or **RIGHT** button when the menu is closed.
- Press the **UP** or **DOWN** button until **Settings** is highlighted. Press the **SET** or the **RIGHT** button to open the menu.
- Press the **UP** or **DOWN** button until **Cornering Light Test** is highlighted.
- Press the **RIGHT** or **LEFT** button to test the left or right cornering light.



Info

After a successful test, the cornering light is automatically switched off again.

7.27.48 Clock & Date

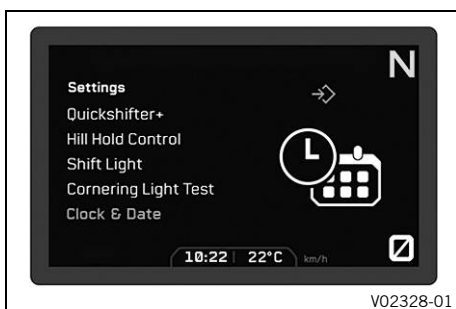

V02328-01

Condition

- The motorcycle is stationary.
- Press the **SET** button or **RIGHT** button when the menu is closed.
- Press the **UP** or **DOWN** button until **Settings** is highlighted. Press the **SET** or the **RIGHT** button to open the menu.
- Press the **UP** or **DOWN** button until **Clock & Date** is highlighted.
- Press the **SET** button to open the menu.

The time, date, and display formats can be set in **Clock & Date**.

7.27.49 Clock Format

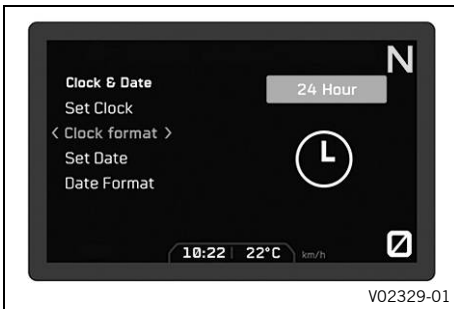

Condition

- The motorcycle is stationary.
- Press the **SET** button or **RIGHT** button when the menu is closed.
- Press the **UP** or **DOWN** button until **Settings** is highlighted. Press the **SET** or the **RIGHT** button to open the menu.
- Press the **UP** or **DOWN** button until **Clock & Date** is highlighted.
- Press the **SET** button to open the menu.
- Press the **UP** or **DOWN** button until **Clock Format** is highlighted.
- Press the **RIGHT** or **LEFT** button to set the time format.

7.27.50 Date Format

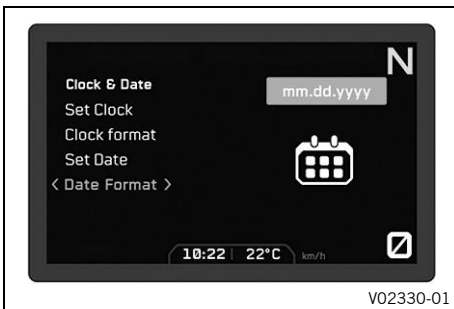

Condition

- The motorcycle is stationary.
- Press the **SET** button or **RIGHT** button when the menu is closed.
- Press the **UP** or **DOWN** button until **Settings** is highlighted. Press the **SET** or the **RIGHT** button to open the menu.
- Press the **UP** or **DOWN** button until **Clock & Date** is highlighted.
- Press the **SET** button to open the menu.
- Press the **UP** or **DOWN** button until **Date Format** is highlighted.
- Press the **RIGHT** or **LEFT** button to set the date format.

7.27.51 Units



Condition

- The motorcycle is stationary.
- Press the **SET** button or **RIGHT** button when the menu is closed.
- Press the **UP** or **DOWN** button until **Settings** is highlighted. Press the **SET** or the **RIGHT** button to open the menu.
- Press the **UP** or **DOWN** button until **Units** is highlighted.
- Press the **SET** button to open the menu.

Units allows settings to be made for units or various values.

7.27.52 Units Distance

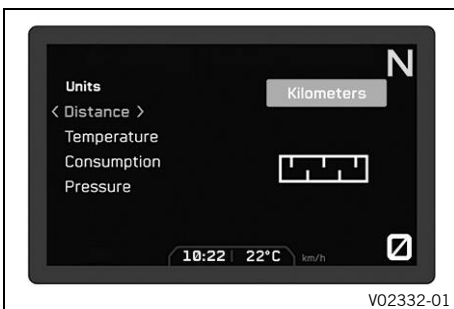

Condition

- The motorcycle is stationary.
- Press the **SET** button or **RIGHT** button when the menu is closed.
- Press the **UP** or **DOWN** button until **Settings** is highlighted. Press the **SET** or the **RIGHT** button to open the menu.
- Press the **UP** or **DOWN** button until **Units** is highlighted.
- Press the **SET** button to open the menu.
- Press the **UP** or **DOWN** button until **Distance** is highlighted.
- Press the **RIGHT** or **LEFT** button to set the distance unit.

7.27.53 Units Temperature

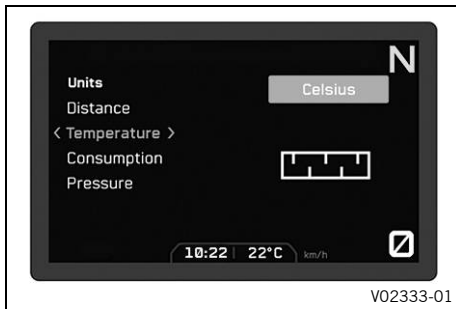

Condition

- The motorcycle is stationary.
- Press the **SET** button or **RIGHT** button when the menu is closed.
- Press the **UP** or **DOWN** button until **Settings** is highlighted. Press the **SET** or the **RIGHT** button to open the menu.
- Press the **UP** or **DOWN** button until **Units** is highlighted.
- Press the **SET** button to open the menu.
- Press the **UP** or **DOWN** button until **Temperature** is highlighted.
- Press the **RIGHT** or **LEFT** button to set the temperature unit.

7.27.54 Units Consumption

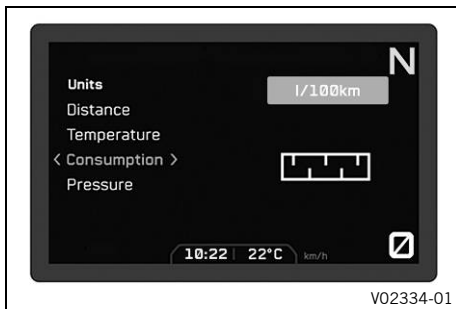

Condition

- The motorcycle is stationary.
- Press the **SET** button or **RIGHT** button when the menu is closed.
- Press the **UP** or **DOWN** button until **Settings** is highlighted. Press the **SET** or the **RIGHT** button to open the menu.
- Press the **UP** or **DOWN** button until **Units** is highlighted.
- Press the **SET** button to open the menu.
- Press the **UP** or **DOWN** button until **Consumption** is highlighted.
- Press the **RIGHT** or **LEFT** button to set the consumption unit.

7.27.55 Units Pressure

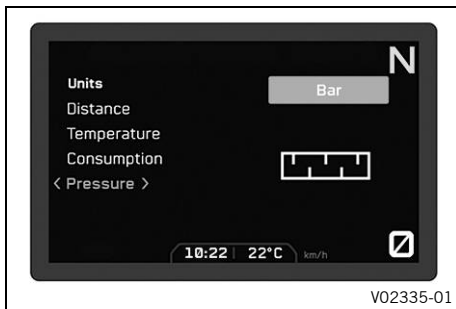

Condition

- The motorcycle is stationary.
- Press the **SET** button or **RIGHT** button when the menu is closed.
- Press the **UP** or **DOWN** button until **Settings** is highlighted. Press the **SET** or the **RIGHT** button to open the menu.
- Press the **UP** or **DOWN** button until **Units** is highlighted.
- Press the **SET** button to open the menu.
- Press the **UP** or **DOWN** button until **Pressure** is highlighted.
- Press the **RIGHT** or **LEFT** button to set the pressure unit.

7.27.56 Language



Condition

- The motorcycle is stationary.
- Press the **SET** button or **RIGHT** button when the menu is closed.
- Press the **UP** or **DOWN** button until **Settings** is highlighted. Press the **SET** or the **RIGHT** button to open the menu.
- Press the **UP** or **DOWN** button until **Language** is highlighted.
- Press the **RIGHT** or **LEFT** button to select the language.

The menu languages are US English, UK English, German, Italian, French, and Spanish.

7.27.57 Settings Heating



Condition

- The motorcycle is stationary.
- Press the **SET** button or **RIGHT** button when the menu is closed.
- Press the **UP** or **DOWN** button until **Settings** is highlighted. Press the **SET** or the **RIGHT** button to open the menu.
- Press the **UP** or **DOWN** button until **Heating** is highlighted.
- Press the **SET** button to open the menu.

The heated grip and the rider and passenger seat heating can be activated or deactivated in **Settings Heating**.

7.27.58 Settings Heating Grips



Condition

- The motorcycle is stationary.
- Press the **SET** button or **RIGHT** button when the menu is closed.
- Press the **UP** or **DOWN** button until **Settings** is highlighted. Press the **SET** or the **RIGHT** button to open the menu.
- Press the **UP** or **DOWN** button until **Heating** is highlighted.
- Press the **SET** button to open the menu.
- Press the **UP** or **DOWN** button until **Grips** is highlighted.
- Press the **RIGHT** or **LEFT** button to activate or deactivate the heated grips.

7.27.59 Settings Heating Rider Seat

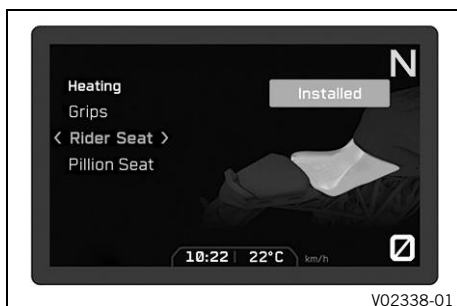

Condition

- Model with rider's seat heating.
- The motorcycle is stationary.
- Press the **SET** button or **RIGHT** button when the menu is closed.
- Press the **UP** or **DOWN** button until **Settings** is highlighted. Press the **SET** or the **RIGHT** button to open the menu.
- Press the **UP** or **DOWN** button until **Heating** is highlighted.
- Press the **SET** button to open the menu.
- Press the **UP** or **DOWN** button until **Rider Seat** is highlighted.
- Press the **RIGHT** or **LEFT** button to activate or deactivate the front rider's seat heating.

7.27.60 Settings Heating Pillion Seat



Condition

- Model with passenger seat heating.
- The motorcycle is stationary.
- Press the **SET** button or **RIGHT** button when the menu is closed.
- Press the **UP** or **DOWN** button until **Settings** is highlighted. Press the **SET** or the **RIGHT** button to open the menu.
- Press the **UP** or **DOWN** button until **Heating** is highlighted.
- Press the **SET** button to open the menu.
- Press the **UP** or **DOWN** button until **Pillion Seat** is highlighted.
- Press the **RIGHT** or **LEFT** button to activate or deactivate the passenger seat heating.

7.27.61 Extra Functions



Condition

- The motorcycle is stationary.
- Motorcycle with optional supplementary function.
 - Press the **SET** button or **RIGHT** button when the menu is closed.
 - Press the **UP** or **DOWN** button until **Settings** is highlighted. Press the **SET** or the **RIGHT** button to open the menu.
 - Press the **UP** or **DOWN** button until **Extra Functions** is highlighted.
 - Press the **SET** button to open the submenu.

Info

The optional extra functions are listed. The current **KTM PowerParts** and available software for your vehicle can be found on the KTM website.

7.27.62 Setting the time and date

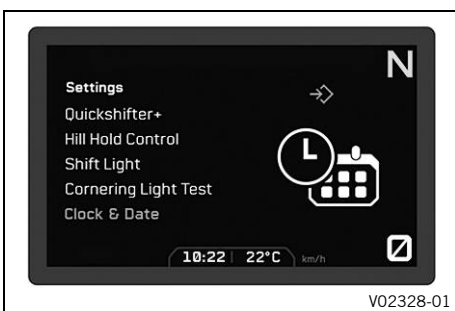

Condition

The motorcycle is stationary.

- Press the **SET** button or **RIGHT** button when the menu is closed.
- Press the **UP** or **DOWN** button until **Settings** is highlighted.
- Press the **RIGHT** or **SET** button to open the menu.
- Press the **UP** or **DOWN** button until **Clock & Date** is highlighted.
- Press the **SET** button to open the menu.

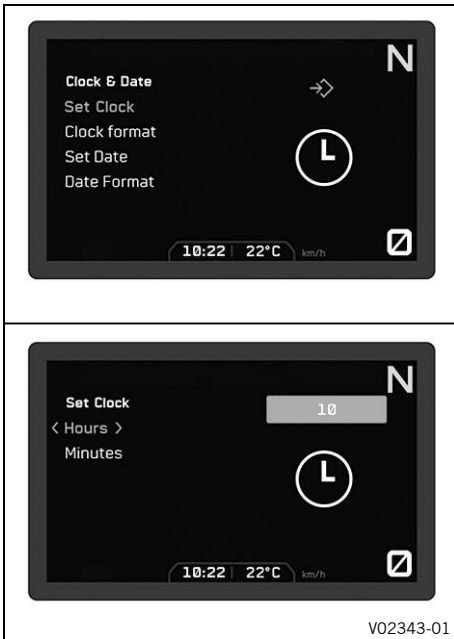

Setting the clock

- Press the **UP** or **DOWN** button until **Set Clock** is marked.
- Press the **SET** button to open the menu.
- Press the **UP** or **DOWN** button until **Hours** is highlighted.
- Press the **RIGHT** or **LEFT** button until the current hour is set.
- Press the **UP** or **DOWN** button until **Minutes** is highlighted.
- Press the **RIGHT** or **LEFT** button until the current minute is set.
- Press the **BACK** button to exit the menu.
- ✓ The time is stored.

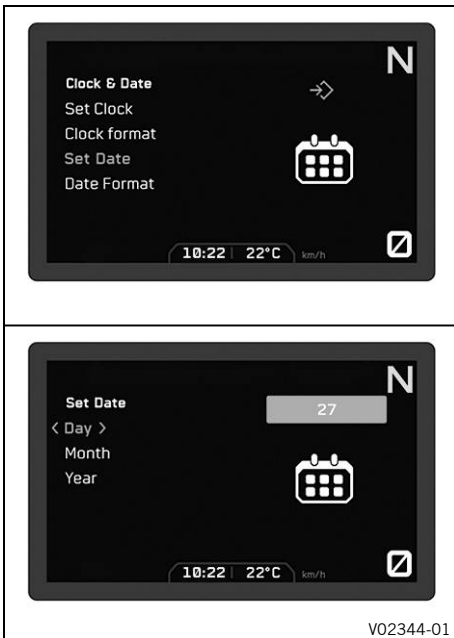

Setting the date

- Press the **UP** or **DOWN** button until **Set Date** is highlighted.
- Press the **SET** button to open the menu.
- Press the **UP** or **DOWN** button until **Day** is highlighted.
- Press the **RIGHT** or **LEFT** button until the current day is set.
- Press the **UP** or **DOWN** button until **Month** is highlighted.
- Press the **RIGHT** or **LEFT** button until the current month is set.
- Press the **UP** or **DOWN** button until **Year** is highlighted.
- Press the **RIGHT** or **LEFT** button until the current year is set.
- Press the **BACK** button to exit the menu.
- ✓ The date is stored.

8.1 Handlebar position

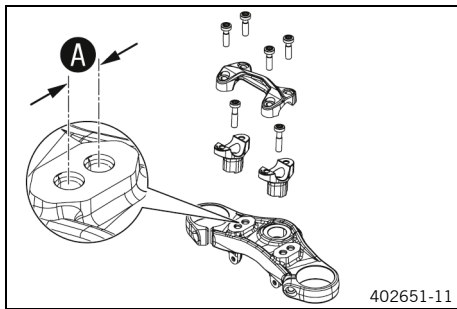

On the upper triple clamp there are two holes at a distance of **A** apart.

Hole distance A	15 mm (0.59 in)
------------------------	-----------------

The handlebar supports can be turned through 180°. The handlebar can be mounted in four different positions. In this way, the handlebar can be mounted in the most comfortable position for the rider.

8.2 Adjusting the handlebar position



Warning

Danger of accidents A repaired handlebar poses a safety risk.

If the handlebar is bent or straightened, the material becomes fatigued. The handlebar may break as a result.

- Change the handlebar if the handlebar is damaged or bent.

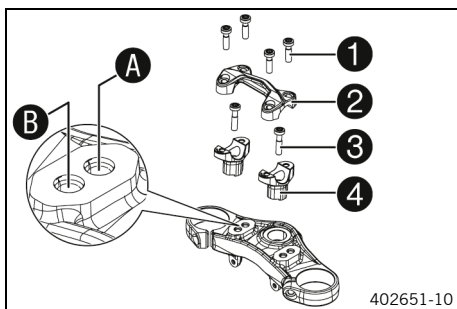

- Remove screws **1**. Take off handlebar clamp **2**. Take off handlebar and place it to the rear.



Info

Cover the components to protect them against damage. Do not kink the cables and lines.

- Remove screws **3**. Take off handlebar supports **4**.
- Position handlebar supports in the desired orientation above hole **A** or **B**.



Info

The handlebar supports are longer and higher on one side. Position the left and right handlebar supports evenly.

- Mount and tighten screws **3**.

Guideline

Screw, handlebar support	M10	40 Nm (29.5 lbf ft) Loctite®243™
--------------------------	-----	--

- Position the handlebar.



Info

Make sure the cables and wiring are positioned correctly.

- Position the handlebar clamp. Mount screws **1**, but do not tighten yet.
 - ✓ The lettering on the handlebar is in the middle of the handlebar clamp.
- First bolt the handlebar clamp with screws **1** onto the longer, higher side of the handlebar supports so that both parts touch.



- Tighten screws ① evenly.

Guideline

Screw, handlebar clamp	M8	20 Nm (14.8 lbf ft)
------------------------	----	---------------------

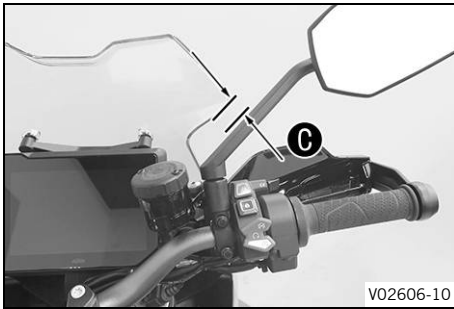

- Place on the vehicle and adjust both rear mirrors in a horizontal position.
- Check minimum spacing ① between the mirror bar and windshield after the handlebar has been driven in fully.

Guideline

Minimum spacing ① between the mirror bar and windshield	9 mm (0.35 in)
---	----------------

- » If the spacing ① between the mirror bar and windshield is below the minimum:
 - Adjust the steering angle. 🏍️ (p. 67)
- Make sure that there is sufficient space between the controls and fuel tank when the handlebar has been driven in fully after completing the work.



8.3 Adjusting the steering angle 🏍️

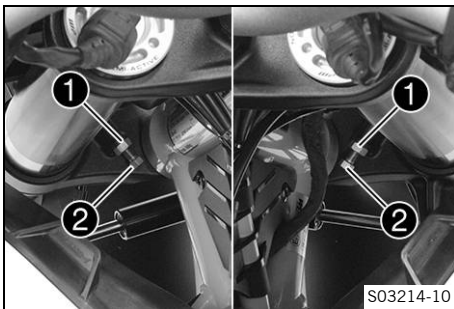

- Loosen nuts ①.
- Make sure that sufficient steering angle remains after finishing the work.

i Info
Do not unscrew screws fully.
The screw must be screwed in by at least five full turns.

- Adjust the steering angle by turning adjusting screws ② left and right.

Guideline

Minimum spacing between the mirror bar and windshield	9 mm (0.35 in)
---	----------------

Turn the adjusting screws ② so that the left and right steering angle settings are equal

- Tighten nuts ①.

Guideline

Remaining nuts, chassis	M8	25 Nm (18.4 lbf ft)
-------------------------	----	---------------------

- Make sure that there is sufficient space between the controls and fuel tank when the handlebar has been driven in fully after completing the work.



8.4 Adjusting the windshield

i Info
Do not make any adjustments while riding.

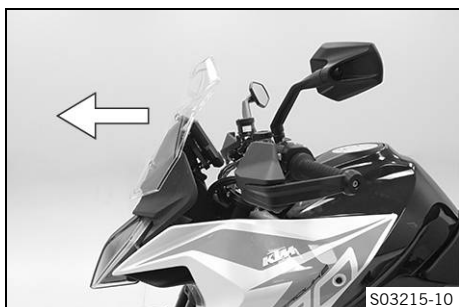

- Push windshield forwards.
- ✓ The windshield is unlocked.

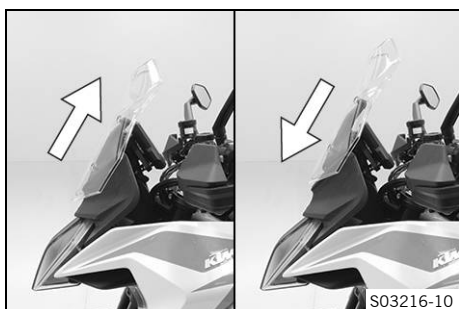

- To move the windshield to the desired position, push the windshield upward or downward.

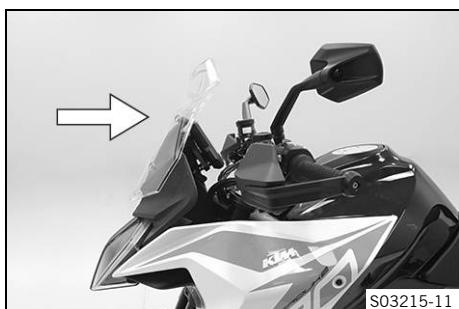

- Pull windshield back.
- ✓ The windshield is locked.

8.5 Adjusting the basic position of the clutch lever

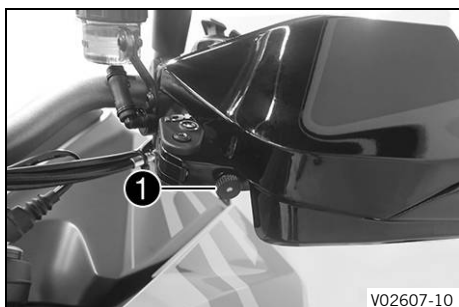

- Push clutch lever forward.
- Adjust basic position of the clutch lever to your hand size by turning adjusting screw ①.

i Info
Turn the adjusting screw clockwise to increase the distance between the clutch lever and the handlebar. Turn the adjusting screw counterclockwise to decrease the distance between the clutch lever and the handlebar.
The range of adjustment is limited.
Only turn the adjusting screw by hand, and do not use force.
Do not make any adjustments while riding.

8.6 Adjusting the basic position of the hand brake lever

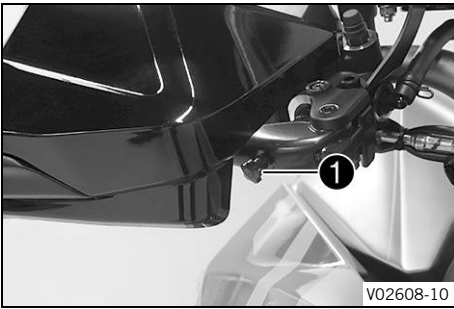

- Push hand brake lever forward.
- Adjust basic position of the hand brake lever to your hand size by turning adjusting screw ①.

i Info
 Turn the adjusting screw clockwise to increase the distance between the hand brake lever and the handlebar.
 Turn the adjusting screw counterclockwise to decrease the distance between the hand brake lever and the handlebar.
 The range of adjustment is limited.
 Only turn the adjusting screw by hand, and do not use force.
 Do not make any adjustments while riding.



8.7 Adjusting the basic position of the foot brake lever

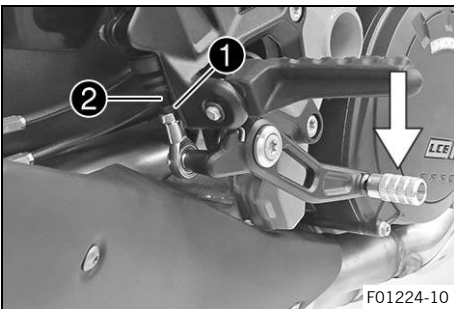

- Loosen nut ①.
- Press the foot brake lever down to be able to turn push rod ② more easily.
- Turn the push rod until the foot brake lever is in the desired position.

i Info
 The range of adjustment is limited.
 The screw must be screwed into the ball joint by at least five turns.

- Lock nut ①.



8.8 Setting the step plate of the foot brake lever

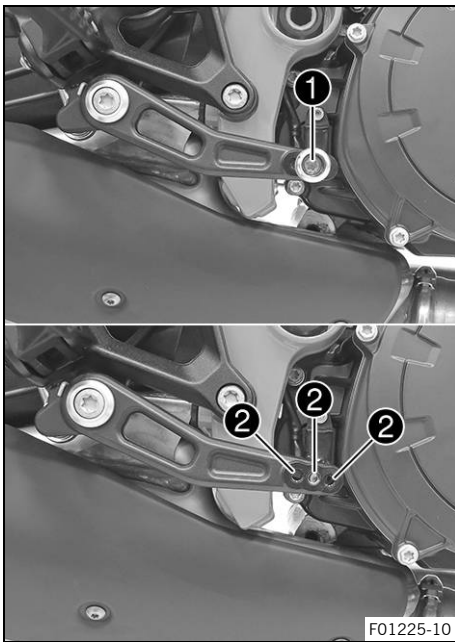

- Remove screw ① together with the step plate of the foot brake lever.
- To adjust the length of the foot brake lever, position the step plate of the foot brake lever using screw ① in a drill hole ②.

Standard	Middle hole
----------	-------------

- Tighten screw ①.

Guideline

Screw, step plate for foot brake lever	M6	10 Nm (7.4 lbf ft) Loctite®243™
--	----	---

8.9 Checking the basic position of the shift lever

i Info

When driving, the shift lever must not touch the rider's boot when in the basic position. If the shift lever is permanently touching the boot, the transmission will be subject to excessive load; this can cause a malfunction of the quickshifter.

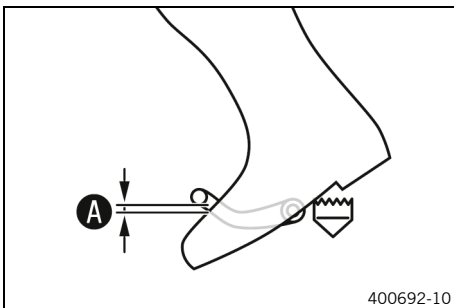

- Sit on the vehicle in the riding position and determine distance A between the upper edge of your boot and the shift lever.

Distance between shift lever and upper edge of boot	10 ... 20 mm (0.39 ... 0.79 in)
---	---------------------------------

- » If the distance does not meet specifications:
 - Set the basic position of the shift lever. 📖 (p. 70)

8.10 Adjusting the basic position of the shift lever 📖

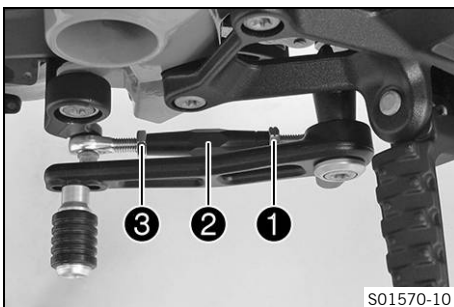

- Loosen nut ①, holding threaded rod ②.

i Info

Nut ① has a left-handed thread.

- Loosen nut ③, holding threaded rod ②.
- Turn threaded rod ② to adjust the shift lever.

i Info
 The range of adjustment is limited.
 The shift lever must not come into contact with any other vehicle components during the shift procedure.

- Tighten nut ③ while holding threaded rod ②.

Guideline

Nut, shift rod	M8	12 Nm (8.9 lbf ft)
----------------	----	--------------------

- Tighten nut ① while holding threaded rod ②.

Guideline

Nut, shift rod	M8LH	12 Nm (8.9 lbf ft)
----------------	------	--------------------



8.11 Setting the shift lever stub

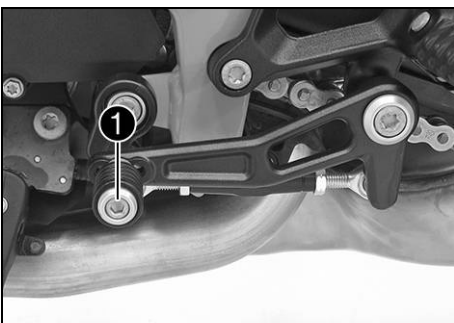

- Remove screw ① along with the shift lever stub.
- Position the shift lever stub with the screw in one of the drilled holes ② depending on the desired lever length.

Guideline

Standard	Middle hole
----------	-------------

- Tighten the screw.

Guideline

Screw, shift lever stub	M6	10 Nm (7.4 lbf ft) Loctite®243™
-------------------------	----	---

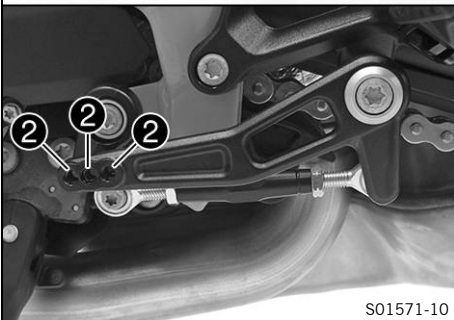

S01571-10

9.1 Advice on preparing for first use



Danger

Danger of accidents A rider who is not fit to ride poses a danger to him or herself and others.

- Do not operate the vehicle if you are not fit to ride due to alcohol, drugs or medication.
- Do not operate the vehicle if you are physically or mentally impaired.



Warning

Risk of injury Missing or poor protective clothing presents an increased safety risk.

- Wear appropriate protective clothing such as helmet, boots, gloves as well as trousers and a jacket with protectors on all rides.
- Always wear protective clothing that is in good condition and meets the legal regulations.



Warning

Danger of crashing Different tire tread patterns on the front and rear wheel impair the handling characteristic.

Different tire tread patterns can make the vehicle significantly more difficult to control.

- Make sure that only tires with a similar tire tread pattern are fitted to the front and rear wheel.



Warning

Danger of accidents Non-approved or non-recommended tires and wheels impact the handling characteristic.

- Only use tires/wheels approved by KTM with the corresponding speed index.



Warning

Danger of accidents New tires have reduced road grip.

The contact surface on new tires is not yet roughened.

- Run in new tires with moderate riding at alternating angles.
Running-in phase 200 km (124 mi)



Warning

Danger of accidents The brake system fails in the event of overheating.

If the foot brake lever is not released, the brake linings drag continuously.

- Take your foot off the foot brake lever if you do not want to brake.



Info

When using your vehicle, remember that others may feel disturbed by excessive noise.

- Make sure that the pre-sales inspection work has been carried out by an authorized KTM workshop.
 - ✓ You will receive a delivery certificate when the vehicle is handed over.
- Before riding for the first time, read the entire Owner's Manual carefully.
- Get to know the controls.
- Adjust the motorcycle to your requirements, as described in the "Ergonomics" chapter.
- Get used to the handling characteristic of the motorcycle in a suitable area before making a longer trip. Try also to ride as slowly as possible to get a better feel for the motorcycle.
- Hold the handlebar firmly with both hands and keep your feet on the footrests when riding.
- Run the engine in.

9.2 Running in the engine

- During the running-in phase, do not exceed the specified engine speed.

Guideline

Maximum engine speed	
During the first: 1,000 km (620 mi)	6,500 rpm
After the first: 1,000 km (620 mi)	10,500 rpm



Tip

During the running-in phase, set the shift warning light to the specified engine speed.

- Avoid fully opening the throttle!



9.3 Loading the vehicle



Warning

Danger of accidents Total weight and axle loads influence the handling characteristic.

The total weight consists of: motorcycle ready for operation and with a full tank, driver and passenger with protective clothing and helmet, and luggage.

- Do not exceed the maximum permissible overall weight or the axle loads.



Warning

Danger of accidents Improper mounting of cases or the tank rucksack impairs the handling characteristic.

- Mount and secure cases and tank rucksack according to the manufacturer's instructions.



Warning

Danger of accidents Carrying luggage alters handling characteristics at high speed.

- Adapt your speed to your payload.
 - Ride more slowly if your motorcycle is loaded with cases or other luggage.
- Maximum speed with luggage 130 km/h (80.8 mph)



Warning

Danger of accidents Overloading will destroy the baggage system.

- Observe the manufacturer's instructions on the maximum payload if you have panniers mounted to your motorcycle.



Warning

Danger of accidents Luggage which has slipped impairs visibility.

If the tail light is covered, you are less visible to traffic behind you, especially when it is dark.

- Check that your luggage is fixed properly at regular intervals.



Warning

Danger of accidents A high payload alters the handling characteristic and increases the stopping distance.

- Adapt your speed to your payload.

9 PREPARING FOR USE



Warning

Danger of accidents Pieces of luggage which have slipped impair the handling characteristic.

- Check that your luggage is fixed properly at regular intervals.



Warning

Fire hazard The hot exhaust system may burn luggage.

- Fasten your luggage in such a way that it cannot be burned or singed by the hot exhaust system.

- If luggage is carried, ensure it is fixed firmly as close as possible to the center of the vehicle and ensure even weight distribution between the front and rear wheels.
- Do not exceed the maximum permissible weight and maximum permissible axle loads.

Guideline

Maximum permissible overall weight	456 kg (1,005 lb.)
Maximum permissible front axle load	165 kg (364 lb.)
Maximum permissible rear axle load	320 kg (705 lb.)

10.1 Checks and maintenance measures when preparing for use

i Info

Before every trip, check the condition of the vehicle and ensure that it is roadworthy. The vehicle must be in perfect technical condition when it is being operated.

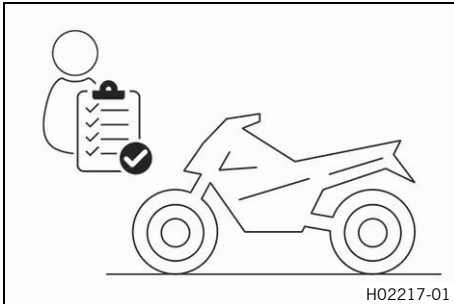

- Check the engine oil level. (📖 p. 136)
- Check front brake fluid level. (📖 p. 105)
- Check rear brake fluid level. (📖 p. 108)
- Check the front brake linings. (📖 p. 107)
- Check the brake linings of the rear brake. (📖 p. 109)
- Check that the brake system is functioning properly.
- Check coolant level in the compensating tank. (📖 p. 132)
- Check the chain for dirt. (📖 p. 94)
- Check the chain tension. (📖 p. 95)
- Check tire condition. (📖 p. 115)
- Check tire pressure. (📖 p. 116)
- Check the settings of all controls and ensure that they can be operated smoothly.
- Check that the electrical system is functioning properly.
- Check that luggage is properly secured.
- Check the setting of the rear mirror.
- Check the fuel level.

10.2 Starting the vehicle



Danger

Danger of poisoning Exhaust gases are toxic and inhaling them may result in unconsciousness and death.

- Always make sure there is sufficient ventilation when running the engine.
- Use effective exhaust extraction when starting or running the engine in an enclosed space.



Caution

Danger of accidents Electronic components and safety devices will be damaged if the 12-V battery is discharged or missing.

If the 12-V battery is discharged or defective, malfunctions in the vehicle electronics can occur, especially when starting.

- Never operate the vehicle with a discharged 12-V battery or without a 12-V battery.

Note

Engine damage High revving speed with a cold engine negatively impacts the lifespan of the engine.

- Always run the engine warm at a low speed.

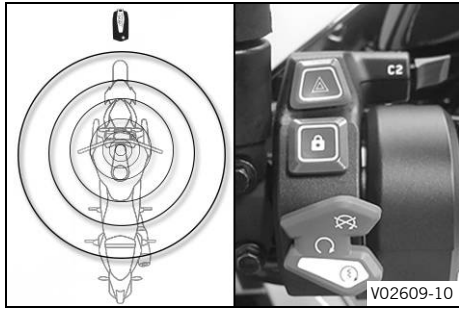

- Take the motorcycle off the side stand and sit on the motorcycle.
- Move the RACE-ON button within the range of the steering lock.
- Ensure that the RACE ON key stays in range while riding.

Guideline

Maximum range of the RACE-ON key around the steering lock	1.5 m (4.9 ft)
---	----------------



Info

The range may be reduced by decreases in RACE ON key battery voltage and by interfering radio waves. If the battery voltage of the RACE-ON key is too low, one of the ignition keys must be placed in the area of the steering lock (p. 22) and must be safely stored again after starting.

- Make sure that the start button/emergency OFF switch is in the middle position ○.
- Switch on ignition; to do this, briefly press the RACE-ON button (maximum of 1 second).

Guideline

To avoid malfunctions in the control unit communication, do not switch the ignition off and on in rapid succession.

- ✓ The steering is unlocked.
- ✓ The function check of the combination instrument is run.
- ✓ The ABS warning lamp goes out when starting off.



Info

If the steering does not unlock, move the handlebar slightly.

- Shift the transmission into neutral **N**.
- ✓ The green idle indicator lamp **N** lights up.
- Press the start button/emergency OFF switch into the lower position (Ⓢ).



Info

Only press the start button/emergency OFF switch into the lower position (Ⓢ) when the combination instrument function check has been completed. Do not open the throttle to start. If the starting attempt is unsuccessful, wait for 15 seconds before making another attempt at starting. After 6 unsuccessful starting attempts, do not try again, and check the vehicle for other faults instead. This motorcycle is equipped with a safety starting system. You can only start the engine if the transmission is in neutral or if the clutch lever is pulled when a gear is engaged. If the side stand is folded out and you shift into gear, the engine stops.

10.3 Launch Control (optional)

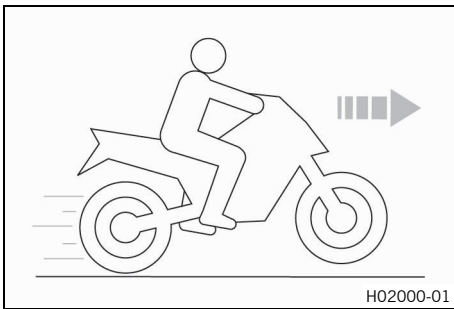

Launch Control is an optional vehicle electronics function. Launch control adjusts the engine speed in order to achieve the best possible acceleration. Launch control can be used for starting off for a maximum of three times in succession. Launch control is temporarily deactivated after the third starting off in order to protect the engine, transmission and cooling system from overloading. Launch control is also deactivated if all conditions for activation are no longer met. Launch control is enabled again in the following cases: the engine runs for at least three minutes, the engine is switched off for 20 minutes or a distance of 1.5 km (0.93 mi) has been covered.

10.4 Starting off

- Pull the clutch lever, shift into first gear, release the clutch lever slowly and at the same time open the throttle gently.

10.5 Starting off with launch control (optional)



Warning

Danger of accidents Launch control enables very powerful acceleration which may ask too much of a novice rider.

- Only use the launch control if you have the appropriate experience.
- Do not use launch control on public roads.

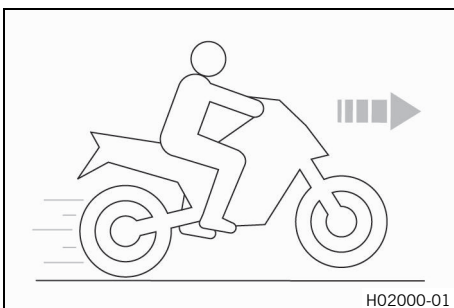

Condition

The **Track** riding mode (optional) is activated.

First gear is engaged.

The TC indicator lamp does not light up.

Coolant temperature: > 60 °C (> 140 °F)

Total riding distance covered: > 1,000 km (> 620 mi)

- Activate launch control in the combination instrument.
 - ✓ The number of available starts is indicated on the start screen.
- Apply full throttle with the clutch lever pulled.
 - ✓ The engine speed is adjusted.

6,500 rpm
 - ✓ The TC indicator lamp flashes quickly.
- Release clutch lever quickly but in a controlled manner.

10.6 Start off with HHC (Option: Hill-start assist)

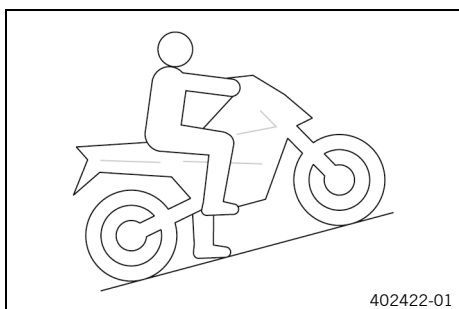

The **HHC** is an optional auxiliary function of the brake system. The **HHC** prevents accidental rolling back of the motorcycle on hills.

The **HHC** recognizes stopping on hills and operates the rear brake. After releasing the brake lever, the brake force is maintained for a maximum of 5 seconds as long as the motorcycle is not moving forward.

When driving off the **HHC** releases the rear brake automatically.

i Info

When the **HHC** is active, the TC indicator lamp  flashes. When the ignition is switched on, the **HHC** can still be active, even if the engine is stopped.

To roll back with active **HHC**, wait 5 seconds, shift to neutral, or switch off the ignition.

If the **HHC** does not detect a start off after 5 seconds, the braking force is automatically reduced gently.

When a brake lever is actuated, the **HHC** is re-activated.

10.7 Anti wheelie mode (optional)



The **Anti Wheelie Mode** is an optional vehicle electronics function. Anti wheelie mode is intended to prevent the front wheel rising when accelerating.

10.8 Quickshifter + (optional)

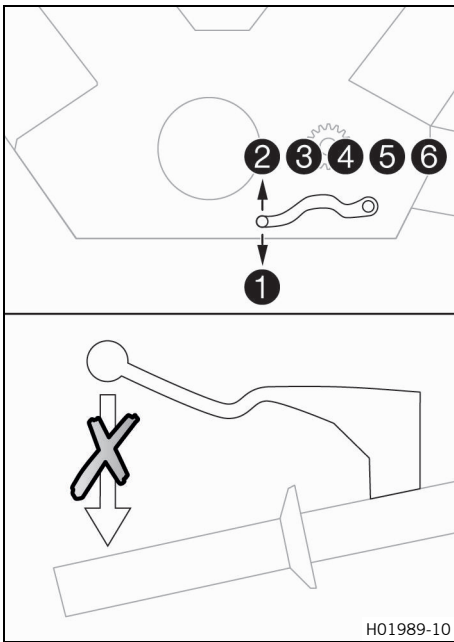

If the quickshifter + (optional) is activated, you can shift up and down without actuating the clutch. Because there is no need to close the throttle grip, uninterrupted gear shifts are possible. The quickshifter + uses the shifter shaft position to check whether or not a shift should be initiated, and sends a corresponding signal to the engine control. If the quickshifter + is disabled in the combination instrument, the clutch needs to be actuated in the normal way for each shift.

10.9 Shifting, riding



Warning

Danger of accidents Abrupt load alterations can cause the vehicle to get out of control.

- Avoid abrupt load alterations and sudden braking actions.
- Adapt your speed to the road conditions.



Warning

Danger of accidents If you change down at high engine speed, the rear wheel blocks and the engine races.

- Do not change into a low gear at high engine speed.



Warning

Danger of accidents Adjustments to the vehicle distract attention from traffic activity.

- Make all adjustments when the vehicle is at a standstill.



Warning

Risk of injury The passenger may fall from the motorcycle if they conduct themselves incorrectly.

- Ensure that the passenger sits correctly on the passenger seat, places his or her feet on the passenger foot pegs and holds on to the rider or the grab handles.
- Note the regulations governing the minimum age of passengers in your country.



Warning

Danger of accidents A risky riding style constitutes a major risk.

- Comply with traffic regulations and ride defensively and with foresight to detect sources of danger as early as possible.



Warning

Danger of accidents Cold tires have reduced road grip.

- Ride the first miles carefully on every journey at moderate speed until the tires reach operating temperature.



Warning

Danger of accidents New tires have reduced road grip.

The contact surface on new tires is not yet roughened.

- Run in new tires with moderate riding at alternating angles.
Running-in phase 200 km (124 mi)



Warning

Danger of accidents Total weight and axle loads influence the handling characteristic.

The total weight consists of: motorcycle ready for operation and with a full tank, driver and passenger with protective clothing and helmet, and luggage.

- Do not exceed the maximum permissible overall weight or the axle loads.



Warning

Danger of accidents Pieces of luggage which have slipped impair the handling characteristic.

- Check that your luggage is fixed properly at regular intervals.



Warning

Danger of accidents A fall can damage the vehicle more seriously than it may first appear.

- Check the vehicle after a fall as you do when preparing for use.

Note

Engine damage Unfiltered intake air has a negative effect on the service life of the engine. Dust and dirt will enter the engine without an air filter.

- Only operate the vehicle if it is equipped with an air filter.

Note

Engine failure Overheating damages the engine.

- If the coolant temperature warning is displayed, stop immediately and take care not to endanger yourself or other traffic participants in the process.
- Allow the engine and cooling system to cool down.
- Check and, if necessary, correct the coolant level on the cooling system while it is in a cooled state.

Note

Transmission damage Incorrect use of Easy Shift will damage the transmission.

Easy Shift can only be used if the function is activated in the combination instrument.

Easy Shift is not active if you pull the clutch lever.

- Only use Easy Shift in the permitted speed range shown.



Info

If you hear unusual noises while riding, stop immediately, switch off the engine, and contact an authorized KTM workshop.

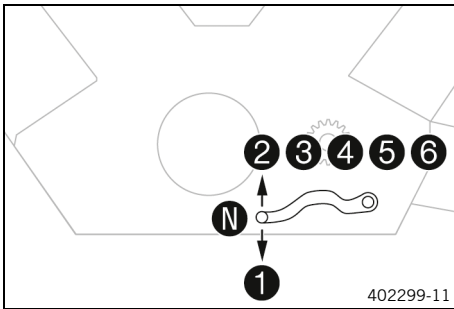



- Shift into a higher gear when conditions allow (incline, road situation, etc.).
- Release the throttle while simultaneously pulling the clutch lever, shift into the next gear, release the clutch lever, and open the throttle.



Info

The gear positions can be seen in the figure. The idle position is between the first and second gears. First gear is used for starting off or for steep inclines.

- After reaching maximum speed by fully opening the throttle grip, turn the throttle back so it is $\frac{3}{4}$ open. This will barely reduce the speed, but fuel consumption will be considerably lower.
- Accelerate only up to a speed suitable for the road surface and weather conditions. Particularly in bends, do not shift, and accelerate very carefully.
- Brake if necessary and close the throttle at the same time in order to shift down.
- Pull clutch lever and shift into a lower gear, release the clutch lever slowly, and open the throttle or shift again.
- If the engine stalls (e.g. at a crossroads), just pull clutch lever and press the start button/emergency OFF switch into the lower position (3). The transmission must not be shifted into neutral.
- Switch off the engine if you are likely to be running at idle speed or stationary for a long time.
- If the oil pressure warning lamp  lights up during a trip, stop as soon as it is safe to do so and switch off the engine. Contact an authorized KTM workshop.
- If the malfunction indicator lamp  lights up during a trip, please contact an authorized KTM workshop as soon as possible.
- If the general warning lamp  lights up during a trip, the display shows a message for 10 seconds.



Info

Very important messages are stored in the **Warning** menu.

- If the ice warning appears in the combination instrument, the roads may be icy. Adjust your speed to the road conditions.

Condition

The quickshifter + (optional) is enabled.

- If the quickshifter + is enabled in the combination instrument, one can shift up in the engine speed range shown without pulling the clutch lever.

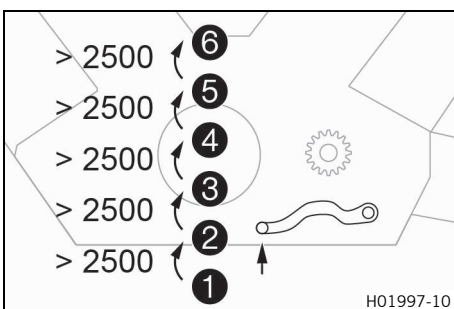

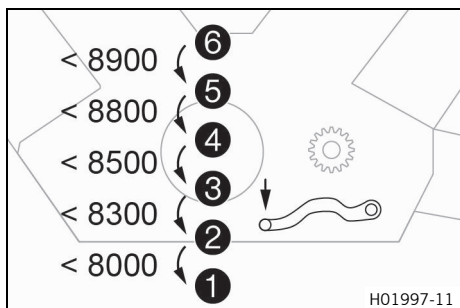

i Info
The minimum engine speed before shifting up in revolutions per minute is shown in the figure. Pull the shift lever to the stop quickly without changing the throttle twist grip position.

- If the quickshifter + is enabled in the combination instrument, one can shift down in the engine speed range shown without pulling the clutch lever.

i Info
The maximum engine speed before shifting down in revolutions per minute is shown in the figure. Depress the shift lever to the stop quickly without changing the throttle twist grip position.

10.10 MSR (optional)

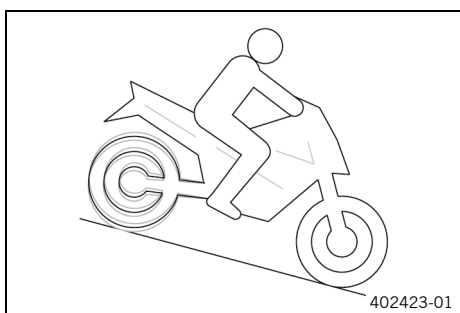

The **MSR** is an optional auxiliary function of the engine control. If the engine braking effect is too great, the **MSR** prevents the rear wheel from locking or sliding away on a sloping position. To avoid slip of the rear wheel, the **MSR** only opens the throttle valve as far as absolutely necessary. The **MSR** is applied on surfaces, where the friction coefficient is too low to open the slipper clutch. To further increase ride safety, the **MSR** is slope dependent.

i Info
When the cornering **MTC** is switched off or ABS mode **Supermoto** is active, the **MSR** is not active.

10.11 Applying the brakes

! Warning
Danger of accidents Moisture and dirt impair the brake system.
- Brake carefully several times to dry out and remove dirt from the brake linings and the brake discs.

! Warning
Danger of accidents A spongy pressure point on the front or rear brake reduces braking efficiency.
- Check the brake system and do not continue riding until the problem is eliminated. (Your authorized KTM workshop will be glad to help.)

! Warning
Danger of accidents The brake system fails in the event of overheating. If the foot brake lever is not released, the brake linings drag continuously.
- Take your foot off the foot brake lever if you do not want to brake.

! Warning
Danger of accidents Higher total weight increases the stopping distance.
- Take the longer stopping distance into account when carrying a passenger or luggage with you.



Warning

Danger of accidents Salt on the roads impairs the brake system.

- Brake carefully several times to remove salt from the brake linings and the brake discs.



Warning

Danger of accidents ABS may increase the stopping distance in certain situations.

- Adjust application of the brakes to the respective riding situation and riding surface conditions.



Warning

Danger of accidents Excessively forceful application of the brakes blocks the wheels.

The ABS effectiveness is only ensured if it is switched on.

- Leave the ABS switched on in order to benefit from the protective effect.



Warning

Danger of accidents Driving aids can reduce the probability of a fall only within physical limits.

It is not always possible to compensate for extreme riding situations, for example with luggage loaded with a high center of gravity, varying road surfaces, steep descents or full braking without disengaging the gear.

- Adapt your riding style to the road conditions and your driving ability.

- When braking, release the throttle and apply the front and rear brakes at the same time.



Info

When the ABS is enabled, you can achieve maximum braking power even on low grip surfaces such as sandy, wet, or slippery terrain without locking of the wheels.



Warning

Danger of accidents The rear wheel can lock due to the engine braking effect.

- Pull in the clutch, if you perform emergency or full braking, or if you brake on a slippery ground.



Warning

Danger of accidents Banked or laterally sloping ground reduces the maximum possible delay.

- If possible finish braking before going into a bend.

- Always finish braking before you go into a bend. Change down to a lower gear appropriate to your road speed.
- Use the braking effect of the engine on long downhill stretches. Change down one or two gears, but do not over-rev the engine. In this way, you have to brake far less and the brakes do not overheat.



10.12 Stopping, parking



Warning

Risk of injury People who act without authorization endanger themselves and others.

If a valid transponder is in range, the vehicle can be started.

- Do not leave the vehicle unattended if the engine is running.
- Never leave the vehicle unattended if the RACE-ON key or the black ignition key are close to the vehicle.
- Protect the vehicle against access by unauthorized persons.
- Lock the steering if you leave the vehicle unattended.



Warning

Danger of burns Some vehicle components become very hot when the vehicle is operated.

- Do not touch any parts such as the exhaust system, radiator, engine, shock absorber, or brake system before the vehicle parts have cooled down.
- Let the vehicle parts cool down before you perform any work on the vehicle.

Note

Material damage The vehicle may be damaged by incorrect procedure when parking.

Significant damage may be caused if the vehicle rolls away or falls over.

The components for parking the vehicle are designed only for the weight of the vehicle.

- Park the vehicle on a firm and level surface.
- Ensure that nobody sits on the vehicle when the vehicle is parked on a stand.

Note

Fire hazard Hot vehicle components pose a fire hazard and explosion risk.

- Do not park the vehicle near to materials which are highly flammable or explosive.
- Allow the vehicle to cool down before covering it.

-
- Apply the brakes on the motorcycle.
 - Shift the transmission into neutral **N**.
 - Switch off ignition – to do this, briefly press the RACE-ON button  (maximum of 1 second) with the ignition switched on.



Info

If the engine is switched off with the emergency OFF switch and the ignition remains switched on using the RACE-ON button, the power supply to most electrical power consumers remains uninterrupted. This discharges the 12-V battery. You should therefore always switch off the engine with the RACE-ON button – the emergency OFF switch is intended for emergencies only.

-
- Park the motorcycle on a firm surface.
 - Swing side stand forward with your foot as far as it will go and lean the vehicle on it.
 - Move handlebar fully to the left and press and hold the RACE-ON button  (for at least 2 seconds).
 - ✓ The steering is locked.



Info

If the steering lock does not engage, move the handlebar slightly.

10.13 Transporting

Note

Danger of damage The parked vehicle can roll away or fall over.

- Park the vehicle on a firm and level surface.

Note

Fire hazard Hot vehicle components pose a fire hazard and explosion risk.

- Do not park the vehicle near to materials which are highly flammable or explosive.
- Allow the vehicle to cool down before covering it.

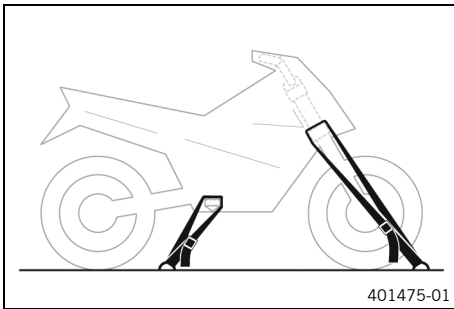

- Switch off the engine.
- Use tension belts or other suitable devices to secure the motorcycle against falling over or rolling away.

10.14 Towing in the event of a breakdown

Note

Danger of damage Towing away using a towing vehicle is not an appropriate vehicle recovery method. Damage to the drive train or transmission may occur during towing.

- Do not use towing equipment where the wheels of the broken down vehicle remain on the road and rotate as it is towed.
- Always transport a broken down vehicle on a trailer or on the loading area of a transport vehicle.

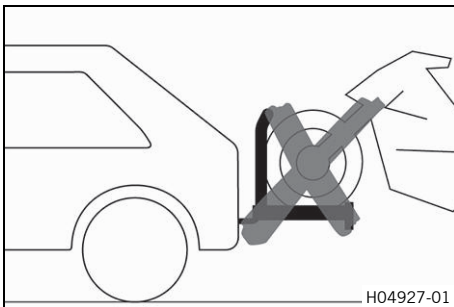

- Ensure that the broken down vehicle is properly secured on the trailer or transport vehicle.
- Observe local regulations for the recovery of broken down vehicles.

10.15 Refueling



Danger

Fire hazard Fuel is highly flammable.

The fuel in the fuel tank expands when warm and can escape if overfilled.

- Do not fuel the vehicle in the vicinity of open flames or lit cigarettes.
- Switch off the engine for refueling.
- Make sure that no fuel is spilled; particularly not on hot parts of the vehicle.
- If any fuel is spilled, wipe it off immediately.
- Observe the specifications for refueling.



Warning

Danger of poisoning Fuel is poisonous and a health hazard.

- Avoid skin, eye and clothing contact with fuel.
- Immediately consult a doctor if you swallow fuel.
- Do not inhale fuel vapors.
- In case of skin contact, rinse the affected area with plenty of water.
- Rinse the eyes thoroughly with water, and consult a doctor in case of fuel contact with the eyes.
- Change your clothing in case of fuel spills on them.

Note

Material damage Inadequate fuel quality causes the fuel filter to quickly become clogged.

In some countries and regions, the available fuel quality and cleanliness may not be sufficient. This will result in problems with the fuel system.

- Refuel only with clean fuel that meets the specified standards. (Your authorized KTM workshop will be glad to help.)



Note

Environmental hazard Improper handling of fuel is a danger to the environment.

- Do not allow fuel to enter the groundwater, the soil, or the sewage system.

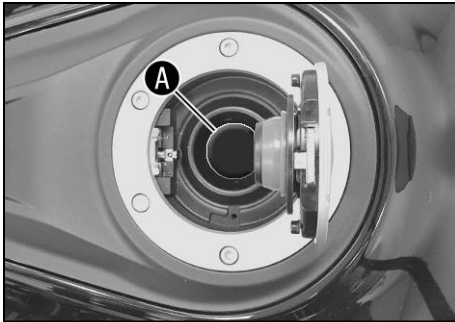

- Switch off the engine.
- Open fuel tank filler cap. (📖 p. 25)
- Fill the fuel tank with fuel up to the lower edge **A** of the filler neck.

Total fuel tank capacity, approx.	23 l (6.1 US gal)	Super unleaded (ROZ 95) (📖 p. 162)
-----------------------------------	----------------------	--

- Close fuel tank filler cap. (📖 p. 26)



S03211-10

11.1 Additional information

Any further work that results from the compulsory work or from the recommended work must be ordered separately and invoiced separately.

Different service intervals may apply in your country, depending on the local operating conditions.

Individual service intervals and scopes may change in the course of technical developments. The most up-to-date service schedule can always be found on KTM Dealer.net. Your authorized KTM dealer will be happy to advise you.

11.2 Required work

	every 24 months	every 12 months	every 30,000 km (18,600 mi)	every 15,000 km (9,300 mi)	after 1,000 km (620 mi)
Read out the fault memory using the KTM diagnostics tool. 🛠️	○	●	●	●	●
Check the exhaust valve control unit with the KTM diagnostics tool. 🛠️		●	●	●	●
Program the shift shaft sensor. 🛠️	○	●	●	●	●
Check that the electrical system is functioning properly.	○	●	●	●	●
Change the engine oil and the oil filter, clean the oil screens. 🛠️ (📖 p. 136)	○	●	●	●	●
Check the front brake linings. (📖 p. 107)	○	●	●	●	●
Check the brake linings of the rear brake. (📖 p. 109)	○	●	●	●	●
Check the brake discs. (📖 p. 105)	○	●	●	●	●
Check the brake lines for damage and tightness.	○	●	●	●	●
Change the front brake fluid. 🛠️					●
Change the rear brake fluid. 🛠️					●
Change the hydraulic clutch fluid. 🛠️					●
Check front brake fluid level. (📖 p. 105)	○	●	●	●	
Check rear brake fluid level. (📖 p. 108)	○	●	●	●	
Check/correct the fluid level of the hydraulic clutch. (📖 p. 99)		●	●	●	
Check the shock absorber and fork for leaks. Perform service as needed and depending on how the vehicle is used. 🛠️	○	●	●	●	●
Clean dust boots of the fork legs. 🛠️ (📖 p. 102)		●	●		
Check the steering head bearing for play. 🛠️	○	●	●	●	●
Check tire condition. (📖 p. 115)	○	●	●	●	●
Check tire pressure. (📖 p. 116)	○	●	●	●	●
Check chain, rear sprocket, engine sprocket, and chain guide. (📖 p. 97)		●	●	●	●
Check the chain tension. (📖 p. 95)	○	●	●	●	●
Measure the wheel bearing play and grease the rear hub. 🛠️			●		
Check that the rear wheel nut (right side) is tightened to the specified torque. 🛠️	○	●	●	●	●
Change the spark plugs. (Air filter removed). 🛠️			●		
Check the valve clearance (air filter and spark plugs removed). 🛠️			●		
Change the SAS diaphragm valves. 🛠️			●		
Check the cables for damage and routing without sharp bends (fuel tank removed). 🛠️		●	●	●	●
Check coolant level in the compensating tank. (📖 p. 132)	○	●	●	●	●
Change the air filter, clean the air filter box. 🛠️		●	●		
Check the fuel pressure. 🛠️		●	●	●	●

	every 24 months				
	every 12 months				
	every 30,000 km (18,600 mi)				
	every 15,000 km (9,300 mi)				
	after 1,000 km (620 mi)				
Check setting of the lighting system. (🔧 p. 127)	○	●	●		
Check that the radiator fan is functioning properly. 🛠️	○	●	●	●	●
Final check: Check the vehicle is roadworthy and take a test ride. 🛠️	○	●	●	●	●
Read out the error memory after the test ride using the KTM diagnostics tool. 🛠️	○	●	●	●	●
Reset the service display using the KTM diagnostic tool. 🛠️	○	●	●	●	●
Make a service entry in KTM Dealer.net . 🛠️	○	●	●	●	●

- One-time interval
- Periodic interval

11.3 Recommended work

	every 48 months				
	every 12 months				
	every 30,000 km (18,600 mi)				
	every 15,000 km (9,300 mi)				
	after 1,000 km (620 mi)				
Check the frame. 🛠️				●	
Check the link fork. 🛠️				●	
Check/clean the oil nozzle for clutch lubrication. 🛠️	○	●	●		
Check the fork bearing. 🛠️		●	●		
Check the wheel bearings. 🛠️		●	●		
Clean the drain hole of the shock absorber support. 🛠️		●	●	●	●
Grease all moving parts (e.g. side stand, hand lever, chain, etc.) and check for smooth operation. 🛠️	○	●	●	●	●
Empty the drainage hoses. 🛠️	○	●	●	●	●
Check all hoses (e.g. fuel, cooling, bleeder, drainage hoses, etc.) and sleeves for cracking, tightness, and correct routing. 🛠️		●	●	●	●
Check the tightness of the safety-relevant screws and nuts which are easily accessible. 🛠️	○	●	●	●	●
Check the antifreeze. 🛠️	○	●	●	●	
Change the coolant. 🛠️					●

- One-time interval
- Periodic interval

12.1 Fork/shock absorber

Semi-active suspension **WP Semi-active Suspension** can be used to tune the suspension individually without the use of tools.

Electronic suspension setting **WP Semi-active Suspension** constantly regulates the damping behavior of the suspension taking into account various sensor data.

As a result, the electronic damping valves are matched to the current driving situation and terrain characteristics as well as the settings made by the rider in the **"Load"** and **"Damping"** menu.

Always adapt the suspension to your riding style and the payload.

In the **"Load"** menu, the suspension can be set to the payload.

In the **"Damping"** menu, the damping behavior of the suspension can be set.

12.2 "Load"



Tunings for different payloads can be selected in the **"Load"** menu. A selection can be made between one-person operation, one-person operation with luggage, two-person operation, and two-person operation with luggage.

The payload selected last is displayed on the right in the segment display.

i Info

For the setting to be accepted by the motorcycle, the motorcycle must be stationary and unloaded, and the engine must be running.

The symbol of the last payload flashes until the new setting is adopted.

12.3 "Damping"



Possible states

- Sport – Tight tuning of the suspension components with very direct feedback from the chassis
- Street – Normal tuning of the suspension components with direct feedback from the chassis
- Comfort – Soft tuning of the suspension components with good feedback from the chassis

Various tunings for the damping of the suspension components can be selected in the **"Damping"** menu. You can choose between **"Sport"**, **"Street"** and **"Comfort"**.

i Info

If the setting for **"Ride Mod"** is changed, the relevant setting for **"Damping"** will change at the same time.

13.1 Raising the motorcycle with the rear lifting gear

Note

Danger of damage The parked vehicle can roll away or fall over.

- Park the vehicle on a firm and level surface.

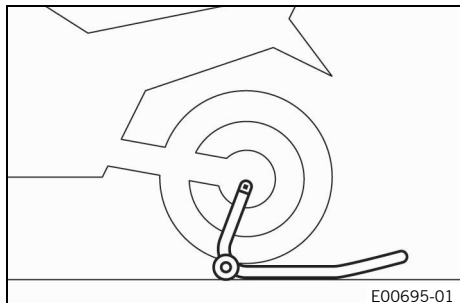

- Insert the adapter in the rear lifting gear.

Rear wheel work stand for single-sided swing arm
(61329955000)

- Position the motorcycle upright, place the lifting gear in the axle, and raise the motorcycle.

13.2 Removing the rear of motorcycle from the lifting gear

Note

Danger of damage The parked vehicle can roll away or fall over.

- Park the vehicle on a firm and level surface.

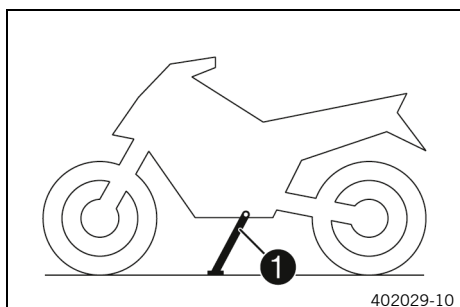

- Secure the motorcycle against falling over.
- Remove the rear wheel stand and lean the vehicle on side stand ①.

13.3 Lifting the motorcycle with the front lifting gear

Note

Danger of damage The parked vehicle can roll away or fall over.

- Park the vehicle on a firm and level surface.

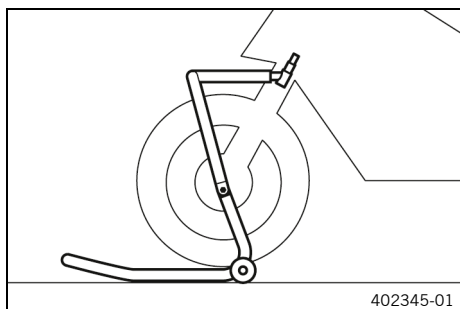

Preparatory work

- Raise the motorcycle with the rear lifting gear. (📖 p. 90)

Main work

- Move the handlebar to the straight-ahead position.
- Position front lifting gear with adapter.

Mounting pin (69329965040)

Front wheel work stand, large (69329965100)

- Align the front lifting gear with the fork legs.



Info

Always raise the motorcycle at the rear first.

- Lift the motorcycle at the front.



13.4 Taking the motorcycle off the front lifting gear

Note

Danger of damage The parked vehicle can roll away or fall over.

- Park the vehicle on a firm and level surface.

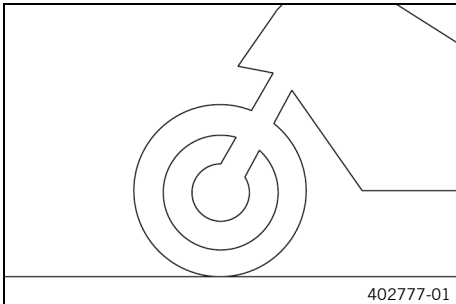

- Secure the motorcycle against falling over.
- Remove the front lifting gear.



13.5 Removing the passenger seat

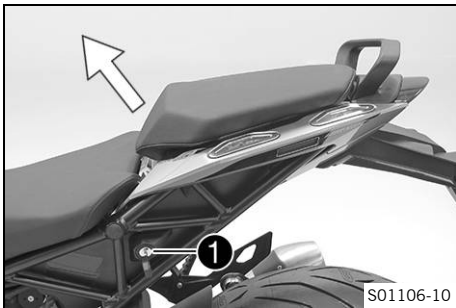

- Insert the RACE-ON key or the black ignition key into seat lock ① and turn clockwise.
- Raise the front of the passenger seat, pull it toward the fuel tank, and take off from above.
- Remove the ignition key.



13.6 Mounting the passenger seat

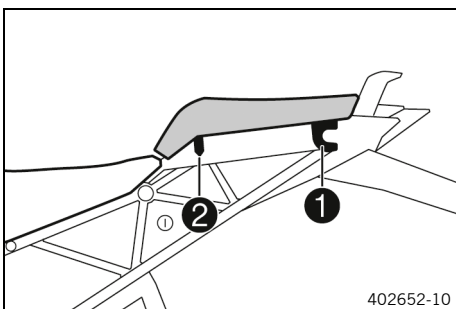

- Attach hooks on the passenger seat to seat mounts ①.
- Lower the front of the passenger seat and push back.
- Position locking pin ② in the lock housing and press passenger seat down at the front.
 - ✓ The locking pin engages with an audible click.
- Check that the passenger seat is mounted correctly.



13.7 Removing the front rider's seat

Preparatory work

- Remove the passenger seat. (📖 p. 91)

Main work

- Press seat release ❶ in the direction of the arrow and lift the front rider's seat at the rear at the same time.
- Detach the front of of the front rider's seat and take it off.

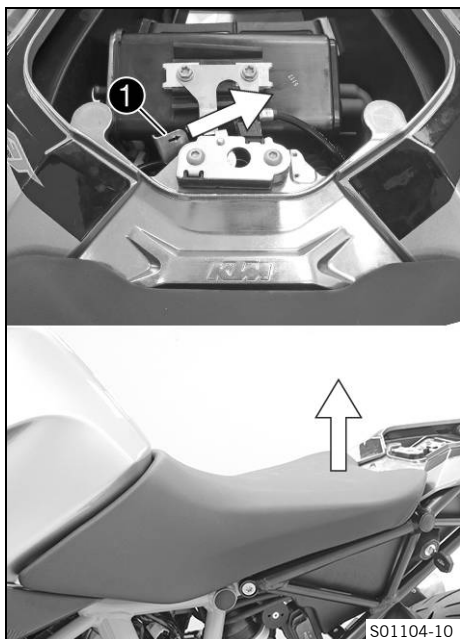

13.8 Mounting the front rider's seat

Main work

- Attach recesses ❶ on the front rider's seat to the fuel tank, push the front rider's seat forward.
- Position locking pin ❷ in the lock housing and push down the front rider's seat at the rear.
 - ✓ The locking pin engages with an audible click.
- Check that the front rider's seat is mounted correctly.

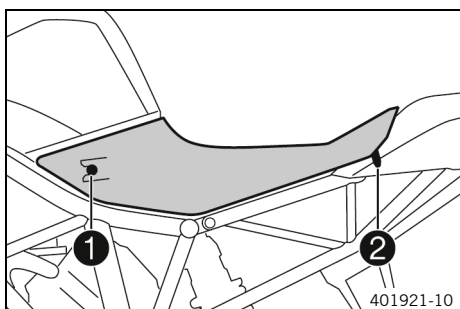

Finishing work

- Mount passenger seat. (📖 p. 91)

13.9 Removing the windshield

- Remove screws ❶ with rubber bushing and windshield ❷.

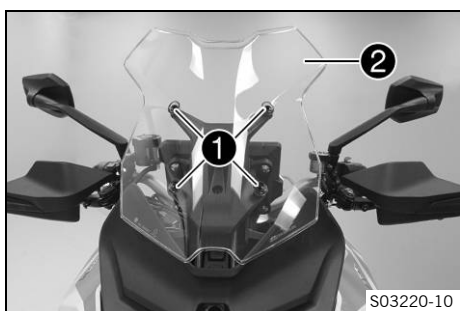

13.10 Installing the windshield

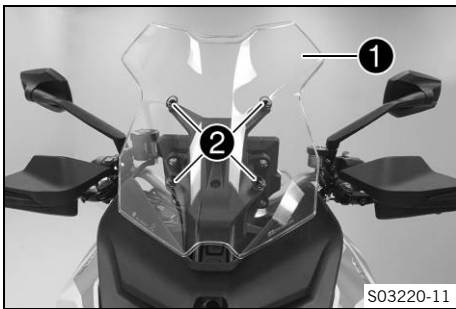

- Position windshield ①.
- Mount and tighten screws ② with rubber bushings.

Guideline

Screw, windshield	M5	3.5 Nm (2.58 lbf ft)
-------------------	----	-------------------------

13.11 Removing the main silencer



Warning

Danger of burns The exhaust system gets very hot when the vehicle is driven.

- Allow the exhaust system to cool down before performing any work on the vehicle.

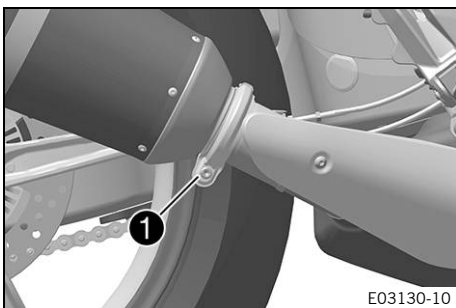

- Remove screw ①.
- Take off exhaust clamp.

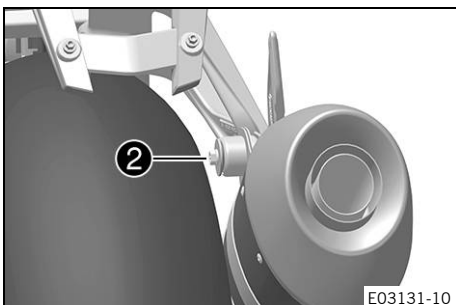

- Remove screw ②.



Warning

Risk of injury Moving parts of the exhaust valve constitute a risk of injury.

- Do not touch the exhaust valve if the main silencer has been removed.
- Make sure that nobody gets caught when the exhaust valve is actuated.

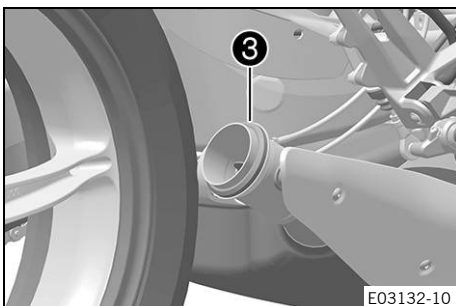

- Take off main silencer.
- Remove seal ring ③.

13.12 Installing the main silencer

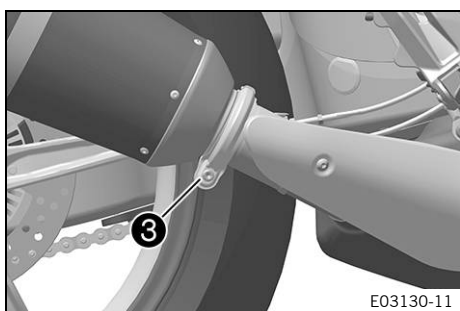
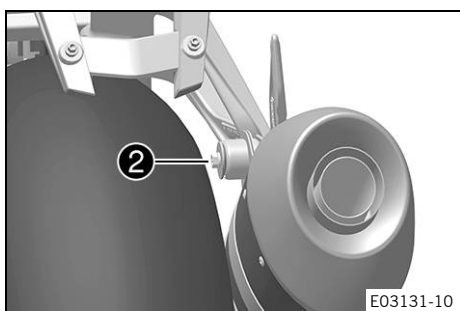
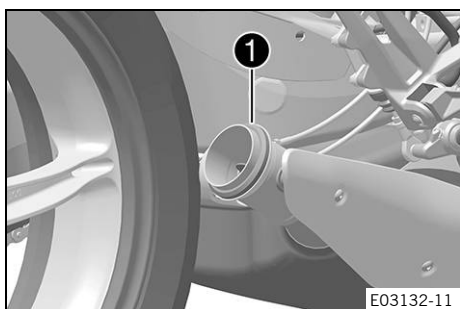

Warning

Risk of injury Moving parts of the exhaust valve constitute a risk of injury.

- Do not touch the exhaust valve if the main silencer has been removed.
- Make sure that nobody gets caught when the exhaust valve is actuated.

- Mount seal ring **1**.
- Position main silencer.
- Mount screw **2**, but do not tighten yet.

Guideline

Remaining screws, chassis	M8	25 Nm (18.4 lbf ft)
---------------------------	----	---------------------

- Position exhaust clamp.
- Mount and tighten screw **3**.

Guideline

Screw, exhaust clamp on main silencer	M6	8 Nm (5.9 lbf ft)
---------------------------------------	----	-------------------

- Tighten screw **2**.

Guideline

Remaining screws, chassis	M8	25 Nm (18.4 lbf ft)
---------------------------	----	---------------------

13.13 Checking the chain for dirt

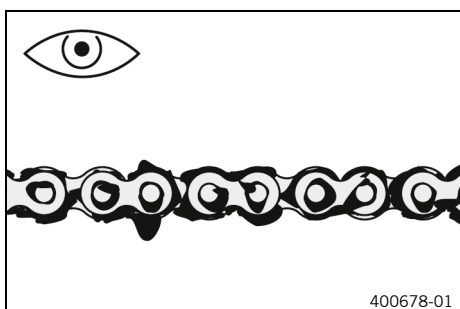

- Check the chain for coarse dirt accumulation.
 - » If the chain is very dirty:
 - Clean the chain. (📖 p. 95)

13.14 Cleaning the chain



Warning

Danger of accidents Lubricants on the tires reduces the road grip.

- Remove lubricants from the tires using a suitable cleaning agent.



Warning

Danger of accidents Oil or grease on the brake discs reduces the braking effect.

- Always keep the brake discs free of oil and grease.
- Clean the brake discs with brake cleaner when necessary.



Note

Environmental hazard Hazardous substances cause environmental damage.

- Dispose of oils, grease, filters, fuel, cleaning agents, brake fluid, etc., correctly and in compliance with the applicable regulations.



Info

The service life of the chain depends largely on its maintenance.
Regular cleaning increases the service life of the chain.

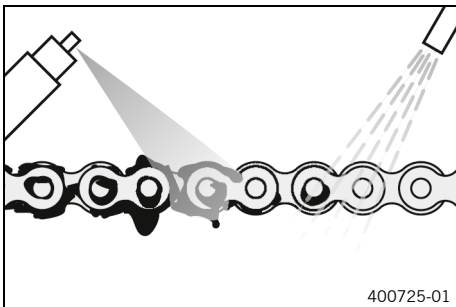

Preparatory work

- Raise the motorcycle with the rear lifting gear. (📖 p. 90)

Main work

- Rinse off loose dirt with a soft jet of water.
- Remove old grease residue with chain cleaner.

Chain cleaner (📖 p. 163)

- After drying, apply chain spray.

Street chain spray (📖 p. 163)

Finishing work

- Remove the rear of the motorcycle from the lifting gear. (📖 p. 90)



13.15 Checking the chain tension



Warning

Danger of accidents Incorrect chain tension damages components and results in accidents.

If the chain is tensioned too much, the chain, engine sprocket, rear sprocket, transmission and rear wheel bearings wear more quickly. Some components may break if overloaded.

If the chain is too loose, the chain may fall off the engine sprocket or the rear sprocket. As a result, the rear wheel locks or the engine will be damaged.

- Check the chain tension regularly.
- Set the chain tension in accordance with the specification.

Preparatory work

- Raise the motorcycle with the rear lifting gear. (📖 p. 90)

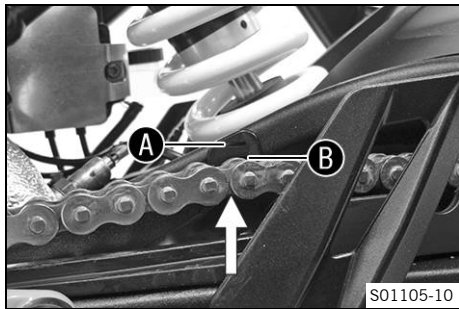

Main work

- Shift the transmission into neutral **N**.
- At the chain sliding guard in the area of markings **A** and **B**, push the chain upward and determine the chain tension.

i Info

The lower chain section must be taut. Chain wear is not always even, so you should repeat this measurement at different chain positions.

The upper edge of the chain is located between markings **A** and **B**.

- » If the chain tension does not meet the specification:
 - Adjust the chain tension. (📖 p. 96)
- Check protection caps **1** for damage and tightness.
 - » If the protection caps are damaged or loose:
 - Replace the protection caps.

Link fork protection cap (61304041100)

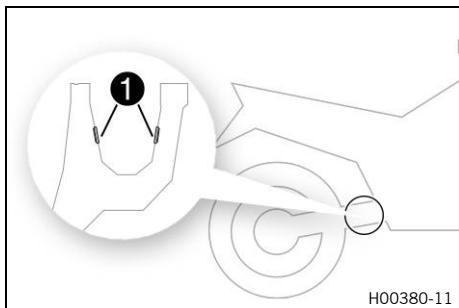

Finishing work

- Remove the rear of the motorcycle from the lifting gear. (📖 p. 90)

13.16 Adjusting the chain tension



Warning

Danger of accidents Incorrect chain tension damages components and results in accidents.

If the chain is tensioned too much, the chain, engine sprocket, rear sprocket, transmission and rear wheel bearings wear more quickly. Some components may break if overloaded.

If the chain is too loose, the chain may fall off the engine sprocket or the rear sprocket. As a result, the rear wheel locks or the engine will be damaged.

- Check the chain tension regularly.
- Set the chain tension in accordance with the specification.

Preparatory work

- Raise the motorcycle with the rear lifting gear. (📖 p. 90)
- Check the chain tension. (📖 p. 95)

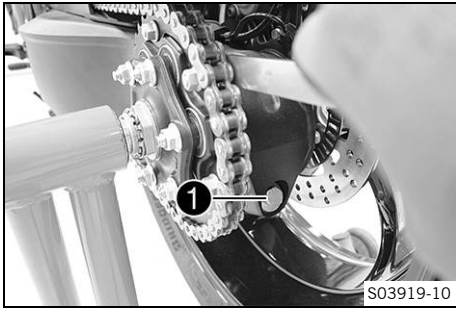

Main work

- Loosen screw ①.
- Set the chain tension by turning the hub housing.

Holding wrench (61329085000)

Handle for holding wrench (60012060000)



Info

Turn clockwise to increase the chain tension; turn counterclockwise to reduce the chain tension.

- Check the chain tension. (📖 p. 95)
- ✓ The chain tension matches the specified value.



Info

Chain wear is not always even, so you should repeat this measurement at different chain positions.

- Tighten screw ①.

Guideline

Screw, eccentric	M16	70 Nm (51.6 lbf ft)
------------------	-----	---------------------

- Remove the rear of the motorcycle from the lifting gear. (📖 p. 90)



13.17 Checking the chain, rear sprocket, engine sprocket, and chain guide

Preparatory work

- Raise the motorcycle with the rear lifting gear. (📖 p. 90)

Main work

- Check rear sprocket and engine sprocket for wear.
 - » If the rear sprocket or engine sprocket is worn:
 - Change the drivetrain kit. 🛠️



Info

The engine sprocket, rear sprocket, and chain should always be replaced together.

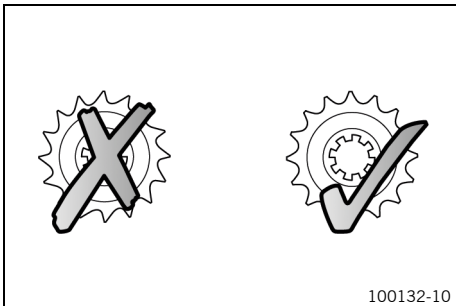

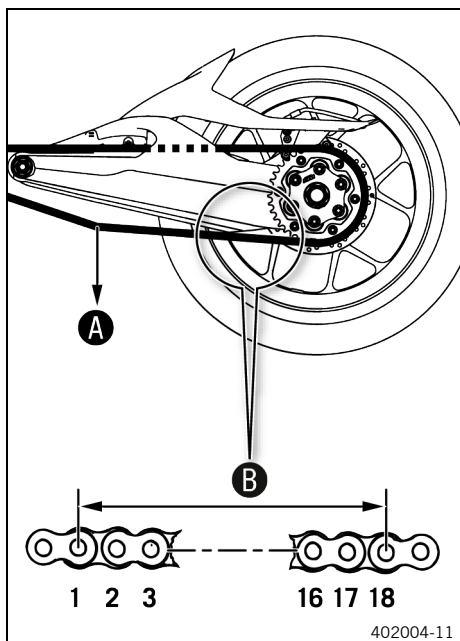

- Shift the transmission into neutral **N**.
 - Pull on the lower chain section with the specified weight **A**.
- Guideline

Weight, chain wear measurement	15 kg (33 lb.)
--------------------------------	----------------

- Measure distance **B** of 18 chain rollers in the lower chain section.

i Info
Chain wear is not always even, so you should repeat this measurement at different chain positions.

Maximum distance B from 18 chain rollers at the longest chain section	272 mm (10.71 in)
--	-------------------

- » If distance **B** is greater than the specified measurement:
 - Change the drivetrain kit. 🛠️

i Info
When a new chain is mounted, the rear sprocket and engine sprocket should also be changed. New chains wear out faster on an old, worn rear sprocket or engine sprocket. For safety reasons, the chain has no chain joint.

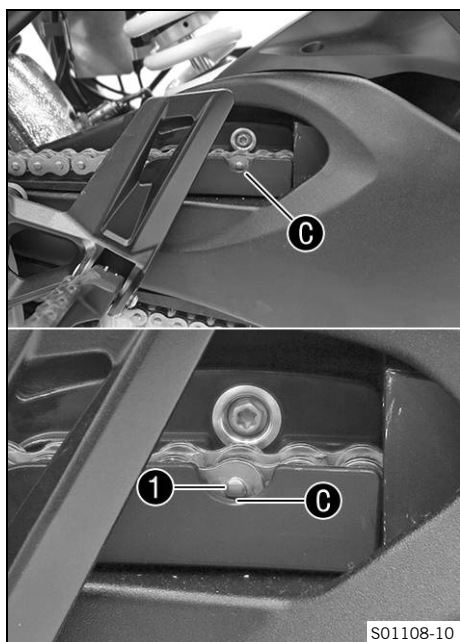

- Check chain sliding guard for wear at the recess.
 - » If chain rivet **1** is no longer visible at bottom edge **C** of the recess of the chain sliding guard:
 - Change the chain sliding guard. 🛠️
- Check that the chain sliding guard is firmly seated.
 - » If the chain sliding guard is loose:
 - Tighten screws on the chain sliding guard.

Guideline

Screw, chain sliding guard	M5	5 Nm (3.7 lbf ft)
----------------------------	----	-------------------

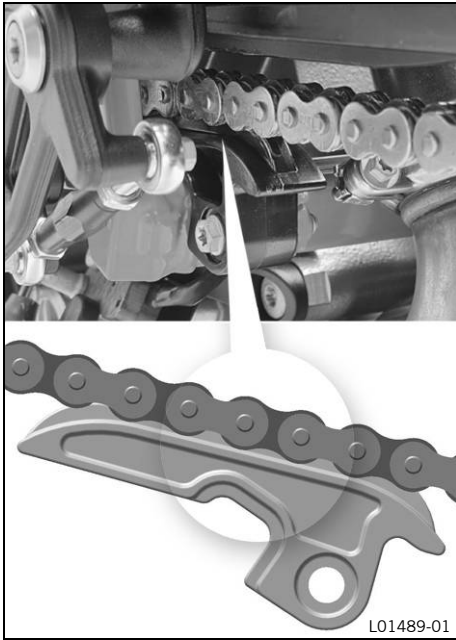

- Check chain sliding piece for wear.
 - » If the lower edge of the chain is in line with or below the chain sliding piece:
 - Change the chain sliding piece. 🛠️
- Check that the chain sliding piece is firmly seated.
 - » If the chain sliding piece is loose:
 - Tighten screw on the chain sliding piece.

Guideline

Remaining screws, chassis	M8	25 Nm (18.4 lbf ft)
---------------------------	----	------------------------

Finishing work

- Remove the rear of the motorcycle from the lifting gear. (📖 p. 90)



13.18 Checking/correcting the fluid level of the hydraulic clutch



Warning

Skin irritation Brake fluid causes skin irritation.

- Keep brake fluid out of the reach of children.
- Wear suitable protective clothing and safety glasses.
- Do not allow brake fluid to come into contact with the skin, the eyes or clothing.
- Consult a doctor immediately if brake fluid has been swallowed.
- Rinse the affected area with plenty of water in the event of contact with the skin.
- Rinse eyes thoroughly with water immediately and consult a doctor if brake fluid comes into contact with the eyes.
- If brake fluid spills on to your clothing, change the clothing.



Note

Environmental hazard Hazardous substances cause environmental damage.

- Dispose of oils, grease, filters, fuel, cleaning agents, brake fluid, etc., correctly and in compliance with the applicable regulations.



Info

The fluid level rises with increasing wear of the clutch facing discs. Never use DOT 5 brake fluid. It is silicone-based and purple in color. Oil seals and clutch lines are not designed for DOT 5 brake fluid. Avoid contact between brake fluid and painted parts. Brake fluid attacks paint. Only use clean brake fluid from a sealed container.

- Move the clutch fluid reservoir mounted on the handlebar to a horizontal position.

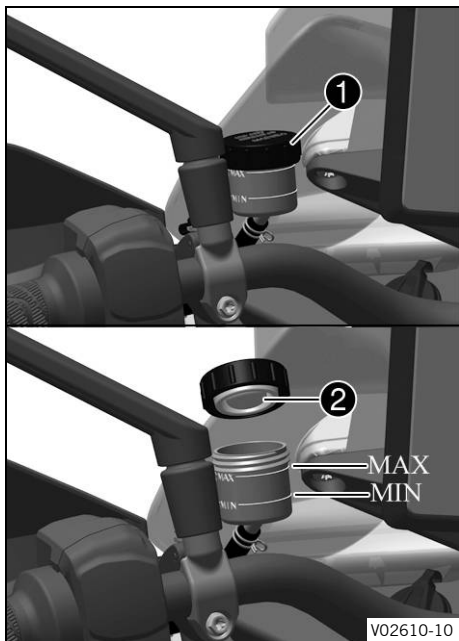

- Check the fluid level.

The fluid level must be between **MIN** and **MAX** markings.

- » If the fluid level does not meet specifications:
 - Remove screw cap **1** with membrane **2**.
 - Correct the fluid level of the hydraulic clutch.

Brake fluid DOT 4 / DOT 5.1 (📖 p. 161)

- Mount and tighten screw cap **1** with membrane **2**.



Info

Clean up overflowed or spilled brake fluid immediately with water.

13.19 Removing the fuel tank spoiler



- Remove screws **1** and **2**.

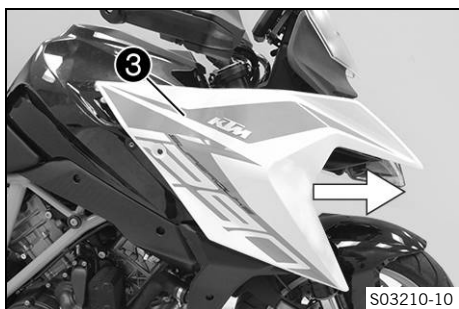

- Carefully pull fuel tank spoiler **3** forward.
- Take off fuel tank spoiler.
- Repeat these steps on the opposite side.

13.20 Installing the fuel tank spoiler

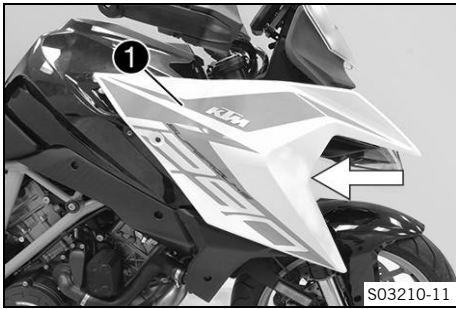

- Position fuel tank spoiler **1**.
- Push fuel tank spoiler **1** to the rear.



Info

Check the fuel tank spoiler is seated properly and attach in the hold points provided.



- Mount and tighten screws **2** and **3**.

Guideline

Screw, trim	M5x12	3.5 Nm (2.58 lbf ft)
-------------	-------	-------------------------

- Repeat these steps on the opposite side.

13.21 Removing front fender

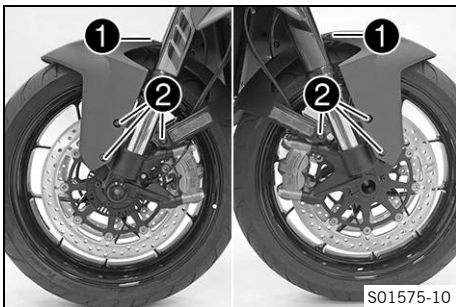

- Remove screws **1**.
- Remove screws **2**.
- Take off the fender.



Info

Pay attention to the brake lines.

13.22 Installing front fender

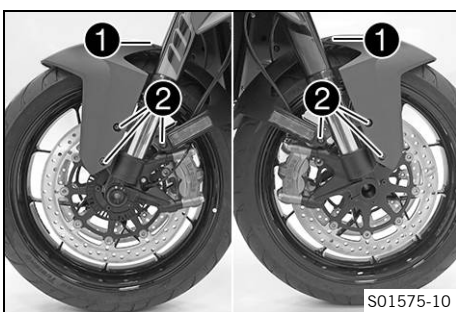

- Position the fender.



Info

Pay attention to where the brake lines are placed.

- Mount and tighten screws **1**.

Guideline

Screw, trim	M5x12	3.5 Nm (2.58 lbf ft)
-------------	-------	-------------------------

- Mount and tighten screws **2**.

Guideline

Remaining screws, chassis	M5	5 Nm (3.7 lbf ft)
---------------------------	----	-------------------

13.23 Cleaning the dust boots of the fork legs

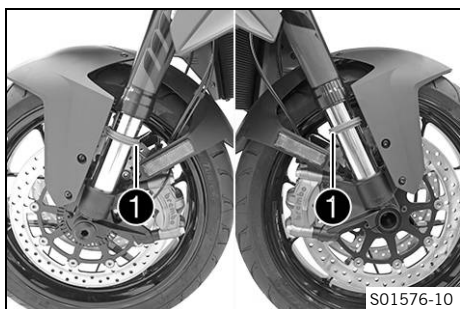

Preparatory work

- Raise the motorcycle with the rear lifting gear. (📖 p. 90)
- Lift the motorcycle with the front lifting gear. (📖 p. 90)

Main work

- Push dust boots ❶ of both fork legs downward.

Info

The dust boots remove dust and coarse dirt particles from the inside fork tubes. Over time, dirt can accumulate behind the dust boots. If this dirt is not removed, the oil seals behind can start to leak.



Warning

Danger of accidents Oil or grease on the brake discs reduces the braking effect.

- Always keep the brake discs free of oil and grease.
- Clean the brake discs with brake cleaner when necessary.

- Clean and oil the dust boots and inner fork tubes of both fork legs.

Universal oil spray (📖 p. 163)

- Press dust boots back into the installation position.
- Remove excess oil.

Finishing work

- Take the motorcycle off the front lifting gear. (📖 p. 91)
- Remove the rear of the motorcycle from the lifting gear. (📖 p. 90)

14.1 Anti-lock braking system (ABS)

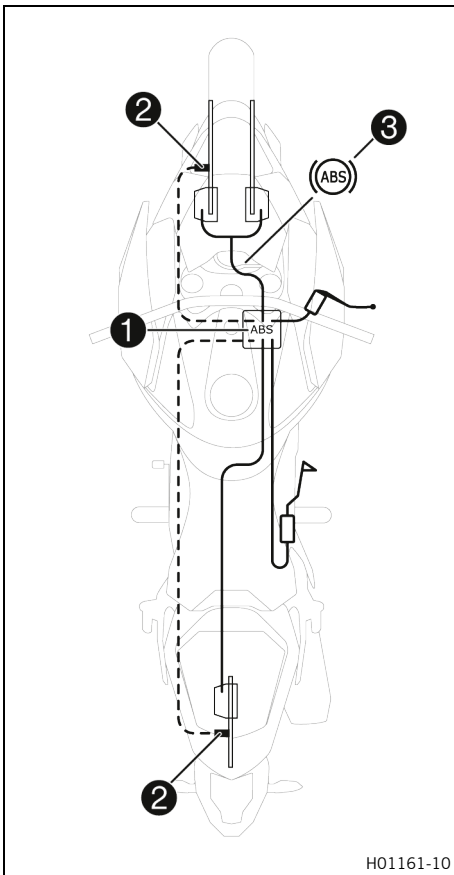

The ABS module ①, which consists of a hydraulic unit, ABS control unit, and return pump, is installed on the right side of the vehicle below the fuel tank. One wheel speed sensor ② is located in each case on the front and the rear wheel.



Warning

Danger of accidents Changes to the vehicle impair the function of the ABS.

- Do not make any changes to the suspension travel.
- Only use spare parts on the brake system which have been approved and recommended by KTM.
- Only use tires/wheels approved by KTM with the corresponding speed index.
- Maintain the specified tire pressure.
- Ensure that service work and repairs are performed professionally. (Your authorized KTM workshop will be glad to help.)

ABS is a safety system that prevents locking of the wheels when driving straight ahead without the influence of lateral forces.



Warning

Danger of accidents Driving aids can reduce the probability of a fall only within physical limits.

It is not always possible to compensate for extreme riding situations, for example with luggage loaded with a high center of gravity, varying road surfaces, steep descents or full braking without disengaging the gear.

- Adapt your riding style to the road conditions and your driving ability.

ABS has two operating modes: the "**Road**" and "**Supermoto**" ABS modes.

In the "**Road**" ABS mode, the ABS controls both wheels.

In the "**Supermoto**" ABS mode, the ABS only controls the front wheel. There is no ABS control on the rear wheel. ABS warning lamp ③ flashes slowly to remind you that the "**Supermoto**" ABS mode is active.



Info

In the "**Supermoto**" ABS mode, the rear wheel may lock, and there is a risk of falling.

The ABS operates with two independent brake circuits (front and rear brakes). When the ABS control unit detects a locking tendency in a wheel, ABS begins regulating the brake pressure. The control function causes a slight pulsing of the hand and foot brake levers.

The ABS warning lamp ③ must light up after the ignition is switched on and go out after starting off. If it does not go out after starting off or if it is lit while riding, this indicates a fault in the

ABS. In this case, the ABS is no longer enabled and the wheels may lock during braking. The brake system itself stays functional; only ABS control is not available.

The ABS warning lamp may also light up if the rotating speeds of the front and rear wheels differ greatly under extreme riding conditions, for example when making "wheelies" or if the rear wheel spins. This causes the ABS to switch off.

To reactivate the ABS, the vehicle must be stopped and the ignition switched off. The ABS is reactivated when the vehicle is switched on again. The ABS warning lamp goes out after starting off.

MSC

The **MSC** is a supplementary function for the ABS that can prevent blocking and slipping of the wheels during braking when the vehicle is inclined (riding in curves) within the physical limitations. The 6-D sensor makes the ABS control dependent on the angle of inclination and pitch.

ABS control that is dependent on the inclination and pitch angle improves the riding stability and braking effect in all riding situations. The **MSC** also reduces the righting moment during hard braking in curves. This prevents the motorcycle from righting itself from an inclined angle and moving along a larger curve radius.

Due to the additional electronic control of the brake force distribution between the two wheels, the braking force is optimally distributed and the motorcycle is additionally stabilized.



Info

The **MSC** is only active in ABS mode "**Road**".
There is no cornering ABS in "**Supermoto**" ABS mode.

14.2 Rear brake temperature monitoring (BTM)

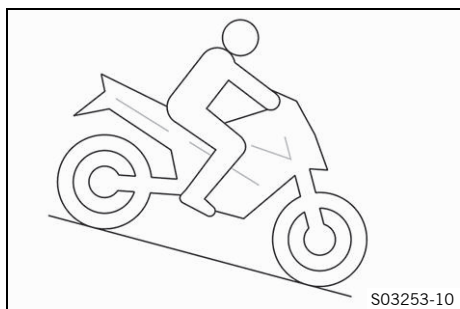

Warning

Danger of accidents The brake temperature monitoring does not protect from overheating.

The brake temperature is calculated, not measured.

- See instructions in the "Braking" chapter.
- Stop immediately, even if no temperature warning is displayed, if the brake lever pressure point becomes spongy.

When the rear brake is used frequently and for excessively long periods, for example on long downhill stretches, the temperature of the brake system may increase.

An overheating brake system results in reduced brake power through to failure of the brake system.

A brake temperature monitoring warning (📖 p. 31) is displayed in the combination instrument.

In order to avoid overloading the rear brake system, use the front and rear brakes, as well as the engine braking effect in combination.

14.3 Checking the brake discs



Warning

Danger of accidents Worn-out brake discs reduce the braking effect.

- Make sure that worn-out brake discs are replaced immediately. (Your authorized KTM workshop will be glad to help.)

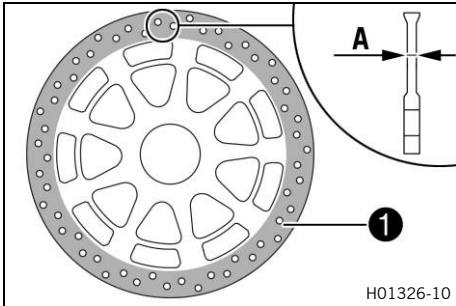

- Check the front and rear brake disc thickness at multiple points for the dimension **A**.



Info

Wear will reduce the thickness of the brake disc at contact surface **1** of the brake linings.

Brake discs - wear limit	
front	4.5 mm (0.177 in)
rear	4.5 mm (0.177 in)

- » If the brake disc thickness is less than the specified value.
 - Change the front brake discs. 🛠️
 - Change the rear brake disc. 🛠️
- Check the front and rear brake discs for damage, cracking, and deformation.
 - » If the brake disc exhibits damage, cracking, or deformation:
 - Change the front brake discs. 🛠️
 - Change the rear brake disc. 🛠️



14.4 Checking the front brake fluid level



Warning

Danger of accidents An insufficient brake fluid level will cause the brake system to fail.

If the brake fluid level drops below the **MIN** marking, the brake system is leaking or the brake linings are worn down.

- Check the brake system and do not continue riding until the problem is eliminated. (Your authorized KTM workshop will be glad to help.)



Warning

Danger of accidents Old brake fluid reduces the braking effect.

- Make sure that brake fluid for the front and rear brake is changed in accordance with the service schedule. (Your authorized KTM workshop will be glad to help.)

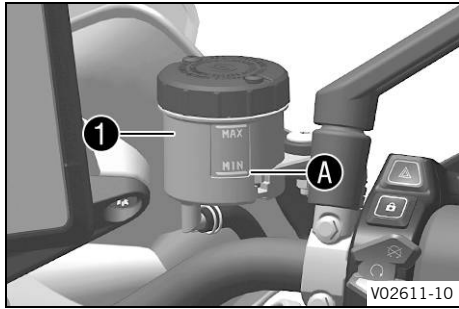

- Move brake reservoir mounted on the handlebar to a horizontal position.
- Check brake fluid level in brake fluid reservoir ①.
 - » If the brake fluid level has dropped below **MIN** marking A:
 - Add front brake fluid. 📖 (p. 106)

14.5 Adding front brake fluid 📖



Warning

Danger of accidents An insufficient brake fluid level will cause the brake system to fail.

If the brake fluid level drops below the **MIN** marking, the brake system is leaking or the brake linings are worn down.

- Check the brake system and do not continue riding until the problem is eliminated. (Your authorized KTM workshop will be glad to help.)



Warning

Skin irritation Brake fluid causes skin irritation.

- Keep brake fluid out of the reach of children.
- Wear suitable protective clothing and safety glasses.
- Do not allow brake fluid to come into contact with the skin, the eyes or clothing.
- Consult a doctor immediately if brake fluid has been swallowed.
- Rinse the affected area with plenty of water in the event of contact with the skin.
- Rinse eyes thoroughly with water immediately and consult a doctor if brake fluid comes into contact with the eyes.
- If brake fluid spills on to your clothing, change the clothing.



Warning

Danger of accidents Old brake fluid reduces the braking effect.

- Make sure that brake fluid for the front and rear brake is changed in accordance with the service schedule. (Your authorized KTM workshop will be glad to help.)



Note

Environmental hazard Hazardous substances cause environmental damage.

- Dispose of oils, grease, filters, fuel, cleaning agents, brake fluid, etc., correctly and in compliance with the applicable regulations.



Info

Never use DOT 5 brake fluid. It is silicone-based and purple in color. Oil seals and brake lines are not designed for DOT 5 brake fluid.

Avoid contact between brake fluid and painted parts. Brake fluid attacks paint.

Only use clean brake fluid from a sealed container.

Preparatory work

- Check the front brake linings. 📖 (p. 107)

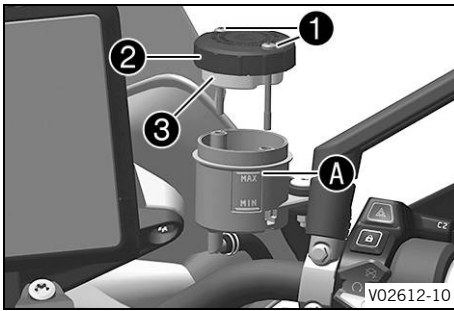

Main work

- Move brake reservoir mounted on the handlebar to a horizontal position.
- Remove screws ①.
- Take off cover ② with membrane ③.
- Add brake fluid up to **MAX** marking ④.

Brake fluid DOT 4 / DOT 5.1 (📖 p. 161)
--

- Position cover ② with membrane ③.
- Mount and tighten screws ①.



Info

Clean up overflowed or spilled brake fluid immediately with water.

14.6 Checking the front brake linings



Warning

Danger of accidents Worn-out brake linings reduce the braking effect.

- Ensure that worn-out brake linings are replaced immediately. (Your authorized KTM workshop will be glad to help.)



Warning

Danger of accidents Damaged brake discs reduce the braking effect.

If the brake linings are not changed in time, the brake lining carriers grind against the brake disc. As a consequence, the braking effect is greatly reduced and the brake discs are destroyed.

- Check the brake linings regularly.

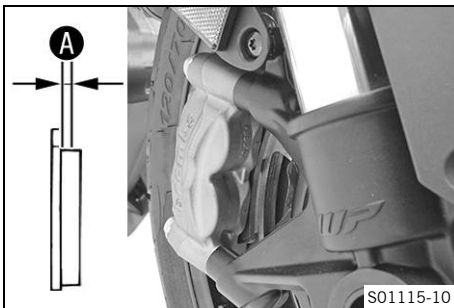

- Check all brake linings on both brake calipers to ensure they have the minimum thickness ④.

Minimum thickness ④	≥ 1 mm (≥ 0.04 in)
---------------------	--------------------

- » If the minimum thickness is less than specified:
 - Change the front brake linings. 🛠️
- Check all brake linings on both brake calipers for damage and cracking.
 - » If there is damage or cracking:
 - Change the front brake linings. 🛠️

14.7 Checking the rear brake fluid level



Warning

Danger of accidents An insufficient brake fluid level will cause the brake system to fail.

If the brake fluid level drops below the **MIN** marking, the brake system is leaking or the brake linings are worn down.

- Check the brake system and do not continue riding until the problem is eliminated. (Your authorized KTM workshop will be glad to help.)



Warning

Danger of accidents Old brake fluid reduces the braking effect.

- Make sure that brake fluid for the front and rear brake is changed in accordance with the service schedule. (Your authorized KTM workshop will be glad to help.)

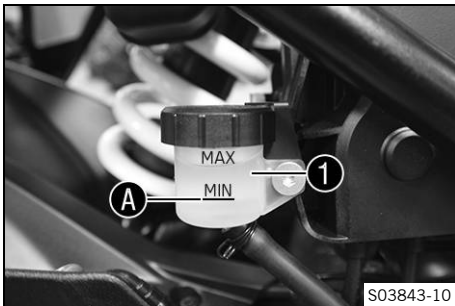

- Stand vehicle upright.
- Check brake fluid level in brake fluid reservoir ①.
 - » If the fluid level reaches the **MIN** marking A:
 - Add rear brake fluid. 🛠️ (p. 108)

14.8 Adding rear brake fluid 🛠️



Warning

Danger of accidents An insufficient brake fluid level will cause the brake system to fail.

If the brake fluid level drops below the **MIN** marking, the brake system is leaking or the brake linings are worn down.

- Check the brake system and do not continue riding until the problem is eliminated. (Your authorized KTM workshop will be glad to help.)



Warning

Skin irritation Brake fluid causes skin irritation.

- Keep brake fluid out of the reach of children.
- Wear suitable protective clothing and safety glasses.
- Do not allow brake fluid to come into contact with the skin, the eyes or clothing.
- Consult a doctor immediately if brake fluid has been swallowed.
- Rinse the affected area with plenty of water in the event of contact with the skin.
- Rinse eyes thoroughly with water immediately and consult a doctor if brake fluid comes into contact with the eyes.
- If brake fluid spills on to your clothing, change the clothing.



Warning

Danger of accidents Old brake fluid reduces the braking effect.

- Make sure that brake fluid for the front and rear brake is changed in accordance with the service schedule. (Your authorized KTM workshop will be glad to help.)



Note

Environmental hazard Hazardous substances cause environmental damage.

- Dispose of oils, grease, filters, fuel, cleaning agents, brake fluid, etc., correctly and in compliance with the applicable regulations.



Info

Never use DOT 5 brake fluid. It is silicone-based and purple in color. Oil seals and brake lines are not designed for DOT 5 brake fluid. Avoid contact between brake fluid and painted parts. Brake fluid attacks paint. Only use clean brake fluid from a sealed container.

Preparatory work

- Check the brake linings of the rear brake. (📖 p. 109)

Main work

- Position the vehicle vertically.
- Remove screw ① with the screw cap lock.

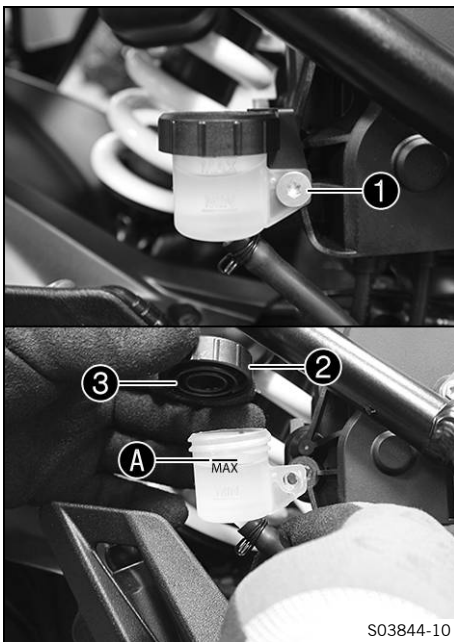

Info

Make sure that the reservoir stays vertical and no brake fluid runs out.

- Remove screw cap ② with the washer and membrane ③.
- Add brake fluid up to the **MAX** marking **A**.

Brake fluid DOT 4 / DOT 5.1 (📖 p. 161)

- Mount and tighten screw cap ② with the shim and membrane ③.
- Position the screw cap lock and mount and tighten screw ①.

Guideline

Screw, brake fluid reservoir, rear brake		3.5 Nm (2.58 lbf ft)
--	--	-------------------------



Info

Immediately clean up any brake fluid that has overflowed or spilled with water.



14.9 Checking the brake linings of the rear brake



Warning

Danger of accidents Worn-out brake linings reduce the braking effect.

- Ensure that worn-out brake linings are replaced immediately. (Your authorized KTM workshop will be glad to help.)



Warning

Danger of accidents Damaged brake discs reduce the braking effect.

If the brake linings are not changed in time, the brake lining carriers grind against the brake disc. As a consequence, the braking effect is greatly reduced and the brake discs are destroyed.

- Check the brake linings regularly.

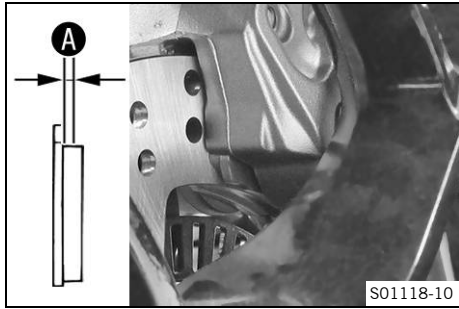

- Check the brake linings for minimum thickness **A**.

Minimum thickness A	$\geq 1 \text{ mm } (\geq 0.04 \text{ in})$
----------------------------	---

- » If the minimum thickness is less than specified:
 - Change the rear brake linings. ↩
- Check the brake linings for damage and cracking.
 - » If there is damage or cracking:
 - Change the rear brake linings. ↩

15.1 Removing the front wheel

Preparatory work

- Raise the motorcycle with the rear lifting gear. (📖 p. 90)
- Lift the motorcycle with the front lifting gear. (📖 p. 90)

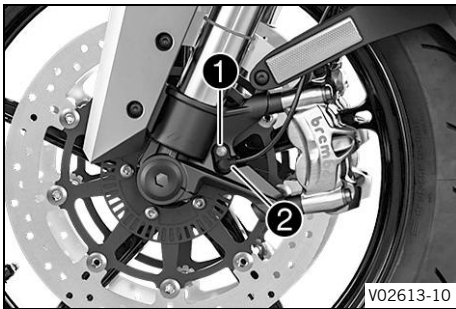

Main work

- Remove screw 1 and pull wheel speed sensor 2 out of the hole.

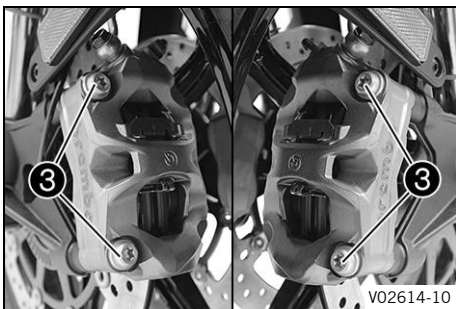

- Remove screws 3 from both brake calipers.
- Press back brake linings by slightly tilting the brake calipers laterally on the brake disc. Pull brake calipers carefully back from the brake discs and hang to the side.



Info

Do not operate the hand brake lever if the brake calipers have been removed.

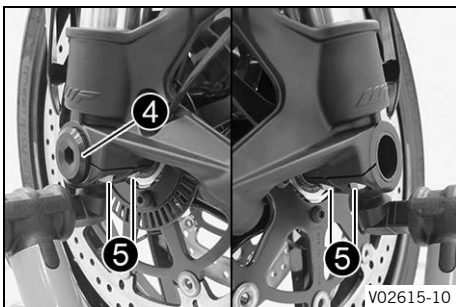

- Loosen screw 4 by several rotations.
- Loosen screws 5.
- Using your hand, press on screw 4 to push the wheel spindle out of the axle clamp.
- Remove screw 4.



Warning

Danger of accidents Damaged brake discs reduce the braking effect.

- Always lay the wheel down in such a way that the brake discs are not damaged.

- Hold front wheel and remove wheel spindle. Take the front wheel out of the fork.
- Remove spacers 6.

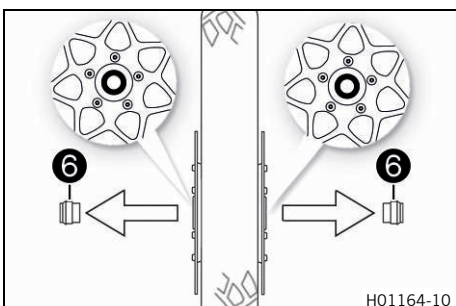

15.2 Installing the front wheel ↩

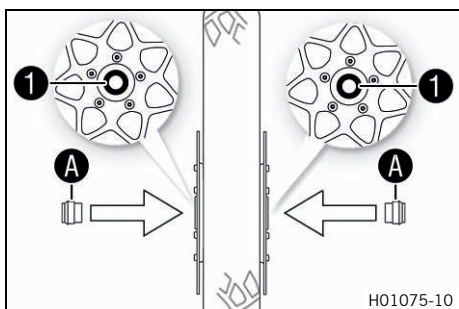

- Check the wheel bearing for damage and wear.
 - » If the wheel bearing is damaged or worn:
 - Change front wheel bearing. ↩
- Clean and grease shaft seal rings 1 and contact surfaces A of the spacers.

Long-life grease (📖 p. 163)

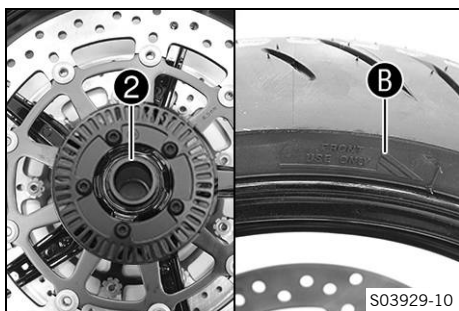

- Insert wide spacer 2 on the left in the direction of travel.

i Info
 Arrow B indicates the direction of travel of the front wheel.
 The wheel speed sensor wheel is on the left viewed in the direction of travel.

- Insert the narrow spacer on the right in the direction of travel.

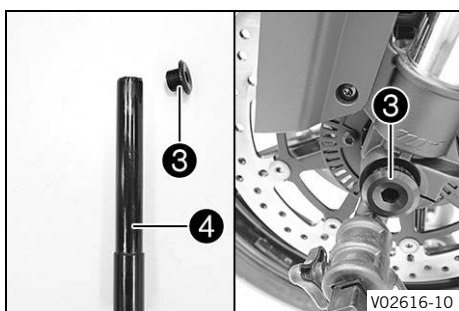

- Clean screw 3 and wheel spindle 4.
- Grease wheel spindle lightly.

Long-life grease (📖 p. 163)

- Jack up the front wheel into the fork, position it, and insert the wheel spindle.
- Mount and tighten screw 3.

Guideline

Screw, front wheel spindle	M25x1.5	45 Nm (33.2 lbf ft) Thread greased
----------------------------	---------	---------------------------------------

- Position brake calipers and check that the brake linings are seated correctly.
- Mount screws 5 on both brake calipers, but do not tighten yet.

Guideline

Screw, front brake caliper	M10	45 Nm (33.2 lbf ft) Loctite®243™
----------------------------	-----	--

- Operate the hand brake lever repeatedly until the brake linings are in contact with the brake disc and there is a pressure point. Secure the hand brake lever in the activated position.
 - ✓ The brake calipers straighten.

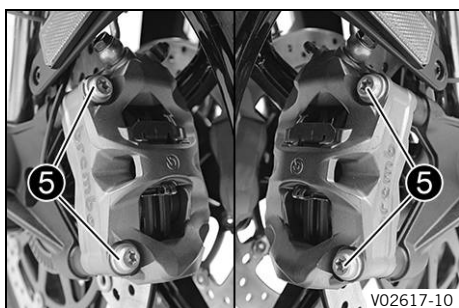

- Tighten screws **5** on both brake calipers.

Guideline

Screw, front brake caliper	M10	45 Nm (33.2 lbf ft) Loctite®243™
----------------------------	-----	--

- Remove the locking piece of the hand brake lever.

- Position wheel speed sensor **6** in the hole.

- Mount and tighten screw **7**.

Guideline

Screw, front wheel speed sensor	M6	4 Nm (3 lbf ft)
---------------------------------	----	-----------------

- Take the motorcycle off the front lifting gear. (📖 p. 91)

- Remove the rear of the motorcycle from the lifting gear. (📖 p. 90)

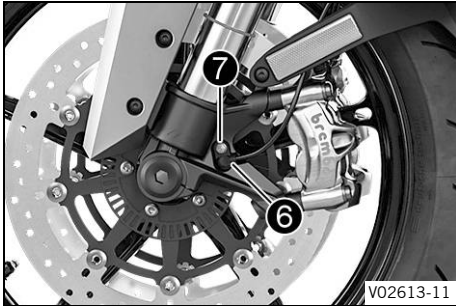

V02613-11

- Operate the front brake and compress the fork a few times firmly.

✓ The fork legs straighten.

- Tighten screws **8**.

Guideline

Screw, axle clamp	M8	15 Nm (11.1 lbf ft)
-------------------	----	---------------------

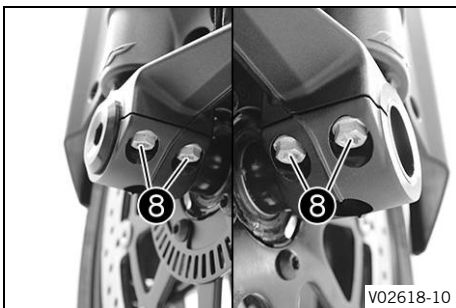

V02618-10

15.3 Removing the rear wheel 🛠️

Preparatory work

- Raise the motorcycle with the rear lifting gear. (📖 p. 90)
- Remove main silencer. 🛠️ (📖 p. 93)

Main work

- Remove the inside locking wire **1**.
- Remove the outside locking wire **2**.

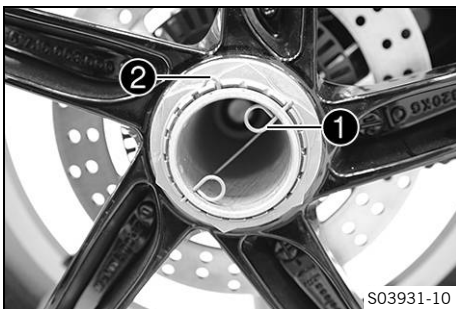

S03931-10

- Have an assistant operate the rear brake.

- Loosen nut **3** and remove it with washer **4**.

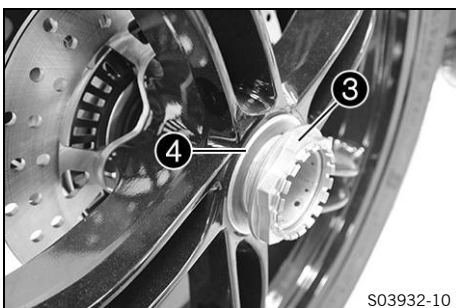

S03932-10

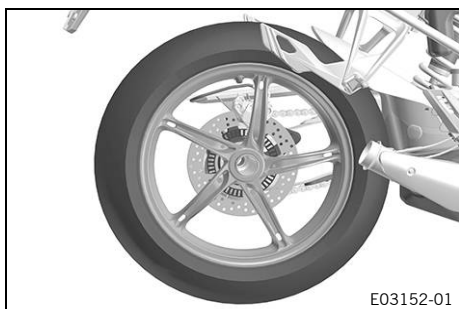

- Take off the rear wheel.

15.4 Installing the rear wheel



Warning

Danger of accidents Oil or grease on the brake discs reduces the braking effect.

- Always keep the brake discs free of oil and grease.
- Clean the brake discs with brake cleaner when necessary.

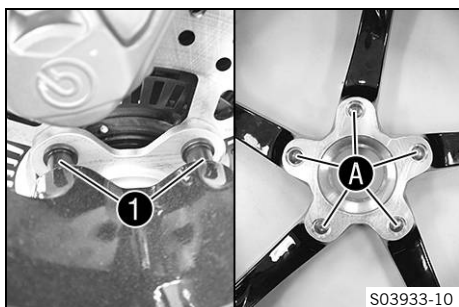

Main work

- Check the rear wheel bearing for damage and wear.
 - » If the rear wheel bearing is damaged or worn:
 - Change the rear wheel bearing.
- Clean and grease the threads of the wheel axle and axle nut.

Long-life grease (p. 163)

- Slide the rear wheel onto the axle.
 - ✓ Driving pins ① engage in drilled holes A of the rim.

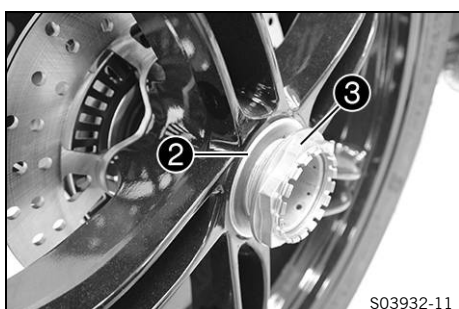

- Mount washer ② and nut ③.
- Have an assistant operate the rear brake.
- Tighten nut ③.

Guideline

Nut, rear axle	M50x1.5	250 Nm (184.4 lbf ft) Thread greased/lock locking wire with locking varnish
----------------	---------	--

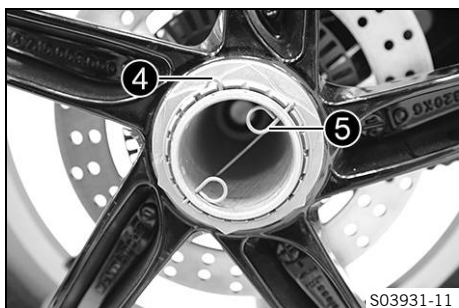

- Mount outside locking wire ④.
- Mount inside locking wire ⑤.
 - ✓ The pins of the locking wires engage in the drilled holes of the wheel axle.

Finishing work

- Remove the rear of the motorcycle from the lifting gear. (p. 90)
- Install main silencer. (p. 94)

15.5 Checking the tire condition



Warning

Danger of accidents If a tire bursts while riding, the vehicle becomes uncontrollable.

- Ensure that damaged or worn tires are replaced immediately. (Your authorized KTM workshop will be glad to help.)



Warning

Danger of crashing Different tire tread patterns on the front and rear wheel impair the handling characteristic.

Different tire tread patterns can make the vehicle significantly more difficult to control.

- Make sure that only tires with a similar tire tread pattern are fitted to the front and rear wheel.



Warning

Danger of accidents Non-approved or non-recommended tires and wheels impact the handling characteristic.

- Only use tires/wheels approved by KTM with the corresponding speed index.



Warning

Danger of accidents New tires have reduced road grip.

The contact surface on new tires is not yet roughened.

- Run in new tires with moderate riding at alternating angles.
Running-in phase 200 km (124 mi)



Info

Tire type, tire condition, and tire pressure influence the braking and handling characteristics of the vehicle.

Worn tires are particularly unfavorable on wet surfaces.

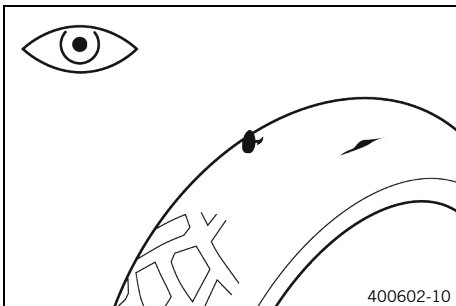

- Check front and rear tires for cuts, run-in objects, and other damage.
 - » If the tires have cuts, run-in objects, or other damage:
 - Change the tires. 🛠️
- Check tread depth.



Info

Observe the minimum profile depth required by national law.

Minimum tread depth	≥ 2 mm (≥ 0.08 in)
---------------------	--------------------

- » If the tread depth is less than the minimum tread depth:
 - Change the tires. 🛠️

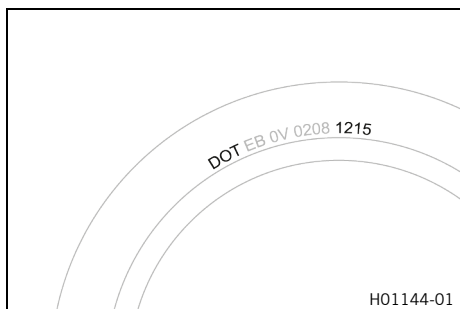

- Check tire age.



Info

The tire date of manufacture is usually contained in the tire label and is indicated by the last four digits of the **DOT** number. The first two digits indicate the week of manufacture and the last two digits the year of manufacture.

KTM recommends that the tires be changed after 5 years at the latest, regardless of the actual state of wear.

- » If the tires are more than 5 years old:
 - Change the tires. 🛠️

15.6 Checking tire pressure



Info

Low tire pressure leads to abnormal wear and overheating of the tire.

Correct tire pressure ensures optimal riding comfort and maximum tire service life.

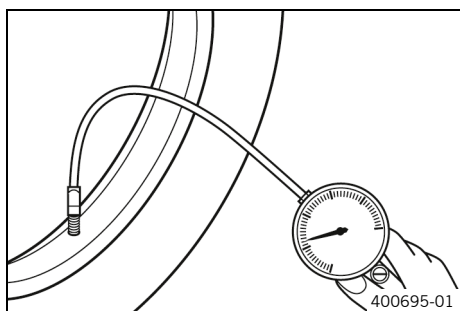

- Remove protection cap.
- Check tire pressure when the tires are cold.

Tire pressure, solo / with passenger / full payload	
front: with cold tires	2.7 bar (39 psi)
rear: with cold tires	2.9 bar (42 psi)

- » If the tire pressure does not meet specifications:
 - Correct tire pressure.
- Mount protection cap.

15.7 Using tire repair spray

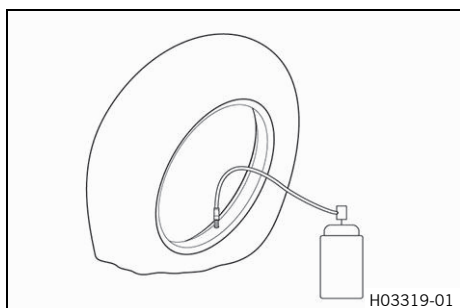

Warning

Danger of accidents Incorrect use of tire repair spray will result in the repaired tire losing pressure.

Tire repair spray cannot be used for all types of damage.

- Observe the instructions and specifications of the manufacturer of the tire repair spray.
- After repairing a tire with tire repair spray, ride slowly and carefully.
- Ride no further than to the nearest workshop and have the tire changed.

Tire repair spray should only be used in an emergency. We recommend transporting the broken down vehicle to the nearest workshop instead of using tire repair spray.

(SUPER DUKE GT EU/CN)

Note

Material damage Tire repair spray damages the tire pressure sensor.

- Note that after using tire repair spray, the tire pressure sensor may need to be replaced.
-

16.1 Low beam

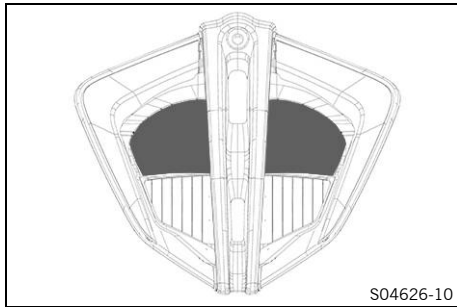

The low beam is integrated in the main headlight. The low beam is activated when the ignition is switched on. To save power in the 12-V battery, the low beam is deactivated again after 5 seconds if the engine is not started. If the ignition is accidentally switched off during the journey, the low beam remains on.

16.2 High beam

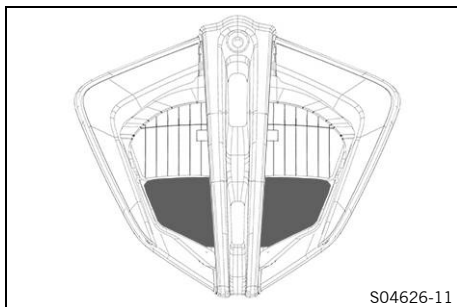

The high beam is integrated in the main headlight.

16.3 Daytime running light (DRL) (SUPER DUKE GT EU/JP)

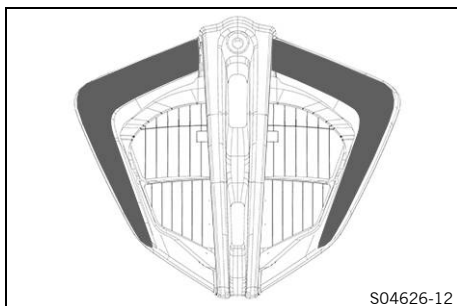

Warning

Danger of accidents When visibility is poor, the daytime running light is not a substitute for the low beam.

Automatic switching between the daytime running light and low beam may only be partially available when visibility is significantly impaired due to fog, snow or rain.

- Ensure that the appropriate type of lighting is always selected.
- If necessary switch off the daytime running lights using the menu before going on a ride or when stopped so that the low beam is switched on permanently.
- Make sure that the daytime running light is deactivated with the diagnostics tool when the menu item is not available, but the low beam is required. (Your authorized KTM workshop will be glad to help.)
- Note the legal regulations regarding the daytime running light.

The daytime running light/parking light is integrated in the main headlight.

The daytime running light can be switched on when visibility conditions are good. Activate the daytime running light in the combination instrument. This is controlled by the ambient light sensor in the combination instrument. When visibility conditions are good, the low beam is switched off and the daytime running light is switched on. It is four times brighter than the position light.

When the daytime running light is switched off, it serves as a position light.

16.4 Cornering light



The cornering light is located on the left and the right in the fuel tank spoiler.

i Info

To activate the cornering light, the low beam must be switched on and the daytime running light switched off.

The cornering lights are activated:

Lean angle for the lower LED	$\geq 12^\circ$
Lean angle for the middle LED	$\geq 20^\circ$
Lean angle for the upper LED	$\geq 28^\circ$
Speed	$\geq 6 \text{ km/h}$ ($\geq 3.7 \text{ mph}$)

16.5 Socket for electrical accessories

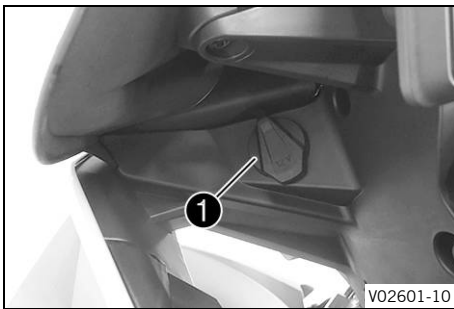

Socket **1** for electrical accessories is mounted on the left side of the instrument support.

It is connected to the permanent positive and is fuse-protected.

Socket for electrical accessories	
Voltage	12 V
Maximum current consumption	10 A

16.6 Removing the 12-V battery



Warning

Risk of injury Battery acid and battery gases cause serious chemical burns.

- Keep 12 V batteries out of the reach of children.
- Wear suitable protective clothing and safety glasses.
- Avoid contact with battery acid and battery gases.
- Keep sparks or open flames away from the 12 V battery.
- Only charge 12 V batteries in well-ventilated rooms.
- Rinse the affected area immediately with plenty of water in the event of contact with the skin.
- Rinse eyes with water for at least 15 minutes and consult a doctor immediately if battery acid and battery gases get into the eyes.



Caution

Danger of accidents Electronic components and safety devices will be damaged if the 12-V battery is discharged or missing.

If the 12-V battery is discharged or defective, malfunctions in the vehicle electronics can occur, especially when starting.

- Never operate the vehicle with a discharged 12-V battery or without a 12-V battery.

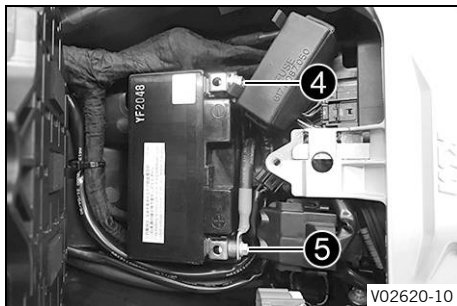
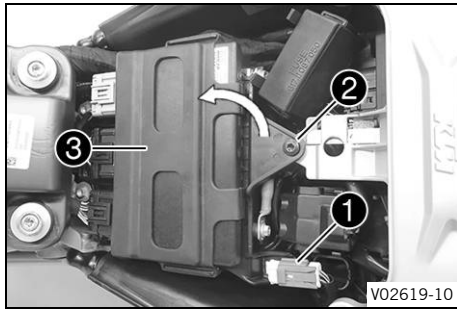

Preparatory work

- Remove the passenger seat. (📖 p. 91)
- Remove the front rider's seat. (📖 p. 92)

Main work

- Pull diagnostics connector **1** off the holder.
- Remove screw **2**.
- Lift cover **3** at the rear and pull toward the rear.
- Fold up cover.

- Disconnect negative cable **4** from the 12-V battery.



Info

To prevent damage to the onboard electronics, first disconnect the negative cable from the 12-V battery.

- Disconnect positive cable **5** from the 12-V battery.
- Take the 12-V battery out of the battery compartment.

16.7 Installing the 12-V battery ↗



Warning

Risk of injury Battery acid and battery gases cause serious chemical burns.

- Keep 12 V batteries out of the reach of children.
- Wear suitable protective clothing and safety glasses.
- Avoid contact with battery acid and battery gases.
- Keep sparks or open flames away from the 12 V battery.
- Only charge 12 V batteries in well-ventilated rooms.
- Rinse the affected area immediately with plenty of water in the event of contact with the skin.
- Rinse eyes with water for at least 15 minutes and consult a doctor immediately if battery acid and battery gases get into the eyes.



Caution

Danger of accidents Electronic components and safety devices will be damaged if the 12-V battery is discharged or missing.

If the 12-V battery is discharged or defective, malfunctions in the vehicle electronics can occur, especially when starting.

- Never operate the vehicle with a discharged 12-V battery or without a 12-V battery.

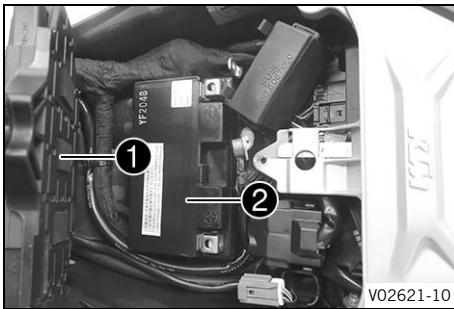

Main work

- Fold up cover ①.
- Insert 12-V battery ② into the battery compartment.

12-V battery (YTZ14S) (📖 p. 153)

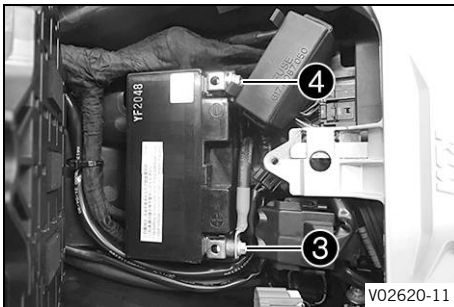

- Position positive cable ③, mount and tighten the screw.

Guideline

Screw, battery terminal	M6	4.5 Nm (3.32 lbf ft)
-------------------------	----	-------------------------

i Info

To prevent damage to the onboard electronics, first connect the positive cable to the 12-V battery.

- Position negative cable ④ and mount and tighten the screw.

Guideline

Screw, battery terminal	M6	4.5 Nm (3.32 lbf ft)
-------------------------	----	-------------------------

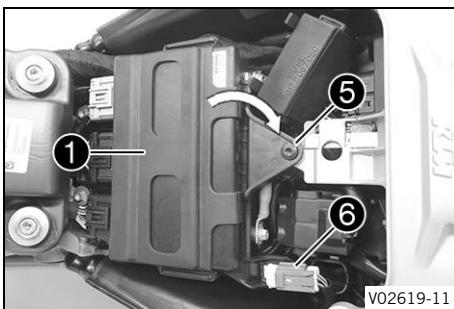

- Fold down cover ①.
- Mount and tighten screw ⑤.

Guideline

Remaining screws, chassis	M5	5 Nm (3.7 lbf ft)
---------------------------	----	-------------------

- Position diagnostics connector ⑥ in the bracket.

Finishing work

- Mount the front rider's seat. (📖 p. 92)
- Mount passenger seat. (📖 p. 91)
- Set time and date. (📖 p. 64)



16.8 Charging the 12-V battery 🔧



Warning

Risk of injury Battery acid and battery gases cause serious chemical burns.

- Keep 12 V batteries out of the reach of children.
- Wear suitable protective clothing and safety glasses.
- Avoid contact with battery acid and battery gases.
- Keep sparks or open flames away from the 12 V battery.
- Only charge 12 V batteries in well-ventilated rooms.
- Rinse the affected area immediately with plenty of water in the event of contact with the skin.
- Rinse eyes with water for at least 15 minutes and consult a doctor immediately if battery acid and battery gases get into the eyes.



Note

Environmental hazard 12 V batteries contain environmentally hazardous materials.

- Do not dispose of 12 V batteries as household waste.
- Dispose of 12 V batteries at a collection point for used batteries.



Note

Environmental hazard Hazardous substances cause environmental damage.

- Dispose of oils, grease, filters, fuel, cleaning agents, brake fluid, etc., correctly and in compliance with the applicable regulations.



Info

Even when there is no load on the 12-V battery, it discharges steadily each day.

The charging level and the method of charging are very important for the service life of the 12-V battery. Rapid recharging with a high charging current shortens the service life of the battery.

If the charging current, charging voltage, or charging time is exceeded, electrolyte escapes through the safety valves. This reduces the capacity of the 12-V battery.

If the 12-V battery is depleted by repeated starting, the 12-V battery must be charged immediately.

If the 12-V battery is left in a discharged state for an extended period, it will become deeply discharged and sulfating occurs, thus destroying the battery.

The 12-V battery is maintenance-free. The acid level does not have to be checked.

If the 12-V battery is not charged by the KTM battery charger, the 12-V battery must be removed for charging. Otherwise, overvoltage may damage electronic components. Charge the 12-V battery according to the instructions on the battery housing.

Preparatory work

- Remove the passenger seat. (📖 p. 91)
- Remove the front rider's seat. (📖 p. 92)

Main work

- Pull diagnostics connector **1** off the holder.
- Remove screw **2**.
- Lift cover **3** at the rear and pull toward the rear.
- Fold up cover.

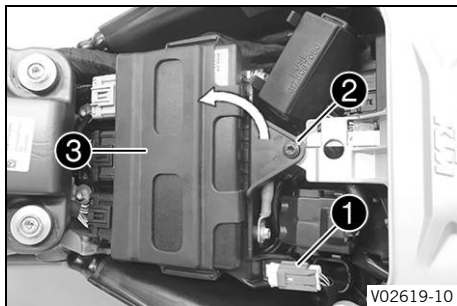

- Disconnect negative cable **4** from the 12-V battery.



Info

If the negative cable remains connected to the 12-V battery, damage to the onboard electronics is possible.

- Disconnect positive cable **5** from the 12-V battery.

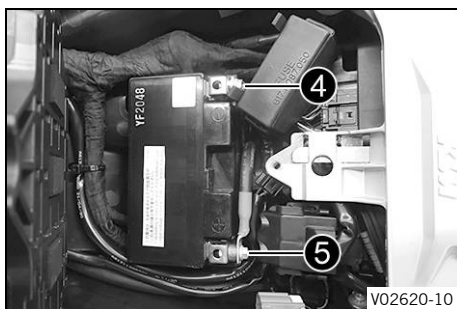

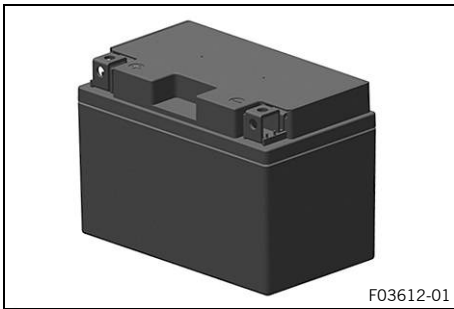

- Connect a battery charger to the 12-V battery. Connect the battery charger to the mains connection.

Battery charger (58429074200)

It is impossible to overcharge the 12-V battery using this battery charger.

This battery charger is not suitable for lithium-ion batteries.

i Info

Charge the 12-V battery to a maximum of 10 % of the capacity specified on the battery housing.

- Disconnect the battery charger from the mains connection and the 12-V battery after charging.

Guideline

The charging current, charging voltage, and charging time must not be exceeded.

Recharge the 12-V battery regularly when the motorcycle is not being used	3 months
---	----------

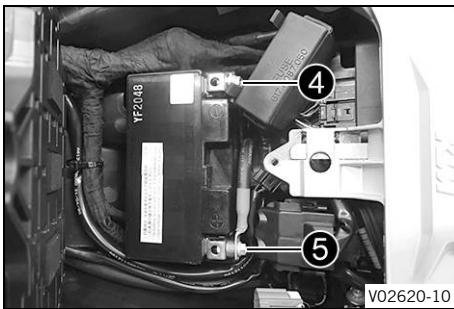

- Mount and tighten positive cable **5**.
- Position negative cable **4** and mount and tighten the screw.

Guideline

Screw, battery terminal	M6	4.5 Nm (3.32 lbf ft)
-------------------------	----	----------------------

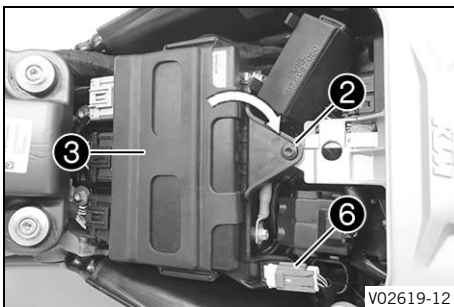

- Fold down cover **3**.
- Mount and tighten screw **2**.

Guideline

Remaining screws, chassis	M5	5 Nm (3.7 lbf ft)
---------------------------	----	-------------------

- Position diagnostics connector **6** in the bracket.

Finishing work

- Mount the front rider's seat. (📖 p. 92)
- Mount passenger seat. (📖 p. 91)
- Set time and date. (📖 p. 64)



16.9 Changing the RACE-ON key battery



Warning

Risk of injury Button cells may burst if misused.

Swallowing button cells leads to severe chemical burning and may result in death in under 2 hours.

- Keep button cells and the RACE-ON key out of the reach of children.
- Make sure the button cells can never be swallowed or ingested.
- Seek medical attention immediately if button cells are swallowed or ingested.
- Do not expose button cells to extreme temperatures or mechanical loads.
Permissible temperature -20 ... 50 °C (-4 ... 122 °F)
- Do not damage the RACE-ON key by e.g. cutting or squashing it.
- Do not use the RACE-ON key if the RACE-ON key is damaged or the battery compartment cannot be closed.
- Replace the RACE-ON key battery with the type specified only.

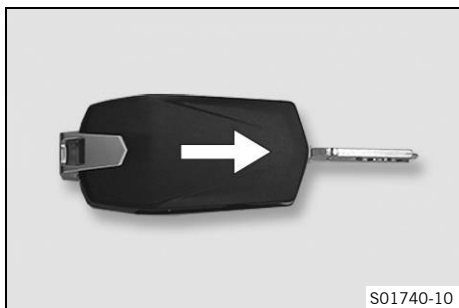

- Fold out the key bit of the RACE-ON key.
- Push lower half of the RACE-ON key in the direction of the arrow and take off.

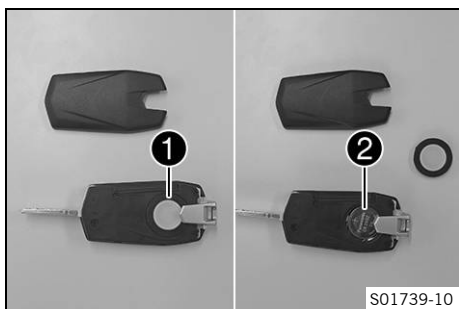

- Remove battery cover ①.
 - Remove RACE-ON key battery ②.
 - Insert new the RACE-ON key battery with label facing upward.
- RACE-ON key battery (CR 2032) (📖 p. 153)
- Mount battery cover ①.

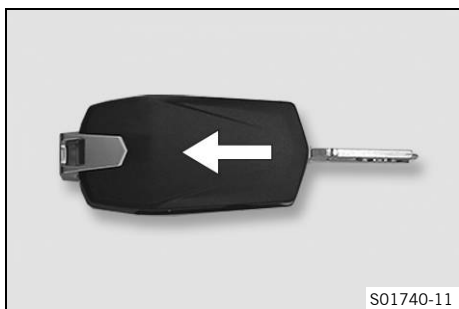

- Fit lower half of the RACE-ON key and snap into place in the direction of the arrow.

16.10 Changing the main fuse

**Warning****Fire hazard** Incorrect fuses overload the electrical system.

- Only use fuses with the required ampere value.
- Do not bypass or repair fuses.

Preparatory work

- Remove the passenger seat. (📖 p. 91)
- Remove the front rider's seat. (📖 p. 92)

Main work

- Take off protection cap ❶.

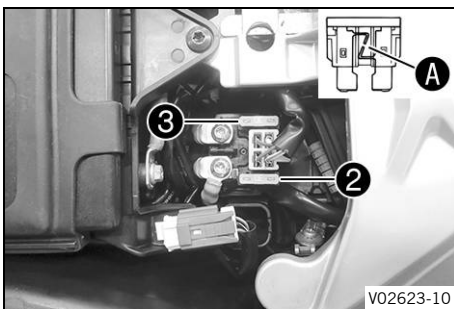
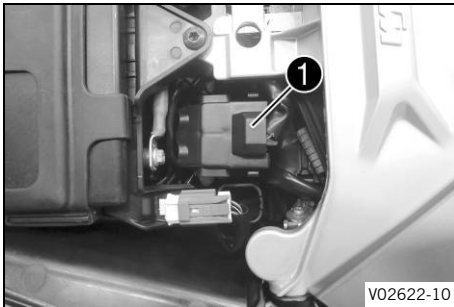

- Remove faulty main fuse ❷.

**Info**

A faulty fuse has a burned-out fuse wire A.

A spare fuse ❸ is located in the starter relay.

The main fuse protects all electrical power consumers of the vehicle.

- Insert a new main fuse.

Fuse (58011109130) (📖 p. 153)

- Check that the electrical system is functioning properly.
- Mount protection cap ❶.

**Tip**

Insert a new spare fuse into the starter relay to have it available when needed.

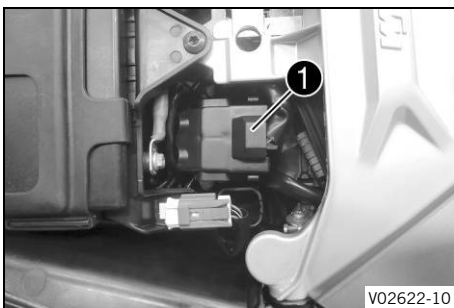
**Finishing work**

- Mount the front rider's seat. (📖 p. 92)
- Mount passenger seat. (📖 p. 91)
- Set time and date. (📖 p. 64)



16.11 Changing the fuses in the fuse box



Warning

Fire hazard Incorrect fuses overload the electrical system.

- Only use fuses with the required ampere value.
- Do not bypass or repair fuses.



Info

The fuse box containing the fuses of individual electrical power consumers is located under the seat.

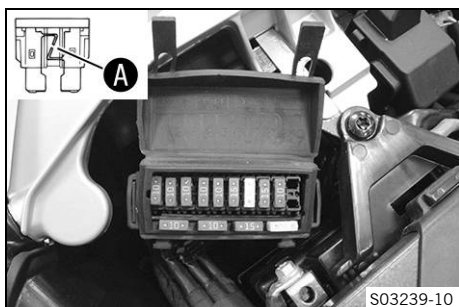
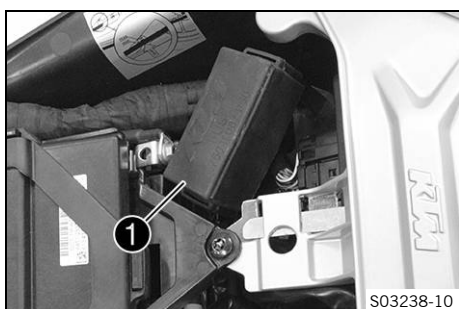

Preparatory work

- Remove the passenger seat. (📖 p. 91)
- Remove the front rider's seat. (📖 p. 92)

Main work

- Open fuse box cover ❶.

- Check the fuses.



Info

A faulty fuse has a burned-out fuse wire **A**.

- Remove the faulty fuse.

Guideline

Fuse 1 - 10 A - KTM RACE ON, combination instrument, exhaust valve control unit, connectivity unit, alarm system (optional)
Fuse 2 - 10 A - ACC 1
Fuse 3 - 10 A - tail light, license plate lamp
Fuse 4 - 10 A - light control unit
Fuse 5 - 10 A - engine control unit, fuel vapor valve, lambda sensors, SAS, ignition coils, injection valves
Fuse 6 - 15 A - semi-active suspension, cornering light
Fuse 7 - 25 A - ABS return pump
Fuse 8 - 15 A - ABS hydraulic unit
Fuse 9 - 10 A - ACC 2, USB-A charging socket
Fuses Spare - 10 A - Reserve
Fuse Spare - 15 A - Reserve
Fuse Spare - 25 A - Reserve

- Insert the spare fuse with the correct rating.

Fuse (58011109110) (📖 p. 153)
Fuse (58011109115) (📖 p. 153)

Fuse (58011109125) (📖 p. 153)

**Tip**

Insert a spare fuse so that it is available if needed.

- Check the function of the electrical power consumer.
- Close the fuse box cover.

Finishing work

- Mount the front rider's seat. (📖 p. 92)
- Mount passenger seat. (📖 p. 91)



16.12 Checking the setting of the lighting system

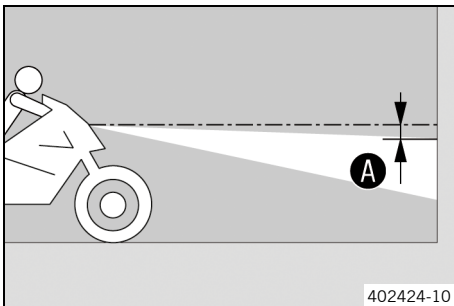

- Park vehicle on a horizontal surface in front of a light-colored wall and make a mark at the height of the center of the low beam headlight.

- Make a second mark at a distance **A** under the first mark.

Guideline

Distance A	5 cm (2 in)
-------------------	-------------

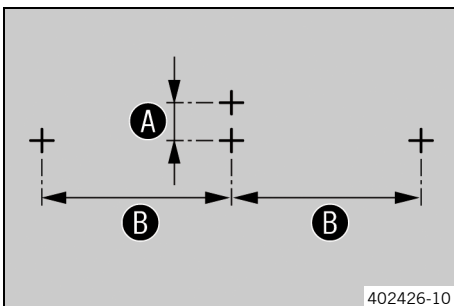

- Make two further marks spaced apart **B** to the left and the right of the second marking.

Guideline

Distance B	37 cm (14.6 in)
-------------------	-----------------

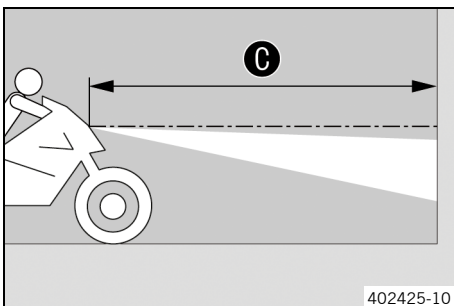

- Position the vehicle perpendicular to the wall at a distance **C** from the wall and switch on the low beam.

Guideline

Distance C	5 m (16 ft)
-------------------	-------------

- The rider now mounts the motorcycle with luggage and passenger if applicable.
- Check the headlight setting.

The light-dark boundary of the low beam must lie exactly on the lower mark when the motorcycle is ready for operation with the rider mounted along with any luggage and a passenger if applicable.
--

- » If the boundary between light and dark does not meet specifications:

- Adjust headlight range. (📖 p. 129)

- Press the **SET** button when the menu is closed.
- Press the **UP** or **DOWN** button until **Settings** is highlighted. Press the **SET** button to open the menu.

- Press the **UP** or **DOWN** button until **Corner. Light Test** is highlighted. Press the **SET** button to open the menu.
- Activate the menu item using the **UP** or **DOWN** button.



Info

The test is performed on the left cornering light in the menu item **Left**.

The test is performed on the right cornering light in the menu item **Right**.

The test is ended in the menu item **Off**.

- Press **SET** button, in order to perform the required test.



Info

The respective cornering light segments light up in succession, starting with the lower segment.

When the test of the respective cornering light is complete, the upper segment lights up continuously.

- Select left cornering light test and wait for a few seconds until the upper segment of the left cornering light lights up continuously.
- Check left cornering light setting.

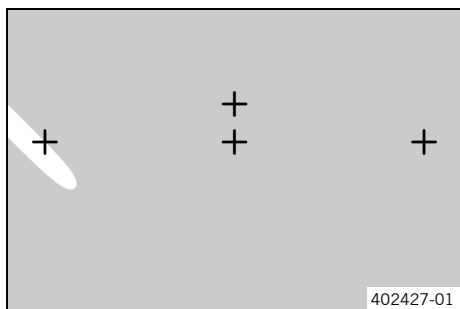

The light-dark boundary of the upper left segment must run exactly through the left marking.

- » If the boundary between light and dark does not meet specifications:

- Adjust cornering light range. (🗨️ p. 129)

- Press the **UP** or **DOWN** button to select the **Off** menu item and press the **SET** button to confirm the test.
- Select right cornering light test and wait for a few seconds until the upper segment of the right cornering light lights up continuously.

- Check right cornering light setting.

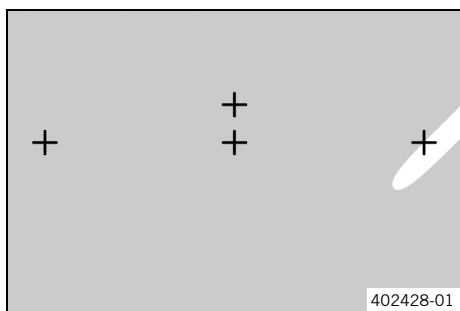

The light-dark boundary of the upper right segment must run exactly through the right marking.

- » If the boundary between light and dark does not meet specifications:

- Adjust cornering light range. (🗨️ p. 129)

- Press the **UP** or **DOWN** button to select the **Off** menu item and press the **SET** button to confirm the test.

16.13 Adjusting the headlight range

Preparatory work

- Check setting of the lighting system. (📖 p. 127)

Main work

- Turn adjusting screw ❶ to adjust the headlight range.



S03229-10

Info

Turn clockwise to increase the headlight range; turn counterclockwise to reduce the headlight range. If you have a payload, you may have to correct the headlight range.

- Set headlight to marking A.

Guideline

The light-dark boundary must lie exactly on lower marking A when the motorcycle is ready to operate with the rider mounted along with any luggage and a passenger if applicable.

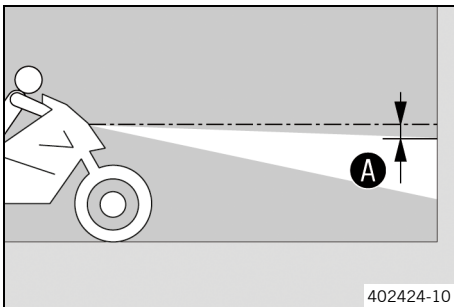

402424-10

16.14 Adjusting the cornering light range

Preparatory work

- Check setting of the lighting system. (📖 p. 127)

Main work

- Press the **SET** button when the menu is closed.
- Press the **UP** or **DOWN** button until **Settings** is highlighted. Press the **SET** button to open the menu.
- Press the **UP** or **DOWN** button until **Corner. Light Test** is highlighted. Press the **SET** button to open the menu.
- Activate the menu item using the **UP** or **DOWN** button.

Info

The test is performed on the left cornering light in the menu item **Left**.
The test is performed on the right cornering light in the menu item **Right**.
The test is ended in the menu item **Off**.

- Press **SET** button, in order to perform the required test.

Info

The respective cornering light segments light up in succession, starting with the lower segment. When the test of the respective cornering light is complete, the upper segment lights up continuously.

- Select left cornering light test and wait for a few seconds until the upper segment of the cornering light lights up continuously.

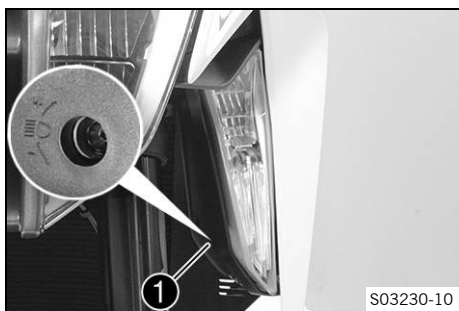

- Turn adjusting screw **1** to adjust the left cornering light range.

Guideline

Carefully turn the adjusting screw; do not use force to avoid damaging the adjuster mechanism.

Adjusting screw torque	$\leq 0.25 \text{ Nm}$ ($\leq 0.184 \text{ lbf ft}$)
------------------------	--

i Info

Turn clockwise to increase the headlight range; turn counterclockwise to reduce the headlight range. If you have a payload, you may have to correct the headlight range.

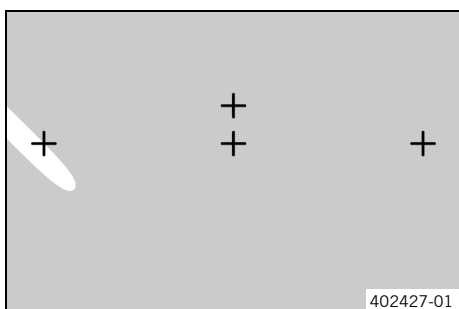

- Set upper segment on the left marking.

Guideline

The light-dark boundary of the upper segment must run exactly through the left marking.

- Press **UP** or **DOWN** button to select the menu item **Off** and press **SET** button to confirm the test.
- Select right cornering light test and wait for a few seconds until the upper segment of the cornering light lights up continuously.

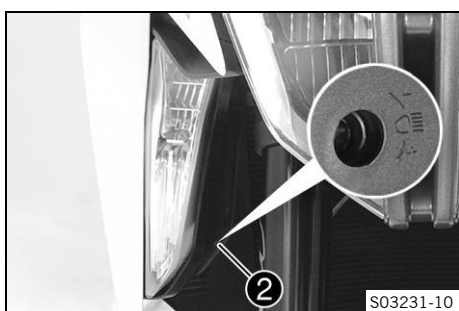

- Turn adjusting screw **2** to adjust the right cornering light range.

Guideline

Carefully turn the adjusting screw; do not use force to avoid damaging the adjuster mechanism.

Adjusting screw torque	$\leq 0.25 \text{ Nm}$ ($\leq 0.184 \text{ lbf ft}$)
------------------------	--

i Info

Turn clockwise to increase the headlight range; turn counterclockwise to reduce the headlight range. If you have a payload, you may have to correct the headlight range.

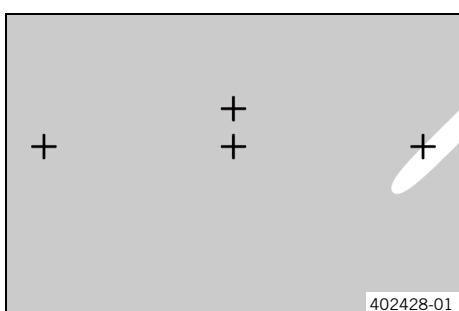

- Set upper segment on the right marking.

Guideline

The light-dark boundary of the upper segment must run exactly through the right marking.

- Press **UP** or **DOWN** button to select the menu item **Off** and press **SET** button to confirm the test.

16.15 Diagnostics connector

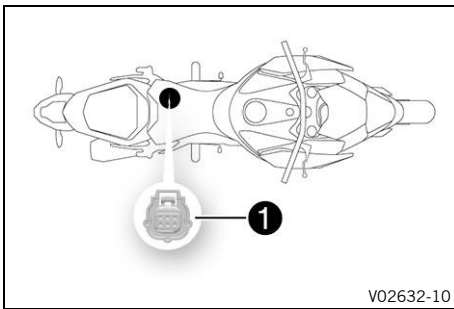

Diagnostics connector **1** is located under the front rider's seat.

16.16 Front ACC1 and ACC2

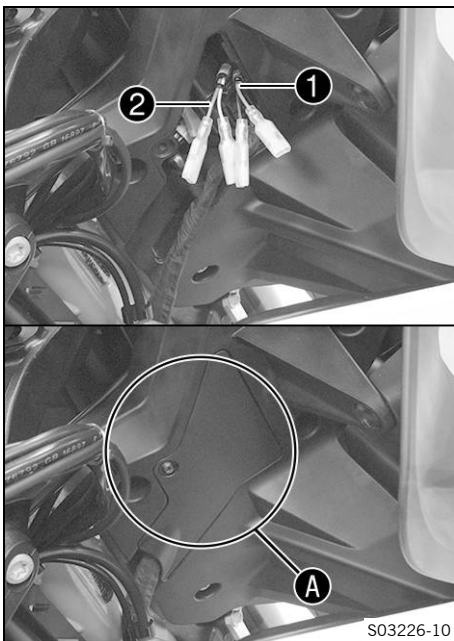

The front power supplies ACC1 **1** and ACC2 **2** are located on the right side of the instrument support behind a cover **A**.

16.17 ACC1 and ACC2 rear

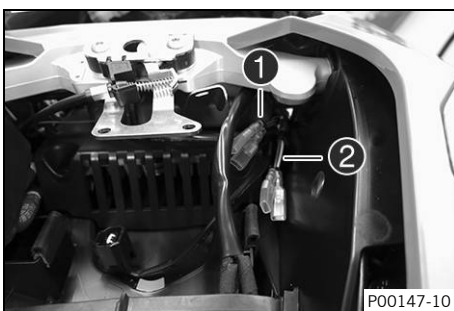

The rear power supplies ACC1 **1** and ACC2 **2** are located on the right next to the passenger seat lock.

17.1 Checking the coolant level in the compensating tank



Warning

Danger of scalding During motorcycle operation, the coolant gets very hot and is under pressure.

- Do not open the radiator, the radiator hoses or other cooling system components if the engine or the cooling system are at operating temperature.
- Allow the cooling system and the engine to cool down before you open the radiator, the radiator hoses or other components of the cooling system.
- In the event of scalding, rinse the area affected immediately with lukewarm water.



Warning

Danger of poisoning Coolant is toxic and a health hazard.

- Keep coolant out of the reach of children.
- Do not allow coolant to come into contact with the skin, the eyes and clothing.
- Consult a doctor immediately if coolant is swallowed.
- Rinse the affected area immediately with plenty of water in the event of contact with the skin.
- Rinse eyes thoroughly with water and consult a doctor immediately if coolant gets into the eyes.
- Change clothing if coolant spills onto your clothing.

Condition

The engine is cold.

The radiator is completely full.

- Stand motorcycle upright on a horizontal surface.
- Check coolant level in compensating tank ① on the right-hand side.

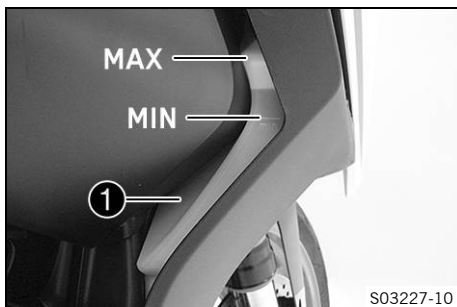

The coolant level must be between **MIN** and **MAX**.

- » If there is no coolant in the compensating tank:
 - Check the cooling system for leaks. 🛠️



Info

Do not start the motorcycle!

- Add the coolant/bleed the cooling system. 🛠️
- » If the coolant level in the compensating tank is not at the required level, but the tank is not empty:
 - Correct the coolant level in the compensating tank. (📖 p. 132)

17.2 Correcting the coolant level in the compensating tank



Warning

Danger of scalding During motorcycle operation, the coolant gets very hot and is under pressure.

- Do not open the radiator, the radiator hoses or other cooling system components if the engine or the cooling system are at operating temperature.
- Allow the cooling system and the engine to cool down before you open the radiator, the radiator hoses or other components of the cooling system.
- In the event of scalding, rinse the area affected immediately with lukewarm water.



Warning

Danger of poisoning Coolant is toxic and a health hazard.

- Keep coolant out of the reach of children.
- Do not allow coolant to come into contact with the skin, the eyes and clothing.
- Consult a doctor immediately if coolant is swallowed.
- Rinse the affected area immediately with plenty of water in the event of contact with the skin.
- Rinse eyes thoroughly with water and consult a doctor immediately if coolant gets into the eyes.
- Change clothing if coolant spills onto your clothing.

Condition

The engine is cold.
The radiator is completely full.

Preparatory work

- Check coolant level in the compensating tank. (📖 p. 132)

Main work

- Remove fuel tank spoiler. (📖 p. 100)



Info

Only disassemble the right-hand side.

- Remove cover ❶ of the compensating tank.
- Add coolant to the **MAX** marking.

Coolant (📖 p. 161)

- Mount cover ❶ of the compensating tank.

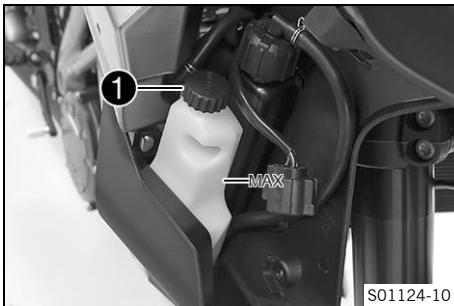

Finishing work

- Install the fuel tank spoiler. (📖 p. 101)



18.1 Ride Mode



Possible states

- **Street** – Homologated performance with balanced response; the motorcycle traction control allows normal slip on the rear wheel.
- **Sport** – Homologated performance with very direct response; the motorcycle traction control allows greater slip on the rear wheel.
- **Rain** – Homologated performance with soft response for improved rideability; the motorcycle traction control allows less slip on the rear wheel.
- **Track** (optional) – Homologated performance and extremely direct response. The motorcycle traction control and the characteristics of the throttle response can be set individually.

Various vehicle tunings can be selected in the **Ride Mode** menu.

Track (optional), **Sport**, **Street** and **Rain** are available.

The riding mode selected last appears in the display.

The riding mode can also be changed while riding with a closed throttle and deactivated cruise control.

18.2 Motorcycle traction control (MTC)



The motorcycle traction control (**MTC**) lowers the engine torque in case of loss of traction in the rear wheel.

Depending on the riding mode (📖 p. 134), different amounts of slip are allowed when traction control is activated.

i Info

When motorcycle traction control is switched off, the rear wheel may spin during strong acceleration and on surfaces with low grip, resulting in a risk of crashing. After the ignition is switched on, motorcycle traction control is enabled again.

The motorcycle traction control is adjusted using the **Motorcycle** menu on the combination instrument. The motorcycle traction control can be switched off in the **MTC** menu.

i Info

When the motorcycle traction control is active, the TC indicator lamp 🚦 flashes. When motorcycle traction control is switched off, the TC indicator lamp 🚦 lights up.

18.3 Slip adjustment (optional)

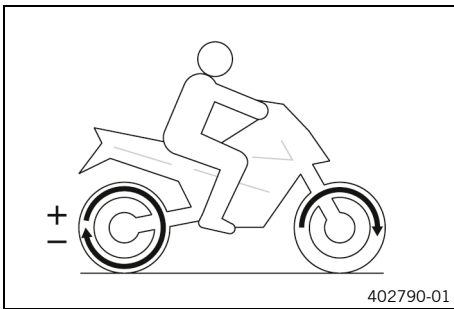

The slip adjustment is a motorcycle traction control function. The slip adjustment allows the motorcycle traction control to be tuned through nine levels to the desired characteristic map. Level 1 allows the maximum slip on the rear wheel, and level 9 the minimum. The spin adjuster can be set when the cruise control is deactivated using the **+RES** or **-SET** button.

i Info

The spin adjuster is only available in **Track** riding mode (optional).

18.4 Throttle Response (optional)



Possible states

- Track – Extremely direct response
- Sport – Very direct response
- Street – Balanced response

In the combination instrument the characteristics of the throttle response can be adjusted via the **Throttle Response** submenu. The **Throttle Response** can also be set while riding with a closed throttle grip.

i Info

Throttle Response is only available in **Track** riding mode (optional).

19.1 Checking the engine oil level

i Info

Oil consumption depends on the riding style and the operating conditions.

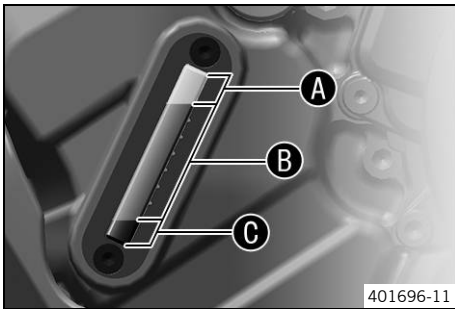

Condition

The engine is at operating temperature.

Preparatory work

- Stand the motorcycle upright on a horizontal surface.

Main work

- Check the engine oil level in the engine oil level viewer.

i Info

After switching off the engine, wait one minute before checking the level.

The engine oil level should be in the upper area **B** of the engine oil level viewer.

- » When the engine oil level is in area **A** of the engine oil level viewer:
 - Do not add engine oil.
- » When the engine oil level is in area **B** of the engine oil level viewer:
 - Engine oil can be added.
- » When the engine oil level is in area **C** of the engine oil level viewer:
 - Add engine oil. (📖 p. 139)

19.2 Changing the engine oil and oil filter, cleaning the oil screens

! Warning

Danger of scalding Engine and gear oil get very hot when the motorcycle is ridden.

- Wear suitable protective clothing and safety gloves.
- In the event of scalding, rinse the area affected immediately with lukewarm water.



Note

Environmental hazard Hazardous substances cause environmental damage.

- Dispose of oils, grease, filters, fuel, cleaning agents, brake fluid, etc., correctly and in compliance with the applicable regulations.

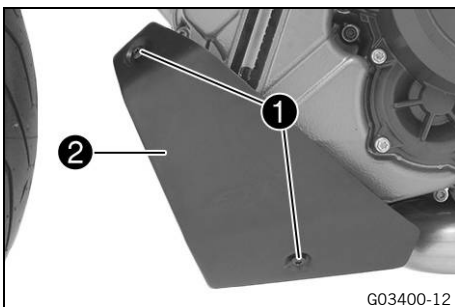

Main work

- Stand the motorcycle on a level surface using the side stand.
- Remove screws **1**.
- Take off plate **2**.

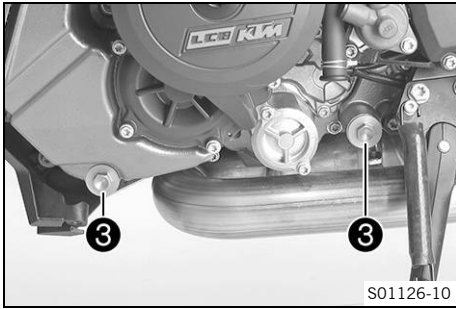

- Position an appropriate container under the engine.
- Remove oil drain plugs **3** along with the magnets, the O-rings, and the oil screens.

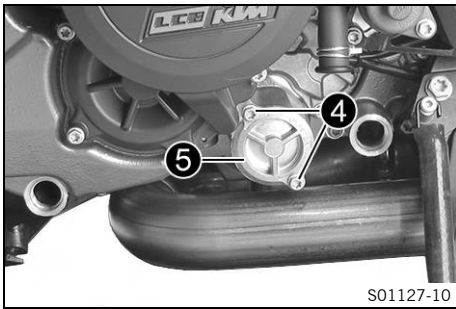

- Remove screws **4**. Take off oil filter cover **5** with the O-ring.

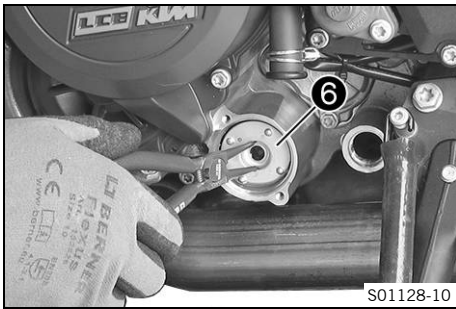

- Pull oil filter **6** out of the oil filter housing.

Lock ring plier (51012011000)

- Allow the engine oil to drain completely.
- Thoroughly clean the parts and the sealing surfaces.

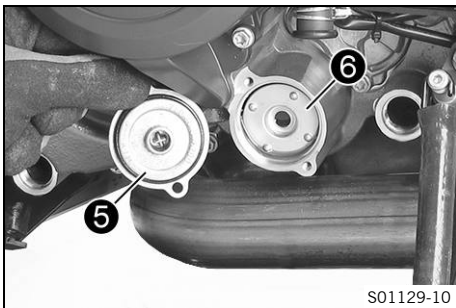

- Insert new oil filter **6**.

i **Info**
Only insert the oil filter by hand.

- Oil the O-ring of the oil filter cover. Mount oil filter cover **5**.

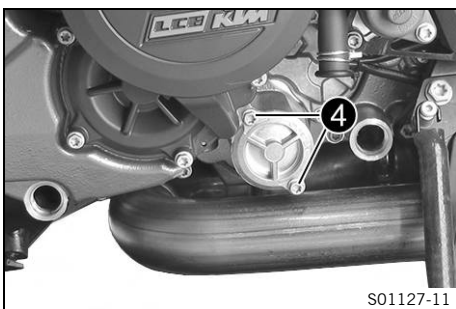

- Mount and tighten screws **4**.

Guideline

Remaining engine screws	M5	6 Nm (4.4 lbf ft)
-------------------------	----	-------------------

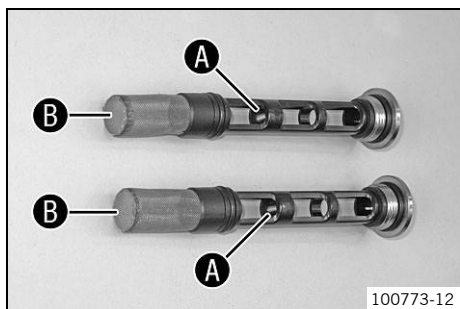

- Thoroughly clean magnets **A** and oil screens **B** of the oil drain plugs.

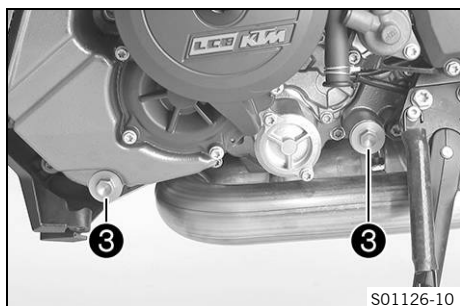

- Mount and tighten oil drain plugs **3** with magnets, O-rings, and oil screens.

Guideline

Oil drain plug	M20x1.5	20 Nm (14.8 lbf ft)
----------------	---------	---------------------

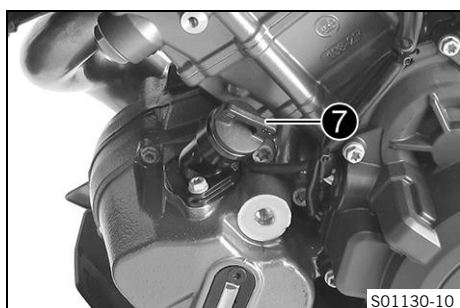

- Have the entire filling quantity available.

Engine oil Ambient temperature: $\geq 0\text{ }^{\circ}\text{C}$ ($\geq 32\text{ }^{\circ}\text{F}$)	3.50 l (3.7 qt.)	Engine oil (SAE 10W/50) (📖 p. 161)
Engine oil Ambient temperature: $< 0\text{ }^{\circ}\text{C}$ ($< 32\text{ }^{\circ}\text{F}$)		Engine oil (SAE 5W/40) (📖 p. 162)

- Add the oil quantity in two steps.
- Remove filler plug **7** with the O-ring, and fill up with the first partial quantity.

Engine oil (1st partial quantity) approx. Ambient temperature: $\geq 0\text{ }^{\circ}\text{C}$ ($\geq 32\text{ }^{\circ}\text{F}$)	3.0 l (3.2 qt.)	Engine oil (SAE 10W/50) (📖 p. 161)
Engine oil (1st partial quantity) approx. Ambient temperature: $< 0\text{ }^{\circ}\text{C}$ ($< 32\text{ }^{\circ}\text{F}$)		Engine oil (SAE 5W/40) (📖 p. 162)

- Mount filler plug **7** with the O-ring.



Danger

Danger of poisoning Exhaust gases are toxic and inhaling them may result in unconsciousness and death.

- Always make sure there is sufficient ventilation when running the engine.
- Use effective exhaust extraction when starting or running the engine in an enclosed space.

- Start the engine and check it for leaks.
- Switch off the engine.
- Remove the filler plug with the O-ring and add the second partial quantity up to the upper marking **A** on the engine oil level viewer.

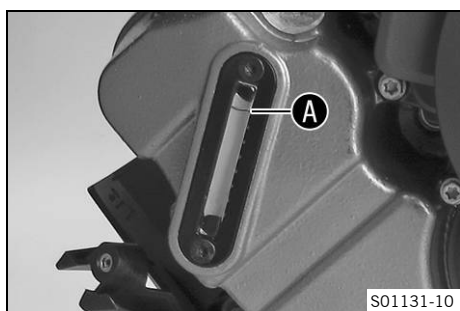

Engine oil (2nd partial quantity) approx. Ambient temperature: $\geq 0\text{ }^{\circ}\text{C}$ ($\geq 32\text{ }^{\circ}\text{F}$)	0.50 l (0.53 qt.)	Engine oil (SAE 10W/50) (📖 p. 161)
Engine oil (2nd partial quantity) approx. Ambient temperature: $< 0\text{ }^{\circ}\text{C}$ ($< 32\text{ }^{\circ}\text{F}$)		Engine oil (SAE 5W/40) (📖 p. 162)

- Mount the filler plug with the O-ring.



Danger

Danger of poisoning Exhaust gases are toxic and inhaling them may result in unconsciousness and death.

- Always make sure there is sufficient ventilation when running the engine.
- Use effective exhaust extraction when starting or running the engine in an enclosed space.

- Start the engine and check it for leaks.
- Switch off the engine.
- Position plate **2**.
- Mount and tighten screws **1**.

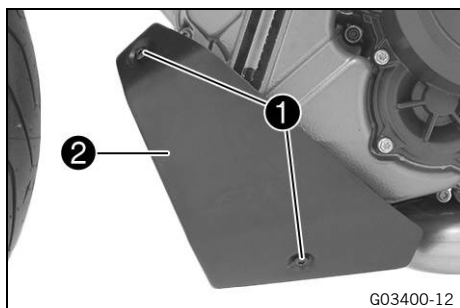

Guideline

Remaining screws, chassis	M5	5 Nm (3.7 lbf ft)
---------------------------	----	-------------------

Finishing work

- Check the engine oil level. (📖 p. 136)



19.3 Adding engine oil

Info

Too little engine oil or poor-quality engine oil results in premature wear to the engine. The engine may be damaged if the engine oil level is too high.

Condition

The engine is at operating temperature.

Preparatory work

- Stand the motorcycle upright on a horizontal surface.

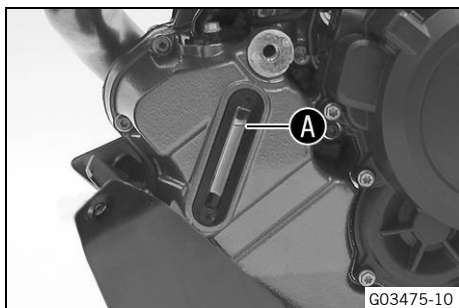
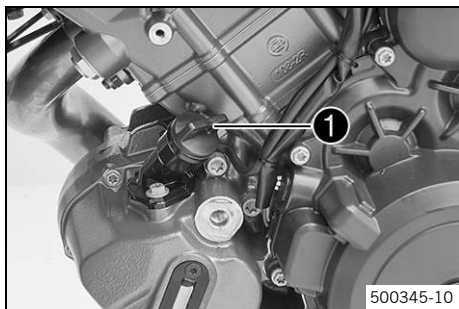

- Check the engine oil level. (📖 p. 136)

Main work

- Remove filler plug ❶ with the O-ring.

- Add the engine oil to upper marking A on the engine oil level viewer.

Condition

Ambient temperature: $\geq 0\text{ }^{\circ}\text{C}$ ($\geq 32\text{ }^{\circ}\text{F}$)

Engine oil (SAE 10W/50) (📖 p. 161)

Condition

Ambient temperature: $< 0\text{ }^{\circ}\text{C}$ ($< 32\text{ }^{\circ}\text{F}$)

Engine oil (SAE 5W/40) (📖 p. 162)

Info

In order to achieve optimal engine oil performance, it is not advisable to mix different engine oils. KTM recommends changing the engine oil where necessary.

- Mount the filler plug with the O-ring.



Danger

Danger of poisoning Exhaust gases are toxic and inhaling them may result in unconsciousness and death.

- Always make sure there is sufficient ventilation when running the engine.
- Use effective exhaust extraction when starting or running the engine in an enclosed space.

- Start the engine and check for leaks.

Finishing work

- Check the engine oil level. (📖 p. 136)

20.1 Cleaning the motorcycle

Note

Material damage Components become damaged or destroyed if a pressure cleaner is used incorrectly. The high pressure forces water into the electrical components, connectors, throttle cables, and bearings, etc. Pressure which is too high causes malfunctions and destroys components.

- Do not direct the water jet directly on to electrical components, connectors, throttle cables or bearings.
- Maintain a minimum distance between the nozzle of the pressure cleaner and the component.

Minimum clearance 60 cm (23.6 in)



Note

Environmental hazard Hazardous substances cause environmental damage.

- Dispose of oils, grease, filters, fuel, cleaning agents, brake fluid, etc., correctly and in compliance with the applicable regulations.



Info

Clean the motorcycle regularly to maintain its value and appearance over a long period. Avoid direct sunshine when cleaning the motorcycle.

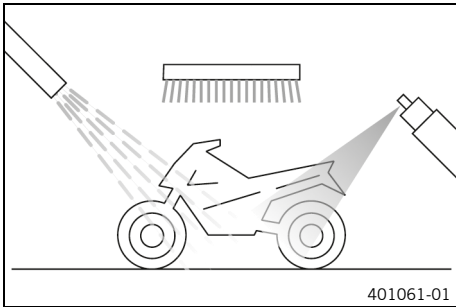

- Close off exhaust system to keep water from entering.
- Remove the coarse dirt particles with a gentle water jet.
- Spray the heavily soiled parts with a normal commercial motorcycle cleaner and clean using a brush.

Motorcycle cleaner (📖 p. 163)



Info

Use warm water containing normal motorcycle cleaner and a soft sponge. Never apply motorcycle cleaner to a dry vehicle; always rinse the vehicle with water first. If the vehicle has been used on salted roads, use cold water for cleaning after riding. Warm water enhances the corrosive effects of salt.

- After rinsing the motorcycle with a gentle spray of water, allow it to dry thoroughly.
- Remove the closure of the exhaust system.



Warning

Danger of accidents Moisture and dirt impair the brake system.

- Brake carefully several times to dry out and remove dirt from the brake linings and the brake discs.

- After cleaning, ride the vehicle a short distance until the engine warms up.



Info

The heat produced causes water at inaccessible locations in the engine and on the brake system to evaporate.

- Push back the protection caps of the handlebar controls to allow any water that has penetrated to evaporate.
- After the motorcycle has cooled down, lubricate all moving parts and pivot points.
- Clean the chain. (📖 p. 95)
- Treat bare metal (except for brake discs and the exhaust system) with a corrosion inhibitor.

Preserving materials for paints, metal and rubber (📖 p. 163)

- Treat the painted parts with a mild paint polish.

Perfect finish and high gloss polish for paints (📖 p. 163)

i Info

Do not polish parts that were matte when delivered as this would strongly impair the material quality.

- Treat the plastic parts and powder-coated parts with a mild cleaning and care product.

Special cleaner for glossy and matte paint finishes, metal and plastic surfaces (📖 p. 163)

- Oil steering lock and seat lock.

Universal oil spray (📖 p. 163)

20.2 Checks and maintenance steps for winter operation

i Info

If you use the motorcycle in winter, you must expect salt on the roads. You should therefore take precautions against aggressive road salt. If the vehicle has been used on salted roads, use cold water for cleaning after riding. Warm water enhances the corrosive effects of salt.

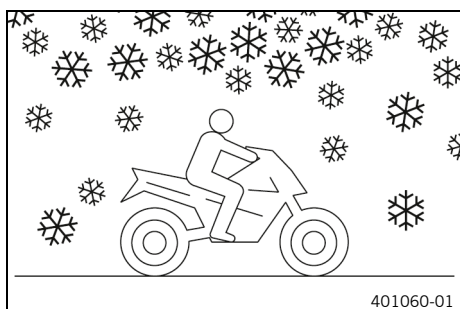

- Clean the motorcycle. (📖 p. 141)
- Clean the brakes.

i Info

After **EVERY** trip on salted roads, thoroughly clean the brake calipers and brake linings, after they have cooled down and without removing them, with cold water and dry them carefully. After riding on salted roads, thoroughly clean the motorcycle with cold water and dry it well.

- Treat the engine, the link fork, and all other bare or zinc-plated parts (except the brake discs) with a wax-based corrosion inhibitor.

i Info

Corrosion inhibitor must not come into contact with the brake discs. This would severely lower the braking effect.

- Clean the chain. (📖 p. 95)



21.1 Storage

i Info

If the motorcycle is not being used for an extended length of time, additional measures are recommended. Before storing the motorcycle, check all parts for function and wear. If service, repairs, or replacements are necessary, you should do this during the storage period (less workshop overload). This allows you to avoid long waiting periods when the next season starts.

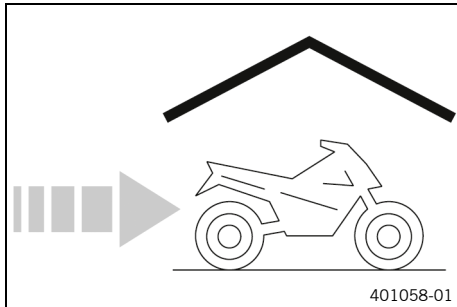

- When refueling for the last time before taking the motorcycle out of service, add fuel additive.

Fuel additive (📖 p. 163)

- Refuel. (📖 p. 85)
- Clean the motorcycle. (📖 p. 141)
- Change the engine oil and the oil filter, clean the oil screens. 🛠️ (📖 p. 136)
- Check the coolant fill level and antifreeze. 🛠️
- Check tire pressure. (📖 p. 116)
- Remove the 12-V battery. 🛠️ (📖 p. 119)

Guideline

Storage temperature of the 12-V battery without direct sunlight	0 ... 35 °C (32 ... 95 °F)
---	----------------------------

- Charge the 12-V battery. 🛠️ (📖 p. 121)
- Store the vehicle in a dry location that is not subject to large fluctuations in temperature.

i Info

KTM recommends jacking up the motorcycle.

- Raise the motorcycle with the rear lifting gear. (📖 p. 90)
- Lift the motorcycle with the front lifting gear. (📖 p. 90)
- Cover the motorcycle with a tarp or cover that is permeable to air.

i Info

Do not use non-porous materials since they prevent humidity from escaping, thus causing corrosion. Avoid running the engine for a short time only. Since the engine cannot warm up properly, the water vapor produced during combustion condenses and causes valves and the exhaust system to rust.

21.2 Preparing for use after storage

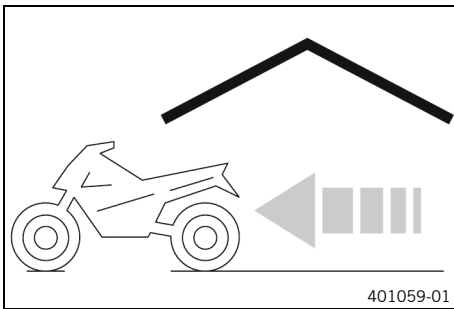

- Take the motorcycle off the front lifting gear. (📖 p. 91)
- Remove the rear of the motorcycle from the lifting gear. (📖 p. 90)
- Install the 12-V battery. 🔧 (📖 p. 120)



Info

If the 12-V battery was removed, the time and date must be set.

- Perform checks and maintenance measures when preparing for use. (📖 p. 75)
- Take a test ride.





The RACE ON indicator light **1** can indicate malfunctions by flashing. These are indicated up to five seconds after the RACE ON button is actuated.

i Info
Blink codes referring to **KTM RACE ON** are only displayed once and are not repeated.

Faults	Possible cause	Action
No response if the RACE-ON button is pressed	RACE-ON button faulty	<ul style="list-style-type: none"> – Check the RACE-ON button for damage. – Check the cable and the plug of the RACE-ON button for damage.
RACE-ON indicator lamp flashes twice	No response signal from the RACE-ON key	<ul style="list-style-type: none"> – Ensure that the RACE-ON key is in range. – Remove other electronic devices from the vicinity of the RACE-ON antenna. – Check the battery compartment in the RACE-ON key for correct locking. – Check the battery compartment of the RACE-ON key for corrosion. – Change the RACE-ON key battery. (📖 p. 124) – Use black ignition key.
RACE-ON indicator lamp flashes three times	12-V battery discharged	<ul style="list-style-type: none"> – Charge the 12-V battery. (📖 p. 121) – Check the open-circuit current. (🔧)
RACE-ON indicator lamp flashes four times	Steering lock bolt locked or tense	<ul style="list-style-type: none"> – Move handlebar slightly.
RACE-ON indicator lamp flashes five times	RACE-ON antenna faulty	<ul style="list-style-type: none"> – Check the RACE-ON antenna for damage.
The combination instrument shows nothing in the display	Fuse 1 is blown	<ul style="list-style-type: none"> – Change the fuses in the fuse box. (📖 p. 126)
	The main fuse is blown	<ul style="list-style-type: none"> – Change the main fuse. (📖 p. 125)
	12-V battery discharged	<ul style="list-style-type: none"> – Charge the 12-V battery. (📖 p. 121) – Check the open-circuit current. (🔧)
Engine does not rotate if the start button/emergency OFF switch is pressed into the lower position	Operating error	<ul style="list-style-type: none"> – Carry out start procedure. (📖 p. 75)
	12-V battery discharged	<ul style="list-style-type: none"> – Charge the 12-V battery. (📖 p. 121) – Check the open-circuit current. (🔧)
	Faulty safety starting system	<ul style="list-style-type: none"> – Read out the fault memory using the KTM diagnostics tool. (🔧)
The engine only turns if the clutch lever is drawn	Electronic fault	<ul style="list-style-type: none"> – Read out the fault memory using the KTM diagnostics tool. (🔧)
	The vehicle is in gear	<ul style="list-style-type: none"> – Shift the transmission into neutral N.
The engine turns although a gear is engaged	Faulty safety starting system	<ul style="list-style-type: none"> – Read out the fault memory using the KTM diagnostics tool. (🔧)
	Faulty safety starting system	<ul style="list-style-type: none"> – Read out the fault memory using the KTM diagnostics tool. (🔧)

Faults	Possible cause	Action
The engine turns but does not start	Quick release coupling not joined	– Join the quick release coupling.
	Malfunction in the electronic fuel injection	– Read out the fault memory using the KTM diagnostics tool. 🛠️
	The fuel quality is insufficient	– Add suitable fuel.
The engine dies during the trip	Lack of fuel	– Refuel. (📖 p. 85)
	Malfunction in the electronic fuel injection	– Read out the fault memory using the KTM diagnostics tool. 🛠️
Malfunction indicator lamp lights up or flashes	Malfunction in the electronic fuel injection	– Read out the fault memory using the KTM diagnostics tool. 🛠️
The ABS warning lamp lights up	ABS fuse blown	– Change the fuses in the fuse box. (📖 p. 126)
	Large difference in wheel speeds of the front and rear wheels	– Stop the vehicle, switch off the ignition, and start it again.
	Malfunction in ABS	– Read out the fault memory using the KTM diagnostics tool. 🛠️
High oil consumption	The engine oil level is too high	– Check the engine oil level. (📖 p. 136)
	The engine oil is too thin (low viscosity)	– Change the engine oil and the oil filter, clean the oil screens. 🛠️ (📖 p. 136)
12-V battery discharged	The hazard warning flasher is switched on	– Switch off the hazard warning flasher. – Charge the 12-V battery. 🛠️ (📖 p. 121)
	The 12-V battery is not being charged by the alternator	– Check charging voltage. 🛠️
	The ignition was not switched off while the vehicle was parked	– Charge the 12-V battery. 🛠️ (📖 p. 121)

23.1 Engine

Design	2-cylinder 4-stroke Otto engine, 75° V arrangement, water-cooled
Displacement	1,301 cm ³ (79.39 cu in)
Stroke	71 mm (2.8 in)
Bore	108 mm (4.25 in)
Compression ratio	13.6:1
Idle speed	1,350 ... 1,550 rpm
Control	DOHC, 4 valves per cylinder, chain-driven
Valve - valve plate diameter	
Intake	42 mm (1.65 in)
Exhaust	34 mm (1.34 in)
Valve clearance	
Exhaust at: 20 °C (68 °F)	0.25 ... 0.30 mm (0.0098 ... 0.0118 in)
Intake at: 20 °C (68 °F)	0.10 ... 0.15 mm (0.0039 ... 0.0059 in)
Crankshaft bearing	Sleeve bearing
Conrod bearing	Sleeve bearing
Piston	Forged light alloy
Piston ring	1 upper compression (rectangular) ring, 1 lower compression ring, 1 oil scraper ring
Engine lubrication	Dry sump lubrication system with 3 trochoidal pumps
Primary transmission	40:76
Clutch	Antihopping clutch in oil bath/hydraulically operated
Transmission	6-gear transmission, claw shifted
Transmission ratio	
1st gear	12:35
2nd gear	15:32
3rd gear	18:30
4th gear	20:27
5th gear	24:27
6th gear	27:26
Mixture preparation	Electronic fuel injection
Ignition system	Contactless controlled fully electronic ignition with digital ignition adjustment
Alternator	12 V, 450 W
Spark plug	
Inside spark plug	NGK LKAR9BI-10
Outside spark plug	NGK LMAR7DI-10
Electrode gap, spark plug	1 mm (0.04 in)
Cooling	Water cooling, permanent circulation of coolant by water pump
Cold start device	Starter motor

23.2 Engine tightening torques



Screw, air filter box cover, long	EJOT Delta PT® 60x30	2.5 Nm (1.84 lbf ft)
Screw, damping plate	EJOT ALtracs® M6x14	14 Nm (10.3 lbf ft) Loctite®243™
Screw, intake air temperature sensor	EJOT PT® K50x16	2 Nm (1.5 lbf ft)
Screw, retaining bracket, valve cover, rear	EJOT ALtracs® M6x12	8 Nm (5.9 lbf ft)
Screw, SAS plate on air filter box	EJOT PT® K50x16	2 Nm (1.5 lbf ft)
Hose clip, intake flange	M4	1.5 Nm (1.11 lbf ft)
Oil nozzle	M5	2 Nm (1.5 lbf ft) Loctite®243™
Remaining engine screws	M5	6 Nm (4.4 lbf ft)
Screw, bearing retainer	M5	5 Nm (3.7 lbf ft) Loctite®243™
Screw, bearing shells retaining bracket	M5	6 Nm (4.4 lbf ft) Loctite®243™
Screw, cable duct on the engine fixing arm	M5x12	5 Nm (3.7 lbf ft)
Screw, crankshaft speed sensor	M5	6 Nm (4.4 lbf ft) Loctite®243™
Screw, engine oil level viewer	M5	4 Nm (3 lbf ft) Loctite®243™
Screw, gear position sensor	M5	5 Nm (3.7 lbf ft) Loctite®243™
Screw, resonator	M5	8 Nm (5.9 lbf ft) Loctite®243™
Screw, shift shaft sensor	M5	5 Nm (3.7 lbf ft) Loctite®243™
Swing angle sensor screw	M5	5 Nm (3.7 lbf ft) Loctite®243™
Bleeder screw, water pump cover	M6	10 Nm (7.4 lbf ft)
Coolant connection screw on the cylinder head	M6	8 Nm (5.9 lbf ft) Loctite®243™
Freewheel ring bolt	M6 – 10.9	15 Nm (11.1 lbf ft) Loctite® 648™
Nut, cylinder head	M6	8 Nm (5.9 lbf ft)
Nut, starter cable	M6	4 Nm (3 lbf ft)
Remaining engine screws	M6	10 Nm (7.4 lbf ft)
Screw plug, vacuum connection	M6	2.5 Nm (1.84 lbf ft) Loctite®243™
Screw, camshaft bearing support	M6 – 10.9	10 Nm (7.4 lbf ft)
Screw, clutch cover	M6	10 Nm (7.4 lbf ft)
Screw, clutch spring	M6	12 Nm (8.9 lbf ft)
Screw, engine case	M6x60	10 Nm (7.4 lbf ft)
Screw, engine case	M6x80	10 Nm (7.4 lbf ft)
Screw, engine case	M6x90	10 Nm (7.4 lbf ft)

Screw, kickstarter gear support	M6	10 Nm (7.4 lbf ft) Loctite®243™
Screw, locking lever	M6	10 Nm (7.4 lbf ft) Loctite®243™
Screw, oil filler neck	M6x20	10 Nm (7.4 lbf ft) Loctite®243™
Screw, oil pump cover	M6	10 Nm (7.4 lbf ft) Loctite®243™
Screw, oil/water heat exchanger	M6	10 Nm (7.4 lbf ft) Loctite®243™
Screw, SAS flange	M6x12	10 Nm (7.4 lbf ft)
Screw, shift lever	M6	18 Nm (13.3 lbf ft) Loctite®243™
Screw, shift star	M6 – 12.9	15 Nm (11.1 lbf ft) Loctite®243™
Screw, starter motor	M6	10 Nm (7.4 lbf ft)
Screw, stator	M6	10 Nm (7.4 lbf ft) Loctite®243™
Screw, stick coil	M6	8 Nm (5.9 lbf ft)
Screw, swingarm sensor	M6x20	10 Nm (7.4 lbf ft) Loctite®243™
Screw, valve cover	M6	10 Nm (7.4 lbf ft)
Screw, water pump cover	M6	10 Nm (7.4 lbf ft)
Screw, water pump wheel	M6	10 Nm (7.4 lbf ft) Loctite®243™
Stud, timing chain shaft	M6	3 Nm (2.2 lbf ft)
Clutch lubricating jet	M6x0.75	2 Nm (1.5 lbf ft)
Nozzle 100 for crankcase ventilation	M6x0.75	3 Nm (2.2 lbf ft) Loctite®243™
Crankshaft locking bolt	M8	12 Nm (8.9 lbf ft)
Screw, camshaft bearing support	M8 – 10.9	Step 1 10 Nm (7.4 lbf ft) Step 2 18 Nm (13.3 lbf ft)
Screw, engine case	M8	18 Nm (13.3 lbf ft)
Screw, guide rail	M8	15 Nm (11.1 lbf ft) Loctite®243™
Screw, oil/water heat exchanger	M8	15 Nm (11.1 lbf ft) Loctite®243™
Screw, tensioning rail	M8	15 Nm (11.1 lbf ft) Loctite®243™
Stud, exhaust flange	M8	10 Nm (7.4 lbf ft)
Oil pressure sensor	M10x1	15 Nm (11.1 lbf ft)
Plug, clutch lubrication	M10x1	10 Nm (7.4 lbf ft)
Screw plug, cam lever axis	M10x1	12 Nm (8.9 lbf ft)
Screw plug, spreading transmission lock	M10x1	12 Nm (8.9 lbf ft)

Screw, conrod bearing	M10x1	Step 1 25 Nm (18.4 lbf ft) Step 2 30 Nm (22.1 lbf ft) Step 3 90°
Screw, unlocking for timing chain tensioner	M10x1	8 Nm (5.9 lbf ft)
Spark plug	M10x1	11 Nm (8.1 lbf ft)
Coolant temperature sensor	M10x1.25	12 Nm (8.9 lbf ft)
Screw, engine bearer	M10x1.5	45 Nm (33.2 lbf ft)
Cylinder head screw	M11x1.5	Tightening sequence: Using a crisscross pattern Step 1 15 Nm (11.1 lbf ft) Step 2 30 Nm (22.1 lbf ft) Step 3 90° Step 4 90° Lubricated with engine oil
Rotor screw	M12x1.5	115 Nm (84.8 lbf ft)
Spark plug	M12x1.5	18 Nm (13.3 lbf ft)
Nut of engine sprocket	M20x1.5	100 Nm (73.8 lbf ft) Loctite®243™
Oil drain plug	M20x1.5	20 Nm (14.8 lbf ft)
Nut, inner clutch hub	M22x1.5	140 Nm (103.3 lbf ft)
Plug, timing-chain tensioner	M24x1.5	25 Nm (18.4 lbf ft)
Screw plug, alternator cover	M24x1.5	8 Nm (5.9 lbf ft)
Nut, primary gear wheel	M33LHx1.5	130 Nm (95.9 lbf ft) Loctite®243™

23.3 Capacities

23.3.1 Engine oil

Engine oil Ambient temperature: $\geq 0\text{ }^{\circ}\text{C}$ ($\geq 32\text{ }^{\circ}\text{F}$)	3.50 l (3.7 qt.)	Engine oil (SAE 10W/50) ( p. 161)
Engine oil Ambient temperature: $< 0\text{ }^{\circ}\text{C}$ ($< 32\text{ }^{\circ}\text{F}$)		Engine oil (SAE 5W/40) ( p. 162)

23.3.2 Coolant

Coolant	3.20 l (3.38 qt.)	Coolant ( p. 161)
---------	-------------------	---

23.3.3 Fuel

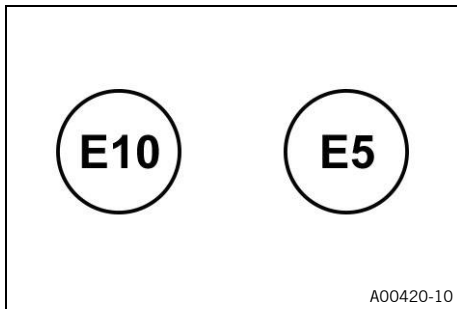

Please observe the labels on EU fuel pumps.

Total fuel tank capacity, approx.	23 l (6.1 US gal)	Super unleaded (ROZ 95) ( p. 162)
Fuel reserve, approx.	3.5 l (3.7 qt.)	

23.4 Chassis

Frame	Lattice frame made of chrome molybdenum steel tubing, powder-coated
Fork	WP Suspension Semi-active Suspension
Shock absorber	WP Suspension Semi-active Suspension
Suspension travel	
front	125 mm (4.92 in)
rear	156 mm (6.14 in)
Brake system	
front	Double disc brake with radially mounted four-piston brake calipers, floating brake discs
rear	Single disc brake with dual-piston brake caliper, fixed brake disc
Brake discs - diameter	
front	320 mm (12.6 in)
rear	240 mm (9.45 in)
Brake discs - wear limit	
front	4.5 mm (0.177 in)
rear	4.5 mm (0.177 in)
Tire pressure, solo / with passenger / full payload	
front: with cold tires	2.7 bar (39 psi)
rear: with cold tires	2.9 bar (42 psi)
Secondary drive ratio	17:38
Chain	5/8 x 5/16" (525) X-ring
Steering head angle	65.1°
Wheelbase	1,482 ± 15 mm (58.35 ± 0.59 in)
Seat height unloaded	835 mm (32.87 in)
Ground clearance unloaded	141 mm (5.55 in)
Weight without fuel approx.	216 kg (476 lb.)
Maximum permissible front axle load	165 kg (364 lb.)
Maximum permissible rear axle load	320 kg (705 lb.)

Maximum permissible overall weight	456 kg (1,005 lb.)
------------------------------------	--------------------

23.5 Electrical system

12-V battery	YTZ14S	Battery voltage: 12 V Nominal capacity: 11.2 Ah Maintenance-free
RACE-ON key battery	CR 2032	3 V
Fuse	58011109110	10 A
Fuse	58011109115	15 A
Fuse	58011109125	25 A
Fuse	58011109130	30 A

Low beam/high beam	LED
Position light	LED
Cornering light	LED
Combination instrument lighting and indicator lamps	LED
Turn signal	LED
Tail light	LED
Brake light	LED
License plate lamp	LED

23.6 Tires

Validity	Front tire	Rear tire
(SUPER DUKE GT EU/JP)	120/70 ZR 17 M/C 58W TL Continental ContiSportAttack 4	190/55 ZR 17 M/C 75W TL Continental ContiSportAttack 4
(SUPER DUKE GT CN)	120/70 ZR 17 M/C 58W TL Pirelli Angel GT	190/55 ZR 17 M/C 75W TL Pirelli Angel GT

The tires specified represent one of the possible series production tires. Additional information is available in the Service section under:
KTM.COM

23.7 Fork

Fork article number	14.18.1Q.23
Fork	WP Suspension Semi-active Suspension
Spring length with preload spacer(s)	335 mm (13.19 in)
Spring rate	
Medium (standard)	20 N/mm (114 lb/in)
Fork length	776 mm (30.55 in)

Fork oil, fork leg, left	670 ml (22.65 fl. oz.)	Fork oil (SAE 4) (48601166S1) (📖 p. 162)
Fork oil, fork leg, right	410 ml (13.86 fl. oz.)	Fork oil (SAE 4) (48601166S1) (📖 p. 162)

23.8 Shock absorber

Shock absorber article number	01.18.1Q.23
Shock absorber	WP SuspensionSemi-active Suspension
Spring rate	
Medium (standard)	185 N/mm (1,056 lb/in)
Spring length	185 mm (7.28 in)
Static sag	24 mm (0.94 in)

23.9 Chassis tightening torques

Nut, socket	Plastic nut	4 Nm (3 lbf ft)
Remaining screws, chassis	EJOT PT® K50x12	1 Nm (0.7 lbf ft)
Remaining screws, chassis	EJOT PT® K50x14	1 Nm (0.7 lbf ft)
Remaining screws, chassis	EJOT PT® K50x16	2 Nm (1.5 lbf ft)
Remaining screws, chassis	EJOT PT® K50x18	2 Nm (1.5 lbf ft)
Remaining screws, chassis	EJOT PT® K45x12	1 Nm (0.7 lbf ft)
Screw, air filter box cover	EJOT PT® K60x30	2 Nm (1.5 lbf ft)
Screw, ball head holder on head-light	EJOT Altracs® 50x12	7 Nm (5.2 lbf ft)
Screw, brake fluid reservoir, rear brake		3.5 Nm (2.58 lbf ft)
Screw, exhaust valve cover fastening	EJOT SF® M4x6-K	4 Nm (3 lbf ft)
Screw, tail light	EJOT PT® K50x14	2.5 Nm (1.84 lbf ft)
Screw, brake fluid reservoir, rear brake	M4	1 Nm (0.7 lbf ft)
Screw, combination switch, left	M4	5 Nm (3.7 lbf ft)
Screw, fixed grip, left	M4	3 Nm (2.2 lbf ft)
Screw, side stand sensor	M4	2 Nm (1.5 lbf ft)
		Loctite®243™
Remaining nuts, chassis	M5	5 Nm (3.7 lbf ft)
Remaining screws, chassis	M5	5 Nm (3.7 lbf ft)
Screw for throttle grip	M5	3.5 Nm (2.58 lbf ft)
Screw, cable channel	M5	5 Nm (3.7 lbf ft)
Screw, chain sliding guard	M5	5 Nm (3.7 lbf ft)
Screw, combination instrument bracket on mask support bottom	M5x45	1.5 Nm (1.11 lbf ft)
Screw, combination instrument bracket on mask support top	M5x12	4 Nm (3 lbf ft)
Screw, combination instrument holder on mask support	M5	4 Nm (3 lbf ft)
Screw, combination instrument holder on speedometer silent block	M5	1 Nm (0.7 lbf ft)
Screw, combination switch, right	M5	5 Nm (3.7 lbf ft)
Screw, cornering light	M5	2 Nm (1.5 lbf ft)
Screw, frame cover in the frame triangle	M5	4.5 Nm (3.32 lbf ft)

Screw, fuel level sensor	M5	3 Nm (2.2 lbf ft)
Screw, fuel tank filler cap	M5	3 Nm (2.2 lbf ft)
Screw, holder for RACE-ON antenna	M5	3 Nm (2.2 lbf ft)
Screw, light control unit holder	M5	3.5 Nm (2.58 lbf ft)
Screw, mask support	M5	4 Nm (3 lbf ft)
Screw, presilencer heat protector	M5	4 Nm (3 lbf ft)
Screw, trim	M5x12	3.5 Nm (2.58 lbf ft)
Swing angle sensor screw	M5x16	6 Nm (4.4 lbf ft) Loctite®243™
Cable disk nut, exhaust valve control unit	M6	14 Nm (10.3 lbf ft)
Ground fitting on frame	M6	10 Nm (7.4 lbf ft)
Lock nut on exhaust valve throttle cable	M6	5 Nm (3.7 lbf ft)
Mushroom head screw for seat and fuel tank spoiler	M6	6 Nm (4.4 lbf ft)
Nut, ABS module fastening	M6	8 Nm (5.9 lbf ft)
Nut, cable on starter motor	M6	6 Nm (4.4 lbf ft)
Nut, exhaust valve control unit throttle cable	M6	5 Nm (3.7 lbf ft)
Remaining nuts, chassis	M6	10 Nm (7.4 lbf ft)
Remaining screws, chassis	M6	10 Nm (7.4 lbf ft)
Screw, 6-D sensor cover	M6	6 Nm (4.4 lbf ft) Loctite®243™
Screw, ABS module fastening	M6	6 Nm (4.4 lbf ft)
Screw, acceleration sensor	M6x16	6 Nm (4.4 lbf ft)
Screw, activated carbon filter holder	M6	6 Nm (4.4 lbf ft)
Screw, ball joint of push rod on foot brake cylinder	M6	5 Nm (3.7 lbf ft) Loctite®243™
Screw, battery terminal	M6	4.5 Nm (3.32 lbf ft)
Screw, cable on starter relay	M6	6 Nm (4.4 lbf ft)
Screw, clutch lever assembly	M6	5 Nm (3.7 lbf ft)
Screw, connecting piece, rear brake line	M6	10 Nm (7.4 lbf ft) Loctite®243™
Screw, cooler retaining bracket	M6	7 Nm (5.2 lbf ft)
Screw, engine sprocket cover	M6	8 Nm (5.9 lbf ft)
Screw, exhaust clamp on main silencer	M6	8 Nm (5.9 lbf ft)
Screw, exhaust clamp on manifold	M6	8 Nm (5.9 lbf ft)
Screw, foot brake cylinder	M6	10 Nm (7.4 lbf ft) Loctite®243™
Screw, front wheel speed sensor	M6	4 Nm (3 lbf ft)
Screw, fuel pump	M6	6 Nm (4.4 lbf ft)
Screw, fuel tap	M6	6 Nm (4.4 lbf ft)
Screw, heat protector for exhaust valve actuator	M6	5 Nm (3.7 lbf ft)

Screw, license plate holder on lower rear panel	M6	12 Nm (8.9 lbf ft)
Screw, passenger seat latch	M6	6 Nm (4.4 lbf ft)
Screw, radiator hose clip	M6	3 Nm (2.2 lbf ft)
Screw, rear wheel speed sensor	M6	4 Nm (3 lbf ft)
Screw, shift lever stub	M6	10 Nm (7.4 lbf ft) Loctite®243™
Screw, shift rod	M6	5 Nm (3.7 lbf ft) Loctite®243™
Screw, shift shaft deflector on shift shaft	M6	18 Nm (13.3 lbf ft) Loctite®243™
Screw, side stand stub	M6	6 Nm (4.4 lbf ft) Loctite®243™
Screw, side stand stub extension	M6	6 Nm (4.4 lbf ft) Loctite®243™
Screw, steering damper bracket on frame	M6	8 Nm (5.9 lbf ft) Loctite®243™
Screw, step plate for foot brake lever	M6	10 Nm (7.4 lbf ft) Loctite®243™
Screw, suitcase molds	M6	6 Nm (4.4 lbf ft)
Screw, tank support on frame front	M6	3.5 Nm (2.58 lbf ft)
Screw, tire pressure sensor (SUPER DUKE GT EU/CN)	M6	7 Nm (5.2 lbf ft)
Screw, voltage regulator	M6	6 Nm (4.4 lbf ft)
Cable disk nut, exhaust valve	M8	7 Nm (5.2 lbf ft)
Nut, manifold on cylinder head	M8	Tightening sequence: Tighten the nuts evenly. Do not warp the metal plate. 25 Nm (18.4 lbf ft)
Nut, rear sprocket	M8	36 Nm (26.6 lbf ft) Loctite®243™
Nut, shift rod	M8	12 Nm (8.9 lbf ft)
Nut, shift rod	M8LH	12 Nm (8.9 lbf ft)
Nut, valve, angled (1290 SUPER DUKE GT JP)	M8	4 Nm (3 lbf ft)
Nut, valve, angled (SUPER DUKE GT EU/CN)	M8	6 Nm (4.4 lbf ft) Loctite®243™
Remaining nuts, chassis	M8	25 Nm (18.4 lbf ft)
Remaining screws, chassis	M8	25 Nm (18.4 lbf ft)
Screw, adapter for ignition lock fastening	M8	15 Nm (11.1 lbf ft) Loctite®243™
Screw, axle clamp	M8	15 Nm (11.1 lbf ft)
Screw, bottom triple clamp	M8	15 Nm (11.1 lbf ft)
Screw, chain securing guide	M8	15 Nm (11.1 lbf ft) Loctite®243™
Screw, foot brake lever	M8	20 Nm (14.8 lbf ft) Loctite®243™
Screw, front brake disc	M8	28 Nm (20.7 lbf ft) Loctite®2701™

Screw, front rider footrest bracket	M8	25 Nm (18.4 lbf ft) Loctite®243™
Screw, hand guard	M8	20 Nm (14.8 lbf ft)
Screw, handlebar clamp	M8	20 Nm (14.8 lbf ft)
Screw, ignition lock (tamper-proof screw)	M8	25 Nm (18.4 lbf ft)
Screw, rear brake caliper	M8	25 Nm (18.4 lbf ft) Loctite®2701™
Screw, rear brake disc	M8	28 Nm (20.7 lbf ft) Loctite®243™
Screw, shift lever on footrest bracket	M8	20 Nm (14.8 lbf ft) Loctite®243™
Screw, shift shaft deflector on frame	M8	10 Nm (7.4 lbf ft) Loctite®243™
Screw, side stand bracket	M8	25 Nm (18.4 lbf ft) Loctite®243™
Screw, side stand spring	M8	15 Nm (11.1 lbf ft) Loctite®2701™
Screw, steering damper on holder	M8	8 Nm (5.9 lbf ft) Loctite®243™
Screw, steering damper on triple clamp	M8	8 Nm (5.9 lbf ft) Loctite®243™
Screw, steering stem clamp	M8	20 Nm (14.8 lbf ft) Loctite®243™
Screw, top triple clamp	M8	18 Nm (13.3 lbf ft)
Remaining nuts, chassis	M10	45 Nm (33.2 lbf ft)
Remaining screws, chassis	M10	45 Nm (33.2 lbf ft)
Screw, brake line restrictor	M10	25 Nm (18.4 lbf ft)
Screw, engine bearer	M10	45 Nm (33.2 lbf ft) Loctite®243™
Screw, front brake caliper	M10	45 Nm (33.2 lbf ft) Loctite®243™
Screw, handlebar support	M10	40 Nm (29.5 lbf ft) Loctite®243™
Screw, side stand	M10	40 Nm (29.5 lbf ft) Loctite®243™
Screw, side stand bracket	M10	45 Nm (33.2 lbf ft) Loctite®243™
Screw, side stand retaining plate	M10	45 Nm (33.2 lbf ft) Loctite®243™
Screw, subframe	M10	45 Nm (33.2 lbf ft)
Banjo bolt, brake line	M10x1	25 Nm (18.4 lbf ft)
Banjo bolt, brake line, connecting piece, rear	M10x1	15 Nm (11.1 lbf ft)
Nut, rear hub shock absorber carrier	M10x1.25	45 Nm (33.2 lbf ft) Loctite®243™
Screw, brake caliper support	M12	28 Nm (20.7 lbf ft)
Lambda sensor	M12x1.25	24.5 Nm (18.07 lbf ft)
Screw, bottom shock absorber	M14x1.5	80 Nm (59 lbf ft) Thread greased

23 TECHNICAL DATA

Screw, top shock absorber	M14x1.5	80 Nm (59 lbf ft) Thread greased
Screw, eccentric	M16	70 Nm (51.6 lbf ft)
Nut, fork pivot	M19x1.5	130 Nm (95.9 lbf ft) Thread greased
Nut, seat lock	M22x1.5	3 Nm (2.2 lbf ft)
Screw, front wheel spindle	M25x1.5	45 Nm (33.2 lbf ft) Thread greased
Screw, steering head, top	M25x1.5	18 Nm (13.3 lbf ft)
Nut, rear axle, shock absorber side	M35x1.5	200 Nm (147.5 lbf ft) Loctite® 2701™ /lock the locking wire with locking varnish
Nut, rear axle	M50x1.5	250 Nm (184.4 lbf ft) Thread greased/lock locking wire with locking varnish

24.1 Declarations of conformity



Info

The functional and equipment scope is model-dependent and may not include all wireless systems and application areas referred to.

KTM AG hereby declares that the **KTM RACE ON system** wireless system conforms with the relevant guidelines. The full text of the Declaration of Conformity is available at the following Internet address.

Certification website: <http://www.ktm.com/ktm-race-on-system>

Polaris hereby declares that the **Connectivity Control Unit "CCU-2"** wireless system conforms with the relevant guidelines. The full text of the Declaration of Conformity is available at the following Internet address.

Certification website: <http://www.ktm.com/ccu-2>

Schrader Electronics Ltd hereby declares that the **Tyre Pressure Monitoring System** wireless system conforms with the relevant guidelines. The full text of the Declaration of Conformity is available at the following Internet address.

Certification website: <http://www.ktm.com/tpms>

24.2 Country-specific declarations of conformity

KTM RACE ON system

Advertencias de IFETEL
La operación de este equipo está sujeta a las siguientes dos condiciones:
(1) es posible que este equipo o dispositivo no cause interferencia perjudicial y
(2) este equipo o dispositivo debe aceptar cualquier interferencia, incluyendo la que pueda causar su operación no deseada.
Modelo XCB0307 (unidad central) K0349-0 (llave activa)
Certificado Homologacion Numero: **RLVZAXC17-1560**

R 001 – A10834

CNC COMISIÓN NACIONAL DE COMUNICACIONES
H-20232

MCMC
HIDF17000192

Model: K0349-0

06880-17-08714

"Este equipamento opera em caráter secundário, isto é, não tem direito a proteção contra interferência prejudicial, mesmo de estações do mesmo tipo, e não pode causar interferência a sistemas operando em caráter primário."

Model: XCB0307

07025-17-08714

"Este equipamento opera em caráter secundário, isto é, não tem direito a proteção contra interferência prejudicial, mesmo de estações do mesmo tipo, e não pode causar interferência a sistemas operando em caráter primário."

ICASA TA-2017/1410

NOTICE

This equipment has been registered with the Telecommunications Regulatory Authority for use in the UAE.

TRA REGISTERED No: ER63530/18
DEALER No: DA75721/18

NOTICE

This equipment has been registered with the Telecommunications Regulatory Authority for use in the UAE.

TRA REGISTERED No: ER63531/18
DEALER No: DA75721/18

AGREE PAR L'ANRT MAROC
Numéro d'agrément : MR 14688 ANRT 2017
Date d'agrément : 31/08/2017

AGREE PAR L'ANRT MAROC
Numéro d'agrément : MR 14690 ANRT 2017
Date d'agrément : 31/08/2017

מודע זה מכשיר מורישיון הפעלה אלווויסי. המודע אסור לשימוש למתן שירות לבד ג'. אסור להחליף אנטנת המכשיר המקוריית. אסור לעשות במכשיר כל שינוי מבני.

This product does not need an Israeli wireless operation license. It is forbidden to use this product for service to third party. It is forbidden to replace the original antenna. It is forbidden to make any technical change in this product.

UA.TR.109.0200-17

UA.TR.109.0198-17

Company name: ZADI S.p.A.
Equipment Name: Keyless System
Basic Model Name: XCB0305
Series Model Name: XCB0307
Manufactured Date: Week / Year
Manufacturer / Country: ZADI S.p.A./ ITALY

R-RRM-ZAD-XCB0305

Company name: ZADI S.p.A.
Equipment Name: RRS Remote control key
Model Name: K0349-0
Manufactured Date: Week / Year
Manufacturer / Country: ZADI S.p.A./ ITALY

R-CRM-ZAD-K0349-0

Complies with
IMDA Standards
DA107682

S03192-01

24.3 Country-specific declarations of conformity (CCU-2)

 CONTAINS FCC ID: 2A0W7-K001 CONTAINS IC: 5966A-K001 CMIIT ID: XXXXXXXXX	 TRAIL TECH Polaris Industries Inc. Connectivity Control Unit Model: CCU-2 Country of Origin: USA Input: 14VDC 1.1A	 
 04624-20-12908	 R-C-1PR-CCU	 R-NZ
 CCAJ20LP09A0T1 ID: C-24749	 R-209-J00406	 NOM Polaris Industries Unidad de control de comunicaciones Trail Tech CCU-2 INPUT: 14Vcc 1.1A USA
 UA.032.CT.0103-20	IFT #: RCPTRCC20-0716	 TP BY
AGREE PAR L'ANRT MAROC Numéro d'agrément: MR22163 ANRT 2020 Date d'agrément: 25/02/2020	 MCMC RFCP/17A/0520/S(20-1955)	Complies with IMDA Standards DA107035
 nabp. เครื่องวิทยุคมนาคมนี้ ได้รับยกเว้น ไม่ต้องได้ รับใบอนุญาตให้มี ใช้ซึ่งเครื่องวิทยุคมนาคม หรือตั้งสถานีวิทยุคมนาคมตามประกาศ กสทช. เรื่อง เครื่องวิทยุคมนาคม และสถานีวิทยุ คมนาคมที่ได้รับยกเว้นไม่ต้องได้รับใบอนุญาต วิทยุคมนาคมตามพระราชบัญญัติวิทยุคมนาคม พ.ศ. 2498		TRA REGISTERED No: ER79816/20 DEALER No: DA68241/17
 nabp. โทรคมนาคม กำกับดูแลเพื่อประชาชน Call Center 1200 (InSW5)		 TA-2020/5195 APPROVED Certified for use in Hong Kong 經認證可在香港使用 Certificate No. 證書號碼 HK0012002210  香港通訊事務管理局 COMMUNICATIONS AUTHORITY

E02299-01

Brake fluid DOT 4 / DOT 5.1**Standard/classification**

- DOT

Guideline

- Use only brake fluid that complies with the specified standard (see specifications on the container) and that exhibits the corresponding properties.

Recommended supplier**Castrol**

- **REACT PERFORMANCE DOT 4**

MOTOREX®

- **Brake Fluid DOT 5.1**

Coolant**Guideline**

- Only use high-grade, silicate-free coolant with corrosion inhibitor additive for aluminum motors. Low grade and unsuitable antifreeze causes corrosion, deposits and frothing.
- Do not use pure water as only coolant is able to meet the requirements needed in terms of corrosion protection and lubrication properties.
- Only use coolant that complies with the requirements stated (see specifications on the container) and that has the relevant properties.

Antifreeze protection to at least	-25 °C (-13 °F)
-----------------------------------	-----------------

The mixture ratio must be adjusted to the necessary antifreeze protection. Use distilled water if the coolant needs to be diluted.

The use of premixed coolant is recommended.

Observe the coolant manufacturer specifications for antifreeze protection, dilution and miscibility (compatibility) with other coolants.

Recommended supplier**MOTOREX®**

- **COOLANT M3.0**

Engine oil (SAE 10W/50)**Standard/classification**

- JASO T903 MA2 (📖 p. 164)
- SAE (📖 p. 164) (SAE 10W/50)

Guideline

- Use only engine oils that comply with the specified standards (see specifications on the container) and that possess the corresponding properties.

Fully synthetic engine oil

Recommended supplier**MOTOREX®**

- **Power Synt 4T**

Engine oil (SAE 5W/40)

Standard/classification

- JASO T903 MA2 (📖 p. 164)
- SAE (📖 p. 164) (SAE 5W/40)

Guideline

- Use only engine oils that comply with the specified standards (see specifications on the container) and that possess the corresponding properties.

Fully synthetic engine oil

Recommended supplier

MOTOREX®

- Power Synt 4T

Fork oil (SAE 4) (48601166S1)

Standard/classification

- SAE (📖 p. 164) (SAE 4)

Guideline

- Use only oils that comply with the specified standards (see specifications on the container) and that exhibit the corresponding properties.

Super unleaded (ROZ 95)

Standard/classification

- DIN EN 228 (ROZ 95)

Guideline

- Only use super unleaded fuel that matches or is equivalent to the specified standard.
- Fuel with an ethanol content of up to 10% (E10 fuel) is safe to use.



Info

Do **not** use fuel containing methanol (e.g., M15, M85, M100) or more than 10% ethanol (e.g., E15, E25, E85, E100).

Chain cleaner

Recommended supplier
MOTOREX®
– Chain Clean

Fuel additive

Recommended supplier
MOTOREX®
– Fuel Stabilizer

Long-life grease

Recommended supplier
MOTOREX®
– Bike Grease 2000

Motorcycle cleaner

Recommended supplier
MOTOREX®
– Moto Clean

Perfect finish and high gloss polish for paints

Recommended supplier
MOTOREX®
– Moto Shine

Preserving materials for paints, metal and rubber

Recommended supplier
MOTOREX®
– Moto Protect

Special cleaner for glossy and matte paint finishes, metal and plastic surfaces

Recommended supplier
MOTOREX®
– Quick Cleaner

Street chain spray

Guideline
Recommended supplier
MOTOREX®
– Chainlube Road Strong

Universal oil spray

Recommended supplier
MOTOREX®
– Joker 440 Synthetic

JASO T903 MA2

Different technical development directions required a separate specification for motorcycles – the **JASO T903 MA2** standard.

Earlier, engine oils from the automobile industry were used for motorcycles because there was no separate motorcycle specification.

Whereas long service intervals are demanded for automobile engines, the focus for motorcycle engines is on high performance at high engine speeds.

In most motorcycle engines, the transmission and clutch are lubricated with the same oil.

The **JASO T903 MA2** standard meets these special requirements.

SAE

The SAE viscosity classes were defined by the Society of Automotive Engineers and are used for classifying oils according to their viscosity. The viscosity describes only one property of oil and says nothing about quality.

ABS	Anti-lock braking system	Safety system that prevents locking of the wheels when driving straight ahead without the influence of lateral forces
ATIR	Automatic Turn Indicator Reset	Software, which automatically switches the indicator off according to a time or travel distance counter
BTM	Brake Temperature Monitoring	System which calculates the temperature of the brake system and informs the rider of overheating
ETTC	Engine traction torque control	Auxiliary function of the engine control, which prevents rear wheel locking with excessive engine braking effect, by lightly opening the throttle valve
HHC	Hill Hold Control	Assist, which prevents the vehicle from rolling backwards on an incline
-	KTM RACE ON	System that releases the ignition, steering lock, and fuel tank filler cap via a remote key with a transponder
-	Launch control	Vehicles electronics functions for achieving the best possible acceleration from a standing position
MSC	Motorcycle stability control	This is an auxiliary function for the ABS, which can prevent locking and slipping of the wheels during braking while leaning at an angle, within physical limitations
MTC	Motorcycle Traction Control	Auxiliary function of the motor control that reduces engine torque with spinning rear wheel
OBD	On-board diagnosis	Vehicle system, which monitors the specified parameters of the vehicle electronics
-	Quickshifter +	Engine electronics function for shifting up and down without clutch actuation

29 LIST OF ABBREVIATIONS

Art. no.	Article number
ca.	circa
cf.	compare
e.g.	for example
etc.	et cetera
i.a.	inter alia
no.	number
poss.	possibly







30.1 Red symbols

Red symbols indicate an error condition that requires immediate intervention.

	The oil pressure warning lamp lights up red – The oil pressure is too low. Stop immediately, taking care not to endanger yourself or other road users in the process, and switch off the engine.
---	--





30.2 Yellow and orange symbols

Yellow and orange symbols indicate an error condition that requires prompt intervention. Active driving aids are also represented by yellow or orange symbols.

	RACE-ON indicator lamp lights up/flashes yellow/orange/red – Status or error messages relating to Race-on system/alarm system.
	The general warning lamp lights up yellow – A note/warning note on operating safety has been detected. This is also shown in the display.
	The malfunction indicator lamp lights up yellow – The OBD has detected a malfunction in the vehicle electronics.
	TC indicator lamp lights up/flashes yellow – The MTC (p. 134) is not enabled or is currently intervening. The TC indicator lamp also lights up if a malfunction is detected. Contact an authorized KTM workshop. The TC indicator lamp flashes if the motorcycle traction control actively engages or if the HHC (p. 78) (optional) is activated.
	The cruise control system indicator lamp lights up yellow – The cruise control system function is switched on, but cruise control is not activated.
	The ABS warning lamp lights up yellow – Status or error messages relating to ABS. The ABS warning lamp flashes if the ABS mode Supermoto is enabled.
	Ice warning is active in the display – The warning lamp lights up when there is increased risk of icy roads.

30.3 Green and blue symbols

Green and blue symbols reflect information.

	The left turn signal indicator lamp flashes green with a steady rhythm – The left turn signal is switched on.
	The cruise control system indicator lamp lights up green – The cruise control system function is switched on and cruise control is activated.
	The high beam indicator lamp lights up blue – The high beam is switched on.
	The right turn signal indicator lamp flashes green with a steady rhythmic flash – The right turn signal is switched on.
	The idle indicator lamp lights up green – The transmission is in the neutral position.

+	
+RES/-SET button	
operation	19
1	
12-V battery	
charging	121
installing	120
removing	119
A	
ABS	103
ACC1	
front	131
rear	131
ACC2	
front	131
rear	131
Anti wheelie mode	78
Anti-lock braking system	103
Applying the brakes	82
Auxiliary substances	11
B	
Brake discs	
checking	105
Brake fluid	
front brake, adding	106
of rear brake, adding	108
Brake fluid level	
front brake, checking	105
rear brake, checking	108
Brake linings	
front brake, checking	107
rear brake, checking	109
Brake system	103-110
temperature monitoring, rear	104
Brakes	82
Breakdown	
towing	85
C	
C1 and C2 switch	21
Capacity	
Coolant	151
engine oil	138, 151
fuel	86, 152
Case holders	27
Chain	
checking	97
cleaning	95
dirt, checking for	94
Chain guide	
checking	97
Chain tension	
adjusting	96
checking	95
Clutch	
fluid level, checking/correcting	99
Clutch lever	16
basic position, adjusting	68
Combination instrument	29-65
ABS	44
ABS display	37
activation and test	30
Anti Wheelie Mode (optional)	46
Audio	52
Bike Info	41
Bluetooth	56
brake system, temperature warning	31
Button Illumination	54
C1 and C2 buttons	53
Call display	40
Clock & Date	60
Clock Format	61
coolant temperature indicator	38
Cornering Light Test	60
cruise control indicator	36
Custom Switch	53
Damping	47, 89
Damping display	37
Date Format	61
display	33
DRL	55
engine speed	36
Extra Functions	64
Favorites	49, 54
Favorites display	40
Favorites indicator 1-4	54
fuel level display	39
gear display	38
Headset Type	58
heated grip (optional)	39
Heating (optional)	51
Heating Grips (optional)	51
Heating Rider Seat (optional)	52
Hill Hold Control (optional)	58
ice warning	31
indicator lamps	32
KTMconnect	55
Language	62
Last search	48
Launch Control (optional)	47

- Load** 48, 89
- Load display** 38
- menu 41
- Motorcycle** 43
- MTC** 44
- MTC display** 37
- MTC+MSR (optional)** 45
- navigation 48
- Navigation display** 40
- overview 29
- Performance Display (optional) 35
- Phone** 56
- Quickshifter + (optional)** 58
- Ride Mode** 43, 134
- Ride-Mode display** 38
- Rider's Headset** 57
- seat heating (optional) 39
- Settings** 53
- Settings Heating** 63
- Settings Heating Grips** 63
- Settings Heating Pillion Seat** 63
- Settings Heating Rider Seat** 63
- shift warning light 36
- Shift Light RPM1** 59
- Shift Light RPM2** 60
- Shift Light State** 59
- Skip Waypoint 50
- slip adjustment 135
- Slip Adjuster (optional)** 46
- speedometer 37
- Stop Navigation 51
- Suspension** 47
- Throttle Response** 135
- Throttle Response (optional)** 45
- Track Display (optional) 34
- Trip** 42
- Trip 1** 42
- Trip 2** 42
- Units** 61
- Units Consumption** 62
- Units Distance** 61
- Units Pressure** 62
- Units Temperature** 62
- volume 50
- warnings 30
- Combination switch**
 - overview left side 16
- Coolant level**
 - checking in the compensating tank 132
 - correcting in the compensating tank 132
- Cornering light** 119
 - range, adjusting 129
 - setting, checking 127
- Cornering MTC** 134
- Cruise control system**
 - operation 18
- Customer service** 11
- D**
- Date**
 - adjusting 64
- Declarations of conformity** 159-160
 - country-specific 159
 - country-specific (CCU-2) 160
- Diagnostics connector** 131
- Driving** 79
- E**
- Emergency OFF switch** 20
- Engine**
 - running in 73
- Engine number** 15
- Engine oil**
 - adding 139
 - changing 136
- Engine oil level**
 - checking 136
- Engine sprocket**
 - checking 97
- Engine traction torque control** 82
- Environment** 9
- F**
- Figures** 11
- Foot brake lever** 28
 - basic position, adjusting 69
 - Setting the step plate 70
- Fork** 89
- Fork legs**
 - dust boots, cleaning 102
- Fork part number** 15
- Front fender**
 - installing 101
 - removing 101
- Front rider's seat**
 - mounting 92
 - removing 92
- Front wheel**
 - installing 112
 - removing 111
- Fuel tank filler cap**
 - closing 26
 - opening 25

Fuel tank spoiler	
installing	101
removing	100
Fuel, oils, etc.	11
Fuses	
in fuse box, changing	126
G	
Grab handle	27
H	
Hand brake lever	16
basic position, adjusting	69
Handlebar position	66
adjusting	66
Hazard warning flasher	20
Hazard warning flasher switch	20
Headlight	
daytime running light	118
high beam	118
low beam	118
range, adjusting	129
setting, checking	127
Horn button	18
I	
Ice warning	31
Immobilizer	22
Implied warranty	11
Indicator lamps	32
Intended use	7
K	
Key number	14
L	
Launch control	77
Light switch	17
Luggage	73
M	
Main fuse	
changing	125
Main silencer	
installing	94
removing	93
Manufacturer warranty	11
Misuse	7
Motorcycle	
cleaning	141
lifting with front lifting gear	90
raising with the rear lifting gear	90
removing the rear from the lifting gear	90
taking off front lifting gear	91
Motorcycle traction control	134
MSR	82
O	
Oil filter	
changing	136
Oil screens	
cleaning	136
Owner's Manual	9
P	
Parking	83
Passenger foot pegs	27
Passenger seat	
mounting	91
removing	91
Preparing for use	
advice on preparing for first use	72
after storage	145
checks and maintenance measures when preparing for use	75
Protective clothing	9
Q	
Quickshifter +	79
R	
RACE-ON button	21
RACE-ON key	21
RACE-ON key battery, changing	124
Rear sprocket	
checking	97
Rear wheel	
installing	114
removing	113
Refueling	
fuel	85
Riding	
starting off	77
starting off with HHC	78
starting off with launch control	77
S	
Safe operation	8
Seat lock	26
Service	11
Service schedule	87-88
Shift lever	28
basic position, adjusting	70
basic position, checking	70
Shift lever stub	
setting	71

Shifting	79
Shock absorber	89
Shock absorber article number	15
Side stand	28
Slip adjustment	135
Socket for electrical accessories	22, 119
Spare parts	11
Start button	20
Starting	75
Steering angle	
adjusting	67
Steering damper article number	15
Steering lock	22
Stopping	83
Storage	144
Storage compartment	
left, closing	25
left, opening	24
right, closing	25
right, opening	24
USB socket	23
Suspension setting	89
T	
Technical accessories	11
Technical data	
capacities	151
chassis	152
chassis tightening torques	154
electrical system	153
engine tightening torques	149
fork	153
shock absorber	154
tires	153
Throttle grip	16
Time	
adjusting	64
Tire condition	
checking	115
Tire pressure	
checking	116
Tire repair spray	
using	116
Tool set	27
Towing	85
Transporting	84
Troubleshooting	146-147
Turn signal switch	17
Type label	14
U	
USB cable	
disconnecting	23
USB cable, connecting	23
USB socket	23
Use definition	7
V	
Vehicle	
loading	73
Vehicle identification number	14
View of vehicle	
front left	12
rear right	13
W	
Windshield	
adjusting	68
installing	93
removing	92
Winter operation	
checks and maintenance steps	142
Work rules	9



3214550en

12/2021

