

## 1290 SUPER ADVENTURE S

ART. NO. 3214614EN





Perform the work described in these setup instructions before the vehicle is delivered to the customer.

Read the setup instructions in their entirety before beginning work.

These setup instructions were written to correspond to the latest state of this series. We reserve the right to make modifications in the interest of technical advancement without at the same time updating these setup instructions.

We shall not provide a description of general workshop methods. Likewise, safety rules that apply in a workshop are not specified here. It is assumed that the work will be performed by a fully trained mechanic.

All specifications contained herein are non-binding. KTM Sportmotorcycle GmbH specifically reserves the right to modify or delete technical specifications, prices, colors, forms, materials, services, designs, equipment, etc., without prior notice and without specifying reasons, to adapt these to local conditions, as well as to stop production of a particular model without prior notice. KTM accepts no liability for delivery options, deviations from figures and descriptions, misprints, and other errors. The models portrayed partly contain special equipment that does not belong to the regular scope of supply.

© 2022 KTM Sportmotorcycle GmbH, Mattighofen Austria

All rights reserved

Reproduction, even in part, as well as copying of all kinds, is permitted only with the express written permission of the copyright owner.



ISO 9001(12 100 6061)

KTM applies quality assurance processes that lead to the highest possible product quality as defined in the ISO 9001 international quality management standard.

Issued by: TÜV Management Service

REG.NO. 12 100 6061

KTM Sportmotorcycle GmbH  
Stallhofnerstraße 3  
5230 Mattighofen, Austria

This document is valid for the following models:

1290 SUPER ADVENTURE S EU (F9903V4, F9903V5)

1290 SUPER ADVENTURE S JP (F9986V4)

1290 SUPER ADVENTURE S US (F9975V4, F9975V5)

1290 SUPER ADVENTURE S CN (F9987V4, F9987V5)



3214614en

01/2022

# 1 MEANS OF REPRESENTATION

## 1.1 Symbols used

The meaning of specific symbols is described below.



Indicates an expected reaction (e.g. of a work step or a function).



Indicates an unexpected reaction (e.g. of a work step or a function).



Indicates a page reference (more information is provided on the specified page).



Indicates information with more details or tips.



Indicates the result of a testing step.



Indicates a voltage measurement.



Indicates a current measurement.



Indicates a resistance measurement.



Indicates the end of an activity including potential rework.

## 1.2 Formats used

The typographical formats used in this document are explained below.

**Proprietary name**

Indicates a proprietary name.

**Name®**

Indicates a protected name.

**Brand™**

Indicates a brand available on the open market.

**Underlined terms**

Refer to technical details of the vehicle or indicate technical terms, which are explained in the glossary.

## 2.1 Transport mode

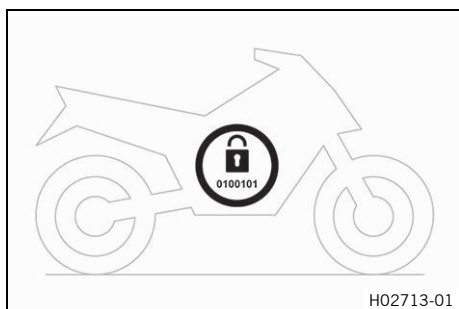

This vehicle was blocked for transport in the software. To operate the vehicle, the vehicle electronics must be enabled. This process is conducted during initial setup in KTM Dealer.net. Enabling ensures that the initial setup in KTM Dealer.net is documented. Enabling can be performed either temporarily, e.g. for a test ride, or permanently for vehicle handover.

**i Info**  
Make sure that the vehicle is permanently enabled before handing it over to the customer.

## 2.2 Diagnostics connector

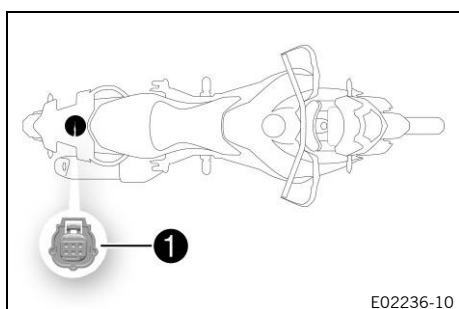

The diagnostics connector **1** is at the rear part of the vehicle.

## 2.3 Unpacking and setting up the vehicle

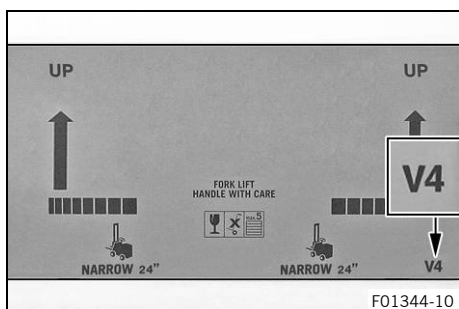

- Remove the straps and the box.



- Remove the adhesive tape in the upper area of the motorcycle.



E02427-01

- Roll down the film at the sides.



**Info**

To avoid damaging the motorcycle during unpacking, leave the other films on the vehicle until you have finished work on the vehicle.

- Remove the separate enclosure and unpack it. Check that the scope of supply is complete using the enclosed packing list.



**Info**

The procedure for missing components is described in the Customer Service Manual.

- Check the vehicle for transport damage.



**Info**

The procedure in the event of transport damage is described in the Customer Service Manual.



E02428-01

- Remove the handbrake pump from the transport holder.
- Remove the screws and handlebar clamps.
- Take off the transport holder.

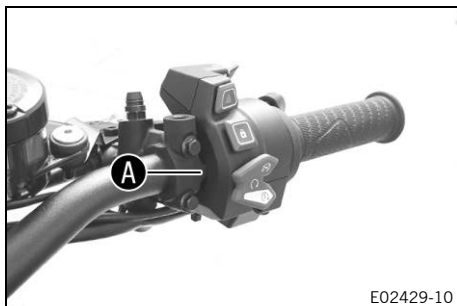

E02429-10

- Position the handbrake pump. Tighten the screws.

Guideline

Anti-rotation lock **A** engages in the right switch unit.

Screw, brake assembly	M6	5 Nm (3.7 lbf ft)
-----------------------	----	-------------------

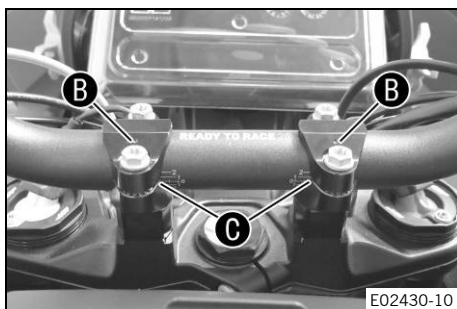

E02430-10

- Position the handlebar.



**Warning**

**Danger of accidents** A repaired handlebar poses a safety risk.

If the handlebar is bent or straightened, the material becomes fatigued. The handlebar may break as a result.

- Change the handlebar if the handlebar is damaged or bent.

**i Info**  
Make sure the cables and wiring are positioned correctly.

- Position the handlebar clamps. Tighten the screws evenly.  
Guideline

Screw, handlebar clamp	M8x25	20 Nm (14.8 lbf ft)
------------------------	-------	---------------------

- ✓ Markings **B** face backward.
- ✓ Handlebar scale markings **C** are located centrally between the handlebar clamps.
- Check the throttle grip for smooth operation.
- Position the cable for the right-hand controls and secure with cable ties.
- Attach the clutch line to the holder.

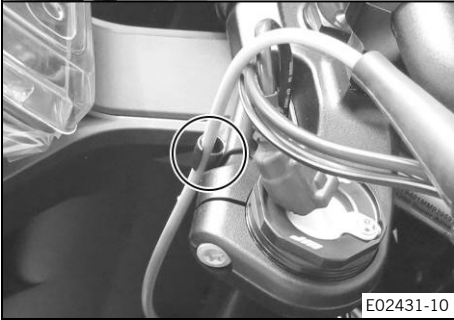

E02431-10

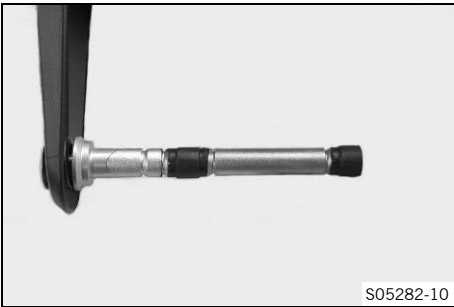

S05282-10

- Preassemble the hand guards with screws and bushings.



- Position the right hand guard.
- Mount and tighten the rear mirror.
- Tighten screw ①.

Guideline

Screw, handle bar end hand guard	M8x40	25 Nm (18.4 lbf ft)
----------------------------------	-------	---------------------



- Repeat these steps on the opposite side.
- Carefully loosen and remove the tension belt from the rear wheel spindle.

Guideline

An assistant prevents the motorcycle from falling over.

- Carefully loosen and remove the tension belts around the lower triple clamp.
- ✓ The vehicle is released at the front.
- Together with an assistant, take the vehicle off the pallet.

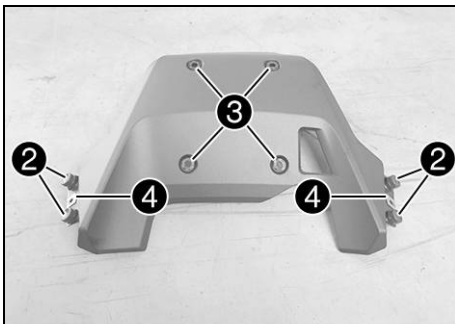

- Mount damping rubbers ②, rubber grommets ③ and speed nuts ④ on the engine guard.

- Mount spacers ⑤.

Guideline

The spacer collar is facing inward.

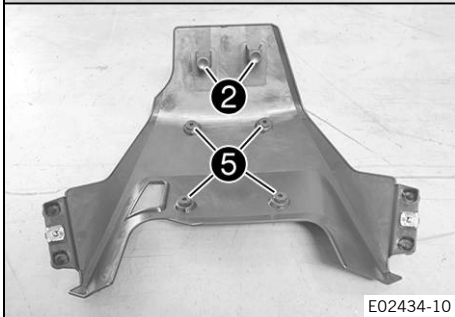

- Mount rubber grommets ⑥ and spacers on lower fuel tank cover.

Guideline

The spacer collar is facing inward.

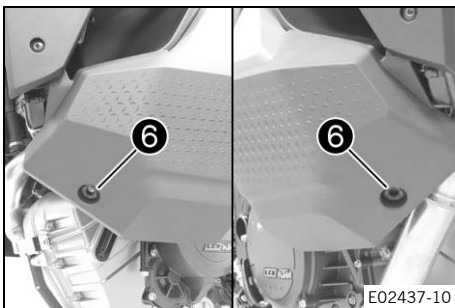



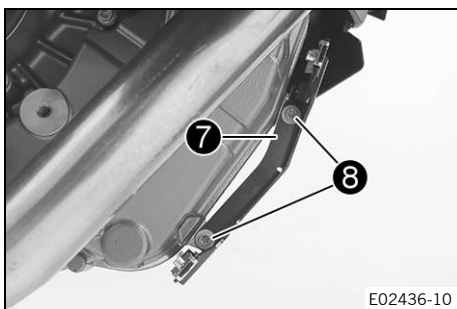

- Position holder **7**.

Guideline

The ridge is facing outwards.

- Mount and tighten screws **8**.

Guideline

Remaining engine screws	M6	10 Nm (7.4 lbf ft)
-------------------------	----	--------------------

- Install the engine guard. (📖 p. 8)

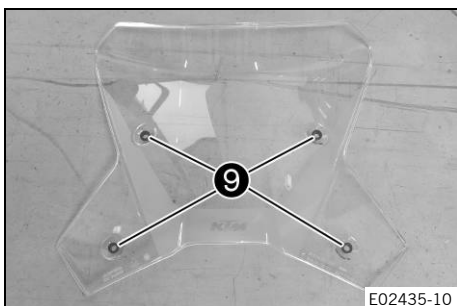

- Mount rubber grommets **9** on the windshield.
- Install the windshield. (📖 p. 8)
- Remove the RACE ON key and the RACE ON chip from the storage compartment and keep in a safe place for the handover.

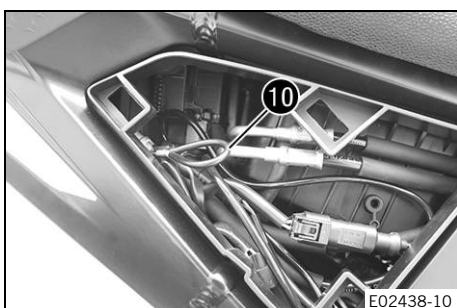

- Remove the rear right side cover. (📖 p. 8)
- Pull catch **10** on the seat release.
- ✓ The seat is unlocked.
- Install the rear right side cover. (📖 p. 8)
- Charge the 12-V battery. (📖 p. 10)

Guideline

The 12-V battery must be fully charged before it is handed over to the customer.



### Info

The first charging process may take longer with a new 12-V battery.

- Remove the remaining film, padding, the corrugated cardboard, and the other packaging material.
- Unpack and mount the **KTM PowerParts** included in the delivery (optional).



### Info

Read the accompanying **KTM PowerParts** fitting instructions.

- Attach the stickers included in the scope of supply (optional).
- Check the headlight setting. (📖 p. 16)
- Turn the knurled screws on both fuel petcocks counterclockwise as far as possible.
- Refuel. (📖 p. 20)
- Prepare the vehicle according to the specifications in **KTM Dealer.net** for handover to the customer.



## 3.1 Installing the windshield

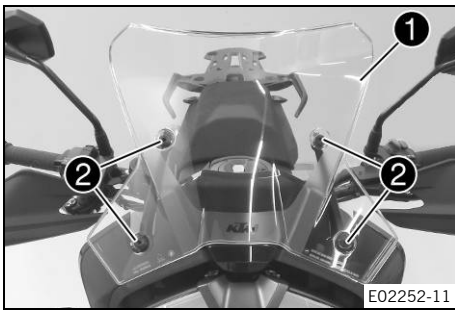

- Position windshield **1**.
- Mount and tighten screws **2** with the rubber bushings.

Guideline

Screw, windshield	M5x14	3.5 Nm (2.58 lbf ft)
-------------------	-------	-------------------------

## 3.2 Removing the rear right side cover



- Take off cover **1** in area **A** and **B**.
- Take off the cover.

## 3.3 Installing the rear right side cover

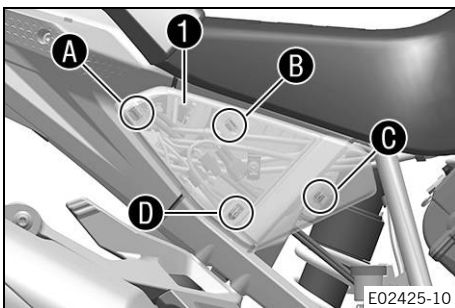

- Position cover **1** and attach it in areas **A**, **B**, **C** and **D**.
- ✓ The cover engages with an audible click.

## 3.4 Installing the engine guard

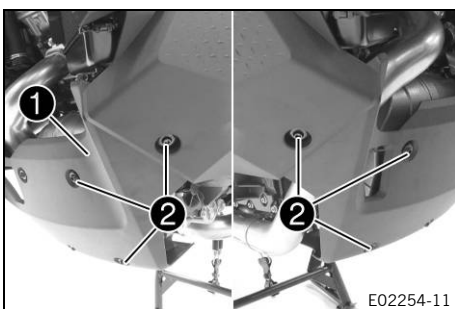

- Position engine guard **1**, mount screws **2** with bushings and tighten.

Guideline

Screw, engine guard	M6	10 Nm (7.4 lbf ft)
---------------------	----	--------------------

## 3.5 Removing the passenger seat

### Condition

The motorcycle is stationary.

The engine is off.

The ignition has been switched on or off for less than 1 minute.

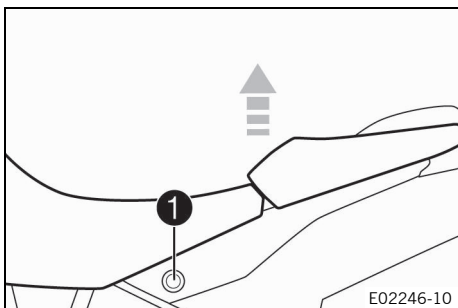

- Press seat release button ①.
- Raise the front of the passenger seat, pull it toward the fuel tank and take off from above.

## 3.6 Mounting the passenger seat

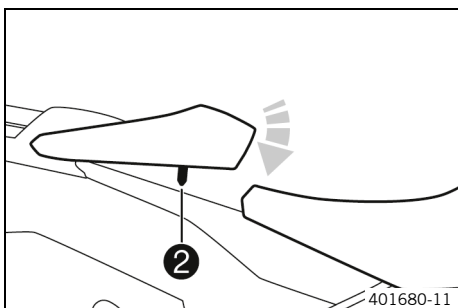

- Attach the hooks on the passenger seat ① to the hanger on the subframe.



### Info

Ensure that the seat heating cable is correctly routed.

- Lower the front of the passenger seat and push it toward the rear at the same time.
- Position locking pin ② in the lock housing and press the passenger seat forward until the locking pin engages with an audible click.
- Check that the passenger seat is mounted correctly.

## 3.7 Removing the front rider's seat

### Preparatory work

- Remove the passenger seat. (📖 p. 9)

### Main work

- Lift the rider's seat back and unhook in the A area.

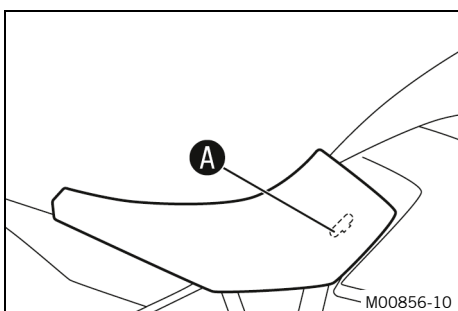

### 3.8 Mounting the front rider's seat

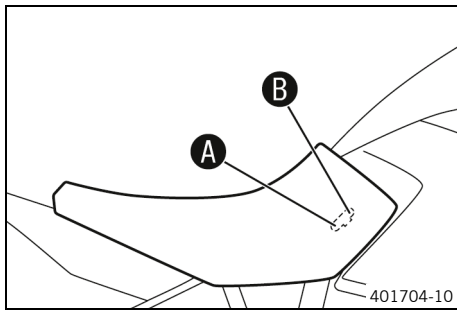

#### Main work

- Attach the recesses on the front rider's seat to the fuel tank at the desired seat position **A** or **B**, and push the front rider's seat forward while lowering it at the rear.
- Finally, check that the front rider's seat is correctly mounted.

#### Finishing work

- Mount the passenger seat. (📖 p. 9)

### 3.9 Charging the 12-V battery



#### Warning

**Risk of injury** Battery acid and battery gases cause serious chemical burns.

- Keep 12 V batteries out of the reach of children.
- Wear suitable protective clothing and safety glasses.
- Avoid contact with battery acid and battery gases.
- Keep sparks or open flames away from the 12 V battery.
- Only charge 12 V batteries in well-ventilated rooms.
- Rinse the affected area immediately with plenty of water in the event of contact with the skin.
- Rinse eyes with water for at least 15 minutes and consult a doctor immediately if battery acid and battery gases get into the eyes.

#### Note

**Danger of damage** An incorrectly selected charging mode will damage the 12-V battery.

- Always select a charging mode that is compatible with the type of battery.



#### Note

**Environmental hazard** 12 V batteries contain environmentally hazardous materials.

- Do not dispose of 12 V batteries as household waste.
- Dispose of 12 V batteries at a collection point for used batteries.



#### Note

**Environmental hazard** Hazardous substances cause environmental damage.

- Dispose of oils, grease, filters, fuel, cleaning agents, brake fluid, etc., correctly and in compliance with the applicable regulations.

**i** **Info**

Even when there is no load on the 12-V battery, it discharges steadily each day. The charging level and the method of charging are very important for the service life of the 12-V battery. Rapid recharging with a high charging current shortens the service life of the battery. If the charging current, charging voltage, and charging time are exceeded, the 12-V battery will be destroyed. If the 12-V battery is depleted from starting the vehicle repeatedly, the battery must be charged immediately. If the 12-V battery is left in a discharged state for an extended period, it will become deeply discharged and sulfating occurs, destroying the battery. The 12-V battery is maintenance-free, i.e. the acid level does not have to be checked.

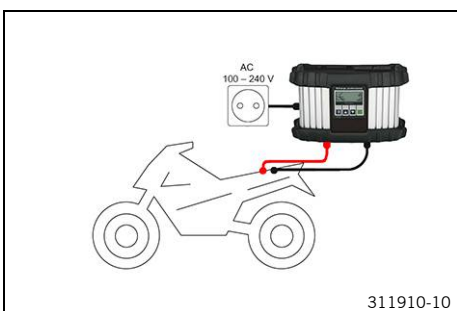

**Preparatory work**

- Remove the passenger seat. (📖 p. 9)
- Remove the front rider's seat. (📖 p. 9)
- Disconnect the negative cable of the 12-V battery. (📖 p. 14)

**Main work**

- Connect a battery charger to the 12-V battery. Adjust the battery charger.

EU battery charger **XCharge-professional** (00029095050)

**Alternative 1**

US battery charger **XCharge-professional** (00029095051)

**Alternative 2**

UK battery charger **XCharge-professional** (00029095052)

**i** **Info**

Follow the instructions of the charger and the manual.

- Disconnect the battery charger after charging the 12-V battery.

**Guideline**

The charging current, charging voltage, and charging time must not be exceeded.	
Recharge the 12-V battery regularly when the motorcycle is not being used	3 months

**Finishing work**

- Connect the negative cable of the 12-V battery. (📖 p. 14)
- Mount the front rider's seat. (📖 p. 10)
- Mount the passenger seat. (📖 p. 9)
- Set time and date.

## 3.10 Removing the 12 V battery

**Warning**

**Risk of injury** Battery acid and battery gases cause serious chemical burns.

- Keep 12 V batteries out of the reach of children.
- Wear suitable protective clothing and safety glasses.
- Avoid contact with battery acid and battery gases.
- Keep sparks or open flames away from the 12 V battery.
- Only charge 12 V batteries in well-ventilated rooms.
- Rinse the affected area immediately with plenty of water in the event of contact with the skin.
- Rinse eyes with water for at least 15 minutes and consult a doctor immediately if battery acid and battery gases get into the eyes.

**Caution**

**Danger of accidents** Electronic components and safety devices will be damaged if the 12-V battery is discharged or missing.

If the 12-V battery is discharged or defective, malfunctions in the vehicle electronics can occur, especially when starting.

- Never operate the vehicle with a discharged 12-V battery or without a 12-V battery.

**Preparatory work**

- Remove the passenger seat. (📖 p. 9)
- Remove the front rider's seat. (📖 p. 9)

**Main work**

- Detach battery retainer rubber ①.
- Remove positive terminal cover ②.

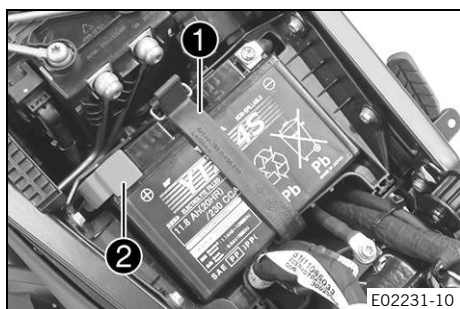

- Disconnect negative cable ③ from the 12 V battery.
- Disconnect positive cable ④ from the 12-V battery.
- Take the 12-V battery out of the battery compartment.

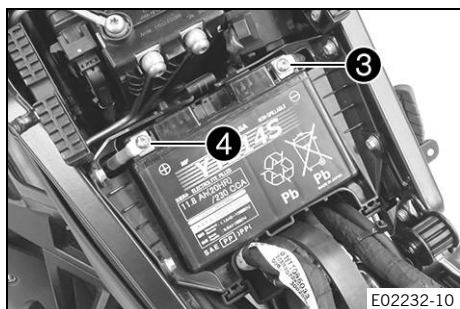

3.11 Installing the 12-V battery



**Warning**

**Risk of injury** Battery acid and battery gases cause serious chemical burns.

- Keep 12 V batteries out of the reach of children.
- Wear suitable protective clothing and safety glasses.
- Avoid contact with battery acid and battery gases.
- Keep sparks or open flames away from the 12 V battery.
- Only charge 12 V batteries in well-ventilated rooms.
- Rinse the affected area immediately with plenty of water in the event of contact with the skin.
- Rinse eyes with water for at least 15 minutes and consult a doctor immediately if battery acid and battery gases get into the eyes.



**Caution**

**Danger of accidents** Electronic components and safety devices will be damaged if the 12-V battery is discharged or missing.

If the 12-V battery is discharged or defective, malfunctions in the vehicle electronics can occur, especially when starting.

- Never operate the vehicle with a discharged 12-V battery or without a 12-V battery.

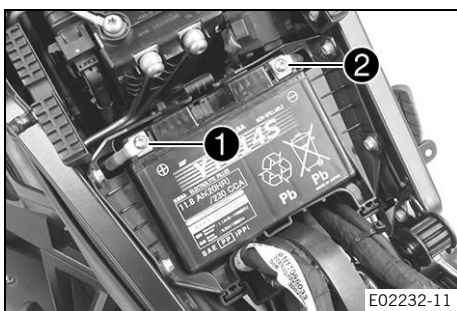

**Main work**

- Position the 12-V battery in the battery compartment.
- Position positive cable ① and mount and tighten the screw.

Guideline

Screw, battery terminal	M6x12	4.5 Nm (3.32 lbf ft)
-------------------------	-------	-------------------------

- Position negative cable ② and mount and tighten the screw.

Guideline

Screw, battery terminal	M6x12	4.5 Nm (3.32 lbf ft)
-------------------------	-------	-------------------------

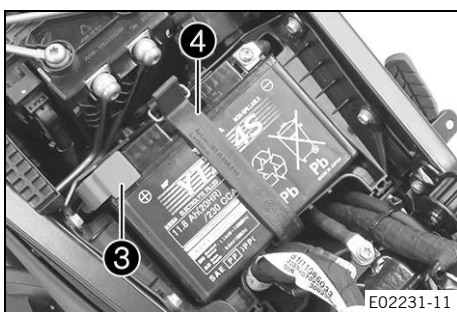

- Mount positive terminal cover ③.
- Attach battery retainer rubber ④.

**Finishing work**

- Mount the front rider's seat. (📖 p. 10)
- Mount the passenger seat. (📖 p. 9)
- Set time and date. (📖 p. 15)



### 3.12 Disconnecting the negative cable of the 12-V battery



#### Warning

**Risk of injury** Battery acid and battery gases cause serious chemical burns.

- Keep 12 V batteries out of the reach of children.
- Wear suitable protective clothing and safety glasses.
- Avoid contact with battery acid and battery gases.
- Keep sparks or open flames away from the 12 V battery.
- Only charge 12 V batteries in well-ventilated rooms.
- Rinse the affected area immediately with plenty of water in the event of contact with the skin.
- Rinse eyes with water for at least 15 minutes and consult a doctor immediately if battery acid and battery gases get into the eyes.



#### Caution

**Danger of accidents** Electronic components and safety devices will be damaged if the 12-V battery is discharged or missing.

If the 12-V battery is discharged or defective, malfunctions in the vehicle electronics can occur, especially when starting.

- Never operate the vehicle with a discharged 12-V battery or without a 12-V battery.

#### Preparatory work

- Remove the passenger seat. (📖 p. 9)
- Remove the front rider's seat. (📖 p. 9)

#### Main work

- Disconnect negative cable ❶ of the 12-V battery.

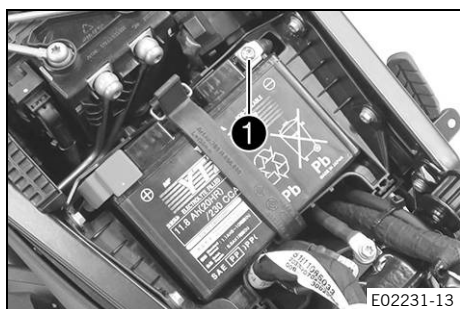

### 3.13 Connecting the negative cable of the 12-V battery



#### Warning

**Risk of injury** Battery acid and battery gases cause serious chemical burns.

- Keep 12 V batteries out of the reach of children.
- Wear suitable protective clothing and safety glasses.
- Avoid contact with battery acid and battery gases.
- Keep sparks or open flames away from the 12 V battery.
- Only charge 12 V batteries in well-ventilated rooms.
- Rinse the affected area immediately with plenty of water in the event of contact with the skin.
- Rinse eyes with water for at least 15 minutes and consult a doctor immediately if battery acid and battery gases get into the eyes.





**Caution**

**Danger of accidents** Electronic components and safety devices will be damaged if the 12-V battery is discharged or missing.

If the 12-V battery is discharged or defective, malfunctions in the vehicle electronics can occur, especially when starting.

- Never operate the vehicle with a discharged 12-V battery or without a 12-V battery.

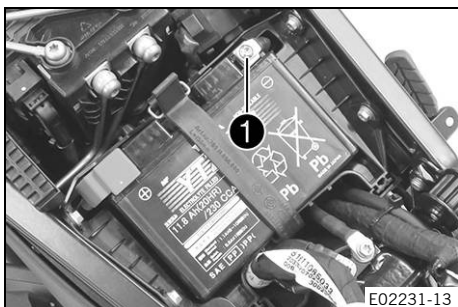

**Main work**

- Position negative cable ① and mount and tighten the screw.

Guideline

Screw, battery terminal	M6x12	4.5 Nm (3.32 lbf ft)
-------------------------	-------	-------------------------

**Finishing work**

- Mount the front rider's seat. (🔧 p. 10)
- Mount the passenger seat. (🔧 p. 9)
- Set time and date.

**3.14 Setting the time and date**

**Condition**

The motorcycle is stationary.

- Press the **SET** button or **RIGHT** button when the menu is closed.
- Press the **UP** button or **DOWN** button until **Settings** is marked.
- Press the **RIGHT** or **SET** button to open the menu.
- Press the **UP** button or **DOWN** button until **Clock & Date** is marked.
- Press the **SET** button to open the menu.

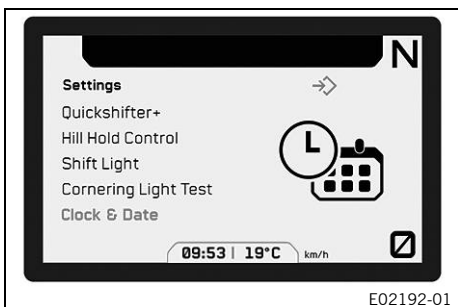

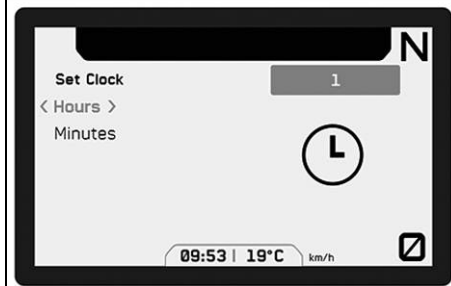
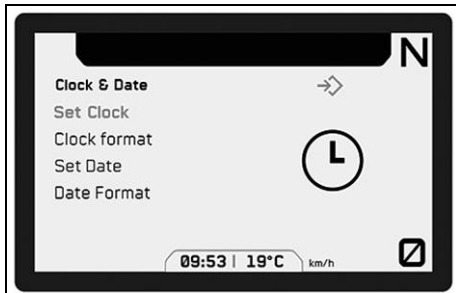

E02193-01

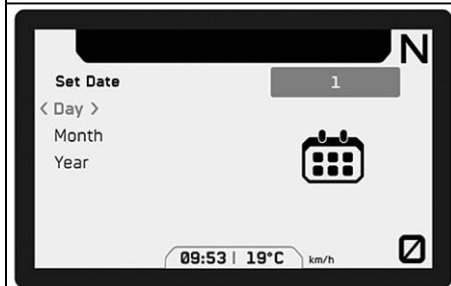
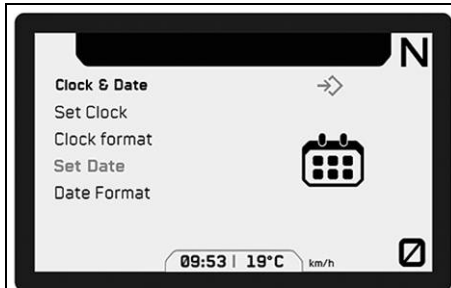

E02194-01

### Setting the clock

- Press the **UP** or **DOWN** button until **Set Clock** is marked.
- Press the **SET** button to open the menu.
- Press the **UP** or **DOWN** button until **Hours** is marked.
- Press the **RIGHT** or **LEFT** button until the current hour is set.
- Press the **UP** or **DOWN** button until **Minutes** is marked.
- Press the **RIGHT** or **LEFT** button until the current minute is set.
- Press the **BACK** button to exit the menu.
- ✓ The time is stored.

### Setting the date

- Press the **UP** or **DOWN** button until **Set Date** is marked.
- Press the **SET** button to open the menu.
- Press the **UP** or **DOWN** button until **Day** is marked.
- Press the **RIGHT** or **LEFT** button until the current day is set.
- Press the **UP** or **DOWN** button until **Month** is marked.
- Press the **RIGHT** or **LEFT** button until the current month is set.
- Press the **UP** or **DOWN** button until **Year** is marked.
- Press the **RIGHT** or **LEFT** button until the current year is set.
- Press the **BACK** button to exit the menu.
- ✓ The date is stored.

## 3.15 Checking the headlight setting

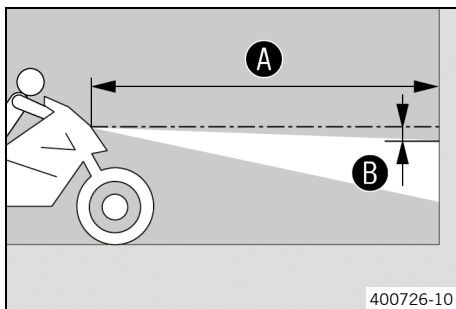

- Park the vehicle on a horizontal surface in front of a light-colored wall and make a mark at the height of the center of the low beam headlight.
- Make another mark at a distance **B** under the first marking.  
Guideline

Distance <b>B</b>	5 cm (2 in)
-------------------	-------------

- Position the vehicle perpendicular to the wall at a distance **A** from the wall and switch on the low beam.

Guideline

Distance <b>A</b>	5 m (16 ft)
-------------------	-------------

- The rider now mounts the motorcycle with luggage and passenger if applicable.
- Check the headlight setting.

The light-dark boundary must be exactly on the lower marking when the motorcycle is ready to be operated with the rider mounted along with any luggage and a passenger if applicable.

- » If the boundary between light and dark does not meet specifications:
  - Adjust the headlight range. (📖 p. 17)



### 3.16 Adjusting the headlight range

**Preparatory work**

- Check the headlight setting. (📖 p. 16)

**Main work**

- Turn adjusting wheel **1** to adjust the headlight range.

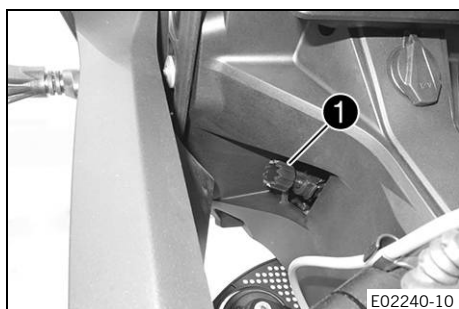

E02240-10

**i Info**  
Turn counterclockwise to increase the headlight range; turn clockwise to reduce the headlight range. If you have a payload, you may have to correct the headlight range.

- Set the headlight to marking **B**.

Guideline

The light-dark boundary must lie exactly on lower marking **B** when the motorcycle is ready to operate with the rider mounted along with any luggage and a passenger if applicable.

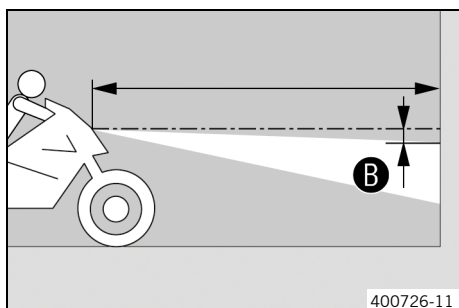

400726-11

### 3.17 Starting



**Danger**

**Danger of poisoning** Exhaust gases are toxic and inhaling them may result in unconsciousness and death.

- Always make sure there is sufficient ventilation when running the engine.
- Use effective exhaust extraction when starting or running the engine in an enclosed space.



### Caution

**Danger of accidents** Electronic components and safety devices will be damaged if the 12-V battery is discharged or missing.

If the 12-V battery is discharged or defective, malfunctions in the vehicle electronics can occur, especially when starting.

- Never operate the vehicle with a discharged 12-V battery or without a 12-V battery.

### Note

**Engine damage** High revving speed with a cold engine negatively impacts the lifespan of the engine.

- Always run the engine warm at a low speed.

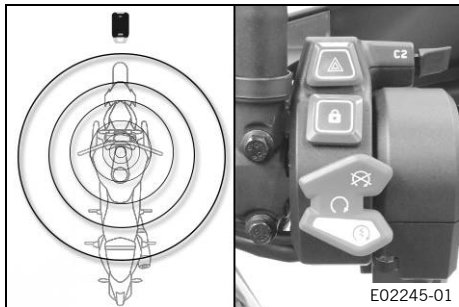

- Take the motorcycle off the side stand and sit on the motorcycle.
- Bring the RACE ON key within range of the antenna.



### Info

If the anti-relay attack is activated, the button on the RACE ON key must be pressed for the RACE ON key to send a response signal.

- Ensure that the RACE ON key stays in range while riding.

#### Guideline

Maximum range of the RACE ON key around the antenna	1.5 m (4.9 ft)
---	----------------



### Info

The range may be reduced by decreases in RACE ON key battery voltage and by interfering radio waves. If the battery voltage of the RACE ON key is too low, one of the ignition keys must be held in the area of the antenna and must be safely stored again after starting.

- Make sure that the start button/emergency OFF switch is in the middle position
- Switch on ignition; to do this, briefly press the RACE-ON button

#### Guideline

To avoid malfunctions in the control unit communication, do not switch the ignition off and on in rapid succession.
---

- ✓ The steering is unlocked.
- ✓ The function check of the combination instrument is run.
- ✓ The ABS warning lamp goes out when starting off.



### Tip

If the steering does not unlock, move the handlebar slightly.

- Shift the transmission into neutral
- ✓ The green idle indicator lamp



- Briefly press the start button/emergency OFF switch into the lower position (⌚).

**i Info**  
 Only press the start button/emergency OFF switch into the lower position (⌚) when the combination instrument function control has been completed.  
 Do not open the throttle to start.  
 If the starting attempt is unsuccessful, wait for 15 seconds before making another attempt at starting.  
 After 6 unsuccessful starting attempts, do not try again, and check the vehicle for other errors instead.  
 This motorcycle is equipped with a safety starting system. You can only start the engine if the transmission is in neutral or if the clutch lever is pulled when a gear is engaged. If the side stand is folded out and you shift into gear, the engine stops.

**3.18 Opening fuel tank filler cap**

**! Danger**  
**Fire hazard** Fuel is highly flammable.  
 The fuel in the fuel tank expands when warm and can escape if overfilled.

- Do not fuel the vehicle in the vicinity of open flames or lit cigarettes.
- Switch off the engine for refueling.
- Make sure that no fuel is spilled; particularly not on hot parts of the vehicle.
- If any fuel is spilled, wipe it off immediately.
- Observe the specifications for refueling.

**! Warning**  
**Danger of poisoning** Fuel is poisonous and a health hazard.

- Avoid skin, eye and clothing contact with fuel.
- Immediately consult a doctor if you swallow fuel.
- Do not inhale fuel vapors.
- In case of skin contact, rinse the affected area with plenty of water.
- Rinse the eyes thoroughly with water, and consult a doctor in case of fuel contact with the eyes.
- Change your clothing in case of fuel spills on them.
- Keep fuels correctly in a suitable canister, and out of the reach of children.

**🌸 Note**  
**Environmental hazard** Improper handling of fuel is a danger to the environment.

- Do not allow fuel to enter the groundwater, the soil, or the sewage system.

**Condition**  
 The motorcycle is stationary.  
 The engine is off.  
 The ignition has been switched on or off for less than 1 minute.

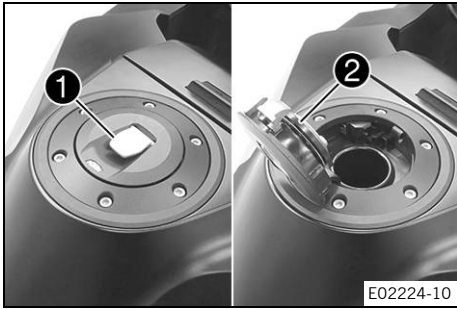

- Fold up cover **1** slowly.
- ✓ The fuel tank filler cap is unlocked.
- Fold up fuel tank filler cap **2**.

## 3.19 Closing the fuel tank filler cap

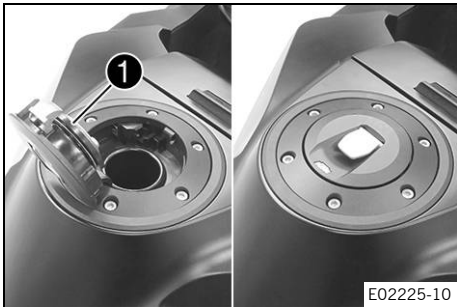

### Warning

**Fire hazard** Fuel is highly flammable, toxic and a health hazard.

- Check that the fuel tank filler cap is locked correctly after closing.
- Change your clothing if fuel spills on them.
- Rinse the affected area immediately with plenty of water in the event of contact with the skin.

- Fold down fuel tank filler cap **1** and push it down.
- ✓ The fuel tank filler cap locks audibly in place.

## 3.20 Refueling



### Danger

**Fire hazard** Fuel is highly flammable.

The fuel in the fuel tank expands when warm and can escape if overfilled.

- Do not fuel the vehicle in the vicinity of open flames or lit cigarettes.
- Switch off the engine for refueling.
- Make sure that no fuel is spilled; particularly not on hot parts of the vehicle.
- If any fuel is spilled, wipe it off immediately.
- Observe the specifications for refueling.



### Warning

**Danger of poisoning** Fuel is poisonous and a health hazard.

- Avoid skin, eye and clothing contact with fuel.
- Immediately consult a doctor if you swallow fuel.
- Do not inhale fuel vapors.
- In case of skin contact, rinse the affected area with plenty of water.
- Rinse the eyes thoroughly with water, and consult a doctor in case of fuel contact with the eyes.
- Change your clothing in case of fuel spills on them.

### Note

**Material damage** Inadequate fuel quality causes the fuel filter to quickly become clogged.

In some countries and regions, the available fuel quality and cleanliness may not be sufficient. This will result in problems with the fuel system.

- Refuel only with clean fuel that meets the specified standards.



**Note**

**Environmental hazard** Improper handling of fuel is a danger to the environment.

- Do not allow fuel to enter the groundwater, the soil, or the sewage system.

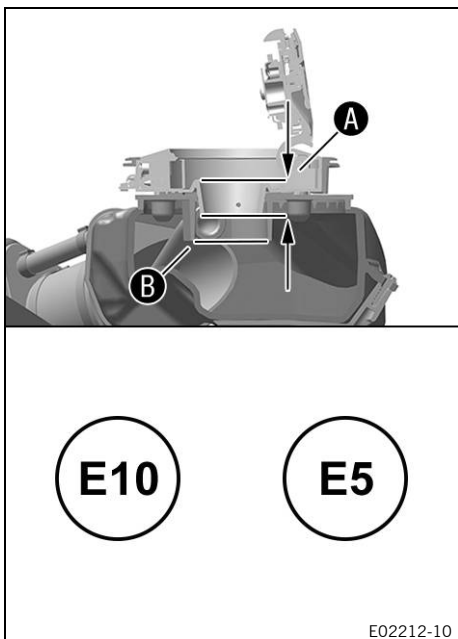

- Switch off the engine.
- Open the fuel tank filler cap. (📖 p. 19)
- Only insert the fuel nozzle to the specified dimension.

Guideline

Dimension <b>A</b>	2.5 cm (0.98 in)
--------------------	------------------

- Fill the fuel up to the maximum level at lower edge **B** of the filler neck.

Guideline

After filling up to the lower edge of the filler neck for the first time, do not refuel again.

Total fuel tank capacity, approx.	23 l (6.1 US gal)	Super unleaded (ROZ 95) (📖 p. 26)
-----------------------------------	----------------------	---

**i Info**

After the first filling, the contents of the reservoir slowly flows into the fuel tank.

If refueling is performed again after draining, the fuel tank will overflow and the evaporative canister will be destroyed.

- Close the fuel tank filler cap. (📖 p. 20)



## 4 TECHNICAL DATA

### 4.1 Chassis tightening torques

Clamp distributor on the tank half		3 Nm (2.2 lbf ft)	
Cover, brake reservoir, rear		3.5 Nm (2.58 lbf ft)	
Radiator hose clamp		2.4 Nm (1.77 lbf ft)	
Screw, ball-head headlight holder	<b>EJOT Altracs 5151®</b> 50x12	7 Nm (5.2 lbf ft)	
Screw, front brake reservoir cover		1 Nm (0.7 lbf ft)	
Screw, oil filler neck on frame	<b>EJOT PT®</b> 50x14	2.8 Nm (2.07 lbf ft)	
Screw, tail light	<b>EJOT PT®</b> K40x18	2 Nm (1.5 lbf ft)	
Sleeve nut, fuel level sensor		15 Nm (11.1 lbf ft)	
Screw, fixed grip, left	M4x12	3 Nm (2.2 lbf ft)	
Screw, license plate lamp	M4	0.5 Nm (0.37 lbf ft)	
Screw, side stand sensor	M4x12 – 8.8	2 Nm (1.5 lbf ft)	<b>Loctite®243™</b>
Remaining nuts, chassis	M5	5 Nm (3.7 lbf ft)	
Remaining screws, chassis	M5	5 Nm (3.7 lbf ft)	
Screw, brake hose bracket	M5	2 Nm (1.5 lbf ft)	
Screw, brake line guide / cable bracket on swingarm	M5x10	5 Nm (3.7 lbf ft)	
Screw, brake reservoir, rear brake	M5	3.5 Nm (2.58 lbf ft)	<b>Loctite®243™</b>
Screw, chain sliding guard	M5x10	5 Nm (3.7 lbf ft)	
Screw, combination instrument	M5x8	1 Nm (0.7 lbf ft)	
Screw, combination switch, left	M5	5 Nm (3.7 lbf ft)	
Screw, combination switch, right	M5	5 Nm (3.7 lbf ft)	
Screw, connector support, fuel tank bracket	M5x10	3.5 Nm (2.58 lbf ft)	
Screw, coolant compensating tank	M5x12	3.5 Nm (2.58 lbf ft)	
Screw, cover part	M5x12	3.5 Nm (2.58 lbf ft)	
Screw, cover part	M5	3.5 Nm (2.58 lbf ft)	
Screw, front tank protector	M5x22	2.5 Nm (1.84 lbf ft)	
Screw, fuel tank cap	M5x25	3.5 Nm (2.58 lbf ft)	<b>Loctite®243™</b>
Screw, headlight adjuster	M5x14	3.5 Nm (2.58 lbf ft)	
Screw, headlight mask	M5x12	3.5 Nm (2.58 lbf ft)	
Screw, heat shield on silencer	M5x14	5 Nm (3.7 lbf ft)	
Screw, instrument support	M5x12	3.5 Nm (2.58 lbf ft)	
Screw, light control unit bracket	M5x12	3.5 Nm (2.58 lbf ft)	
Screw, mask support	M5x12	3.5 Nm (2.58 lbf ft)	
Screw, radiator connection bracket	M5x10	2.8 Nm (2.07 lbf ft)	
Screw, radiator cover	M5x12	2.5 Nm (1.84 lbf ft)	
Screw, rear brake lever stub	M5x16	5 Nm (3.7 lbf ft)	<b>Loctite®243™</b>
Screw, rear cellphone storage compartment	M5x12	3.5 Nm (2.58 lbf ft)	
Screw, rear tank protector, long	M5x17	3 Nm (2.2 lbf ft)	
Screw, rear tank protector, short	M5x12	3 Nm (2.2 lbf ft)	



Screw, sliding seat bushing, windshield	M5x20	4 Nm (3 lbf ft)
Screw, splash protection, tail end lower part	M5x12	3 Nm (2.2 lbf ft)
Screw, throttle	M5x25	3.5 Nm (2.58 lbf ft)
Screw, top mask spoiler, fuel tank fairing	M5x12	2.5 Nm (1.84 lbf ft)
Screw, windshield	M5x14	3.5 Nm (2.58 lbf ft)
Screw, wiring harness cable guide	M5x12	5 Nm (3.7 lbf ft)
Tire air pressure sensor (SUPER ADVENTURE S EU/CN, 1290 SUPER ADVENTURE S US)	M5x15	2.4 Nm (1.77 lbf ft)
Clamp, header/silencer	M6	10 Nm (7.4 lbf ft)
Ground fitting on frame	M6x16	6 Nm (4.4 lbf ft)
Nut, windshield holder on sliding seat shaft	M6	5 Nm (3.7 lbf ft)
Remaining nuts, chassis	M6	10 Nm (7.4 lbf ft)
Remaining screws, chassis	M6	10 Nm (7.4 lbf ft)
Screw, 6-D sensor	M6x15	6 Nm (4.4 lbf ft)
		<b>Loctite®243™</b>
Screw, 6-D sensor retaining bracket	M6x16	10 Nm (7.4 lbf ft)
Screw, ABS modulator fastening	M6x16	8 Nm (5.9 lbf ft)
Screw, ball joint of push rod on foot brake cylinder	M6	10 Nm (7.4 lbf ft)
		<b>Loctite®243™</b>
Screw, battery terminal	M6x12	4.5 Nm (3.32 lbf ft)
Screw, bottom triple clamp cover	M6x12	6 Nm (4.4 lbf ft)
Screw, brake assembly	M6	5 Nm (3.7 lbf ft)
Screw, clutch lever assembly	M6x25	5 Nm (3.7 lbf ft)
Screw, combination instrument support	M6x18	10 Nm (7.4 lbf ft)
		<b>Loctite®243™</b>
Screw, cover part	M6	6 Nm (4.4 lbf ft)
Screw, engine guard	M6	10 Nm (7.4 lbf ft)
Screw, front brake disc	M6	14 Nm (10.3 lbf ft)
		<b>Loctite®243™</b>
Screw, front cellphone storage compartment	M6x14	6 Nm (4.4 lbf ft)
Screw, front radar sensor	M6x20	5 Nm (3.7 lbf ft)
Screw, front sprocket cover	M6x25	9 Nm (6.6 lbf ft)
Screw, front wheel speed sensor	M6x16	8 Nm (5.9 lbf ft)
Screw, fuel petcock	M6x12	6 Nm (4.4 lbf ft)
Screw, fuel pump	M6x16	6 Nm (4.4 lbf ft)
Screw, fuel tank on carrier, long	M6x15	6 Nm (4.4 lbf ft)
Screw, fuel tank on carrier, short	M6x12	6 Nm (4.4 lbf ft)
Screw, header clamp, rear	M6x25	8 Nm (5.9 lbf ft)
Screw, headlight on mask support	M6x20	8 Nm (5.9 lbf ft)
Screw, preload adjuster clamp	M6	6 Nm (4.4 lbf ft)
Screw, preload adjuster on bracket	M6	6 Nm (4.4 lbf ft)

## 4 TECHNICAL DATA

Screw, rear brake disc	M6	14 Nm (10.3 lbf ft) <b>Loctite®243™</b>
Screw, rear cover	M6x16	6 Nm (4.4 lbf ft)
Screw, rear master cylinder	M6x25	10 Nm (7.4 lbf ft) <b>Loctite®243™</b>
Screw, rear wheel speed sensor	M6x16	8 Nm (5.9 lbf ft)
Screw, seat bushing	M6x16	4 Nm (3 lbf ft)
Screw, starter relay cable	M6x12	6 Nm (4.4 lbf ft)
Screw, tank mask spoiler	M6x12	6 Nm (4.4 lbf ft)
Screw, voltage regulator	M6x25	6 Nm (4.4 lbf ft)
Remaining nuts, chassis	M8	25 Nm (18.4 lbf ft)
Remaining screws, chassis	M8	25 Nm (18.4 lbf ft)
Screw, bottom triple clamp	M8x35	15 Nm (11.1 lbf ft)
Screw, engine brace frame	M8x20	25 Nm (18.4 lbf ft) <b>Loctite®243™</b>
Screw, footrest bracket, rear	M8x25	25 Nm (18.4 lbf ft) <b>Loctite®243™</b>
Screw, fork shoe	M8x20	15 Nm (11.1 lbf ft)
Screw, front footrest bracket	M8x20	25 Nm (18.4 lbf ft) <b>Loctite®243™</b>
Screw, handle bar end hand guard	M8x40	25 Nm (18.4 lbf ft)
Screw, handlebar clamp	M8x25	20 Nm (14.8 lbf ft)
Screw, ignition lock (tamper-proof screw)	M8	25 Nm (18.4 lbf ft) <b>Loctite®243™</b>
Screw, side stand bracket on engine	M8x25	25 Nm (18.4 lbf ft) <b>Loctite®243™</b>
Screw, stand spring pin	M8	15 Nm (11.1 lbf ft)
Screw, steering damper on frame	M8x20	25 Nm (18.4 lbf ft) <b>Loctite®243™</b>
Screw, steering damper on triple clamp	M8x25	25 Nm (18.4 lbf ft) <b>Loctite®243™</b>
Screw, steering stem clamp	M8x35	20 Nm (14.8 lbf ft)
Screw, top case carrier	M8x40	25 Nm (18.4 lbf ft)
Screw, top triple clamp	M8x35	20 Nm (14.8 lbf ft)
Screw, fuel tank rubber support	M8x1.25	20 Nm (14.8 lbf ft)
Remaining nuts, chassis	M10	45 Nm (33.2 lbf ft)
Remaining screws, chassis	M10	45 Nm (33.2 lbf ft)
Screw, engine brace frame	M10x50	45 Nm (33.2 lbf ft) <b>Loctite®243™</b>
Screw, handlebar mount	M10x35	40 Nm (29.5 lbf ft) <b>Loctite®243™</b>
Screw, rear brake lever	M10x35	25 Nm (18.4 lbf ft) <b>Loctite®243™</b>
Screw, side stand	M10	40 Nm (29.5 lbf ft) <b>Loctite®243™</b>
Screw, side stand bracket	M10x30	55 Nm (40.6 lbf ft) <b>Loctite®243™</b>
Screw, subframe	M10x20	45 Nm (33.2 lbf ft)
Banjo bolt, brake line	M10x1	25 Nm (18.4 lbf ft)

Nut, rear sprocket screw	M10x1.25	50 Nm (36.9 lbf ft) <b>Loctite®243™</b>
Nut, turn signal	M10x1.25	4 Nm (3 lbf ft)
Screw, front brake caliper	M10x1.5x55	45 Nm (33.2 lbf ft) <b>Loctite®243™</b>
Lambda sensor	M12x1.25	25 Nm (18.4 lbf ft)
Screw, bottom shock absorber	M14x1.5	80 Nm (59 lbf ft) Thread greased
Screw, top shock absorber	M14x1.5	80 Nm (59 lbf ft) Thread greased
Nut, socket	M18x1	4 Nm (3 lbf ft)
Nut, fork pivot	M19x1.5	130 Nm (95.9 lbf ft) Thread greased
Screw, steering head, top	M22x1.5	18 Nm (13.3 lbf ft)
Nut, rear wheel spindle	M25x1.5	90 Nm (66.4 lbf ft) Thread greased
Screw, front wheel spindle	M25x1.5	45 Nm (33.2 lbf ft) Thread greased

## Super unleaded (ROZ 95)

### Standard/classification

- DIN EN 228 (ROZ 95)

### Guideline

- Only use super unleaded fuel that matches or is equivalent to the specified standard.
- Fuel with an ethanol content of up to 10% (E10 fuel) is safe to use.



### Info

Do **not** use fuel containing methanol (e.g., M15, M85, M100) or more than 10% ethanol (e.g., E15, E25, E85, E100).

---



3214614en

01/2022

