

450 EXC-F
450 EXC-F SIX DAYS
450 XCF-W
500 EXC-F
500 EXC-F SIX DAYS

ART. NO. 3214649EN



Congratulations on your decision to purchase a KTM motorcycle. You are now the owner of a state-of-the-art sports vehicle which, with appropriate care, will bring you pleasure for a long time to come.

We wish you good and safe riding at all times!

Please enter the serial number of your vehicle below.

Vehicle identification number (📖 p. 14)	Stamp of dealer
Engine number (📖 p. 15)	
Key number (All EU models) (📖 p. 15)	

The Owner's Manual contained the latest information for this model series at the time of publication. Slight deviations resulting from continuing development and design of the motorcycles cannot, however, be completely excluded.

All specifications contained herein are non-binding. KTM Sportmotorcycle GmbH specifically reserves the right to modify or delete technical specifications, prices, colors, forms, materials, services, designs, equipment, etc., without prior notice and without specifying reasons, to adapt these to local conditions, as well as to stop production of a particular model without prior notice. KTM accepts no liability for delivery options, deviations from figures and descriptions, misprints, and other errors. The models portrayed partly contain special equipment that does not belong to the regular scope of supply.

© 2022 KTM Sportmotorcycle GmbH, Mattighofen Austria

All rights reserved

Reproduction, even in part, as well as copying of all kinds, is permitted only with the express written permission of the copyright owner.



ISO 9001(12 100 6061)

KTM applies quality assurance processes that lead to the highest possible product quality as defined in the ISO 9001 international quality management standard.

Issued by: TÜV Management Service

REG.NO. 12 100 6061

KTM Sportmotorcycle GmbH
Stallhofnerstraße 3
5230 Mattighofen, Austria

This document is valid for the following models:

450 EXC-F EU (F8403W9)

450 EXC-F SIX DAYS EU (F8403W2)

450 XCF-W US (F8475W2)

500 EXC-F EU (F8503W9)

500 EXC-F SIX DAYS EU (F8503W2)



3214649en

07.04.2022

TABLE OF CONTENTS

1	MEANS OF REPRESENTATION	6	6.13	Overview of indicator lamps (XCF-W)	19
1.1	Symbols used	6	6.14	Opening fuel tank filler cap	20
1.2	Formats used	6	6.15	Closing the fuel tank filler cap	20
2	SAFETY ADVICE	7	6.16	Cold start button	21
2.1	Use definition – intended use	7	6.17	Idle speed adjusting screw	21
2.2	Misuse	7	6.18	Shift lever	22
2.3	Safety advice	7	6.19	Foot brake lever	22
2.4	Degrees of risk and symbols	8	6.20	Side stand	22
2.5	Tampering warning	8	6.21	Steering lock (All EU models)	23
2.6	Safe operation	8	6.22	Locking the steering (All EU models)	23
2.7	Protective clothing	9	6.23	Unlocking the steering (All EU models)	24
2.8	Work rules	9	7	COMBINATION INSTRUMENT	25
2.9	Environment	9	7.1	Combination instrument overview	25
2.10	Owner's Manual	10	7.2	Activation and test	25
3	IMPORTANT NOTES	11	7.3	Setting kilometers or miles	25
3.1	Manufacturer warranty, implied warranty	11	7.4	Setting the combination instrument	26
3.2	Fuel, auxiliary substances	11	7.5	Setting the clock	26
3.3	Spare parts, technical accessories	11	7.6	Viewing the lap time	27
3.4	Service	11	7.7	Display mode SPEED (speed)	28
3.5	Figures	11	7.8	Display mode SPEED/H (operating hours)	28
3.6	Customer service	11	7.9	Setup menu	28
4	VIEW OF VEHICLE	12	7.10	Adjusting the unit of measurement	29
4.1	View of vehicle, front left (example)	12	7.11	Display mode SPEED/CLK (time)	30
4.2	View of vehicle, rear right (example)	13	7.12	Setting the clock	30
5	SERIAL NUMBERS	14	7.13	Display mode SPEED/LAP (lap time)	30
5.1	Vehicle identification number	14	7.14	Viewing the lap time	31
5.2	Type label	14	7.15	Display mode SPEED/ODO (odometer)	31
5.3	Key number (All EU models)	15	7.16	Display mode SPEED/TR1 (trip master 1)	32
5.4	Engine number	15	7.17	Display mode SPEED/TR2 (trip master 2)	32
5.5	Fork part number	15	7.18	Adjusting TR2 (trip master 2)	32
5.6	Shock absorber article number	15	7.19	Display mode SPEED/A1 (average speed 1)	33
6	CONTROLS	16	7.20	Display mode SPEED/A2 (average speed 2)	33
6.1	Clutch lever	16	7.21	Display mode SPEED/S1 (stop watch 1)	34
6.2	Hand brake lever	16	7.22	Display mode SPEED/S2 (stop watch 2)	34
6.3	Throttle grip	16	7.23	Table of functions	34
6.4	Stop button	16	7.24	Table of conditions and menu activation	36
6.5	Horn button (All EU models)	17	8	PREPARING FOR USE	37
6.6	Light switch (All EU models)	17	8.1	Advice on preparing for first use	37
6.7	Light switch (XCF-W)	17	8.2	Running-in the engine	38
6.8	Turn signal switch (All EU models)	18	8.3	Starting power of lithium-ion batteries at low temperatures	39
6.9	Emergency OFF switch	18			
6.10	Start button	18			
6.11	Combination switch (EXC-F SIX DAYS, XCF-W)	19			
6.12	Overview of indicator lamps (All EU models)	19			

8.4	Preparing the vehicle for difficult operating conditions.....	39	11.13	Adjusting the rebound damping of the fork.....	58
8.5	Preparing the vehicle for riding on dry sand.....	39	11.14	Adjusting the spring preload of the fork	59
8.6	Preparing the vehicle for riding on wet sand	40	11.15	Handlebar position.....	60
8.7	Preparing the vehicle for riding on wet and muddy circuits	41	11.16	Adjusting the handlebar position 🛠️.....	60
8.8	Preparing vehicle for high temperatures or slow riding.....	41	12	SERVICE WORK ON THE CHASSIS.....	63
8.9	Preparing the vehicle for low temperatures or snow	42	12.1	Raising the motorcycle with the lift stand	63
9	RIDING INSTRUCTIONS.....	43	12.2	Removing the motorcycle from the lift stand	63
9.1	Checks and maintenance measures when preparing for use	43	12.3	Bleeding the fork legs.....	63
9.2	Starting the vehicle.....	43	12.4	Cleaning the dust boots of the fork legs	64
9.3	Activating traction control (EXC-F SIX DAYS, XCF-W).....	44	12.5	Removing the fork protector	64
9.4	Starting off.....	45	12.6	Installing the fork protector.....	65
9.5	Shifting, riding	45	12.7	Removing the fork legs 🛠️.....	65
9.6	Braking.....	45	12.8	Installing the fork legs 🛠️.....	66
9.7	Stopping, parking.....	46	12.9	Removing the lower triple clamp 🛠️ (EXC-F EU, XCF-W)	67
9.8	Transporting	47	12.10	Removing the lower triple clamp 🛠️ (EXC-F SIX DAYS EU).....	68
9.9	Refueling	47	12.11	Installing the lower triple clamp 🛠️ (EXC-F EU, XCF-W)	68
10	SERVICE SCHEDULE	49	12.12	Installing the lower triple clamp 🛠️ (EXC-F SIX DAYS EU).....	70
10.1	Additional information	49	12.13	Checking steering head bearing play	72
10.2	Required work	49	12.14	Adjusting the steering head bearing play 🛠️ (EXC-F EU, XCF-W).....	73
10.3	Recommended work	50	12.15	Adjusting the steering head bearing play 🛠️ (EXC-F SIX DAYS EU)	73
11	TUNING THE CHASSIS	52	12.16	Lubricating the steering head bearing 🛠️.....	74
11.1	Checking the basic chassis setting with rider's weight.....	52	12.17	Removing front fender.....	74
11.2	Compression damping of the shock absorber.....	52	12.18	Installing front fender.....	75
11.3	Adjusting the low-speed compression damping of the shock absorber.....	52	12.19	Removing the shock absorber 🛠️.....	76
11.4	Adjusting the high-speed compression damping of the shock absorber.....	53	12.20	Installing the shock absorber 🛠️.....	76
11.5	Adjusting the rebound damping of the shock absorber.....	54	12.21	Removing the seat	77
11.6	Measuring the dimension of the rear wheel unloaded.....	54	12.22	Mounting the seat	77
11.7	Checking the static sag of the shock absorber.....	55	12.23	Removing the air filter box cover	78
11.8	Checking the riding sag of the shock absorber.....	55	12.24	Installing the air filter box cover	79
11.9	Adjusting the spring preload of the shock absorber 🛠️.....	56	12.25	Removing the air filter 🛠️.....	79
11.10	Adjusting the riding sag 🛠️.....	57	12.26	Installing the air filter 🛠️.....	80
11.11	Checking the basic setting of the fork	57	12.27	Cleaning the air filter and air filter box 🛠️.....	80
11.12	Adjusting the compression damping of the fork	58	12.28	Preparing air filter box cover for securing 🛠️.....	81
			12.29	Removing the main silencer	81
			12.30	Installing the main silencer.....	82
			12.31	Cleaning the spark arrestor 🛠️ (XCF-W)	82
			12.32	Changing the glass fiber yarn filling of the main silencer 🛠️.....	84
			12.33	Removing the fuel tank 🛠️.....	85

TABLE OF CONTENTS

12.34	Installing the fuel tank	86	15.4	Changing main fuse	123
12.35	Checking for chain dirt accumulation	88	15.5	Changing the fuses of individual electrical power consumers	124
12.36	Cleaning the chain	88	15.6	Removing the headlight mask with the headlight	125
12.37	Checking the chain tension	89	15.7	Installing the headlight mask with the headlight	126
12.38	Adjusting the chain tension	90	15.8	Changing the headlight bulb	126
12.39	Checking the chain, rear sprocket, engine sprocket, and chain guide	91	15.9	Checking the headlight setting	127
12.40	Checking the frame	93	15.10	Adjusting the headlight range	128
12.41	Checking the link fork	93	15.11	Changing the turn signal bulb (All EU models)	128
12.42	Checking the throttle cable routing	93	15.12	Changing the combination instrument battery	129
12.43	Checking the rubber grip	94	15.13	Diagnostics connector	130
12.44	Adjusting the basic position of the clutch lever	95	16	COOLING SYSTEM	131
12.45	Checking/correcting the fluid level of the hydraulic clutch	95	16.1	Cooling system	131
12.46	Changing the hydraulic clutch fluid	96	16.2	Checking the antifreeze and coolant level	131
12.47	Removing the engine guard (EXC-F SIX DAYS, XCF-W)	97	16.3	Checking the coolant level	132
12.48	Installing the engine guard (EXC-F SIX DAYS, XCF-W)	98	16.4	Draining the coolant	133
13	BRAKE SYSTEM	99	16.5	Refilling coolant	134
13.1	Adjusting the basic position of the hand brake lever	99	16.6	Changing the coolant	134
13.2	Checking the brake discs	99	17	TUNING THE ENGINE	136
13.3	Checking the front brake fluid level	100	17.1	Checking the play in the throttle cable	136
13.4	Adding the front brake fluid	100	17.2	Adjusting the play in the throttle cable	136
13.5	Checking the front brake linings	102	17.3	Adjusting the characteristic map of the throttle response	137
13.6	Changing the brake linings of the front brake	102	17.4	Changing the mapping (EXC-F SIX DAYS, XCF-W)	138
13.7	Checking the free travel of foot brake lever	106	17.5	Adjusting the idle speed	139
13.8	Adjusting the basic position of the foot brake lever	107	17.6	Teaching the throttle valve position	140
13.9	Checking the rear brake fluid level	108	17.7	Checking the basic position of the shift lever	140
13.10	Adding rear brake fluid	108	17.8	Adjusting the basic position of the shift lever	141
13.11	Checking the rear brake linings	109	18	SERVICE WORK ON THE ENGINE	142
13.12	Changing the rear brake linings	110	18.1	Changing the fuel screen	142
14	WHEELS, TIRES	113	18.2	Checking the engine oil level	143
14.1	Removing the front wheel	113	18.3	Changing the engine oil and oil filter, cleaning the oil screens	143
14.2	Installing the front wheel	114	18.4	Adding engine oil	146
14.3	Removing the rear wheel	114	19	CLEANING, CARE	147
14.4	Installing the rear wheel	115	19.1	Cleaning the motorcycle	147
14.5	Checking the tire condition	117	19.2	Checks and maintenance steps for winter operation	148
14.6	Checking tire pressure	117	20	STORAGE	149
14.7	Checking spoke tension	118	20.1	Storage	149
15	ELECTRICAL SYSTEM	119			
15.1	Removing the 12-V battery	119			
15.2	Installing the 12-V battery	120			
15.3	Charging the 12-V battery	121			

20.2	Preparing for use after storage.....	150
21	TROUBLESHOOTING	151
22	BLINK CODE	154
23	TECHNICAL DATA.....	156
23.1	Engine	156
23.2	Engine tightening torques	157
23.3	Capacities	158
23.3.1	Engine oil	158
23.3.2	Coolant	158
23.3.3	Fuel	158
23.4	Chassis	159
23.5	Electrical system.....	160
23.6	Tires	160
23.7	Fork.....	160
23.8	Shock absorber	161
23.9	Chassis tightening torques	162
24	SUBSTANCES	164
25	AUXILIARY SUBSTANCES	166
26	STANDARDS	168
27	INDEX OF SPECIAL TERMS	169
28	LIST OF ABBREVIATIONS.....	170
29	LIST OF SYMBOLS.....	171
29.1	Yellow and orange symbols.....	171
29.2	Green and blue symbols.....	171
INDEX	172

1 MEANS OF REPRESENTATION

1.1 Symbols used

The meaning of specific symbols is described below.



Indicates an expected reaction (e.g. of a work step or a function).



Indicates an unexpected reaction (e.g. of a work step or a function).



Indicates work that requires expert knowledge and technical understanding. In the interest of your own safety, have these jobs performed by an authorized KTM workshop! Your motorcycle will be cared for there to the highest degree by specially trained experts using the special tools required.



Indicates a page reference (more information is provided on the specified page).



Indicates information with more details or tips.



Indicates the result of a testing step.



Indicates a voltage measurement.



Indicates a current measurement.



Indicates the end of an activity, including potential rework.

1.2 Formats used

The typographical formats used in this document are explained below.

Proprietary name

Indicates a proprietary name.

Name®

Indicates a protected name.

Brand™

Indicates a brand available on the open market.

Underlined terms

Refer to technical details of the vehicle or indicate technical terms, which are explained in the glossary.

2.1 Use definition – intended use

(All EU models)

This vehicle has been designed and built to withstand the normal stresses and strains of racing. This vehicle complies with the currently valid regulations and categories of the top international motorsports organizations.



Info

This vehicle is only authorized for operation on public roads in the homologated (restricted) version. The derestricted version of this vehicle must only be operated in closed off areas away from public highway traffic.

This vehicle is designed for use in offroad endurance competition, and not primarily for use in motocross.

(XCF-W)

This vehicle has been designed and built to withstand the normal stresses and strains of offroad leisure use.



Info

This vehicle is not approved for use on public roads.

This vehicle complies with the Californian and EPA emission requirements for offroad motorcycles.

This vehicle is not designed for use in racing on closed circuits or for Motocross use.

2.2 Misuse

The vehicle must only be used as intended.

Dangers can arise for people, property and the environment through use not as intended.

Any use of the vehicle beyond the intended and defined use constitutes misuse.

Misuse also includes the use of operating and auxiliary fluids which do not meet the required specification for the respective use.

2.3 Safety advice

A number of safety instructions need to be followed to operate the product described safely. Therefore read this instruction and all further instructions included carefully. The safety instructions are highlighted in the text and are referred to at the relevant passages.



Info

Various information and warning labels are attached in prominent locations on the product described. Do not remove any information or warning labels. If they are missing, you or others may not recognize dangers and may therefore be injured.

2.4 Degrees of risk and symbols



Danger

Identifies a danger that will immediately and invariably lead to fatal or serious permanent injury if the appropriate measures are not taken.



Warning

Identifies a danger that is likely to lead to fatal or serious injury if the appropriate measures are not taken.



Caution

Identifies a danger that may lead to minor injuries if the appropriate measures are not taken.

Note

Identifies a danger that will lead to considerable machine and material damage if the appropriate measures are not taken.



Note

Indicates a danger that will lead to environmental damage if the appropriate measures are not taken.

2.5 Tampering warning

Tampering with the noise control system is prohibited. Federal law prohibits the following acts or the causing thereof:

- 1 The removal or rendering inoperative by any person other than for purposes of servicing, repair, or replacement, of any device or element of design incorporated into any new vehicle for the purpose of noise control prior to its sale or delivery to the ultimate purchaser or while it is in use, or
- 2 the use of the vehicle after such device or element of design has been removed or rendered inoperative by any person.

Among those acts presumed to constitute tampering are the acts listed below:

- 1 Removal or puncturing of the main silencers, baffles, manifolds or any other components which conduct exhaust gases.
- 2 Removal or puncturing of parts of the intake system.
- 3 Lack of proper maintenance.
- 4 Replacing moving parts of the vehicle, or parts of the exhaust system or intake system, with parts other than those specified by the manufacturer.

(XCF-W)

An add-on or modified part must be compliant with applicable ARB evaporative emission control standards. A violation of this requirement is punishable by civil and/or criminal punishment.

2.6 Safe operation



Danger

Danger of accidents A rider who is not fit to ride poses a danger to him or herself and others.

- Do not operate the vehicle if you are not fit to ride due to alcohol, drugs or medication.
- Do not operate the vehicle if you are physically or mentally impaired.



Danger

Danger of poisoning Exhaust gases are toxic and inhaling them may result in unconsciousness and death.

- Always make sure there is sufficient ventilation when running the engine.
- Use effective exhaust extraction when starting or running the engine in an enclosed space.

**Warning**

Danger of burns Some vehicle components become very hot when the vehicle is operated.

- Do not touch any parts such as the exhaust system, radiator, engine, shock absorber, or brake system before the vehicle parts have cooled down.
- Let the vehicle parts cool down before you perform any work on the vehicle.

Only operate the vehicle when it is in perfect technical condition, in accordance with its intended use, and in a safe and environmentally compatible manner.

An appropriate driver's license is needed to ride the vehicle on public roads.

Have malfunctions that impair safety promptly eliminated by an authorized KTM workshop.

Adhere to the information and warning labels on the vehicle.

2.7 Protective clothing

**Warning**

Risk of injury Missing or poor protective clothing presents an increased safety risk.

- Wear appropriate protective clothing such as helmet, boots, gloves as well as trousers and a jacket with protectors on all rides.
- Always wear protective clothing that is in good condition and meets the legal regulations.

In the interest of your own safety, KTM recommends that you only operate the vehicle while wearing protective clothing.

2.8 Work rules

Unless specified otherwise, the ignition must be turned off during all work (models with ignition lock, models with remote key) or the engine must be at a standstill (models without ignition lock or remote key).

Special tools are necessary for certain tasks. The tools are not a component of the vehicle, but can be ordered using the number in parentheses. Example: bearing puller (15112017000)

Unless otherwise noted, normal conditions apply to all tasks and descriptions.

Ambient temperature	20 °C (68 °F)
Ambient air pressure	1,013 mbar (14.69 psi)
Relative air humidity	60 ± 5 %

During assembly, use new parts to replace parts which cannot be reused (e.g. self-locking screws and nuts, expansion screws, seals, sealing rings, O-rings, pins, and lock washers).

In the case of certain screws, a screw adhesive (e.g. **Loctite**®) is required. Observe the manufacturer's instructions.

If thread locker (e.g., **Precote**®) has already been applied to a new part, do not apply any additional thread locker. After disassembly, clean the parts that are to be reused and check them for damage and wear. Change damaged or worn parts.

After completing a repair or service work, check the operating safety of the vehicle.

2.9 Environment

If you use your motorcycle responsibly, you can ensure that problems and conflicts do not occur. To protect the future of the motorcycle sport, make sure that you use your motorcycle legally, display environmental consciousness, and respect the rights of others.

When disposing of used oil, other operating and auxiliary fluids, and used components, comply with the laws and regulations of the respective country.

Because motorcycles are not subject to the EU regulations governing the disposal of used vehicles, there are no legal regulations that pertain to the disposal of an end-of-life motorcycle. Your authorized KTM dealer will be glad to advise you.

2.10 Owner's Manual

Read this owner's manual carefully and completely before making your first trip. The Owner's Manual contains useful information and many tips on how to operate, handle, and service your motorcycle. This is the only way to find out how best to customize the vehicle for your own use and how you can protect yourself from injury.



Tip

Store the Owner's Manual on your terminal device, for example, so that you can read it whenever you need to.

If you would like to know more about the vehicle or have questions on the material you read, please contact an authorized KTM dealer.

The Owner's Manual is an important component of the vehicle. If the vehicle is sold, the Owner's Manual must be downloaded again by the new owner.

The Owner's Manual can be downloaded several times using the QR code or the link on the delivery certificate.

The Owner's Manual is also available for download from your authorized KTM dealer and on the KTM website. A printed copy can also be ordered from your authorized KTM dealer.

International KTM Website: KTM.COM

3.1 Manufacturer warranty, implied warranty

The work prescribed in the service schedule must only be carried out in an authorized KTM workshop and confirmed in the **KTM Dealer.net**, as otherwise all warranty claims will be void. Damage or secondary damage caused by tampering with and/or conversions on the vehicle are not covered by the manufacturer warranty.

3.2 Fuel, auxiliary substances



Note

Environmental hazard Improper handling of fuel is a danger to the environment.

- Do not allow fuel to enter the groundwater, the soil, or the sewage system.

Use fuels and auxiliary substances in accordance with the Owner's Manual and specification.

3.3 Spare parts, technical accessories

For your own safety, only use spare parts and accessory products that are approved and/or recommended by KTM and have them installed by an authorized KTM workshop. KTM accepts no liability for other products and any resulting damage or loss.

Certain spare parts and accessory products are specified in parentheses in the descriptions. Your authorized KTM dealer will be glad to advise you.

The latest news **KTM PowerParts** on your vehicle can be found on the KTM website.
International KTM Website: KTM.COM

3.4 Service

A prerequisite for perfect operation and prevention of premature wear is that the service, care, and tuning work on the engine and chassis is properly carried out as described in the Owner's Manual. An incorrect suspension setting can lead to damage and breakage of chassis components.

Use of the vehicle under difficult conditions, such as on sand or on wet, dusty and muddy surfaces, can result in significantly increased wear of components, such as the drive train, brake system, air filter or suspension components. For this reason, it may be necessary to inspect or replace parts before the next scheduled service.

It is imperative that you adhere to the stipulated run-in times and service intervals. If you observe these exactly, you will ensure a much longer service life for your motorcycle.

The relevant mileage or time interval is whichever occurs first.

3.5 Figures

The figures contained in the manual may depict special equipment.

In the interest of clarity, some components may be shown disassembled or may not be shown at all. It is not always necessary to disassemble the component to perform the activity in question. Please follow the instructions in the text.

3.6 Customer service

Your authorized KTM dealer will be happy to answer any questions you may have on your vehicle and KTM.

A list of authorized KTM dealers can be found on the KTM website.
International KTM Website: KTM.COM

4 VIEW OF VEHICLE

4.1 View of vehicle, front left (example)



- ❶ Clutch lever (📖 p. 16)
- ❷ Fuel tank filler cap
- ❸ Air filter box cover
- ❹ Side stand (📖 p. 22)
- ❺ Engine number (📖 p. 15)
- ❻ Shift lever (📖 p. 22)

4.2 View of vehicle, rear right (example)

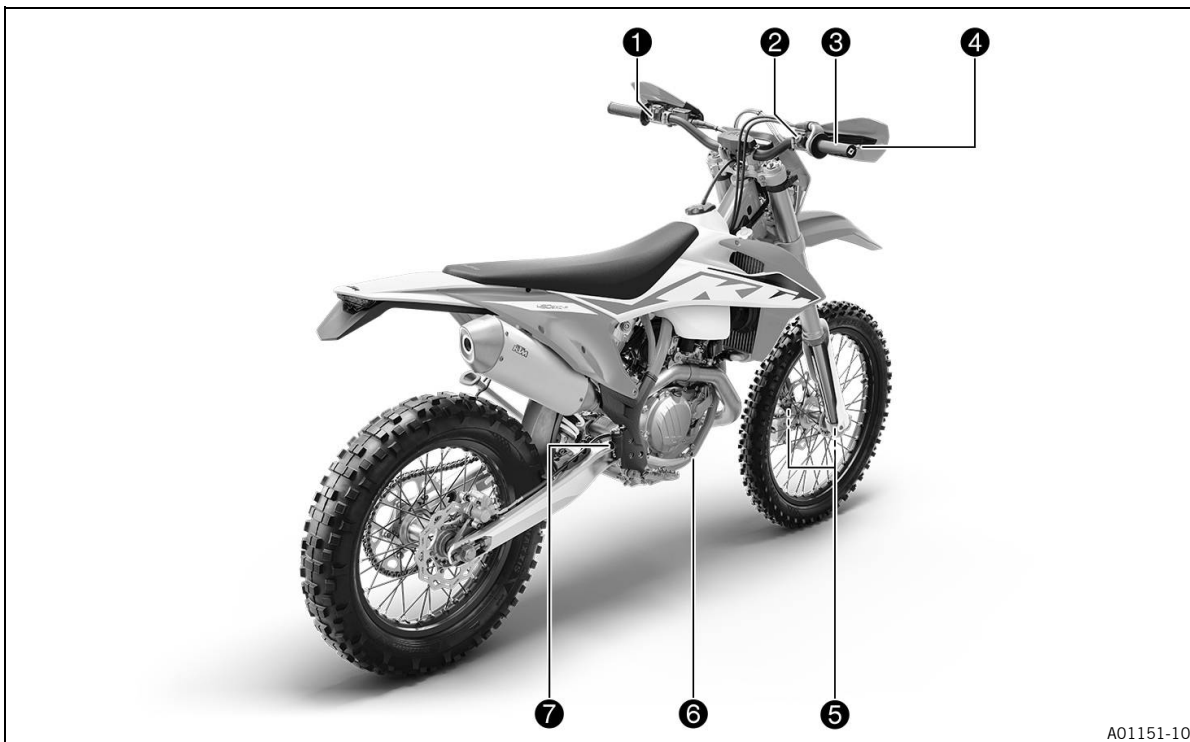

A01151-10

- ❶ Stop button (📖 p. 16)
- ❶ Horn button (📖 p. 17) **(All EU models)**
- ❶ Light switch (📖 p. 17) **(All EU models)**
- ❶ Turn signal switch (📖 p. 18) **(All EU models)**
- ❷ Start button (📖 p. 18)
- ❸ Throttle grip (📖 p. 16)
- ❹ Hand brake lever (📖 p. 16)
- ❺ Fork part number (📖 p. 15)
- ❻ Foot brake lever (📖 p. 22)
- ❼ Level viewer for brake fluid, rear

5.1 Vehicle identification number

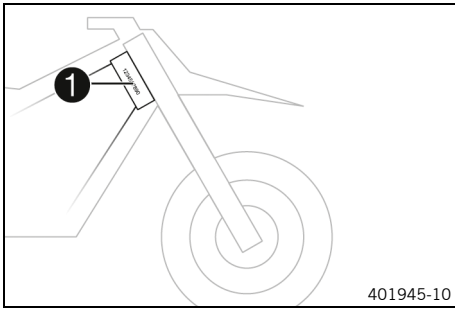

The vehicle identification number **1** is stamped on the right side of the steering head.

5.2 Type label

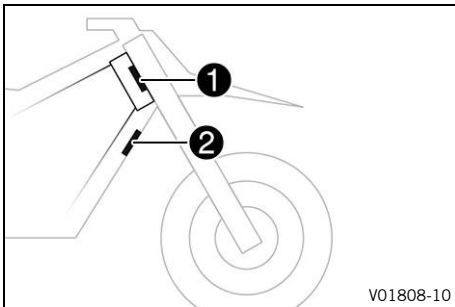

(All EU models)

The Europe type label **1** is fixed to the front of the steering head.

The Canada type label **2** is fixed to the front of the chest tube.

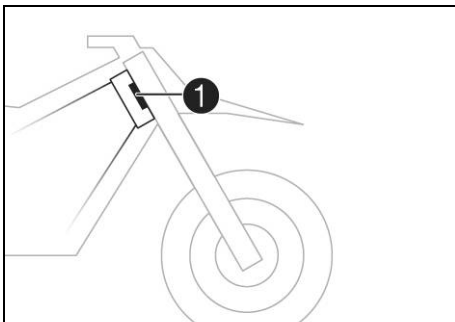

(XCF-W)

Type label **1** is fixed to the front of the steering head.

The additional type label for Canada **2** is fixed to the front of the chest tube.

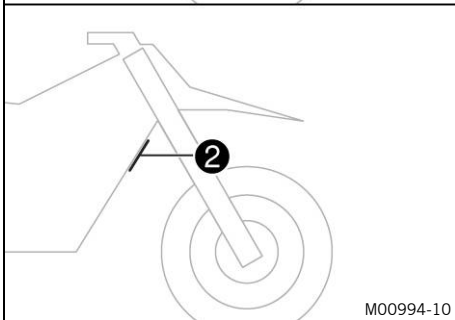

5.3 Key number (All EU models)

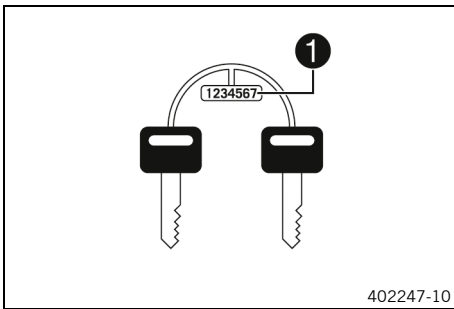

The key number ❶ for the steering lock is stamped onto the key connector.

5.4 Engine number

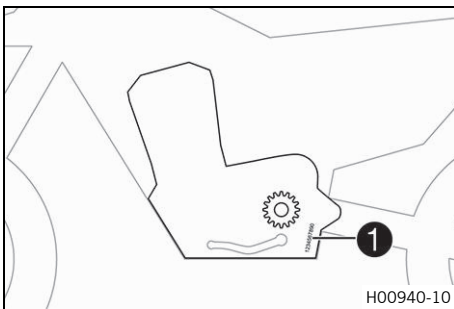

Engine number ❶ is embossed on the left side of the engine behind the shift lever.

5.5 Fork part number

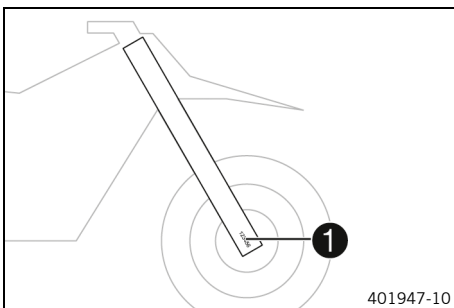

The fork part number ❶ is stamped on the inner side of the fork stub.

5.6 Shock absorber article number

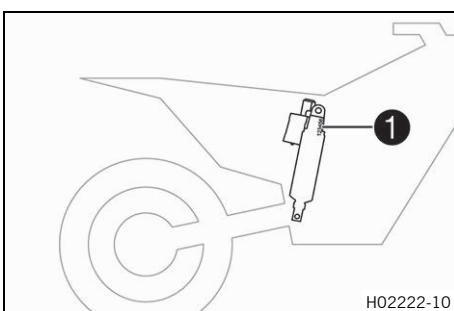

Shock absorber article number ❶ is stamped on the top of the shock absorber above the adjusting ring towards the engine side.

6.1 Clutch lever

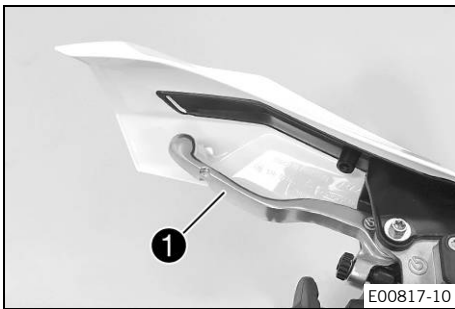

The clutch lever **1** is fitted on the left side of the handlebar. The clutch is hydraulically operated and self-adjusting.

6.2 Hand brake lever

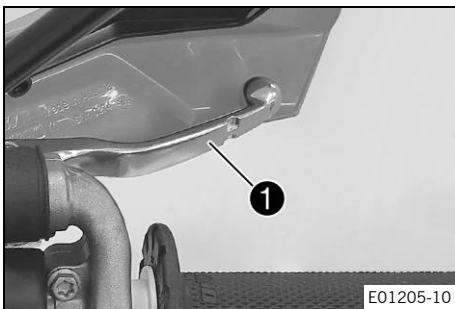

The hand brake lever **1** is fitted on the right side of the handlebar. The hand brake lever is used to activate the front brake.

6.3 Throttle grip

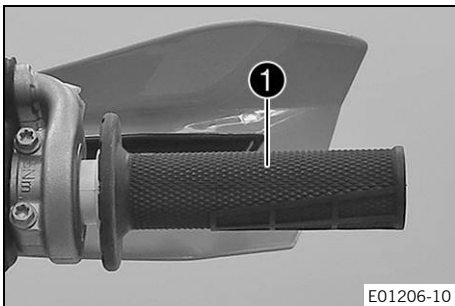

The throttle grip **1** is fitted on the right side of the handlebar.

6.4 Stop button



(All EU models)

The stop button **1** is fitted on the left side of the handlebar.

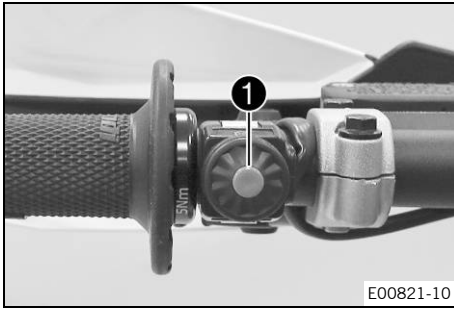

(XCF-W)

The stop button ① is fitted on the left side of the handlebar.

Possible states

- The stop button ☒ is in the basic position – In this position, the ignition circuit is closed and the engine can be started.
- Stop button ☒ pressed – In this position, the ignition circuit is interrupted, a running engine stops, and a non-running engine will not start.

6.5 Horn button (All EU models)



Horn button ① is fitted on the left side of the handlebar.

Possible states

- The horn button ☞ is in the basic position
- The horn button ☞ is pressed – The horn is operated in this position.

6.6 Light switch (All EU models)



The light switch ① is fitted on the left side of the handlebar.

Possible states

	Low beam on – Light switch is in the central position. In this position, the low beam and tail light are switched on.
	High beam on – The light switch is turned counter-clockwise. In this position, the high beam and the tail light are switched on.

6.7 Light switch (XCF-W)

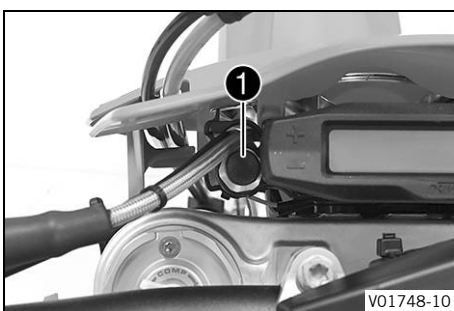

The light switch ① is located to the left of the combination instrument.

Possible states

- Light off – Light switch is pressed in up to the stop. In this position, the light is switched off.
- Light on – Light switch is pulled out to the stop. In this position, the low beam and the tail light are switched on.

6.8 Turn signal switch (All EU models)



The turn signal switch **1** is fitted on the left side of the handlebar.

Possible states

	Turn signal off – Turn signal switch is in the central position.
←	Turn signal, left, on – The turn signal switch is turned to the left.
→	Turn signal, right, on – The turn signal switch is turned to the right.

6.9 Emergency OFF switch



(All EU models)

The emergency OFF switch **1** is fitted on the right side of the handlebar.

Possible states

	Ignition off – In this position, the ignition circuit is interrupted, a running engine stops, and a non-running engine will not start.
	Ignition on – In this position, the ignition circuit is closed and the engine can be started.

6.10 Start button



(All EU models)

Start button **1** is fitted on the right side of the handlebar.

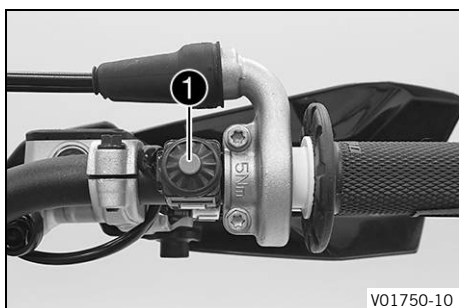

(XCF-W)

Start button **1** is fitted on the right side of the handlebar.

Possible states

- The start button is in the basic position
- The start button is pressed – The starter motor is actuated in this position.

6.11 Combination switch (EXC-F SIX DAYS, XCF-W)

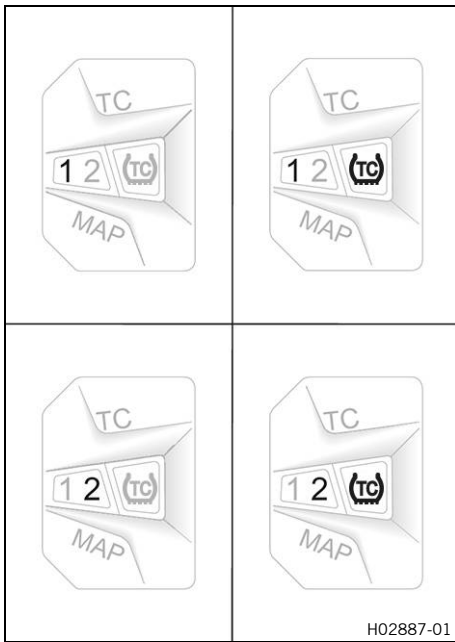

The combination switch is fitted on the left side of the handlebar.

Possible states

1	STANDARD – STANDARD mapping is activated when LED 1 lights up.
1TC	STANDARD with TC – STANDARD mapping with traction control is activated when LED 1 and TC light up.
2	ADVANCED – ADVANCED mapping is activated, when LED 2 lights up.
2TC	ADVANCED with TC – ADVANCED mapping with traction control is activated when LED 2 and TC light up.



Warning

Voiding of the government approval for road use and the insurance coverage If the combination switch is mounted, the vehicle's road permit, if any, expires.

- Only operate the vehicle in closed-off areas remote from public road traffic if the combination switch is installed.

The engine characteristic can be changed using button **MAP** on the combination switch.

The traction control can also be activated via the combination switch.

6.12 Overview of indicator lamps (All EU models)



Possible states

	The high beam indicator lamp lights up blue – The high beam is switched on.
	Malfunction indicator lamp lights up/flashes yellow – The OBD has detected an error in the vehicle electronics. Come safely to a halt, and contact an authorized KTM workshop.
	The fuel level warning lamp lights up yellow – The fuel level has reached the reserve mark.
	Turn signal indicator lamp flashes green – The turn signal is switched on.

6.13 Overview of indicator lamps (XCF-W)



Possible states

	Malfunction indicator lamp lights up/flashes yellow – The OBD has detected an error in the vehicle electronics. Stop and contact an authorized KTM workshop.
	The fuel level warning lamp lights up yellow – The fuel level has reached the reserve mark.

6.14 Opening fuel tank filler cap



Danger

Fire hazard Fuel is highly flammable.

The fuel in the fuel tank expands when warm and can escape if overfilled.

- Do not fuel the vehicle in the vicinity of open flames or lit cigarettes.
- Switch off the engine for refueling.
- Make sure that no fuel is spilled; particularly not on hot parts of the vehicle.
- If any fuel is spilled, wipe it off immediately.
- Observe the specifications for refueling.



Warning

Danger of poisoning Fuel is poisonous and a health hazard.

- Avoid skin, eye and clothing contact with fuel.
- Immediately consult a doctor if you swallow fuel.
- Do not inhale fuel vapors.
- In case of skin contact, rinse the affected area with plenty of water.
- Rinse the eyes thoroughly with water, and consult a doctor in case of fuel contact with the eyes.
- Change your clothing in case of fuel spills on them.
- Keep fuels correctly in a suitable canister, and out of the reach of children.



Note

Environmental hazard Improper handling of fuel is a danger to the environment.

- Do not allow fuel to enter the groundwater, the soil, or the sewage system.

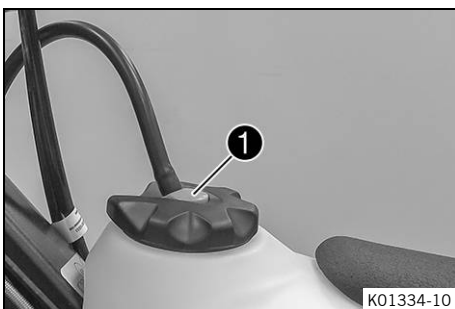

- Press release button **1**, turn the fuel tank filler cap counter-clockwise, and lift it off.

6.15 Closing the fuel tank filler cap

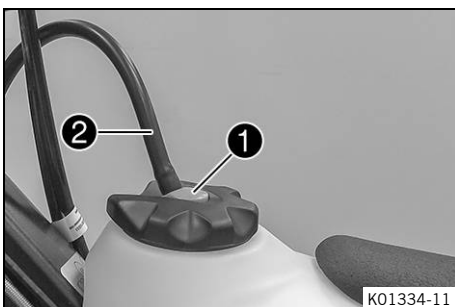

- Mount fuel tank filler cap and turn it clockwise until the release button **1** engages.



Info

Route fuel tank breather hose **2** without kinks.

6.16 Cold start button

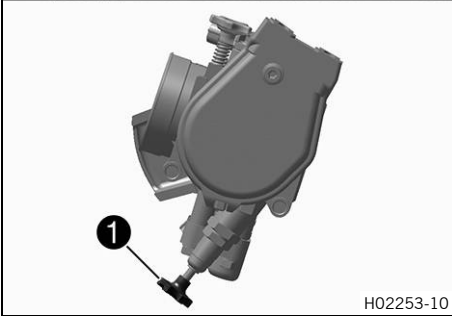
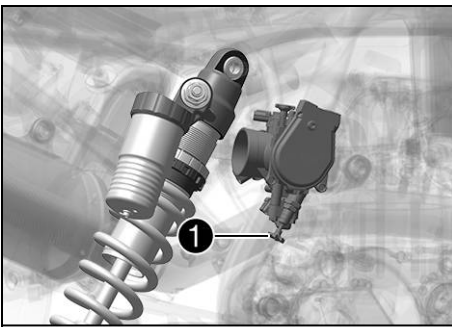

H02253-10

The cold start button **1** is fitted to the bottom of the throttle valve body.

The electronic fuel injection system extends the injection time if the engine is cold and the ambient temperature is low. To help the engine burn the increased fuel quantity, it must be supplied with additional oxygen by pushing the cold start button.

After briefly opening up the throttle and then releasing the throttle grip again, or turning the throttle grip towards the front, the cold start button returns to its original position.



Info

Check whether the cold start button has returned to its basic position.

Possible states

- The cold start button is activated – The cold start button is pushed in all the way.
- The cold start button is deactivated – The cold start button is in its basic position.

6.17 Idle speed adjusting screw

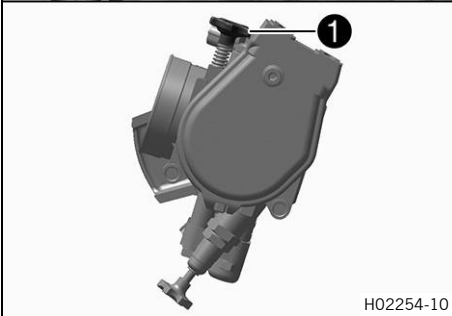
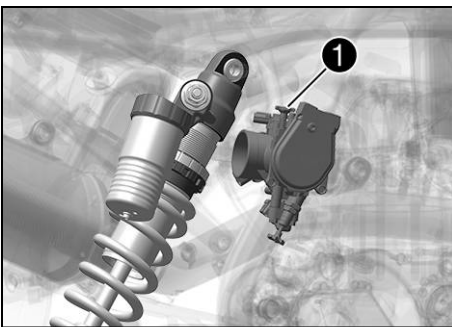

H02254-10

The idle setting of the throttle valve body substantially influences the vehicle's starting behavior, a stable idle speed, and the vehicle's response when the throttle is opened.

An engine with a correctly set idle speed is easier to start than an engine with the idle speed set incorrectly.

The idle speed is adjusted using the idle speed adjusting screw **1**.

Increase the idle speed by turning the idle speed adjusting screw clockwise.

Decrease the idle speed by turning the idle speed adjusting screw counterclockwise.

6.18 Shift lever

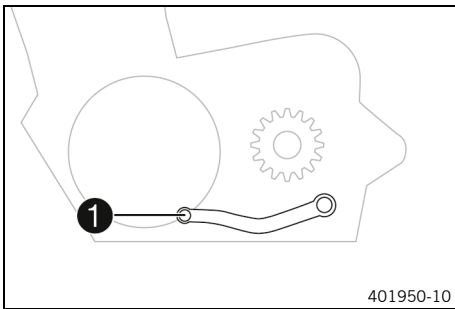

Shift lever ❶ is mounted on the left of the engine.

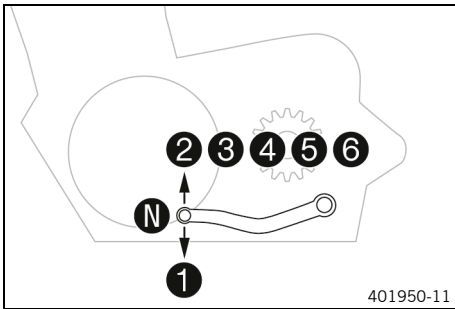

The gear positions can be seen in the figure.
The neutral or idle position is between the first and second gears.

6.19 Foot brake lever

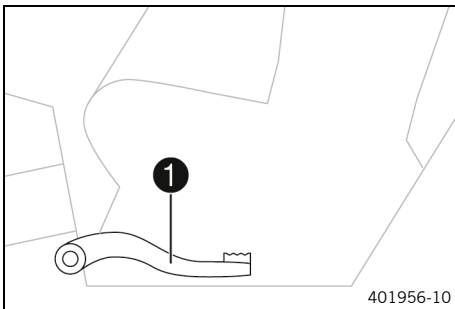

Foot brake lever ❶ is located in front of the right footrest.
The rear brake is engaged with the foot brake lever.

6.20 Side stand

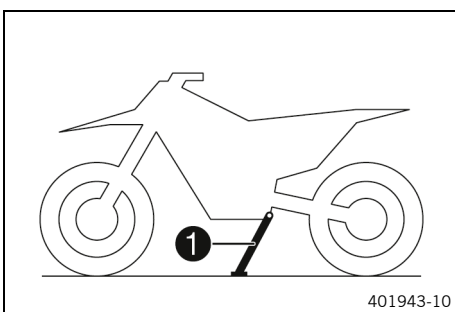

The side stand ❶ is attached to the left side of the vehicle.

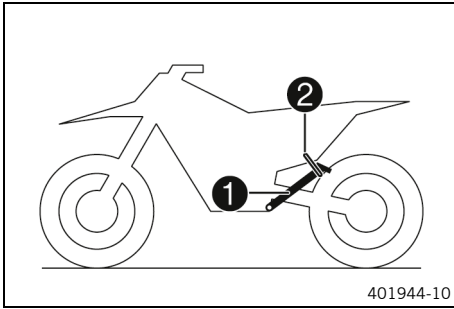

The side stand is used for parking the motorcycle.

i Info
When you are riding, side stand ① must be folded up and secured with rubber strap ②.

6.21 Steering lock (All EU models)

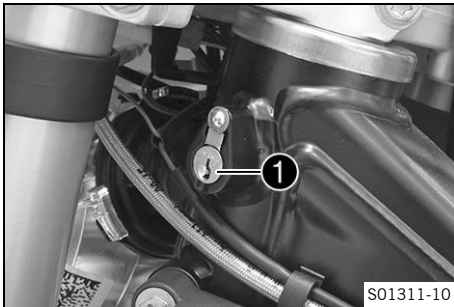

Steering lock ① is fitted on the left side of the steering head. The steering lock is used to lock the steering. Steering, and therefore riding, is no longer possible.

6.22 Locking the steering (All EU models)

Note

Danger of damage The parked vehicle can roll away or fall over.

- Park the vehicle on a firm and level surface.

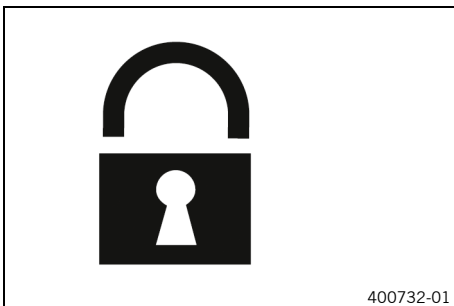

- Park the vehicle.
- Turn handlebar as far as possible to the right.
- Lubricate the steering lock regularly.

Universal oil spray (📖 p. 167)

- Insert the key for the steering lock into the steering lock (📖 p. 23), turn it to the left, push it in, and turn it to the right. Pull out the key for the steering lock.
- ✓ Steering is no longer possible.

i Info
Never leave the key for the steering lock in the steering lock.

6.23 Unlocking the steering (All EU models)

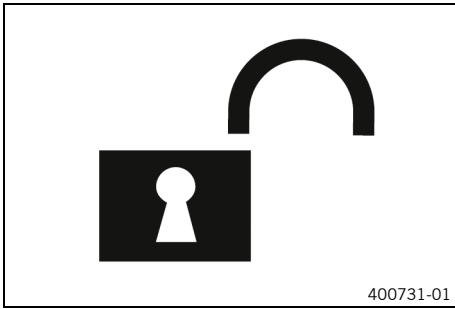

- Insert the key for the steering lock into the steering lock (📖 p. 23), turn it to the left, pull it out, and turn it to the right. Pull out the key for the steering lock.
 - ✓ The handlebar can now be moved again.



Info

Never leave the key for the steering lock in the steering lock.

7.1 Combination instrument overview

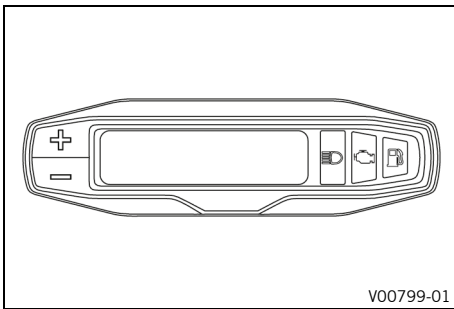

- Press the button to control different functions.
- Press the button to control different functions.



Info

When the vehicle is delivered, only the **SPEED/H** and **SPEED/ODO** display modes are activated.

7.2 Activation and test

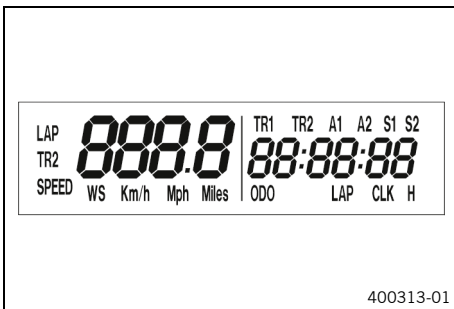

Activating combination instrument

The combination instrument is activated when one of the buttons is pressed or an impulse comes from the wheel speed sensor.

Display test

To enable you to check that the display is functioning properly, all display segments light up briefly.

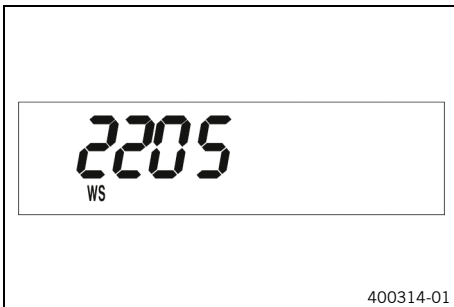

WS (wheel size)

After the display function check, the wheel circumference **WS** is displayed briefly.



Info

The number 2205 equals the circumference of the 21" front wheel with standard tires.

The display then changes to the last selected mode.

7.3 Setting kilometers or miles



Info

If you change the unit, the value **ODO** is retained and converted accordingly. The values **TR1**, **TR2**, **A1**, **A2** and **S1** are cleared when the unit of measure is changed.

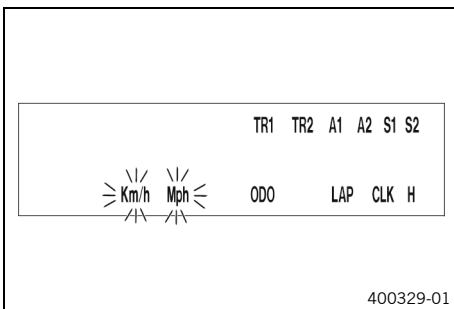

Condition

The motorcycle is stationary.

- Repeatedly press the button briefly until **H** appears at the bottom right of the display.
- Press the button for 2–3 seconds.
 - ✓ The Setup menu is displayed and the active functions are shown.
- Repeatedly press the button briefly until **Km/h/Mph** flashes.

Adjusting the Km/h

- Press the button .

Adjusting the Mph

- Press the button .

- Wait 3 - 5 seconds.
- ✓ The settings are stored.



Info

If no button is pressed for 10–12 seconds, or if an impulse comes from the wheel speed sensor, the settings are automatically saved and the setup menu is closed.

7.4 Setting the combination instrument



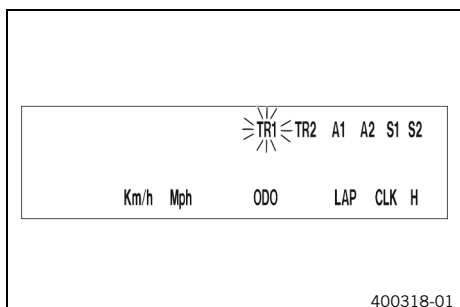

Info

When the vehicle is delivered, only the **SPEED/H** and **SPEED/ODO** display modes are activated.



Condition

The motorcycle is stationary.

- Repeatedly press the button  briefly until **H** appears at the bottom right of the display.
- Press the button  for 2–3 seconds.
- ✓ The Setup menu is displayed and the active functions are shown.



Info

If no button is pressed for 10–12 seconds, the settings are automatically saved.

If no button is pressed for 20 seconds, or if an impulse comes from the wheel speed sensor, the settings are automatically saved and the setup menu is closed.

- Repeatedly press the button  briefly until the desired function flashes.
- ✓ The selected function flashes.

Activating the function

- Press the button .
- ✓ The symbol continues to appear in the display and the next function appears.

Deactivating a function

- Press the button .
- ✓ The symbol disappears in the display and the next function appears.

7.5 Setting the clock

Condition

The motorcycle is stationary.

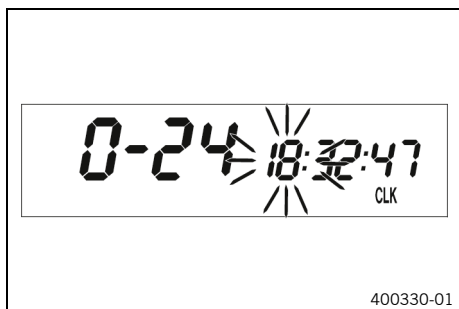

- Repeatedly press the button **+** briefly until **CLK** appears at the bottom right of the display.
- Press the button **+** for 2–3 seconds.
 - ✓ The hour display flashes.
- Adjust the hour display with the button **+** and/or button **-**.
- Wait 3 - 5 seconds.
 - ✓ The next segment of the display flashes and can be set.
- You can set the following segments in the same way as the hours by pressing the button **+** and the button **-**.

**Info**

The seconds can only be set to zero.

If no button is pressed for 15–20 seconds, or if an impulse comes from the wheel speed sensor, the settings are automatically saved and the setup menu is closed.

7.6 Viewing the lap time

**Info**

This function can only be opened if lap times have actually been timed.

Condition

The motorcycle is stationary.

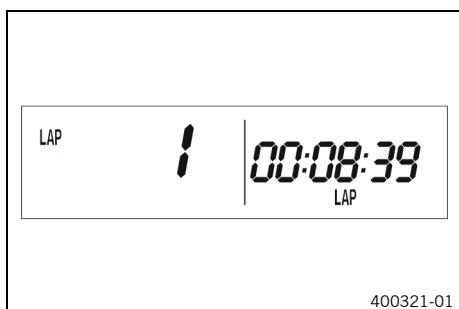

- Repeatedly press the button **+** briefly until **LAP** appears at the bottom right of the display.
- Briefly press the button **+**.
 - ✓ **LAP 1** appears on the left side of the display.
- The laps 1–10 can be viewed with the button **-**.
- Press and hold the button **+** for 3-5 seconds.
 - ✓ The lap times are deleted.
- Briefly press the button **+**.
 - ✓ Next display mode

**Info**

When an impulse is received from the wheel speed sensor, the left side of the display changes back to the **SPEED** mode.

7.7 Display mode SPEED (speed)



- Repeatedly press the button **+** briefly until **SPEED** appears on the left side of the display.

The current speed is displayed in the **SPEED** display mode.

The current speed can be displayed in **Km/h** or **Mph**.



Info

Make the setting according to the country.

When an impulse comes from the front wheel, the left side of the display changes to the **SPEED** mode and the current speed is shown.

7.8 Display mode SPEED/H (operating hours)



Condition

- The motorcycle is stationary.
- Repeatedly press the button **+** briefly until **H** appears at the bottom right of the display.

In display mode **H**, the operating hours of the engine are displayed.

The operating hour counter stores the total traveling time.



Info

The operating hour counter is necessary for ensuring that service work is carried out at the right intervals.

If the combination instrument is in **H** display mode when starting off, it automatically changes to the **ODO** display mode.

The **H** display mode is suppressed during the journey.

Press the button + for 2–3 seconds.	The display changes to the functions setup menu.
Briefly press the button + .	Next display mode
Press the button - for 2–3 seconds.	No function
Briefly press the button - .	No function

7.9 Setup menu

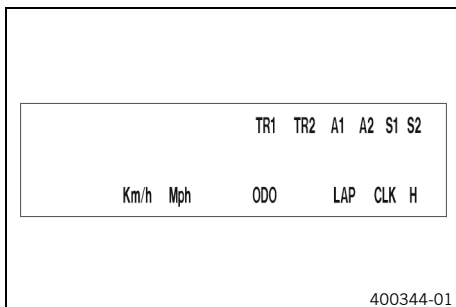

Condition

- The motorcycle is stationary.
- Repeatedly press the button **+** briefly until **H** appears at the bottom right of the display.
- Press the button **+** for 2–3 seconds.

The Setup menu displays the active functions.

i Info

Repeatedly press the button **+** briefly until the desired function is reached.
If no button is pressed for 20 seconds, the settings are automatically saved.

Briefly press the button + .	Activates the flashing display and changes to the next display
Press the button + for 2–3 seconds.	No function
Briefly press the button - .	Deactivates the flashing display and changes to the next display
Press the button - for 2–3 seconds.	No function
Wait 3 - 5 seconds.	Changes to the next display without changes
Wait 10 - 12 seconds.	Setup menu starts, stores the settings, and changes to H or ODO .

7.10 Adjusting the unit of measurement

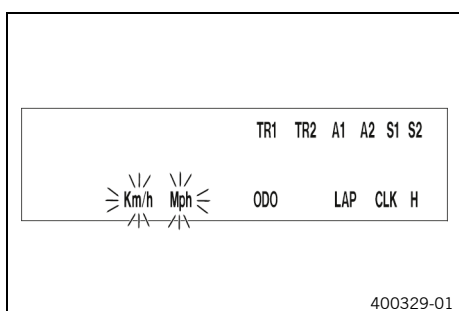

Condition

- The motorcycle is stationary.
 - Repeatedly press the button **+** briefly until **H** appears at the bottom right of the display.
 - Press the button **+** for 2–3 seconds.
 - Repeatedly press the button **+** briefly until **Km/h/Mph** flashes.
- In measurement unit mode, you can change the unit of measurement.

i Info

If no button is pressed for 5 seconds, the settings are automatically saved.



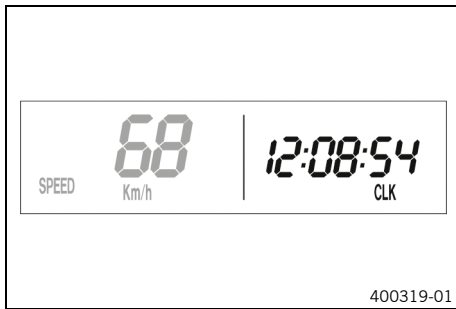

Briefly press the button + .	Starts selection, activates Km/h display
Press the button + for 2–3 seconds.	No function
Briefly press the button - .	Activates Mph display
Press the button - for 2–3 seconds.	No function
Wait 3 - 5 seconds.	Changes to the next display, changes from selection to the Setup menu
Wait 10 - 12 seconds.	Stores and closes the Setup menu

7.11 Display mode SPEED/CLK (time)



- Repeatedly press the button  briefly until **CLK** appears at the bottom right of the display.



The time is shown in display mode **CLK**.





Press the button  for 2–3 seconds.	The display changes to the Setup menu of the clock.
Briefly press the button  .	Next display mode
Press the button  for 2–3 seconds.	No function
Briefly press the button  .	No function

7.12 Setting the clock



Condition

- The motorcycle is stationary.
- Repeatedly press the button  briefly until **CLK** appears at the bottom right of the display.
- Press the button  for 2–3 seconds.



Press the button  for 2–3 seconds.	Increases the value
Briefly press the button  .	Increases the value
Press the button  for 2–3 seconds.	Reduces the value
Briefly press the button  .	Reduces the value
Wait 3 - 5 seconds.	Changes to the next value
Wait 10 - 12 seconds.	Exit the Setup menu

7.13 Display mode SPEED/LAP (lap time)





- Repeatedly press the button  briefly until **LAP** appears at the bottom right of the display.

In the **LAP** display mode, up to 10 lap times can be timed with the stop watch.

i Info
If the lap time continues running after the button  is pressed, 9 memory locations are occupied. Lap 10 must be timed using the button .



Press the button  for 2–3 seconds.	The stop watch and the lap time are reset.
---	--



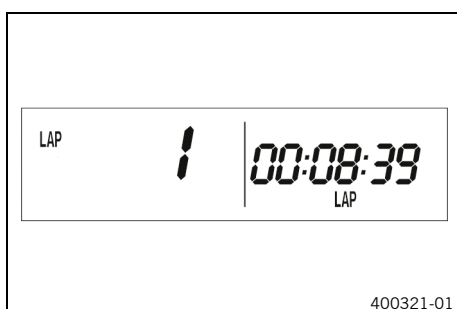

Briefly press the button  .	Next display mode
Press the button  for 2–3 seconds.	Stops the clock.
Briefly press the button  .	Starts the stop watch or stop the current lap time measurement, stores it and the stop watch starts the next lap.

7.14 Viewing the lap time



Condition

- The motorcycle is stationary.
- Repeatedly press the button  briefly until **LAP** appears at the bottom right of the display.
- Briefly press the button .





Press the button  for 2–3 seconds.	The stop watch and the lap time are reset.
Briefly press the button  .	Select a lap from 1–10
Press the button  for 2–3 seconds.	No function
Briefly press the button  .	View the next lap time.

7.15 Display mode SPEED/ODO (odometer)



- Repeatedly press the button  briefly until **ODO** appears at the bottom right of the display.

The total traveled distance is shown in display mode **ODO**.

Press the button  for 2–3 seconds.	No function
Briefly press the button  .	Next display mode
Press the button  for 2–3 seconds.	No function
Briefly press the button  .	No function

7.16 Display mode SPEED/TR1 (trip master 1)

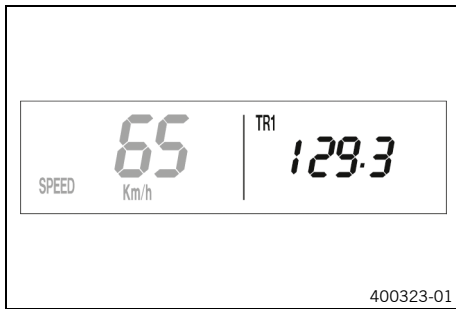

- Repeatedly press the button briefly until **TR1** appears at the top right of the display.

TR1 (trip master 1) runs constantly and counts up to 999.9. You can use it to measure trips or the distance between refueling stops.

TR1 is coupled with **A1** (average speed 1) and **S1** (stop watch 1).

Info
If 999.9 is exceeded, the values of **TR1**, **A1** and **S1** are automatically reset to 0.0.

Press the button for 2–3 seconds.	Displays of TR1 , A1 and S1 are reset to 0,0.
Briefly press the button .	Next display mode
Press the button for 2–3 seconds.	No function
Briefly press the button .	No function

7.17 Display mode SPEED/TR2 (trip master 2)

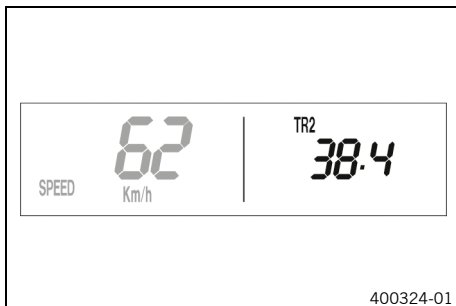

- Repeatedly press the button briefly until **TR2** appears at the top right of the display.

TR2 (trip master 2) runs constantly and counts up to 999.9.

Press the button for 2–3 seconds.	Clears the values TR2 and A2 .
Briefly press the button .	Next display mode
Press the button for 2–3 seconds.	Reduces value of TR2 .
Briefly press the button .	Reduces value of TR2 .

7.18 Adjusting TR2 (trip master 2)

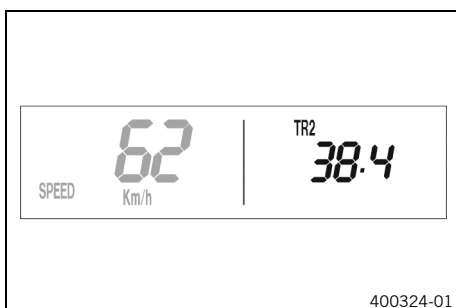

Condition

- The motorcycle is stationary.
- Repeatedly press the button briefly until **TR2** appears at the top right of the display.
- Press the button for 2–3 seconds until **TR2** flashes.

The displayed value can be set manually with the button and the button . This is a very practical function when riding using the road book.

i Info

The **TR2** value can also be corrected manually during the journey with the button **+** and the button **-**.
If 999.9 is exceeded, the value of **TR2** is automatically reset to 0.0.

Press the button + for 2–3 seconds.	Increases value of TR2 .
Briefly press the button + .	Increases value of TR2 .
Press the button - for 2–3 seconds.	Reduces value of TR2 .
Briefly press the button - .	Reduces value of TR2 .
Wait 10 - 12 seconds.	Stores and closes the Setup menu.

7.19 Display mode SPEED/A1 (average speed 1)



- Repeatedly press the button **+** briefly until **A1** appears at the top right of the display.

A1 (average speed 1) shows the average speed calculated using **TR1** (trip master 1) and **S1** (stop watch 1).

The calculation of this value is activated by the first impulse of the wheel speed sensor and ends 3 seconds after the last impulse.

Press the button + for 2–3 seconds.	Displays of TR1 , A1 and S1 are reset to 0.0.
Briefly press the button + .	Next display mode
Press the button - for 2–3 seconds.	No function
Briefly press the button - .	No function

7.20 Display mode SPEED/A2 (average speed 2)



- Repeatedly press the button **+** briefly until **A2** appears at the top right of the display.



A2 (average speed 2) shows the average speed on the basis of the current speed if the stop watch **S2** (stop watch 2) is running.

i Info

The displayed value can differ from the actual average speed if **S2** was not stopped after the ride.

Briefly press the button + .	Next display mode
Press the button + for 2–3 seconds.	No function

7 COMBINATION INSTRUMENT

Press the button  for 2–3 seconds.	No function
Briefly press the button  .	No function





7.21 Display mode SPEED/S1 (stop watch 1)



- Repeatedly press the button  briefly until **S1** appears at the top right of the display.

S1 (Stop watch 1) shows the riding time based on **TR1** and continues running as soon as an impulse arrives from the wheel speed sensor.

The calculation of this value starts with the first impulse from the wheel speed sensor and ends 3 seconds after the last impulse.

Press the button  for 2–3 seconds.	Displays of TR1 , A1 and S1 are reset to 0.0.
Briefly press the button  .	Next display mode
Press the button  for 2–3 seconds.	No function
Briefly press the button  .	No function





7.22 Display mode SPEED/S2 (stop watch 2)







- Repeatedly press the button  briefly until **S2** appears at the top right of the display.

S2 (Stop watch 2) is a manual stop watch.

If **S2** is running in the background, the display **S2** flashes.

Press the button  for 2–3 seconds.	The displays of S2 and A2 are set to 0,0.
Briefly press the button  .	Next display mode
Press the button  for 2–3 seconds.	No function
Briefly press the button  .	Starts or stops S2 .

7.23 Table of functions

Display	Press the button  for 2–3 seconds.	Briefly press the button  .	Press the button  for 2–3 seconds.	Briefly press the button  .	Wait 3 - 5 seconds.	Wait 10 - 12 seconds.
Display mode SPEED/H (operating hours)	The display changes to the functions setup menu.	Next display mode	No function	No function		

Display	Press the button ⊞ for 2–3 seconds.	Briefly press the button ⊞ .	Press the button ⊞ for 2–3 seconds.	Briefly press the button ⊞ .	Wait 3 - 5 seconds.	Wait 10 - 12 seconds.
Setup menu	No function	Activates the flashing display and changes to the next display	No function	Deactivates the flashing display and changes to the next display	Changes to the next display without changes	Setup menu starts, stores the settings, and changes to H or ODO .
Adjusting the unit of measurement	No function	Starts selection, activates Km/h display	No function	Activates Mph display	Changes to the next display, changes from selection to the Setup menu	Stores and closes the Setup menu
Display mode SPEED/CLK (time)	The display changes to the Setup menu of the clock.	Next display mode	No function	No function		
Setting the clock	Increases the value	Increases the value	Reduces the value	Reduces the value	Changes to the next value	Exit the Setup menu
Display mode SPEED/LAP (lap time)	The stop watch and the lap time are reset.	Next display mode	Stops the clock.	Starts the stop watch or stop the current lap time measurement, stores it and the stop watch starts the next lap.		
Viewing the lap time	The stop watch and the lap time are reset.	Select a lap from 1–10	No function	View the next lap time.		
Display mode SPEED/ODO (odometer)	No function	Next display mode	No function	No function		
Display mode SPEED/TR1 (trip master 1)	Displays of TR1 , A1 and S1 are reset to 0,0.	Next display mode	No function	No function		
Display mode SPEED/TR2 (trip master 2)	Clears the values TR2 and A2 .	Next display mode	Reduces value of TR2 .	Reduces value of TR2 .		
Adjusting TR2 (trip master 2)	Increases value of TR2 .	Increases value of TR2 .	Reduces value of TR2 .	Reduces value of TR2 .		Stores and closes the Setup menu.
Display mode SPEED/A1 (average speed 1)	Displays of TR1 , A1 and S1 are reset to 0.0.	Next display mode	No function	No function		
Display mode SPEED/A2 (average speed 2)	No function	Next display mode	No function	No function		

7 COMBINATION INSTRUMENT

Display	Press the button \oplus for 2–3 seconds.	Briefly press the button \oplus .	Press the button \ominus for 2–3 seconds.	Briefly press the button \ominus .	Wait 3 - 5 seconds.	Wait 10 - 12 seconds.
Display mode SPEED/S1 (stop watch 1)	Displays of TR1 , A1 and S1 are reset to 0.0.	Next display mode	No function	No function		
Display mode SPEED/S2 (stop watch 2)	The displays of S2 and A2 are set to 0,0.	Next display mode	No function	Starts or stops S2 .		

7.24 Table of conditions and menu activation

Display	The motorcycle is stationary.	Menu can be activated
Display mode SPEED/H (operating hours)	•	
Setup menu	•	
Adjusting the unit of measurement	•	
Setting the clock	•	
Display mode SPEED/LAP (lap time)		•
Viewing the lap time	•	
Display mode SPEED/TR1 (trip master 1)		•
Display mode SPEED/TR2 (trip master 2)		•
Adjusting TR2 (trip master 2)	•	
Display mode SPEED/A1 (average speed 1)		•
Display mode SPEED/A2 (average speed 2)		•
Display mode SPEED/S1 (stop watch 1)		•
Display mode SPEED/S2 (stop watch 2)		•

8.1 Advice on preparing for first use

 **Danger**
Danger of accidents A rider who is not fit to ride poses a danger to him or herself and others.

- Do not operate the vehicle if you are not fit to ride due to alcohol, drugs or medication.
- Do not operate the vehicle if you are physically or mentally impaired.

 **Warning**
Risk of injury Missing or poor protective clothing presents an increased safety risk.

- Wear appropriate protective clothing such as helmet, boots, gloves as well as trousers and a jacket with protectors on all rides.
- Always wear protective clothing that is in good condition and meets the legal regulations.

 **Warning**
Danger of crashing Different tire tread patterns on the front and rear wheel impair the handling characteristic.

Different tire tread patterns can make the vehicle significantly more difficult to control.

- Make sure that only tires with a similar tire tread pattern are fitted to the front and rear wheel.

 **Warning**
Danger of accidents An unadapted riding style impairs the handling characteristic.

- Adapt your riding speed to the road conditions and your riding ability.

 **Warning**
Danger of accidents The vehicle is not designed to carry passengers.

- Do not ride with a passenger.

 **Warning**
Danger of accidents The brake system fails in the event of overheating.

If the foot brake lever is not released, the brake linings drag continuously.

- Take your foot off the foot brake lever if you do not want to brake.

 **Warning**
Danger of accidents Total weight and axle loads influence the handling characteristic.

- Do not exceed the maximum permissible overall weight or the axle loads.

 **Warning**
Risk of injury People who act without authorization may not be familiar with the vehicle.

- Do not leave the vehicle unattended if the engine is running.
- Protect the vehicle against access by unauthorized persons.

 **Info**
 When using your motorcycle, remember that others may feel disturbed by excessive noise.

- Make sure that the pre-sales inspection work has been carried out by an authorized KTM workshop.
 - ✓ You will receive a delivery certificate when the vehicle is handed over.
- Before riding for the first time, read the entire Owner's Manual carefully.
- Get to know the controls.
- Adjust basic position of the clutch lever. (📖 p. 95)
- Adjust basic position of the hand brake lever. (📖 p. 99)

8 PREPARING FOR USE

- Adjust the basic position of the foot brake lever. 📖 (p. 107)
- Adjust the basic position of the shift lever. 📖 (p. 141)
- Get used to the handling characteristics of the motorcycle on a suitable surface before undertaking more challenging trips.



Info

When offroad, it is recommended that you are accompanied by another person on another vehicle so that you can help each other.

- Try also to ride as slowly as possible and in a standing position to get a better feel for the motorcycle.
- Do not make any off-road trips that exceed your ability and experience.
- Hold the handlebar firmly with both hands and keep your feet on the footrests when riding.
- If you carry any luggage, make sure you fix it firmly as close as possible to the center of the vehicle and ensure even weight distribution between the front and rear wheels.



Info

Motorcycles react sensitively to any changes of weight distribution.

- Do not exceed the maximum permissible weight and maximum permissible axle loads.

Guideline

Maximum permissible overall weight	335 kg (739 lb.)
Maximum permissible front axle load	145 kg (320 lb.)
Maximum permissible rear axle load	190 kg (419 lb.)

- Check the spoke tension. 📖 (p. 118)



Info

The spoke tension must be checked after half an hour of operation.

- Run in the engine. 📖 (p. 38)

8.2 Running-in the engine

- During the running-in phase, do not exceed the specified engine speed and engine performance.

Guideline

Maximum engine speed	
During the first operating hour	7,000 rpm
Maximum engine performance	
During the first 3 operating hours	≤ 75 %

- Avoid fully opening the throttle!

8.3 Starting power of lithium-ion batteries at low temperatures

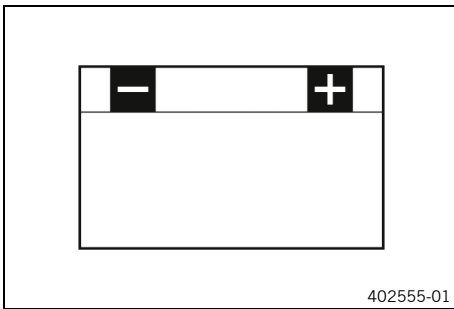

Lithium-ion batteries are far lighter than lead batteries, have a low self-discharge rate, and have more starting power at temperatures over 15 °C (60 °F). At low temperatures, however, the starting power of lithium-ion batteries drops to below that of lead batteries.

Multiple starting attempts may be needed. Press the start button for 5 seconds, and wait 30 seconds between attempts. The pauses are necessary so that the heat created can distribute through the lithium-ion battery and the lithium-ion battery is not damaged.

If the charged lithium-ion battery is unable to actuate the starter motor or does so only weakly when temperatures are below 15 °C (60 °F), the battery is not faulty but needs to be warmed up internally to increase its starting power (current output).

The starting power increases as the battery warms up.

8.4 Preparing the vehicle for difficult operating conditions

i Info

Use of the vehicle under difficult conditions, such as on sand or on wet and muddy surfaces, can result in significantly increased wear of components, such as the drive train, brake system, or suspension components. For this reason, it may be necessary to inspect or replace parts before the next scheduled service.

- Clean the air filter and air filter box. 📖 (p. 80)

i Info

Check the air filter approx. every 30 minutes.

- Check the connector for humidity and corrosion and to ensure it is firmly seated.
 - » If humidity, corrosion, or damage is found:
 - Clean and dry the connector, or change it if necessary.

Difficult operating conditions are:

- Rides on dry sand. 📖 (p. 39)
- Rides on wet sand. 📖 (p. 40)
- Rides on wet and muddy circuits. 📖 (p. 41)
- Rides at high temperatures or slow riding. 📖 (p. 41)
- Riding at low temperatures and in snow. 📖 (p. 42)



8.5 Preparing the vehicle for riding on dry sand



- Mount the air filter dust cover.

Air filter dust cover (79006920000)

i Info

Observe the fitting instructions for **KTM PowerParts**.

8 PREPARING FOR USE



102138-01

- Mount the air filter sand cover.

Air filter sand cover (79006922000)



Info

Observe the fitting instructions for **KTM PowerParts**.



600868-01

- Clean the chain.

Chain cleaner (📖 p. 166)

- Mount the steel sprocket.

- Grease the chain.

Universal oil spray (📖 p. 167)

- Clean the radiator fins.

- Straighten the bent radiator fins carefully.

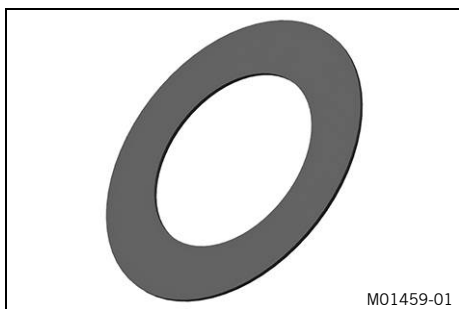

M01459-01

(All 450 models)

- Change the clutch spring. 🛠️

Clutch spring, hard (78932005000)

8.6 Preparing the vehicle for riding on wet sand



102137-01

- Mount the air filter rain cover.

Air filter rain cover (79006921000)



Info

Observe the fitting instructions for **KTM PowerParts**.



600868-01

- Clean the chain.

Chain cleaner (📖 p. 166)

- Mount the steel sprocket.

- Grease the chain.

Universal oil spray (📖 p. 167)

- Clean the radiator fins.

- Straighten the bent radiator fins carefully.

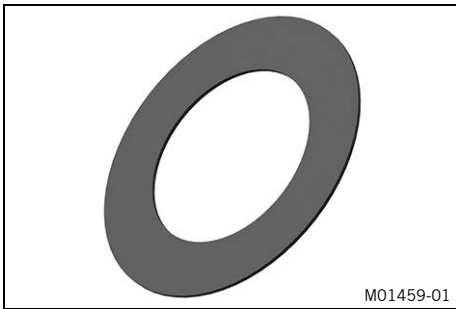

(All 450 models)

- Change the clutch spring. 🛠️

Clutch spring, hard (78932005000)

8.7 Preparing the vehicle for riding on wet and muddy circuits



- Mount the air filter rain cover.

Air filter rain cover (79006921000)



Info

Observe the fitting instructions for **KTM PowerParts**.



- Mount the steel sprocket.
- Clean the motorcycle. (📖 p. 147)
- Straighten the bent radiator fins carefully.

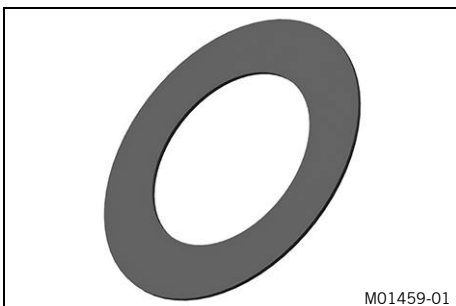

(All 450 models)

- Change the clutch spring. 🛠️

Clutch spring, hard (78932005000)

8.8 Preparing vehicle for high temperatures or slow riding



- Adjust the secondary drive to the road conditions.



Info

The engine oil heats up quickly when the clutch is operated frequently due to an excessively high secondary ratio.

- Clean the chain.

Chain cleaner (📖 p. 166)

- Clean the radiator fins.

- Straighten the bent radiator fins carefully.
- Check the coolant level. (📖 p. 132)

8.9 Preparing the vehicle for low temperatures or snow



- Mount the air filter rain cover.

Air filter rain cover (79006921000)



Info

Observe the fitting instructions for **KTM PowerParts**.

9.1 Checks and maintenance measures when preparing for use

i Info

Before every trip, check the condition of the vehicle and ensure that it is safe to operate. The vehicle must be in perfect technical condition when it is being operated.

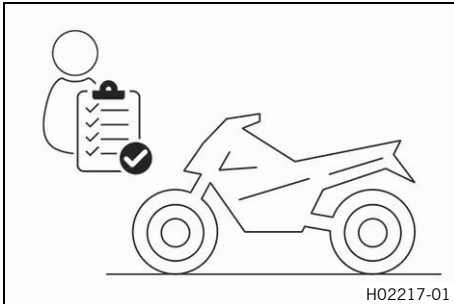

- Check the engine oil level. (📖 p. 143)
- Check the electrical system.
- Check front brake fluid level. (📖 p. 100)
- Check the rear brake fluid level. (📖 p. 108)
- Check the front brake linings. (📖 p. 102)
- Check the rear brake linings. (📖 p. 109)
- Check that the brake system is functioning properly.
- Check the coolant level. (📖 p. 132)
- Check for chain dirt accumulation. (📖 p. 88)
- Check the chain, rear sprocket, engine sprocket, and chain guide. (📖 p. 91)
- Check the chain tension. (📖 p. 89)
- Check the tire condition. (📖 p. 117)
- Check tire pressure. (📖 p. 117)
- Check the spoke tension. (📖 p. 118)

i Info

The spoke tension must be checked regularly as incorrect spoke tension will strongly impair riding safety.

- Clean the dust boots of the fork legs. (📖 p. 64)
- Bleed the fork legs. (📖 p. 63)
- Check the air filter.
- Check the settings of all controls and ensure that they can be operated smoothly.
- Check all screws, nuts, and hose clamps regularly for tightness.
- Check the fuel level.



9.2 Starting the vehicle



Danger

Danger of poisoning Exhaust gases are toxic and inhaling them may result in unconsciousness and death.

- Always make sure there is sufficient ventilation when running the engine.
- Use effective exhaust extraction when starting or running the engine in an enclosed space.

Note

Engine damage High revving speed with a cold engine negatively impacts the lifespan of the engine.

- Always run the engine warm at a low speed.

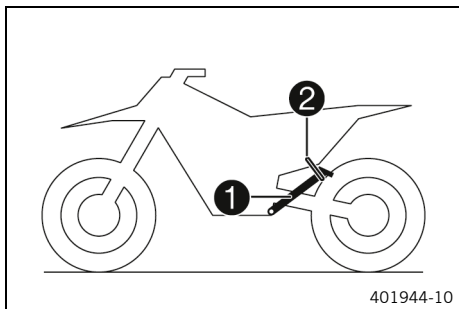

- Take the motorcycle off side stand **1** and secure the side stand with rubber strap **2**.
- Shift the transmission into neutral.
- Turn the emergency OFF switch to the position \circ .

Condition

Ambient temperature: < 20 °C (< 68 °F)

- Push the cold start button in all the way.

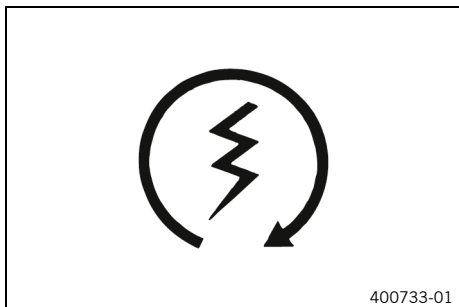

- Press the start button.

i Info

Press the start button for a maximum of 5 seconds. Wait for 30 seconds before a further attempt at starting.

At temperatures below 15 °C (60 °F), several attempts at starting may be necessary to warm-up the lithium-ion battery and thereby increase the starting power.

During the starting process, the malfunction indicator lamp lights up.

9.3 Activating traction control (EXC-F SIX DAYS, XCF-W)



Warning

Voiding of the government approval for road use and the insurance coverage If the combination switch is mounted, the vehicle's road permit, if any, expires.

- Only operate the vehicle in closed-off areas remote from public road traffic if the combination switch is installed.



Info

The traction control reduces excessive slip on the rear wheel in favor of more control and propulsion, particularly in wet conditions.

When traction control is switched off, the rear wheel may spin more during high acceleration and on surfaces with low grip.

Traction control can be switched on or off during the ride.

The setting most recently selected is activated again when restarting.

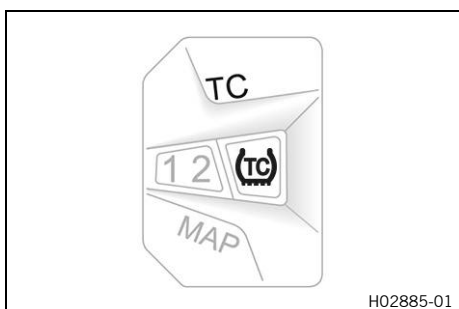

- Press button **TC** to switch the traction control on or off.

Guideline

Engine speed	≤ 4,000 rpm
--------------	-------------

- ✓ The **TC** LED lights up when the traction control is activated.

9.4 Starting off

Info

When you are riding, the side stand must be folded up and secured with the rubber strap.

- Pull the clutch lever, shift into first gear, release the clutch lever slowly and at the same time open the throttle carefully.



9.5 Shifting, riding



Warning

Danger of accidents If you change down at high engine speed, the rear wheel blocks and the engine races.

- Do not change into a low gear at high engine speed.

Info

If unusual noises occur while riding, stop immediately, switch off the engine and contact an authorized KTM workshop.

First-gear is used for starting off and for steep inclines.

- Shift into a higher gear when conditions allow (incline, road situation, etc.). To do so, release the throttle while simultaneously pulling the clutch lever, shift into the next gear, release the clutch lever and open the throttle.
- After reaching maximum speed by fully opening the throttle grip, turn the throttle back so it is $\frac{3}{4}$ open. This will barely reduce the speed, but fuel consumption will be considerably lower.
- Always open the throttle only as much as the engine can handle – abrupt throttle opening increases fuel consumption.
- To shift down, apply the brakes and close the throttle at the same time.
- Pull the clutch lever and shift into a lower gear, release the clutch lever slowly, and either open the throttle or shift again.
- Switch off the engine if running at idle speed or stationary for a long time.

Guideline

≥ 2 min

- Avoid frequent and lengthy slipping of the clutch. This causes the engine oil, engine and cooling system to heat up.
- Ride at a low engine speed instead of at a high engine speed with a slipping clutch.



9.6 Braking



Warning

Danger of accidents Excessively forceful application of the brakes blocks the wheels.

- Adjust application of the brakes to the respective riding situation and riding surface conditions.



Warning

Danger of accidents A spongy pressure point on the front or rear brake reduces braking efficiency.

- Check the brake system and do not continue riding until the problem is eliminated. (Your authorized KTM workshop will be glad to help.)



Warning

Danger of accidents Moisture and dirt impair the brake system.

- Brake carefully several times to dry out and remove dirt from the brake linings and the brake discs.

- On sandy, wet, or slippery surfaces, use the rear brake.
- Always finish braking before you go into a bend. Change down to a lower gear appropriate to your road speed.
- Use the braking effect of the engine on long downhill stretches. Change down one or two gears, but do not over-rev the engine. You will have to apply the brakes far less frequently as a result and the brake system will not overheat.

9.7 Stopping, parking



Warning

Risk of injury People who act without authorization may not be familiar with the vehicle.

- Do not leave the vehicle unattended if the engine is running.
- Protect the vehicle against access by unauthorized persons.



Warning

Danger of burns Some vehicle components become very hot when the vehicle is operated.

- Do not touch any parts such as the exhaust system, radiator, engine, shock absorber, or brake system before the vehicle parts have cooled down.
- Let the vehicle parts cool down before you perform any work on the vehicle.

Note

Fire hazard Hot vehicle components pose a fire hazard and explosion risk.

- Do not park the vehicle near to materials which are highly flammable or explosive.
- Allow the vehicle to cool down before covering it.

Note

Material damage The vehicle may be damaged by incorrect procedure when parking.

Significant damage may be caused if the vehicle rolls away or falls over.

The components for parking the vehicle are designed only for the weight of the vehicle.

- Park the vehicle on a firm and level surface.
- Ensure that nobody sits on the vehicle when the vehicle is parked on a stand.

- Apply brakes on the motorcycle.
- Shift the transmission into neutral.
- Press and hold the stop button  while the engine is idling until the engine stops.
- Park the motorcycle on firm ground.

9.8 Transporting

Note

Danger of damage The parked vehicle can roll away or fall over.

- Park the vehicle on a firm and level surface.

Note

Fire hazard Hot vehicle components pose a fire hazard and explosion risk.

- Do not park the vehicle near to materials which are highly flammable or explosive.
- Allow the vehicle to cool down before covering it.

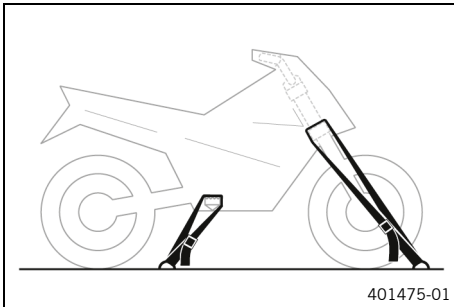

- Switch off the engine.
- Use tension belts or other suitable devices to secure the motorcycle against falling over or rolling away.

9.9 Refueling



Danger

Fire hazard Fuel is highly flammable.

The fuel in the fuel tank expands when warm and can escape if overfilled.

- Do not fuel the vehicle in the vicinity of open flames or lit cigarettes.
- Switch off the engine for refueling.
- Make sure that no fuel is spilled; particularly not on hot parts of the vehicle.
- If any fuel is spilled, wipe it off immediately.
- Observe the specifications for refueling.



Warning

Danger of poisoning Fuel is poisonous and a health hazard.

- Avoid skin, eye and clothing contact with fuel.
- Immediately consult a doctor if you swallow fuel.
- Do not inhale fuel vapors.
- In case of skin contact, rinse the affected area with plenty of water.
- Rinse the eyes thoroughly with water, and consult a doctor in case of fuel contact with the eyes.
- Change your clothing in case of fuel spills on them.

Note

Material damage Inadequate fuel quality causes the fuel filter to quickly become clogged.

In some countries and regions, the available fuel quality and cleanliness may not be sufficient. This will result in problems with the fuel system.

- Refuel only with clean fuel that meets the specified standards. (Your authorized KTM workshop will be glad to help.)



Note

Environmental hazard Improper handling of fuel is a danger to the environment.

- Do not allow fuel to enter the groundwater, the soil, or the sewage system.

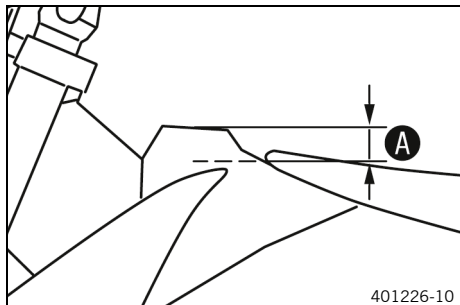

- Switch off engine.
- Open fuel tank filler cap. (📖 p. 20)
- Fill the fuel tank with fuel up to measurement **A**.

Guideline

Measurement of A	35 mm (1.38 in)	
Total fuel tank capacity, approx. (All EU models)	9 l (2.4 US gal)	Super unleaded (ROZ 95) (📖 p. 165)
Total fuel tank capacity, approx. (XCF-W)	8.5 l (2.25 US gal)	Super unleaded (ROZ 95) (📖 p. 165)

- Close the fuel tank filler cap. (📖 p. 20)

10.1 Additional information

Any further work that results from the compulsory work or from the recommended work must be ordered separately and invoiced separately.

Different service intervals may apply in your country, depending on the local operating conditions.

Individual service intervals and scopes may change in the course of technical developments. The most up-to-date service schedule can always be found on KTM Dealer.net. Your authorized KTM dealer will be happy to advise you.

10.2 Required work

	Every 10 operating hours when used for motorsports	Every 45 operating hours	Every 30 operating hours	Every 15 operating hours	After 1 operating hour
Read out the fault memory using the KTM diagnostics tool. 🛠️	○	●	●	●	●
Check that the electrical system is functioning properly.	○	●	●	●	●
Check and charge the 12-V battery. 🛠️		●	●	●	●
Check the front brake linings. (📖 p. 102)		●	●	●	●
Check the rear brake linings. (📖 p. 109)		●	●	●	●
Check the brake discs. (📖 p. 99)		●	●	●	●
Check the brake lines for damage and leakage.		●	●	●	●
Check the rear brake fluid level. (📖 p. 108)		●	●	●	●
Check the free travel of the foot brake lever. (📖 p. 106)		●	●	●	●
Check the frame. 🛠️ (📖 p. 93)		●	●	●	●
Check the link fork. 🛠️ (📖 p. 93)		●	●	●	●
Check the fork bearing for play. 🛠️			●		
Check the shock absorber heim joint for play. 🛠️		●	●	●	
Check the tire condition. (📖 p. 117)	○	●	●	●	●
Check tire pressure. (📖 p. 117)	○	●	●	●	●
Check the wheel bearing for play. 🛠️		●	●	●	●
Check the wheel hubs. 🛠️		●	●	●	●
Check the rim run-out. 🛠️	○	●	●	●	
Check the spoke tension. (📖 p. 118)	○	●	●	●	●
Check the chain, rear sprocket, engine sprocket, and chain guide. (📖 p. 91)		●	●	●	●
Check the chain tension. (📖 p. 89)	○	●	●	●	●
Grease all moving parts (e.g. side stand, hand lever, chain, etc.) and check for smooth operation. 🛠️		●	●	●	●
Check/correct the fluid level of the hydraulic clutch. (📖 p. 95)		●	●	●	●
Check front brake fluid level. (📖 p. 100)		●	●	●	●
Check the free travel of the hand brake lever. 🛠️		●	●	●	●
Check steering head bearing play. (📖 p. 72)	○	●	●	●	
Check the valve clearance. 🛠️	○		●		
Check the clutch. 🛠️			●		●
Change the engine oil and the oil filter, clean the oil screens. 🛠️ (📖 p. 143)	○	●	●	●	●
Check all hoses (e.g. fuel, cooling, bleeder, drainage, etc.) and sleeves for cracking, leaks, and incorrect routing. 🛠️	○	●	●	●	●

	Every 10 operating hours when used for motorsports				
	Every 45 operating hours				
	Every 30 operating hours				
	Every 15 operating hours				
	After 1 operating hour				
Check the antifreeze and coolant level. (📖 p. 131)	○	●	●	●	●
Check the cables for damage and for routing without kinks. 🛠️		●	●	●	●
Check that the throttle cables are undamaged, routed without sharp bends, and set correctly.	○	●	●	●	●
Clean the air filter and air filter box. 🛠️ (📖 p. 80)		●	●	●	●
Change the glass fiber yarn filling of the main silencer. 🛠️ (📖 p. 84)			●		●
Service the fork. 🛠️					●
Perform the shock absorber service. 🛠️					●
Check the tightness of the easily accessible, safety-relevant screws and nuts. 🛠️	○	●	●	●	●
Check the headlight setting. (📖 p. 127)	○	●	●	●	●
Change the fuel screen. 🛠️ (📖 p. 142)	○	●	●	●	●
Check the fuel pressure. 🛠️		●	●	●	●
Check the idle speed. 🛠️	○	●	●	●	●
Check that the radiator fan is functioning properly. 🛠️	○	●	●	●	
Check the inlet membrane. 🛠️					●
Final check: Check the vehicle is roadworthy and take a test ride. 🛠️	○	●	●	●	●
Read out the error memory after the test ride using the KTM diagnostics tool. 🛠️	○	●	●	●	●
Make a service entry in KTM Dealer.net . 🛠️	○	●	●	●	●

- One-time interval
- Periodic interval

10.3 Recommended work

	every 48 months				
	every 12 months				
	Every 135 operating hours				
	Every 70 operating hours when used for motorsports				
	After 20 operating hours				
	After 10 operating hours				
Change the front brake fluid. 🛠️					● ●
Change the rear brake fluid. 🛠️					● ●
Change the hydraulic clutch fluid. 🛠️ (📖 p. 96)					● ●
Lubricate the steering head bearing. 🛠️ (📖 p. 74)					● ●
Clean the spark arrestor. (XCF-W) 🛠️ (📖 p. 82)					● ●
Service the fork. 🛠️	○				
Perform the shock absorber service. 🛠️		○			
Change the fuel filter. 🛠️				●	
Change the coolant. (📖 p. 134)					●

	every 48 months	every 12 months	Every 135 operating hours	Every 70 operating hours when used for motorsports	After 20 operating hours	After 10 operating hours
Perform engine service including removing and installing the engine. (Change the spark plug and spark plug connector. Change the piston. Check/measure the cylinder. Check the cylinder head. Change the valves, valve springs, and valve spring seats. Check the camshaft, rocker arm and rocker arm shafts. Change the connecting rod, conrod bearing and crank pin. Change the radial shaft seal ring of the water pump. Check the transmission and the shift mechanism. Check the oil pressure control valve. Change the suction pump. Check the force pump and lubrication system. Check the timing assembly. Change the timing chain. Change all engine bearings. Change the freewheel.) 			•	•		

- One-time interval
- Periodic interval

11.1 Checking the basic chassis setting with rider's weight

i Info

When adjusting the basic chassis setting, first adjust the shock absorber and then the fork.

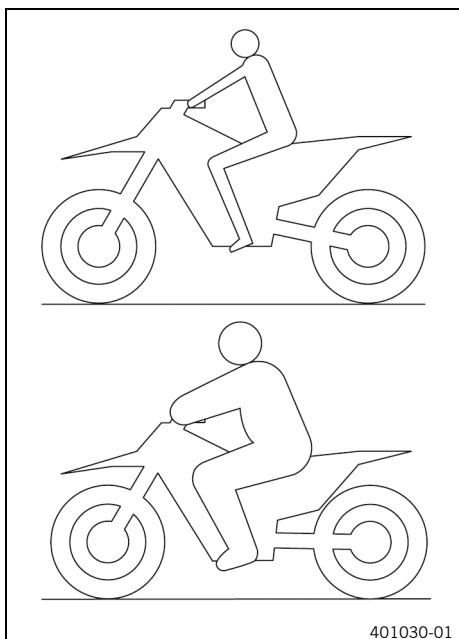

- For optimal motorcycle riding characteristics and to avoid damage to forks, shock absorbers, link fork and frame, the basic settings of the suspension components must match the rider's weight.
- As delivered, KTM offroad motorcycles are adjusted for an average rider's weight (with full protective clothing).

Guideline

Standard rider weight	75 ... 85 kg (165 ... 187 lb.)
-----------------------	--------------------------------

- If the rider's weight is above or below this range, the basic setting of the suspension components must be adjusted accordingly.
- Small weight differences can be compensated by adjusting the spring preload, but in the case of large weight differences, the springs must be replaced.

11.2 Compression damping of the shock absorber

The compression damping of the shock absorber is divided into two ranges: high-speed and low-speed.

High-speed and low-speed refer to the compression speed of the rear wheel suspension and not to the vehicle speed.

The high-speed compression adjuster has an effect, for example, when landing after a jump: the rear wheel suspension compresses quickly.

The low-speed compression adjuster has an effect, for example, when riding over long ground swells: the rear wheel suspension compresses slowly.

These two ranges can be adjusted separately, although the transition between high-speed and low-speed is gradual. Thus, modifications in the high-speed range affect the compression damping in the low-speed range and vice versa.

11.3 Adjusting the low-speed compression damping of the shock absorber



Caution

Risk of injury Parts of the shock absorber will move around if the shock absorber is detached incorrectly.

The shock absorber is filled with highly compressed nitrogen.

- Please follow the description provided. (Your authorized KTM workshop will be glad to help.)

i Info

The effect of the low-speed compression adjuster can be seen in slow to normal compression of the shock absorber.

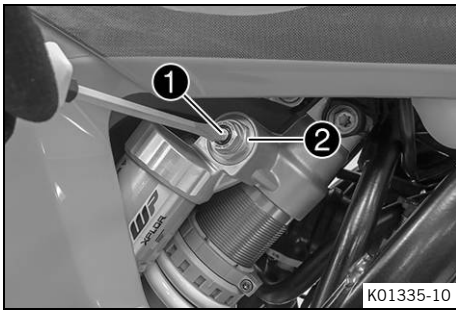

- Turn adjusting screw ① clockwise with a screwdriver as far as the last perceptible click.

i Info
Do not loosen fitting ②!

- Turn counterclockwise by the number of clicks corresponding to the shock absorber type.

Guideline

Low-speed compression damping	
Comfort	18 clicks
Standard	15 clicks
Sport	12 clicks

i Info
Turn clockwise to increase damping; turn counterclockwise to reduce damping.



11.4 Adjusting the high-speed compression damping of the shock absorber

! Caution
Risk of injury Parts of the shock absorber will move around if the shock absorber is detached incorrectly. The shock absorber is filled with highly compressed nitrogen.
- Please follow the description provided. (Your authorized KTM workshop will be glad to help.)

i Info
The effect of the high speed compression adjuster can be seen in the fast compression of the shock absorber.

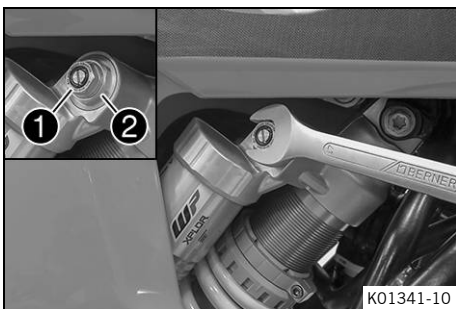

- Using an open end wrench, turn adjusting screw ① clockwise all the way.

i Info
Do not loosen fitting ②!

- Turn counterclockwise by the number of turns corresponding to the shock absorber type.

Guideline

High-speed compression damping	
Comfort	2.5 turns
Standard	2 turns
Sport	1 turn

i Info
Turn clockwise to increase damping; turn counterclockwise to reduce damping during compression.



11.5 Adjusting the rebound damping of the shock absorber



Caution

Risk of injury Parts of the shock absorber will move around if the shock absorber is detached incorrectly.

The shock absorber is filled with highly compressed nitrogen.

- Please follow the description provided. (Your authorized KTM workshop will be glad to help.)

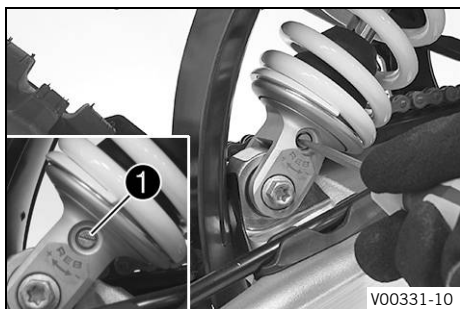

- Turn adjusting screw **1** clockwise up to the last perceptible click.
- Turn counterclockwise by the number of clicks corresponding to the shock absorber type.

Guideline

Rebound damping	
Comfort	18 clicks
Standard	15 clicks
Sport	12 clicks



Info

Turn clockwise to increase the damping; turn counterclockwise to reduce damping when the shock absorber rebounds.

11.6 Measuring the dimension of the rear wheel unloaded

Preparatory work

- Raise the motorcycle with the lift stand. (📖 p. 63)

Main work

- Position the sag gage in the rear axle and measure the distance to marking **SAG** on the rear fender.

Sag gauge (00029090100)
Pin, sag scale (00029990010)

- Note the value as dimension **A**.

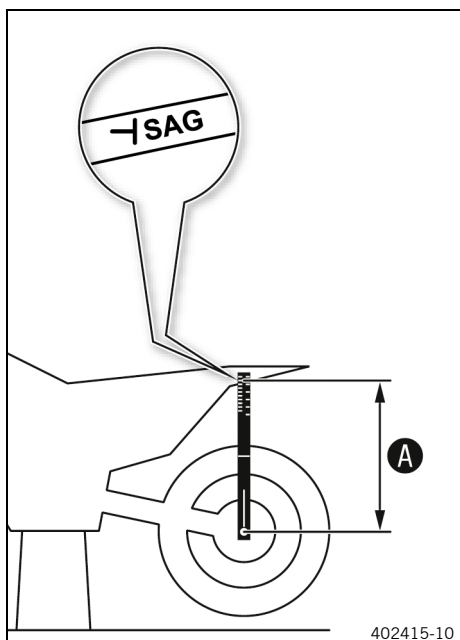

Finishing work

- Remove the motorcycle from the lift stand. (📖 p. 63)

11.7 Checking the static sag of the shock absorber

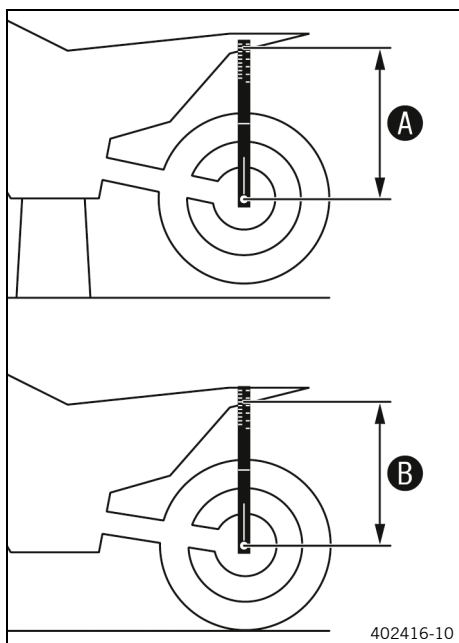

- Measure dimension **A** of rear wheel unloaded. (📖 p. 54)
- Hold the motorcycle upright with aid of an assistant.
- Measure the distance again between the rear axle and marking **SAG** on the rear fender using the sag gage.
- Note the value as dimension **B**.

i Info
The static sag is the difference between measurements **A** and **B**.

- Check the static sag.

Static sag	37 mm (1.46 in)
------------	-----------------

- » If the static sag is less or more than the specified value:
 - Adjust the spring preload of the shock absorber. (🔧 p. 56)



11.8 Checking the riding sag of the shock absorber

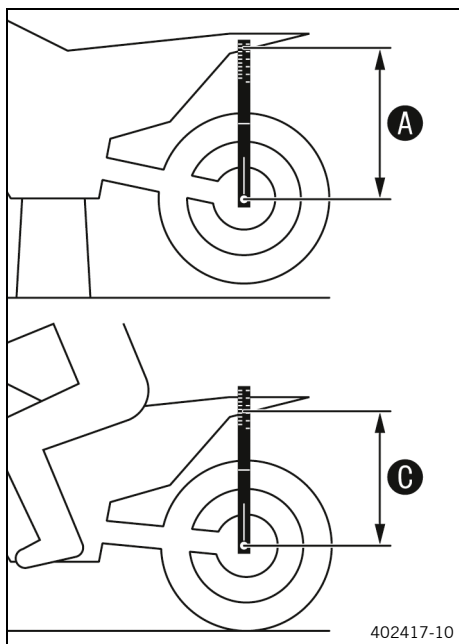

- Measure dimension **A** of rear wheel unloaded. (📖 p. 54)
- With another person holding the motorcycle, the rider, wearing full protective clothing, sits on the seat in a normal sitting position (feet on footrests) and bounces up and down a few times.
 - ✓ The rear wheel suspension levels out.
- Another person again measures the distance between the rear axle and marking **SAG** on the rear fender using the sag gage.
- Note the value as dimension **C**.

i Info
The riding sag is the difference between measurements **A** and **C**.

- Check riding sag.

Riding sag	110 mm (4.33 in)
------------	------------------

- » If the riding sag differs from the specified measurement:
 - Adjust the riding sag. (🔧📖 p. 57)



11.9 Adjusting the spring preload of the shock absorber ↩



Caution

Risk of injury Parts of the shock absorber will move around if the shock absorber is detached incorrectly.

The shock absorber is filled with highly compressed nitrogen.

- Please follow the description provided. (Your authorized KTM workshop will be glad to help.)



Info

Before changing the spring preload, make a note of the present setting, e.g., by measuring the spring length.

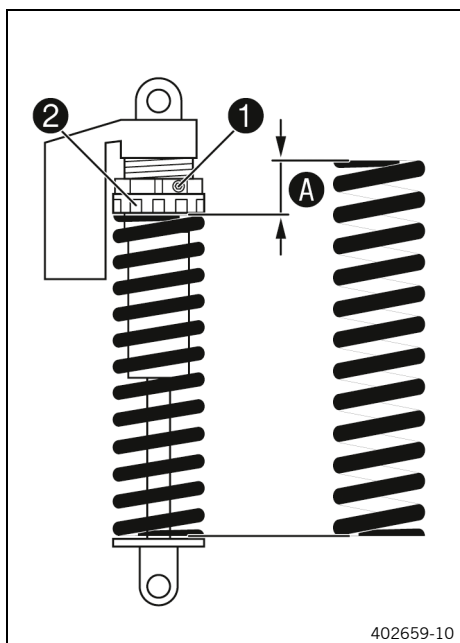

Preparatory work

- Raise the motorcycle with the lift stand. (📖 p. 63)
- Remove the shock absorber. ↩ (📖 p. 76)
- After removing the shock absorber, clean it thoroughly.

Main work

- Loosen screw ①.
- Turn adjusting ring ② until the spring is no longer under tension.

Hook wrench (90129051000)



Info

If the spring cannot be fully released, the spring must be removed to accurately measure the spring length.

- Measure the total spring length while the spring is not under tension.
- Tension the spring by turning adjusting ring ② to specified dimension A.

Guideline

Spring preload	10 mm (0.39 in)
----------------	-----------------



Info

Depending on the static sag and/or the riding sag, it may be necessary to increase or decrease the spring preload.

- Tighten bolt ①.

Guideline

Screw, shock absorber adjusting ring	M5	5 Nm (3.7 lbf ft)
--------------------------------------	----	-------------------

Finishing work

- Install the shock absorber. ↩ (📖 p. 76)
- Remove the motorcycle from the lift stand. (📖 p. 63)

11.10 Adjusting the riding sag 🛠️

Preparatory work

- Raise the motorcycle with the lift stand. (📖 p. 63)
- Remove the shock absorber. 🛠️ (📖 p. 76)
- After removing the shock absorber, clean it thoroughly.

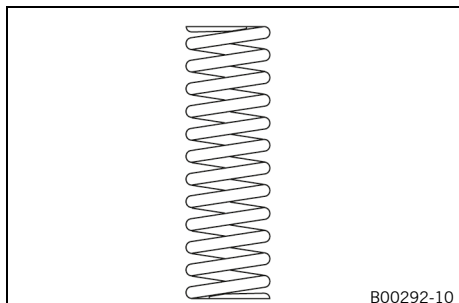

Main work

- Choose and mount a suitable spring.

Guideline

Spring rate	
Weight of rider: 65 ... 75 kg (143 ... 165 lb.)	60 ... 66 N/mm (343 ... 377 lb/in)
Weight of rider: 75 ... 85 kg (165 ... 187 lb.)	63 ... 69 N/mm (360 ... 394 lb/in)
Weight of rider: 85 ... 95 kg (187 ... 209 lb.)	66 ... 72 N/mm (377 ... 411 lb/in)



Info

The spring rate is shown on the outside of the spring. Smaller weight differences can be compensated by changing the spring preload.

Finishing work

- Install the shock absorber. 🛠️ (📖 p. 76)
- Remove the motorcycle from the lift stand. (📖 p. 63)
- Check the static sag of the shock absorber. (📖 p. 55)
- Check the riding sag of the shock absorber. (📖 p. 55)
- Adjust the rebound damping of the shock absorber. (📖 p. 54)



11.11 Checking the basic setting of the fork



Info

For various reasons, no exact riding sag can be determined for the fork.

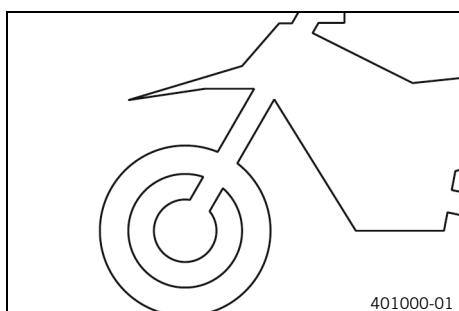

- As with the shock absorber, smaller differences in the rider's weight can be compensated by the spring preload.
- However, if the fork frequently bottoms out (hard end stop on compression), harder springs must be fitted to avoid damage to the fork and frame.
- If the fork feels unusually hard after extended periods of operation, the fork legs need to be bled.



11.12 Adjusting the compression damping of the fork

i **Info**

The hydraulic compression damping determines the fork suspension behavior.

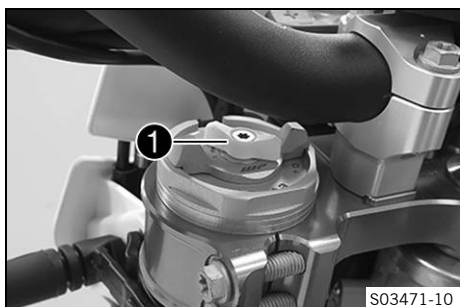

- Turn white adjuster ① clockwise as far as it will go.

i **Info**

Adjuster ① is located at the upper end of the left fork leg.

The compression damping is located in left fork leg **COM** (white adjuster). The rebound damping is located in right fork leg **REB** (red adjuster).

- Turn counterclockwise by the number of clicks corresponding to the fork type.

Guideline

Compression damping	
Comfort	18 clicks
Standard	15 clicks
Sport	12 clicks

i **Info**

Turn clockwise to increase damping; turn counterclockwise to reduce damping during compression.

11.13 Adjusting the rebound damping of the fork

i **Info**

The hydraulic rebound damping determines the fork suspension behavior.

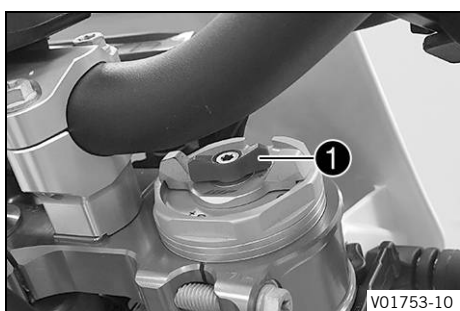

- Turn red adjuster ① clockwise as far as it will go.

i **Info**

Adjuster ① is located at the upper end of the right fork leg.

The rebound damping is located in right fork leg **REB** (red adjuster). The compression damping is located in left fork leg **COM** (white adjuster).

- Turn counterclockwise by the number of clicks corresponding to the fork type.

Guideline

Rebound damping	
Comfort	18 clicks
Standard	15 clicks
Sport	12 clicks



Info

Turn clockwise to increase the damping; turn counterclockwise to reduce damping when the shock absorber rebounds.

11.14 Adjusting the spring preload of the fork

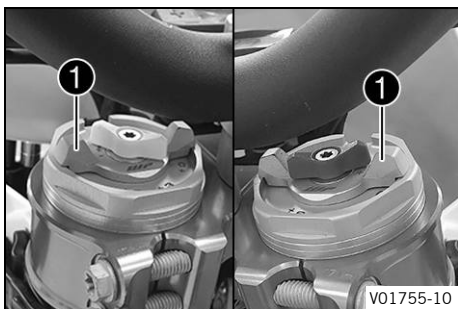

Preparatory work

- Raise the motorcycle with the lift stand. (📖 p. 63)

Main work

- Turn T-grips ① counterclockwise all the way.
- ✓ The marking **+0** aligns with the right wing.



Info

Make the adjustment by hand only. Do not use a tool. Make the same adjustment on both fork legs.

- Turn the T-grips clockwise.

Guideline

Spring preload – preload adjuster	
Comfort	+0
Standard	+0
Sport	+3

- ✓ The T-grips engage noticeably at the numerical values.



Info

Adjust the spring preload to the numerical values only as the preload will not engage between the numerical values.

Turn clockwise to increase the spring preload; turn counterclockwise to reduce the spring preload.

Adjusting the spring preload has no influence on the absorption setting of the rebound.

Basically, however, you should set the rebound damping higher with a higher spring preload.

Finishing work

- Remove the motorcycle from the lift stand. (📖 p. 63)

11.15 Handlebar position

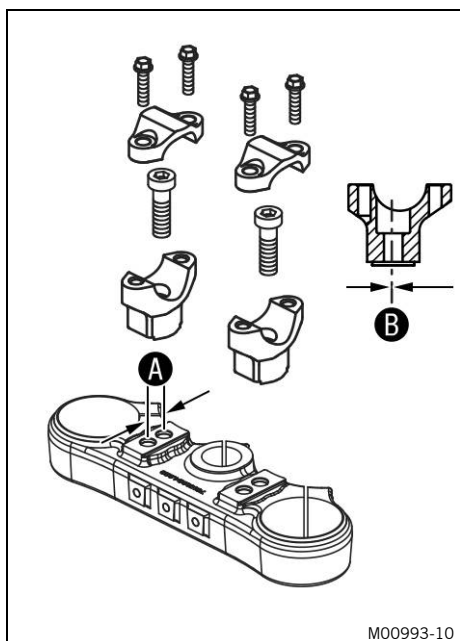

(EXC-F EU, XCF-W)

On the upper triple clamp, there are 2 holes at a distance of **A** to each other.

Hole distance A	15 mm (0.59 in)
------------------------	-----------------

The holes on the handlebar supports are placed at a distance of **B** from the center.

Hole distance B	3.5 mm (0.138 in)
------------------------	-------------------

The handlebar holders can be mounted in four different positions.

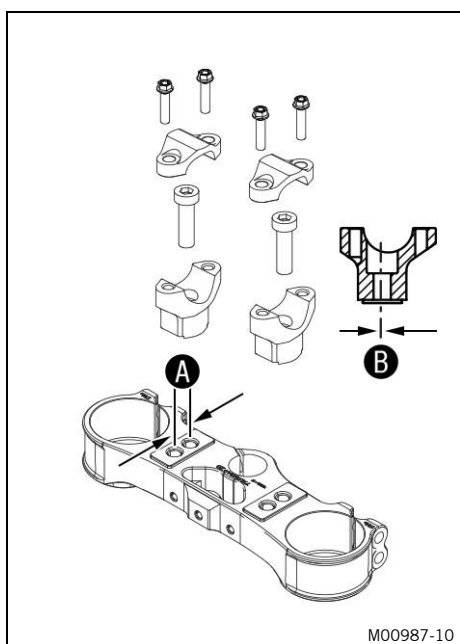

(EXC-F SIX DAYS EU)

On the upper triple clamp, there are 2 holes at a distance of **A** to each other.

Hole distance A	15 mm (0.59 in)
------------------------	-----------------

The holes on the handlebar supports are placed at a distance of **B** from the center.

Hole distance B	3.5 mm (0.138 in)
------------------------	-------------------

The handlebar holders can be mounted in four different positions.

11.16 Adjusting the handlebar position



Warning

Danger of accidents A repaired handlebar poses a safety risk.

If the handlebar is bent or straightened, the material becomes fatigued. The handlebar may break as a result.

- Change the handlebar if the handlebar is damaged or bent.

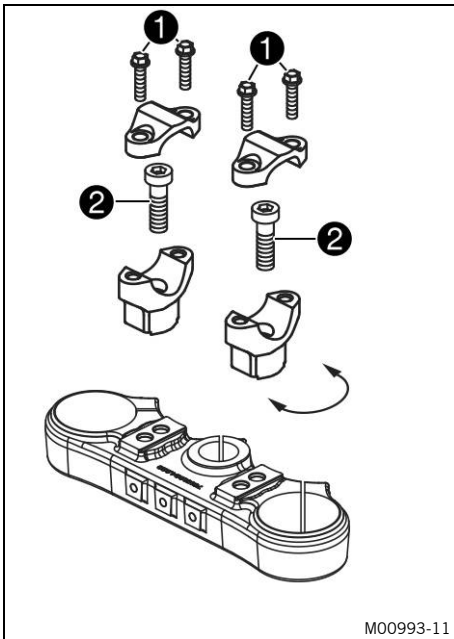

(EXC-F EU, XCF-W)

- Remove screws **1**. Take off the handlebar clamps. Remove the handlebar and lay it to one side.

i Info
Cover the components to protect them against damage.
Do not kink the cables and lines.

- Remove screws **2**. Take off the handlebar supports.
- Place the handlebar supports in the required position. Mount and tighten screws **2**.

Guideline

Screw, handlebar holder	M10	40 Nm (29.5 lbf ft) Loctite®243™
-------------------------	-----	--

i Info
Position the left and right handlebar supports evenly.

- Position the handlebar.

i Info
Make sure the cables and wiring are positioned correctly.

- Position the handlebar clamps. Mount screws **1** and tighten evenly.

Guideline

Screw, handlebar clamp	M8	20 Nm (14.8 lbf ft)
------------------------	----	------------------------

i Info
Make sure the gap widths are even.

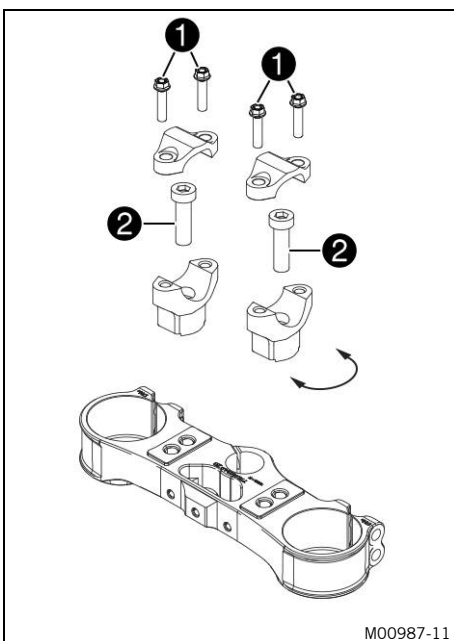

(EXC-F SIX DAYS EU)

- Remove screws **1**. Take off the handlebar clamps. Remove the handlebar and lay it to one side.

i Info
Cover the components to protect them against damage.
Do not kink the cables and lines.

- Remove screws **2**. Take off the handlebar supports.
- Place the handlebar supports in the required position. Mount and tighten screws **2**.

Guideline

Screw, handlebar holder	M10	40 Nm (29.5 lbf ft) Loctite®243™
-------------------------	-----	--

i Info
Position the left and right handlebar supports evenly.

- Position the handlebar.

i Info Make sure the cables and wiring are positioned correctly.

- Position the handlebar clamps. Mount screws **1** and tighten evenly.

Guideline

Screw, handlebar clamp	M8	20 Nm (14.8 lbf ft)
------------------------	----	------------------------

i Info Make sure the gap widths are even.

12.1 Raising the motorcycle with the lift stand

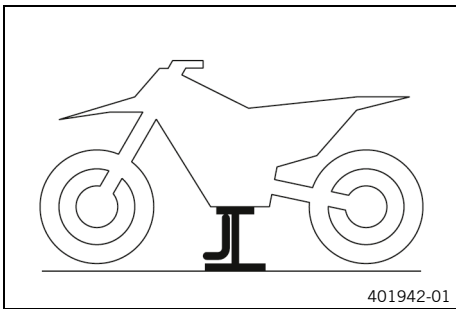

Note

Danger of damage The parked vehicle can roll away or fall over.

- Park the vehicle on a firm and level surface.
- Raise the motorcycle at the frame underneath the engine.

Lift stand (78129955100)

- ✓ Neither wheel is in contact with the ground.
- Secure the motorcycle against falling over.



12.2 Removing the motorcycle from the lift stand

Note

Danger of damage The parked vehicle can roll away or fall over.

- Park the vehicle on a firm and level surface.

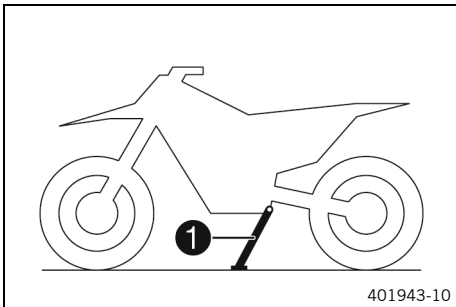

- Remove the motorcycle from the lift stand.
- Remove the lift stand.
- To park the motorcycle, press side stand ① to the ground with your foot and lean the motorcycle on it.



Info

When you are riding, the side stand must be folded up and secured with rubber strap.



12.3 Bleeding the fork legs

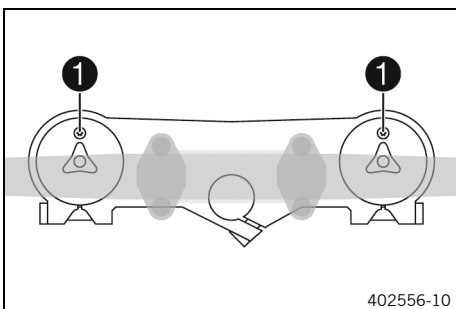

Preparatory work

- Raise the motorcycle with the lift stand. (📖 p. 63)

Main work

- Release bleeder screws ①.
- ✓ Any excess pressure escapes from the interior of the fork.
- Tighten the bleeder screws.

Finishing work

- Remove the motorcycle from the lift stand. (📖 p. 63)



12.4 Cleaning the dust boots of the fork legs



Preparatory work

- Raise the motorcycle with the lift stand. (📖 p. 63)
- Remove the fork protector. (📖 p. 64)

Main work

- Push dust boots ❶ of both fork legs downward.

Info

The dust boots remove dust and coarse dirt particles from the inside fork tubes. Over time, dirt can accumulate behind the dust boots. If this dirt is not removed, the oil seals behind can start to leak.



Warning

Danger of accidents Oil or grease on the brake discs reduces the braking effect.

- Always keep the brake discs free of oil and grease.
- Clean the brake discs with brake cleaner when necessary.

- Clean and oil the dust boots and inner fork tubes of both fork legs.

Universal oil spray (📖 p. 167)

- Press the dust boots back into their installation position.
- Remove excess oil.

Finishing work

- Install the fork protector. (📖 p. 65)
- Remove the motorcycle from the lift stand. (📖 p. 63)

12.5 Removing the fork protector

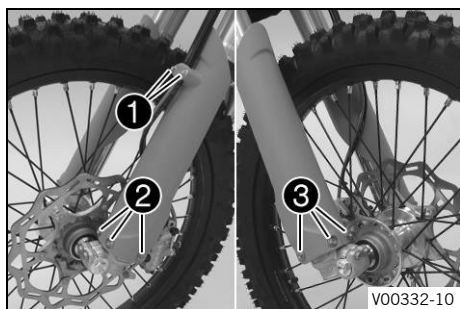

- Remove screws ❶ and take off the clamp.
- Remove screws ❷ on the left fork leg and take off the left fork protector.
- Remove screws ❸ on the right fork leg and take off the right fork protector.

12.6 Installing the fork protector

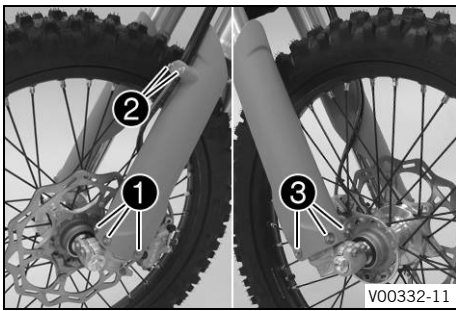

- Position the fork protector on the left fork leg. Mount and tighten screws ①.

Guideline

Remaining screws, chassis	M6	10 Nm (7.4 lbf ft)
---------------------------	----	--------------------

- Position the brake line, wiring harness, and clamp. Mount and tighten screws ②.
- Position the fork protector on the right fork leg. Mount and tighten screws ③.

Guideline

Remaining screws, chassis	M6	10 Nm (7.4 lbf ft)
---------------------------	----	--------------------

12.7 Removing the fork legs

Preparatory work

- Remove the headlight mask with the headlight. (p. 125)
- Raise the motorcycle with the lift stand. (p. 63)
- Remove the front wheel. (p. 113)

Main work

- Remove screws ① and take off the clamp.
- Remove the cable tie.
- Remove screws ② and take off the brake caliper.
- Allow the brake caliper and brake line to hang loosely to the side.

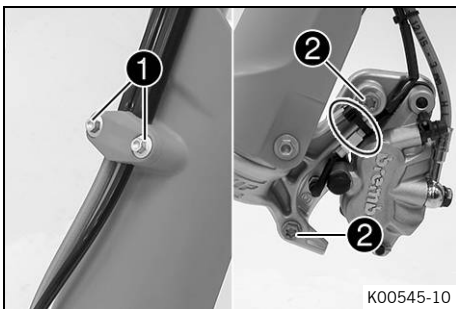

(EXC-F EU, XCF-W)

- Loosen screws ③. Remove the left fork leg.
- Loosen screws ④. Remove the right fork leg.

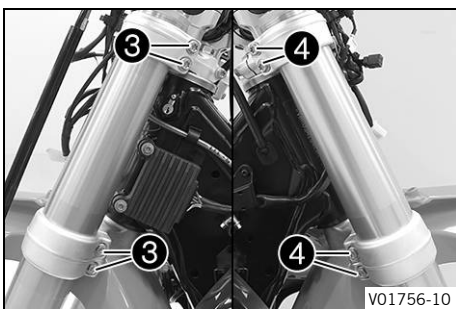

(EXC-F SIX DAYS EU)

- Loosen screws ③. Remove the left fork leg.
- Loosen screws ④. Remove the right fork leg.

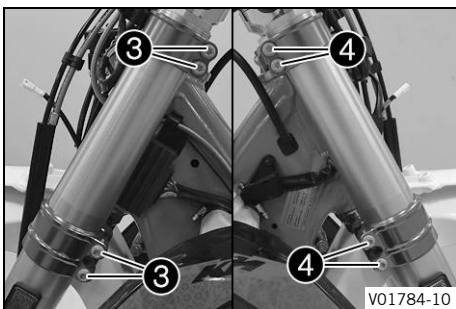

12.8 Installing the fork legs

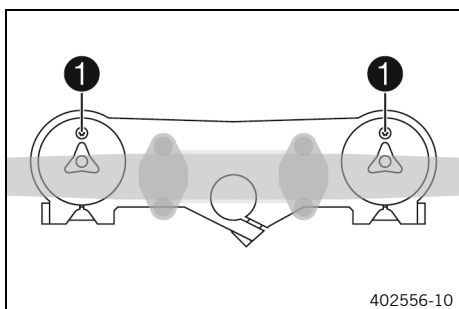

Main work (EXC-F EU, XCF-W)

- Position the fork legs.
- ✓ Bleeder screws **1** are positioned toward the front.



Info

The rebound damping is located in right fork leg **REB** (red adjusting screw). The compression damping is located in left fork leg **COMP** (white adjusting screw).

Grooves are milled into the side of the upper end of the fork legs. The second milled groove (from the top) must be flush with the upper edge of the upper triple clamp.

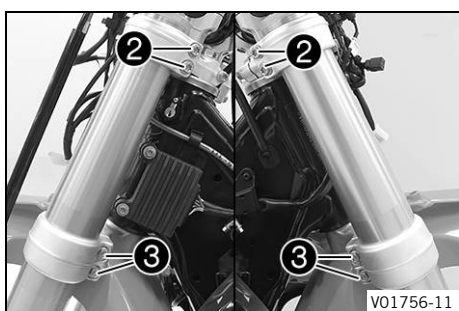

- Tighten screws **2**.

Guideline

Screw, top triple clamp	M8	20 Nm (14.8 lbf ft)
-------------------------	----	------------------------

- Tighten screws **3**.

Guideline

Screw, bottom triple clamp	M8	15 Nm (11.1 lbf ft)
----------------------------	----	------------------------

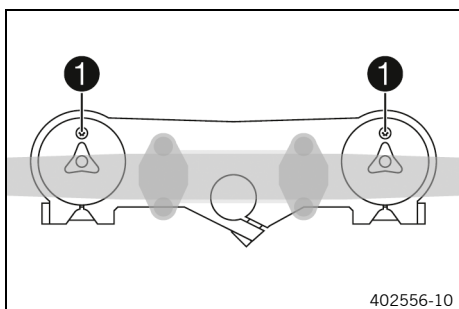

(EXC-F SIX DAYS EU)

- Position the fork legs.
- ✓ Bleeder screws **1** are positioned toward the front.



Info

The rebound damping is located in right fork leg **REB** (red adjusting screw). The compression damping is located in left fork leg **COM** (white adjusting screw).

Grooves are milled into the side of the upper end of the fork legs. The second milled groove (from the top) must be flush with the upper edge of the upper triple clamp.

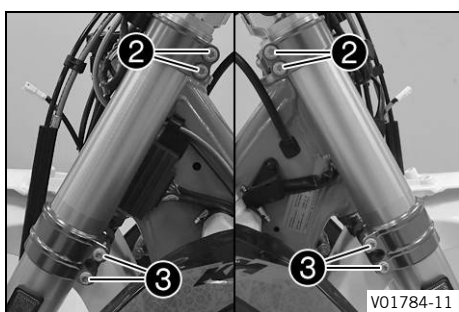

- Tighten screws **2**.

Guideline

Screw, top triple clamp	M8	17 Nm (12.5 lbf ft)
-------------------------	----	------------------------

- Tighten screws **3**.

Guideline

Screw, bottom triple clamp	M8	15 Nm (11.1 lbf ft)
----------------------------	----	------------------------

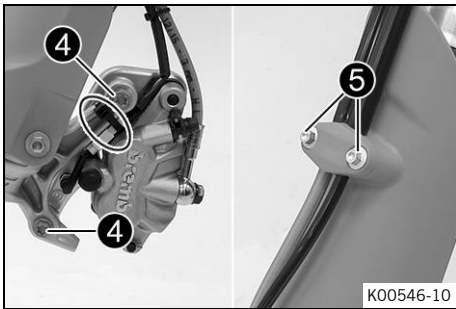

- Position the brake caliper, and mount and tighten screws ④.

Guideline

Screw, front brake caliper	M8	25 Nm (18.4 lbf ft) Loctite®243™
----------------------------	----	--

- Mount the cable tie.
- Position the brake line, wiring harness, and clamp. Mount and tighten screws ⑤.

Finishing work

- Install the front wheel. 🛠️ (📖 p. 114)
- Install the headlight mask with the headlight. (📖 p. 126)
- Check the headlight setting. (📖 p. 127)



12.9 Removing the lower triple clamp 🛠️ (EXC-F EU, XCF-W)

Preparatory work

- Remove the headlight mask with the headlight. (📖 p. 125)
- Raise the motorcycle with the lift stand. (📖 p. 63)
- Remove the front wheel. 🛠️ (📖 p. 113)
- Remove the fork legs. 🛠️ (📖 p. 65)
- Remove front fender. (📖 p. 74)
- Remove the handlebar cushion.

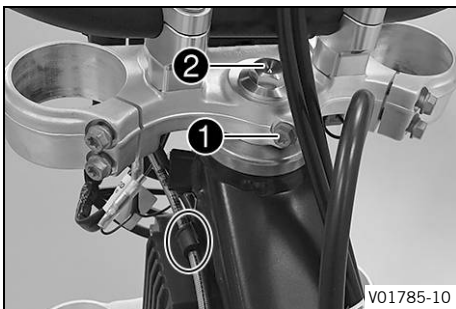

Main work

- Open the cable holder in front of the left radiator and detach the wiring harness.
- Loosen screw ①.
- Remove screw ②.
- Take off the upper triple clamp with the handlebar and hang them to the side.

i Info

Cover the components to protect them against damage. Do not kink the cables and lines.

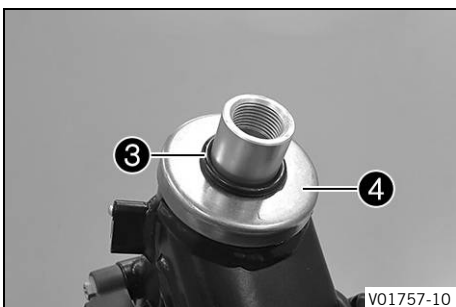

- Remove O-ring ③ and protective ring ④.
- Take off the lower triple clamp with the steering stem.
- Remove the upper steering head bearing.



12.10 Removing the lower triple clamp (EXC-F SIX DAYS EU)

Preparatory work

- Remove the headlight mask with the headlight. (📖 p. 125)
- Raise the motorcycle with the lift stand. (📖 p. 63)
- Remove the front wheel. (📖 p. 113)
- Remove the fork legs. (📖 p. 65)
- Remove front fender. (📖 p. 74)
- Remove the handlebar cushion.

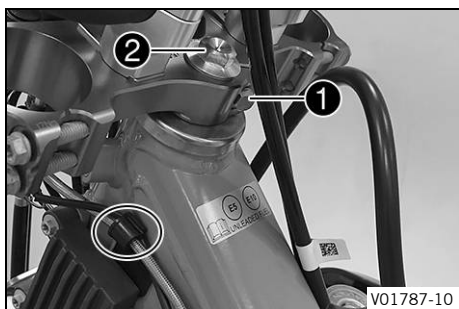

Main work

- Open the cable holder in front of the left radiator and detach the wiring harness.
- Remove screw 1.
- Remove screw 2.
- Take off the upper triple clamp with the handlebar and hang them to the side.

Info

Cover the components to protect them against damage. Do not kink the cables and lines.

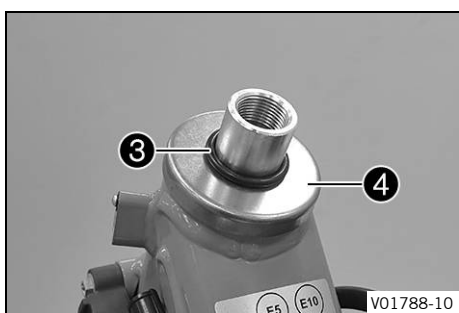

- Remove O-ring 3 and protective ring 4.
- Take off the lower triple clamp with the steering stem.
- Remove the upper steering head bearing.

12.11 Installing the lower triple clamp (EXC-F EU, XCF-W)

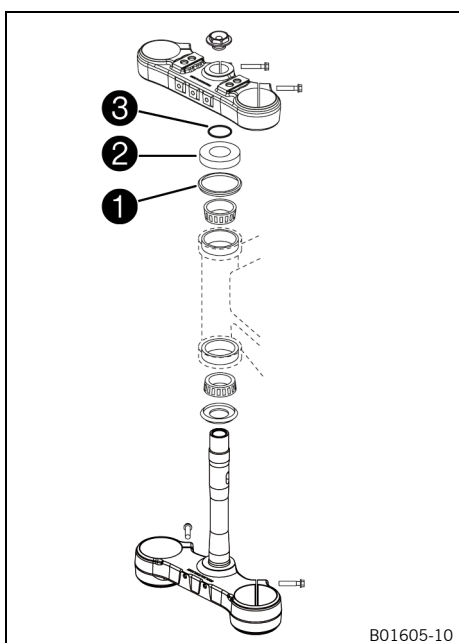

Main work

- Clean the bearing and sealing elements, check for damage, and grease.

High viscosity grease (📖 p. 166)

- Insert the lower triple clamp with the steering stem. Mount upper steering head bearing.
- Check whether upper steering head seal 1 is correctly positioned.
- Slide on protective ring 2 and O-ring 3.

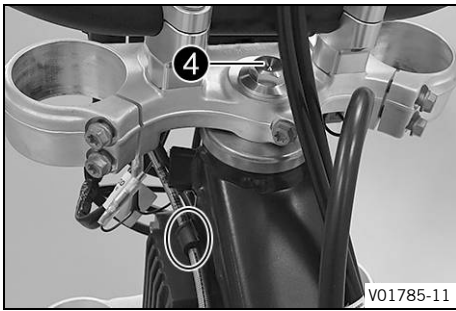

V01785-11

- Position the upper triple clamp with the handlebar.
- Mount screw ④, but do not tighten yet.
- Secure the wiring harness and the clutch line with the cable holder.

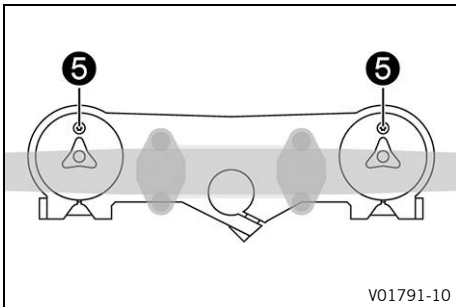

V01791-10

- Position the fork legs.
- ✓ Bleeder screws ⑤ are positioned toward the front.



Info

The rebound damping is located in right fork leg **REB** (red adjuster). The compression damping is located in left fork leg **COMP** (white adjuster).

Grooves are milled into the side of the upper end of the fork legs. The second milled groove (from the top) must be flush with the upper edge of the upper triple clamp.

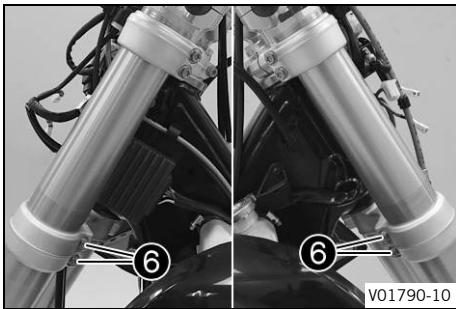

V01790-10

- Tighten screws ⑥.

Guideline

Screw, top triple clamp	M8	20 Nm (14.8 lbf ft)
-------------------------	----	---------------------

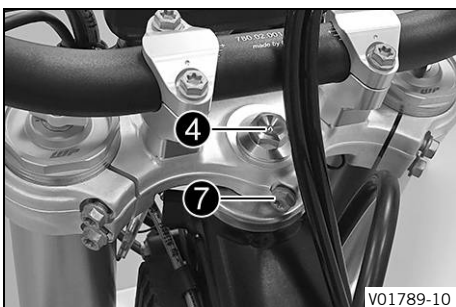

V01789-10

- Tighten screw ④.

Guideline

Screw, top steering head	M20x1.5	12 Nm (8.9 lbf ft)
--------------------------	---------	--------------------

- Tighten screw ⑦.

Guideline

Screw, top steering stem	M8	20 Nm (14.8 lbf ft)
--------------------------	----	---------------------

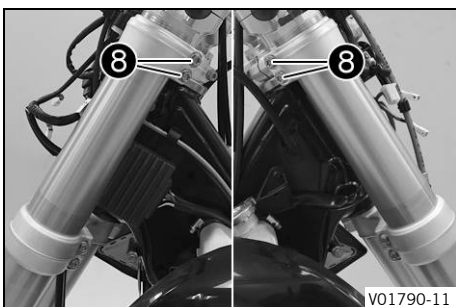

V01790-11

- Tighten screws ⑧.

Guideline

Screw, top triple clamp	M8	20 Nm (14.8 lbf ft)
-------------------------	----	---------------------

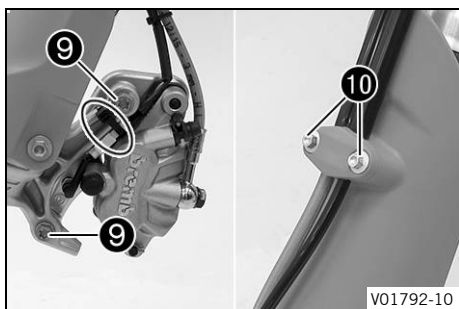

- Position the brake caliper, and mount and tighten screws **9**.

Guideline

Screw, front brake caliper	M8	25 Nm (18.4 lbf ft) Loctite®243™
----------------------------	----	--

- Mount the cable ties.
- Position the brake line, the wiring harness, and the clamp. Mount and tighten screws **10**.

Finishing work

- Mount the handlebar cushion.
- Install front fender. (📖 p. 75)
- Install the front wheel. 🛠️ (📖 p. 114)
- Install the headlight mask with the headlight. (📖 p. 126)
- Check that the wiring harness, throttle cables, and brake and clutch lines can move freely and are routed correctly.
- Check steering head bearing play. (📖 p. 72)
- Remove the motorcycle from the lift stand. (📖 p. 63)
- Check the headlight setting. (📖 p. 127)

12.12 Installing the lower triple clamp 🛠️ (EXC-F SIX DAYS EU)

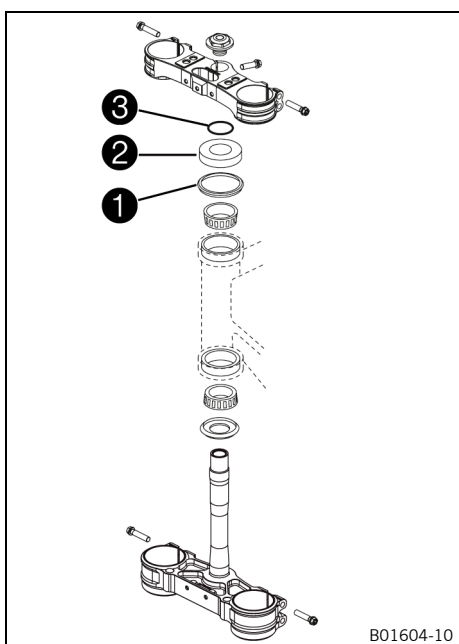

Main work

- Clean the bearing and sealing elements, check for damage, and grease.

High viscosity grease (📖 p. 166)

- Position the lower triple clamp with the steering stem. Mount upper steering head bearing.
- Check whether upper steering head seal **1** is correctly positioned.
- Mount protective ring **2** and O-ring **3**.

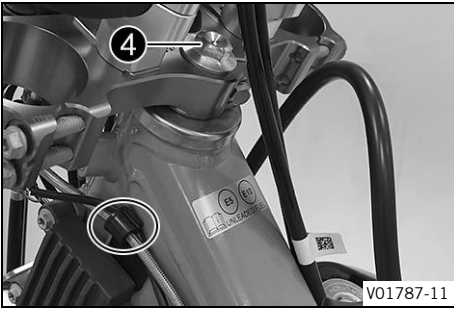

- Position the upper triple clamp with the handlebar.
- Mount screw **4**, but do not tighten yet.
- Secure the wiring harness and the clutch line with the cable holder.

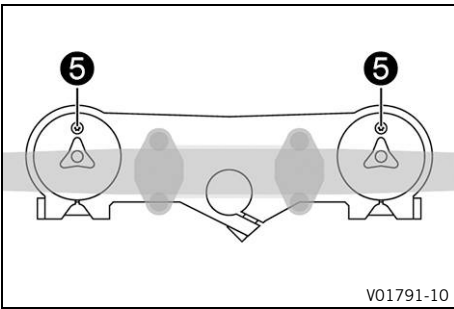

- Position the fork legs.
- ✓ Bleeder screws **5** are positioned toward the front.

i Info
 The rebound damping is located in right fork leg **REB** (red adjuster). The compression damping is located in left fork leg **COM** (white adjuster).
 Grooves are milled into the side of the upper end of the fork legs. The second milled groove (from the top) must be flush with the upper edge of the upper triple clamp.

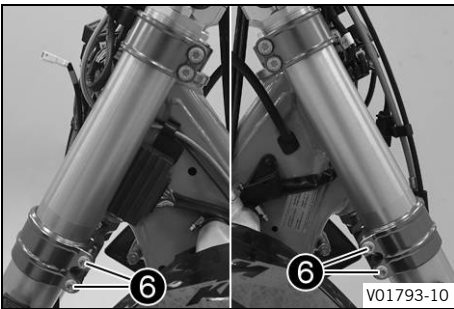

- Tighten screws **6**.

Guideline

Screw, bottom triple clamp	M8	15 Nm (11.1 lbf ft)
----------------------------	----	---------------------

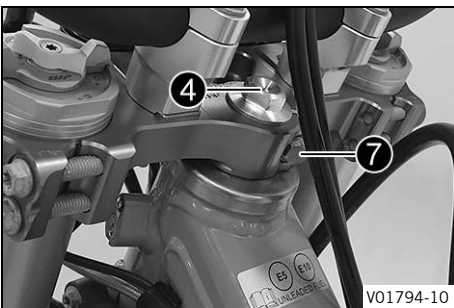

- Tighten screw **4**.

Guideline

Screw, top steering head	M20x1.5	12 Nm (8.9 lbf ft)
--------------------------	---------	--------------------

- Mount and tighten screw **7**.

Guideline

Screw, top steering stem	M8	17 Nm (12.5 lbf ft) Loctite®243™
--------------------------	----	--

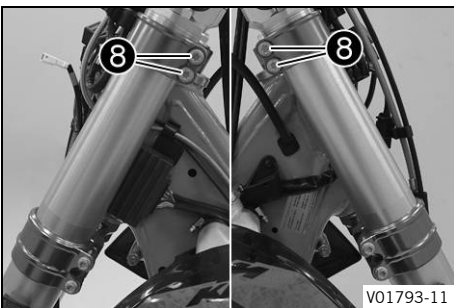

- Tighten screws **8**.

Guideline

Screw, top triple clamp	M8	17 Nm (12.5 lbf ft)
-------------------------	----	---------------------

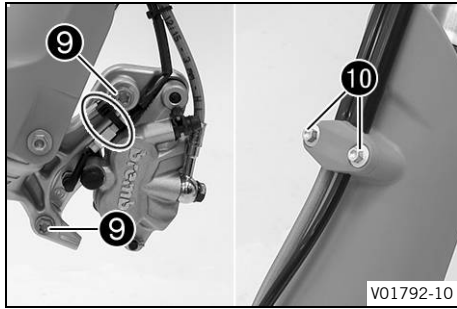

- Position the brake caliper, and mount and tighten screws 9.

Guideline

Screw, front brake caliper	M8	25 Nm (18.4 lbf ft) Loctite®243™
----------------------------	----	--

- Mount the cable ties.
- Position the brake line, the wiring harness, and the clamp. Mount and tighten screws 10.

Finishing work

- Mount the handlebar cushion.
- Install front fender. (📖 p. 75)
- Install the front wheel. 🛠️ (📖 p. 114)
- Install the headlight mask with the headlight. (📖 p. 126)
- Check that the wiring harness, throttle cables, and brake and clutch lines can move freely and are routed correctly.
- Check steering head bearing play. (📖 p. 72)
- Remove the motorcycle from the lift stand. (📖 p. 63)
- Check the headlight setting. (📖 p. 127)

12.13 Checking steering head bearing play



Warning

Danger of accidents Incorrect steering head bearing play impairs the handling characteristic and damages components.

- Correct incorrect steering head bearing play immediately. (Your authorized KTM workshop will be glad to help.)



Info

If the vehicle is operated for a lengthy period with play in the steering head bearing, the bearings and the bearing seats in the frame can become damaged over time.

Preparatory work

- Raise the motorcycle with the lift stand. (📖 p. 63)

Main work

- Move the handlebar to the straight-ahead position. Move the fork legs to and fro in the direction of travel.

Play should not be detectable on the steering head bearing.

- » If there is detectable play:

(EXC-F EU, XCF-W)

- Adjust the steering head bearing play. 🛠️ (📖 p. 73)

(EXC-F SIX DAYS EU)

- Adjust the steering head bearing play. 🛠️ (📖 p. 73)

- Move the handlebar to and fro over the entire steering range.

It must be possible to move the handlebar easily over the entire steering range. There should be no detectable detent positions.

- » If detent positions are detected:

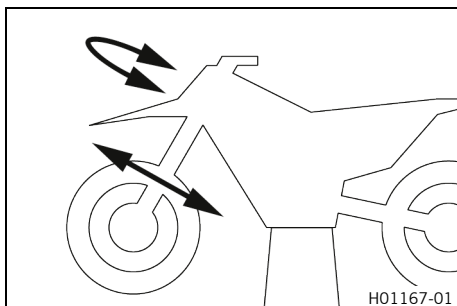

(EXC-F EU, XCF-W)

- Adjust the steering head bearing play. 🛠️ (📖 p. 73)

(EXC-F SIX DAYS EU)

- Adjust the steering head bearing play. 🛠️ (📖 p. 73)
- Check the steering head bearing and replace if necessary.

Finishing work

- Remove the motorcycle from the lift stand. (📖 p. 63)



12.14 Adjusting the steering head bearing play 🛠️ (EXC-F EU, XCF-W)

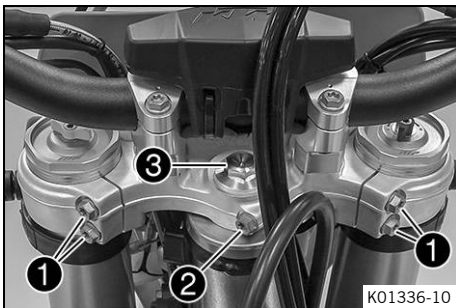

Preparatory work

- Raise the motorcycle with the lift stand. (📖 p. 63)

Main work

- Loosen screws ① and ②.
- Loosen and retighten screw ③.

Guideline

Screw, top steering head	M20x1.5	12 Nm (8.9 lbf ft)
--------------------------	---------	--------------------

- Using a plastic hammer, tap lightly on the upper triple clamp to avoid stresses.

- Tighten screws ①.

Guideline

Screw, top triple clamp	M8	20 Nm (14.8 lbf ft)
-------------------------	----	---------------------

- Tighten screw ②.

Guideline

Screw, top steering stem	M8	20 Nm (14.8 lbf ft)
--------------------------	----	---------------------

Finishing work

- Check steering head bearing play. (📖 p. 72)
- Remove the motorcycle from the lift stand. (📖 p. 63)



12.15 Adjusting the steering head bearing play 🛠️ (EXC-F SIX DAYS EU)

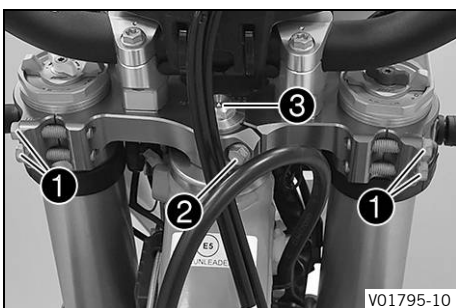

Preparatory work

- Raise the motorcycle with the lift stand. (📖 p. 63)

Main work

- Loosen screws ①.
- Remove screw ②.
- Loosen and retighten screw ③.

Guideline

Screw, top steering head	M20x1.5	12 Nm (8.9 lbf ft)
--------------------------	---------	--------------------

- Using a plastic hammer, tap lightly on the upper triple clamp to avoid stresses.

- Tighten screws ①.

Guideline

Screw, top triple clamp	M8	17 Nm (12.5 lbf ft)
-------------------------	----	---------------------

- Mount and tighten screw ❷.

Guideline

Screw, top steering stem	M8	17 Nm (12.5 lbf ft) Loctite®243™
--------------------------	----	--

Finishing work

- Check steering head bearing play. (📖 p. 72)
- Remove the motorcycle from the lift stand. (📖 p. 63)

12.16 Lubricating the steering head bearing 🛠️

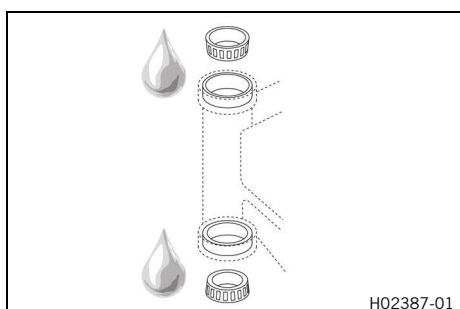

(EXC-F EU, XCF-W)

- Remove the lower triple clamp. 🛠️ (📖 p. 67)
- Install the lower triple clamp. 🛠️ (📖 p. 68)



Info

The steering head bearing is cleaned and lubricated in the course of removal and installation of the lower triple clamp.

(EXC-F SIX DAYS EU)

- Remove the lower triple clamp. 🛠️ (📖 p. 68)
- Install the lower triple clamp. 🛠️ (📖 p. 70)



Info

The steering head bearing is cleaned and lubricated in the course of removal and installation of the lower triple clamp.

12.17 Removing front fender

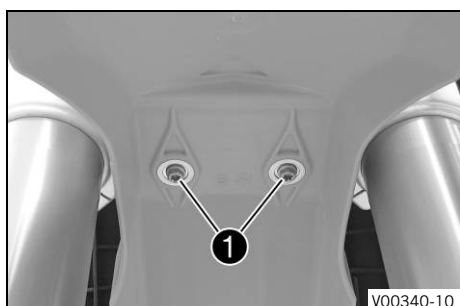

Preparatory work

- Remove the headlight mask with the headlight. (📖 p. 125)

Main work

(EXC-F EU, XCF-W)

- Remove screws ❶.

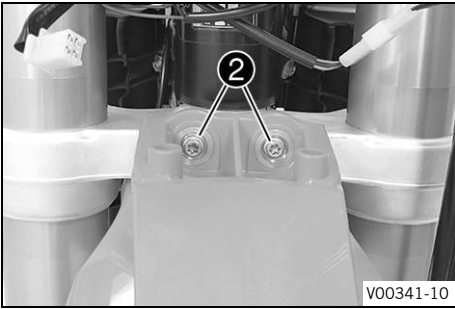

- Remove screws ②. Take off front fender.

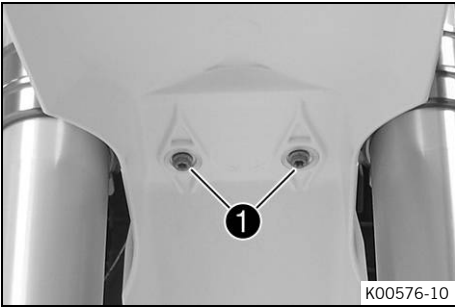

(EXC-F SIX DAYS EU)

- Remove screws ①.

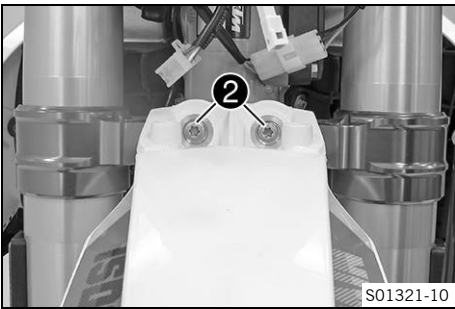

- Remove screws ②. Take off front fender.

12.18 Installing front fender

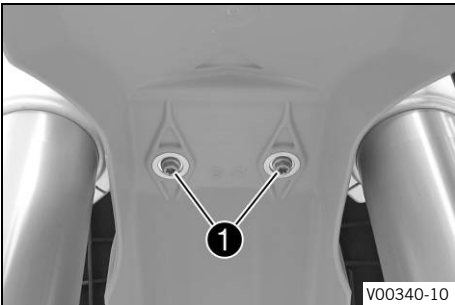

Main work

(EXC-F EU, XCF-W)

- Position front fender. Mount and tighten screws ①.

Guideline

Remaining screws, chassis	M6	10 Nm (7.4 lbf ft)
---------------------------	----	--------------------

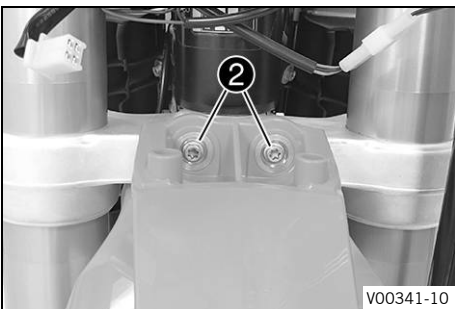

- Mount and tighten screws ②.

Guideline

Remaining screws, chassis	M6	10 Nm (7.4 lbf ft)
---------------------------	----	--------------------

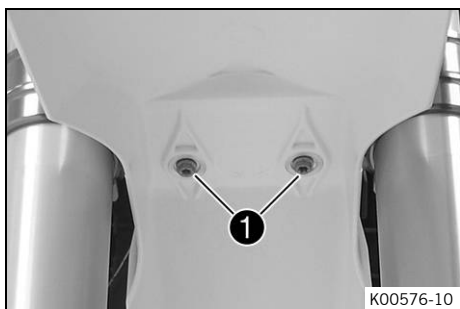

(EXC-F SIX DAYS EU)

- Position front fender. Mount and tighten screws 1.

Guideline

Remaining screws, chassis	M6	10 Nm (7.4 lbf ft)
---------------------------	----	--------------------

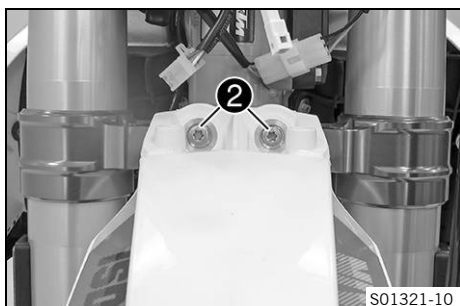

- Mount and tighten screws 2.

Guideline

Remaining screws, chassis	M6	10 Nm (7.4 lbf ft)
---------------------------	----	--------------------

Finishing work

- Install the headlight mask with the headlight. (📖 p. 126)
- Check the headlight setting. (📖 p. 127)

12.19 Removing the shock absorber ↩

Preparatory work

- Raise the motorcycle with the lift stand. (📖 p. 63)

Main work

- Remove screw 1 and lower the rear wheel with the link fork as far as possible without blocking the rear wheel. Secure the rear wheel in this position.
- Remove screw 2, push splash protector 3 to the side, and remove the shock absorber.

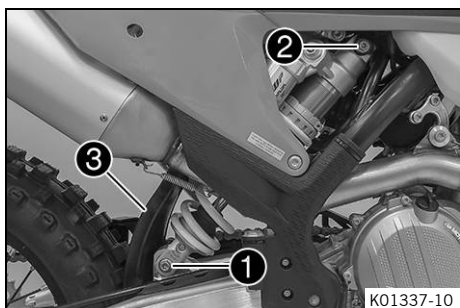

12.20 Installing the shock absorber ↩

Main work

- Push splash protector 1 to the side and position the shock absorber. Mount and tighten screw 2.

Guideline

Screw, top shock absorber	M12	80 Nm (59 lbf ft) Loctite®2701™
---------------------------	-----	---

- Mount and tighten screw 3.

Guideline

Screw, bottom shock absorber	M12	80 Nm (59 lbf ft) Loctite®2701™
------------------------------	-----	---

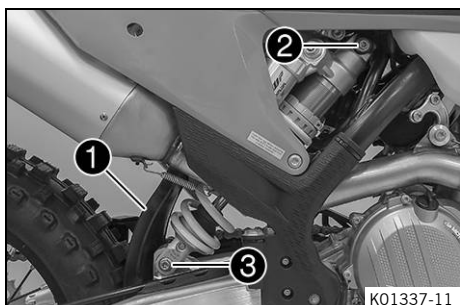



Info

The heim joint for the shock absorber on the link fork is Teflon coated. It must not be lubricated with grease, nor with any other lubricants. Lubricants dissolve the Teflon coating, thereby drastically reducing the service life.

Finishing work

- Remove the motorcycle from the lift stand. (📖 p. 63)



12.21 Removing the seat

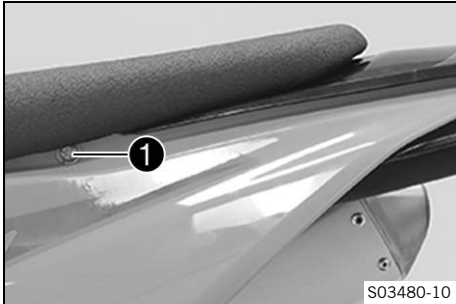

- Remove screw ① on the left side.

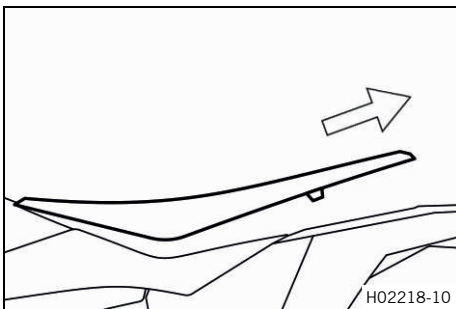

- Raise the rear of the seat, pull the seat back, and lift it off.



12.22 Mounting the seat

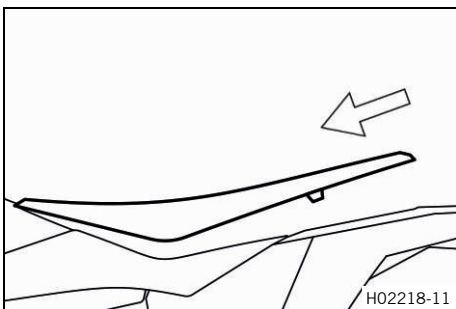

- Mount the front of the seat on the collar bushings of the fuel tank, lower the seat at the rear, and push the seat forward.
- Make sure the seat is locked in correctly.

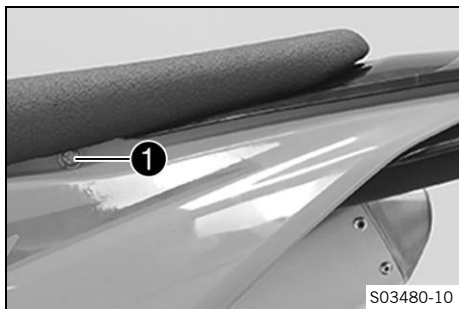

- Mount and tighten screw **1**.

Guideline

Remaining screws, chassis	M6	10 Nm (7.4 lbf ft)
---------------------------	----	--------------------

12.23 Removing the air filter box cover

Condition

The air filter box cover is secured.

- Remove the seat. (📖 p. 77)
- Remove screw **1**.

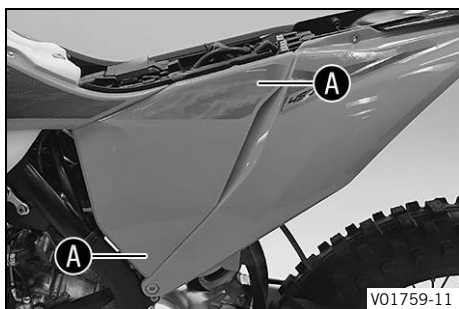

- Pull off the air filter box cover in area **A** laterally and take it off at the front.

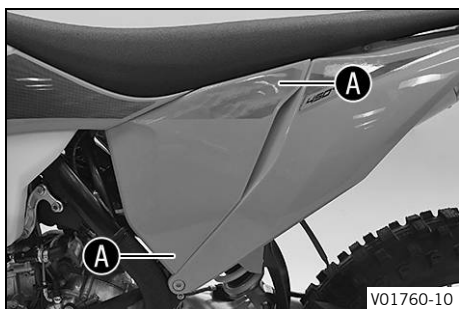

Condition

The air filter box cover is not secured.

- Pull off the air filter box cover in area **A** laterally and take it off at the front.

12.24 Installing the air filter box cover

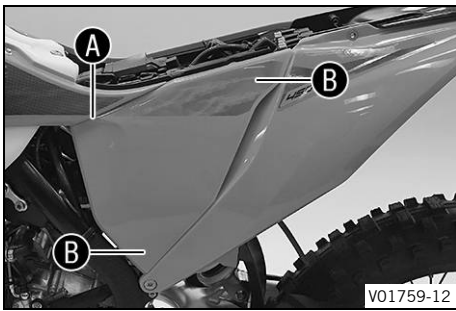

Condition

The air filter box cover is secured.

- Insert the air filter box cover in area **A** and clip it into area **B**.

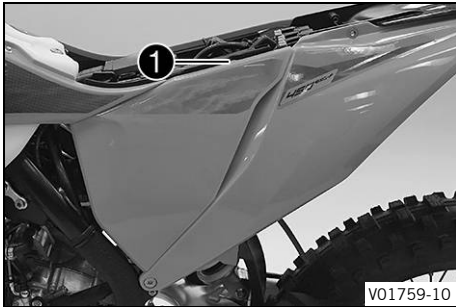

- Mount and tighten screw **1**.

Guideline

Screw, air filter box cover	EJOT PT® K60x20-Z	3 Nm (2.2 lbf ft)
-----------------------------	-----------------------------	-------------------

- Mount the seat. (📖 p. 77)

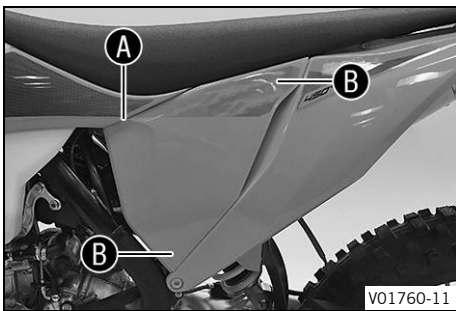

Condition

The air filter box cover is not secured.

- Insert the air filter box cover in area **A** and clip it into area **B**.

12.25 Removing the air filter

Note

Engine damage Unfiltered intake air has a negative effect on the service life of the engine.

Dust and dirt will enter the engine without an air filter.

- Only operate the vehicle if it is equipped with an air filter.



Note

Environmental hazard Hazardous substances cause environmental damage.

- Dispose of oils, grease, filters, fuel, cleaning agents, brake fluid, etc., correctly and in compliance with the applicable regulations.

Preparatory work

- Remove the air filter box cover. (📖 p. 78)

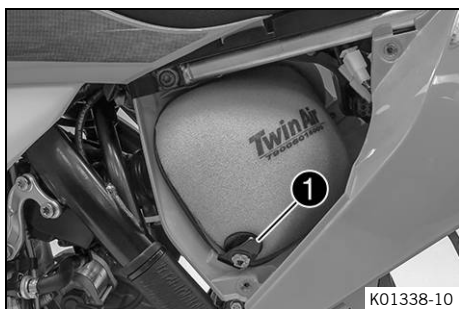

Main work

- Detach retaining tab 1. Remove air filter with air filter support.
- Remove air filter from air filter support.

12.26 Installing the air filter

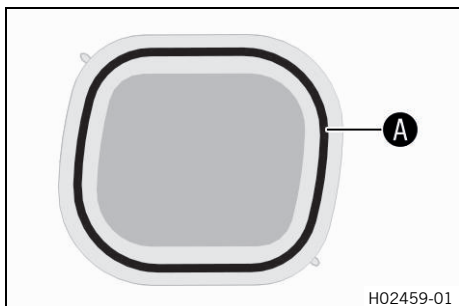

Main work

- Mount the clean air filter on the air filter support.
- Grease the air filter in area A.

Long-life grease (📖 p. 166)

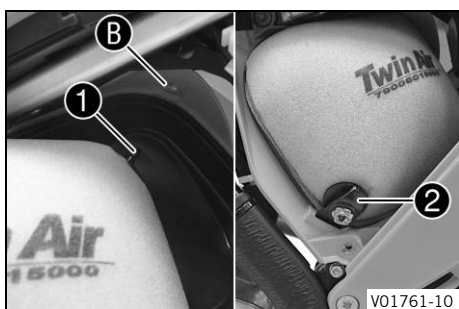

- Insert air filter and position retaining pin 1 in bushing B.
- ✓ The air filter is correctly positioned.
- Secure the bottom retaining pin with holding tab 2.

Info

If the air filter is not mounted correctly, dust and dirt may enter the engine and result in damage.

Finishing work

- Install the air filter box cover. (📖 p. 79)

12.27 Cleaning the air filter and air filter box



Note

Environmental hazard Hazardous substances cause environmental damage.

- Dispose of oils, grease, filters, fuel, cleaning agents, brake fluid, etc., correctly and in compliance with the applicable regulations.



Info

Do not clean the air filter with fuel or petroleum since these substances attack the foam.

Preparatory work

- Remove the air filter box cover. (📖 p. 78)
- Remove the air filter. 🗑️ (📖 p. 79)



F01027-01

Main work

- Wash the air filter thoroughly in special cleaning liquid and allow it to dry properly.

Air filter cleaner (🗉 p. 166)

Info

Only press the air filter to dry it, never wring it out.

- Oil the dry air filter with a high-grade air filter oil.

Oil for foam air filter (🗉 p. 166)

- Clean the air filter box.
- Check the intake flange for damage and looseness.

Finishing work

- Install the air filter. 🗉 (🗉 p. 80)
- Install the air filter box cover. (🗉 p. 79)

12.28 Preparing air filter box cover for securing 🗉

Preparatory work

- Remove the air filter box cover. (🗉 p. 78)

Main work

- Drill a hole at marking **A**.

Guideline

Diameter	6 mm (0.24 in)
----------	----------------

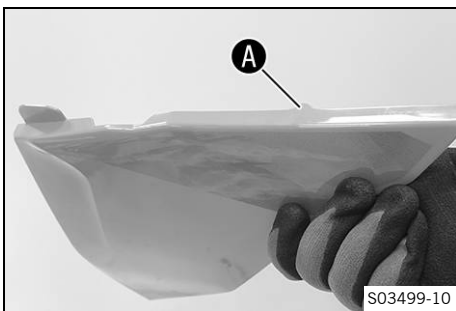

S03499-10

Finishing work

- Install the air filter box cover. (🗉 p. 79)

12.29 Removing the main silencer

Warning

Danger of burns The exhaust system gets very hot when the vehicle is driven.

- Allow the exhaust system to cool down before performing any work on the vehicle.

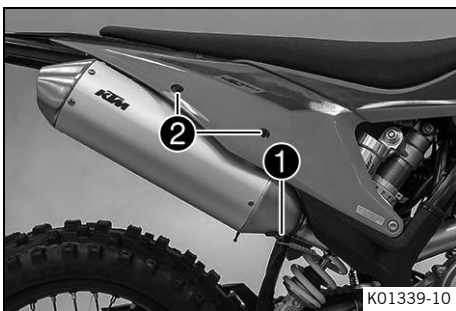

K01339-10

(All EU models)

- Detach spring **1**.

Spring hook (50305017000C1)

- Remove screws **2** and take off the main silencer with the catalytic converter.

(XCF-W)

- Detach spring **1**.

Spring hook (50305017000C1)

- Remove screws ② and take off the main silencer.

12.30 Installing the main silencer

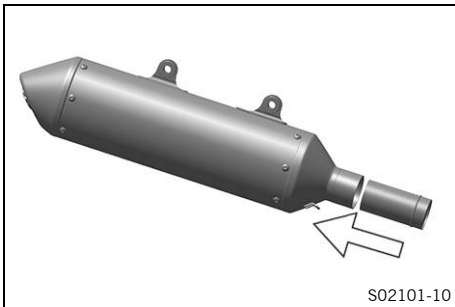

(All EU models)

- Position the catalytic converter in the main silencer.

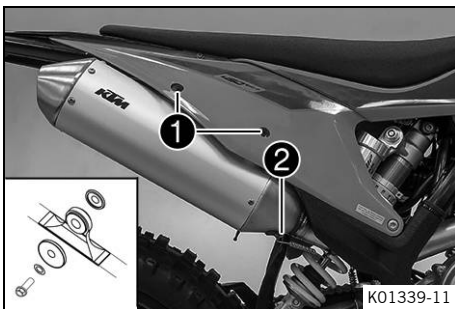

- Position the main silencer. Mount screws ①, but do not tighten yet.
- Attach spring ②.

Spring hook (50305017000C1)

- Tighten screws ①.

Guideline

Remaining screws, chassis	M6	10 Nm (7.4 lbf ft)
---------------------------	----	--------------------

12.31 Cleaning the spark arrestor (XCF-W)



Warning

Danger of burns The exhaust system gets very hot when the vehicle is driven.

- Allow the exhaust system to cool down before performing any work on the vehicle.



Info

Soot particles accumulate on the screen of the spark arrestor over time. This changes the performance characteristics.

Preparatory work

- Remove main silencer. (📖 p. 81)

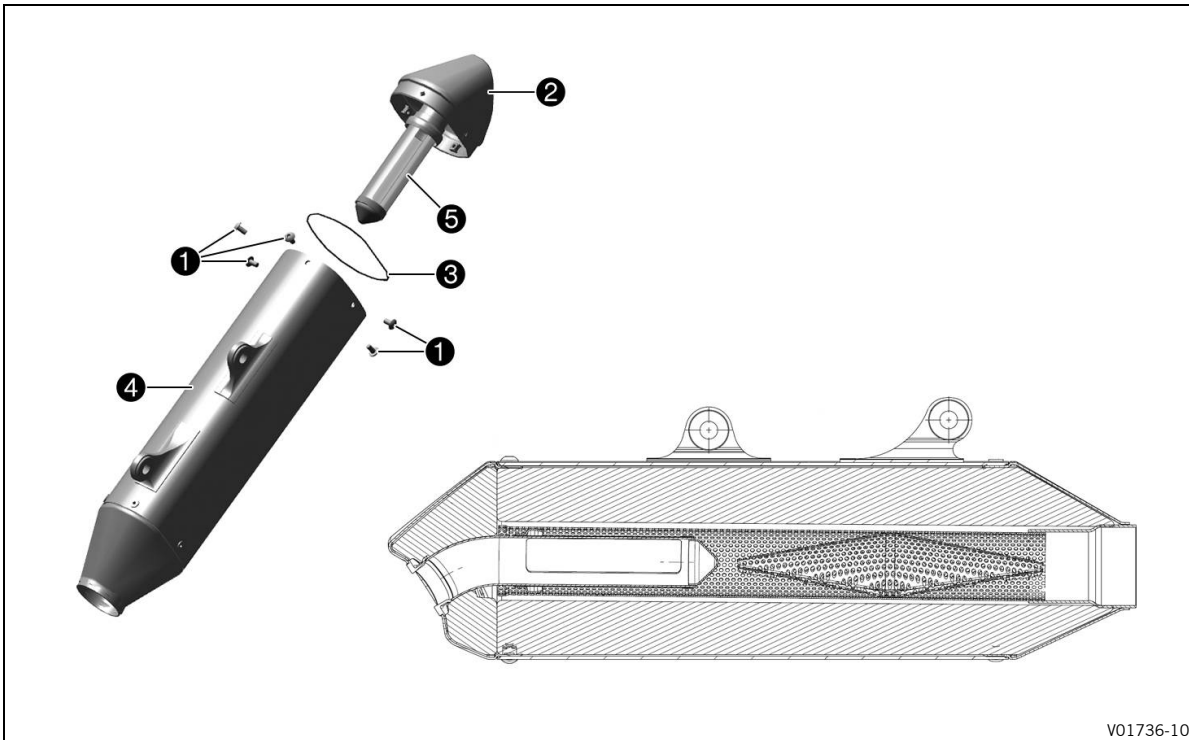

V01736-10

Main work

- Remove screws ① and take off silencer cap ② with O-ring ③.



Info

Do not remove the glass fiber yarn filling.



Caution

Danger to health Soot particles irritate the eyes and mucuous membranes.

- Wear suitable breathing and eye protection when cleaning the main silencer and carbon screen.

- Clean main silencer sleeve ④ and screen ⑤ of the spark arrestor with compressed air.
- Mount new O-ring ③ on silencer cap ②.
- Position silencer cap ②. Mount and tighten screws ①.

Guideline

Screws on main silencer	M5	7 Nm (5.2 lbf ft)
-------------------------	----	-------------------

Finishing work

- Install the main silencer. (📖 p. 82)



12.32 Changing the glass fiber yarn filling of the main silencer ↗



Warning

Danger of burns The exhaust system gets very hot when the vehicle is driven.

- Allow the exhaust system to cool down before performing any work on the vehicle.



Info

Over time, the fibers of the glass fiber yarn filling escape and the damper "burns" out. Not only is the noise level higher, but the performance characteristics change.

Preparatory work

- Remove main silencer. (🔧 p. 81)

Main work

(All EU models)

- Remove screws ①.
- Take off silencer cap ② with O-ring ③.
- Remove the old glass fiber yarn filling.
- Clean the parts that need to be reinstalled and check for damage.
- Mount the new glass fiber yarn filling ④ in the main silencer.
- Mount the O-ring on the silencer cap.
- Position the silencer cap.
- Mount and tighten all of the screws.

Guideline

Screws on main silencer	M5	7 Nm (5.2 lbf ft)
-------------------------	----	-------------------

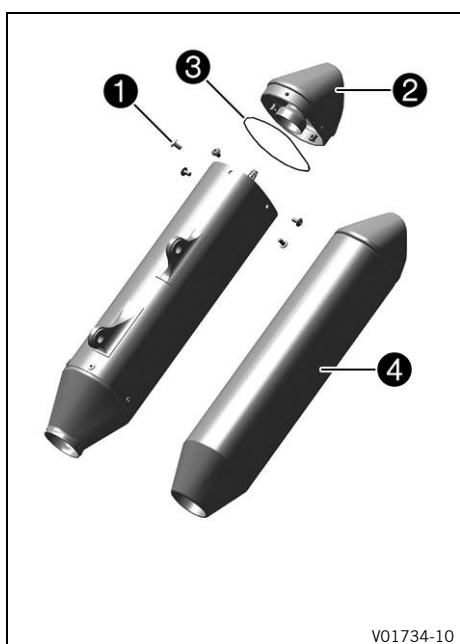

(XCF-W)

- Remove screws ①.
- Take off silencer cap ② with O-ring ③.
- Remove the old glass fiber yarn filling.
- Clean the parts that need to be reinstalled and check for damage.
- Mount the new glass fiber yarn filling ④ in the main silencer.
- Mount the O-ring on the silencer cap.
- Position the silencer cap.
- Mount and tighten all of the screws.

Guideline

Screws on main silencer	M5	7 Nm (5.2 lbf ft)
-------------------------	----	-------------------

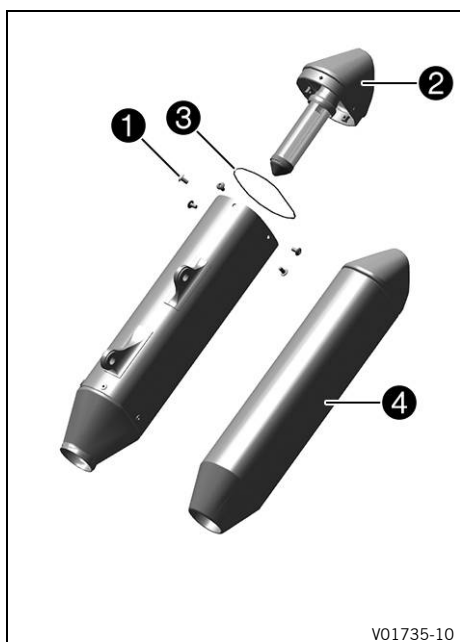

Finishing work

- Install the main silencer. (🔧 p. 82)



12.33 Removing the fuel tank ↩



Danger

Fire hazard Fuel is highly flammable.

The fuel in the fuel tank expands when warm and can escape if overfilled.

- Do not fuel the vehicle in the vicinity of open flames or lit cigarettes.
- Switch off the engine for refueling.
- Make sure that no fuel is spilled; particularly not on hot parts of the vehicle.
- If any fuel is spilled, wipe it off immediately.
- Observe the specifications for refueling.



Warning

Danger of poisoning Fuel is poisonous and a health hazard.

- Avoid skin, eye and clothing contact with fuel.
- Immediately consult a doctor if you swallow fuel.
- Do not inhale fuel vapors.
- In case of skin contact, rinse the affected area with plenty of water.
- Rinse the eyes thoroughly with water, and consult a doctor in case of fuel contact with the eyes.
- Change your clothing in case of fuel spills on them.
- Keep fuels correctly in a suitable canister, and out of the reach of children.

Preparatory work

- Remove the seat. (🔧 p. 77)

Main work

- Unplug connector ❶ of the fuel pump.
- Clean quick release coupling ❷ thoroughly with compressed air.



Info

Under no circumstances should dirt enter into the fuel line. Dirt in the fuel line clogs the injection valve!

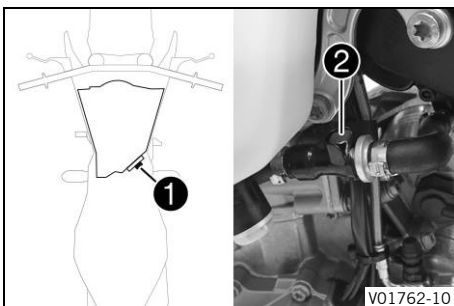

V01762-10

- Disconnect the quick release coupling.



Info

Remaining fuel may flow out of the fuel line.

- Mount wash cap set ❸.

Wash cap set (81212016100)

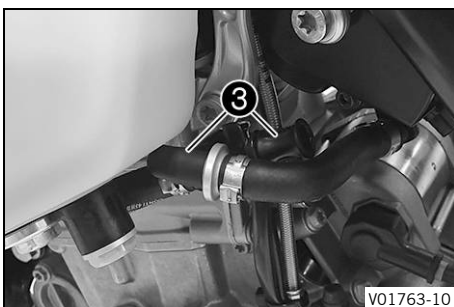

V01763-10

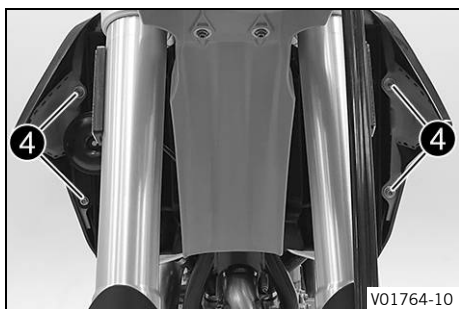

(All EU models)

- Remove screws 4.
- Hang the horn and horn bracket to one side.



(XCF-W)

- Remove screws 4.



- Remove screw 5 with the rubber bushing.
- Remove the hose from the fuel tank breather.

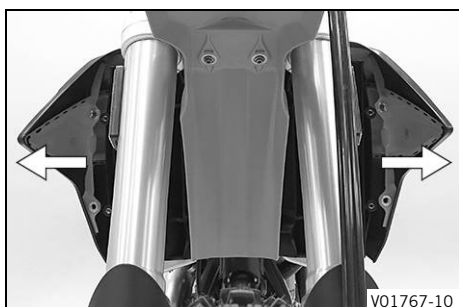

- Pull both spoilers laterally off the radiator and lift off the fuel tank.

12.34 Installing the fuel tank ↩



Danger

Fire hazard Fuel is highly flammable.

The fuel in the fuel tank expands when warm and can escape if overfilled.

- Do not fuel the vehicle in the vicinity of open flames or lit cigarettes.
- Switch off the engine for refueling.
- Make sure that no fuel is spilled; particularly not on hot parts of the vehicle.
- If any fuel is spilled, wipe it off immediately.
- Observe the specifications for refueling.



Warning

Danger of poisoning Fuel is poisonous and a health hazard.

- Avoid skin, eye and clothing contact with fuel.
- Immediately consult a doctor if you swallow fuel.
- Do not inhale fuel vapors.
- In case of skin contact, rinse the affected area with plenty of water.
- Rinse the eyes thoroughly with water, and consult a doctor in case of fuel contact with the eyes.
- Change your clothing in case of fuel spills on them.

Main work

- Check the throttle cable routing. (🔧 p. 93)
- Position the fuel tank and fit the two spoilers to the sides in front of the radiator bracket.
- Make sure that no cables or throttle cables are trapped or damaged.

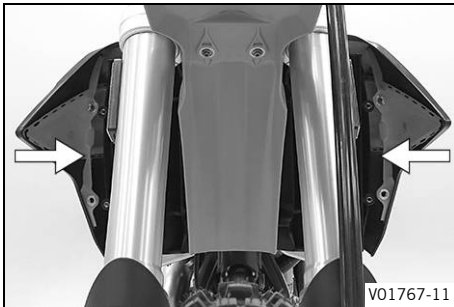

- Attach the fuel tank breather hose.
- Mount and tighten screw ❶ with the rubber bushing.

Guideline

Remaining screws, chassis	M6	10 Nm (7.4 lbf ft)
---------------------------	----	--------------------

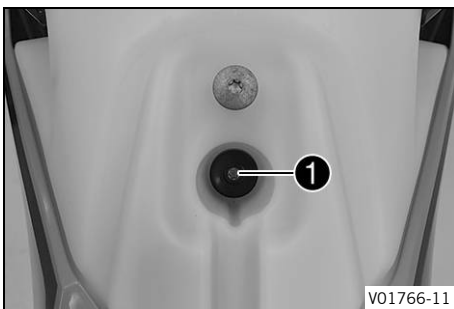

(All EU models)

- Position the horn with the horn bracket.
- Mount and tighten screws ❷.

Guideline

Remaining screws, chassis	M6	10 Nm (7.4 lbf ft)
---------------------------	----	--------------------



(XCF-W)

- Mount and tighten screws ❷.

Guideline

Remaining screws, chassis	M6	10 Nm (7.4 lbf ft)
---------------------------	----	--------------------



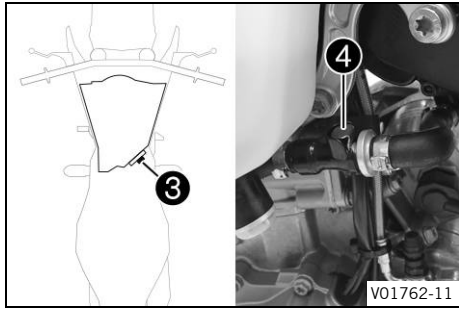

- Plug in connector ③ for the fuel pump.
- Remove the wash cap set.
- Clean the quick release coupling thoroughly with compressed air.

i Info

Under no circumstances should dirt enter into the fuel line. Dirt in the fuel line clogs the injection valve!

- Spray silicone spray onto a lint-free cleaning cloth and lightly lubricate the O-ring of the quick-release coupling.

Silicone spray (📖 p. 167)

- Join quick release coupling ④.

i Info

Route the cable and fuel line at a safe distance from the exhaust system.

Finishing work

- Mount the seat. (📖 p. 77)

12.35 Checking for chain dirt accumulation

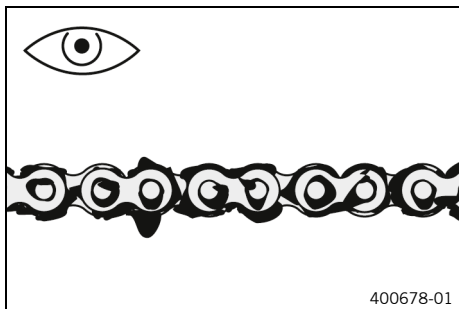

- Check the chain for coarse dirt accumulation.
 - » If the chain is very dirty:
 - Clean the chain. (📖 p. 88)

12.36 Cleaning the chain



Warning

Danger of accidents Lubricants on the tires reduces the road grip.

- Remove lubricants from the tires using a suitable cleaning agent.



Warning

Danger of accidents Oil or grease on the brake discs reduces the braking effect.

- Always keep the brake discs free of oil and grease.
- Clean the brake discs with brake cleaner when necessary.



Note

Environmental hazard Hazardous substances cause environmental damage.

- Dispose of oils, grease, filters, fuel, cleaning agents, brake fluid, etc., correctly and in compliance with the applicable regulations.



Info

The service life of the chain depends largely on its maintenance.

Preparatory work

- Raise the motorcycle with the lift stand. (📖 p. 63)

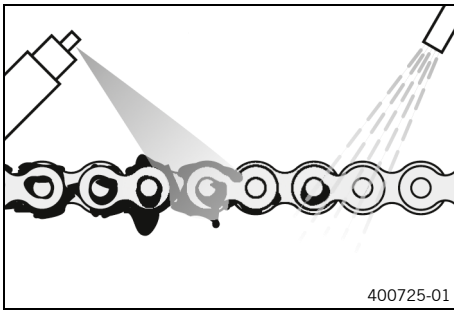

Main work

- Rinse off loose dirt with a soft jet of water.
- Remove old grease residue with chain cleaner.

Chain cleaner (📖 p. 166)

- After drying, apply chain spray.

Off-road chain spray (📖 p. 166)

Finishing work

- Remove the motorcycle from the lift stand. (📖 p. 63)



12.37 Checking the chain tension



Warning

Danger of accidents Incorrect chain tension damages components and results in accidents.

If the chain is tensioned too much, the chain, engine sprocket, rear sprocket, transmission and rear wheel bearings wear more quickly. Some components may break if overloaded.

If the chain is too loose, the chain may fall off the engine sprocket or the rear sprocket. As a result, the rear wheel locks or the engine will be damaged.

- Check the chain tension regularly.
- Set the chain tension in accordance with the specification.

Preparatory work

- Raise the motorcycle with the lift stand. (📖 p. 63)

Main work

- Pull the chain at the end of the chain sliding piece upward to measure chain tension **A**.

Info

Lower chain section **1** must be taut.

When the chain guard is mounted, it must be possible to pull up the chain at least to the point where it makes contact with chain guard **B**.

Chain wear is not always even, so you should repeat this measurement at different chain positions.

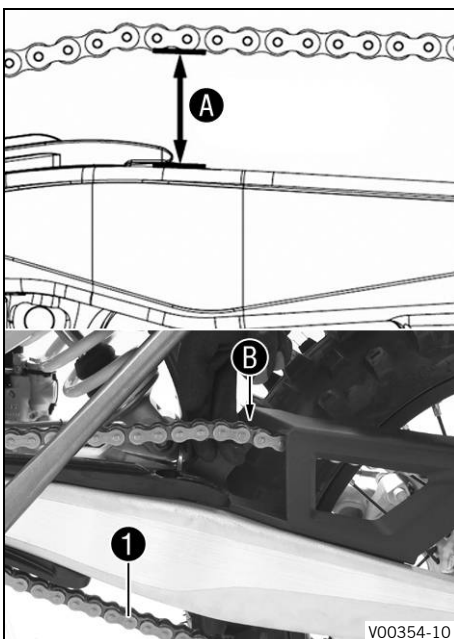

Chain tension	55 ... 58 mm (2.17 ... 2.28 in)
---------------	---------------------------------

- » If the chain tension does not meet the specification:
 - Adjust the chain tension. (📖 p. 90)

Finishing work

- Remove the motorcycle from the lift stand. (📖 p. 63)



12.38 Adjusting the chain tension



Warning

Danger of accidents Incorrect chain tension damages components and results in accidents.

If the chain is tensioned too much, the chain, engine sprocket, rear sprocket, transmission and rear wheel bearings wear more quickly. Some components may break if overloaded.

If the chain is too loose, the chain may fall off the engine sprocket or the rear sprocket. As a result, the rear wheel locks or the engine will be damaged.

- Check the chain tension regularly.
- Set the chain tension in accordance with the specification.

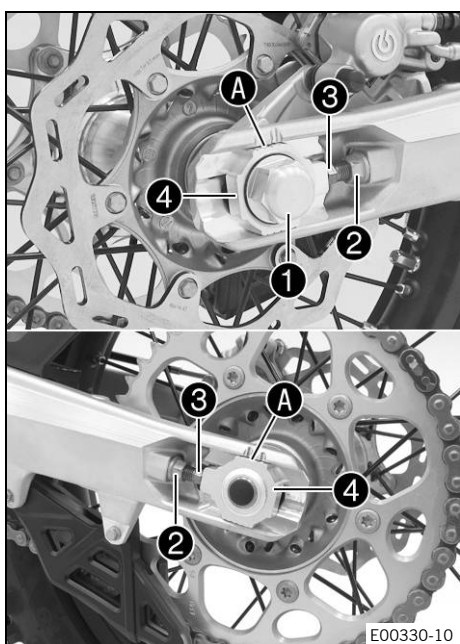

Preparatory work

- Raise the motorcycle with the lift stand. (📖 p. 63)
- Check the chain tension. (📖 p. 89)

Main work

- Loosen nut ①.
- Loosen nuts ②.
- Adjust the chain tension by turning adjusting screws ③ left and right.

Guideline

Chain tension	55 ... 58 mm (2.17 ... 2.28 in)
---------------	---------------------------------

Turn adjusting screws ③ on the left and right so that the markings on the left and right chain adjusters are in the same position relative to reference marks A. The rear wheel is then correctly aligned.

- Tighten nuts ②.
- Make sure that chain adjusters ④ are fitted correctly on adjusting screws ③.
- Tighten nut ①.

Guideline

Nut, rear wheel spindle	M20x1.5	80 Nm (59 lbf ft)
-------------------------	---------	-------------------



Info

The wide adjustment range of the chain adjusters (32 mm (1.26 in)) enables different secondary ratios with the same chain length.

Chain adjusters ④ can be turned by 180°.

Finishing work

- Remove the motorcycle from the lift stand. (📖 p. 63)

12.39 Checking the chain, rear sprocket, engine sprocket, and chain guide

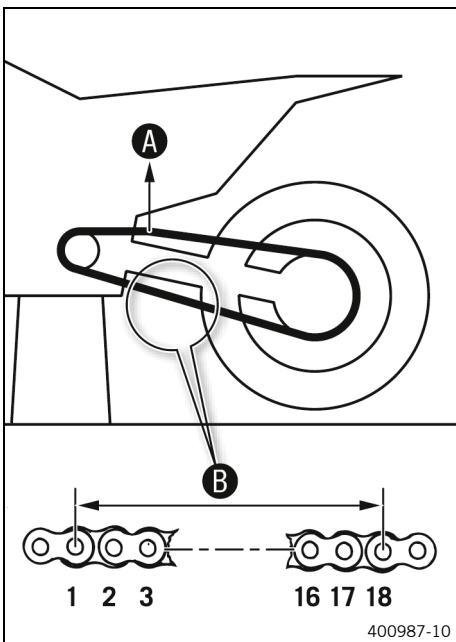
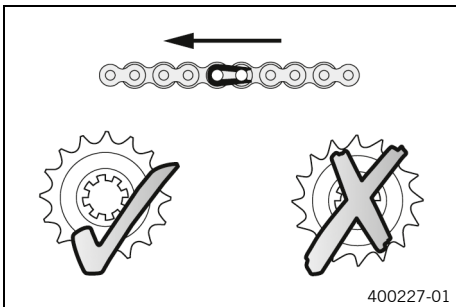

Preparatory work

- Raise the motorcycle with the lift stand. (📖 p. 63)

Main work

- Shift the transmission into neutral.
- Check the rear sprocket and engine sprocket for wear.
 - » If the rear sprocket and engine sprocket are worn:
 - Change the drivetrain kit. 🛠️

i Info

The engine sprocket, rear sprocket and chain should always be replaced together.

- Pull on the top section of the chain with the specified weight **A**.

Guideline

Weight of chain wear measurement	10 ... 15 kg (22 ... 33 lb.)
----------------------------------	------------------------------

- Measure distance **B** of 18 chain rollers in the lower chain section.

i Info

Chain wear is not always even, so you should repeat this measurement at different chain positions.

Maximum distance B from 18 chain rollers at the longest chain section	272 mm (10.71 in)
--	-------------------

- » If distance **B** is greater than the specified measurement:
 - Change the drivetrain kit. 🛠️

i Info

When a new chain is mounted, the rear sprocket and engine sprocket should also be changed. New chains wear out faster on old, worn sprockets.

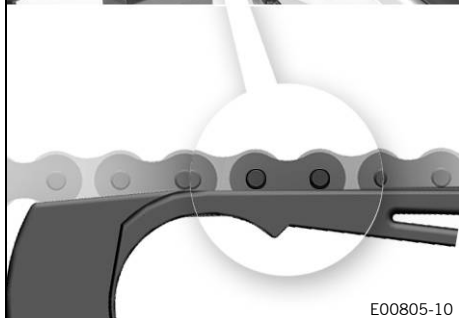
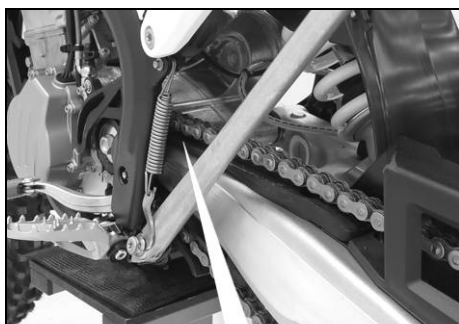

E00805-10

- Check the chain sliding guard for wear.
 - » If the lower edge of the chain pins is in line with, or below, the chain sliding guard:
 - Change the chain sliding guard. 🛠️
- Check that the chain sliding guard is firmly seated.
 - » If the chain sliding guard is loose:
 - Tighten the screws on the chain sliding guard.

Guideline

Screw, chain sliding guard	M6	10 Nm (7.4 lbf ft) Loctite®243™
----------------------------	----	---

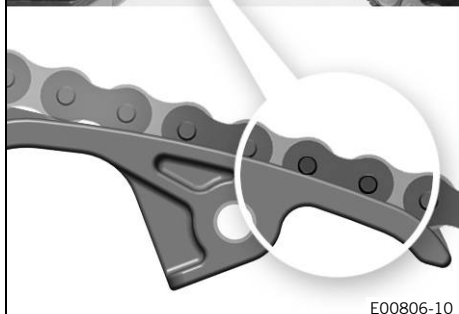

E00806-10

- Check the chain sliding piece for wear.
 - » If the lower edge of the chain pins is in line with or below the chain sliding piece:
 - Change the chain sliding piece. 🛠️
- Check that the chain sliding piece is firmly seated.
 - » If the chain sliding piece is loose:
 - Tighten the screw of the chain sliding piece.

Guideline

Screw, chain sliding piece	M8	15 Nm (11.1 lbf ft)
----------------------------	----	------------------------

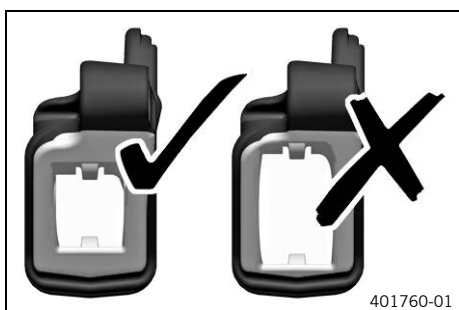

401760-01

- Check the chain guide for wear.

i Info

Wear can be seen on the front of the chain guide.

- » If the light part of the chain guide is worn:
 - Change the chain guide. 🛠️

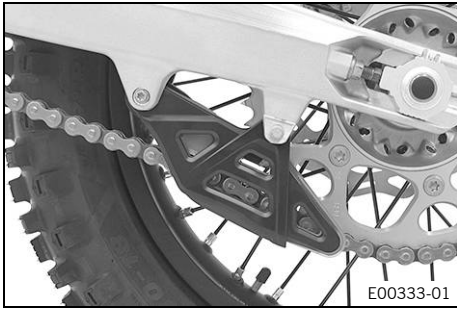

- Check that the chain guide is firmly seated.
 - » If the chain guide is loose:
 - Tighten the screws on the chain guide.

Guideline

Remaining screws, chassis	M6	10 Nm (7.4 lbf ft)
Remaining nuts, chassis	M6	10 Nm (7.4 lbf ft)

Finishing work

- Remove the motorcycle from the lift stand. (📖 p. 63)

12.40 Checking the frame 🛠️

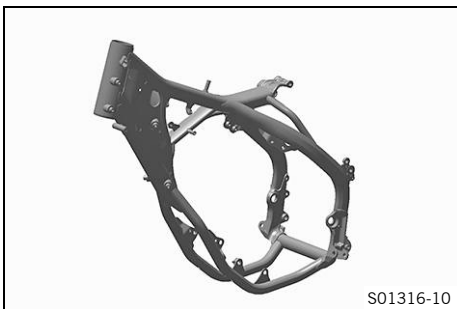

- Check the frame for damage, cracking, and deformation.
 - » If the frame shows signs of damage, cracking, or deformation:

- Change the frame. 🛠️

Guideline

Repairs on the frame are not permitted.

12.41 Checking the link fork 🛠️



- Check the link fork for damage, cracking, and deformation.
 - » If the link fork exhibits damage, cracking, or deformation:
 - Change the link fork. 🛠️

i Info

Always replace a damaged link fork. Repairing the link fork is not authorized by KTM.

12.42 Checking the throttle cable routing



Warning

Danger of accidents The throttle cable can become kinked, trapped or blocked if it is not routed correctly.

If the throttle cable is kinked, trapped or blocked, the speed can no longer be controlled.

- Make sure that the throttle cable routing and the play in throttle cable complies with the specification.

Preparatory work

- Remove the seat. (📖 p. 77)
- Remove the fuel tank. 🛠️ (📖 p. 85)



Main work

- Check the throttle cable routing.

Both throttle cables must be routed, side by side, on the back of the handlebars and above the fuel tank bracket, to the throttle valve body. Both throttle cables must be secured behind the rubber strap of the fuel tank support.

- » If the throttle cable is not routed as specified:
 - Correct the throttle cable routing.

Finishing work

- Install the fuel tank. (🔧 (📖 p. 86)
- Mount the seat. (📖 p. 77)

12.43 Checking the rubber grip

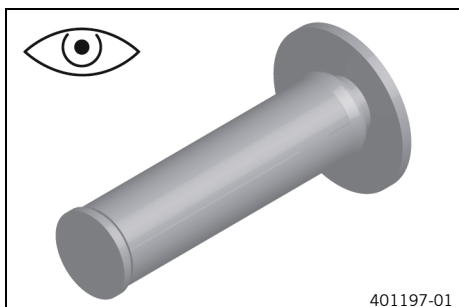

- Check the rubber grips on the handlebar for damage, wear, and looseness.

i Info
The rubber grips are vulcanized onto a sleeve on the left and onto the handle tube of the throttle grip on the right. The left sleeve is clamped onto the handlebar. The rubber grip can only be replaced with the sleeve or the throttle tube.

- » If a rubber grip is damaged, worn, or loose:
 - Change the rubber grip.

(All EU models)

- Check that screw ❶ is firmly seated.

Guideline

Screw, fixed grip	M4	5 Nm (3.7 lbf ft) Loctite®243™
-------------------	----	--

Diamond ❶ **A** must be positioned visibly as shown in the figure.

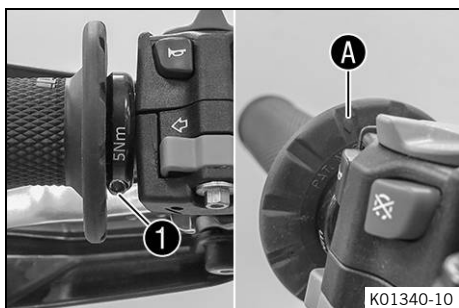

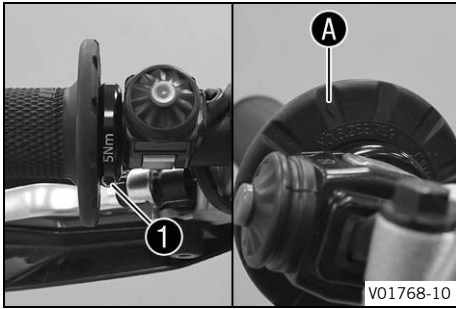

(XCF-W)

- Check that screw 1 is firmly seated.

Guideline

Screw, fixed grip	M4	5 Nm (3.7 lbf ft) Loctite®243™
-------------------	----	--

Diamond A must be positioned visibly as shown in the figure.

12.44 Adjusting the basic position of the clutch lever

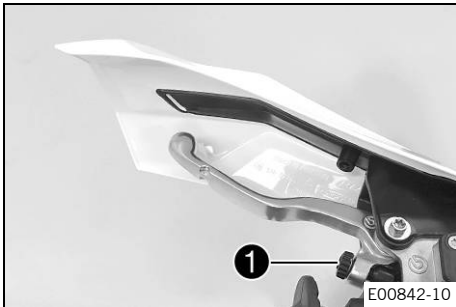

- Adjust the basic position of the clutch lever to your hand size by turning adjusting screw 1.

i Info
Turn the adjusting screw clockwise to increase the distance between the clutch lever and the handlebar. Turn the adjusting screw counterclockwise to decrease the distance between the clutch lever and the handlebar.
The range of adjustment is limited.
Turn the adjusting screw by hand only, and do not apply any force.
Do not make any adjustments while riding.

12.45 Checking/correcting the fluid level of the hydraulic clutch

! Warning
Skin irritation Brake fluid causes skin irritation.

- Keep brake fluid out of the reach of children.
- Wear suitable protective clothing and safety glasses.
- Do not allow brake fluid to come into contact with the skin, the eyes or clothing.
- Consult a doctor immediately if brake fluid has been swallowed.
- Rinse the affected area with plenty of water in the event of contact with the skin.
- Rinse eyes thoroughly with water immediately and consult a doctor if brake fluid comes into contact with the eyes.
- If brake fluid spills on to your clothing, change the clothing.

🌿 Note
Environmental hazard Hazardous substances cause environmental damage.

- Dispose of oils, grease, filters, fuel, cleaning agents, brake fluid, etc., correctly and in compliance with the applicable regulations.

i Info
The fluid level rises with increasing wear of the clutch facing discs.
Never use DOT 5 brake fluid. It is silicone-based and purple in color. Oil seals and clutch lines are not designed for DOT 5 brake fluid.
Avoid contact between brake fluid and painted parts. Brake fluid attacks paint.
Only use clean brake fluid from a sealed container.

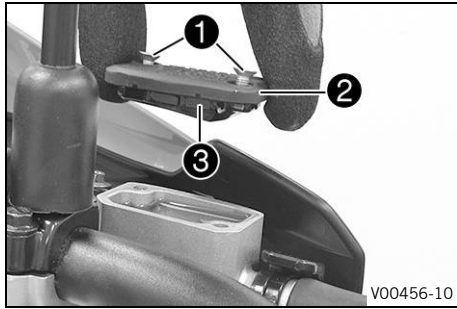

- Move the clutch fluid reservoir mounted on the handlebar to a horizontal position.
- Remove screws ①.
- Remove cover ② with membrane ③.
- Check the fluid level.

Fluid level below container rim	4 mm (0.16 in)
---------------------------------	----------------

- » If the fluid level does not meet specifications:
 - Correct the fluid level of the hydraulic clutch.

Brake fluid DOT 4 / DOT 5.1 (🗨️ p. 164)

- Position the cover with the membrane. Mount and tighten the screws.



Info

Clean up overflowed or spilled brake fluid immediately with water.

12.46 Changing the hydraulic clutch fluid 🐉



Warning

Skin irritation Brake fluid causes skin irritation.

- Keep brake fluid out of the reach of children.
- Wear suitable protective clothing and safety glasses.
- Do not allow brake fluid to come into contact with the skin, the eyes or clothing.
- Consult a doctor immediately if brake fluid has been swallowed.
- Rinse the affected area with plenty of water in the event of contact with the skin.
- Rinse eyes thoroughly with water immediately and consult a doctor if brake fluid comes into contact with the eyes.
- If brake fluid spills on to your clothing, change the clothing.



Note

Environmental hazard Hazardous substances cause environmental damage.

- Dispose of oils, grease, filters, fuel, cleaning agents, brake fluid, etc., correctly and in compliance with the applicable regulations.



Info

Never use DOT 5 brake fluid. It is silicone-based and purple in color. Oil seals and clutch lines are not designed for DOT 5 brake fluid.

Avoid contact between brake fluid and painted parts. Brake fluid attacks paint.

Only use clean brake fluid from a sealed container.

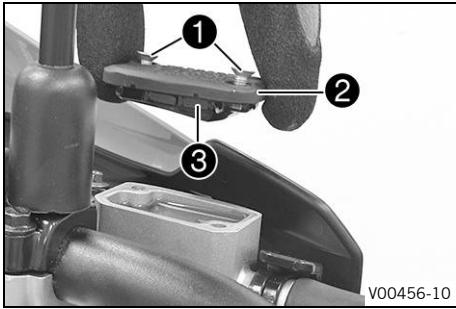

- Move the hydraulic clutch fluid reservoir mounted on the handlebar into a horizontal position.
- Remove screws ①.
- Take off cover ② with membrane ③.

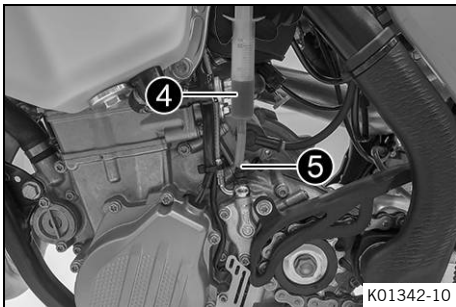

- Fill bleeding syringe ④ with the appropriate hydraulic fluid.

Syringe (50329050000)
Brake fluid DOT 4 / DOT 5.1 (📖 p. 164)

- On the clutch slave cylinder, remove the protection cap, remove bleeder screw ⑤ and mount bleeding syringe ④.

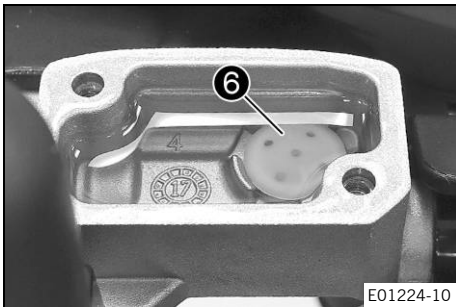

- Now inject fluid into the system until it escapes from the opening ⑥ of the master cylinder without bubbles.
- Occasionally extract the fluid from the master cylinder reservoir to prevent overflowing.
- Remove the bleeding syringe. Mount and tighten the bleeder screw. Mount the protection cap.
- Correct the fluid level of the hydraulic clutch.

Guideline

Fluid level below container rim	4 mm (0.16 in)
---------------------------------	----------------

- Position the cover with the membrane. Mount and tighten the screws.

i Info
Immediately clean up any brake fluid that has overflowed or spilled with water.

12.47 Removing the engine guard (EXC-F SIX DAYS, XCF-W)

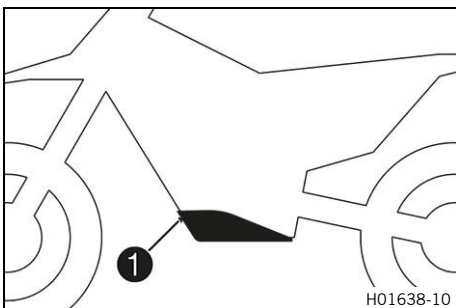

- Remove screws ① and engine guard.

12.48 Installing the engine guard (EXC-F SIX DAYS, XCF-W)

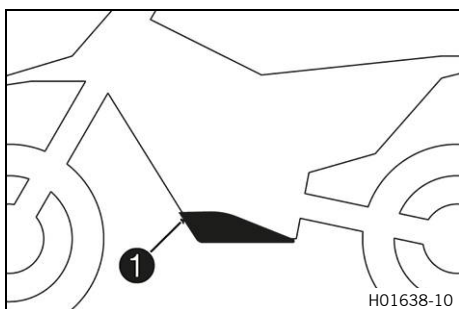

- Attach the engine guard on the frame at the rear and swing up at the front.
- Mount and tighten screws ①.

Guideline

Remaining screws, chassis	M6	10 Nm (7.4 lbf ft)
---------------------------	----	--------------------

13.1 Adjusting the basic position of the hand brake lever

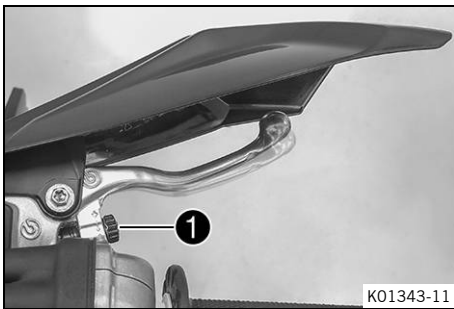

- Check the free travel of the hand brake lever.
- Adjust basic position of the hand brake lever to your hand size by turning adjusting screw ①.



Info

Turn the adjusting screw clockwise to increase the distance between the hand brake lever and the handlebar.
Turn the adjusting screw counterclockwise to decrease the distance between the hand brake lever and the handlebar.

The range of adjustment is limited.

Turn the adjusting screw by hand only, and do not apply any force.

Do not make any adjustments while riding.



13.2 Checking the brake discs



Warning

Danger of accidents Worn-out brake discs reduce the braking effect.

- Make sure that worn-out brake discs are replaced immediately. (Your authorized KTM workshop will be glad to help.)

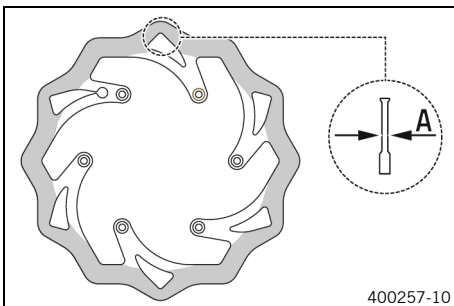

- Check the front and rear brake disc thickness at multiple points for the dimension ①.



Info

Wear reduces the thickness of the brake disc around the contact surface of the brake linings.

Brake discs - wear limit (EXC-F EU, XCF-W)	
front	2.5 mm (0.098 in)
rear	3.5 mm (0.138 in)
Brake discs - wear limit (EXC-F SIX DAYS EU)	
front	2.5 mm (0.098 in)
rear	3.7 mm (0.146 in)

- » If the brake disc thickness is less than the specified value:
 - Change the front brake disc. 🛠️
 - Change the rear brake disc. 🛠️
- Check the front and rear brake discs for damage, cracking, and deformation.
 - » If the brake disc exhibits damage, cracking, or deformation:
 - Change the front brake disc. 🛠️
 - Change the rear brake disc. 🛠️



13.3 Checking the front brake fluid level



Warning

Danger of accidents An insufficient brake fluid level will cause the brake system to fail.

If the brake fluid level drops below the specified marking or the specified value, the brake system is leaking or the brake linings are worn down.

- Check the brake system and do not continue riding until the problem is eliminated. (Your authorized KTM workshop will be glad to help.)



Warning

Danger of accidents Old brake fluid reduces the braking effect.

- Make sure that brake fluid for the front and rear brake is changed in accordance with the service schedule. (Your authorized KTM workshop will be glad to help.)

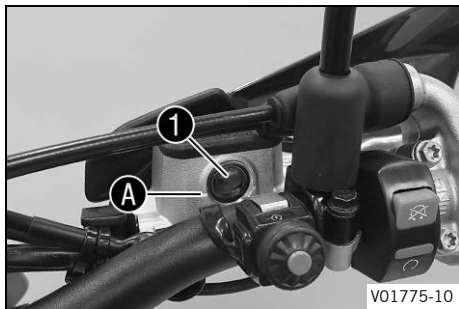

(All EU models)

- Move the brake fluid reservoir mounted on the handlebar to a horizontal position.
- Check the brake fluid level in level viewer **1**.
 - » If the brake fluid level has dropped below the marking **A**:
 - Add the front brake fluid. 🛠️ (📖 p. 100)

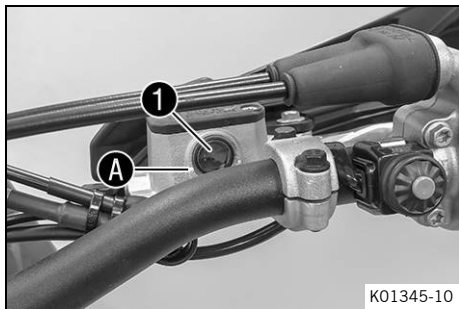

(XCF-W)

- Move the brake fluid reservoir mounted on the handlebar to a horizontal position.
- Check the brake fluid level in level viewer **1**.
 - » If the brake fluid level has dropped below the marking **A**:
 - Add the front brake fluid. 🛠️ (📖 p. 100)

13.4 Adding the front brake fluid 🛠️



Warning

Danger of accidents An insufficient brake fluid level will cause the brake system to fail.

If the brake fluid level drops below the specified marking or the specified value, the brake system is leaking or the brake linings are worn down.

- Check the brake system and do not continue riding until the problem is eliminated. (Your authorized KTM workshop will be glad to help.)



Warning

Skin irritation Brake fluid causes skin irritation.

- Keep brake fluid out of the reach of children.
- Wear suitable protective clothing and safety glasses.
- Do not allow brake fluid to come into contact with the skin, the eyes or clothing.
- Consult a doctor immediately if brake fluid has been swallowed.
- Rinse the affected area with plenty of water in the event of contact with the skin.
- Rinse eyes thoroughly with water immediately and consult a doctor if brake fluid comes into contact with the eyes.
- If brake fluid spills on to your clothing, change the clothing.



Warning

Danger of accidents Old brake fluid reduces the braking effect.

- Make sure that brake fluid for the front and rear brake is changed in accordance with the service schedule. (Your authorized KTM workshop will be glad to help.)



Note

Environmental hazard Hazardous substances cause environmental damage.

- Dispose of oils, grease, filters, fuel, cleaning agents, brake fluid, etc., correctly and in compliance with the applicable regulations.



Info

Never use DOT 5 brake fluid. It is silicone-based and purple in color. Oil seals and brake lines are not designed for DOT 5 brake fluid.

Avoid contact between brake fluid and painted parts. Brake fluid attacks paint.

Only use clean brake fluid from a sealed container.

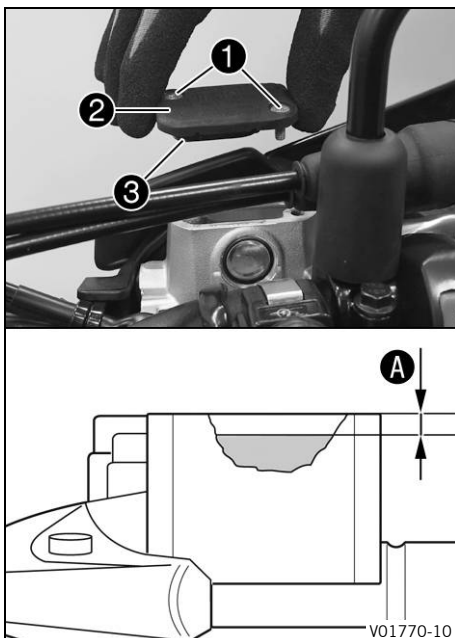

Preparatory work

- Check the front brake linings. (🔧 p. 102)

Main work

(All EU models)

- Move the brake fluid reservoir mounted on the handlebar to a horizontal position.
- Remove screws ①.
- Take off cover ② with membrane ③.
- Add brake fluid to level A.

Guideline

Level A (brake fluid level below reservoir rim)	5 mm (0.2 in)
---	---------------

Brake fluid DOT 4 / DOT 5.1 (🔧 p. 164)
--

- Position the cover with the membrane. Mount and tighten the screws.



Info

Immediately clean up any brake fluid that has overflowed or spilled with water.

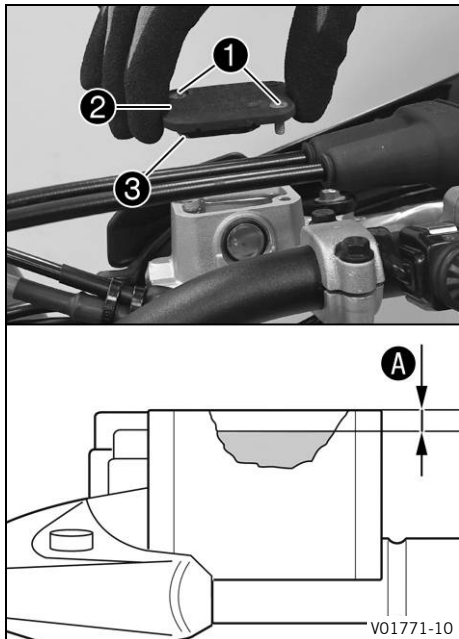

(XCF-W)

- Move the brake fluid reservoir mounted on the handlebar to a horizontal position.
- Remove screws ①.
- Take off cover ② with membrane ③.
- Add brake fluid to level A.

Guideline

Level A (brake fluid level below reservoir rim)	5 mm (0.2 in)
---	---------------

Brake fluid DOT 4 / DOT 5.1 (📖 p. 164)
--

- Position the cover with the membrane. Mount and tighten the screws.

i Info Immediately clean up any brake fluid that has overflowed or spilled with water.

13.5 Checking the front brake linings



Warning

Danger of accidents Worn-out brake linings reduce the braking effect.

- Ensure that worn-out brake linings are replaced immediately. (Your authorized KTM workshop will be glad to help.)

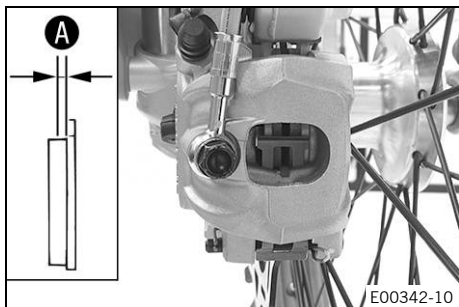

- Check the brake linings for minimum thickness A.

Minimum thickness A	≥ 1 mm (≥ 0.04 in)
---------------------	--------------------

- » If the minimum thickness is less than specified:
 - Change the brake linings of the front brake. 🛠 (📖 p. 102)
- Check the brake linings for damage and cracking.
 - » If damage or cracking is visible:
 - Change the brake linings of the front brake. 🛠 (📖 p. 102)

13.6 Changing the brake linings of the front brake 🛠



Warning

Danger of accidents Incorrect servicing will cause the brake system to fail.

- Ensure that service work and repairs are performed professionally. (Your authorized KTM workshop will be glad to help.)

**Warning****Skin irritation** Brake fluid causes skin irritation.

- Keep brake fluid out of the reach of children.
- Wear suitable protective clothing and safety glasses.
- Do not allow brake fluid to come into contact with the skin, the eyes or clothing.
- Consult a doctor immediately if brake fluid has been swallowed.
- Rinse the affected area with plenty of water in the event of contact with the skin.
- Rinse eyes thoroughly with water immediately and consult a doctor if brake fluid comes into contact with the eyes.
- If brake fluid spills on to your clothing, change the clothing.

**Warning****Danger of accidents** Old brake fluid reduces the braking effect.

- Make sure that brake fluid for the front and rear brake is changed in accordance with the service schedule. (Your authorized KTM workshop will be glad to help.)

**Warning****Danger of accidents** Oil or grease on the brake discs reduces the braking effect.

- Always keep the brake discs free of oil and grease.
- Clean the brake discs with brake cleaner when necessary.

**Warning****Danger of accidents** Brake linings which have not been approved alter the braking efficiency.

Not all brake linings are tested and approved for KTM motorcycles. The structure and friction coefficient of the brake linings, and thus their brake power, may vary greatly from that of original brake linings.

If brake linings are used that differ from the original equipment, compliance with the original homologation is not guaranteed. In this case, the vehicle no longer corresponds to its condition at delivery and the manufacturer warranty shall be void.

- Only use brake linings approved and recommended by KTM.

**Note****Environmental hazard** Hazardous substances cause environmental damage.

- Dispose of oils, grease, filters, fuel, cleaning agents, brake fluid, etc., correctly and in compliance with the applicable regulations.

**Info**

Never use DOT 5 brake fluid. It is silicone-based and purple in color. Oil seals and brake lines are not designed for DOT 5 brake fluid.

Avoid contact between brake fluid and painted parts. Brake fluid corrodes paint.

Only use clean brake fluid from a sealed container.

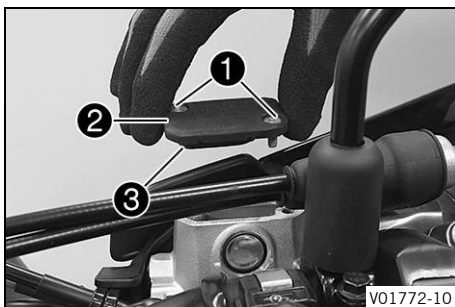
**(All EU models)**

- Move the brake fluid reservoir mounted on the handlebar to a horizontal position.
- Remove screws ①.
- Take off cover ② with membrane ③.
- Manually press the brake caliper toward the brake disc to push back the brake pistons. Ensure that brake fluid does not flow out of the brake fluid reservoir; extract some if necessary.

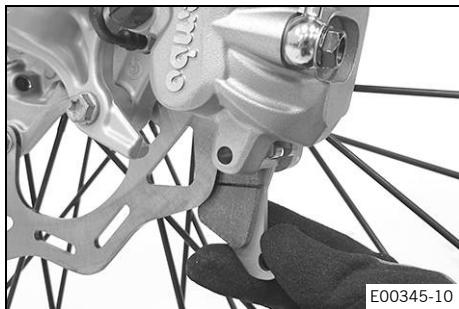
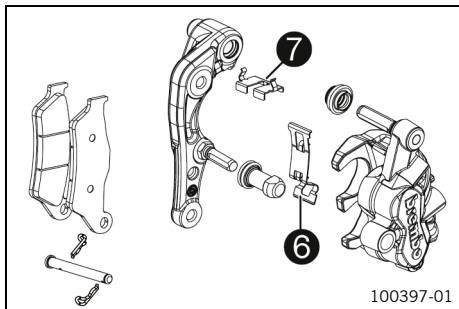
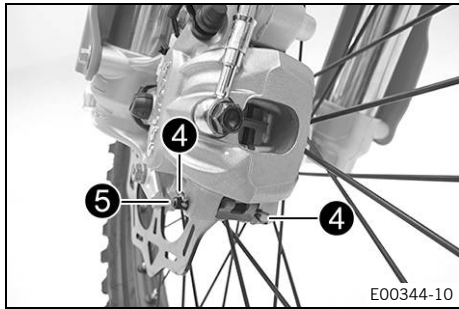

i Info
Make sure that you do not press the brake caliper against the spokes when pushing back the brake pistons.

- Remove cotter pin 4, pull out pin 5, and remove the brake linings.
- Clean the brake caliper and the brake caliper bracket.

- Check that spring plate 6 in the brake caliper and brake pad sliding plate 7 in the brake caliper bracket are seated correctly.

- Insert the new brake linings, insert the pin, and mount the cotter pins.

i Info
Always change the brake linings in pairs.

- Operate the hand brake lever repeatedly until the brake linings are in contact with the brake disc and there is a pressure point.

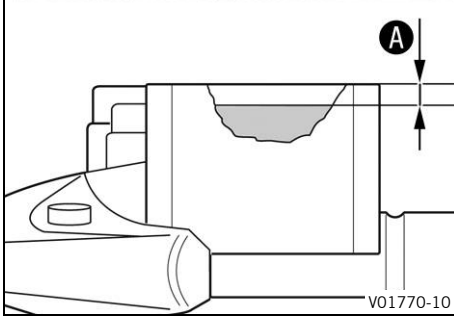
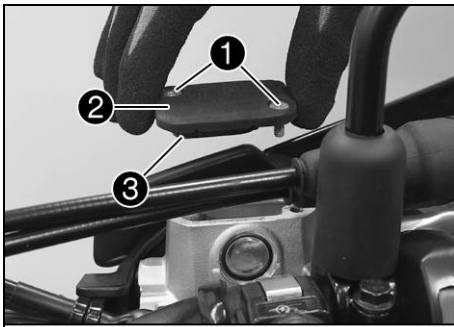

- Correct the brake fluid level to level **A**.

Guideline

Level A (brake fluid level below reservoir rim)	5 mm (0.2 in)
--	---------------

Brake fluid DOT 4 / DOT 5.1 (📖 p. 164)
--

- Position cover **2** with membrane **3**. Mount and tighten screws **1**.

i Info
Use water to immediately clean up any brake fluid that has overflowed or spilled.

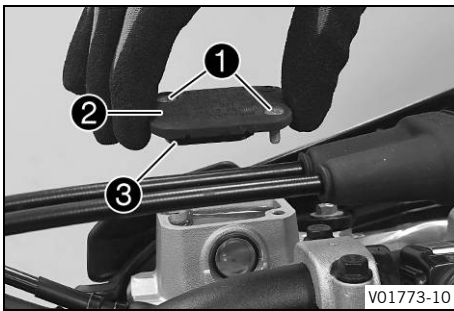

(XCF-W)

- Move the brake fluid reservoir mounted on the handlebar to a horizontal position.
- Remove screws **1**.
- Take off cover **2** with membrane **3**.
- Manually press the brake caliper toward the brake disc to push back the brake pistons. Ensure that brake fluid does not flow out of the brake fluid reservoir; extract some if necessary.

i Info
Make sure that you do not press the brake caliper against the spokes when pushing back the brake pistons.

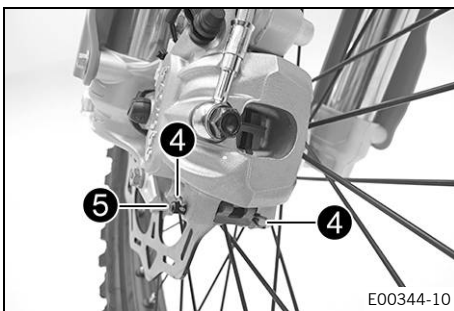

- Remove cotter pin **4**, pull out pin **5**, and remove the brake linings.
- Clean the brake caliper and the brake caliper bracket.

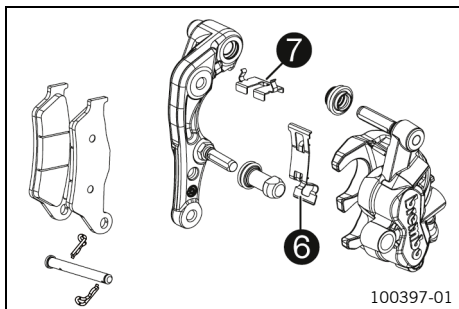

- Check that spring plate **6** in the brake caliper and brake pad sliding plate **7** in the brake caliper bracket are seated correctly.

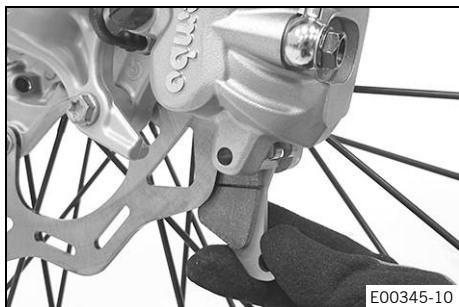

- Insert the new brake linings, insert the pin, and mount the cotter pins.

i Info
Always change the brake linings in pairs.

- Operate the hand brake lever repeatedly until the brake linings are in contact with the brake disc and there is a pressure point.

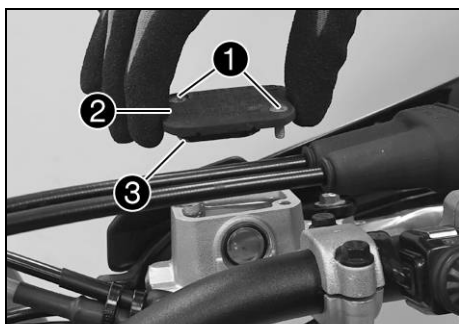

- Correct the brake fluid level to level **A**.

Guideline

Level A (brake fluid level below reservoir rim)	5 mm (0.2 in)
--	---------------

Brake fluid DOT 4 / DOT 5.1 (📖 p. 164)
--

- Position cover **2** with membrane **3**. Mount and tighten screws **1**.

i Info
Use water to immediately clean up any brake fluid that has overflowed or spilled.

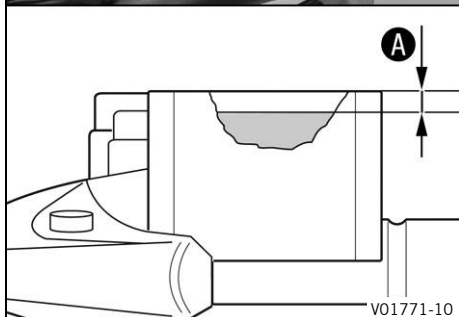

13.7 Checking the free travel of foot brake lever



Warning

Danger of accidents The brake system fails in the event of overheating.

If there is no free travel on the foot brake lever, pressure builds up in the brake system on the rear brake.

- Set the free travel on the foot brake lever in accordance with the specification.

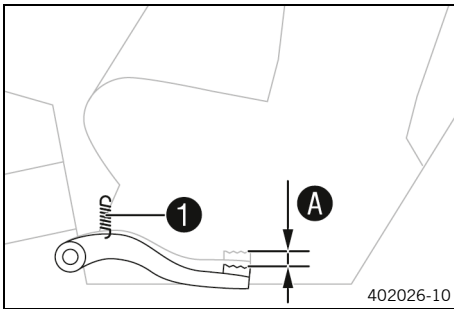

- Disconnect spring **1**.
- Move the foot brake lever back and forth between the end stop and the contact to the foot brake cylinder piston and check free travel **A**.

Guideline

Free travel at foot brake lever	3 ... 5 mm (0.12 ... 0.2 in)
---------------------------------	------------------------------

- » If the free travel does not meet specifications:
 - Adjust the basic position of the foot brake lever. ↗ (p. 107)
- Reconnect spring **1**.



13.8 Adjusting the basic position of the foot brake lever ↗



Warning

Danger of accidents The brake system fails in the event of overheating.

If there is no free travel on the foot brake lever, pressure builds up in the brake system on the rear brake.

- Set the free travel on the foot brake lever in accordance with the specification.

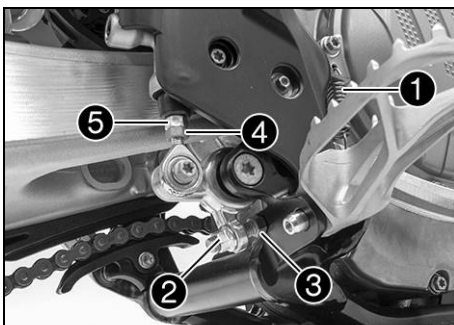

- Detach spring **1**.
- Loosen nut **4** and, with push rod **5**, turn it back until you have maximum free travel.
- To adjust the basic position of the foot brake lever to individual requirements, loosen nut **2** and turn screw **3** accordingly.



Info

The range of adjustment is limited.

- Turn push rod **5** accordingly until you have free travel **A**. If necessary, adjust the basic position of the foot brake lever.

Guideline

Free travel at foot brake lever	3 ... 5 mm (0.12 ... 0.2 in)
---------------------------------	------------------------------

- Hold screw **3** and tighten nut **2**.

Guideline

Nut, foot brake lever stop	M8	20 Nm (14.8 lbf ft)
----------------------------	----	---------------------

- Hold push rod **5** and tighten nut **4**.

Guideline

Remaining nuts, chassis	M6	10 Nm (7.4 lbf ft)
-------------------------	----	--------------------

- Attach spring **1**.

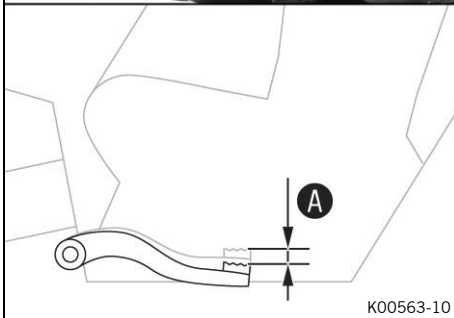

13.9 Checking the rear brake fluid level



Warning

Danger of accidents An insufficient brake fluid level will cause the brake system to fail.

If the brake fluid level drops below the specified marking or the specified value, the brake system is leaking or the brake linings are worn down.

- Check the brake system and do not continue riding until the problem is eliminated. (Your authorized KTM workshop will be glad to help.)



Warning

Danger of accidents Old brake fluid reduces the braking effect.

- Make sure that brake fluid for the front and rear brake is changed in accordance with the service schedule. (Your authorized KTM workshop will be glad to help.)

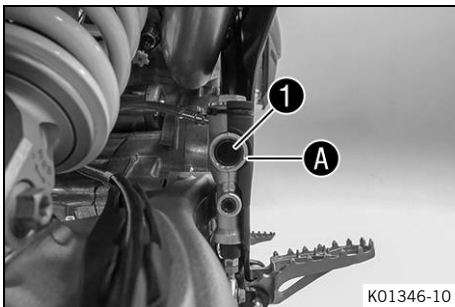

- Stand the vehicle upright.
- Check the brake fluid level in level viewer ①.
 - » If the brake fluid level has dropped below marking A:
 - Add rear brake fluid. 🛠️ (📖 p. 108)

13.10 Adding rear brake fluid 🛠️



Warning

Danger of accidents An insufficient brake fluid level will cause the brake system to fail.

If the brake fluid level drops below the specified marking or the specified value, the brake system is leaking or the brake linings are worn down.

- Check the brake system and do not continue riding until the problem is eliminated. (Your authorized KTM workshop will be glad to help.)



Warning

Skin irritation Brake fluid causes skin irritation.

- Keep brake fluid out of the reach of children.
- Wear suitable protective clothing and safety glasses.
- Do not allow brake fluid to come into contact with the skin, the eyes or clothing.
- Consult a doctor immediately if brake fluid has been swallowed.
- Rinse the affected area with plenty of water in the event of contact with the skin.
- Rinse eyes thoroughly with water immediately and consult a doctor if brake fluid comes into contact with the eyes.
- If brake fluid spills on to your clothing, change the clothing.



Warning

Danger of accidents Old brake fluid reduces the braking effect.

- Make sure that brake fluid for the front and rear brake is changed in accordance with the service schedule. (Your authorized KTM workshop will be glad to help.)



Note

Environmental hazard Hazardous substances cause environmental damage.

- Dispose of oils, grease, filters, fuel, cleaning agents, brake fluid, etc., correctly and in compliance with the applicable regulations.



Info

Never use DOT 5 brake fluid. It is silicone-based and purple in color. Oil seals and brake lines are not designed for DOT 5 brake fluid.

Avoid contact between brake fluid and painted parts. Brake fluid attacks paint.

Only use clean brake fluid from a sealed container.

Preparatory work

- Check the rear brake linings. (📖 p. 109)

Main work

- Stand the vehicle upright.
- Remove screw cap ① with membrane ② and the O-ring.
- Add brake fluid to level A.

Brake fluid DOT 4 / DOT 5.1 (📖 p. 164)

- Mount the screw cap with the membrane and the O-ring.



Info

Clean up overflowed or spilled brake fluid immediately with water.

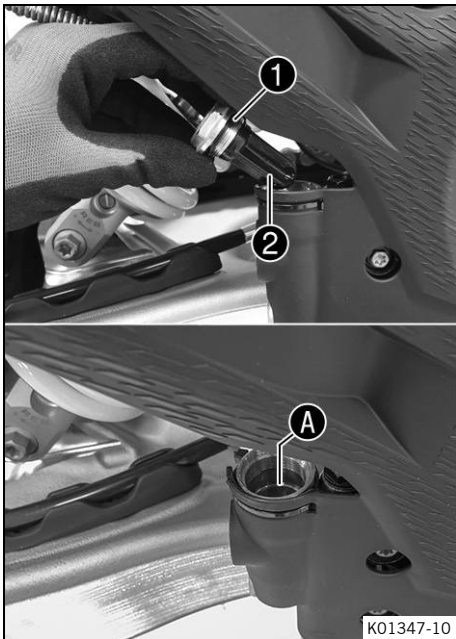

13.11 Checking the rear brake linings



Warning

Danger of accidents Worn-out brake linings reduce the braking effect.

- Ensure that worn-out brake linings are replaced immediately. (Your authorized KTM workshop will be glad to help.)

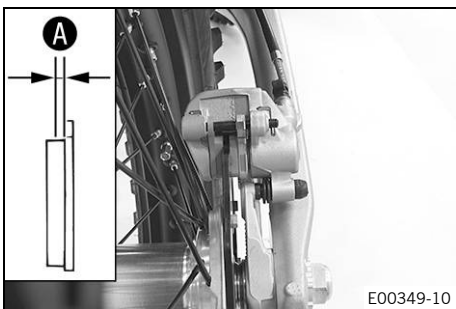

- Check the brake linings for minimum thickness A.

Minimum thickness A $\geq 1 \text{ mm } (\geq 0.04 \text{ in})$

- » If the minimum thickness is less than specified:
 - Change the rear brake linings. (📖 p. 110)
- Check the brake linings for damage and cracking.
 - » If damage or cracking is visible:
 - Change the rear brake linings. (📖 p. 110)

13.12 Changing the rear brake linings ↩



Warning

Danger of accidents Incorrect servicing will cause the brake system to fail.

- Ensure that service work and repairs are performed professionally. (Your authorized KTM workshop will be glad to help.)



Warning

Skin irritation Brake fluid causes skin irritation.

- Keep brake fluid out of the reach of children.
- Wear suitable protective clothing and safety glasses.
- Do not allow brake fluid to come into contact with the skin, the eyes or clothing.
- Consult a doctor immediately if brake fluid has been swallowed.
- Rinse the affected area with plenty of water in the event of contact with the skin.
- Rinse eyes thoroughly with water immediately and consult a doctor if brake fluid comes into contact with the eyes.
- If brake fluid spills on to your clothing, change the clothing.



Warning

Danger of accidents Old brake fluid reduces the braking effect.

- Make sure that brake fluid for the front and rear brake is changed in accordance with the service schedule. (Your authorized KTM workshop will be glad to help.)



Warning

Danger of accidents Oil or grease on the brake discs reduces the braking effect.

- Always keep the brake discs free of oil and grease.
- Clean the brake discs with brake cleaner when necessary.



Warning

Danger of accidents Brake linings which have not been approved alter the braking efficiency.

Not all brake linings are tested and approved for KTM motorcycles. The structure and friction coefficient of the brake linings, and thus their brake power, may vary greatly from that of original brake linings.

If brake linings are used that differ from the original equipment, compliance with the original homologation is not guaranteed. In this case, the vehicle no longer corresponds to its condition at delivery and the manufacturer warranty shall be void.

- Only use brake linings approved and recommended by KTM.



Note

Environmental hazard Hazardous substances cause environmental damage.

- Dispose of oils, grease, filters, fuel, cleaning agents, brake fluid, etc., correctly and in compliance with the applicable regulations.



Info

Never use DOT 5 brake fluid. It is silicone-based and purple in color. Oil seals and brake lines are not designed for DOT 5 brake fluid.

Avoid contact between brake fluid and painted parts. Brake fluid corrodes paint.

Only use clean brake fluid from a sealed container.

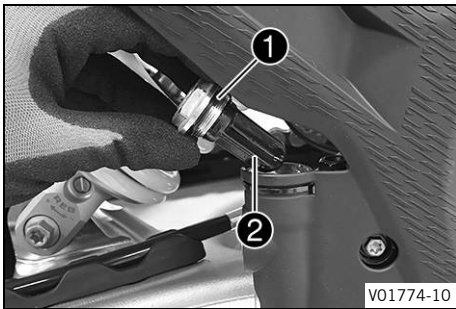

- Position the vehicle vertically.
- Remove screw cap ① with membrane ② and the O-ring.
- Press the brake piston back into the basic position and ensure that brake fluid does not flow out of the brake fluid reservoir; extract some if necessary.

i Info
Make sure that you do not press the brake caliper against the spokes when pushing back the brake piston.

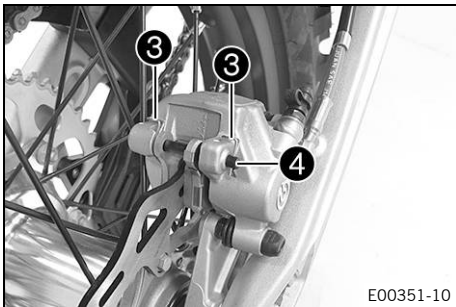

- Remove cotter pin ③, pull out pin ④, and remove the brake linings.
- Clean the brake caliper and the brake caliper bracket.

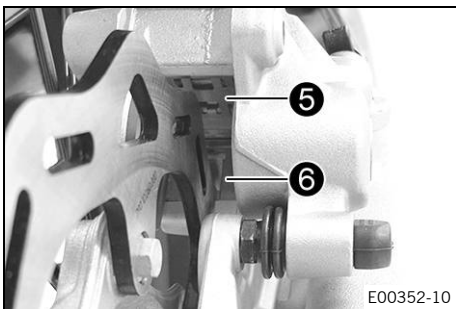

- Check that spring plate ⑤ in the brake caliper and brake pad sliding plate ⑥ in the brake caliper bracket are seated correctly.

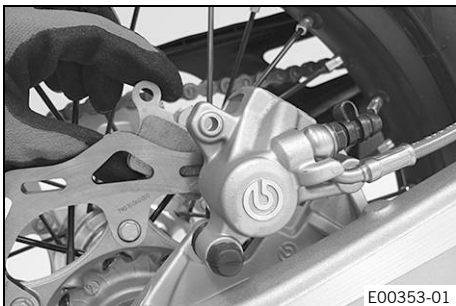

- Insert the new brake linings, insert the pin, and mount the cotter pins.

i Info
Always change the brake linings in pairs.

- Operate the foot brake lever repeatedly until the brake linings are in contact with the brake disc and there is a pressure point.

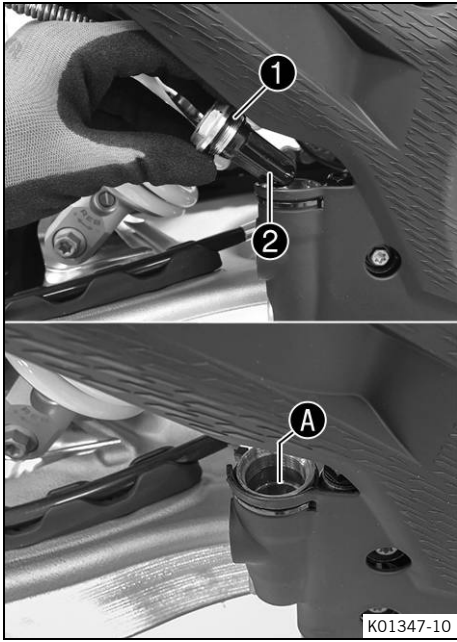

- Correct brake fluid level to marking **A**.

Brake fluid DOT 4 / DOT 5.1 (📖 p. 164)

- Mount screw cap **1** with membrane **2** and O-ring.



Info

Use water to immediately clean up any brake fluid that has overflowed or spilled.

14.1 Removing the front wheel ↩

Preparatory work

- Raise the motorcycle with the lift stand. (📖 p. 63)

Main work

- Manually press the brake caliper toward the brake disc to push back the brake pistons.



Info

Make sure that you do not press the brake caliper against the spokes when pushing back the brake pistons.

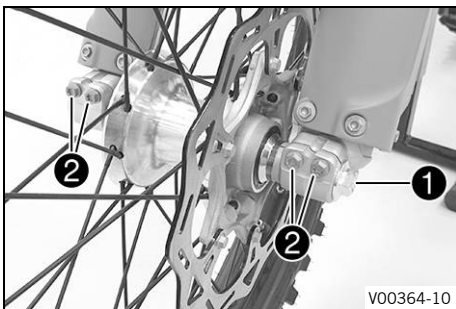

- Loosen screw ① by several rotations.
- Loosen screws ②.
- Press on screw ① to push the wheel spindle out of the axle clamp.
- Remove screw ①.

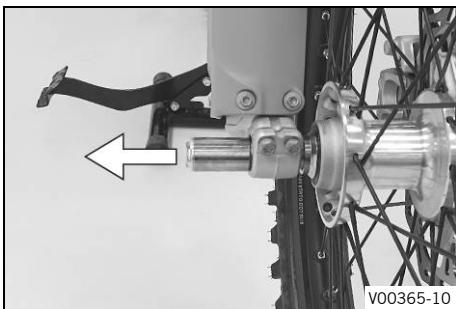

Warning

Danger of accidents Damaged brake discs reduce the braking effect.

- Always lay the wheel down in such a way that the brake disc is not damaged.

- Hold front wheel and remove wheel spindle. Take front wheel out of the fork.



Info

Do not actuate the hand brake lever when the front wheel is removed.

- Remove spacers ③.

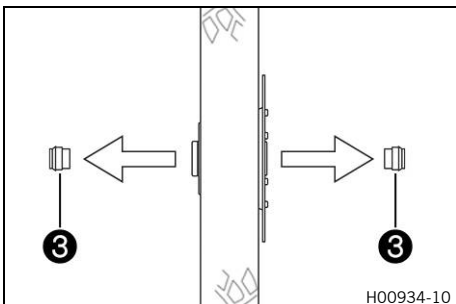

14.2 Installing the front wheel ↩



Warning

Danger of accidents Oil or grease on the brake discs reduces the braking effect.

- Always keep the brake discs free of oil and grease.
- Clean the brake discs with brake cleaner when necessary.

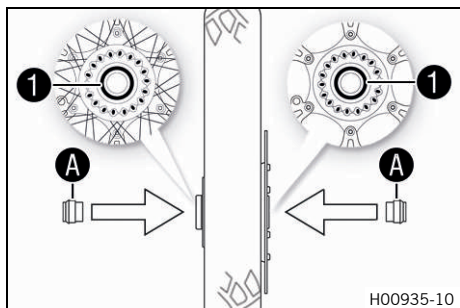

- Check the wheel bearing for damage and wear.
 - » If the wheel bearing is damaged or worn:
 - Change front wheel bearing. ↩
- Clean and grease shaft seal rings ① and contact surfaces A of the spacers.

Long-life grease (📖 p. 166)

- Insert the spacers.
- Clean and grease the wheel spindle.

Long-life grease (📖 p. 166)

- Position the front wheel and insert the wheel spindle.
 - ✓ The brake linings are correctly positioned.

- Mount and tighten screw ②.

Guideline

Screw, front wheel spindle	M20x1.5	35 Nm (25.8 lbf ft)
----------------------------	---------	---------------------

- Operate the hand brake lever several times until the brake linings are seated correctly against the brake disc.
- Remove the motorcycle from the lift stand. (📖 p. 63)
- Operate the front brake and compress the fork a few times firmly.

✓ The fork legs straighten.

- Tighten screws ③.

Guideline

Screw, fork stub	M8	15 Nm (11.1 lbf ft)
------------------	----	---------------------

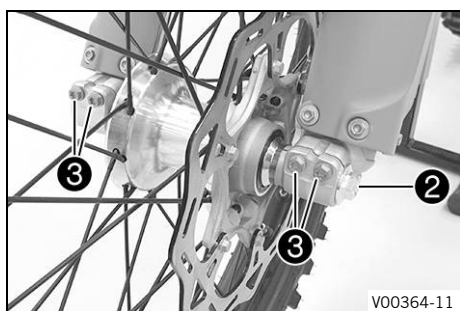

14.3 Removing the rear wheel ↩

Preparatory work

- Raise the motorcycle with the lift stand. (📖 p. 63)

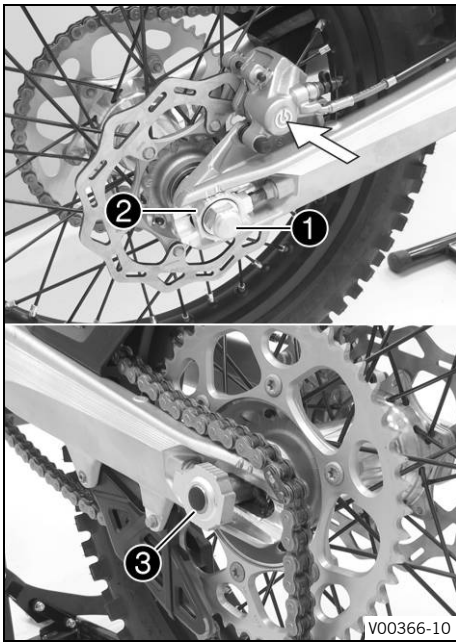

Main work

- Manually press the brake caliper toward the brake disc to push back the brake piston.

i Info
Make sure that you do not press the brake caliper against the spokes when pushing back the brake piston.

- Remove nut ①.
- Take off chain adjuster ②. Pull out wheel spindle ③ far enough to allow the rear wheel to be pushed forward.
- Push the rear wheel forward as far as possible. Remove the chain from the rear sprocket.

i Info
Cover the components to protect them against damage.

⚠ Warning
Danger of accidents Damaged brake discs reduce the braking effect.

- Always lay the wheel down in such a way that the brake disc is not damaged.

- Hold the rear wheel and remove the wheel spindle. Take the rear wheel out of the link fork.

i Info
Do not operate the foot brake lever when the rear wheel is removed.

- Remove spacers ④.

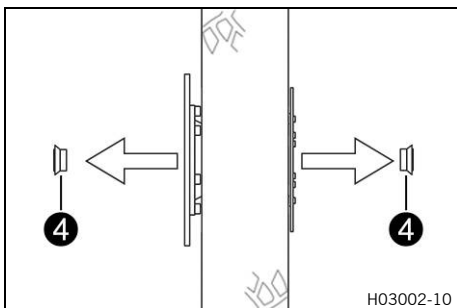

14.4 Installing the rear wheel

⚠ Warning
Danger of accidents Oil or grease on the brake discs reduces the braking effect.

- Always keep the brake discs free of oil and grease.
- Clean the brake discs with brake cleaner when necessary.

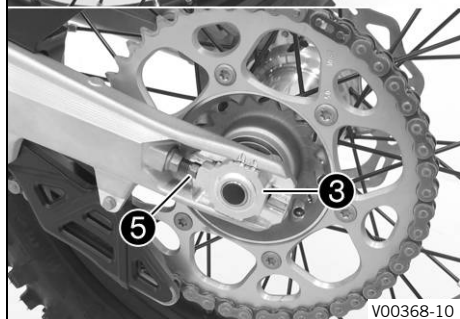
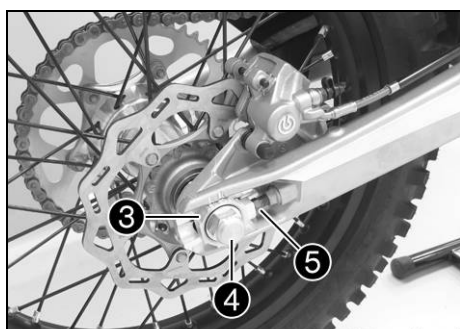
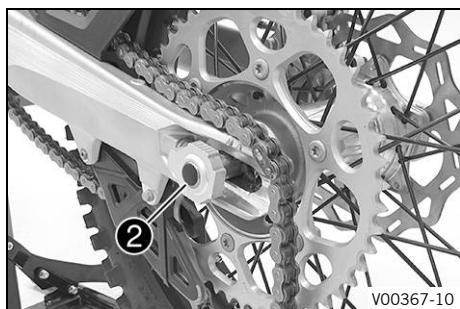
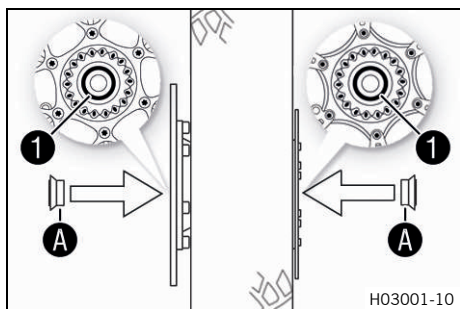

Main work

- Check the wheel bearing for damage and wear.
 - » If the wheel bearing is damaged or worn:
 - Change the rear wheel bearing. 🛠️
- Clean and grease shaft seal rings ① and contact surfaces A of the spacers.

Long-life grease (📖 p. 166)

- Insert the spacers.

- Clean and grease the wheel spindle.

Long-life grease (📖 p. 166)

- Position rear wheel and insert wheel spindle ②.
 - ✓ The brake linings are correctly positioned.
- Mount the chain.

- Position chain adjuster ③. Mount nut ④, but do not tighten it yet.
- Make sure that chain adjusters ③ are fitted correctly on adjusting screws ⑤.
- Check the chain tension. (📖 p. 89)
- Tighten nut ④.

Guideline

Nut, rear wheel spindle	M20x1.5	80 Nm (59 lbf ft)
-------------------------	---------	-------------------

i Info

The wide adjustment range of the chain adjusters (32 mm (1.26 in)) enables different secondary ratios with the same chain length.

Chain adjusters ③ can be turned by 180°.

- Operate the foot brake lever repeatedly until the brake linings are in contact with the brake disc and there is a pressure point.

Finishing work

- Remove the motorcycle from the lift stand. (📖 p. 63)

14.5 Checking the tire condition

i Info
 Only mount tires approved and/or recommended by KTM.
 Other tires could have a negative effect on handling characteristics.
 The type, condition, and pressure of the tires all have a major impact on the handling characteristic of the motorcycle.
 The tires mounted on the front and rear wheels must have a similar profile.
 Worn tires have a negative effect on handling characteristics, especially on wet surfaces.

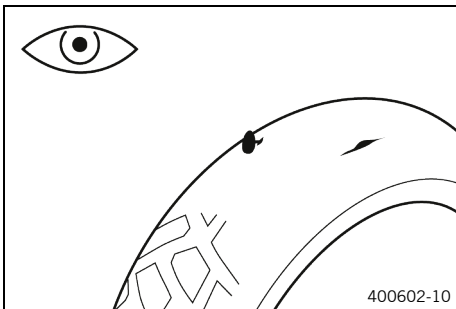

- Check the front and rear tires for cuts, run-in objects, and other damage.
 - » If the tires have cuts, run-in objects, or other damage:
 - Change the tires. 🛠️
- Check the tread depth.

i Info
 Adhere to the legally required minimum tread depth.

Minimum tread depth	≥ 2 mm (≥ 0.08 in)
---------------------	--------------------

- » If the tread depth is less than the minimum tread depth:
 - Change the tires. 🛠️
- Check the tire age.

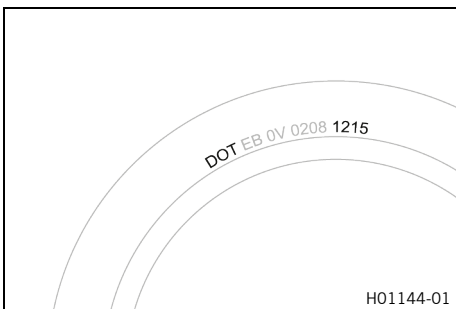

i Info
 The tire date of manufacture is usually contained in the tire label and is indicated by the last four digits of the **DOT** number. The first two digits indicate the week of manufacture and the last two digits the year of manufacture.
 KTM recommends that the tires be changed after 5 years at the latest, regardless of the actual state of wear.

- » If the tires are more than 5 years old:
 - Change the tires. 🛠️

14.6 Checking tire pressure

i Info
 Low tire pressure leads to abnormal wear and overheating of the tire.
 Correct tire pressure ensures optimal riding comfort and maximum tire service life.

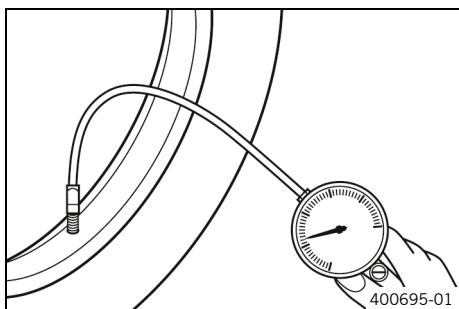

- Remove the protection cap.
- Check the tire pressure when the tires are cold.

Offroad tire pressure	
front	1.0 bar (15 psi)
rear	1.0 bar (15 psi)

Street tire pressure (XCF-W)	
front	2.0 bar (29 psi)
rear	2.0 bar (29 psi)

Street tire pressure (All EU models)	
front	1.8 bar (26 psi)
rear	1.8 bar (26 psi)

- » If the tire pressure does not meet specifications:
 - Correct the tire pressure.
- Mount the protection cap.

14.7 Checking spoke tension



Warning

Danger of accidents Incorrectly tensioned spokes impair the handling characteristic and result in secondary damage.

The spokes break due to being overloaded if they are too tightly tensioned. If the tension in the spokes is too low, then lateral and radial run-out will form in the wheel. Other spokes will become looser as a result.

- Check spoke tension regularly, and in particular on a new vehicle. (Your authorized KTM workshop will be glad to help.)

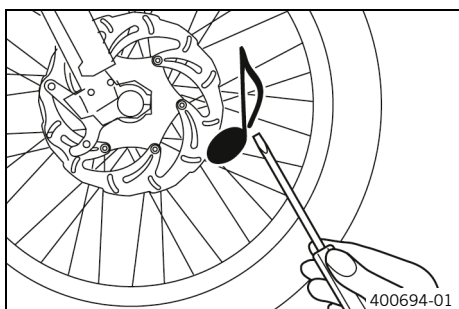

- Strike each spoke briefly using a screwdriver blade.



Info

The frequency of the sound depends on the spoke length and spoke diameter.

If you hear different tone frequencies from different spokes of equal length and diameter, this is an indication of different spoke tensions.

You should hear a high note.

- » If the spoke tension differs:
 - Correct the spoke tension. 🛠️
- Check the spoke torque.

Guideline

Spoke nipple, front wheel	M4.5	6 Nm (4.4 lbf ft)
Spoke nipple, rear wheel	M4.5	6 Nm (4.4 lbf ft)

Torque wrench kit (58429094000)

15.1 Removing the 12-V battery ↘



Warning

Risk of injury 12 V batteries contain harmful substances.

- Keep 12 V batteries out of the reach of children.
- Keep sparks and open flames away from 12 V batteries.
- Only charge 12 V batteries in well-ventilated rooms.
- Maintain a minimum clearance from inflammable materials when charging 12 V batteries.
Minimum clearance 1 m (3 ft)
- Do not charge deeply discharged 12 V batteries if the charge is already below the minimum voltage.
Minimum voltage before the start of the charge 9 V
- Dispose of 12 V batteries with less than the minimum voltage correctly.

Preparatory work

- Remove the seat. (📖 p. 77)

Main work

- Disconnect negative cable ① from the 12-V battery.
- Pull back positive terminal cover ② and disconnect the positive cable from the 12-V battery.

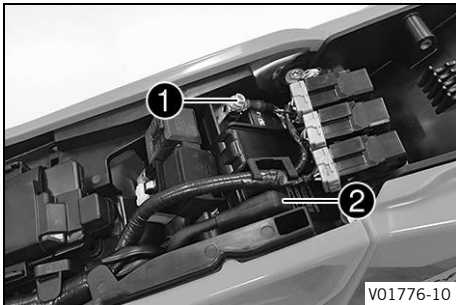

- Pull off starter relay ③ and fuse box ④ from the battery compartment and hang to the side.

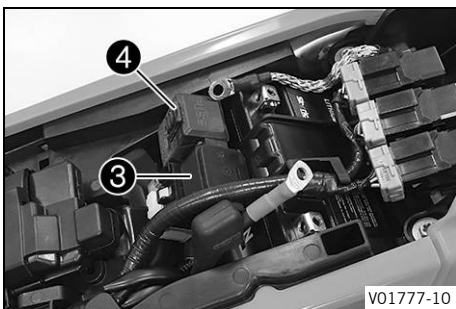

- Detach wiring harness ⑤, disconnect relays ⑥ and hang them to the side.

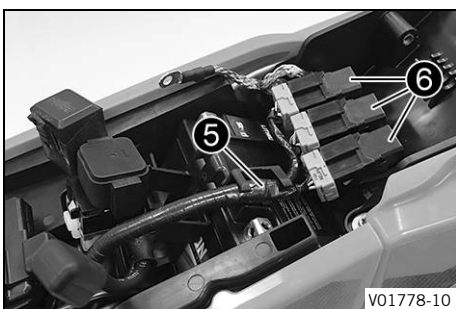

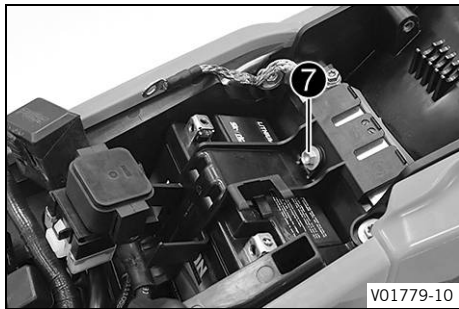

- Remove screw 7 and detach the battery compartment.
- Lift out the 12-V battery.

15.2 Installing the 12-V battery

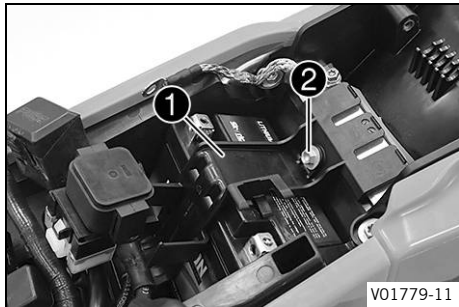

Main work

- Insert the 12 V battery into the battery compartment with the terminals facing forward and secure with holding bracket 1.

12-V battery (HJTZ5S-FP-C) (p. 160)

- Mount and tighten screw 2.

Guideline

Remaining screws, chassis	M6	10 Nm (7.4 lbf ft)
---------------------------	----	--------------------

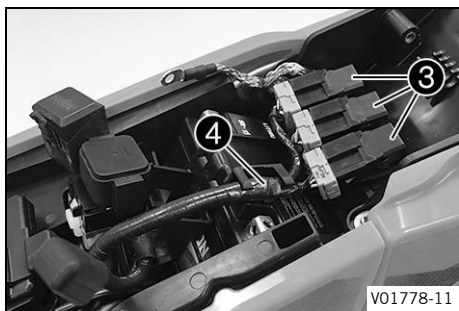

- Mount relays 3 and attach wiring harness 4.

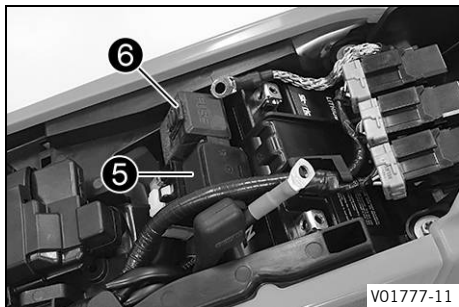

- Mount starter relay 5 and fuse box 6.

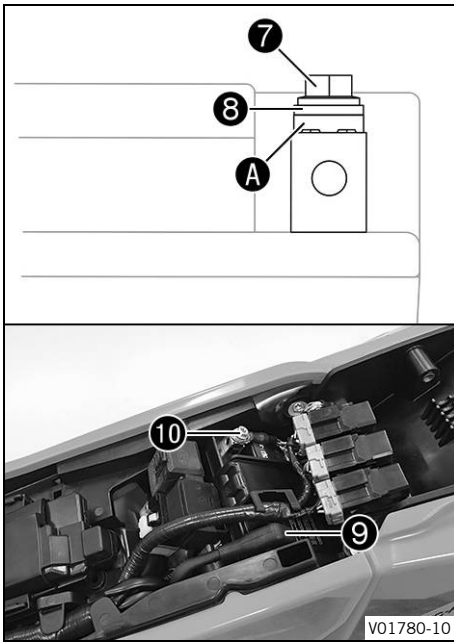

- Connect the positive cable to the 12-V battery.

Guideline

Screw, battery terminal	M5	2.5 Nm (1.84 lbf ft)
-------------------------	----	-------------------------

i Info
Contact disk **A** must be mounted under screw **7** and cable lug **8** with the claws toward the battery terminal.

- Slide positive terminal cover **9** over the positive terminal.
- Connect negative cable **10** to the 12-V battery.

Guideline

Screw, battery terminal	M5	2.5 Nm (1.84 lbf ft)
-------------------------	----	-------------------------

i Info
Contact disk **A** must be mounted under screw **7** and cable lug **8** with the claws toward the battery terminal.

Finishing work

- Mount the seat. (📖 p. 77)



15.3 Charging the 12-V battery ↩



Note

Environmental hazard 12 V batteries contain environmentally hazardous materials.

- Do not dispose of 12 V batteries as household waste.
- Dispose of 12 V batteries at a collection point for used batteries.



Note

Environmental hazard Hazardous substances cause environmental damage.

- Dispose of oils, grease, filters, fuel, cleaning agents, brake fluid, etc., correctly and in compliance with the applicable regulations.



Info

Even if there is no load on the 12-V battery, it discharges each day.

The charging level and the method of charging are very important for the service life of the 12-V battery.

Rapid recharging with a high charging current shortens the service life of the battery.

If the charging current, charging voltage, or charging time is exceeded, the 12 V battery will be destroyed.

If the 12-V battery is depleted by repeated starting, the 12-V battery must be charged immediately.

If the 12-V battery is left in a discharged state for an extended period, it will become deeply discharged and suffer a loss of capacity, destroying the battery.

The 12-V battery is maintenance-free.

Preparatory work

- Remove the seat. (📖 p. 77)
- Remove the 12-V battery. ↩ (📖 p. 119)



Main work



Warning

Risk of injury 12 V batteries contain harmful substances.

- Keep 12 V batteries out of the reach of children.
- Keep sparks and open flames away from 12 V batteries.
- Only charge 12 V batteries in well-ventilated rooms.
- Maintain a minimum clearance from inflammable materials when charging 12 V batteries.
Minimum clearance 1 m (3 ft)
- Do not charge deeply discharged 12 V batteries if the charge is already below the minimum voltage.
Minimum voltage before the start of the charge 9 V
- Dispose of 12 V batteries with less than the minimum voltage correctly.

- Check the battery voltage.
 - » Battery voltage: < 9 V
 - Do not charge the 12 V battery.
 - Replace the 12 V battery and dispose of the old 12 V battery properly.
 - » If the specifications have been met:
Battery voltage: ≥ 9 V
 - Connect a battery charger to the 12-V battery. Switch on the battery charger.

Guideline

Maximum charging voltage	14.4 V
Maximum charging current	3.0 A
Maximum charging time	24 h
Recharge the 12-V battery regularly when the motorcycle is not being used	6 months
Ideal charging and storage temperature of the lithium-ion battery	10 ... 20 °C (50 ... 68 °F)

Battery charger (79629974000)

This battery charger tests whether the 12-V battery retains its voltage. It is also impossible to overcharge the 12-V battery with this battery charger. The charging time may be longer at low temperatures.

This battery charger is only suitable for lithium iron phosphate batteries. Read the accompanying **KTM PowerParts** instructions.

i Info
Never remove cover ❶.

- Switch off the battery charger after charging and disconnect it from the 12-V battery.

Finishing work

- Install the 12-V battery. 🛠️ (📖 p. 120)
- Mount the seat. (📖 p. 77)



15.4 Changing main fuse

⚠ Warning
Fire hazard Incorrect fuses overload the electrical system.

- Only use fuses with the required ampere value.
- Do not bypass or repair fuses.

i Info
The main fuse protects all electrical power consumers of the vehicle.

Preparatory work

- Remove the seat. (📖 p. 77)

Main work

- Pull starter relay ❶ from the holder.

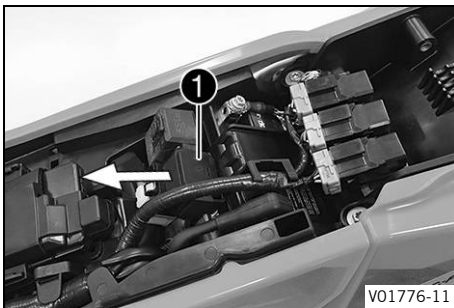

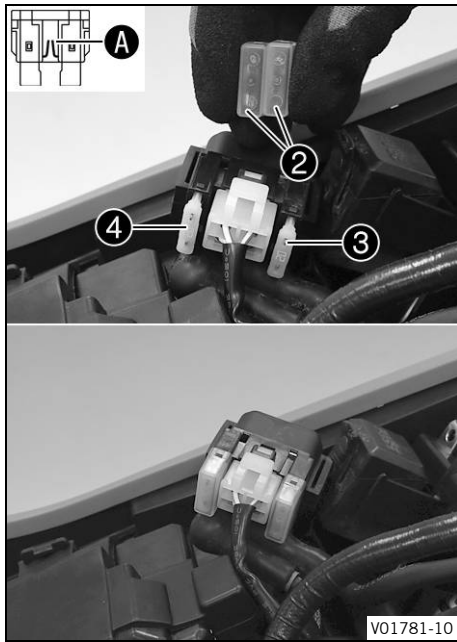

- Take off protection caps ②.
- Remove faulty main fuse ③.

i Info

A faulty fuse has a burned-out fuse wire **A**.
A spare fuse ④ is located in the starter relay.

- Insert a new main fuse.

Fuse (58011109120) (📖 p. 160)

- Check that the electrical system is functioning properly.

i Tip

Insert a spare fuse so that it is available if needed.

- Mount the starter relay onto the holder and route the cable.
- Mount the protection caps.

Finishing work

- Mount the seat. (📖 p. 77)

15.5 Changing the fuses of individual electrical power consumers

i Info

The fuse box containing the fuses of individual electrical power consumers is located under the seat.

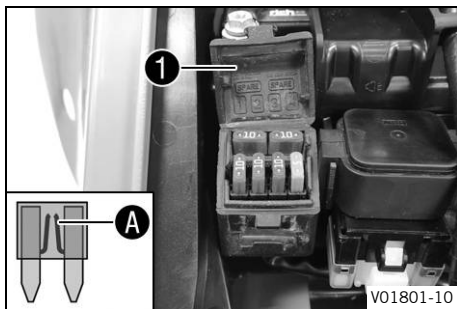

Preparatory work

- Remove the seat. (📖 p. 77)

Main work

- Open fuse box cover ①.
- Remove the faulty fuse.

**Guideline
(All EU models)**

Fuse 1 - 10 A - EFI control unit, lambda sensor, combination instrument, combination switch (optional), electronic fuel injection, diagnostics connector, fuel vapor retention system, fuse 4

Fuse 2 - 10 A - high beam, low beam, position light, tail light, license plate lamp

Fuse 3 - 10 A - radiator fan, horn, brake light, turn signal

Fuse 4 - 5 A - fuel pump

Fuses res - 10 A - spare fuse

i Info

A faulty fuse has a burned-out fuse wire **A**.

**Warning**

Fire hazard Incorrect fuses overload the electrical system.

- Only use fuses with the required ampere value.
- Do not bypass or repair fuses.

- Insert the spare fuse with the correct rating.

Fuse (75011088010) (📖 p. 160)

Fuse (75011088005) (📖 p. 160)

**Tip**

Put a spare fuse in the fuse box so that it is available if needed.

- Check the function of the electrical power consumer.
- Close the fuse box cover.

Finishing work

- Mount the seat. (📖 p. 77)

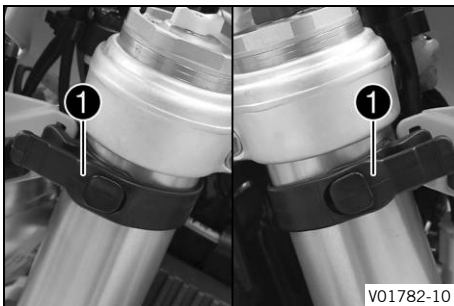
**15.6 Removing the headlight mask with the headlight**

- Detach the brake line and wiring harness from the headlight mask.
- Loosen rubber straps ①. Slide the headlight mask up and swing it forward.

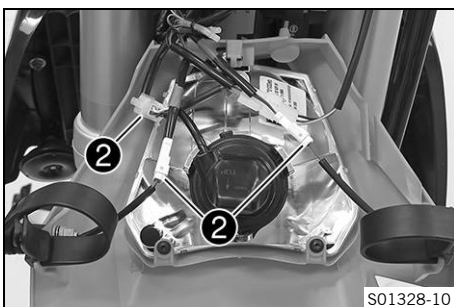
**(All EU models)**

- Detach plug-in connectors ② and take off the headlight mask with the headlight.

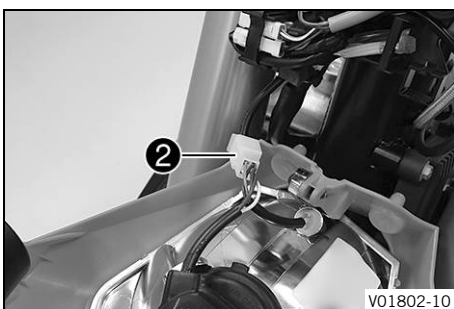
**(XCF-W)**

- Disconnect plug-in connector ② and take off the headlight mask together with the headlight.



15.7 Installing the headlight mask with the headlight

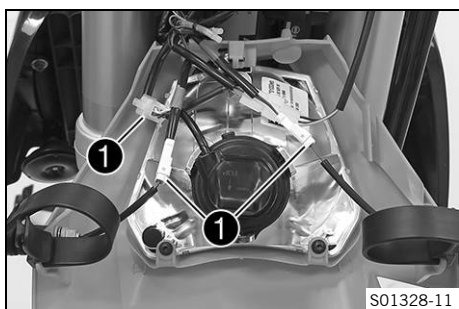

Main work (All EU models)

- Join plug-in connectors ①.



(XCF-W)

- Join plug-in connector ①.

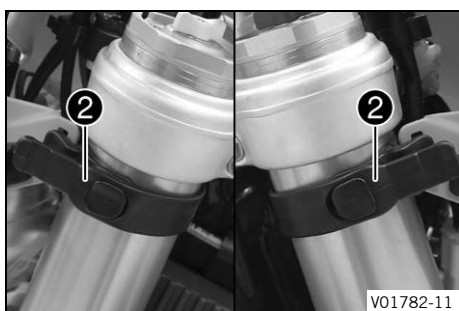

- Position the headlight mask and secure it with rubber straps ②.
- ✓ The holding lugs engage in the fender.
- Position the brake line and wiring harness in the brake line guide.

Finishing work

- Check the headlight setting. (📖 p. 127)

15.8 Changing the headlight bulb

Note

Damage to reflector Grease on the reflector reduces the light intensity.

Grease on the bulb will evaporate due to the heat and be deposited on the reflector.

- Clean and degrease the bulbs before mounting.
- Do not touch the bulbs with your bare hands.

Preparatory work

- Remove the headlight mask with the headlight. (📖 p. 125)

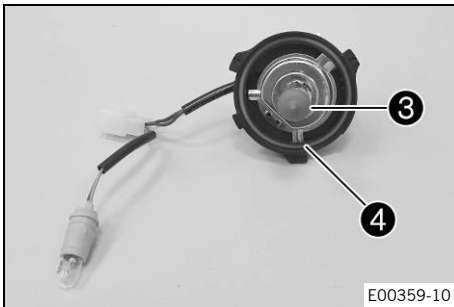
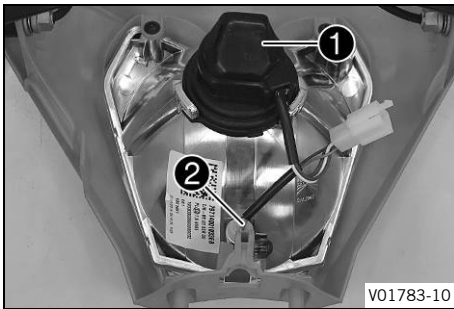

Main work

- Turn protection cap ① together with the underlying bulb socket counterclockwise all the way and remove it.
- Pull bulb socket ② of the position light out of the reflector.

- Pull out headlight bulb ③.
- Insert the new headlight bulb.

Headlight (HS1 / socket PX43t) (📖 p. 160)

- Insert the protection cap with the bulb socket into the reflector and turn it clockwise all the way.



Info

Ensure that O-ring ④ is seated properly.

- Insert the bulb socket of the position light into the reflector.

Finishing work

- Install the headlight mask with the headlight. (📖 p. 126)
- Check the headlight setting. (📖 p. 127)



15.9 Checking the headlight setting

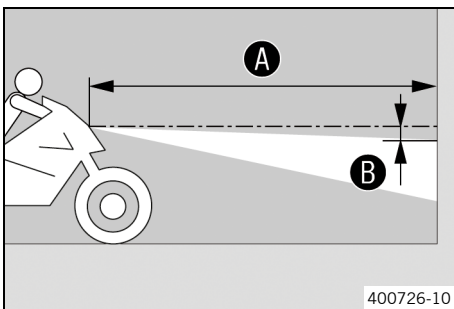

- Position the vehicle upright on a horizontal surface in front of a light wall and make a marking at the height of the center of the low beam headlight.
- Make another mark at a distance ⑤ under the first marking.

Guideline

Distance ⑤	5 cm (2 in)
------------	-------------

- Position the vehicle vertically at a distance ⑥ away from the wall.

Guideline

Distance ⑥	5 m (16 ft)
------------	-------------

- The rider now sits down on the motorcycle.
- Switch on the low beam.
- Check the headlight setting.

The boundary between light and dark must be exactly on the lower mark for a motorcycle with rider.
--

- » If the boundary between light and dark does not meet specifications:
 - Adjust the headlight range. (📖 p. 128)



15.10 Adjusting the headlight range

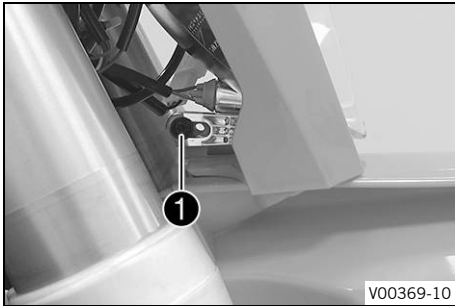

Preparatory work

- Check the headlight setting. (📖 p. 127)

Main work

- Loosen screw ①.
- Adjust the headlight range by pivoting the headlight.

Guideline

The boundary between light and dark must be exactly on the lower mark for a motorcycle with rider (instructions on how to apply the mark: Checking the headlight setting).

i Info

A change in weight on the vehicle may require a correction of the headlight range.

- Tighten screw ①.

15.11 Changing the turn signal bulb (All EU models)

Note

Damage to reflector Grease on the reflector reduces the light intensity.

Grease on the bulb will evaporate due to the heat and be deposited on the reflector.

- Clean and degrease the bulbs before mounting.
- Do not touch the bulbs with your bare hands.

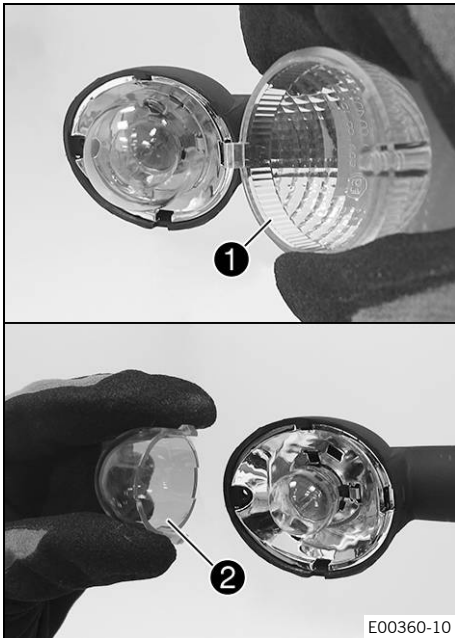

Main work

- Remove the screw on the rear of the turn signal housing.
- Carefully remove turn signal glass ①.
- Lightly squeeze together the orange cap ② in the area of the holding lugs and take it off.
- Press the turn signal bulb lightly into the socket, turn it counterclockwise by about 30°, and pull it out of the socket.

i Info

Do not touch the reflector with your fingers and keep it free from grease.

- Press the new turn signal bulb carefully into the socket and turn it clockwise until it stops.

Turn signal (R10W / socket BA15s) (📖 p. 160)

- Mount the orange cap.
- Position the turn signal glass.
- Insert the screw and first turn counterclockwise until it engages in the thread with a small jerk. Tighten the screw lightly.

Finishing work

- Check that the turn signal system is functioning properly.

15.12 Changing the combination instrument battery

Preparatory work

- Remove the headlight mask with the headlight. (📖 p. 125)

Main work

- Remove screws ❶ with the washers.
- Pull the combination instrument upward out of the holder.

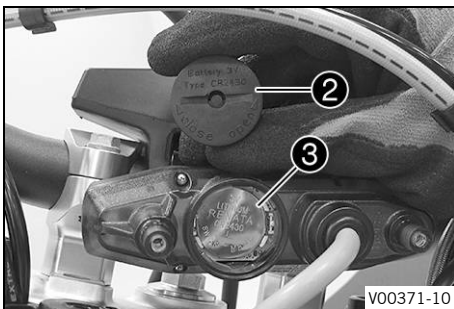
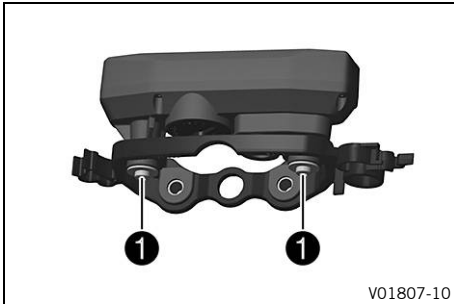

- Using a coin, turn protection cap ❷ all the way counterclockwise and take it off.
- Remove combination instrument battery ❸.
- Insert the combination instrument with the label facing upward.

Combination instrument battery (CR 2430) (📖 p. 160)

- Check the O-ring of the protection cap for correct seating.

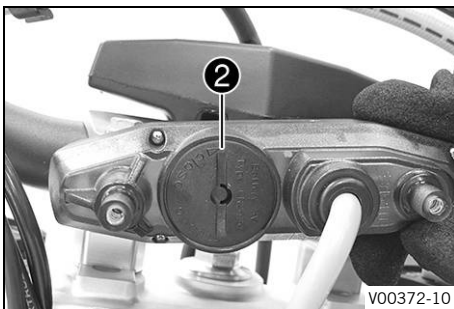

- Position protection cap ❷ and turn all the way clockwise using a coin.
- Press any button on the combination instrument.
 - ✓ The combination instrument is activated.
- Position the combination instrument in the holder.
- Mount and tighten the screws with washers.

Finishing work

- Install the headlight mask with the headlight. (📖 p. 126)
- Check the headlight setting. (📖 p. 127)
- Set kilometers or miles. (📖 p. 25)
- Set the combination instrument. (📖 p. 26)
- Set the clock. (📖 p. 26)



15.13 Diagnostics connector

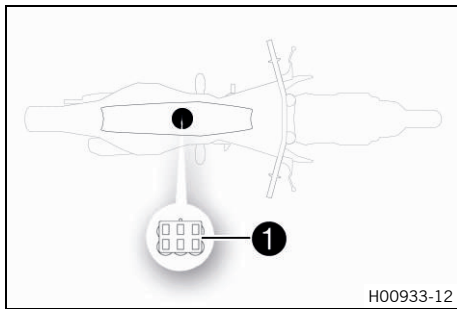

Diagnostics connector ① is located under the seat.

16.1 Cooling system

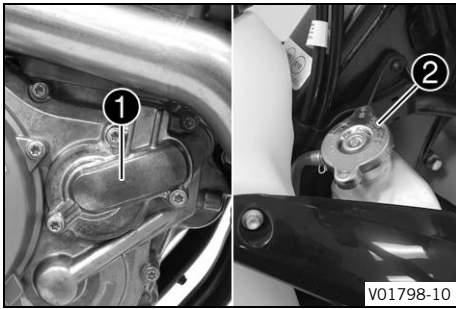

(XCF-W)

Water pump ① in the engine ensures forced circulation of the coolant.

The pressure resulting from the warming of the cooling system is regulated by a valve in radiator cap ②. This ensures that operating the vehicle at the specified coolant temperature will not result in a risk of malfunctions.

120 °C (248 °F)

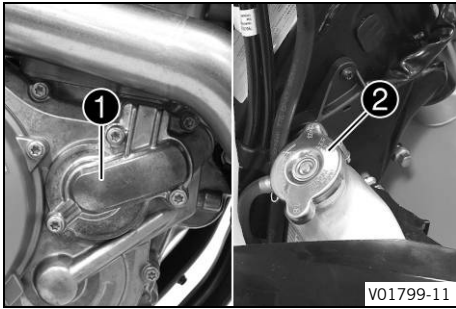

(All EU models)

Water pump ① in the engine ensures forced circulation of the coolant.

The pressure resulting from the warming of the cooling system is regulated by a valve in radiator cap ②. This ensures that operating the vehicle at the specified coolant temperature will not result in a risk of malfunctions.

120 °C (248 °F)

Cooling is effected by the air stream.

The lower the speed, the less the cooling effect. Dirty cooling fins also reduce the cooling effect.

Additional cooling is provided by the radiator fan, which is activated on a temperature-dependent basis.

16.2 Checking the antifreeze and coolant level



Warning

Danger of scalding During motorcycle operation, the coolant gets very hot and is under pressure.

- Do not open the radiator, the radiator hoses or other cooling system components if the engine or the cooling system are at operating temperature.
- Allow the cooling system and the engine to cool down before you open the radiator, the radiator hoses or other components of the cooling system.
- In the event of scalding, rinse the area affected immediately with lukewarm water.



Warning

Danger of poisoning Coolant is harmful to health.

- Keep coolant out of the reach of children.
- Do not allow coolant to come into contact with the skin, the eyes and clothing.
- Consult a doctor immediately if coolant is swallowed.
- Rinse the affected area immediately with plenty of water in the event of contact with the skin.
- Rinse eyes thoroughly with water and consult a doctor immediately if coolant gets into the eyes.
- Change clothing if coolant spills onto your clothing.

Condition

The engine is cold.

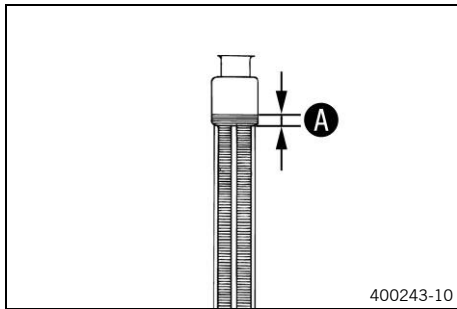

- Stand the motorcycle upright on a horizontal surface.
- Remove the radiator cap.
- Check the antifreeze in the coolant.

-25 ... -45 °C (-13 ... -49 °F)

» If the antifreeze in the coolant does not match the specified value:

- Correct the antifreeze in the coolant.

- Check the coolant level in the radiator.

Coolant level A above the radiator fins	10 mm (0.39 in)
--	-----------------

» If the coolant level does not match the specified value:

- Correct the coolant level.

Coolant (📖 p. 164)

- Mount the radiator cap.

16.3 Checking the coolant level



Warning

Danger of scalding During motorcycle operation, the coolant gets very hot and is under pressure.

- Do not open the radiator, the radiator hoses or other cooling system components if the engine or the cooling system are at operating temperature.
- Allow the cooling system and the engine to cool down before you open the radiator, the radiator hoses or other components of the cooling system.
- In the event of scalding, rinse the area affected immediately with lukewarm water.



Warning

Danger of poisoning Coolant is harmful to health.

- Keep coolant out of the reach of children.
- Do not allow coolant to come into contact with the skin, the eyes and clothing.
- Consult a doctor immediately if coolant is swallowed.
- Rinse the affected area immediately with plenty of water in the event of contact with the skin.
- Rinse eyes thoroughly with water and consult a doctor immediately if coolant gets into the eyes.
- Change clothing if coolant spills onto your clothing.

Condition

The engine is cold.

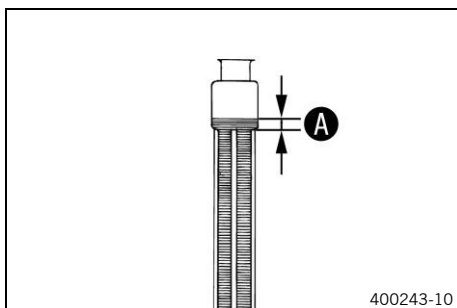

- Stand the motorcycle upright on a horizontal surface.
- Remove the radiator cap.
- Check the coolant level in the radiator.

Coolant level A above the radiator fins	10 mm (0.39 in)
--	-----------------

» If the coolant level does not match the specified value:

- Correct the coolant level.

Coolant (📖 p. 164)

- Mount the radiator cap.

16.4 Draining the coolant



Warning

Danger of scalding During motorcycle operation, the coolant gets very hot and is under pressure.

- Do not open the radiator, the radiator hoses or other cooling system components if the engine or the cooling system are at operating temperature.
- Allow the cooling system and the engine to cool down before you open the radiator, the radiator hoses or other components of the cooling system.
- In the event of scalding, rinse the area affected immediately with lukewarm water.



Warning

Danger of poisoning Coolant is harmful to health.

- Keep coolant out of the reach of children.
- Do not allow coolant to come into contact with the skin, the eyes and clothing.
- Consult a doctor immediately if coolant is swallowed.
- Rinse the affected area immediately with plenty of water in the event of contact with the skin.
- Rinse eyes thoroughly with water and consult a doctor immediately if coolant gets into the eyes.
- Change clothing if coolant spills onto your clothing.

Condition

The engine is cold.

Preparatory work

(EXC-F SIX DAYS, XCF-W)

- Remove the engine guard. (📖 p. 97)

Main work

(XCF-W)

- Position the motorcycle upright.
- Place an appropriate container under the water pump cover.
- Remove screw ❶. Take off radiator cap ❷.
- Completely drain the coolant.
- Mount and tighten screw ❶ with a new seal ring.

Guideline

Screw, water pump cover	M6	10 Nm (7.4 lbf ft)
-------------------------	----	--------------------

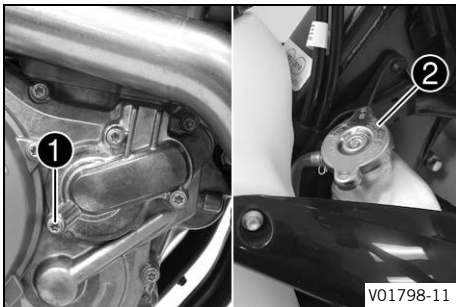

(All EU models)

- Position the motorcycle upright.
- Place an appropriate container under the water pump cover.
- Remove screw ❶. Take off radiator cap ❷.
- Completely drain the coolant.
- Mount and tighten screw ❶ with a new seal ring.

Guideline

Screw, water pump cover	M6	10 Nm (7.4 lbf ft)
-------------------------	----	--------------------

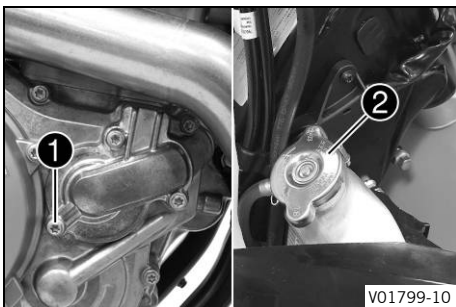

16.5 Refilling coolant



Warning

Danger of poisoning Coolant is harmful to health.

- Keep coolant out of the reach of children.
- Do not allow coolant to come into contact with the skin, the eyes and clothing.
- Consult a doctor immediately if coolant is swallowed.
- Rinse the affected area immediately with plenty of water in the event of contact with the skin.
- Rinse eyes thoroughly with water and consult a doctor immediately if coolant gets into the eyes.
- Change clothing if coolant spills onto your clothing.

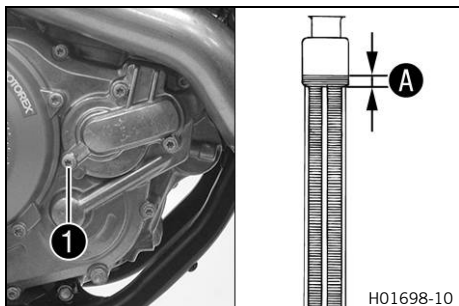

Main work

- Make sure that the screw **1** is tightened.
- Stand the vehicle upright.
- Pour coolant in up to measurement **A** above the radiator fins.

Guideline

10 mm (0.39 in)

Coolant	1.2 l (1.3 qt.)	Coolant (📖 p. 164)
---------	-----------------	--------------------

- Refit the radiator cap.

Finishing work

(EXC-F SIX DAYS, XCF-W)

- Install the engine guard. (📖 p. 98)
- Take a short test ride.
- Check the coolant level. (📖 p. 132)

16.6 Changing the coolant



Warning

Danger of scalding During motorcycle operation, the coolant gets very hot and is under pressure.

- Do not open the radiator, the radiator hoses or other cooling system components if the engine or the cooling system are at operating temperature.
- Allow the cooling system and the engine to cool down before you open the radiator, the radiator hoses or other components of the cooling system.
- In the event of scalding, rinse the area affected immediately with lukewarm water.



Warning

Danger of poisoning Coolant is harmful to health.

- Keep coolant out of the reach of children.
- Do not allow coolant to come into contact with the skin, the eyes and clothing.
- Consult a doctor immediately if coolant is swallowed.
- Rinse the affected area immediately with plenty of water in the event of contact with the skin.
- Rinse eyes thoroughly with water and consult a doctor immediately if coolant gets into the eyes.
- Change clothing if coolant spills onto your clothing.

Condition

The engine is cold.

Preparatory work

(EXC-F SIX DAYS, XCF-W)

- Remove the engine guard. (📖 p. 97)

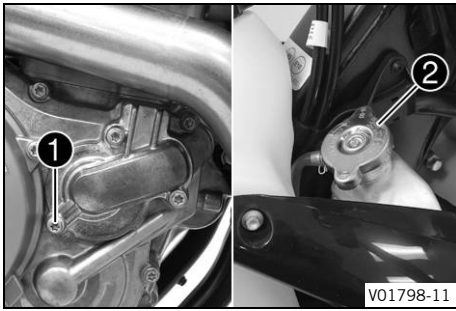

Main work

(XCF-W)

- Position the motorcycle upright.
- Place an appropriate container under the water pump cover.
- Remove screw ①. Take off radiator cap ②.
- Completely drain the coolant.

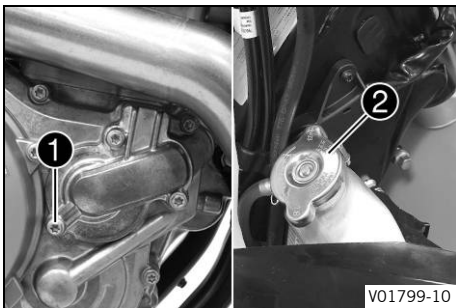

(All EU models)

- Position the motorcycle upright.
- Place an appropriate container under the water pump cover.
- Remove screw ①. Take off radiator cap ②.
- Completely drain the coolant.

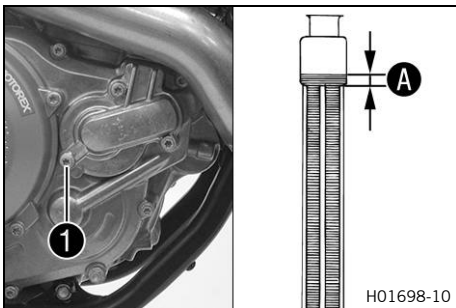

- Mount and tighten screw ① with a new seal ring.

Guideline

Screw, water pump cover	M6	10 Nm (7.4 lbf ft)
-------------------------	----	--------------------

- Pour coolant in up to level ① above the radiator fins.

Guideline

Distance ① above the radiator fins	10 mm (0.39 in)
------------------------------------	-----------------

Coolant	1.2 l (1.3 qt.)	Coolant (📖 p. 164)
---------	-----------------	--------------------

- Mount radiator cap ②.
- Go for a short test ride.
- Check the coolant level. (📖 p. 132)

Finishing work

(EXC-F SIX DAYS, XCF-W)

- Install the engine guard. (📖 p. 98)



17.1 Checking the play in the throttle cable

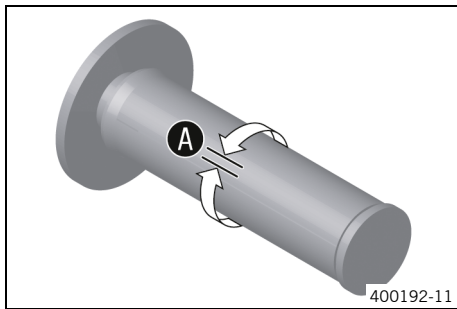

- Check the throttle grip for smooth operation.
- Move the handlebar to the straight-ahead position. Turn the throttle grip back and forth slightly and determine the play in throttle cable **A**.

Play in throttle cable	3 ... 5 mm (0.12 ... 0.2 in)
------------------------	------------------------------

- » If the throttle cable play does not meet the specified value:
 - Adjust the play in the throttle cable. 🛠️ (📖 p. 136)
- Push the cold start button in all the way.

When the throttle grip is turned forward, the cold start button returns to its original position.

- » If the cold start button does not return to its original position:
 - Adjust the play in the throttle cable. 🛠️ (📖 p. 136)



Danger

Danger of poisoning Exhaust gases are toxic and inhaling them may result in unconsciousness and death.

- Always make sure there is sufficient ventilation when running the engine.
- Use effective exhaust extraction when starting or running the engine in an enclosed space.

- Start the engine and let it run at idle speed. Move the handlebar to and fro over the entire steering range.

The idle speed must not change.

- » If the idle speed changes:
 - Adjust the play in the throttle cable. 🛠️ (📖 p. 136)

17.2 Adjusting the play in the throttle cable 🛠️



Info

If the correct routing of the throttle cables has already been secured, the fuel tank does not need to be removed.

Preparatory work

- Remove the seat. (📖 p. 77)
- Remove the fuel tank. 🛠️ (📖 p. 85)
- Check the throttle cable routing. (📖 p. 93)

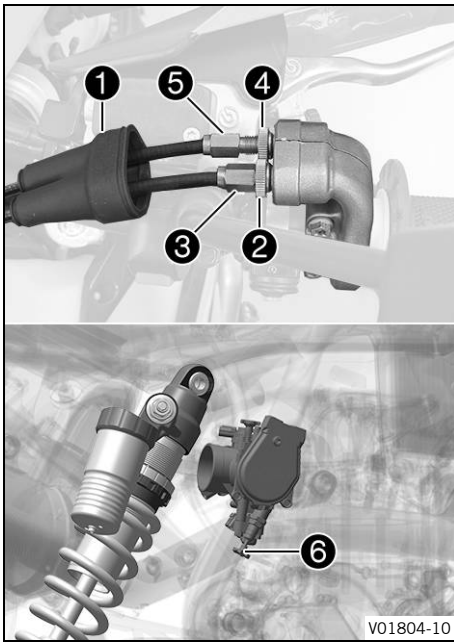

Main work

- Move the handlebar to the straight-ahead position.
- Push back sleeve ①.
- Loosen nut ②.
- Turn adjusting screw ③ in as far as possible.
- Loosen nut ④.
- Push cold start button ⑥ all the way to the stop.
- Turn adjusting screw ⑤ so that the cold start button moves to the basic position when the throttle grip is turned to the front.
- Tighten nut ④.
- Turn adjusting screw ③ so that there is play in the throttle cable at the throttle grip.

Guideline

Play in throttle cable	3 ... 5 mm (0.12 ... 0.2 in)
------------------------	------------------------------

- Tighten nut ②.
- Slide on sleeve ①.
- Check the throttle grip for smooth operation.

Finishing work

- Check the play in the throttle cable. (📖 p. 136)



17.3 Adjusting the characteristic map of the throttle response ↗

Info

On the throttle grip, the characteristic map of the throttle response is changed by changing the guide plate.

A guide plate with a different characteristic map is supplied.

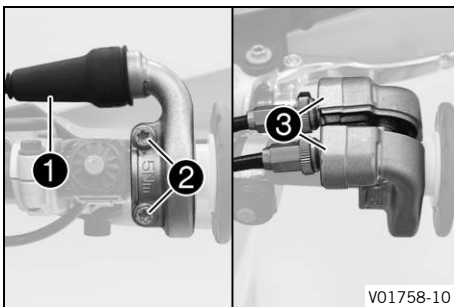

Main work

- Push back sleeve ①.
- Remove screws ② and half-shells ③.
- Detach the throttle cables and take off the grip tube.

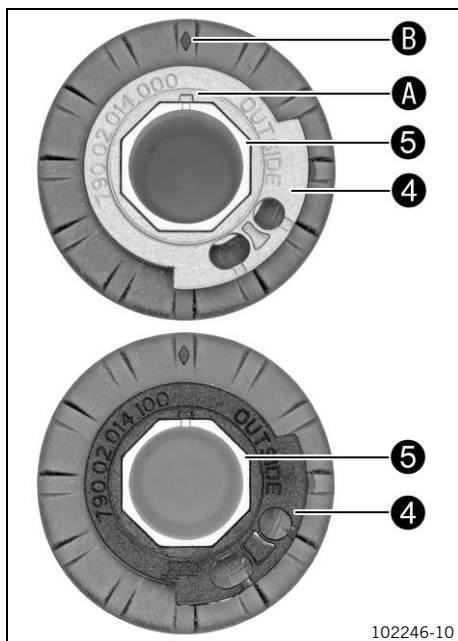

- Remove guide plate ④ from handle tube ⑤.
- Position the required guide plate on the grip tube.

Guideline

The label **OUTSIDE** must be visible. Marking **A** must be positioned at marking **B**.

Grey guide plate (79002014000)

Alternative 1

Black guide plate (79002014100)

i Info

The gray guide plate opens the throttle valve more slowly.
The black guide plate opens the throttle valve more quickly.
The gray guide plate is mounted upon delivery.

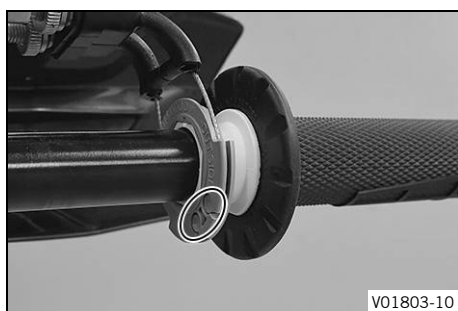

- Clean the outside of the handlebar and the inside of the grip tube. Mount the grip tube on the handlebar.
- Attach the throttle cables to the guide plate and route correctly.
- Position half-shells ③, mount and tighten screws ②.

Guideline

Screw, throttle grip	M6	5 Nm (3.7 lbf ft)
----------------------	----	-------------------

- Slide on sleeve ① and check the throttle grip for ease of movement.

Finishing work

- Check the play in the throttle cable. (📖 p. 136)

17.4 Changing the mapping (EXC-F SIX DAYS, XCF-W)



Warning

Voiding of the government approval for road use and the insurance coverage If the combination switch is mounted, the vehicle's road permit, if any, expires.

- Only operate the vehicle in closed-off areas remote from public road traffic if the combination switch is installed.



Info

The desired engine characteristic can be activated via the **MAP** button on the combination switch. The setting most recently selected is activated again when restarting.
The traction control can also be activated in each mapping using the **TC** button.
The mapping can also be changed during the ride.

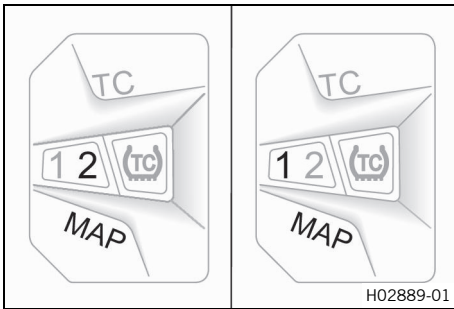

Activating STANDARD mapping:

- Press button **MAP** until LED 1 lights up.

Guideline

Engine speed	< 4,000 rpm
--------------	-------------

- ✓ STANDARD – balanced response

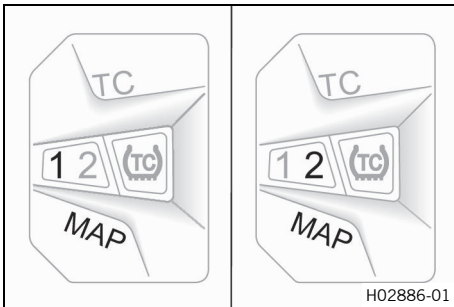

Activating ADVANCED mapping:

- Press button **MAP** until LED 2 lights up.

Guideline

Engine speed	< 4,000 rpm
--------------	-------------

- ✓ ADVANCED – direct response

17.5 Adjusting the idle speed ↩



Warning

Danger of accidents The engine may go out spontaneously if the idle speed is set too low.

- Set the idle speed to the specified value. (Your authorized KTM workshop will be glad to help.)

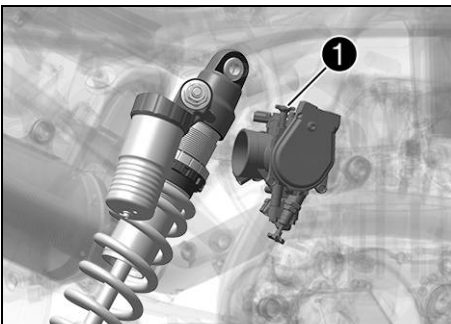

- Run the engine until warm.

- ✓ The cold start button is deactivated – The cold start button is in its basic position. (p. 21)



Danger

Danger of poisoning Exhaust gases are toxic and inhaling them may result in unconsciousness and death.

- Always make sure there is sufficient ventilation when running the engine.
- Use effective exhaust extraction when starting or running the engine in an enclosed space.

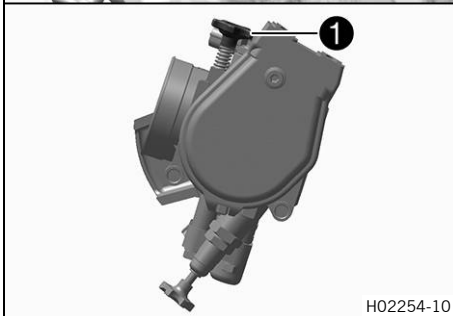

- Set the idle speed by turning idle speed adjusting screw ①.

Guideline

Idle speed	1,800 ... 1,900 rpm
------------	---------------------

Tachometer (45129075000)



Info

Turning counterclockwise lowers the idle speed.
Turning clockwise raises the idle speed.

17.6 Teaching the throttle valve position

- i Info** If the control unit detects that the throttle valve position at idle speed needs to be retaught, then the malfunction indicator lamp flashes 2x per second.

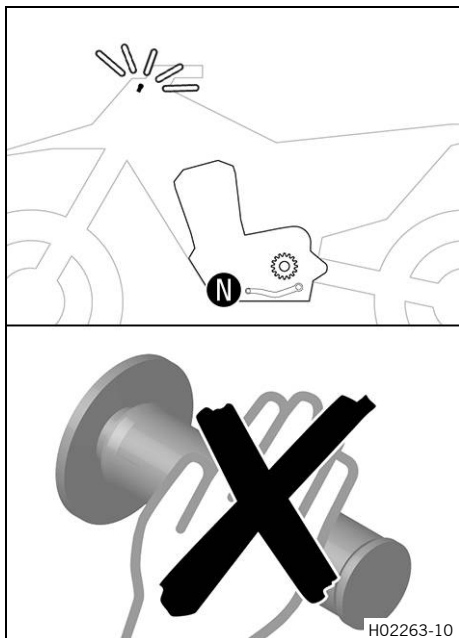

Danger

Danger of poisoning Exhaust gases are toxic and inhaling them may result in unconsciousness and death.

- Always make sure there is sufficient ventilation when running the engine.
- Use effective exhaust extraction when starting or running the engine in an enclosed space.

- Allow the vehicle to run at idle speed.
- ✓ The malfunction indicator lamp stops flashing once teaching is completed.



Info

If the engine becomes too hot, perform a cool-down ride at medium revs.

Then do not switch off the engine after this, but leave it running at idle speed until teaching is completed.

17.7 Checking the basic position of the shift lever

- i Info** When driving, the shift lever must not touch the rider's boot when in the basic position. When the shift lever keeps touching the boot, the transmission will be subject to an excessive load.

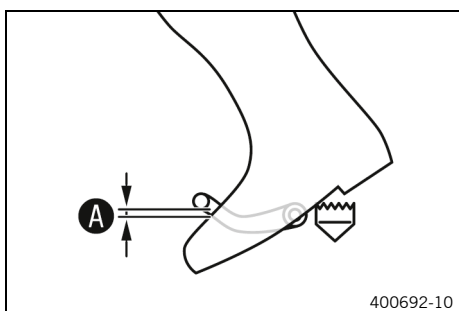

- Sit on the vehicle in the riding position and determine distance **A** between the upper edge of your boot and the shift lever.

Gap between the shift lever and the top of the boot	10 ... 20 mm (0.39 ... 0.79 in)
---	---------------------------------

- » If the distance does not meet specifications:
 - Adjust the basic position of the shift lever. (📖 p. 141)

17.8 Adjusting the basic position of the shift lever

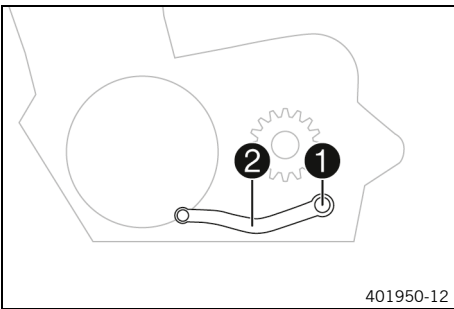

- Remove screw 1 with the washers and take off shift lever 2.

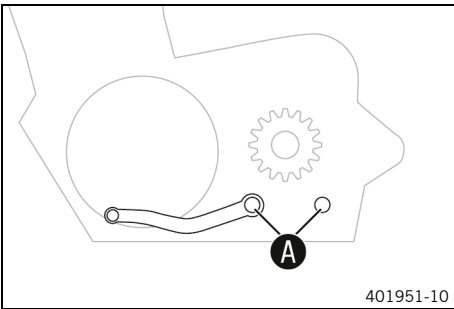

- Clean gear teeth A of the shift lever and shift shaft.
- Mount the shift lever on the shift shaft in the required position and engage gearing.

i Info
 The range of adjustment is limited.
 The shift lever must not come into contact with any other vehicle components during the shift procedure.

- Mount the screw with the washers and tighten.

Guideline

Screw, shift lever	M6	14 Nm (10.3 lbf ft) Loctite®243™
--------------------	----	--



18.1 Changing the fuel screen ↩



Danger

Fire hazard Fuel is highly flammable.

The fuel in the fuel tank expands when warm and can escape if overfilled.

- Do not fuel the vehicle in the vicinity of open flames or lit cigarettes.
- Switch off the engine for refueling.
- Make sure that no fuel is spilled; particularly not on hot parts of the vehicle.
- If any fuel is spilled, wipe it off immediately.
- Observe the specifications for refueling.



Warning

Danger of poisoning Fuel is poisonous and a health hazard.

- Avoid skin, eye and clothing contact with fuel.
- Immediately consult a doctor if you swallow fuel.
- Do not inhale fuel vapors.
- In case of skin contact, rinse the affected area with plenty of water.
- Rinse the eyes thoroughly with water, and consult a doctor in case of fuel contact with the eyes.
- Change your clothing in case of fuel spills on them.



Note

Environmental hazard Improper handling of fuel is a danger to the environment.

- Do not allow fuel to enter the groundwater, the soil, or the sewage system.

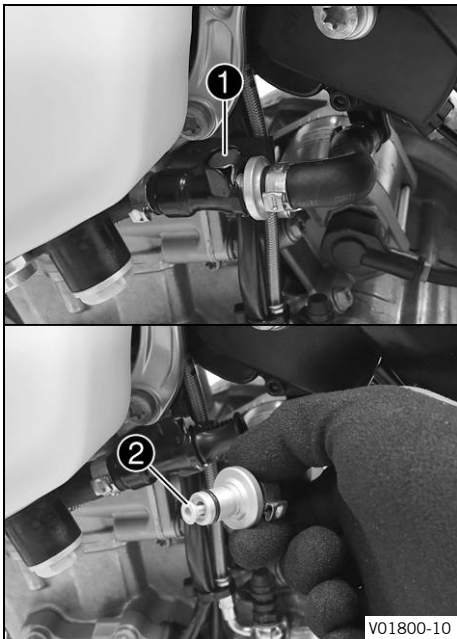

- Clean quick release coupling ① thoroughly with compressed air.



Info

Under no circumstances should dirt enter into the fuel line. Dirt in the fuel line clogs the injection valve!

- Disconnect the quick release coupling.



Info

Remaining fuel may flow out of the fuel hose.

- Pull fuel screen ② out of the connecting piece.
- Insert the new fuel screen all the way into the connecting piece.
- Spray silicone spray onto a lint-free cleaning cloth and lightly lubricate the O-ring of the quick-release coupling.

Silicone spray (📖 p. 167)

- Join the quick release coupling.



Danger

Danger of poisoning Exhaust gases are toxic and inhaling them may result in unconsciousness and death.

- Always make sure there is sufficient ventilation when running the engine.
- Use effective exhaust extraction when starting or running the engine in an enclosed space.

- Start the engine and check the response.



18.2 Checking the engine oil level

Condition

The engine is at operating temperature.

Preparatory work

- Stand the motorcycle upright on a horizontal surface.

Main work

- Check the engine oil level.

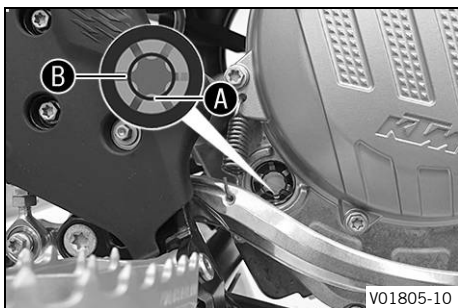

Info

After switching off the engine, wait one minute before checking the level.

The engine oil is at a level between lower edge **A** and the middle of level viewer **B**.

- » If the engine oil is not up to lower edge **A** of the level viewer:
 - Add engine oil. (📖 p. 146)



18.3 Changing the engine oil and oil filter, cleaning the oil screens 🛠️



Warning

Danger of scalding Engine and gear oil get very hot when the motorcycle is ridden.

- Wear suitable protective clothing and safety gloves.
- In the event of scalding, rinse the area affected immediately with lukewarm water.



Note

Environmental hazard Hazardous substances cause environmental damage.

- Dispose of oils, grease, filters, fuel, cleaning agents, brake fluid, etc., correctly and in compliance with the applicable regulations.



Info

Drain the engine oil with the engine at operating temperature.

Preparatory work

(EXC-F SIX DAYS, XCF-W)

- Remove the engine guard. (📖 p. 97)
- Park the motorcycle on a level surface.

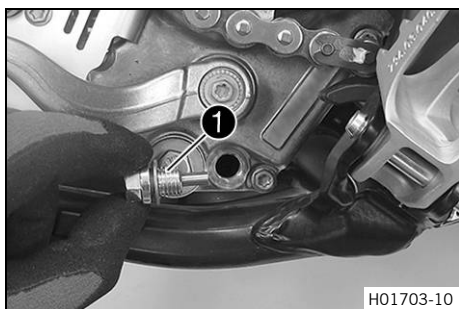

H01703-10

Main work

- Position an appropriate container under the engine.
- Remove oil drain plug ① with the magnet and seal ring.

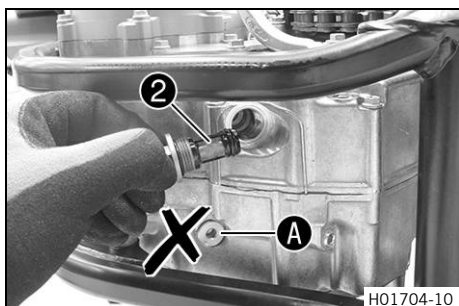

H01704-10

- Remove screw plug ② with the short oil screen and the O-rings.

i Info
Do not remove screw A.

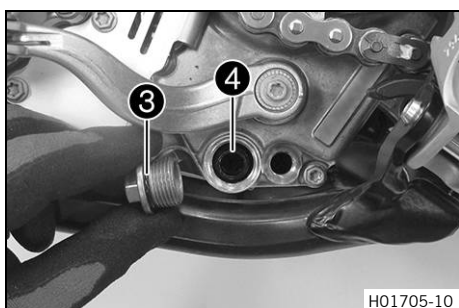

H01705-10

- Remove screw plug ③ with the long oil screen ④ and the O-rings.
- Allow the engine oil to drain completely.
- Thoroughly clean the parts and the sealing surfaces.

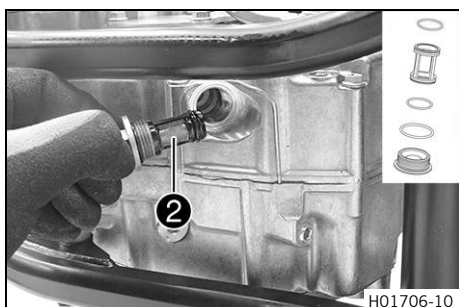

H01706-10

- Mount and tighten screw plug ② with the short oil screen and the O-rings.

Guideline

Screw plug, oil screen	M20x1.5	15 Nm (11.1 lbf ft)
------------------------	---------	---------------------

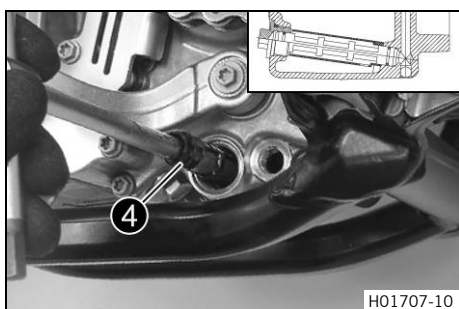

H01707-10

- Position long oil screen ④ with the O-rings on a pin wrench.
- Position the pin wrench through the drill hole of the screw plug in the opposite section of the engine case.
- Push the oil screen all the way into the engine case.

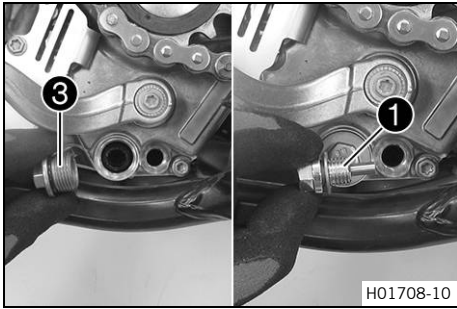

- Mount and tighten screw plug **3** with the O-ring.

Guideline

Screw plug, oil screen	M20x1.5	15 Nm (11.1 lbf ft)
------------------------	---------	---------------------

- Mount and tighten oil drain plug **1** with the magnet and a new seal ring.

Guideline

Oil drain plug with magnet	M12x1.5	20 Nm (14.8 lbf ft)
----------------------------	---------	---------------------

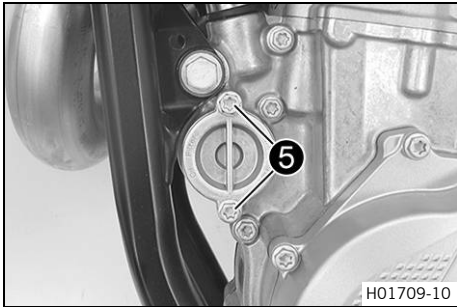

- Remove screws **5**. Take off the oil filter cover with the O-ring.

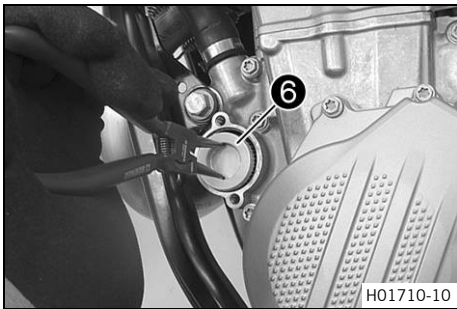

- Pull oil filter **6** out of the oil filter housing.

Lock ring plier (51012011000)

- Allow the engine oil to drain completely.
- Thoroughly clean the parts and the sealing surface.

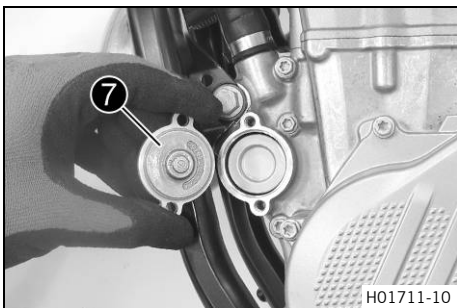

- Lay the motorcycle on its side and fill the oil filter housing to about 1/4 full with engine oil.
- Insert the new oil filter into the oil filter housing.
- Oil the O-ring of the oil filter cover and mount it together with oil filter cover **7**.
- Mount and tighten the screws.

Guideline

Screw, oil filter cover	M6	10 Nm (7.4 lbf ft)
-------------------------	----	--------------------

- Stand the motorcycle upright.
- Remove filler plug **8** with the O-ring, and fill up with engine oil.

Engine oil	1.2 l (1.3 qt.)	Engine oil (SAE 10W/50) (p. 164)
------------	-----------------	----------------------------------

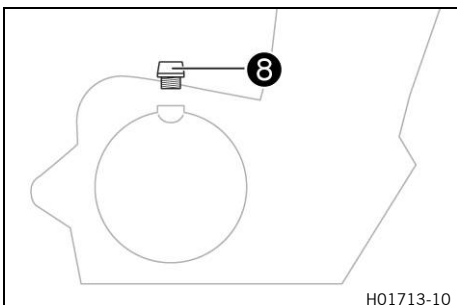

i Info Too little engine oil or poor-quality engine oil will result in premature wear of the engine.

- Mount and tighten the filler plug together with the O-ring.



Danger

Danger of poisoning Exhaust gases are toxic and inhaling them may result in unconsciousness and death.

- Always make sure there is sufficient ventilation when running the engine.
- Use effective exhaust extraction when starting or running the engine in an enclosed space.

- Start the engine and check it for leaks.

Finishing work

(EXC-F SIX DAYS, XCF-W)

- Install the engine guard. (📖 p. 98)
- Check the engine oil level. (📖 p. 143)

18.4 Adding engine oil



Info

Too little engine oil or poor-quality engine oil will result in premature wear of the engine.

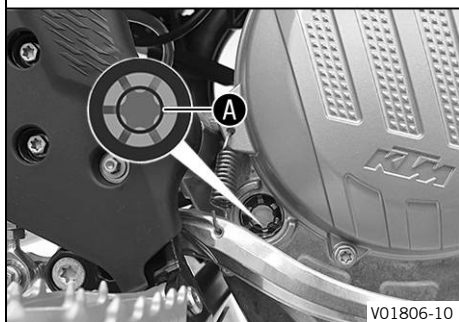
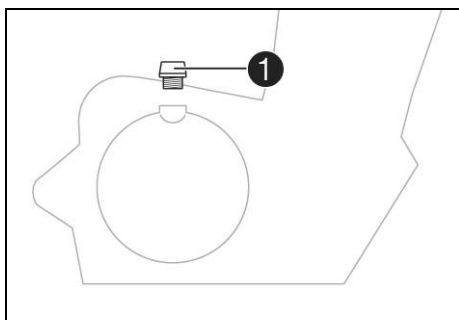

Main work

- Remove filler plug ① with the O-ring.
- Fill engine oil to the middle Ⓐ of the level viewer.

Engine oil (SAE 10W/50) (📖 p. 164)



Info

In order to achieve optimal engine oil performance, it is not advisable to mix different engine oils. KTM recommends changing the engine oil.

- Mount and tighten the filler plug together with the O-ring.



Danger

Danger of poisoning Exhaust gases are toxic and inhaling them may result in unconsciousness and death.

- Always make sure there is sufficient ventilation when running the engine.
- Use effective exhaust extraction when starting or running the engine in an enclosed space.

- Start the engine and check for leaks.

Finishing work

- Check the engine oil level. (📖 p. 143)

19.1 Cleaning the motorcycle

Note

Material damage Components become damaged or destroyed if a pressure cleaner is used incorrectly.

The high pressure forces water into the electrical components, connectors, throttle cables, and bearings, etc. Pressure which is too high causes malfunctions and destroys components.

- Do not direct the water jet directly on to electrical components, connectors, throttle cables or bearings.
- Maintain a minimum distance between the nozzle of the pressure cleaner and the component.
Minimum clearance 60 cm (23.6 in)



Note

Environmental hazard Hazardous substances cause environmental damage.

- Dispose of oils, grease, filters, fuel, cleaning agents, brake fluid, etc., correctly and in compliance with the applicable regulations.

i Info

To maintain the value and appearance of the motorcycle over a long period, clean it regularly. Avoid direct sunshine when cleaning the motorcycle.

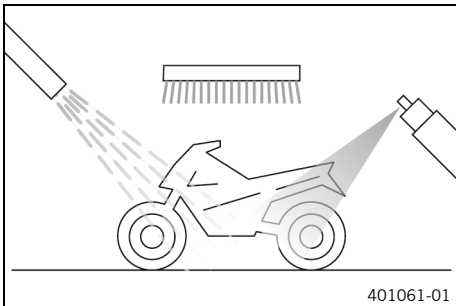

- Close off the exhaust system to keep water from entering.
- Remove the coarse dirt particles with a gentle water jet.
- Spray the heavily soiled parts with a normal commercial motorcycle cleaner and clean using a brush.

Motorcycle cleaner (📖 p. 166)

i Info

Use warm water containing normal motorcycle cleaner and a soft sponge. Never apply motorcycle cleaner to a dry vehicle; always rinse the vehicle with water first.

- After rinsing the motorcycle with a gentle spray of water, allow it to dry thoroughly.
- Remove the closure of the exhaust system.



Warning

Danger of accidents Moisture and dirt impair the brake system.

- Brake carefully several times to dry out and remove dirt from the brake linings and the brake discs.

- After cleaning, ride the vehicle a short distance until the engine warms up.

i Info

The heat produced causes water at inaccessible locations in the engine and on the brake system to evaporate.

- After the motorcycle has cooled down, lubricate all moving parts and pivot points.
- Clean the chain. (📖 p. 88)

- Treat bare metal (except for brake discs and the exhaust system) with a corrosion inhibitor.

Preserving materials for paints, metal and rubber (📖 p. 166)

- Treat all plastic parts and powder-coated parts with a mild cleaning and care product.

Special cleaner for glossy and matte paint finishes, metal and plastic surfaces (📖 p. 167)

(All EU models)

- Lubricate the steering lock.

Universal oil spray (📖 p. 167)

19.2 Checks and maintenance steps for winter operation

i Info

If you use the vehicle in winter, you must expect salt on the roads. You should therefore take precautions against aggressive road salt.

If the vehicle was operated in road salt, clean it with cold water after riding. Warm water would enhance the corrosive effects of salt.

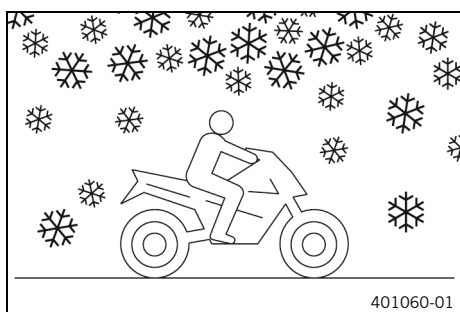

- Clean the motorcycle. (📖 p. 147)
- Clean brake system.

i Info

After **EVERY** trip on salted roads, thoroughly clean the brake calipers and brake linings, after they have cooled down and without removing them, with cold water and dry them carefully.

After riding on salted roads, thoroughly clean the vehicle with cold water and dry it well.

- Treat the engine, link fork, and all other bare or zinc-plated parts (except the brake discs) with a wax-based corrosion inhibitor.

i Info

Corrosion inhibitor must not come in contact with the brake discs as this would greatly reduce the braking force.

- Clean the chain. (📖 p. 88)

20.1 Storage



Warning

Danger of poisoning Fuel is poisonous and a health hazard.

- Avoid skin, eye and clothing contact with fuel.
- Immediately consult a doctor if you swallow fuel.
- Do not inhale fuel vapors.
- In case of skin contact, rinse the affected area with plenty of water.
- Rinse the eyes thoroughly with water, and consult a doctor in case of fuel contact with the eyes.
- Change your clothing in case of fuel spills on them.
- Keep fuels correctly in a suitable canister, and out of the reach of children.



Info

If you plan to garage the motorcycle for a longer period, perform the following steps or have them performed.

Before storing the motorcycle, check all parts for function and wear. If service, repairs, or replacements are necessary, you should do this during the storage period (less workshop overload). In this way, you can avoid long workshop waiting times at the start of the new season.

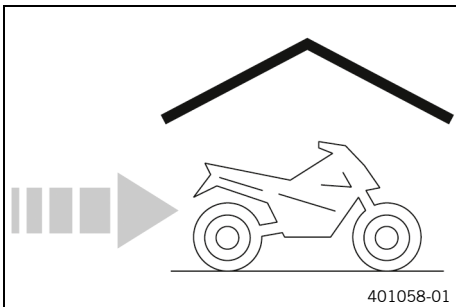

- When refueling for the last time before taking the motorcycle out of service, add fuel additive.

Fuel additive (📖 p. 166)

- Refuel. (📖 p. 47)
- Clean the motorcycle. (📖 p. 147)
- Change the engine oil and the oil filter, clean the oil screens. 🛠️ (📖 p. 143)
- Check the antifreeze and coolant level. (📖 p. 131)
- Check tire pressure. (📖 p. 117)
- Remove the 12-V battery. 🛠️ (📖 p. 119)
- Charge the 12-V battery. 🛠️ (📖 p. 121)

Guideline

Ideal charging and storage temperature of the lithium-ion battery	10 ... 20 °C (50 ... 68 °F)
---	-----------------------------

- Store the vehicle in a dry location that is not subject to large fluctuations in temperature.



Info

KTM recommends jacking up the motorcycle.

- Raise the motorcycle with the lift stand. (📖 p. 63)
- Preferably cover the motorcycle with a tarp or similar cover that is permeable to air. Do not use non-porous materials since they prevent humidity from escaping, thus causing corrosion.



Info

Avoid running the engine for a short time only. Since the engine cannot warm up properly, the water vapor produced during combustion condenses and causes valves and the exhaust system to rust.



20.2 Preparing for use after storage

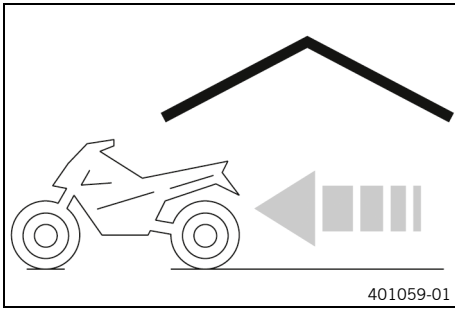

- Remove the motorcycle from the lift stand. (📖 p. 63)
- Install the 12-V battery. 🛠️ (📖 p. 120)
- Perform checks and maintenance measures when preparing for use. (📖 p. 43)
- Take a test ride.

Faults	Possible cause	Action
The engine cannot be cranked (starter motor)	Operating error	– Carry out start procedure. (📖 p. 43)
	12-V battery discharged	– Charge the 12-V battery. 🛠️ (📖 p. 121) – Check charging voltage. 🛠️ – Check the open-circuit current. 🛠️ – Check the stator winding of the alternator. 🛠️
	Main fuse blown	– Change the main fuse. (📖 p. 123)
	Starter relay defective	– Check the starter relay. 🛠️
	Starter motor defective	– Check the starter motor. 🛠️
The engine turns but does not start	Operating error	– Carry out start procedure. (📖 p. 43)
	Quick release coupling not joined	– Join the quick release coupling.
	Fuse 1 blown	– Change the fuses of individual electrical power consumers. (📖 p. 124)
	Fuse 4 blown	– Change the fuses of individual electrical power consumers. (📖 p. 124)
	Idle speed is not set correctly	– Adjust the idle speed. 🛠️ (📖 p. 139)
	Spark plug sooty or wet	– Clean and dry the spark plug and spark plug connector, or change if necessary.
	Plug gap of spark plug too wide	– Adjust plug gap. Guideline Spark plug electrode gap 1.0 mm (0.039 in)
	Ignition system defective	– Check the ignition system. 🛠️
	Short-circuit cable in wiring harness frayed, stop button or emergency OFF switch faulty	– Check the wiring harness. (visual check) – Check the electrical system.
Error in the electronic fuel injection	– Read out the fault memory using the KTM diagnostics tool. 🛠️	
Engine does not speed up	Error in the electronic fuel injection	– Read out the fault memory using the KTM diagnostics tool. 🛠️
	Ignition system defective	– Ignition coil - check the secondary winding. 🛠️ – Check the spark plug connector. 🛠️ – Check the stator winding of the alternator. 🛠️
Engine has too little power	Air filter heavily contaminated	– Clean the air filter and air filter box. 🛠️ (📖 p. 80)
	Fuel filter is very dirty	– Change the fuel filter. 🛠️
	Fuel screen is very dirty	– Change the fuel screen. 🛠️ (📖 p. 142)
	Error in the electronic fuel injection	– Read out the fault memory using the KTM diagnostics tool. 🛠️
	Exhaust system leaky, deformed or too little glass fiber yarn filling in the main silencer	– Check exhaust system for damage. – Change the glass fiber yarn filling of the main silencer. 🛠️ (📖 p. 84)
	Valve clearance too little	– Adjust the valve clearance. 🛠️









Faults	Possible cause	Action
Engine has too little power	Ignition system defective	<ul style="list-style-type: none"> – Ignition coil - check the secondary winding. 🛠️ – Check the spark plug connector. 🛠️ – Check the stator winding of the alternator. 🛠️
The engine dies during the trip	Lack of fuel	– Refuel. (📖 p. 47)
	Fuse 1 blown	– Change the fuses of individual electrical power consumers. (📖 p. 124)
	Fuse 4 blown	– Change the fuses of individual electrical power consumers. (📖 p. 124)
Engine overheats	Coolant level low in cooling system	<ul style="list-style-type: none"> – Check the cooling system for leaks. – Check the coolant level. (📖 p. 132)
	Insufficient airflow	– Switch off engine when stationary.
	Radiator fins very dirty	– Clean radiator fins.
	Foam formation in cooling system	<ul style="list-style-type: none"> – Drain the coolant. 🛠️ (📖 p. 133) – Refill the coolant. 🛠️ (📖 p. 134)
	Bent radiator hose	– Change the radiator hose. 🛠️
	Thermostat defective	<ul style="list-style-type: none"> – Check the thermostat. 🛠️ <p>Guideline Opening temperature: 70 °C (158 °F)</p>
	Defect in radiator fan system	<ul style="list-style-type: none"> – Check the radiator fan fuse. – Check fuse 4. – Check the radiator fan. 🛠️
Malfunction indicator lamp lights up or flashes	Error in the electronic fuel injection	<ul style="list-style-type: none"> – Stop motorcycle and identify faulty component using the blink code. – Check wiring for damage and electrical plug-in connectors for corrosion and damage. – Read out the fault memory using the KTM diagnostics tool. 🛠️
High oil consumption	Engine vent hose bent	– Route the vent hose without bends or replace it if necessary.
	Engine oil level too high	– Check the engine oil level. (📖 p. 143)
	Engine oil too thin (low viscosity)	– Change the engine oil and the oil filter, clean the oil screens. 🛠️ (📖 p. 143)
	Piston and cylinder worn	– Measure the piston/cylinder mounting clearance. 🛠️
12-V battery discharged	The 12-V battery is not being charged by the alternator	<ul style="list-style-type: none"> – Check charging voltage. 🛠️ – Check the stator winding of the alternator. 🛠️
	Unwanted electrical power consumer	– Check the open-circuit current. 🛠️
Values in combination instrument deleted (time, stop watch, lap times)	The combination instrument battery is empty	– Change combination instrument battery. (📖 p. 129)
The high beam, low beam, tail light, position light, and license plate lamp are not working	Fuse 2 blown	– Change the fuses of individual electrical power consumers. (📖 p. 124)





Faults	Possible cause	Action
The horn, brake light, turn signal, and radiator fan are not working	Fuse 3 blown	– Change the fuses of individual electrical power consumers. (📖 p. 124)



Info

The blink codes are only displayed by the derestricted version of the vehicle.

Blink code for malfunction indicator lamp	 02a Malfunction indicator lamp flashes 2x per second
Error level condition	Teaching of throttle valve position required
Blink code for malfunction indicator lamp	 02 Malfunction indicator lamp flashes 2x short
Error level condition	Crankshaft speed sensor – circuit fault
Blink code for malfunction indicator lamp	 06 Malfunction indicator lamp flashes 6x short
Error level condition	Throttle valve position sensor circuit A – input signal too low Throttle valve position sensor circuit A – input signal too high
Blink code for malfunction indicator lamp	 09 Malfunction indicator lamp flashes 9x short
Error level condition	Induction manifold pressure sensor, cylinder 1 – input signal too low Induction manifold pressure sensor cylinder 1 – input signal too high
Blink code for malfunction indicator lamp	 12 Malfunction indicator lamp flashes 1x long, 2x short
Error level condition	Coolant temperature sensor – input signal too low Coolant temperature sensor – input signal too high
Blink code for malfunction indicator lamp	 13 Malfunction indicator lamp flashes 1x long, 3x short
Error level condition	Intake air temperature sensor – input signal too low Intake air temperature sensor – input signal too high
Blink code for malfunction indicator lamp	 15 Malfunction indicator lamp flashes 1x long, 5x short
Error level condition	Tilt sensor – input signal too low Tilt sensor – input signal too high
Blink code for malfunction indicator lamp	 21 Malfunction indicator lamp flashes 2x long, 1x short
Error level condition	Battery voltage – input voltage too high

Blink code for malfunction indicator lamp	 22 Malfunction indicator lamp flashes 2x long, 2x short
Error level condition	Gear position sensor - input voltage too high Gear position sensor - input voltage too low
Blink code for malfunction indicator lamp	 33 Malfunction indicator lamp flashes 3x long, 3x short
Error level condition	Injector cylinder 1 - circuit fault
Blink code for malfunction indicator lamp	 37 Malfunction indicator lamp flashes 3x long, 7x short
Error level condition	Ignition coil 1, cylinder 1 - circuit fault
Blink code for malfunction indicator lamp	 41 Malfunction indicator lamp flashes 4x long, 1x short
Error level condition	Fuel pump relay - short circuit to ground or open circuit Fuel pump relay - input signal too low

23.1 Engine

Design	1-cylinder 4-stroke engine, water-cooled
Displacement (All 450 models)	449.9 cm ³ (27.455 cu in)
Displacement (All 500 models)	510.9 cm ³ (31.177 cu in)
Stroke (All 450 models)	63.4 mm (2.496 in)
Stroke (All 500 models)	72 mm (2.83 in)
Bore	95 mm (3.74 in)
Compression ratio	12.75:1
Idle speed	1,800 ... 1,900 rpm
Control	OHC, 4 valves controlled via rocker arm
Valve diameter, intake	40 mm (1.57 in)
Valve diameter, exhaust	33 mm (1.3 in)
Valve clearance	
Intake at: 20 °C (68 °F)	0.10 ... 0.15 mm (0.0039 ... 0.0059 in)
Exhaust at: 20 °C (68 °F)	0.12 ... 0.17 mm (0.0047 ... 0.0067 in)
Crankshaft bearing	2 cylinder roller bearing
Conrod bearing	Slide bearing
Piston pin bearing	No bearing bush – DLC coated piston pin
Pistons	Forged light alloy
Piston rings	1 compression ring, 1 oil scraper ring
Engine lubrication	Pressure circulation lubrication with 2 trochoidal pumps
Primary transmission	31:76
Clutch	Multidisc clutch in oil bath, hydraulically activated
Transmission ratio	
first-gear	14:36
second-gear	17:32
third-gear	19:28
fourth-gear	22:26
fifth-gear	23:24
sixth-gear	26:21
Alternator	12 V, 196 W
Ignition	Contactless controlled fully electronic ignition with digital ignition adjustment
Spark plug	NGK LZMAR8BI-10
Spark plug electrode gap	1.0 mm (0.039 in)
Cooling	Water cooling, permanent circulation of coolant by water pump
Starting aid	Starter motor

23.2 Engine tightening torques

Oil jet, piston cooling	M4	2 Nm (1.5 lbf ft)	Loctite®243™
Crankshaft speed sensor screw and cable retainer	M5	6 Nm (4.4 lbf ft)	Loctite®243™
Oil nozzle for clutch lubrication	M5	2.5 Nm (1.84 lbf ft)	
Oil nozzle for piston cooling	M5	2.5 Nm (1.84 lbf ft)	
Oil nozzle for rocker arm lubrication	M5	2.5 Nm (1.84 lbf ft)	
Oil nozzle for timing chain lubrication	M5	2.5 Nm (1.84 lbf ft)	
Screw, bearing retainer	M5	6 Nm (4.4 lbf ft)	Loctite®243™
Screw, clutch spring retainer	M5	6 Nm (4.4 lbf ft)	
Screw, gear position sensor	M5	5 Nm (3.7 lbf ft)	Loctite®243™
Screw, locking lever	M5	6 Nm (4.4 lbf ft)	Loctite®243™
Screw, stator	M5	6 Nm (4.4 lbf ft)	Loctite®2701™
Screw, suction pump cover	M5	6 Nm (4.4 lbf ft)	Loctite®243™
Nut, water pump impeller	M6	6 Nm (4.4 lbf ft)	Loctite®243™
Screw, alternator cover	M6	10 Nm (7.4 lbf ft)	
Screw, clutch cover	M6	10 Nm (7.4 lbf ft)	
Screw, clutch slave cylinder	M6	10 Nm (7.4 lbf ft)	
Screw, cylinder head	M6	10 Nm (7.4 lbf ft)	
Screw, engine case	M6	10 Nm (7.4 lbf ft)	
Screw, exhaust flange	M6	10 Nm (7.4 lbf ft)	Loctite®243™
Screw, fuel vapor retention system connection	M6	5 Nm (3.7 lbf ft)	Loctite®2701™
Screw, fuel vapor retention system lock	M6	5 Nm (3.7 lbf ft)	Loctite®243™
Screw, oil filter cover	M6	10 Nm (7.4 lbf ft)	
Screw, pressure pump cover	M6	10 Nm (7.4 lbf ft)	Loctite®243™
Screw, shift drum locating	M6	10 Nm (7.4 lbf ft)	Loctite®243™
Screw, shift lever	M6	14 Nm (10.3 lbf ft)	Loctite®243™
Screw, starter motor	M6	10 Nm (7.4 lbf ft)	
Screw, timing chain clip	M6	10 Nm (7.4 lbf ft)	Loctite®243™
Screw, timing chain tensioner	M6	10 Nm (7.4 lbf ft)	
Screw, timing chain tensioning rail	M6	10 Nm (7.4 lbf ft)	Loctite®243™

Screw, torque governor	M6	10 Nm (7.4 lbf ft) Loctite®243™
Screw, valve cover	M6	10 Nm (7.4 lbf ft)
Screw, water pump cover	M6	10 Nm (7.4 lbf ft)
Oil nozzle for conrod bearing lubrication	M6x0.75	2.5 Nm (1.84 lbf ft)
Plug, oil channel	M7	9 Nm (6.6 lbf ft) Loctite®243™
Screw, camshaft retaining bracket	M7x1	15 Nm (11.1 lbf ft)
Screw, rocker arm bearing	M7x1	15 Nm (11.1 lbf ft)
Crankshaft clamp screw plug	M8	10 Nm (7.4 lbf ft)
Plug, timing chain tensioner	M8	8 Nm (5.9 lbf ft)
Plug, oil channel	M10	15 Nm (11.1 lbf ft) Loctite®243™
Screw, engine sprocket	M10	60 Nm (44.3 lbf ft) Loctite®2701™
Spark plug	M10x1	10 ... 12 Nm (7.4 ... 8.9 lbf ft)
Engine coolant temperature sensor	M10x1.25	12 Nm (8.9 lbf ft)
Screw, cylinder head	M10x1.25	1st stage 10 Nm (7.4 lbf ft) 2nd stage 30 Nm (22.1 lbf ft) 3rd stage 50 Nm (36.9 lbf ft) Collar and thread oiled
Nut, rotor	M12x1	60 Nm (44.3 lbf ft) Thread, oiled with engine oil/cone degreased
Oil drain plug with magnet	M12x1.5	20 Nm (14.8 lbf ft)
Screw plug, oil pressure control valve	M12x1.5	20 Nm (14.8 lbf ft)
Nut, inner clutch hub	M18x1.5	100 Nm (73.8 lbf ft) Loctite®243™
Nut, primary gear wheel	M20LHx1.5	100 Nm (73.8 lbf ft) Loctite®243™
Screw plug, oil screen	M20x1.5	15 Nm (11.1 lbf ft)

23.3 Capacities

23.3.1 Engine oil

Engine oil	1.2 l (1.3 qt.)	Engine oil (SAE 10W/50) (📖 p. 164)
------------	-----------------	---------------------------------------

23.3.2 Coolant

Coolant	1.2 l (1.3 qt.)	Coolant (📖 p. 164)
---------	-----------------	--------------------

23.3.3 Fuel

Total fuel tank capacity, approx. (All EU models)	9 l (2.4 US gal)	Super unleaded (ROZ 95) (📖 p. 165)
--	------------------	---------------------------------------

Total fuel tank capacity, approx. (XCF-W)	8.5 l (2.25 US gal)	Super unleaded (ROZ 95) ( p. 165)
Fuel reserve, approx.	1.5 l (1.6 qt.)	

23.4 Chassis

Frame	Central tube frame made of chrome molybdenum steel tubing
Fork	WPXPLOR OC
Suspension travel	
front	300 mm (11.81 in)
rear	310 mm (12.2 in)
Fork offset	22 mm (0.87 in)
Shock absorber	WP XPLOR PDS
Brake system	Disc brakes, floating brake calipers
Brake discs - diameter	
front	260 mm (10.24 in)
rear	220 mm (8.66 in)
Brake discs - wear limit (EXC-F EU, XCF-W)	
front	2.5 mm (0.098 in)
rear	3.5 mm (0.138 in)
Brake discs - wear limit (EXC-F SIX DAYS EU)	
front	2.5 mm (0.098 in)
rear	3.7 mm (0.146 in)
Offroad tire pressure	
front	1.0 bar (15 psi)
rear	1.0 bar (15 psi)
Street tire pressure (XCF-W)	
front	2.0 bar (29 psi)
rear	2.0 bar (29 psi)
Final drive (450 EXC-F EU, 450 EXC-F SIX DAYS EU)	14:52 (13:52)
Final drive (All 500 models)	14:50 (13:50)
Final drive (XCF-W)	14:48
Chain	5/8 x 1/4"
Rear sprockets available	48, 50, 52
Steering head angle	63.5°
Wheelbase	1,482 ± 10 mm (58.35 ± 0.39 in)
Seat height unloaded	960 mm (37.8 in)
Ground clearance unloaded	355 mm (13.98 in)
Weight without fuel, approx. (450 EXC-F EU)	105.5 kg (232.6 lb.)
Weight without fuel, approx. (500 EXC-F EU)	105.6 kg (232.8 lb.)
Weight without fuel, approx. (450 EXC-F SIX DAYS EU)	106 kg (234 lb.)
Weight without fuel, approx. (500 EXC-F SIX DAYS EU)	106 kg (234 lb.)
Weight without fuel, approx. (XCF-W)	109.5 kg (241.4 lb.)
Maximum permissible front axle load	145 kg (320 lb.)

Maximum permissible rear axle load	190 kg (419 lb.)
Maximum permissible overall weight	335 kg (739 lb.)

23.5 Electrical system

12-V battery	HJTZ5S-FP-C	Lithium-ion battery Battery voltage: 12 V Nominal capacity: 2.0 Ah Maintenance-free
Combination instrument battery	CR 2430	Battery voltage: 3 V
Fuse	75011088005	5 A
Fuse	75011088010	10 A
Fuse	58011109120	20 A
Headlight	HS1 / socket PX43t	12 V 35/35 W
Position light	W5W / socket W2.1x9.5d	12 V 5 W
Indicator lamps	W2.3W / socket W2x4.6d	12 V 2.3 W
Turn signal (All EU models)	R10W / socket BA15s	12 V 10 W
Brake/tail light	LED	
License plate lamp	LED	

23.6 Tires

Validity	Front tire	Rear tire
(EXC-F EU)	80/100 - 21 M/C 51M TT MAXXIS Maxx Enduro	140/80 - 18 M/C 70R M+S TT MAXXIS Maxx Enduro
(XCF-W)	90/90 - 21 54M TT Dunlop GEOMAX AT81F	110/100 - 18 64M TT Dunlop GEOMAX AT81
(EXC-F SIX DAYS EU)	90/90 - 21 M/C 54M M+S TT Metzeler MCE 6 Days Extreme	140/80 - 18 M/C 70M M+S TT Metzeler MCE 6 Days Extreme

The tires specified represent one of the possible series production tires. For alternative manufacturers, if any, contact an authorized dealer or qualified tire dealership. If local road approval regulations apply, these and the respective technical specifications must be observed. Additional information is available in the Service section under:
KTM.COM

23.7 Fork

Fork article number	0797C168V401000
Fork	WPXPLOR OC
Compression damping	
Comfort	18 clicks
Standard	15 clicks
Sport	12 clicks
Rebound damping	
Comfort	18 clicks
Standard	15 clicks

Sport	12 clicks	
Spring preload – preload adjuster		
Comfort	+0	
Standard	+0	
Sport	+3	
Spring length with preload spacer(s)	474 mm (18.66 in)	
Spring rate		
Weight of rider: 65 ... 75 kg (143 ... 165 lb.)	4.4 N/mm (25.1 lb/in)	
Weight of rider: 75 ... 85 kg (165 ... 187 lb.)	4.6 N/mm (26.3 lb/in)	
Weight of rider: 85 ... 95 kg (187 ... 209 lb.)	4.8 N/mm (27.4 lb/in)	
Fork length	928 mm (36.54 in)	
Fork oil per fork leg	636 ± 10 ml (21.5 ± 0.34 fl. oz.)	Fork oil (SAE 4) (48601166S1) (📖 p. 165)

23.8 Shock absorber

Shock absorber article number	0797C469V305000	
Shock absorber	WP XPLOR PDS	
Low-speed compression damping		
Comfort	18 clicks	
Standard	15 clicks	
Sport	12 clicks	
High-speed compression damping		
Comfort	2.5 turns	
Standard	2 turns	
Sport	1 turn	
Rebound damping		
Comfort	18 clicks	
Standard	15 clicks	
Sport	12 clicks	
Spring preload	10 mm (0.39 in)	
Spring rate		
Weight of rider: 65 ... 75 kg (143 ... 165 lb.)	60 ... 66 N/mm (343 ... 377 lb/in)	
Weight of rider: 75 ... 85 kg (165 ... 187 lb.)	63 ... 69 N/mm (360 ... 394 lb/in)	
Weight of rider: 85 ... 95 kg (187 ... 209 lb.)	66 ... 72 N/mm (377 ... 411 lb/in)	
Spring length	225 mm (8.86 in)	
Gas pressure	10 bar (145 psi)	
Static sag	37 mm (1.46 in)	
Riding sag	110 mm (4.33 in)	
Fitted length	415 mm (16.34 in)	
Damper oil	Shock absorber fluid (SAE 2.5) (50180751S1) (📖 p. 165)	

23.9 Chassis tightening torques

Remaining screws, chassis	EJOT PT® K60x25-Z	2 Nm (1.5 lbf ft)	
Screw, combination switch (EXC-F SIX DAYS, XCF-W)	EJOT PT® K50x18	2 Nm (1.5 lbf ft)	
Screw, intake air temperature sensor (All EU models)	EJOT DELTA PT® 45x12-Z	0.7 Nm (0.52 lbf ft)	
Screw, pressure regulator	EJOT PT® K60x25-Z	2.3 Nm (1.7 lbf ft)	
Screw, seat fixing	EJOT EJOFORM PT® K60x23/18	2.5 Nm (1.84 lbf ft)	
Screw, emergency OFF switch	M4	1 Nm (0.7 lbf ft)	
Screw, fixed grip	M4	5 Nm (3.7 lbf ft)	Loctite®243™
Spoke nipple, front wheel	M4.5	6 Nm (4.4 lbf ft)	
Spoke nipple, rear wheel	M4.5	6 Nm (4.4 lbf ft)	
Remaining nuts, chassis	M5	5 Nm (3.7 lbf ft)	
Remaining screws, chassis	M5	5 Nm (3.7 lbf ft)	
Screw, battery terminal	M5	2.5 Nm (1.84 lbf ft)	
Screw, intake air temperature sensor (XCF-W)	M5	2.7 Nm (1.99 lbf ft)	
Screw, light switch	M5	1 Nm (0.7 lbf ft)	
Screw, turn signal switch	M5	1 Nm (0.7 lbf ft)	
Nut, starter motor	M6	4 Nm (3 lbf ft)	
Remaining nuts, chassis	M6	10 Nm (7.4 lbf ft)	
Remaining screws, chassis	M6	10 Nm (7.4 lbf ft)	
Screw, ball joint of push rod on foot brake cylinder	M6	10 Nm (7.4 lbf ft)	Loctite®243™
Screw, chain sliding guard	M6	10 Nm (7.4 lbf ft)	Loctite®243™
Screw, front brake disc	M6	14 Nm (10.3 lbf ft)	Loctite®243™
Screw, rear brake disc	M6	14 Nm (10.3 lbf ft)	Loctite®243™
Screw, throttle grip	M6	5 Nm (3.7 lbf ft)	
Fuel connection on fuel pump	M8	15 Nm (11.1 lbf ft)	
Nut, foot brake lever stop	M8	20 Nm (14.8 lbf ft)	
Nut, rear sprocket screw	M8	35 Nm (25.8 lbf ft)	Loctite®2701™
Nut, rim lock	M8	12 Nm (8.9 lbf ft)	
Remaining nuts, chassis	M8	25 Nm (18.4 lbf ft)	
Remaining screws, chassis	M8	25 Nm (18.4 lbf ft)	
Screw, bottom triple clamp (EXC-F SIX DAYS EU)	M8	15 Nm (11.1 lbf ft)	
Screw, bottom triple clamp (EXC-F EU, XCF-W)	M8	15 Nm (11.1 lbf ft)	
Screw, chain sliding piece	M8	15 Nm (11.1 lbf ft)	
Screw, engine brace on engine	M8x20	25 Nm (18.4 lbf ft)	Loctite®243™

Screw, engine brace on frame	M8x15	25 Nm (18.4 lbf ft) Loctite®2701™
Screw, fork stub	M8	15 Nm (11.1 lbf ft)
Screw, front brake caliper	M8	25 Nm (18.4 lbf ft) Loctite®243™
Screw, handlebar clamp	M8	20 Nm (14.8 lbf ft)
Screw, manifold	M8	15 Nm (11.1 lbf ft)
Screw, side stand attachment	M8	33 Nm (24.3 lbf ft) Loctite®2701™
Screw, subframe bottom	M8	30 Nm (22.1 lbf ft) Loctite®2701™
Screw, subframe top	M8	35 Nm (25.8 lbf ft) Loctite®2701™
Screw, top steering stem (EXC-F SIX DAYS EU)	M8	17 Nm (12.5 lbf ft) Loctite®243™
Screw, top steering stem (EXC-F EU, XCF-W)	M8	20 Nm (14.8 lbf ft)
Screw, top triple clamp (EXC-F SIX DAYS EU)	M8	17 Nm (12.5 lbf ft)
Screw, top triple clamp (EXC-F EU, XCF-W)	M8	20 Nm (14.8 lbf ft)
Engine attachment bolt	M10	60 Nm (44.3 lbf ft)
Remaining nuts, chassis	M10	45 Nm (33.2 lbf ft)
Remaining screws, chassis	M10	45 Nm (33.2 lbf ft)
Screw, handlebar holder	M10	40 Nm (29.5 lbf ft) Loctite®243™
Nut, fuel pump fixation	M12	15 Nm (11.1 lbf ft)
Screw, bottom shock absorber	M12	80 Nm (59 lbf ft) Loctite®2701™
Screw, top shock absorber	M12	80 Nm (59 lbf ft) Loctite®2701™
Nut, fork pivot	M16x1.5	100 Nm (73.8 lbf ft)
Nut, rear wheel spindle	M20x1.5	80 Nm (59 lbf ft)
Screw, front wheel spindle	M20x1.5	35 Nm (25.8 lbf ft)
Screw, top steering head	M20x1.5	12 Nm (8.9 lbf ft)
Screw-in fitting, cooling system	M24x1.5	18 Nm (13.3 lbf ft) Loctite®243™

Brake fluid DOT 4 / DOT 5.1

Standard/classification

- DOT

Guideline

- Use only brake fluid that complies with the specified standard (see specifications on the container) and that exhibits the corresponding properties.

Recommended supplier

Castrol

- REACT PERFORMANCE DOT 4

MOTOREX®

- Brake Fluid DOT 5.1

Coolant

Guideline

- Only use high-grade, silicate-free coolant with corrosion inhibitor additive for aluminum motors. Low grade and unsuitable antifreeze causes corrosion, deposits and frothing.
- Do not use pure water as only coolant is able to meet the requirements needed in terms of corrosion protection and lubrication properties.
- Only use coolant that complies with the requirements stated (see specifications on the container) and that has the relevant properties.

Antifreeze protection to at least	-25 °C (-13 °F)
-----------------------------------	-----------------

The mixture ratio must be adjusted to the necessary antifreeze protection. Use distilled water if the coolant needs to be diluted.

The use of premixed coolant is recommended.

Observe the coolant manufacturer specifications for antifreeze protection, dilution and miscibility (compatibility) with other coolants.

Recommended supplier

MOTOREX®

- COOLANT M3.0

Engine oil (SAE 10W/50)

Standard/classification

- JASO T903 MA2 (📖 p. 168)
- SAE (📖 p. 168) (SAE 10W/50)

Guideline

- Use only engine oils that comply with the specified standards (see specifications on the container) and that possess the corresponding properties.

Fully synthetic engine oil

Recommended supplier

MOTOREX®

- Cross Power 4T

Fork oil (SAE 4) (48601166S1)**Standard/classification**

- SAE (📖 p. 168) (SAE 4)

Guideline

- Use only oils that comply with the specified standards (see specifications on the container) and that exhibit the corresponding properties.

Shock absorber fluid (SAE 2.5) (50180751S1)**Standard/classification**

- SAE (📖 p. 168) (SAE 2.5)

Guideline

- Use only oils that comply with the specified standards (see specifications on the container) and that exhibit the corresponding properties.

Super unleaded (ROZ 95)**Standard/classification**

- DIN EN 228 (ROZ 95)

Guideline

- Only use super unleaded fuel that matches or is equivalent to the specified standard.
- Fuel with an ethanol content of up to 10% (E10 fuel) is safe to use.

**Info**

Do **not** use fuel containing methanol (e.g., M15, M85, M100) or more than 10% ethanol (e.g., E15, E25, E85, E100).

Air filter cleaner

Recommended supplier

MOTOREX®

- Racing Bio Dirt Remover

Chain cleaner

Recommended supplier

MOTOREX®

- Chain Clean

Fuel additive

Recommended supplier

MOTOREX®

- Fuel Stabilizer

High viscosity grease

Recommended supplier

SKF®

- LGHB 2

Long-life grease

Recommended supplier

MOTOREX®

- Bike Grease 2000

Motorcycle cleaner

Recommended supplier

MOTOREX®

- Moto Clean

Off-road chain spray

Recommended supplier

MOTOREX®

- Chainlube Offroad

Oil for foam air filter

Recommended supplier

MOTOREX®

- Racing Bio Liquid Power

Preserving materials for paints, metal and rubber

Recommended supplier

MOTOREX®

- Moto Protect

Silicone spray

Recommended supplier

MOTOREX®

- Silicone Spray

Special cleaner for glossy and matte paint finishes, metal and plastic surfaces

Recommended supplier

MOTOREX®

- Quick Cleaner

Universal oil spray

Recommended supplier

MOTOREX®

- Joker 440 Synthetic

JASO T903 MA2

Different technical development directions required a separate specification for motorcycles – the **JASO T903 MA2** standard.

Earlier, engine oils from the automobile industry were used for motorcycles because there was no separate motorcycle specification.

Whereas long service intervals are demanded for automobile engines, the focus for motorcycle engines is on high performance at high engine speeds.

In most motorcycle engines, the transmission and clutch are lubricated with the same oil.

The **JASO T903 MA2** standard meets these special requirements.

SAE

The SAE viscosity classes were defined by the Society of Automotive Engineers and are used for classifying oils according to their viscosity. The viscosity describes only one property of oil and says nothing about quality.



OBD	On-board diagnosis	Vehicle system, which monitors the specified parameters of the vehicle electronics
-----	--------------------	--

28 LIST OF ABBREVIATIONS

Art. no.	Article number
ca.	circa
cf.	compare
e.g.	for example
etc.	et cetera
i.a.	inter alia
no.	number
poss.	possibly



29.1 Yellow and orange symbols

Yellow and orange symbols indicate an error condition that requires prompt intervention. Active driving aids are also represented by yellow or orange symbols.

	Malfunction indicator lamp lights up/flashes yellow – The OBD has detected an error in the vehicle electronics. Come safely to a halt, and contact an authorized KTM workshop.
	The fuel level warning lamp lights up yellow – The fuel level has reached the reserve mark.

29.2 Green and blue symbols

Green and blue symbols reflect information.

	The high beam indicator lamp lights up blue – The high beam is switched on.
	Turn signal indicator lamp flashes green – The turn signal is switched on.

1	
12-V battery	
charging	121
installing	120
removing	119
starting power	39
A	
Air filter	
cleaning	80
installing	80
removing	79
Air filter box	
cleaning	80
Air filter box cover	
installing	79
preparing for securing	81
removing	78
Antifreeze	
checking	131
Auxiliary substances	11
B	
Basic chassis setting	
rider's weight, checking with	52
Blink code	154-155
Brake discs	
checking	99
Brake fluid	
of front brake, adding	100
of rear brake, adding	108
Brake fluid level	
of front brake, checking	100
rear brake, checking	108
Brake linings	
front brake, checking	102
of the front brake, changing	102
of the rear brake, changing	110
rear brake, checking	109
Brake system	99-112
C	
Capacity	
coolant	134-135, 158
engine oil	145, 158
fuel	48, 158-159
Chain	
checking	91
cleaning	88
Chain guide	
checking	91
Chain tension	
adjusting	90
checking	89
Characteristic map of the throttle response	
adjusting	137
Clutch	
fluid level, checking/correcting	95
fluid, changing	96
Clutch lever	16
basic position, adjusting	95
Cold start button	21
Combination instrument	
combination instrument battery, changing	129
kilometers or miles, setting	25
lap time, viewing	27
overview	25
setting	26
setting the clock	26
Compression damping	
fork, adjusting	58
Coolant	
antifreeze and coolant level, checking	131
draining	133
level, checking	132
refilling	134
Cooling system	131
Customer service	11
D	
Defined use	7
Diagnostics connector	130
Difficult operating conditions	39
dry sand	39
high temperatures	41
low temperature	42
muddy surfaces	41
slow speed	41
snow	42
wet sand	40
wet surfaces	41
E	
Emergency OFF switch	18
Engine	
running-in	38
Engine guard	
installing	98
removing	97
Engine number	15

Engine oil	
adding	146
changing	143
Engine oil level	
checking	143
Engine sprocket	
checking	91
Environment	9
F	
Figures	11
Filling up	
fuel	47
Foot brake lever	22
basic position, adjusting	107
free travel, checking	106
Fork legs	
basic setting, checking	57
bleeding	63
dust boots, cleaning	64
installing	66
removing	65
spring preload, adjusting	59
Fork protector	
installing	65
removing	64
Frame	
checking	93
Front fender	
installing	75
removing	74
Front wheel	
installing	114
removing	113
Fuel screen	
changing	142
Fuel tank	
installing	86
removing	85
Fuel tank filler cap	
closing	20
opening	20
Fuel, oils, etc.	11
Fuse	
main fuse, changing	123
of individual electrical power consumers, changing	124
H	
Hand brake lever	16
basic position, adjusting	99
Handlebar position	60
adjusting	60
Headlight	
range, adjusting	128
Headlight bulb	
changing	126
Headlight mask with headlight	
installing	126
removing	125
Headlight setting	
checking	127
High-speed compression damping	
shock absorber, adjusting	53
Horn button	17
I	
Idle speed	
adjusting	139
Idle speed adjusting screw	21
Implied warranty	11
Intended use	7
K	
Key number	15
L	
Light switch	17
Link fork	
checking	93
Lower triple clamp	
installing	68, 70
removing	67-68
Low-speed compression damping	
shock absorber, adjusting	52
M	
Main fuse	
changing	123
Main silencer	
glass fiber yarn filling, changing	84
installing	82
removing	81
spark arrestor, cleaning	82
Manufacturer warranty	11
Mapping	
changing	138
Misuse	7
Motorcycle	
cleaning	147
lift stand, removing from	63
raising with lift stand	63

O		Spoke tension	
Oil filter		checking	118
changing	143	Start button	18
Oil screens		Starting	43
cleaning	143	Starting power of lithium-ion batteries at low temperatures	39
Overview of indicator lamps	19	Steering	
Owner's Manual	10	locking	23
P		unlocking	24
Play in throttle cable		Steering head bearing	
adjusting	136	lubricating	74
checking	136	Steering head bearing play	
Preparing for use		adjusting	73
advice on preparing for first use	37	checking	72
after storage	150	Stop button	16
checks and maintenance measures when preparing for use	43	Storage	149-150
Protective clothing	9	T	
R		Technical accessories	11
Rear sprocket		Technical data	
checking	91	capacities	158
Rear wheel		chassis	159
installing	115	chassis tightening torques	162
removing	114	electrical system	160
Rebound damping		engine	156
fork, adjusting	58	engine tightening torques	157
shock absorber, adjusting	54	fork	160
Riding sag		shock absorber	161
adjusting	57	tires	160
Rubber grip		Throttle cable routing	
checking	94	checking	93
S		Throttle grip	16
Safe operation	8	Throttle valve position	
Seat		teaching	140
mounting	77	Tire condition	
removing	77	checking	117
Service	11	Tire pressure	
Service schedule	49-51	checking	117
Shift lever	22	Traction control	
basic position, adjusting	141	activating	44
basic position, checking	140	Transporting	47
Shock absorber		Troubleshooting	151-153
installing	76	Turn signal bulb	
removing	76	changing	128
riding sag, checking	55	Turn signal switch	18
spring preload, adjusting	56	Type label	14
static sag, checking	55	V	
Side stand	22	Vehicle identification number	14
Spare parts	11	View of vehicle	
		front left	12

rear right 13

W

Winter operation

checks and maintenance steps 148

Work rules 9



3214649en

07.04.2022

