

125 DUKE

ART. NO. 3214868EN



Perform the work described in these setup instructions before the vehicle is delivered to the customer.

Read the setup instructions in their entirety before beginning work.

All specifications contained herein are non-binding. KTM Sportmotorcycle GmbH specifically reserves the right to modify or delete technical specifications, prices, colors, forms, materials, services, designs, equipment, etc., without prior notice and without specifying reasons, to adapt these to local conditions, as well as to stop production of a particular model without prior notice. KTM accepts no liability for delivery options, deviations from figures and descriptions, misprints, and other errors. The models portrayed partly contain special equipment that does not belong to the regular scope of supply.

These setup instructions were written to correspond to the latest state of this model series. We reserve the right to make modifications in the interest of technical advancement without at the same time updating these setup instructions.

We shall not provide a description of general workshop methods. Likewise, safety rules that apply in a workshop are not specified here. It is assumed that the work will be performed by a fully trained mechanic.

© 2023 KTM Sportmotorcycle GmbH, Mattighofen Austria

All rights reserved

Reproduction, even in part, as well as copying of all kinds, is permitted only with the express written permission of the copyright owner.



ISO 9001(12 100 6061)

KTM applies quality assurance processes that lead to the highest possible product quality as defined in the ISO 9001 international quality management standard.

Issued by: TÜV Management Service

REG.NO. 12 100 6061

KTM Sportmotorcycle GmbH
Stallhofnerstraße 3
5230 Mattighofen, Austria

This document is valid for the following models:

- 125 DUKE EU (F4003W1, F4003W2)
- 125 DUKE 2 EU (F4003W5, F4003W6)
- 125 DUKE B.D. EU (F4003W3, F4003W4)
- 125 DUKE JP (F4086W3, F4086W4)
- 125 DUKE UK (F4022W3, F4022W4)
- 125 DUKE 2 UK (F4022W5, F4022W6)



3214868en

03.05.2023

1 MEANS OF REPRESENTATION

1.1 Symbols used

The meaning of specific symbols is described below.



Indicates an expected reaction (e.g. of a work step or a function).



Indicates an unexpected reaction (e.g. of a work step or a function).



Indicates a page reference (more information is provided on the specified page).



Indicates information with more details or tips.



Indicates the result of a testing step.



Indicates a voltage measurement.



Indicates a current measurement.



Indicates a resistance measurement.



Indicates the end of an activity including potential rework.

1.2 Formats used

The typographical formats used in this document are explained below.

Proprietary name

Indicates a proprietary name.

Name®

Indicates a protected name.

Brand™

Indicates a brand available on the open market.

Underlined terms

Refer to technical details of the vehicle or indicate technical terms, which are explained in the glossary.

2.1 Transport mode

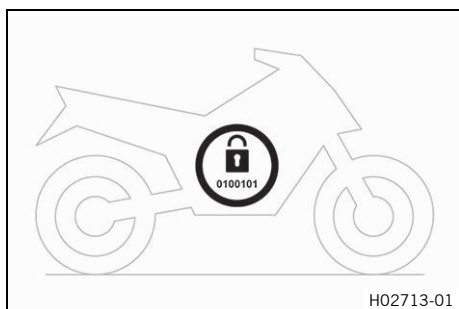

This vehicle was blocked for transport in the software. To operate the vehicle, the vehicle electronics must be enabled. This process is conducted during initial setup in KTM Dealer.net. Enabling ensures that the initial setup in KTM Dealer.net is documented.

Enabling can be performed either temporarily, e.g. for a test ride, or permanently for vehicle handover.

i Info

Make sure that the vehicle is permanently enabled before handing it over to the customer.

2.2 Diagnostics connector

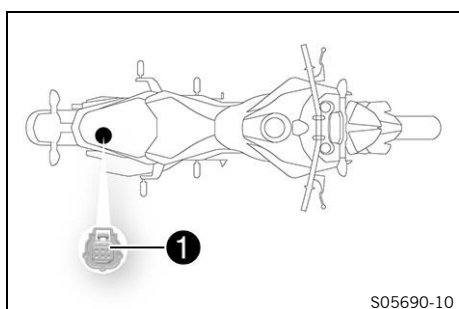

Diagnostics connector **1** is located under the passenger seat.

2.3 Unpacking and setting up the vehicle

Preliminary work

- Remove the box.



Main work

- Remove the adhesive tape in the upper area of the motorcycle.



- Roll down the film at the sides.

i Info

To avoid damaging the motorcycle during unpacking, leave the other films on the vehicle until you have finished work on the vehicle.

- Remove the separate enclosure and unpack it. Check the separate enclosure for completeness.
- Check the vehicle for transport damage.



Warning

Danger of accidents A repaired handlebar poses a safety risk.

If the handlebar is bent or straightened, the material becomes fatigued. The handlebar may break as a result.

- Change the handlebar if the handlebar is damaged or bent.

- Position the handlebar.



Info

Make sure the cables and wiring are positioned correctly.

- Position the handlebar clamp. Mount and tighten the screws evenly.

Guideline

| | | |
|------------------------|----|--|
| Screw, handlebar clamp | M8 | 19 Nm (14 lbf ft) Loctite®243™ |
|------------------------|----|--|

- ✓ The lettering on the handlebar is in the middle of the handlebar clamp.

- Position all controls in their exact positions on the handlebar. Tighten all screws.

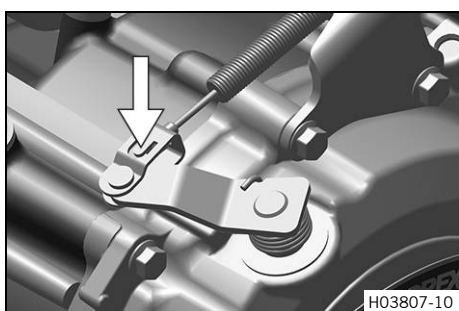
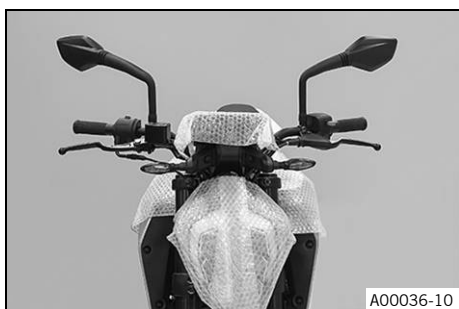

- Make sure that the clutch cable is attached to the clutch release lever and secured.
- Check the clutch lever play. (📖 p. 6)
- Check the play in the throttle cable. (📖 p. 7)
- Mount and tighten the rear mirror on both sides.

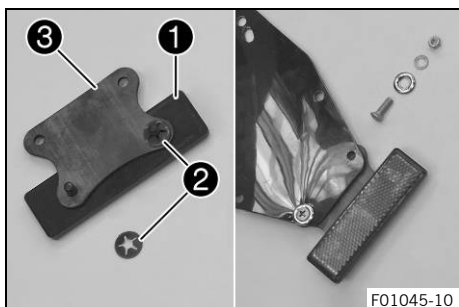

- Mount rear reflector ① with spring washers ② on holding plate ③.
- Mount the retaining plate on the license plate holder.
- Mount the license plate holder.
- Carefully loosen and remove the tension belt over the link fork.



Info

An assistant prevents the motorcycle from falling over.



E01183-01

- Carefully loosen and remove the tension belts around the lower triple clamp.
- ✓ The vehicle is released at the front.
- Together with an assistant, take the vehicle off the pallet.
- Remove the passenger seat. (📖 p. 7)
- Take tool set out of the separate enclosure and fasten onto the bottom of the passenger seat using the rubber straps provided in the tool set.
- Remove the front rider's seat. (📖 p. 8)
- Remove spare key and **KEYCODECARD** from under the seat and keep in a safe place for the handover.



Warning

Risk of injury Battery acid and battery gases cause serious chemical burns.

- Keep 12 V batteries out of the reach of children.
- Wear suitable protective clothing and safety glasses.
- Avoid contact with battery acid and battery gases.
- Keep sparks or open flames away from the 12 V battery.
- Only charge 12 V batteries in well-ventilated rooms.
- Rinse the affected area immediately with plenty of water in the event of contact with the skin.
- Rinse eyes with water for at least 15 minutes and consult a doctor immediately if battery acid and battery gases get into the eyes.

- Fill the 12 V battery.



Info

Read the notes in the 12 V battery accessory pack.

- Charge the 12-V battery. (📖 p. 9)
- Install the 12-V battery. (📖 p. 11)
- Remove the remaining film, padding, the corrugated cardboard, and the other packaging material.
- Refuel. (📖 p. 13)
- Check the headlight setting. (📖 p. 14)
- Prepare the vehicle according to the specifications in the **KTM Dealer.net** for handover to the customer.



Info

Transport mode must be deactivated to be able to start the motorcycle.

3.1 Checking the clutch lever play

Note

Clutch damage If there is no free travel by the clutch lever, the clutch will begin to slip.

- Check the free travel of the clutch lever each time before using the motorcycle.
- Adjust the free travel of the clutch lever when necessary in accordance with the specification.

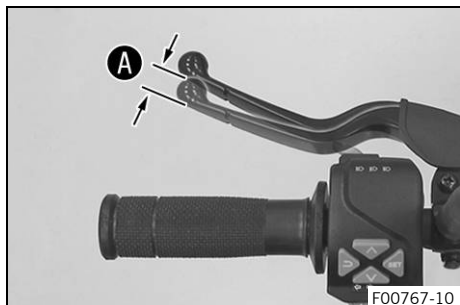

- Check the clutch lever for smooth operation.
- Move the handlebar to the straight-ahead position.
- Pull the clutch lever until resistance is perceptible, and determine the play in the clutch lever **A**.

| | |
|----------------------------|-------------------------------|
| Clutch lever play A | 1 ... 3 mm (0.04 ... 0.12 in) |
|----------------------------|-------------------------------|

- » If the clutch lever play does not meet the specified value:
 - Adjust play in the clutch lever. (📖 p. 6)
- Move the handlebar to and fro over the entire steering range.

| |
|--|
| The clutch lever play must not change. |
|--|

- » If the clutch lever play changes:
 - Check the routing of the clutch cable.

3.2 Adjusting play in the clutch lever

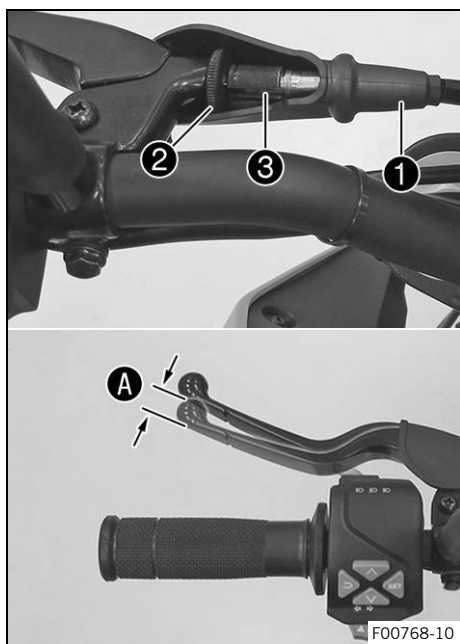

- Move the handlebar to the straight-ahead position.
- Push back sleeve **1**.
- Loosen lock nut **2**.
- Adjust the play in the clutch level **A** by turning adjusting screw **3**.

Guideline

| | |
|----------------------------|-------------------------------|
| Clutch lever play A | 1 ... 3 mm (0.04 ... 0.12 in) |
|----------------------------|-------------------------------|

- Tighten lock nut **2**.
- Position bellows **1**.

3.3 Checking the play in the throttle cable

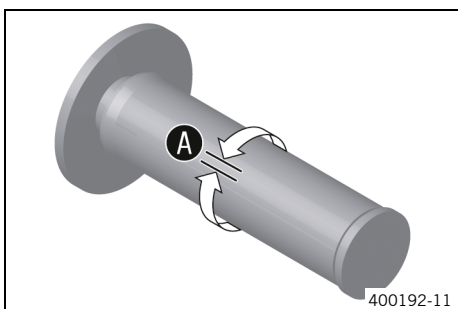

- Check the throttle grip for smooth operation.
- Move the handlebar to the straight-ahead position. Turn the throttle grip back and forth slightly and determine the play in throttle cable **A**.

| | |
|------------------------------|------------------------------|
| Throttle cable play A | 3 ... 5 mm (0.12 ... 0.2 in) |
|------------------------------|------------------------------|

- » If the throttle cable play does not meet the specified value:
 - Adjust the play in the throttle cable. (📖 p. 7)

⚠ Danger
Danger of poisoning Exhaust gases are toxic and inhaling them may result in unconsciousness and death.

- Always make sure there is sufficient ventilation when running the engine.
- Use effective exhaust extraction when starting or running the engine in an enclosed space.

- Start the engine and let it run at idle speed. Move the handlebar to and fro over the entire steering range.

| |
|---------------------------------|
| The idle speed must not change. |
|---------------------------------|

- » If the idle speed changes:
 - Check the throttle cable routing.

3.4 Adjusting the play in the throttle cable

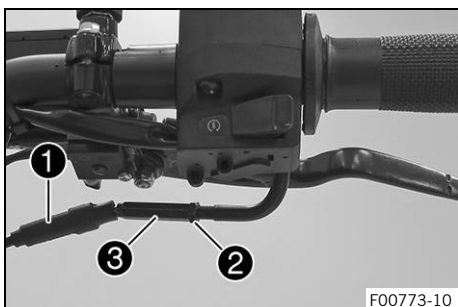

- Move the handlebar to the straight-ahead position.
- Push back sleeve **1**.
- Loosen lock nut **2**.
- Adjust the play in the throttle cable by turning barrel adjuster **3**.

Guideline

| | |
|------------------------|------------------------------|
| Play in throttle cable | 3 ... 5 mm (0.12 ... 0.2 in) |
|------------------------|------------------------------|

- Tighten lock nut **2**.
- Slide on sleeve **1**.

3.5 Removing the passenger seat

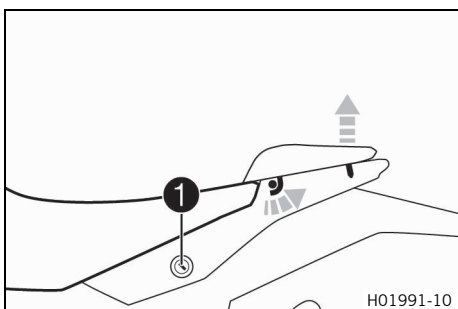

- Insert the ignition key in seat lock **1** and turn it clockwise.
- Raise the rear of the seat, push it towards the rear, and lift it off.
- Remove the ignition key from the seat lock.

3.6 Mounting the passenger seat

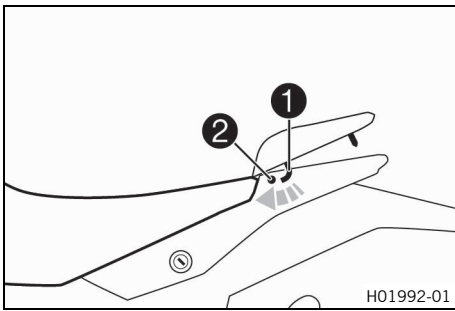

- Attach hooks ① on the passenger seat to seat mountings ② on the subframe, and lower it at the rear while pushing forward.
- Press the passenger seat downward until it clicks into place.



Warning

Danger of accidents The seat can come loose from the anchoring if it is not mounted correctly.

- After assembly, check whether the seat is correctly locked and cannot be pulled up.

- Finally, check that the passenger seat is correctly mounted.

3.7 Removing the front rider's seat

Preparatory work

- Remove the passenger seat. (📖 p. 7)

Main work

- Raise the rear of the front rider's seat, pull it towards the rear, and remove it upwards.

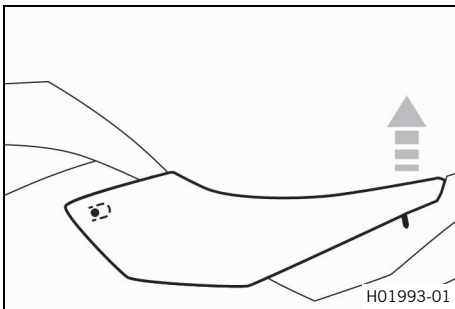

3.8 Mounting the front rider's seat

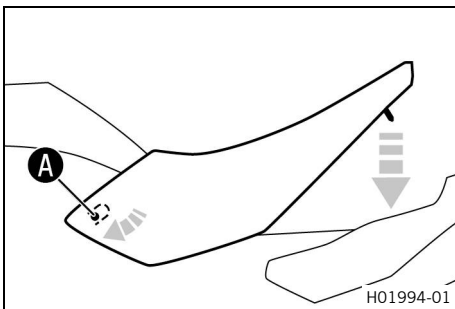

Main work

- Attach the front rider's seat in area A and lower at the rear.
- Finally, check that the front rider's seat is correctly mounted.

Finishing work

- Mount the passenger seat. (📖 p. 8)

3.9 Disconnecting the negative cable of the 12-V battery

Preparatory work

- Remove the passenger seat. (🔧 p. 7)
- Remove the front rider's seat. (🔧 p. 8)



Main work

- Disconnect negative cable ① of the 12-V battery.

3.10 Connecting the negative cable of the 12-V battery



Main work

- Connect negative cable ① of the 12-V battery.

Finishing work

- Mount the front rider's seat. (🔧 p. 8)
- Mount the passenger seat. (🔧 p. 8)
- Set time and date. (🔧 p. 11)

3.11 Charging the 12-V battery



Warning

Risk of injury Battery acid and battery gases cause serious chemical burns.

- Keep 12 V batteries out of the reach of children.
- Wear suitable protective clothing and safety glasses.
- Avoid contact with battery acid and battery gases.
- Keep sparks or open flames away from the 12 V battery.
- Only charge 12 V batteries in well-ventilated rooms.
- Rinse the affected area immediately with plenty of water in the event of contact with the skin.
- Rinse eyes with water for at least 15 minutes and consult a doctor immediately if battery acid and battery gases get into the eyes.

Note

Danger of damage An incorrectly selected charging mode will damage the 12-V battery.

- Always select a charging mode that is compatible with the type of battery.



Note

Environmental hazard 12 V batteries contain environmentally hazardous materials.

- Do not dispose of 12 V batteries as household waste.
- Dispose of 12 V batteries at a collection point for used batteries.



Note

Environmental hazard Hazardous substances cause environmental damage.

- Dispose of oils, grease, filters, fuel, cleaning agents, brake fluid, etc., correctly and in compliance with the applicable regulations.



Info

Even when there is no load on the 12-V battery, it discharges steadily each day. The charging level and the method of charging are very important for the service life of the 12-V battery. Rapid recharging with a high charging current shortens the service life of the battery. If the charging current, charging voltage, or charging time is exceeded, electrolyte escapes through the safety valves. This reduces the capacity of the 12-V battery. If the 12-V battery is discharged by repeated starting, charge the 12-V battery immediately. If the 12-V battery is left in a discharged state for an extended period, it will become deeply discharged and sulfating occurs, thus destroying the battery. The 12-V battery is maintenance-free. The acid level does not have to be checked.

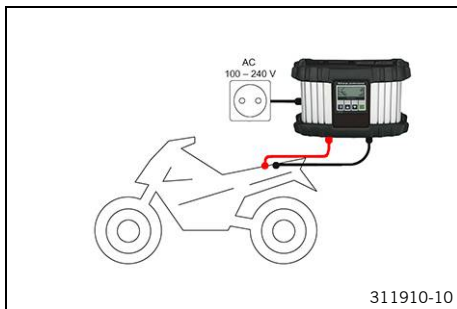

Preparatory work

- Remove the passenger seat. (📖 p. 7)
- Remove the front rider's seat. (📖 p. 8)
- Disconnect the negative cable of the 12-V battery. (📖 p. 9)

Main work

- Connect a battery charger to the 12-V battery. Adjust the battery charger.

EU battery charger **XCharge-professional** (00029095050)

Alternative 1

US battery charger **XCharge-professional** (00029095051)

Alternative 2

UK battery charger **XCharge-professional** (00029095052)



Info

Follow the instructions of the charger and the manual.

- Disconnect the battery charger after charging the 12-V battery.
- Guideline

| | |
|---|----------|
| The charging current, charging voltage, and charging time must not be exceeded. | |
| Recharge the 12-V battery regularly when the motorcycle is not being used | 6 months |

Finishing work

- Connect the negative cable of the 12-V battery. (📖 p. 9)
- Mount the front rider's seat. (📖 p. 8)
- Mount the passenger seat. (📖 p. 8)
- Set time and date. (📖 p. 11)

3.12 Installing the 12-V battery

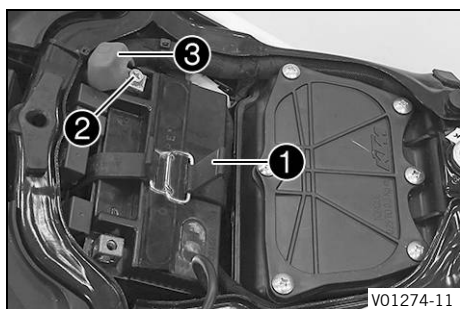

Main work

- Position the 12-V battery in the battery compartment.

12-V battery (ETZ-9-BS)

- Attach rubber strap ①.
- Position positive cable ② and mount and tighten the screw.
- Position positive terminal cover ③.

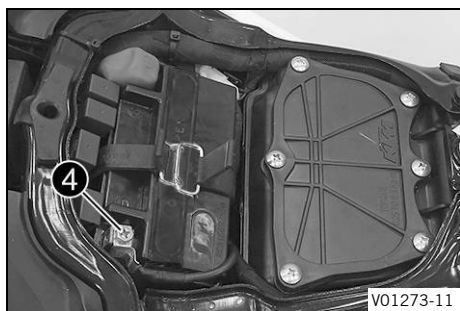

- Position negative cable ④ and mount and tighten the screw.

Finishing work

- Mount the front rider's seat. (📖 p. 8)
- Mount the passenger seat. (📖 p. 8)
- Set time and date. (📖 p. 11)



3.13 Setting the time and date

Condition

The motorcycle is stationary.

- Press the **SET** button when the menu is closed.
- Press **UP** or **DOWN** button until **Settings** appears. Press the **SET** button to open the menu.
- Press the **UP** or **DOWN** button until **Time/Date** is highlighted. Press the **SET** button to open the menu.

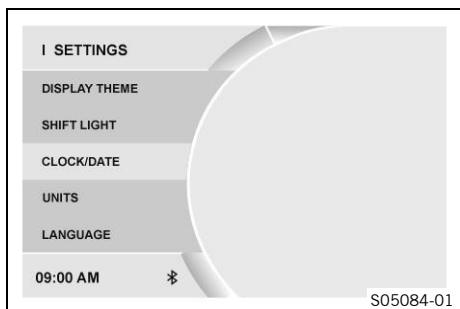

Setting the clock

- Press **UP** or **DOWN** button until the time is marked.
- Press the **SET** button.
 - ✓ The hour flashes and is underlined.
- Press **UP** or **DOWN** button until the current hour is set.
- Press the **SET** button.
 - ✓ The minutes flash and are underlined.
- Press **UP** or **DOWN** button until the current minute is set.
- Press the **SET** button.
 - ✓ The time is stored.

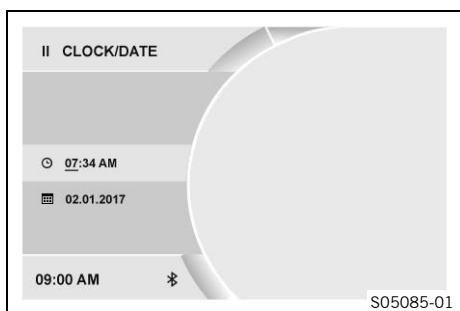

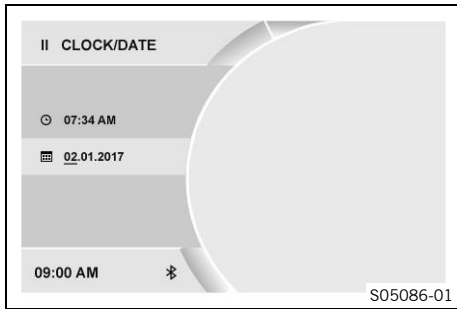

Setting the date

- Press **UP** or **DOWN** button until the date is marked.
- Press the **SET** button.
 - ✓ The day flashes and is underlined.
- Press **UP** or **DOWN** button until the current day is set.
- Press the **SET** button.
 - ✓ The month flashes and is underlined.
- Press **UP** or **DOWN** button until the current month is set.
- Press the **SET** button.
 - ✓ The year flashes and is underlined.
- Press **UP** or **DOWN** button until the current year is set.
- Press the **SET** button.
 - ✓ The date is stored.

3.14 Opening fuel tank filler cap



Danger

Fire hazard Fuel is highly flammable.

The fuel in the fuel tank expands when warm and can escape if overfilled.

- Do not fuel the vehicle in the vicinity of open flames or lit cigarettes.
- Switch off the engine for refueling.
- Make sure that no fuel is spilled; particularly not on hot parts of the vehicle.
- If any fuel is spilled, wipe it off immediately.
- Observe the specifications for refueling.



Warning

Danger of poisoning Fuel is harmful to health.

- Avoid skin, eye and clothing contact with fuel.
- Immediately consult a doctor if you swallow fuel.
- Do not inhale fuel vapors.
- Rinse the affected area immediately with plenty of water in the event of contact with the skin.
- Rinse the eyes thoroughly with water, and consult a doctor in case of fuel contact with the eyes.
- Change your clothing if fuel spills on them.
- Keep fuels correctly in a suitable canister, and out of the reach of children.



Note

Environmental hazard Improper handling of fuel is a danger to the environment.

- Do not allow fuel to enter the groundwater, the soil, or the sewage system.

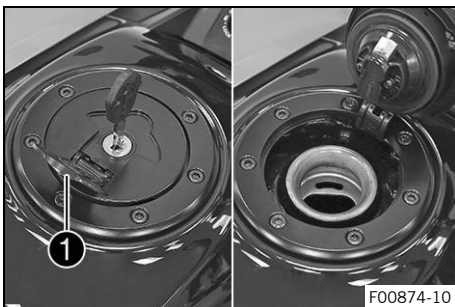

- Lift cover **1** of the fuel tank filler cap and insert the ignition key into the lock.

Note

Danger of damage The ignition key may break if overloaded.

Damaged ignition keys must be replaced.

- Push down on the fuel tank filler cap to take pressure off the ignition key.
- Turn the ignition key 90° clockwise.
- Lift the fuel tank filler cap.

- Remove the ignition key.



3.15 Closing the fuel tank filler cap

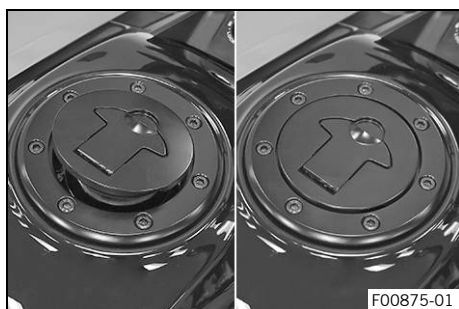

Warning

Fire hazard Fuel is highly flammable and a health hazard.

- Check that the fuel tank filler cap is locked correctly after closing.
- Change your clothing if fuel spills on them.
- Rinse the affected area immediately with plenty of water in the event of contact with the skin.

- Close the fuel tank filler cap.
- Push down the fuel tank filler cap until the lock engages.



3.16 Refueling



Danger

Fire hazard Fuel is highly flammable.

The fuel in the fuel tank expands when warm and can escape if overfilled.

- Do not fuel the vehicle in the vicinity of open flames or lit cigarettes.
- Switch off the engine for refueling.
- Make sure that no fuel is spilled; particularly not on hot parts of the vehicle.
- If any fuel is spilled, wipe it off immediately.
- Observe the specifications for refueling.



Warning

Danger of poisoning Fuel is harmful to health.

- Avoid skin, eye and clothing contact with fuel.
- Immediately consult a doctor if you swallow fuel.
- Do not inhale fuel vapors.
- Rinse the affected area immediately with plenty of water in the event of contact with the skin.
- Rinse the eyes thoroughly with water, and consult a doctor in case of fuel contact with the eyes.
- Change your clothing if fuel spills on them.

Note

Material damage Inadequate fuel quality causes the fuel filter to quickly become clogged.

In some countries and regions, the available fuel quality and cleanliness may not be sufficient. This will result in problems with the fuel system.

- Refuel only with clean fuel that meets the specified standards.



Note

Environmental hazard Improper handling of fuel is a danger to the environment.

- Do not allow fuel to enter the groundwater, the soil, or the sewage system.

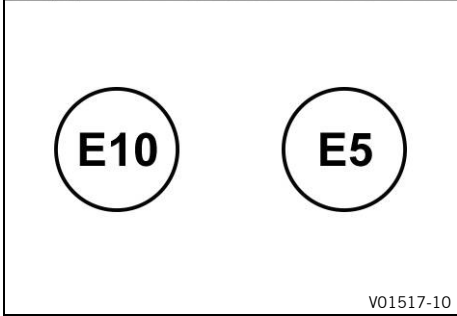
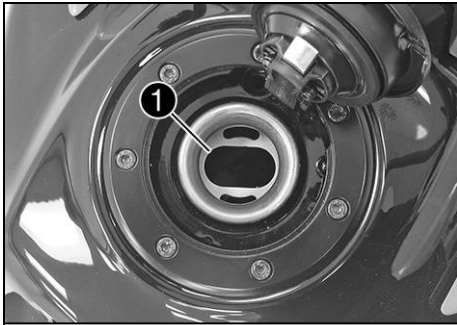

V01517-10

- Switch off the engine.
- Open the fuel tank filler cap. (📖 p. 12)
- Fill the fuel tank with fuel up to the lower edge **1** of the fuel filler.

| | | |
|-----------------------------------|-------------------------|---|
| Total fuel tank capacity, approx. | 13.4 l (3.54 US gal) | Super unleaded (ROZ 95) (📖 p. 19) |
|-----------------------------------|-------------------------|---|

- Close the fuel tank filler cap. (📖 p. 13)

3.17 Checking the headlight setting

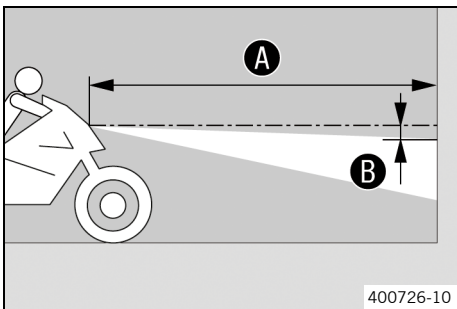

400726-10

- Park the vehicle on a horizontal surface in front of a light-colored wall and make a mark at the height of the center of the low beam headlight.
- Make another mark at a distance **B** under the first marking.
Guideline

| | |
|-------------------|-------------|
| Distance B | 5 cm (2 in) |
|-------------------|-------------|

- Position the vehicle vertical to the wall at distance **A** from the wall and switch on the low beam.
Guideline

| | |
|-------------------|-------------|
| Distance A | 5 m (16 ft) |
|-------------------|-------------|

- The rider now mounts the motorcycle with luggage and passenger if applicable.
- Check the headlight setting.

The light-dark boundary must be exactly on the lower marking when the motorcycle is ready to be operated with the rider mounted along with any luggage and a passenger if applicable.

- » If the boundary between light and dark does not meet specifications:
 - Adjust the headlight range. (📖 p. 15)

3.18 Adjusting the headlight range

Preparatory work

- Check the headlight setting. (📖 p. 14)

Main work

- Turn adjusting screw ❶ to adjust the headlight range.

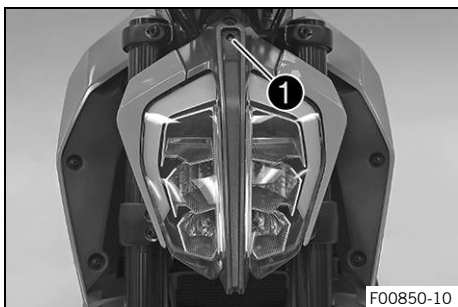

F00850-10

i Info

Turn clockwise to increase the headlight range; turn counterclockwise to reduce the headlight range. If you have a payload, you may have to correct the headlight range.

Screw ❶ also secures the headlight. Ensure the screw is always screwed in far enough.

- Set the headlight to marking ❷.

Guideline

The light-dark boundary must lie exactly on lower marking ❷ when the motorcycle is ready to operate with the rider mounted along with any luggage and a passenger if applicable.

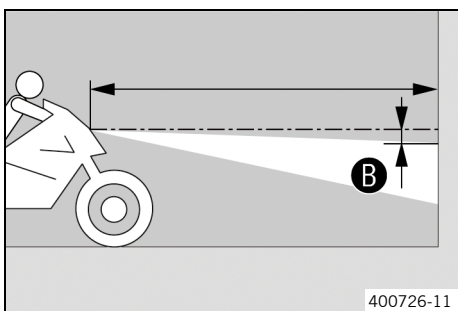

400726-11

4 TECHNICAL SPECIFICATIONS

4.1 chassis tightening torques

| | | | |
|---|-----------------|--------------------|--------------|
| Screw, chain guard | EJOT PT® K60x30 | 7 Nm (5.2 lbf ft) | |
| Remaining screws, chassis | M4 | 4 Nm (3 lbf ft) | |
| Remaining nuts, chassis | M5 | 5 Nm (3.7 lbf ft) | |
| Remaining screws, chassis | M5 | 5 Nm (3.7 lbf ft) | |
| Screw, chain guard | M5 | 7 Nm (5.2 lbf ft) | Loctite®243™ |
| Screw, chain sliding guard | M5 | 7 Nm (5.2 lbf ft) | |
| Screw, compensating tank cap lock, rear brake | M5 | 9 Nm (6.6 lbf ft) | |
| Screw, fuel tank cover | M5 | 4 Nm (3 lbf ft) | |
| Screw, outer clutch cable guide | M5 | 5 Nm (3.7 lbf ft) | |
| Screw, tail light | M5 | 5 Nm (3.7 lbf ft) | |
| Brake cylinder screw on the rear brake system | M6 | 7 Nm (5.2 lbf ft) | Loctite®243™ |
| Nut, foot brake lever adjustment | M6 | 9 Nm (6.6 lbf ft) | |
| Remaining nuts, chassis | M6 | 9 Nm (6.6 lbf ft) | |
| Remaining screws, chassis | M6 | 9 Nm (6.6 lbf ft) | |
| Screw, ABS hose clamp | M6 | 7 Nm (5.2 lbf ft) | |
| Screw, ABS module | M6 | 7 Nm (5.2 lbf ft) | |
| Screw, ABS module retaining bracket on frame | M6 | 7 Nm (5.2 lbf ft) | |
| Screw, air filter box | M6 | 6 Nm (4.4 lbf ft) | |
| Screw, brake fluid reservoir for rear brake | M6 | 7 Nm (5.2 lbf ft) | |
| Screw, brake hose clamp | M6 | 7 Nm (5.2 lbf ft) | |
| Screw, combination instrument | M6 | 7 Nm (5.2 lbf ft) | |
| Screw, compensating tank | M6 | 5 Nm (3.7 lbf ft) | |
| Screw, damper block | M6 | 7 Nm (5.2 lbf ft) | |
| Screw, engine sprocket cover | M6 | 8 Nm (5.9 lbf ft) | |
| Screw, front fender | M6 | 7 Nm (5.2 lbf ft) | |
| Screw, front seat fixing | M6 | 6 Nm (4.4 lbf ft) | |
| Screw, front spoiler | M6x13 | 9 Nm (6.6 lbf ft) | |
| Screw, front spoiler rear | M6x9 | 6 Nm (4.4 lbf ft) | |
| Screw, fuel pump | M6 | 9 Nm (6.6 lbf ft) | |
| Screw, headlight | M6 | 7 Nm (5.2 lbf ft) | |
| Screw, ignition coil | M6 | 8 Nm (5.9 lbf ft) | |
| Screw, ignition lock (tamper-proof screw) | M6 | 13 Nm (9.6 lbf ft) | |
| Screw, license plate holder | M6 | 10 Nm (7.4 lbf ft) | Loctite®243™ |
| Screw, lower rear panel | M6 | 7 Nm (5.2 lbf ft) | |
| Screw, magnetic holder on side stand | M6 | 5 Nm (3.7 lbf ft) | Loctite®243™ |
| Screw, main silencer | M6 | 12 Nm (8.9 lbf ft) | |
| Screw, main silencer retaining bracket | M6 | 9 Nm (6.6 lbf ft) | |

| | | | |
|---|------|---------------------|----------------------|
| Screw, protective plate | M6 | 7 Nm (5.2 lbf ft) | |
| Screw, radiator holder | M6 | 10 Nm (7.4 lbf ft) | |
| Screw, radiator shield | M6 | 7 Nm (5.2 lbf ft) | |
| Screw, rear splash protector | M6 | 9 Nm (6.6 lbf ft) | |
| Screw, shift lever linkage | M6 | 11 Nm (8.1 lbf ft) | Loctite®243™ |
| Screw, side stand sensor | M6 | 9 Nm (6.6 lbf ft) | Loctite®243™ |
| Screw, side stand sensor cable holder | M6 | 9 Nm (6.6 lbf ft) | Loctite®243™ |
| Screw, tilt sensor | M6 | 6 Nm (4.4 lbf ft) | |
| Screw, wheel speed sensor holder | M6 | 8 Nm (5.9 lbf ft) | |
| Screw, wheel speed sensor of rear wheel | M6 | 8 Nm (5.9 lbf ft) | Loctite®243™ |
| Nut, rear sprocket | M8 | 27 Nm (19.9 lbf ft) | Loctite®243™ |
| Remaining nuts, chassis | M8 | 30 Nm (22.1 lbf ft) | |
| Remaining screws, chassis | M8 | 25 Nm (18.4 lbf ft) | |
| Screw, bottom triple clamp | M8 | 15 Nm (11.1 lbf ft) | |
| Screw, engine bearer | M8 | 22 Nm (16.2 lbf ft) | |
| Screw, foot brake lever | M8 | 16 Nm (11.8 lbf ft) | Loctite®243™ |
| Screw, fork stub | M8 | 15 Nm (11.1 lbf ft) | |
| Screw, front brake disc | M8 | 30 Nm (22.1 lbf ft) | Loctite®243™ |
| Screw, front seat fixing | M8 | 20 Nm (14.8 lbf ft) | |
| Screw, fuel tank | M8 | 16 Nm (11.8 lbf ft) | |
| Screw, grab handle | M8 | 22 Nm (16.2 lbf ft) | |
| Screw, handlebar clamp | M8 | 19 Nm (14 lbf ft) | Loctite®243™ |
| Screw, horn | M8 | 12 Nm (8.9 lbf ft) | |
| Screw, lower rear panel | M8 | 15 Nm (11.1 lbf ft) | Loctite®243™ |
| Screw, main silencer | M8 | 23 Nm (17 lbf ft) | |
| Screw, passenger footrest unit | M8 | 22 Nm (16.2 lbf ft) | Loctite®243™ |
| Screw, rear brake disc | M8 | 21 Nm (15.5 lbf ft) | Loctite®243™ |
| Screw, rear seat fixing | M8 | 18 Nm (13.3 lbf ft) | |
| Screw, seat support plate | M8 | 18 Nm (13.3 lbf ft) | |
| Screw, subframe | M8 | 25 Nm (18.4 lbf ft) | Loctite® 620™ |
| Screw, top triple clamp | M8 | 15 Nm (11.1 lbf ft) | |
| Screw, wheel spindle, front | M8 | 20 Nm (14.8 lbf ft) | |
| Screw, front brake caliper | M8x1 | 29 Nm (21.4 lbf ft) | Loctite®243™ |
| Banjo bolt, brake line | M10 | 24 Nm (17.7 lbf ft) | |

4 TECHNICAL SPECIFICATIONS

| | | |
|---|------------|---|
| Fitting side stand | M10 | 35 Nm (25.8 lbf ft) Loctite®243™ |
| Nut, left rear mirror | M10 | 27 Nm (19.9 lbf ft) |
| Remaining nuts, chassis | M10 | 50 Nm (36.9 lbf ft) |
| Remaining screws, chassis | M10 | 45 Nm (33.2 lbf ft) |
| Screw, engine bearer | M10 | 49 Nm (36.1 lbf ft) Loctite®243™ |
| Fitting, handlebar support | M10x1.25 | 21 Nm (15.5 lbf ft) |
| Fitting, shock absorber, bottom | M10x1.25 | 50 Nm (36.9 lbf ft) Loctite®243™ |
| Nut, right rear mirror | M10LHx1.25 | 27 Nm (19.9 lbf ft) |
| Nut, side stand bracket | M10x1.25 | 35 Nm (25.8 lbf ft) |
| Screw, combination instrument bracket | M10x1.25 | 21 Nm (15.5 lbf ft) |
| Screw, front footrest bracket | M10x1.25 | 47 Nm (34.7 lbf ft) |
| Screw, front footrest bracket / engine bearer | M10x1.25 | 50 Nm (36.9 lbf ft) |
| Screw, top shock absorber | M10x1.25 | 50 Nm (36.9 lbf ft) Loctite®243™ |
| Stud, rear sprocket | M10x1.25 | 50 Nm (36.9 lbf ft) |
| Nut, rear wheel spindle | M14x1.5 | 98 Nm (72.3 lbf ft) |
| Nut, swingarm pivot | M14x1.5 | 98 Nm (72.3 lbf ft) |
| Screw, steering head, top | M16x1.5 | 47 Nm (34.7 lbf ft) Loctite®243™ |
| Lambda sensor | M18x1.5 | 19 Nm (14 lbf ft) |
| Adjusting ring, link fork bearing | M22x1 | Tighten and ensure that there is no play |
| Nut, steering head | M30x1 | 1st stage 45 Nm (33.2 lbf ft) 2nd stage (loosen, counterclockwise) 2 turns 3rd stage 5 Nm (3.7 lbf ft) |

Super unleaded (ROZ 95)

Standard/classification

- DIN EN 228 (ROZ 95)

Guideline

- Only use super unleaded fuel that matches or is equivalent to the specified standard.
- Fuel with an ethanol content of up to 10% (E10 fuel) is safe to use.



Info

Do **not** use fuel containing methanol (e.g., M15, M85, M100) or more than 10% ethanol (e.g., E15, E25, E85, E100).



3214868en

03.05.2023

