

350 SX-F
350 XC-F
350 XC-F FACTORY EDITION

ART. NO. 3214878EN



Perform the work described in these setup instructions before the vehicle is delivered to the customer.

Read the setup instructions in their entirety before beginning work.

These setup instructions were written to correspond to the latest state of this model series. We reserve the right to make modifications in the interest of technical advancement without at the same time updating these setup instructions.

We shall not provide a description of general workshop methods. Likewise, safety rules that apply in a workshop are not specified here. It is assumed that the work will be performed by a fully trained mechanic.

All specifications contained herein are non-binding. KTM Sportmotorcycle GmbH specifically reserves the right to modify or delete technical specifications, prices, colors, forms, materials, services, designs, equipment, etc., without prior notice and without specifying reasons, to adapt these to local conditions, as well as to stop production of a particular model without prior notice. KTM Sportmotorcycle accepts no liability for delivery options, deviations from figures and descriptions, as well as misprints and other errors. The models portrayed partly contain special equipment that does not belong to the regular scope of supply.

© 2023 KTM Sportmotorcycle GmbH, Mattighofen Austria

All rights reserved

Reproduction, even in part, as well as copying of all kinds, is permitted only with the express written permission of the copyright owner.



ISO 9001(12 100 6061)

KTM applies quality assurance processes that lead to the highest possible product quality as defined in the ISO 9001 international quality management standard.

Issued by: TÜV Management Service

REG.NO. 12 100 6061

KTM Sportmotorcycle GmbH
Stallhofnerstraße 3
5230 Mattighofen, Austria

This document is valid for the following models:

350 SX-F EU (F8201X5)

350 SX-F US (F8275X5)

350 SX-F AR (F8242X5)

350 XC-F US (F8275X0)

350 XC-F FACTORY EDITION US (F8275X3)



1 MEANS OF REPRESENTATION

1.1 Symbols used

The meaning of specific symbols is described below.



Indicates an expected reaction (e.g. of a work step or a function).



Indicates an unexpected reaction (e.g. of a work step or a function).



Indicates a page reference (more information is provided on the specified page).



Indicates information with more details or tips.



Indicates the result of a testing step.



Indicates a voltage measurement.



Indicates a current measurement.



Indicates a resistance measurement.



Indicates the end of an activity including potential rework.

1.2 Formats used

The typographical formats used in this document are explained below.

Proprietary name

Indicates a proprietary name.

Name®

Indicates a protected name.

Brand™

Indicates a brand available on the open market.

Underlined terms

Refer to technical details of the vehicle or indicate technical terms, which are explained in the glossary.

2.1 Transport mode

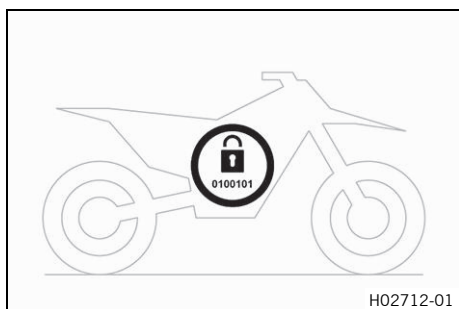

This vehicle was blocked for transport in the software. To operate the vehicle, the vehicle electronics must be enabled. This process is conducted during initial setup in KTM Dealer.net. Enabling ensures that the initial setup in KTM Dealer.net is documented.

Enabling can be performed either temporarily, e.g. for a test ride, or permanently for vehicle handover.

i Info

Make sure that the vehicle is permanently enabled before handing it over to the customer.

2.2 Diagnostics connector

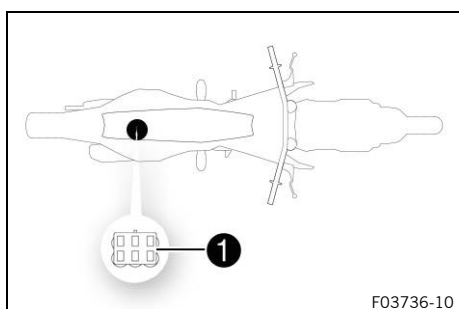

Diagnostics connector **1** is located under the seat.

i Info

As soon as the diagnostics tool is connected, the service hour counter starts running. Before longer diagnostic sessions, unplug the service hour counter behind the start number plate.

2.3 Unpacking and setting up the vehicle

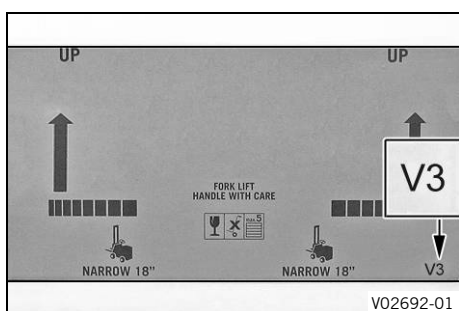

Package 3

- Remove the box and the plastic packaging.

i Info

To avoid damaging the motorcycle during the setup, leave the protective film on the vehicle until you have finished.

- Remove the separate enclosure and unpack it. Check that the scope of supply is complete on the basis of the enclosed packing list.

i Info

The procedure for missing components is described in the Customer Service Manual.

- Carefully loosen and remove the tension belts around the fork legs.
- Remove the attachment on the rear wheel.

i Info

An assistant prevents the motorcycle from falling over.

- Have a lift stand available.

| |
|--------------------------|
| Lift stand (78129955100) |
|--------------------------|

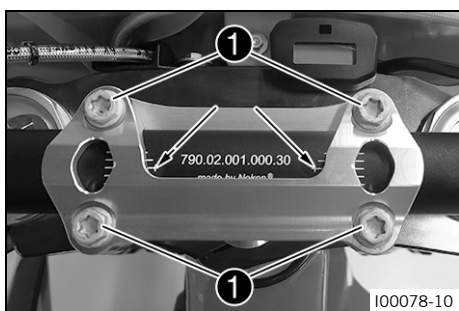
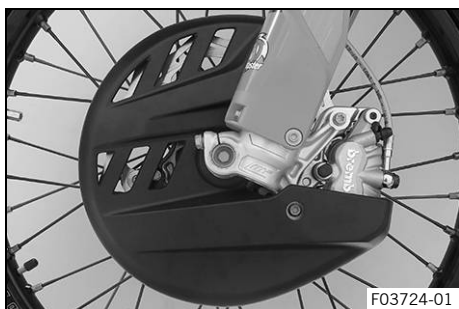
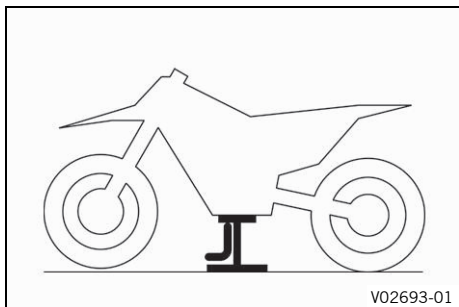

- Together with an assistant, take the vehicle off the pallet.
- Position the vehicle on a lift stand.
- Check the vehicle for transport damage.

i Info
The procedure in the event of transport damage is described in the Customer Service Manual.

(FACTORY EDITION)

- Remove the front wheel. (📖 p. 10)
- Mount the brake disc guard.

i Info
Read the accompanying **KTM PowerParts** instructions.
Align the brake disc guard so that the distances are the same size.

- Install the front wheel. (📖 p. 12)

- Remove cable ties on the side cover and remove film from the handlebar.

⚠ Warning
Danger of accidents A repaired handlebar poses a safety risk.
If the handlebar is bent or straightened, the material becomes fatigued. The handlebar may break as a result.

- Change the handlebar if the handlebar is damaged or bent.

- Position the handlebar.

i Info
Make sure the cables and wiring are positioned correctly.
Do not kink the cables or lines.

- Position the handlebar clamp.
- Mount screws 1, but do not tighten yet.
- First bolt the handlebar clamp with screws 1 onto the longer, higher side of the handlebar supports so that both parts touch.
- Tighten screws 1 evenly.

Guideline

| | | |
|------------------------|----|---------------------|
| Screw, handlebar clamp | M8 | 20 Nm (14.8 lbf ft) |
|------------------------|----|---------------------|

i Info
The markings on the handlebar should be at the center of the handlebar clamps.

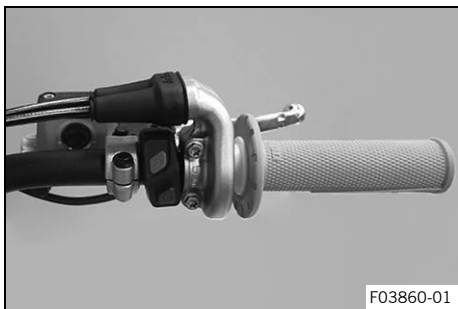

- Position the controls on the right half of the handlebar.

Guideline

| | | |
|--------------------------|-------------------------------|-------------------|
| Screw, throttle grip | M6 | 5 Nm (3.7 lbf ft) |
| Screw, start/stop button | EJOT PT® K50x18 T20 | 2 Nm (1.5 lbf ft) |

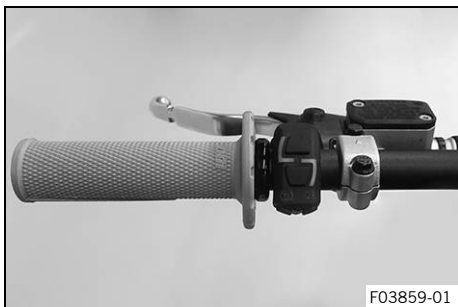

- Position the controls on the left handlebar half.

Guideline

| | | |
|---------------------------|-------------------------------|--|
| Screw, fixed grip | M4 | 5 Nm (3.7 lbf ft) Loctite®243™ |
| Screw, combination switch | EJOT PT® K50x18 T20 | 2 Nm (1.5 lbf ft) |

(All XC-F models)

- Preassemble the hand guards on the left and right.

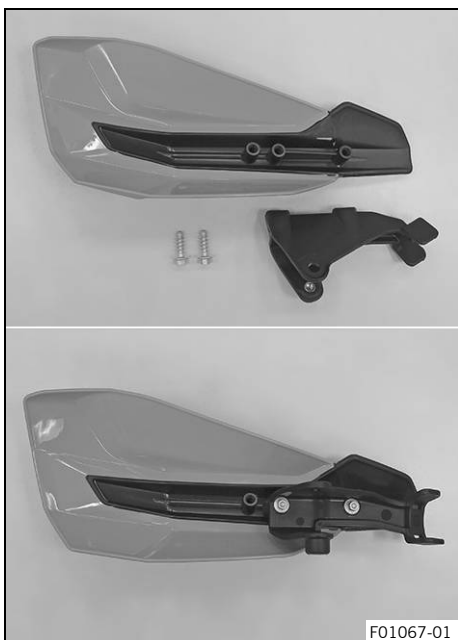



- Mount the left hand guard.
- Mount the right hand guard.

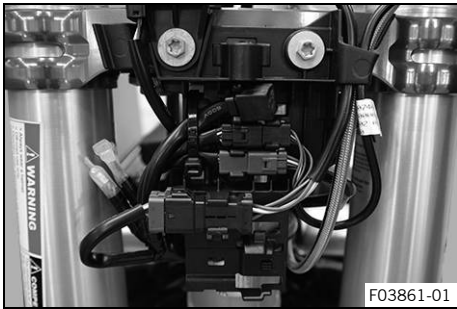

- Remove the start number plate. (📖 p. 14)
- Join all plug-in connectors.
- Route the cables without tension and secure with the cable ties.
- Install the start number plate. (📖 p. 14)



- Mount the handlebar cushion.

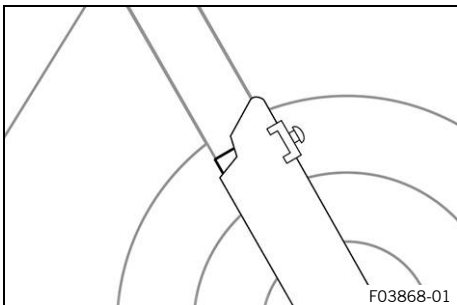

(FACTORY EDITION)

- Mount the Factory-Start.



Info

Read the accompanying **KTM PowerParts** instructions.

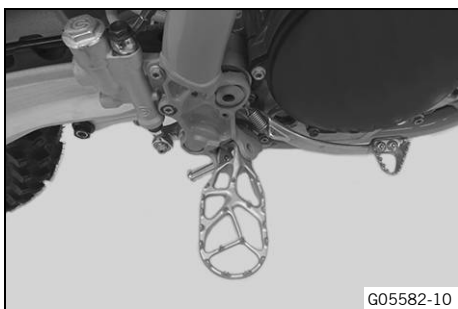

- Position the new footrest and pin.

i Info
Only insert the pin to the extent that the spring can still be mounted.

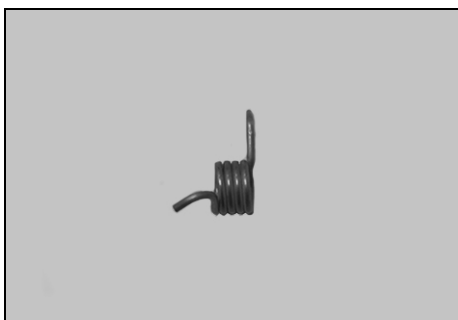

- Position spring as shown.
- ✓ Spring engages in area **A** and **B**.

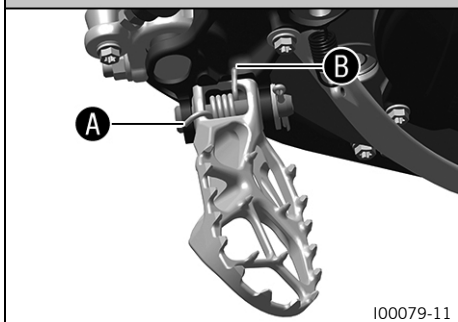

- Apply pressure to the spring with your thumb.
- Mount pin **2**.

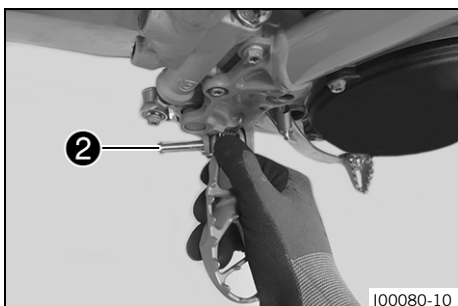

- Mount the washer and splint **3**.
- Repeat these steps on the opposite side.
- Install the frame protector. (📖 p. 15)

(All XC-F models)

- Install the engine guard. (📖 p. 16)

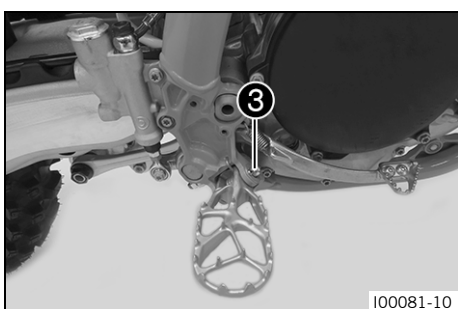

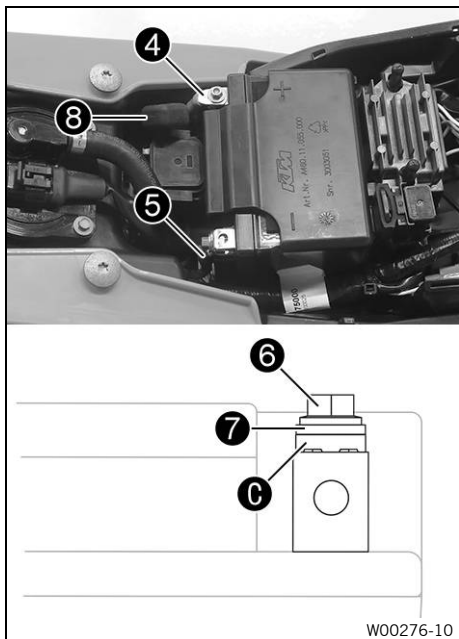

- Remove the seat. (📖 p. 14)
- Connect positive cable ④ to the 12-V battery.

Guideline

| | | |
|-------------------------|----|-------------------------|
| Screw, battery terminal | M5 | 2.5 Nm (1.84 lbf ft) |
|-------------------------|----|-------------------------|

- Connect negative cable ⑤ to the 12 V battery.

Guideline

| | | |
|-------------------------|----|-------------------------|
| Screw, battery terminal | M5 | 2.5 Nm (1.84 lbf ft) |
|-------------------------|----|-------------------------|

Contact disks ③ must be mounted under screws ⑥ and cable sockets ⑦ with the claws toward the battery terminal.

- Slide positive terminal cover ⑧ over the positive terminal.
- Charge the 12-V battery. (📖 p. 16)

Guideline

The 12-V battery must be fully charged before it is handed over to the customer.

i Info
The first charging process may take longer with a new 12-V battery.

- Unpack and mount the **KTM PowerParts** included in the delivery (optional).

i Info
Read the accompanying **KTM PowerParts** fitting instructions.

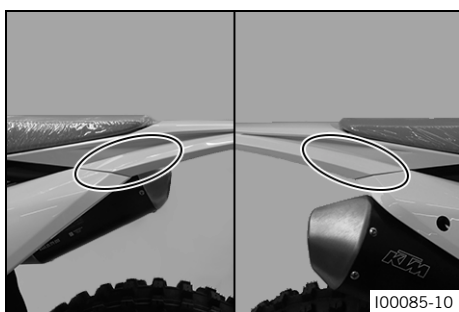

- Stick displacement sticker on the left and right of the side cover.
- Attach the stickers included in the scope of supply (optional).
- Refuel. (📖 p. 20)
- Position all controls in their exact positions on the handlebar. Tighten all screws.
- Remove the remaining film, padding, the corrugated cardboard, and the other packaging material.
- Prepare the vehicle according to the specifications in **KTM Dealer.net** for handover to the customer.

i Info
Transport mode must be deactivated to be able to start the motorcycle.

3.1 Removing the motorcycle from the lift stand

Note

Material damage The vehicle may be damaged by incorrect procedure when parking.

Significant damage may be caused if the vehicle rolls away or falls over.

The components for parking the vehicle are designed only for the weight of the vehicle.

- Park the vehicle on a firm and level surface.
- Ensure that nobody sits on the vehicle when the vehicle is parked on a stand.

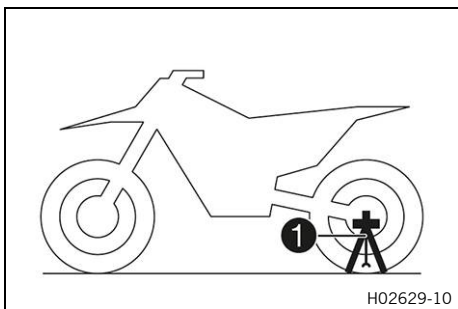

(All SX-F models)

- Remove the motorcycle from the lift stand.
- Remove the lift stand.
- To park the motorcycle, insert plug-in stand ① into the left side of the wheel spindle.

Plug-in stand (A46029094000)

i Info
The plug-in stand is included.
Remove the plug-in stand before riding.

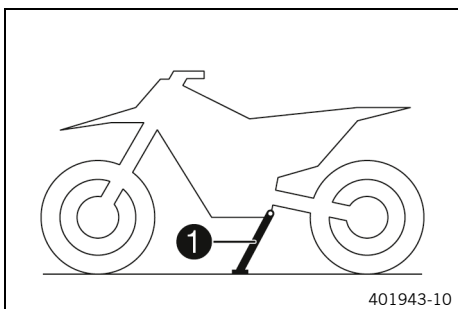

(All XC-F models)

- Remove the motorcycle from the lift stand.
- Remove the lift stand.
- To park the motorcycle, press side stand ① to the ground with your foot and lean the motorcycle on it.

i Info
When you are riding, the side stand must be folded up and secured with the rubber strap.

3.2 Raising the motorcycle with a lift stand

Note

Material damage The vehicle may be damaged by incorrect procedure when parking.

Significant damage may be caused if the vehicle rolls away or falls over.

The components for parking the vehicle are designed only for the weight of the vehicle.

- Park the vehicle on a firm and level surface.
- Ensure that nobody sits on the vehicle when the vehicle is parked on a stand.

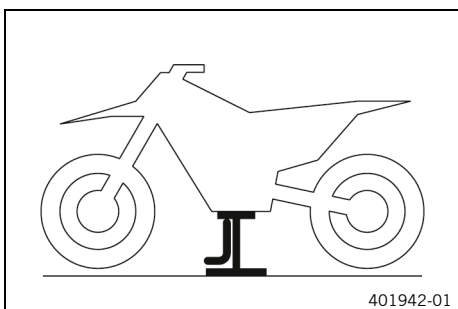

(All SX-F models)

- Remove the plug-in stand and lift up the motorcycle by the frame underneath the engine.

Lift stand (78129955100)

✓ Neither wheel is in contact with the ground.

(All XC-F models)

- Fold in the side stand and raise the motorcycle at the frame underneath the engine.

Lift stand (78129955100)

- ✓ Neither wheel is in contact with the ground.
- Secure the motorcycle against falling over.

3.3 Removing the front wheel

Preparatory work

- Raise the motorcycle with a lift stand. (📖 p. 9)

Main work

(All standard models)

- Manually press the brake caliper toward the brake disc to push back the brake pistons.



Info

Make sure that you do not press the brake caliper against the spokes when pushing back the brake pistons.

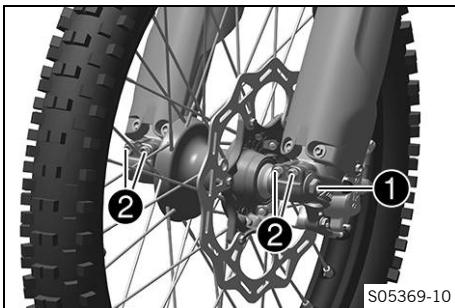

- Loosen screw ① by several rotations.
- Loosen screws ②.
- Press on screw ① to push the wheel spindle out of the axle clamp.
- Remove screw ①.

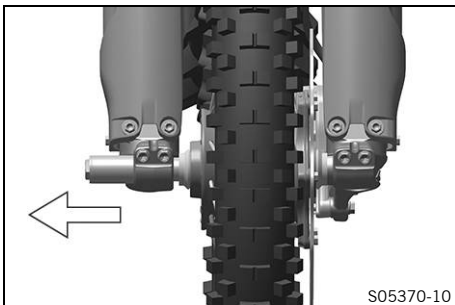

Warning

Danger of accidents Damaged brake discs reduce the braking effect.

- Always lay the wheel down in such a way that the brake disc is not damaged.

- Hold front wheel and remove wheel spindle. Take the front wheel out of the fork.



Info

Do not actuate the hand brake lever when the front wheel is removed.

- Remove spacers ③.

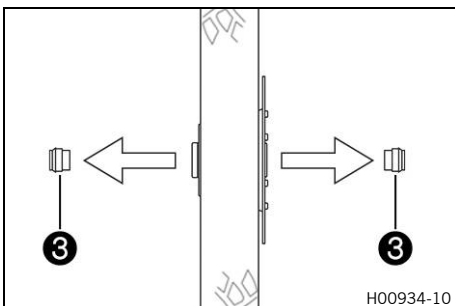

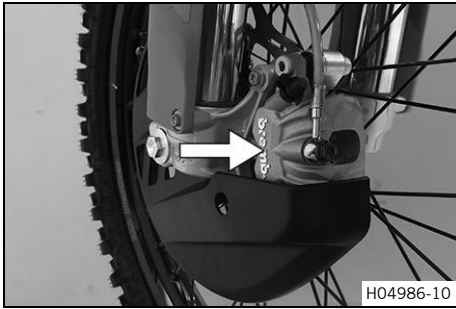

(FACTORY EDITION)

- Manually press the brake caliper toward the brake disc to push back the brake pistons.

i Info
Make sure that you do not press the brake caliper against the spokes when pushing back the brake pistons.

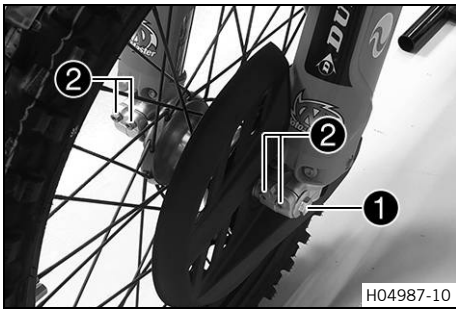

- Loosen screw 1 by several rotations.
- Loosen screws 2.
- Press on screw 1 to push the wheel spindle out of the axle clamp.
- Remove screw 1.

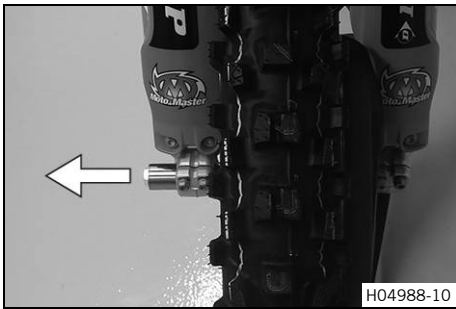

! Warning
Danger of accidents Damaged brake discs reduce the braking effect.
- Always lay the wheel down in such a way that the brake disc is not damaged.

- Hold front wheel and remove wheel spindle. Take the front wheel out of the fork.

i Info
Do not actuate the hand brake lever when the front wheel is removed.

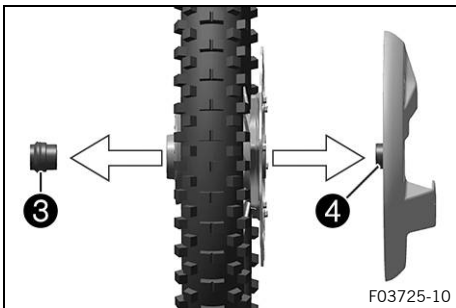

- Remove spacers 3 and brake disc guard 4.

3.4 Installing the front wheel



Warning

Danger of accidents Oil or grease on the brake discs reduces the braking effect.

- Always keep the brake discs free of oil and grease.
- Clean the brake discs with brake cleaner when necessary.

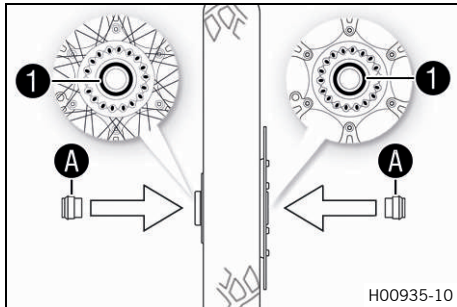

(All standard models)

- Check the wheel bearing for damage and wear.
 - » If the wheel bearing is damaged or worn:
 - Change front wheel bearing.
- Clean and grease shaft seal rings **1** and contact surfaces **A** of the spacers.

Long-life grease (📖 p. 25)

- Insert the spacers.
- Clean and lightly grease the wheel spindle.

Long-life grease (📖 p. 25)

- Position the front wheel and insert the wheel spindle.
 - ✓ The brake linings are correctly positioned.

- Mount and tighten screw **2**.

Guideline

| | | |
|----------------------------|---------|------------------------|
| Screw, front wheel spindle | M20x1.5 | 35 Nm (25.8 lbf ft) |
|----------------------------|---------|------------------------|

- Operate the hand brake lever several times until the brake linings are seated correctly against the brake disc.
- Remove the motorcycle from the lift stand. (📖 p. 9)
- Operate the front brake and compress the fork a few times firmly.

- ✓ The fork legs straighten.

- Tighten screws **3**.

Guideline

| | | |
|------------------|----|------------------------|
| Screw, fork stub | M8 | 15 Nm (11.1 lbf ft) |
|------------------|----|------------------------|

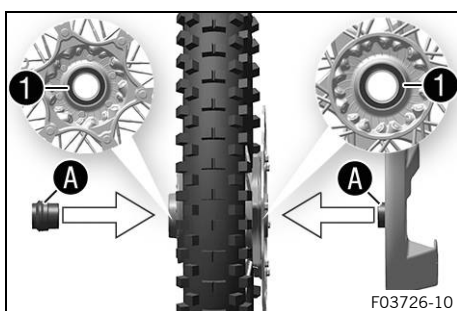
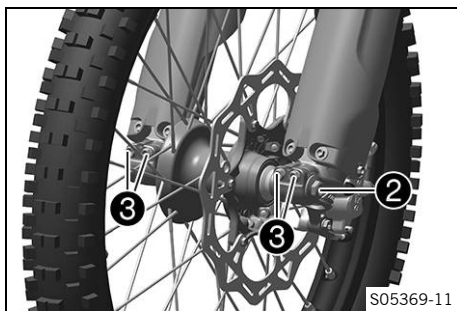

(FACTORY EDITION)

- Check the wheel bearing for damage and wear.
 - » If the wheel bearing is damaged or worn:
 - Change front wheel bearing.
- Clean and grease shaft seal rings **1** and contact surfaces **A** of the spacers.

Long-life grease (📖 p. 25)

- Insert the spacers.
- Clean and lightly grease the wheel spindle.

Long-life grease (📖 p. 25)

- Position the front wheel and insert the wheel spindle.
 - ✓ The brake linings are correctly positioned.

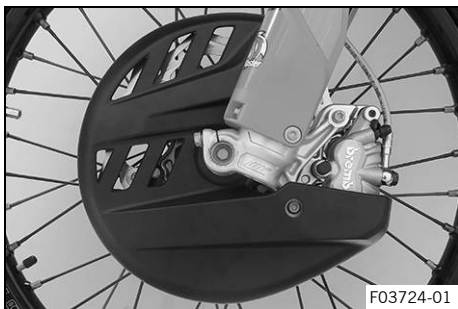

- Position the brake disc guard.

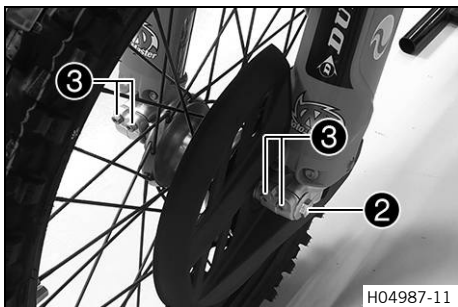

- Mount and tighten screw 2.

Guideline

| | | |
|----------------------------|---------|------------------------|
| Screw, front wheel spindle | M20x1.5 | 35 Nm (25.8 lbf ft) |
|----------------------------|---------|------------------------|

- Operate the hand brake lever several times until the brake linings are seated correctly against the brake disc.
- Remove the motorcycle from the lift stand. (📖 p. 9)
- Operate the front brake and compress the fork a few times firmly.

✓ The fork legs straighten.

- Tighten screws 3.

Guideline

| | | |
|------------------|----|------------------------|
| Screw, fork stub | M8 | 15 Nm (11.1 lbf ft) |
|------------------|----|------------------------|

3.5 Installing the front fender

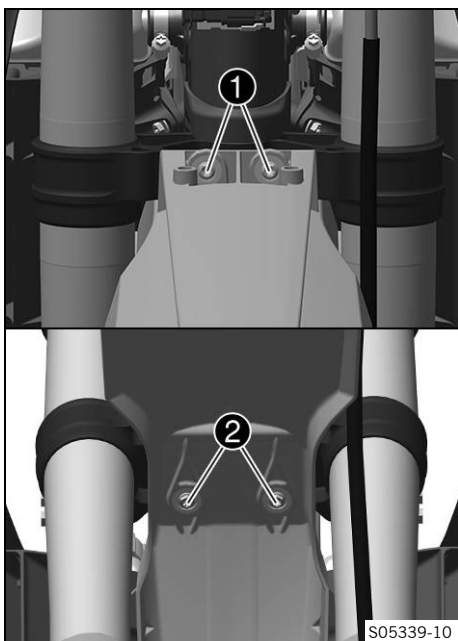

Main work

- Position the front fender. Mount and tighten screws 1 and 2.

Guideline

| | | |
|---------------|----|--------------------|
| Screw, fender | M6 | 12 Nm (8.9 lbf ft) |
|---------------|----|--------------------|

Finishing work

- Install the start number plate. (📖 p. 14)

3.6 Removing the start number plate

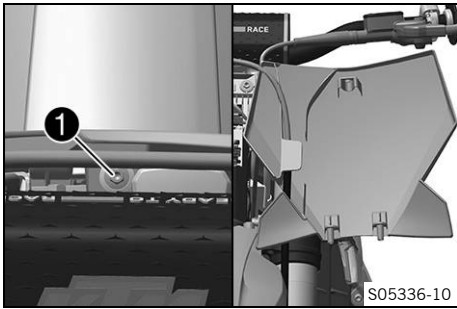

- Remove screw ❶.
- Unhook the start number plate from the brake line and remove it.

3.7 Installing the start number plate

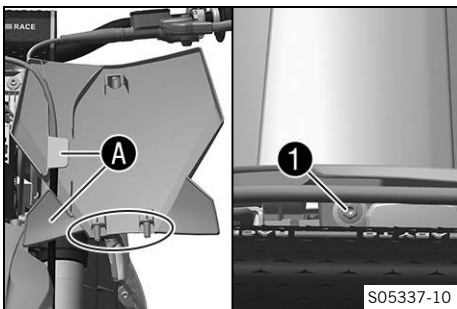

- Position the brake line in holders A on the start number plate.
- Position the start number plate. Mount and tighten screw ❶.
- ✓ The holding lugs engage in the fender.

3.8 Removing the seat



Caution

Danger of burns The voltage regulator gets very hot when the vehicle is operated.

- Allow the voltage regulator to cool down before performing any work.

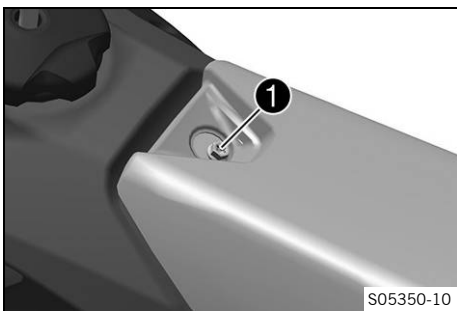

- Remove screw ❶.

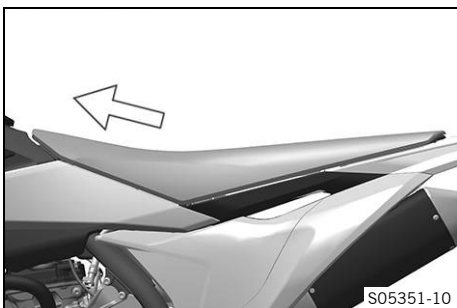

- Pull seat toward the fuel tank and lift it off.

3.9 Mounting the seat

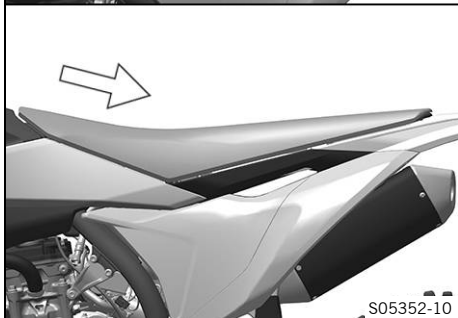
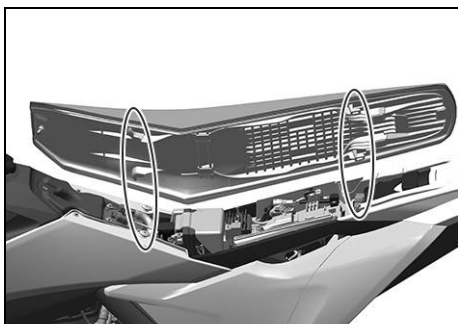

- Attach the seat to the collar bushings at the front and simultaneously push it back.
- ✓ The holding lugs engage in the recesses at the back.
- Make sure the seat is latched in place correctly.

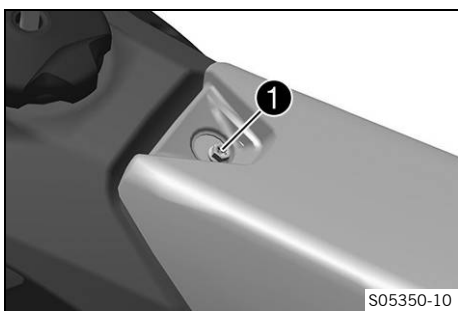

- Mount and tighten screw ①.

Guideline

| | | |
|--------------------|----|-------------------|
| Screw, seat fixing | M6 | 8 Nm (5.9 lbf ft) |
|--------------------|----|-------------------|

3.10 Installing the frame protector

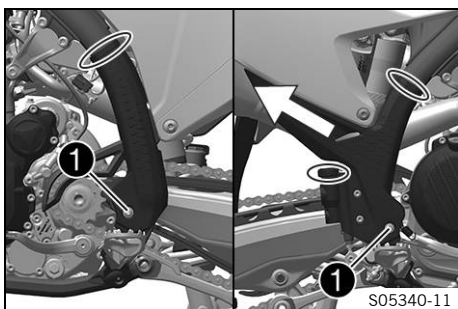

- Position the left frame protector.
- Insert the right frame protector from below and push it to the rear.
- Mount screws ① with the bushings and tighten.

Guideline

| | | |
|------------------------|----|-------------------|
| Screw, frame protector | M5 | 3 Nm (2.2 lbf ft) |
|------------------------|----|-------------------|

- Secure the frame protector with cable ties.

3.11 Installing the engine guard (All XC-F models)

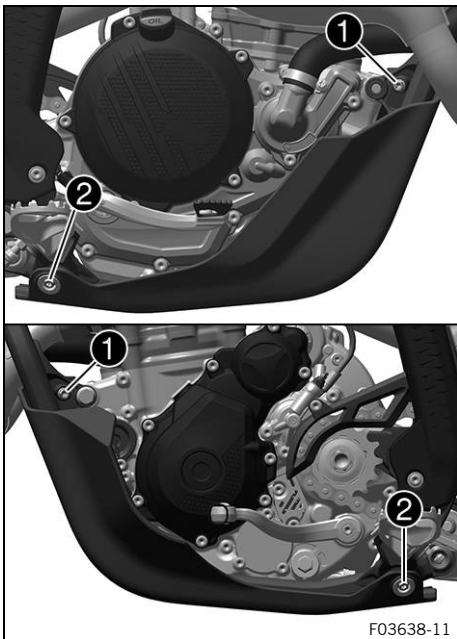

- Position the engine guard on the frame.
- Mount screws ①, but do not tighten yet.

Guideline

| | | |
|---------------------------|----|--------------------|
| Remaining screws, chassis | M6 | 10 Nm (7.4 lbf ft) |
|---------------------------|----|--------------------|

- Mount screws ② with bushings, but do not tighten yet.

Guideline

| | | |
|---------------------------|----|--------------------|
| Remaining screws, chassis | M6 | 10 Nm (7.4 lbf ft) |
|---------------------------|----|--------------------|

✓ The engine guard is directed evenly toward the front.

- Tighten all the screws of the engine guard.

Guideline

| | | |
|---------------------------|----|--------------------|
| Remaining screws, chassis | M6 | 10 Nm (7.4 lbf ft) |
|---------------------------|----|--------------------|

3.12 Charging the 12-V battery



Warning

Risk of injury 12 V batteries contain harmful substances.

- Keep 12 V batteries out of the reach of children.
- Keep sparks and open flames away from 12 V batteries.
- Only charge 12 V batteries in well-ventilated rooms.
- Maintain a minimum clearance from inflammable materials when charging 12 V batteries.
Minimum clearance 1 m (3 ft)
- Do not charge deeply discharged 12 V batteries if the charge is already below the minimum voltage.
Minimum voltage before the start of the charge 9 V
- Dispose of 12 V batteries correctly if they have less than the minimum voltage.



Note

Environmental hazard 12 V batteries contain environmentally hazardous materials.

- Do not dispose of 12 V batteries as household waste.
- Dispose of 12 V batteries at a collection point for used batteries.



Note

Environmental hazard Hazardous substances cause environmental damage.

- Dispose of oils, grease, filters, fuel, cleaning agents, brake fluid, etc., correctly and in compliance with the applicable regulations.

i Info

Even when there is no load on the 12-V battery, it discharges steadily each day. The charging level and the method of charging are very important for the service life of the 12-V battery. Rapid recharging with a high charging current shortens the service life of the battery. If the charging current, charging voltage, or charging time is exceeded, the 12-V battery will be destroyed. If the 12-V battery is depleted by repeated starting, the 12-V battery must be charged immediately. If the 12-V battery is left in a discharged state for an extended period, it will become deeply discharged and suffer a loss of capacity, destroying the battery. The 12-V battery is maintenance-free.

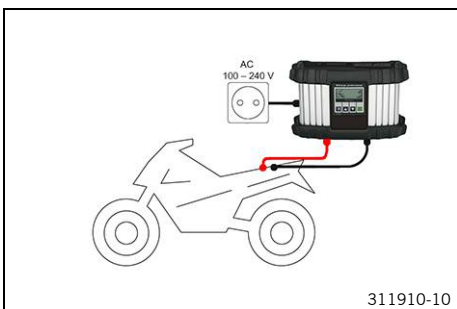

Preparatory work

- Remove the seat. (📖 p. 14)
- Disconnect the negative cable of the 12-V battery. (📖 p. 17)

Main work

- Connect a battery charger to the 12-V battery. Adjust the battery charger.

EU battery charger **XCharge-professional** (00029095050)

Alternative 1

US battery charger **XCharge-professional** (00029095051)

Alternative 2

UK battery charger **XCharge-professional** (00029095052)

i Info

Follow the instructions of the charger and the manual.

- Disconnect the battery charger after charging the 12-V battery.

Guideline

| | |
|---|----------|
| The charging current, charging voltage, and charging time must not be exceeded. | |
| Recharge the 12-V battery regularly when the motorcycle is not being used | 3 months |

Finishing work

- Connect the negative cable of the 12-V battery. (📖 p. 18)
- Mount the seat. (📖 p. 15)



3.13 Disconnecting the negative cable of the 12-V battery

Preparatory work

- Remove the seat. (📖 p. 14)

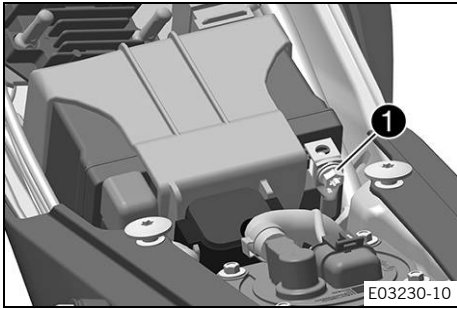

Main work

- Disconnect negative cable ① of the 12-V battery.

3.14 Connecting the negative cable of the 12-V battery

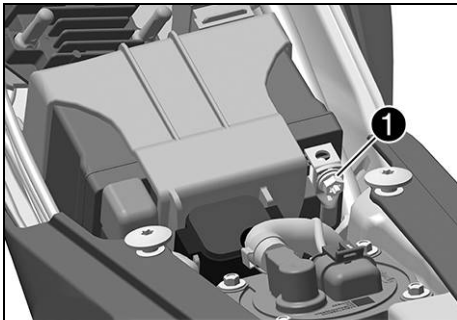

Main work

- Connect negative cable ① of the 12-V battery.

Guideline

| | | |
|-------------------------|----|-------------------------|
| Screw, battery terminal | M5 | 2.5 Nm (1.84 lbf ft) |
|-------------------------|----|-------------------------|

Contact disk **A** must be mounted under screw **2** and cable lug **3** with the claws toward the battery terminal.

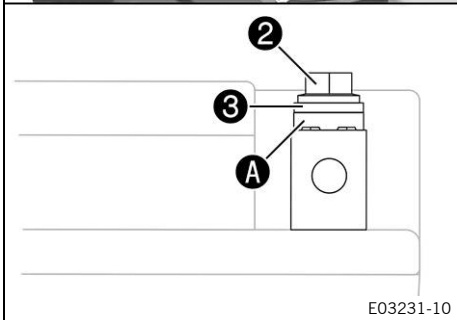

Finishing work

- Mount the seat. (📖 p. 15)

3.15 Opening the fuel tank filler cap



Danger

Fire hazard Fuel is highly flammable.

The fuel in the fuel tank expands when warm and can escape if overfilled.

- Do not fuel the vehicle in the vicinity of open flames or lit cigarettes.
- Switch off the engine for refueling.
- Make sure that no fuel is spilled; particularly not on hot parts of the vehicle.
- If any fuel is spilled, wipe it off immediately.
- Observe the specifications for refueling.



Warning

Danger of poisoning Fuel is harmful to health.

- Avoid skin, eye and clothing contact with fuel.
- Immediately consult a doctor if you swallow fuel.
- Do not inhale fuel vapors.
- Rinse the affected area immediately with plenty of water in the event of contact with the skin.
- Rinse the eyes thoroughly with water, and consult a doctor in case of fuel contact with the eyes.
- Change your clothing if fuel spills on them.
- Keep fuels correctly in a suitable canister, and out of the reach of children.



Note

Environmental hazard Improper handling of fuel is a danger to the environment.

- Do not allow fuel to enter the groundwater, the soil, or the sewage system.

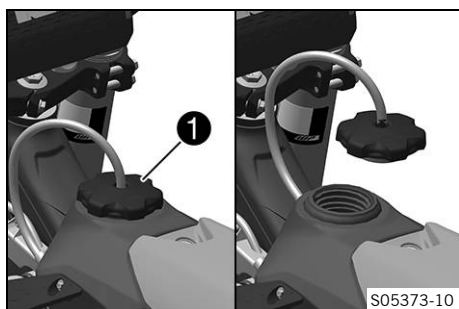

(All SX-F models)

- Turn fuel tank filler cap ① counterclockwise and lift it off.

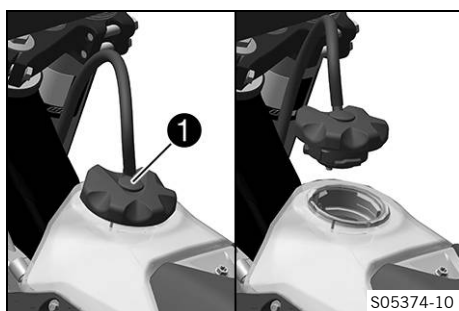

(All XC-F models)

- Press release button ①, turn the fuel tank filler cap counterclockwise, and lift it off.

3.16 Closing the fuel tank filler cap

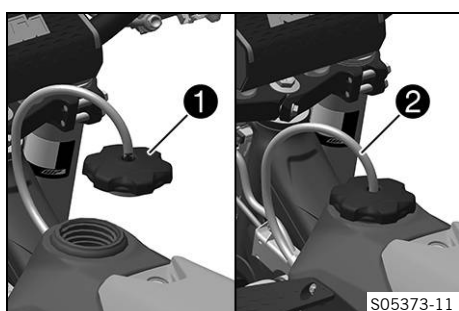

(All SX-F models)

- Mount fuel tank filler cap ① and turn it clockwise until the fuel tank is tightly closed.



Info

Route fuel tank breather hose ② without kinks.

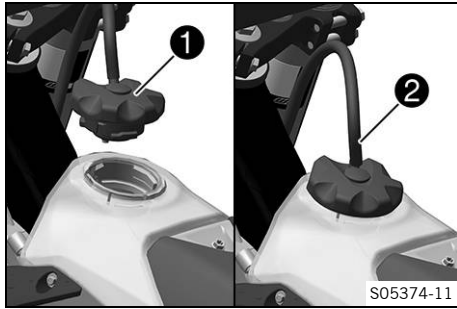

(All XC-F models)

- Mount filler cap ① and turn it clockwise until the release button engages.



Info

Route fuel tank breather hose ② without kinks.

3.17 Refueling



Danger

Fire hazard Fuel is highly flammable.

The fuel in the fuel tank expands when warm and can escape if overfilled.

- Do not fuel the vehicle in the vicinity of open flames or lit cigarettes.
- Switch off the engine for refueling.
- Make sure that no fuel is spilled; particularly not on hot parts of the vehicle.
- If any fuel is spilled, wipe it off immediately.
- Observe the specifications for refueling.



Warning

Danger of poisoning Fuel is harmful to health.

- Avoid skin, eye and clothing contact with fuel.
- Immediately consult a doctor if you swallow fuel.
- Do not inhale fuel vapors.
- Rinse the affected area immediately with plenty of water in the event of contact with the skin.
- Rinse the eyes thoroughly with water, and consult a doctor in case of fuel contact with the eyes.
- Change your clothing if fuel spills on them.

Note

Material damage Inadequate fuel quality causes the fuel filter to quickly become clogged.

In some countries and regions, the available fuel quality and cleanliness may not be sufficient. This will result in problems with the fuel system.

- Refuel only with clean fuel that meets the specified standards.



Note

Environmental hazard Improper handling of fuel is a danger to the environment.

- Do not allow fuel to enter the groundwater, the soil, or the sewage system.

- Switch off the engine.
- Open the fuel tank filler cap. (📖 p. 18)

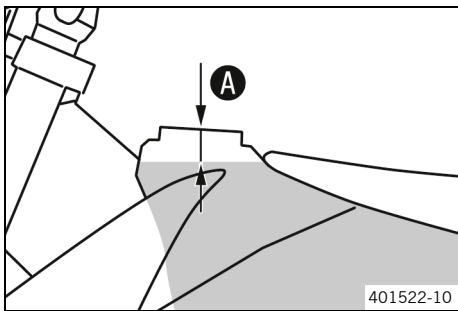

- Fill the fuel tank with fuel up to a maximum of level **A**.

Guideline

| | |
|--------------------|-----------------|
| Dimension A | 35 mm (1.38 in) |
|--------------------|-----------------|

| | | |
|---|------------------------|--|
| Total fuel tank capacity, approx. (All SX-F models) | | |
| Total fuel tank capacity, approx. | 7.2 l (1.9 US gal) | Super unleaded (ROZ 95) (📖 p. 24) (All SX-F models) |
| Total fuel tank capacity, approx. (All XC-F models) | | |
| Total fuel tank capacity, approx. | 8.5 l (2.25 US gal) | Super unleaded (ROZ 95) (📖 p. 24) (XC-F US) |

- Close the fuel tank filler cap. (📖 p. 19)



4 TECHNICAL SPECIFICATIONS

4.1 chassis tightening torques

| | | |
|---|----------------------------|--|
| Screw, air filter box cover | EJOT PT® K60x20-Z | 3 Nm (2.2 lbf ft) |
| Screw, air filter box, on subframe | EJOT PT® K60x20AL | 5 Nm (3.7 lbf ft) |
| Screw, combination switch | EJOT PT® K50x18 T20 | 2 Nm (1.5 lbf ft) |
| Screw, fuel pump on fuel tank | EJOT PT® K60x30-Z | 2.5 Nm (1.84 lbf ft) |
| Screw, intake air temperature sensor | EJOT PT® K50x18 T20 | 0.7 Nm (0.52 lbf ft) |
| Screw, radiator hoses clip | | 2.4 Nm (1.77 lbf ft) |
| Screw, seat fixing | EJOT EJOFORM PT® K60x23/18 | 2.5 Nm (1.84 lbf ft) |
| Screw, start/stop button | EJOT PT® K50x18 T20 | 2 Nm (1.5 lbf ft) |
| Screw, fixed grip | M4 | 5 Nm (3.7 lbf ft) Loctite®243™ |
| Screw, throttle valve body hose clamp | M4 | 5 Nm (3.7 lbf ft) |
| Spoke nipple, front wheel | M4.5 | 6 Nm (4.4 lbf ft) |
| Spoke nipple, rear wheel | M4.5 | 6 Nm (4.4 lbf ft) |
| Remaining nuts, chassis | M5 | 5 Nm (3.7 lbf ft) |
| Remaining screws, chassis | M5 | 5 Nm (3.7 lbf ft) |
| Screw, battery terminal | M5 | 2.5 Nm (1.84 lbf ft) |
| Screw, frame protector | M5 | 3 Nm (2.2 lbf ft) |
| Screw, shock absorber adjusting ring | M5 | 5 Nm (3.7 lbf ft) |
| Screw, throttle valve body cover | M5 | 2.6 Nm (1.92 lbf ft) |
| Screws on main silencer | M5 | 7 Nm (5.2 lbf ft) |
| Nut, starter cable on starter motor | M6 | 4 Nm (3 lbf ft) |
| Nut, throttle cable on throttle valve body | M6 | 3 Nm (2.2 lbf ft) |
| Remaining nuts, chassis | M6 | 10 Nm (7.4 lbf ft) |
| Remaining screws, chassis | M6 | 10 Nm (7.4 lbf ft) |
| Screw, battery support bracket | M6 | 6 Nm (4.4 lbf ft) |
| Screw, brake line guide on link fork | M6 | 4.5 Nm (3.32 lbf ft) |
| Screw, chain guide on link fork at the front | M6x45 | 10 Nm (7.4 lbf ft) |
| Screw, chain guide on link fork at the rear | M6x16 | 10 Nm (7.4 lbf ft) |
| Screw, chain sliding guard on link fork | M6 | 6 Nm (4.4 lbf ft) |
| Screw, connector board with combination instrument | M6 | 5 Nm (3.7 lbf ft) |
| Screw, fender | M6 | 12 Nm (8.9 lbf ft) |
| Screw, front brake disc | M6 | 14 Nm (10.3 lbf ft) Loctite®243™ |
| Screw, fuel tank spoiler on radiator | M6 | 6 Nm (4.4 lbf ft) |
| Screw, ground wire on frame | M6 | 10 Nm (7.4 lbf ft) |
| Screw, hand lever | M6 | 5 Nm (3.7 lbf ft) |
| Screw, push rod ball joint on the rear brake cylinder | M6 | 10 Nm (7.4 lbf ft) Loctite®243™ |

| | | |
|--|---------|---|
| Screw, rear brake disc | M6 | 14 Nm (10.3 lbf ft) Loctite®243™ |
| Screw, seat fixing | M6 | 8 Nm (5.9 lbf ft) |
| Screw, starter cable to starter relay | M6 | 6 Nm (4.4 lbf ft) |
| Screw, throttle grip | M6 | 5 Nm (3.7 lbf ft) |
| Brake lever stop nut | M8 | 20 Nm (14.8 lbf ft) |
| Nut, rear sprocket screw | M8 | 35 Nm (25.8 lbf ft) Loctite®2701™ |
| Nut, rim lock | M8 | 12 Nm (8.9 lbf ft) |
| Remaining nuts, chassis | M8 | 25 Nm (18.4 lbf ft) |
| Remaining screws, chassis | M8 | 25 Nm (18.4 lbf ft) |
| Screw, bottom triple clamp | M8 | 12 Nm (8.9 lbf ft) |
| Screw, chain sliding piece | M8 | 15 Nm (11.1 lbf ft) |
| Screw, engine sprocket cover | M8 | 15 Nm (11.1 lbf ft) |
| Screw, fork stub | M8 | 15 Nm (11.1 lbf ft) |
| Screw, front brake caliper | M8 | 25 Nm (18.4 lbf ft) Loctite®243™ |
| Screw, handlebar clamp | M8 | 20 Nm (14.8 lbf ft) |
| Screw, manifold on cylinder head brace | M8 | 15 Nm (11.1 lbf ft) |
| Screw, side stand attachment (All XC-F models) | M8 | 33 Nm (24.3 lbf ft) Loctite®2701™ |
| Screw, subframe bottom | M8 | 30 Nm (22.1 lbf ft) Loctite®2701™ |
| Screw, subframe top | M8 | 35 Nm (25.8 lbf ft) Loctite®2701™ |
| Screw, top steering stem | M8 | 20 Nm (14.8 lbf ft) Loctite®243™ |
| Screw, top triple clamp | M8 | 17 Nm (12.5 lbf ft) |
| Engine carrying screw | M10 | 60 Nm (44.3 lbf ft) |
| Remaining nuts, chassis | M10 | 45 Nm (33.2 lbf ft) |
| Remaining screws, chassis | M10 | 45 Nm (33.2 lbf ft) |
| Screw, bottom shock absorber | M10 | 60 Nm (44.3 lbf ft) Loctite®2701™ |
| Screw, handlebar support | M10 | 40 Nm (29.5 lbf ft) Loctite®243™ |
| Screw, top shock absorber | M10 | 60 Nm (44.3 lbf ft) Loctite®2701™ |
| Nut, angle lever to link fork | M16x1.5 | 60 Nm (44.3 lbf ft) |
| Nut, fork pivot | M16x1.5 | 100 Nm (73.8 lbf ft) |
| Nut, frame on linkage lever | M16x1.5 | 60 Nm (44.3 lbf ft) |
| Nut, linkage lever on angle lever | M16x1.5 | 60 Nm (44.3 lbf ft) |
| Screw, front wheel spindle | M20x1.5 | 35 Nm (25.8 lbf ft) |
| Screw, top steering head | M20x1.5 | 12 Nm (8.9 lbf ft) |
| Nut, rear wheel spindle | M22x1.5 | 80 Nm (59 lbf ft) |
| Screw-in fitting, cooling system | M24x1.5 | 7.5 Nm (5.53 lbf ft) |

Super unleaded (ROZ 95)

Standard/classification

- DIN EN 228 (ROZ 95)

Guideline

- Only use super unleaded fuel that matches or is equivalent to the specified standard.
- Fuel with an ethanol content of up to 10% (E10 fuel) is safe to use.



Info

Do **not** use fuel containing methanol (e.g., M15, M85, M100) or more than 10% ethanol (e.g., E15, E25, E85, E100).

Long-life grease

Recommended supplier

MOTOREX®

– Bike Grease 2000



3214878en

05.12.2023

