

250 EXC-F
250 EXC-F SIX DAYS

ART. NO. 3214915EN



Perform the work described in these setup instructions before the vehicle is delivered to the customer.

Read the setup instructions in their entirety before beginning work.

These setup instructions were written to correspond to the latest state of this model series. We reserve the right to make modifications in the interest of technical advancement without at the same time updating these setup instructions.

We shall not provide a description of general workshop methods. Likewise, safety rules that apply in a workshop are not specified here. It is assumed that the work will be performed by a fully trained mechanic.

All specifications contained herein are non-binding. KTM Sportmotorcycle GmbH specifically reserves the right to modify or delete technical specifications, prices, colors, forms, materials, services, designs, equipment, etc., without prior notice and without specifying reasons, to adapt these to local conditions, as well as to stop production of a particular model without prior notice. KTM accepts no liability for delivery options, deviations from figures and descriptions, misprints, and other errors. The models portrayed partly contain special equipment that does not belong to the regular scope of supply.

© 2023 KTM Sportmotorcycle GmbH, Mattighofen Austria

All rights reserved

Reproduction, even in part, as well as copying of all kinds, is permitted only with the express written permission of the copyright owner.



ISO 9001(12 100 6061)

KTM applies quality assurance processes that lead to the highest possible product quality as defined in the ISO 9001 international quality management standard.

Issued by: TÜV Management Service

REG.NO. 12 100 6061

KTM Sportmotorcycle GmbH
Stallhofnerstraße 3
5230 Mattighofen, Austria

This document is valid for the following models:

250 EXC-F EU (F8103X9)

250 EXC-F BR (F8140X9)

250 EXC-F SIX DAYS EU (F8103X2)



1 MEANS OF REPRESENTATION

1.1 Symbols used

The meaning of specific symbols is described below.



Indicates an expected reaction (e.g. of a work step or a function).



Indicates an unexpected reaction (e.g. of a work step or a function).



Indicates a page reference (more information is provided on the specified page).



Indicates information with more details or tips.



Indicates the result of a testing step.



Indicates a voltage measurement.



Indicates a current measurement.



Indicates a resistance measurement.



Indicates the end of an activity including potential rework.

1.2 Formats used

The typographical formats used in this document are explained below.

Proprietary name

Indicates a proprietary name.

Name®

Indicates a protected name.

Brand™

Indicates a brand available on the open market.

Underlined terms

Refer to technical details of the vehicle or indicate technical terms, which are explained in the glossary.

2.1 Transport mode

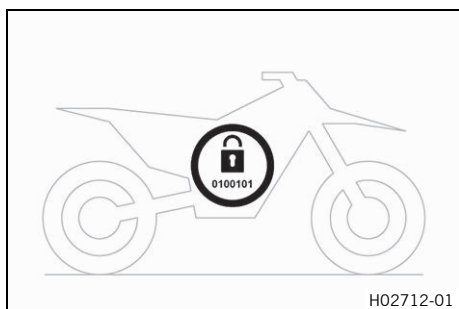

This vehicle was blocked for transport in the software. To operate the vehicle, the vehicle electronics must be enabled. This process is conducted during initial setup in KTM Dealer.net. Enabling ensures that the initial setup in KTM Dealer.net is documented.

Enabling can be performed either temporarily, e.g. for a test ride, or permanently for vehicle handover.

i Info

Make sure that the vehicle is permanently enabled before handing it over to the customer.

2.2 Diagnostics connector

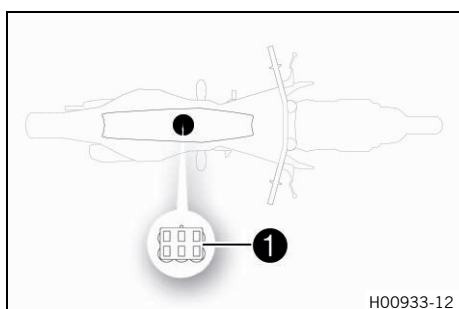

Diagnostics connector ① is located under the seat.

2.3 Unpacking and setting up the vehicle

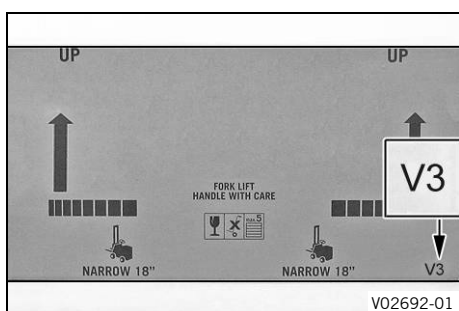

Condition

Packaging V3

- Remove the box and the plastic packaging.

i Info

To avoid damaging the motorcycle during the setup, leave the protective film on the vehicle until you have finished.

- Remove the separate enclosure and unpack it. Check that the scope of supply is complete using the enclosed packing list.

i Info

The procedure for missing components is described in the Customer Service Manual.

- Carefully loosen and remove the tension belts around the fork legs.
- Remove the attachment on the rear wheel.

i Info

An assistant prevents the motorcycle from falling over.

- Have a lift stand available.

Lift stand (78129955100)

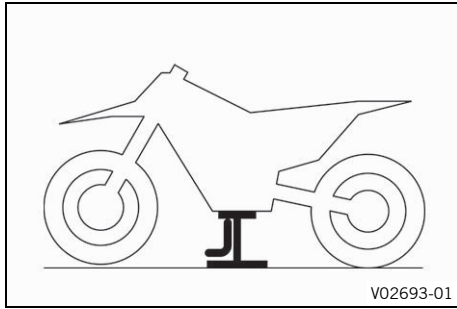

- Together with an assistant, take the vehicle off the pallet.
- Position the vehicle on a lift stand.
- Check the vehicle for transport damage.



Info

The procedure in the event of transport damage is described in the Customer Service Manual.

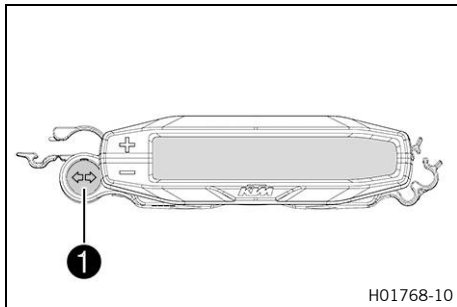

- Remove the headlight mask with the headlight. (📖 p. 15)
- Position turn signal indicator lamp **1** in the combination instrument rack.

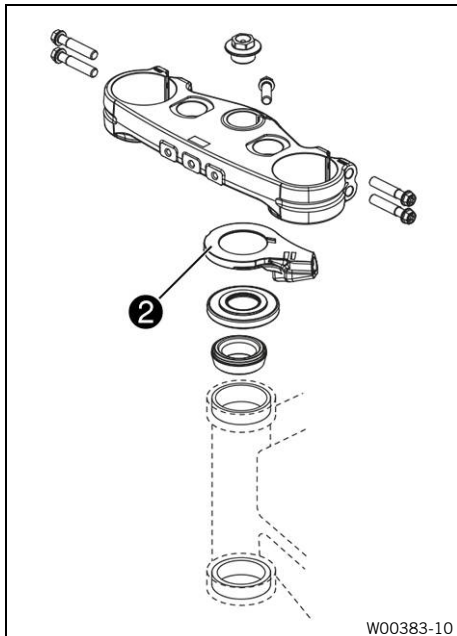

(EXC-F EU/BR)

- Loosen and lift upper triple clamp.
- Position steering lock **2**.
- Lower the upper triple clamp and fit it.

Guideline

Screw, top triple clamp	M8	20 Nm (14.8 lbf ft)
Screw, top steering stem	M8	20 Nm (14.8 lbf ft)

(EXC-F SIX DAYS)

- Loosen and lift upper triple clamp.
- Position steering lock **2**.
- Lower the upper triple clamp and fit it.

Guideline

Screw, top triple clamp	M8	17 Nm (12.5 lbf ft)
Screw, top steering stem	M8	17 Nm (12.5 lbf ft) Loctite®243™

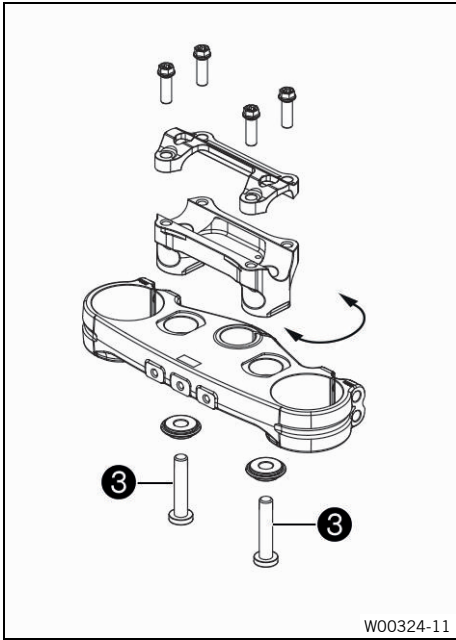

(EXC-F EU/BR)

- Remove screws **3** and take off the handlebar support.
- Move the handlebar support in the desired position and mount and tighten screws **3**.

Guideline

Screw, handlebar holder	M10	40 Nm (29.5 lbf ft) Loctite®243™
-------------------------	-----	--



Info

Position the handlebar support so that it is even.

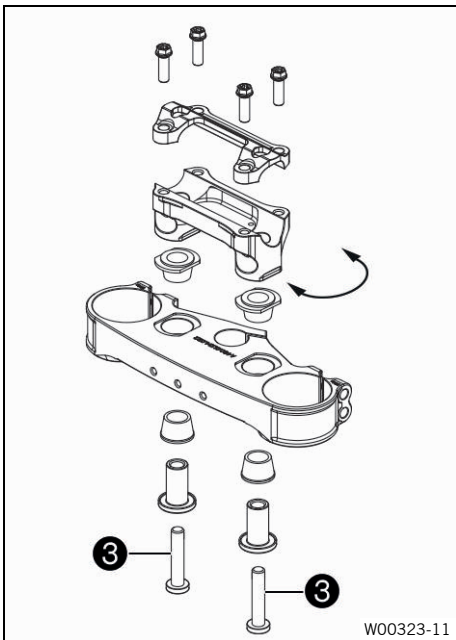

(EXC-F SIX DAYS)

- Remove screws **3** and take off the handlebar support.
- Move the handlebar support in the desired position and mount and tighten screws **3**.

Guideline

Screw, handlebar holder	M10	40 Nm (29.5 lbf ft) Loctite®243™
-------------------------	-----	--



Info

Position the handlebar support so that it is even.

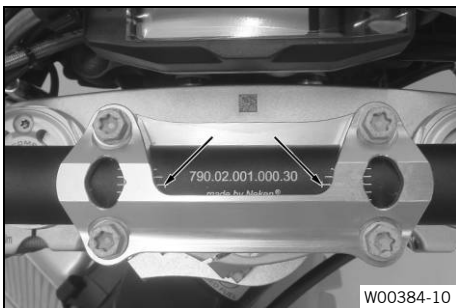

Warning

Danger of accidents A repaired handlebar poses a safety risk.

If the handlebar is bent or straightened, the material becomes fatigued. The handlebar may break as a result.

- Change the handlebar if the handlebar is damaged or bent.

- Position the handlebar.



Info

Make sure the cables and wiring are positioned correctly.

- Position the handlebar clamp. Mount and tighten the screws evenly.

Guideline

Screw, handlebar clamp	M8	20 Nm (14.8 lbf ft)
------------------------	----	---------------------



Info

The markings on the handlebar should be at the center of the handlebar clamp.

Keep the installed gap widths equal when tightening.



(All EU models)

- Position the controls on the right half of the handlebar.



(All EU models)

- Position the controls on the left handlebar half.

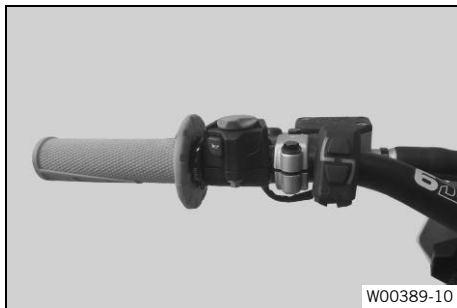

(EXC-F SIX DAYS)



Caution

Voiding of the government approval for road use and the insurance coverage If the combination switch is mounted, the vehicle's road permit, if any, expires.

- Only operate the vehicle in closed-off areas remote from public road traffic if the combination switch is installed.

- (Optional) Mount combination switch on the left side.



Info

The figure shows a possible installation position of the left side combination switch.

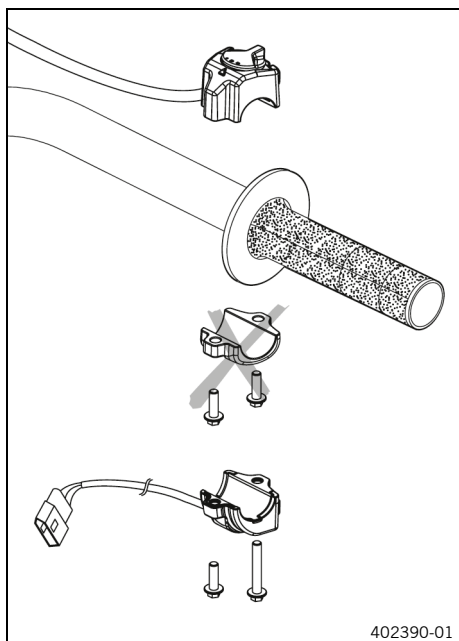

- Mount the turn signal switch.



(All EU models)

- Join all plug-in connectors to the connector board.
- Route the cable without tension and secure with quick release.

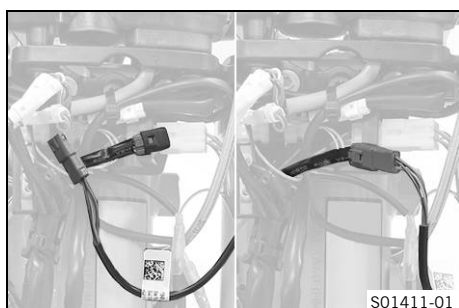

(EXC-F SIX DAYS)



Caution

Voiding of the government approval for road use and the insurance coverage If the combination switch is mounted, the vehicle's road permit, if any, expires.

- Only operate the vehicle in closed-off areas remote from public road traffic if the combination switch is installed.

- (Optional) Remove the protection cap and join the plug-in connector of the left combination switch.

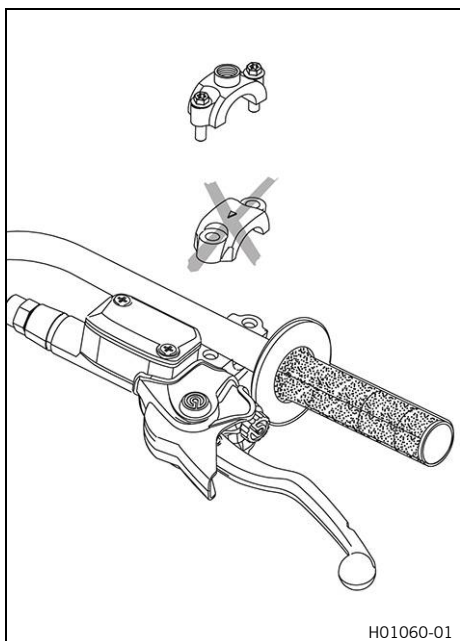

- Mount the mirror clamps on both sides.

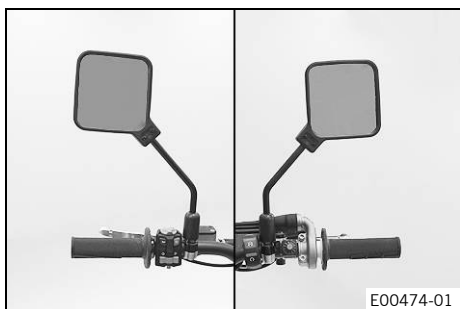

- Mount both rear mirrors with the adapter.



- Preassemble the hand guards on the left and right.



- Mount the left hand guard.
- Mount the right hand guard.

F01077-10



- Fix the handlebar cushion to the handlebar clamp.
- Install the front fender. (📖 p. 17)
- Remove the seat. (📖 p. 18)
- Remove the 12-V battery. (📖 p. 22)

(All EU models)

- Charge the 12-V battery. (📖 p. 26)

Guideline

The 12-V battery must be fully charged before it is handed over to the customer.



Info

The first charging process may take longer with a new 12-V battery.

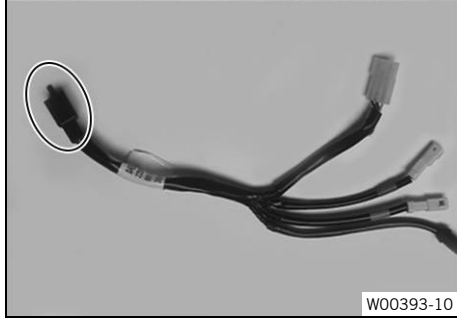

W00393-10



W00394-10



W00395-10

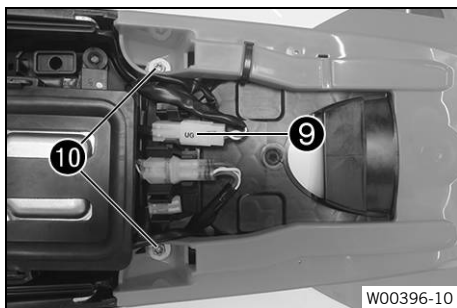

W00396-10

(All EU models)

- Connect plug 4 with turn signal wiring harness.

- Insert the black and violet cables of the bulb included in the separate enclosure into the socket and position it in the turn signal indicator lamp.

- Position the turn signal on the headlight mask on both sides, mount nuts with washers and tighten.
- Join plug-in connector 5 of the left turn signal using the violet and brown cable colors of the turn signal cable harness.
- Join plug-in connector 6 of the right turn signal using the black and brown cable colors of the turn signal cable harness.
- Join plug-in connector 7 of the headlight.
- Connect plug-in connector 8 of the turn signal switch.
- Install the headlight mask with the headlight. (p. 16)
- Disconnect tail light plug-in connector 9 on the wiring harness.
- Remove screws 10.

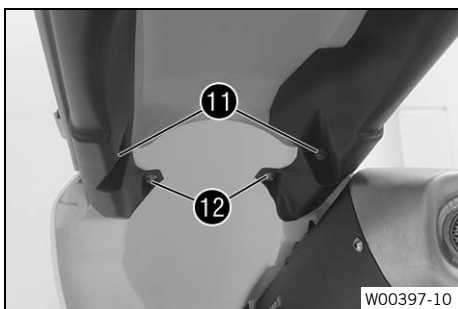

- Remove screws 11.
- Remove screws 12.
- Remove the license plate holder with the tail light.



Info

Pay attention to the cable of the tail light.

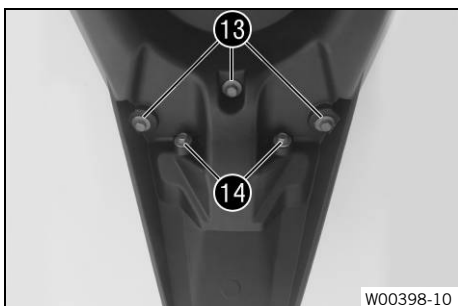

- Loosen screws 13 and remove license plate holder from fender.
- Loosen screws 14 and hang the tail light to the side.

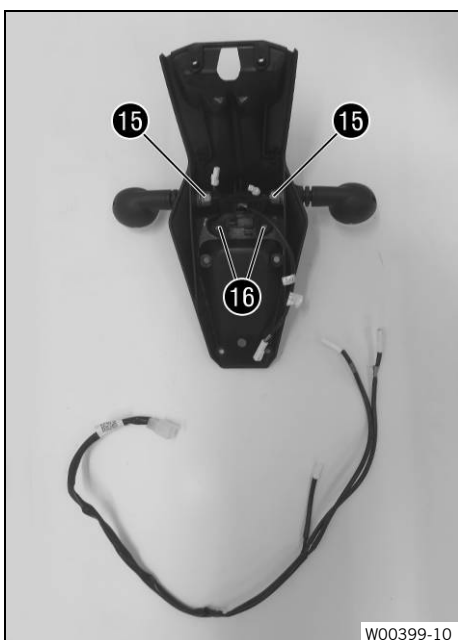

- Position the turn signal on both sides on the license plate holder, mount nuts 15 with washers and tighten.
- Position the license plate lamp on the license plate holder, and mount and tighten screws 16.
- Connect the plug-in connections of the turn signals and the license plate lamp with the wiring harness.



- Drill a hole at marking A on the license plate holder to the size of the marking.

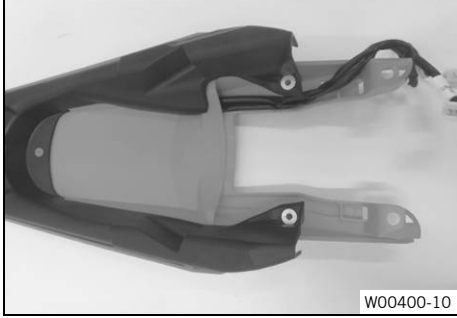
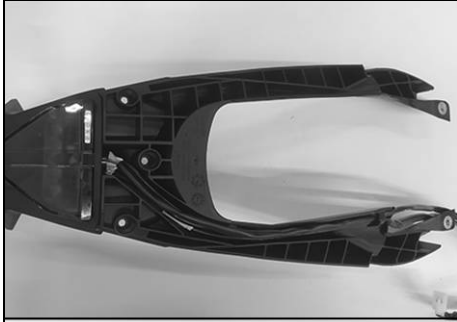

W00400-10

- Position the tail light together with the license plate holder on the license plate bracket.

i Info
Ensure that the cables are routed correctly.

- Position the fender on the license plate holder.

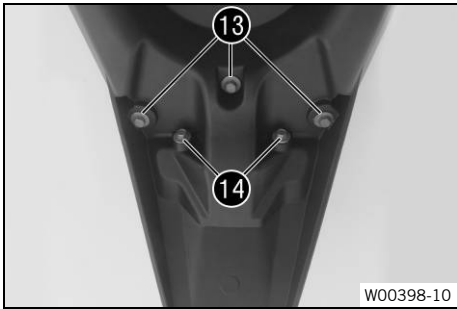

W00398-10

- Mount and tighten screws **14**.
- Mount and tighten screws **13**.

Guideline

Remaining screws, chassis	EJOT PT® K60x25-Z	2 Nm (1.5 lbf ft)
---------------------------	-----------------------------	-------------------

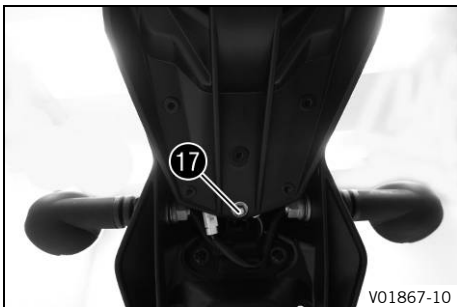

V01867-10

- Mount and tighten screw **17**.

Guideline

Remaining screws, chassis	EJOT PT® K60x25-Z	2 Nm (1.5 lbf ft)
---------------------------	-----------------------------	-------------------

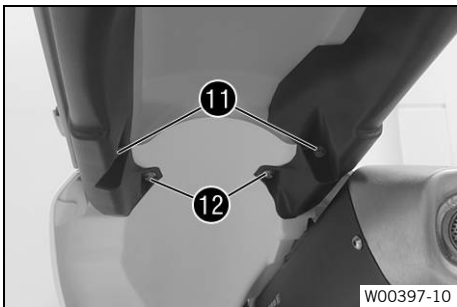

W00397-10

- Slide license plate holder onto tail section and position.

i Info
Ensure that the cables are routed correctly.

- Mount and tighten screws **12**.

Guideline

Remaining screws, chassis	M6	10 Nm (7.4 lbf ft)
---------------------------	----	--------------------

- Mount and tighten screws **11**.

Guideline

Remaining screws, chassis	EJOT PT® K60x25-Z	2 Nm (1.5 lbf ft)
---------------------------	-----------------------------	-------------------

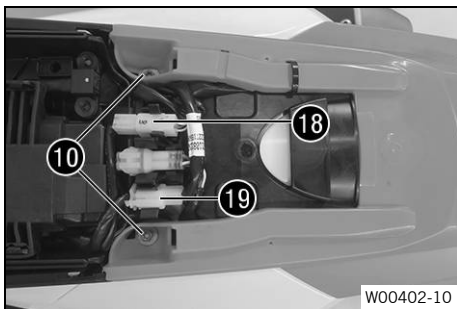

W00402-10

- Mount and tighten screws 10.

Guideline

Remaining screws, chassis	M6	10 Nm (7.4 lbf ft)
---------------------------	----	--------------------

- Join the plug-in connectors of tail light 18 and turn signal cable harness 19 with the wiring harness.



Info

Pay attention to routing of the wiring harnesses.

- Install the 12-V battery. (📖 p. 24)
- Mount the seat. (📖 p. 18)
- Position the right footrest and pin.



Info

Only insert the pin to the extent that the spring can still be mounted.



W00574-10

- Position spring as shown.
 - ✓ Spring B engages in area C.

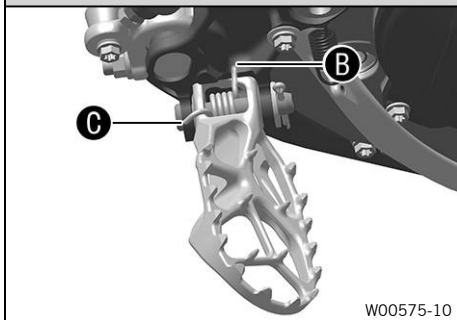
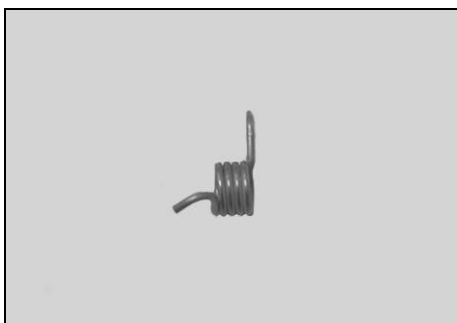

W00575-10

- Apply pressure to the spring with your thumb.
- Mount pin 20.

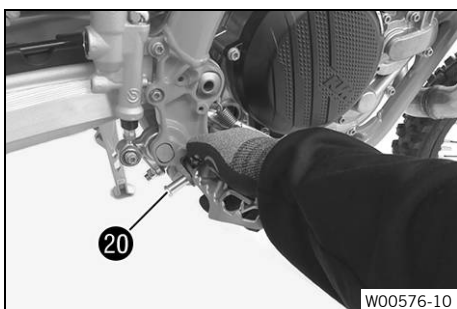

W00576-10

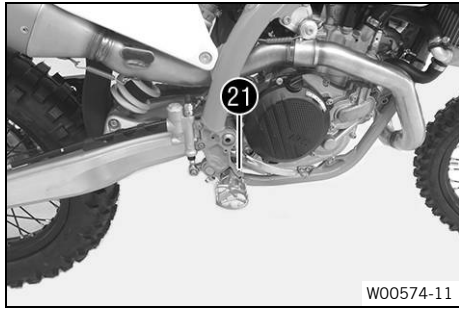

- Mount the washer and splint **21**.
- Repeat these steps on the opposite side.
- Install the frame protector. (📖 p. 29)

(EXC-F SIX DAYS)

- Install the engine guard. (📖 p. 29)
- Unpack and mount the **KTM PowerParts** included in the delivery (optional).



Info

Read the accompanying **KTM PowerParts** fitting instructions.

- Attach the stickers included in the scope of supply (optional).
- Set kilometers or miles. (📖 p. 31)
- Set the combination instrument. (📖 p. 32)
- Set the clock. (📖 p. 33)
- Refuel. (📖 p. 30)
- Position all controls in their exact positions on the handlebar. Tighten all screws.
- Prepare the vehicle according to the specifications in **KTM Dealer.net** for handover to the customer.



Info

Transport mode must be deactivated to be able to start the motorcycle.

3.1 Raising the motorcycle with the lift stand

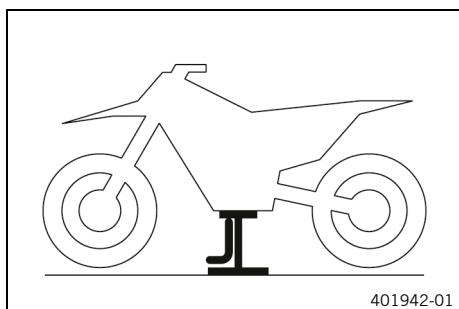

Note

Danger of damage The parked vehicle can roll away or fall over.

- Park the vehicle on a firm and level surface.
- Raise the motorcycle at the frame underneath the engine.

Lift stand (78129955100)

- ✓ Neither wheel is in contact with the ground.
- Secure the motorcycle against falling over.



3.2 Removing the motorcycle from the lift stand

Note

Danger of damage The parked vehicle can roll away or fall over.

- Park the vehicle on a firm and level surface.

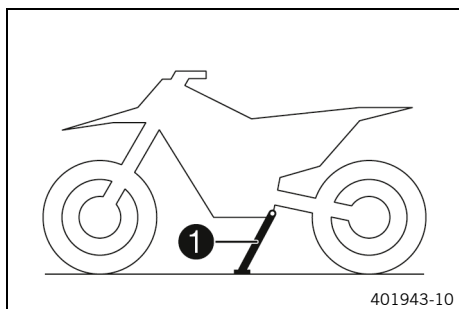

- Remove the motorcycle from the lift stand.
- Remove the lift stand.
- To park the motorcycle, press side stand **1** to the ground with your foot and lean the motorcycle on it.



Info

When you are riding, the side stand must be folded up and secured with rubber strap.



3.3 Removing the headlight mask with the headlight



- Loosen screws **1**.
- Slide the headlight mask up and swing it forward.
- Detach the brake line and wiring harness from the headlight mask.

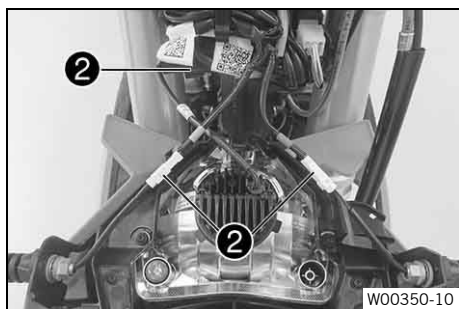

- Detach plug-in connectors **2** and take off the headlight mask with the headlight.



3.4 Installing the headlight mask with the headlight

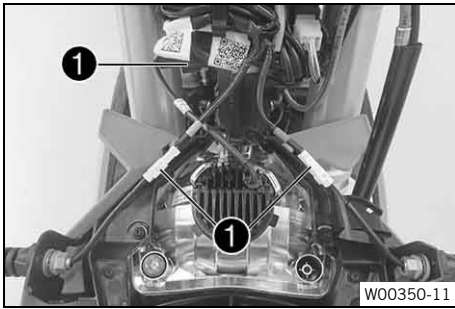

Main work

- Join plug-in connectors **1**.

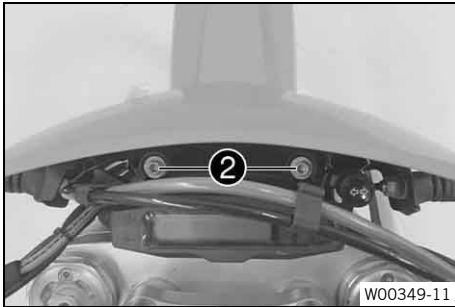

- Position the brake line and wiring harness in the brake line guide.
- Position the headlight mask.
- ✓ The holding lugs engage in the fender.
- Mount and tighten screws **2**.

Guideline

Remaining nuts, chassis	M6	10 Nm (7.4 lbf ft)
-------------------------	----	--------------------

Finishing work

- Check the headlight setting. (📖 p. 16)

3.5 Checking the headlight setting

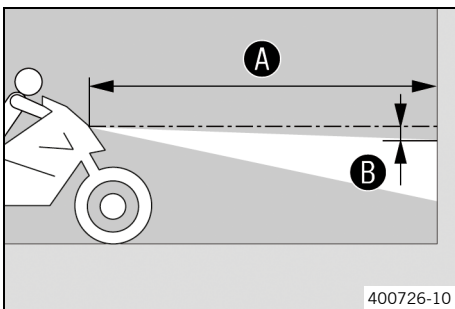

- Position the vehicle upright on a horizontal surface in front of a light wall and make a marking at the height of the center of the low beam headlight.
- Make another mark at a distance **B** under the first marking.

Guideline

Distance B	5 cm (2 in)
-------------------	-------------

- Position the vehicle vertically at a distance **A** away from the wall.

Guideline

Distance A	5 m (16 ft)
-------------------	-------------

- The rider now sits down on the motorcycle.
- Switch on the low beam.
- Check the headlight setting.

The boundary between light and dark must be exactly on the lower mark for a motorcycle with rider.

- » If the boundary between light and dark does not meet specifications:
 - Adjust the headlight range. (📖 p. 17)

3.6 Adjusting the headlight range

Preparatory work

- Check the headlight setting. (📖 p. 16)

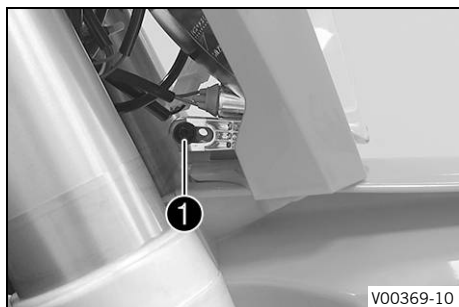

Main work

- Loosen screw ❶.
- Adjust the headlight range by pivoting the headlight.

Guideline

The boundary between light and dark must be exactly on the lower mark for a motorcycle with rider (instructions on how to apply the mark: Checking the headlight setting).

i Info

A change in weight on the vehicle may require a correction of the headlight range.

- Tighten screw ❶.



3.7 Installing the front fender

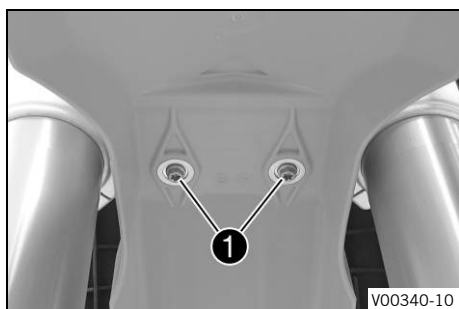

Main work

- Position the front fender. Mount and tighten screws ❶.

Guideline

Remaining screws, chassis	M6	10 Nm (7.4 lbf ft)
---------------------------	----	--------------------

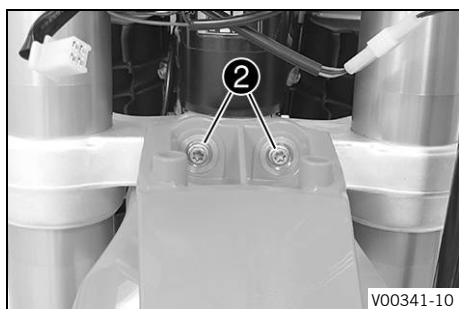

- Mount and tighten screws ❷.

Guideline

Remaining screws, chassis	M6	10 Nm (7.4 lbf ft)
---------------------------	----	--------------------

Finishing work

- Install the headlight mask with the headlight. (📖 p. 16)
- Check the headlight setting. (📖 p. 16)



3.8 Removing the seat

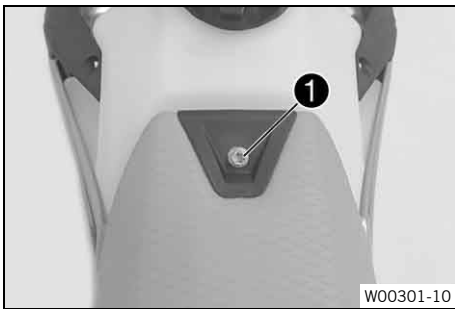

- Remove screw ❶.

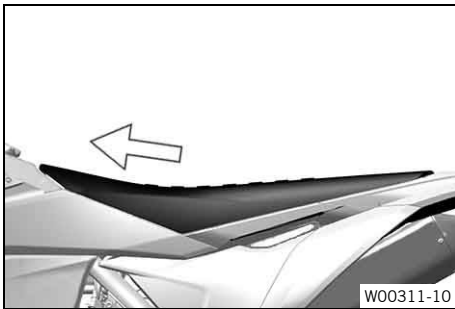

- Pull seat toward the fuel tank and lift it off.

3.9 Mounting the seat

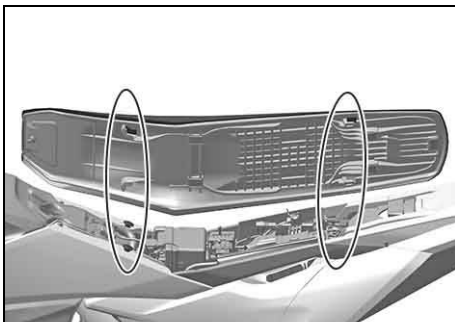

- Mount the front of the seat on the collar bushings of the fuel tank, lower the seat at the rear, and push the seat to the rear.
 - ✓ The holding lugs engage in the recesses at the back.
- Make sure the seat is latched in place correctly.

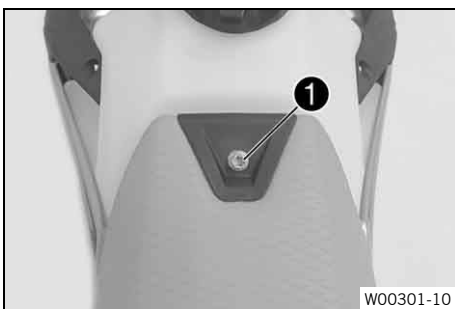
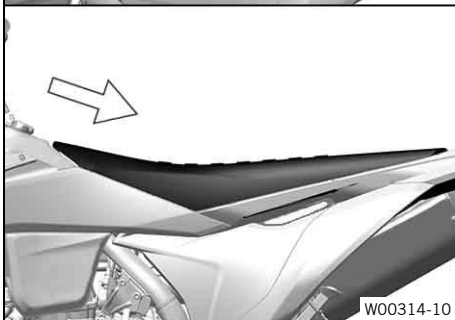

- Mount and tighten screw ❶.

Guideline

Remaining screws, chassis	M6	10 Nm (7.4 lbf ft)
---------------------------	----	--------------------

3.10 Removing the fuel tank



Danger

Fire hazard Fuel is highly flammable.

The fuel in the fuel tank expands when warm and can escape if overfilled.

- Do not fuel the vehicle in the vicinity of open flames or lit cigarettes.
- Switch off the engine for refueling.
- Make sure that no fuel is spilled; particularly not on hot parts of the vehicle.
- If any fuel is spilled, wipe it off immediately.
- Observe the specifications for refueling.



Warning

Danger of poisoning Fuel is harmful to health.

- Avoid skin, eye and clothing contact with fuel.
- Immediately consult a doctor if you swallow fuel.
- Do not inhale fuel vapors.
- Rinse the affected area immediately with plenty of water in the event of contact with the skin.
- Rinse the eyes thoroughly with water, and consult a doctor in case of fuel contact with the eyes.
- Change your clothing if fuel spills on them.
- Keep fuels correctly in a suitable canister, and out of the reach of children.

Preparatory work

- Remove the seat. (📖 p. 18)

Main work

- Clean quick release coupling ① thoroughly with compressed air.

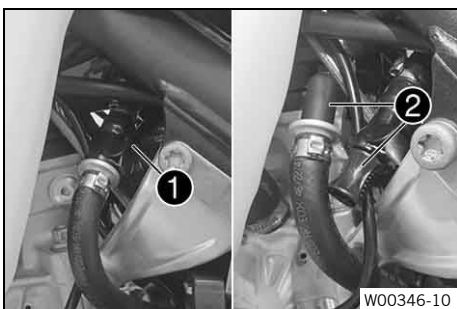

Info

Under no circumstances should dirt enter into the fuel line. Dirt in the fuel line clogs the injection valve!

- Disconnect the quick release coupling.



Info

Remaining fuel may flow out of the fuel line.

- Mount wash cap set ②.

Wash cap set (81212016100)

- Unplug fuel pump connector ③.
- Remove screw ④ with the rubber bushing.
- Remove the hose from the fuel tank breather.

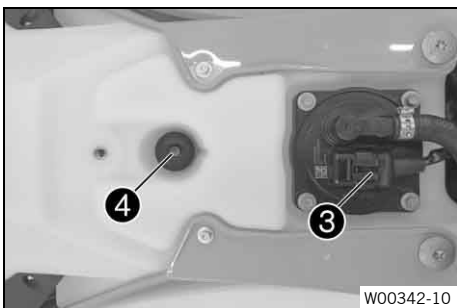

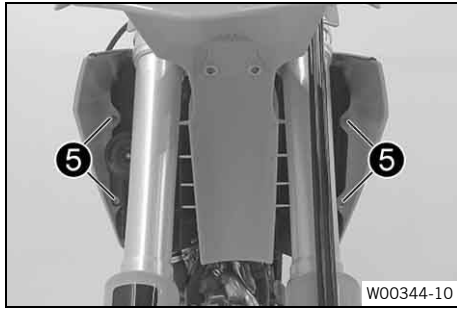

- Remove screws 5.
- Hang the horn and horn bracket to one side.

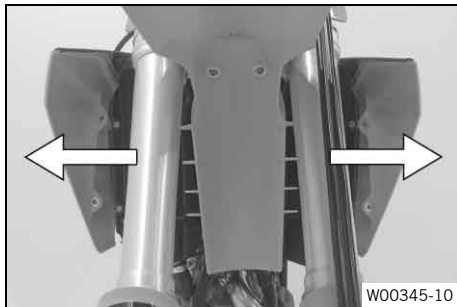

- Pull both spoilers laterally off the radiator and lift off the fuel tank.

3.11 Installing the fuel tank



Danger

Fire hazard Fuel is highly flammable.

The fuel in the fuel tank expands when warm and can escape if overfilled.

- Do not fuel the vehicle in the vicinity of open flames or lit cigarettes.
- Switch off the engine for refueling.
- Make sure that no fuel is spilled; particularly not on hot parts of the vehicle.
- If any fuel is spilled, wipe it off immediately.
- Observe the specifications for refueling.



Warning

Danger of poisoning Fuel is harmful to health.

- Avoid skin, eye and clothing contact with fuel.
- Immediately consult a doctor if you swallow fuel.
- Do not inhale fuel vapors.
- Rinse the affected area immediately with plenty of water in the event of contact with the skin.
- Rinse the eyes thoroughly with water, and consult a doctor in case of fuel contact with the eyes.
- Change your clothing if fuel spills on them.

Main work

- Check the throttle cable routing. (📖 p. 22)

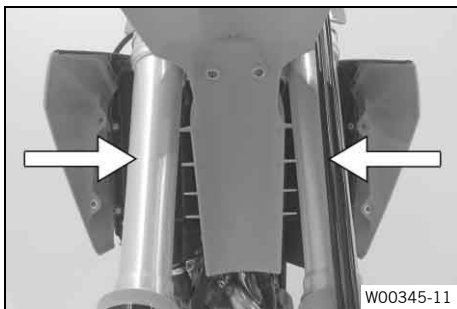

- Position the fuel tank and fit the two spoilers to the sides in front of the radiator bracket.
- Make sure that no cables or throttle cables are trapped or damaged.

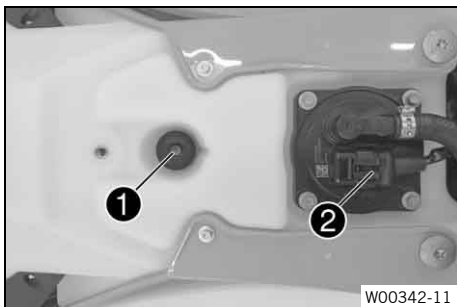

- Attach the fuel tank breather hose.
- Mount and tighten screw 1 with the rubber bushing.

Guideline

Remaining screws, chassis	M6	10 Nm (7.4 lbf ft)
---------------------------	----	--------------------

- Plug in fuel pump connector 2.

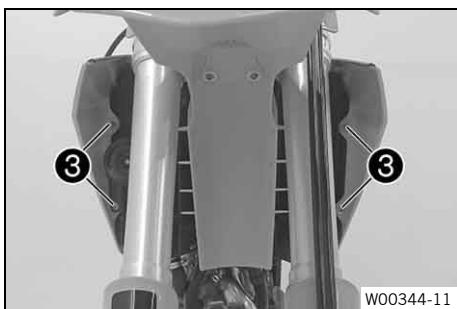

- Position the horn with the horn bracket.
- Mount and tighten screws 3.

Guideline

Remaining screws, chassis	M6	10 Nm (7.4 lbf ft)
---------------------------	----	--------------------



- Remove the wash cap set.
- Clean the quick release coupling thoroughly with compressed air.

i Info
Under no circumstances should dirt enter into the fuel line. Dirt in the fuel line clogs the injection valve!

- Spray silicone spray onto a lint-free cleaning cloth and lightly lubricate the O-ring of the quick-release coupling.

Silicone spray (📖 p. 37)

- Join quick release coupling 4.

i Info
Route the cable and fuel line at a safe distance from the exhaust system.

Finishing work

- Mount the seat. (📖 p. 18)

3.12 Checking the throttle cable routing



Warning

Danger of accidents The throttle cable can become kinked, trapped or blocked if it is not routed correctly.

If the throttle cable is kinked, trapped or blocked, the speed can no longer be controlled.

- Make sure that the throttle cable routing and the play in throttle cable complies with the specification.

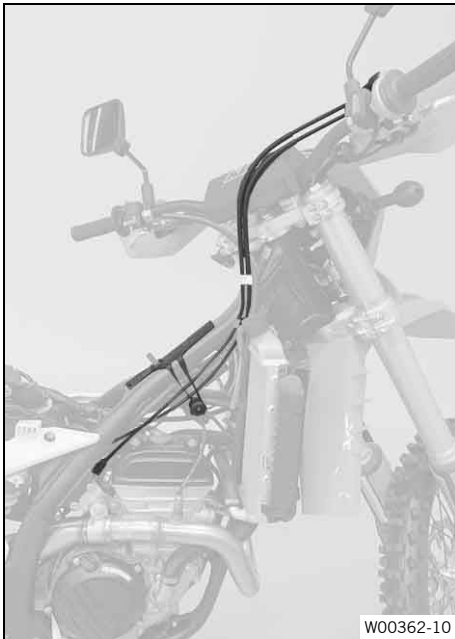

Preparatory work

- Remove the seat. (📖 p. 18)
- Remove the fuel tank. (📖 p. 19)

Main work

- Check the throttle cable routing.

Both throttle cables must be routed, side by side, on the back of the handlebars and above the fuel tank bracket, to the throttle valve body. Both throttle cables must be secured behind the rubber strap of the fuel tank support.

- » If the throttle cable routing is not as specified:
 - Correct the throttle cable routing.

Finishing work

- Install the fuel tank. (📖 p. 20)
- Mount the seat. (📖 p. 18)

3.13 Removing the 12-V battery



Note

Environmental hazard 12 V batteries contain environmentally hazardous materials.

- Do not dispose of 12 V batteries as household waste.
- Dispose of 12 V batteries at a collection point for used batteries.



Note

Environmental hazard Hazardous substances cause environmental damage.

- Dispose of oils, grease, filters, fuel, cleaning agents, brake fluid, etc., correctly and in compliance with the applicable regulations.

Preparatory work

- Remove the seat. (📖 p. 18)
- Remove the fuel tank. (📖 p. 19)

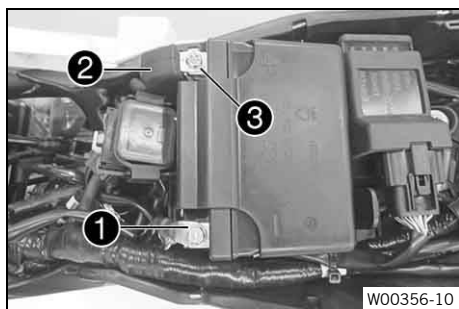

Main work (All EU models)



Warning

Risk of injury 12 V batteries contain harmful substances.

- Keep 12 V batteries out of the reach of children.
- Keep sparks and open flames away from 12 V batteries.
- Only charge 12 V batteries in well-ventilated rooms.
- Maintain a minimum clearance from inflammable materials when charging 12 V batteries.

Minimum clearance 1 m (3 ft)

- Do not charge deeply discharged 12 V batteries if the charge is already below the minimum voltage.

Minimum voltage 9 V
before the start of the charge

- Dispose of 12 V batteries correctly if they have less than the minimum voltage.

- Disconnect negative cable ① from the 12-V battery.
- Pull back positive terminal cover ② and disconnect positive cable ③ from the 12-V battery.

(EXC-F BR)



Warning

Risk of injury Battery acid and battery gases cause serious chemical burns.

- Keep 12 V batteries out of the reach of children.
- Wear suitable protective clothing and safety glasses.
- Avoid contact with battery acid and battery gases.
- Keep sparks or open flames away from the 12 V battery.
- Only charge 12 V batteries in well-ventilated rooms.
- Rinse the affected area immediately with plenty of water in the event of contact with the skin.
- Rinse eyes with water for at least 15 minutes and consult a doctor immediately if battery acid and battery gases get into the eyes.

- Disconnect negative cable ① from the 12-V battery.

- Pull back positive terminal cover **2** and disconnect positive cable **3** from the 12-V battery.
- Remove screw **4**.

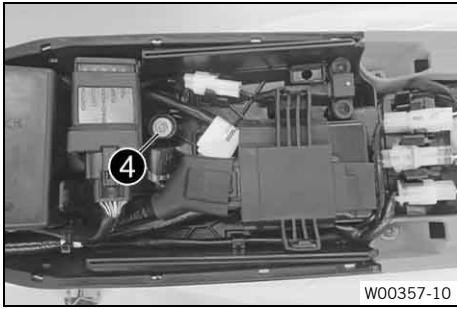

- Pull up battery holding bracket **5** and remove the 12-V battery to the rear.

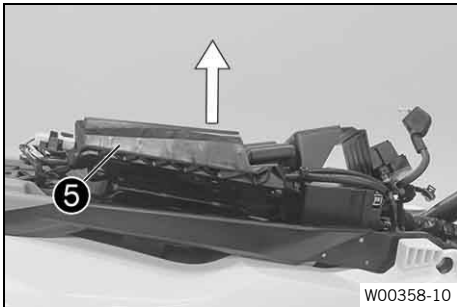

i Info
Pay attention to the wiring harness.

3.14 Installing the 12-V battery

Main work

- Pull up battery holding bracket **1**, insert the 12-V battery into the battery compartment with the terminals facing upward and secure with battery holding bracket **1**.

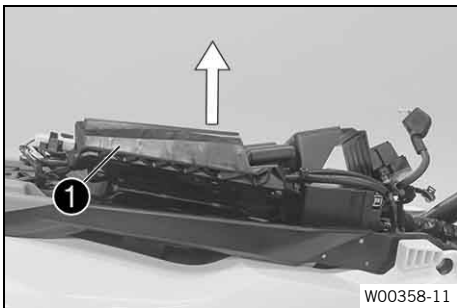

(All EU models)

12 V battery (HJTZ5S-FP-C)

(EXC-F BR)

12 V battery (YTX5L-BS)

i Info
Ensure that the cable is routed correctly.

- Mount and tighten screw **2**.

Guideline

Screw, battery holding bracket	M6	6 Nm (4.4 lbf ft)
--------------------------------	----	-------------------

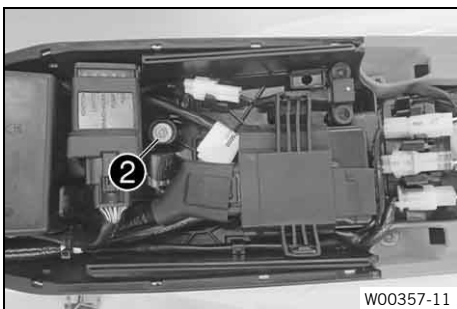

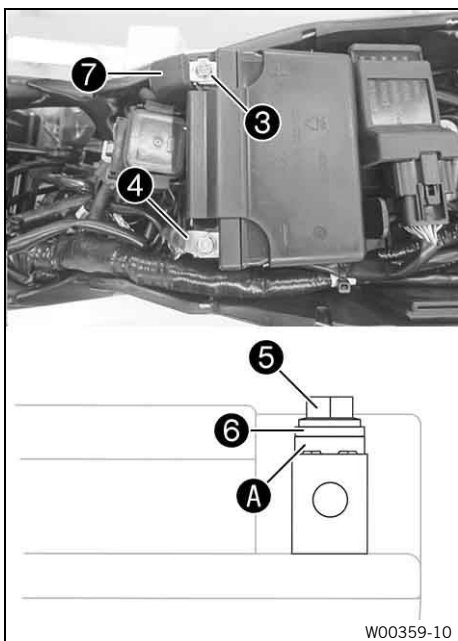

- Connect positive cable ③ to the 12-V battery.

Guideline

Screw, battery terminal	M5	2.5 Nm (1.84 lbf ft)
-------------------------	----	-------------------------

- Connect negative cable ④ to the 12 V battery.

Guideline

Screw, battery terminal	M5	2.5 Nm (1.84 lbf ft)
-------------------------	----	-------------------------

Contact disks A must be mounted under screws ⑤ and cable sockets ⑥ with the claws toward the battery terminal.

- Slide positive terminal cover ⑦ over the positive terminal.

Finishing work

- Install the fuel tank. (📖 p. 20)
- Mount the seat. (📖 p. 18)

3.15 Disconnecting the negative cable of the 12-V battery

Preparatory work

- Remove the seat. (📖 p. 18)

Main work

- Disconnect negative cable ① of the 12-V battery.

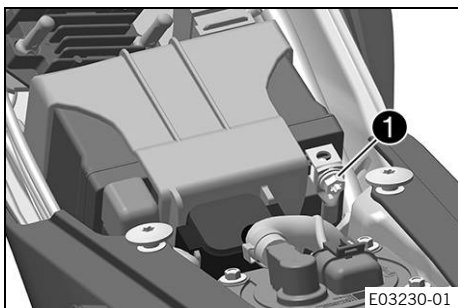

3.16 Connecting the negative cable of the 12-V battery

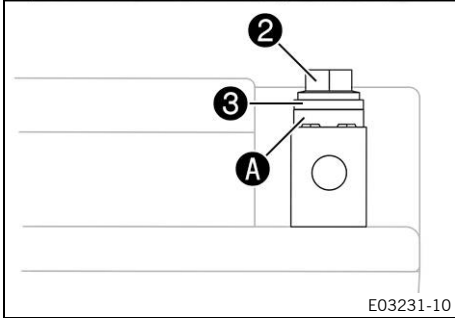
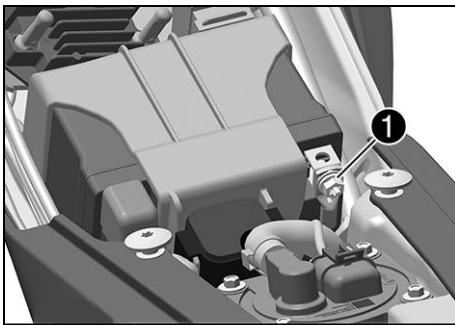

E03231-10

Main work

- Connect negative cable **1** of the 12-V battery.

Guideline

Screw, battery terminal	M5	2.5 Nm (1.84 lbf ft)
-------------------------	----	-------------------------

Contact disk **A** must be mounted under screw **2** and cable lug **3** with the claws toward the battery terminal.

Finishing work

- Mount the seat. (📖 p. 18)

3.17 Charging the 12-V battery (All EU models)



Warning

Risk of injury 12 V batteries contain harmful substances.

- Keep 12 V batteries out of the reach of children.
- Keep sparks and open flames away from 12 V batteries.
- Only charge 12 V batteries in well-ventilated rooms.
- Maintain a minimum clearance from inflammable materials when charging 12 V batteries.
Minimum clearance 1 m (3 ft)
- Do not charge deeply discharged 12 V batteries if the charge is already below the minimum voltage.
Minimum voltage before the start of the charge 9 V
- Dispose of 12 V batteries correctly if they have less than the minimum voltage.

Note

Danger of damage An incorrectly selected charging mode will damage the 12-V battery.

- Always select a charging mode that is compatible with the type of battery.



Note

Environmental hazard 12 V batteries contain environmentally hazardous materials.

- Do not dispose of 12 V batteries as household waste.
- Dispose of 12 V batteries at a collection point for used batteries.



Note

Environmental hazard Hazardous substances cause environmental damage.

- Dispose of oils, grease, filters, fuel, cleaning agents, brake fluid, etc., correctly and in compliance with the applicable regulations.

i Info

Even when there is no load on the 12-V battery, it discharges steadily each day. The charging level and the method of charging are very important for the service life of the 12-V battery. Rapid recharging with a high charging current shortens the service life of the battery. If the charging current, charging voltage, and charging time are exceeded, the 12-V battery will be destroyed. If the 12-V battery is depleted from starting the vehicle repeatedly, the battery must be charged immediately. If the 12-V battery is left in a discharged state for an extended period, it will become deeply discharged and suffer a loss of capacity, destroying the battery. The 12-V battery is maintenance-free.

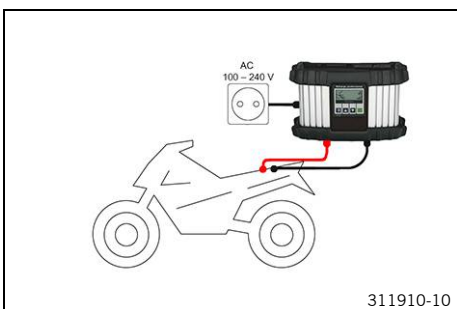

Preparatory work

- Remove the seat. (📖 p. 18)
- Disconnect the negative cable of the 12-V battery. (📖 p. 25)

Main work

- Connect a battery charger to the 12-V battery. Adjust the battery charger.

EU battery charger **XCharge-professional** (00029095050)

Alternative 1

US battery charger **XCharge-professional** (00029095051)

Alternative 2

UK battery charger **XCharge-professional** (00029095052)

i Info

Follow the instructions of the charger and the manual.

- Disconnect the battery charger after charging the 12-V battery. Guideline

The charging current, charging voltage, and charging time must not be exceeded.	
Recharge the 12-V battery regularly when the motorcycle is not being used	3 months

Finishing work

- Connect the negative cable of the 12-V battery. (📖 p. 26)
- Mount the seat. (📖 p. 18)



3.18 Charging the 12-V battery (EXC-F BR)



Warning

Risk of injury Battery acid and battery gases cause serious chemical burns.

- Keep 12 V batteries out of the reach of children.
- Wear suitable protective clothing and safety glasses.
- Avoid contact with battery acid and battery gases.
- Keep sparks or open flames away from the 12 V battery.
- Only charge 12 V batteries in well-ventilated rooms.
- Rinse the affected area immediately with plenty of water in the event of contact with the skin.
- Rinse eyes with water for at least 15 minutes and consult a doctor immediately if battery acid and battery gases get into the eyes.

Note

Danger of damage An incorrectly selected charging mode will damage the 12-V battery.

- Always select a charging mode that is compatible with the type of battery.



Note

Environmental hazard 12 V batteries contain environmentally hazardous materials.

- Do not dispose of 12 V batteries as household waste.
- Dispose of 12 V batteries at a collection point for used batteries.



Note

Environmental hazard Hazardous substances cause environmental damage.

- Dispose of oils, grease, filters, fuel, cleaning agents, brake fluid, etc., correctly and in compliance with the applicable regulations.



Info

Even when there is no load on the 12-V battery, it discharges steadily each day.

The charging level and the method of charging are very important for the service life of the 12-V battery.

Rapid recharging with a high charging current shortens the service life of the battery.

If the charging current, charging voltage, or charging time is exceeded, the 12-V battery will be destroyed.

If the 12-V battery is depleted by repeated starting, the 12-V battery must be charged immediately.

If the 12-V battery is left in a discharged state for an extended period, it will become deeply discharged and sulfating occurs, destroying the battery.

The 12-V battery is maintenance-free, i.e. the acid level does not have to be checked.

Preparatory work

- Remove the seat. (📖 p. 18)
- Disconnect the negative cable of the 12-V battery. (📖 p. 25)

Main work

- Connect a battery charger to the 12-V battery. Adjust the battery charger.

EU battery charger **XCharge-professional** (00029095050)

Alternative 1

US battery charger **XCharge-professional**
(00029095051)

Alternative 2

UK battery charger **XCharge-professional**
(00029095052)

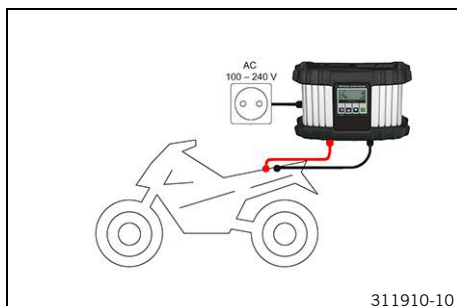

i Info
Follow the instructions of the charger and the manual.

- Disconnect the battery charger after charging the 12-V battery.
- Guideline

The charging current, charging voltage, and charging time must not be exceeded.	
Recharge the 12-V battery regularly when the motorcycle is not being used	3 months

Finishing work

- Connect the negative cable of the 12-V battery. (📖 p. 26)
- Mount the seat. (📖 p. 18)



3.19 Installing the engine guard (EXC-F SIX DAYS)

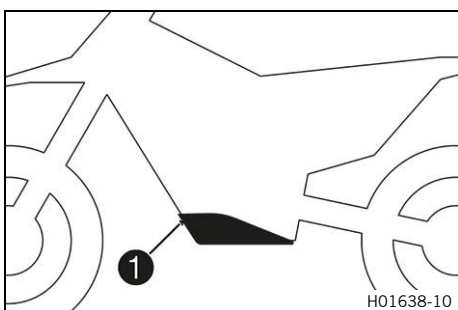

- Attach the engine guard on the frame at the rear and swing up at the front.
- Mount and tighten screws ①.

Guideline

Remaining screws, chassis	M6	10 Nm (7.4 lbf ft)
---------------------------	----	--------------------



3.20 Installing the frame protector

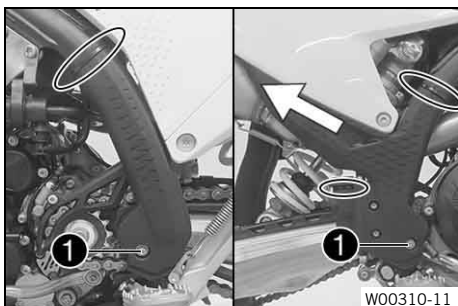

- Position the left frame protector.
- Insert the right frame protector from below and push it to the rear.
- Mount screws ① with the bushings and tighten.

Guideline

Screw, frame protector	M5	3 Nm (2.2 lbf ft)
------------------------	----	-------------------

- Secure the frame protector with cable ties.



3.21 Opening fuel tank filler cap



Danger

Fire hazard Fuel is highly flammable.

The fuel in the fuel tank expands when warm and can escape if overfilled.

- Do not fuel the vehicle in the vicinity of open flames or lit cigarettes.
- Switch off the engine for refueling.
- Make sure that no fuel is spilled; particularly not on hot parts of the vehicle.
- If any fuel is spilled, wipe it off immediately.
- Observe the specifications for refueling.



Warning

Danger of poisoning Fuel is harmful to health.

- Avoid skin, eye and clothing contact with fuel.
- Immediately consult a doctor if you swallow fuel.
- Do not inhale fuel vapors.
- Rinse the affected area immediately with plenty of water in the event of contact with the skin.
- Rinse the eyes thoroughly with water, and consult a doctor in case of fuel contact with the eyes.
- Change your clothing if fuel spills on them.
- Keep fuels correctly in a suitable canister, and out of the reach of children.



Note

Environmental hazard Improper handling of fuel is a danger to the environment.

- Do not allow fuel to enter the groundwater, the soil, or the sewage system.



- Press release button **1**, turn the fuel tank filler cap counter-clockwise, and lift it off.

3.22 Closing the fuel tank filler cap

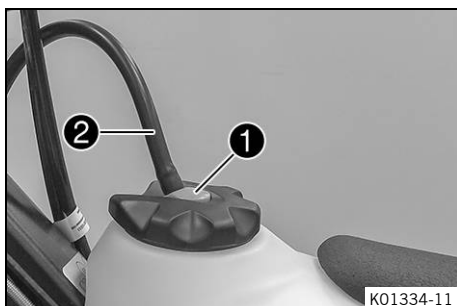

- Mount fuel tank filler cap and turn it clockwise until the release button **1** engages.



Info

Route fuel tank breather hose **2** without kinks.

3.23 Refueling



Danger

Fire hazard Fuel is highly flammable.

The fuel in the fuel tank expands when warm and can escape if overfilled.

- Do not fuel the vehicle in the vicinity of open flames or lit cigarettes.
- Switch off the engine for refueling.
- Make sure that no fuel is spilled; particularly not on hot parts of the vehicle.
- If any fuel is spilled, wipe it off immediately.
- Observe the specifications for refueling.



Warning

Danger of poisoning Fuel is harmful to health.

- Avoid skin, eye and clothing contact with fuel.
- Immediately consult a doctor if you swallow fuel.
- Do not inhale fuel vapors.
- Rinse the affected area immediately with plenty of water in the event of contact with the skin.
- Rinse the eyes thoroughly with water, and consult a doctor in case of fuel contact with the eyes.
- Change your clothing if fuel spills on them.

Note

Material damage Inadequate fuel quality causes the fuel filter to quickly become clogged.

In some countries and regions, the available fuel quality and cleanliness may not be sufficient. This will result in problems with the fuel system.

- Refuel only with clean fuel that meets the specified standards.



Note

Environmental hazard Improper handling of fuel is a danger to the environment.

- Do not allow fuel to enter the groundwater, the soil, or the sewage system.

- Switch off the engine.
- Open fuel tank filler cap. (📖 p. 29)
- Fill the fuel tank with fuel up to level **A**.

Guideline

Level A	35 mm (1.38 in)	
Total fuel tank capacity, approx.	8.5 l (2.25 US gal)	Super unleaded (ROZ 95) (📖 p. 36) (All EU models)
Total fuel tank capacity, approx.		Super unleaded, type C (ROZ 95/RON 95/PON 91) (📖 p. 36) (EXC-F BR)

- Close the fuel tank filler cap. (📖 p. 30)

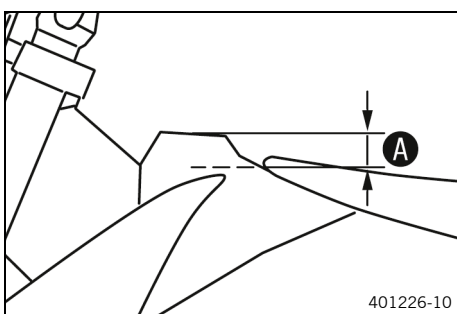

3.24 Setting kilometers or miles



Info

If you change the unit, the value **ODO** is retained and converted accordingly. The values **TR1**, **TR2**, **A1**, **A2** and **S1** are cleared when the unit of measure is changed.

Condition

The motorcycle is stationary.

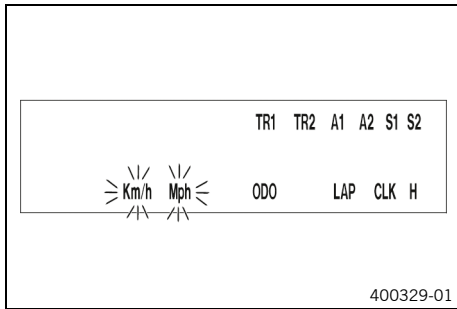

- Repeatedly press the button briefly until **H** appears at the bottom right of the display.
- Press the button for 2–3 seconds.
 - ✓ The Setup menu is displayed and the active functions are shown.
- Repeatedly press the button briefly until **Km/h/Mph** flashes.

Adjusting the Km/h

- Press the button .

Adjusting the Mph

- Press the button .
- Wait 3 - 5 seconds.
 - ✓ The settings are stored.

Info

If no button is pressed for 10–12 seconds, or if an impulse comes from the wheel speed sensor, the settings are automatically saved and the setup menu is closed.

3.25 Setting the combination instrument

Info

When the vehicle is delivered, only the **SPEED/H** and **SPEED/ODO** display modes are activated.

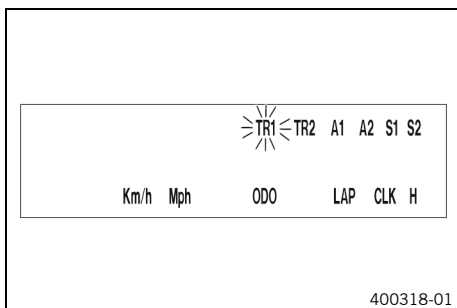

Condition

The motorcycle is stationary.

- Repeatedly press the button briefly until **H** appears at the bottom right of the display.
- Press the button for 2–3 seconds.
 - ✓ The Setup menu is displayed and the active functions are shown.

Info

If no button is pressed for 10–12 seconds, the settings are automatically saved.
If no button is pressed for 20 seconds, or if an impulse comes from the wheel speed sensor, the settings are automatically saved and the setup menu is closed.

- Repeatedly press the button briefly until the desired function flashes.
 - ✓ The selected function flashes.

Activating the function

- Press the button .
 - ✓ The symbol continues to appear in the display and the next function appears.

Deactivating a function





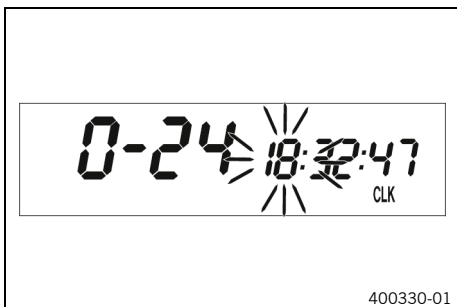

- Press the button .
 - ✓ The symbol disappears in the display and the next function appears.

3.26 Setting the clock



Condition

The motorcycle is stationary.

- Repeatedly press the button  briefly until **CLK** appears at the bottom right of the display.
- Press the button  for 2–3 seconds.
 - ✓ The hour display flashes.
- Adjust the hour display with the button  and/or button .
- Wait 3 - 5 seconds.
 - ✓ The next segment of the display flashes and can be set.
- You can set the following segments in the same way as the hours by pressing the button  and the button .



Info

The seconds can only be set to zero.

If no button is pressed for 15–20 seconds, or if an impulse comes from the wheel speed sensor, the settings are automatically saved and the setup menu is closed.



4 TECHNICAL SPECIFICATIONS

4.1 chassis tightening torques

Remaining screws, chassis	EJOT PT® K60x25-Z	2 Nm (1.5 lbf ft)
Screw, combination switch (EXC-F SIX DAYS)	EJOT PT® K50x18	2 Nm (1.5 lbf ft)
Screw, emergency OFF switch	EJOT PT® K50x18	2 Nm (1.5 lbf ft)
Screw, fuel pump	EJOT PT®	2.5 Nm (1.84 lbf ft)
Screw, intake air temperature sensor	EJOT DELTA PT® 45x12-Z	0.7 Nm (0.52 lbf ft)
Screw, pressure regulator	EJOT PT® K60x25-Z	2.3 Nm (1.7 lbf ft)
Screw, radiator hoses clip		2.4 Nm (1.77 lbf ft)
Screw, seat fixing	EJOT EJOFORM PT® K60x23/18	2.5 Nm (1.84 lbf ft)
Screw, fixed grip	M4	5 Nm (3.7 lbf ft) Loctite®243™
Screw, hose clip, throttle valve body	M4	5 Nm (3.7 lbf ft)
Spoke nipple, front wheel	M4.5	6 Nm (4.4 lbf ft)
Spoke nipple, rear wheel	M4.5	6 Nm (4.4 lbf ft)
Remaining nuts, chassis	M5	5 Nm (3.7 lbf ft)
Remaining screws, chassis	M5	5 Nm (3.7 lbf ft)
Screw, battery terminal	M5	2.5 Nm (1.84 lbf ft)
Screw, frame protector	M5	3 Nm (2.2 lbf ft)
Screw, light switch	M5	1 Nm (0.7 lbf ft)
Screw, throttle valve body cover	M5	2.6 Nm (1.92 lbf ft)
Screw, turn signal switch	M5	1 Nm (0.7 lbf ft)
Nut, starter motor	M6	4 Nm (3 lbf ft)
Nut, throttle cable on throttle valve body	M6	3 Nm (2.2 lbf ft)
Remaining nuts, chassis	M6	10 Nm (7.4 lbf ft)
Remaining screws, chassis	M6	10 Nm (7.4 lbf ft)
Screw, ball joint of push rod on rear brake cylinder	M6	10 Nm (7.4 lbf ft) Loctite®243™
Screw, battery holding bracket	M6	6 Nm (4.4 lbf ft)
Screw, brake line guide on link fork	M6	4.5 Nm (3.32 lbf ft)
Screw, chain sliding guard	M6	6 Nm (4.4 lbf ft) Loctite®243™
Screw, connector board with combination instrument	M6	5 Nm (3.7 lbf ft)
Screw, fender	M6	12 Nm (8.9 lbf ft)
Screw, front brake disc	M6	14 Nm (10.3 lbf ft) Loctite®243™
Screw, fuel tank spoiler on radiator	M6	6 Nm (4.4 lbf ft)
Screw, ground wire on frame	M6	10 Nm (7.4 lbf ft)
Screw, hand lever	M6	5 Nm (3.7 lbf ft)
Screw, rear brake disc	M6	14 Nm (10.3 lbf ft) Loctite®243™
Screw, seat fixing	M6	8 Nm (5.9 lbf ft)

Screw, starter cable to starter relay	M6	6 Nm (4.4 lbf ft)
Screw, throttle grip	M6	5 Nm (3.7 lbf ft)
Nut, rear sprocket screw	M8	35 Nm (25.8 lbf ft) Loctite®2701™
Nut, rim lock	M8	12 Nm (8.9 lbf ft)
Rear brake lever stop nut	M8	20 Nm (14.8 lbf ft)
Remaining nuts, chassis	M8	25 Nm (18.4 lbf ft)
Remaining screws, chassis	M8	25 Nm (18.4 lbf ft)
Screw, bottom triple clamp (EXC-F SIX DAYS)	M8	12 Nm (8.9 lbf ft)
Screw, bottom triple clamp (EXC-F EU/BR)	M8	15 Nm (11.1 lbf ft)
Screw, chain sliding piece	M8	15 Nm (11.1 lbf ft)
Screw, engine brace on engine	M8x20	25 Nm (18.4 lbf ft) Loctite®243™
Screw, engine brace on frame	M8x15	25 Nm (18.4 lbf ft) Loctite®2701™
Screw, fork stub	M8	15 Nm (11.1 lbf ft)
Screw, front brake caliper	M8	25 Nm (18.4 lbf ft) Loctite®243™
Screw, handlebar clamp	M8	20 Nm (14.8 lbf ft)
Screw, manifold	M8	15 Nm (11.1 lbf ft)
Screw, side stand attachment	M8	33 Nm (24.3 lbf ft) Loctite®2701™
Screw, subframe bottom	M8	30 Nm (22.1 lbf ft) Loctite®2701™
Screw, subframe top	M8	35 Nm (25.8 lbf ft) Loctite®2701™
Screw, top steering stem	M8	20 Nm (14.8 lbf ft)
Screw, top triple clamp (EXC-F SIX DAYS)	M8	17 Nm (12.5 lbf ft)
Screw, top triple clamp (EXC-F EU/BR)	M8	20 Nm (14.8 lbf ft)
Engine attachment bolt	M10	60 Nm (44.3 lbf ft)
Remaining nuts, chassis	M10	45 Nm (33.2 lbf ft)
Remaining screws, chassis	M10	45 Nm (33.2 lbf ft)
Screw, handlebar holder	M10	40 Nm (29.5 lbf ft) Loctite®243™
Screw, bottom shock absorber	M12	80 Nm (59 lbf ft) Loctite®2701™
Screw, top shock absorber	M12	80 Nm (59 lbf ft) Loctite®2701™
Nut, fork pivot	M16x1.5	100 Nm (73.8 lbf ft)
Screw, front wheel spindle	M20x1.5	35 Nm (25.8 lbf ft)
Screw, top steering head	M20x1.5	12 Nm (8.9 lbf ft)
Nut, wheel spindle, rear	M22	80 Nm (59 lbf ft)
Screw-in fitting, cooling system	M24x1.5	7.5 Nm (5.53 lbf ft) Loctite®243™

Super unleaded (ROZ 95)

Standard/classification

- DIN EN 228 (ROZ 95)

Guideline

- Only use super unleaded fuel that matches or is equivalent to the specified standard.
- Fuel with an ethanol content of up to 10% (E10 fuel) is safe to use.



Info

Do **not** use fuel containing methanol (e.g., M15, M85, M100) or more than 10% ethanol (e.g., E15, E25, E85, E100).

Super unleaded, type C (ROZ 95/RON 95/PON 91)

Standard/classification

- ANP (Agência Nacional do Petróleo) #57 (ROZ 95/RON 95/PON 91)

Guideline

- Only use super unleaded fuel that matches or is equivalent to the following specifications.
- Super unleaded fuel with an ethanol content of 19 to 27% is permissible.



Info

Do **not** use fuel made of methanol (e.g., M15, M85, M100).

Do **not** use fuel with less than 19% ethanol (e.g., E10).

Do **not** use fuel with more than 27% ethanol (e.g., E30, E85, E100).

Silicone spray

Recommended supplier

MOTOREX®

– Silicone Spray



3214915en

23.10.2023

