

150 EXC  
150 XC-W

ART. NO. 3214967EN





Perform the work described in these setup instructions before the vehicle is delivered to the customer.

Read the setup instructions in their entirety before beginning work.

These setup instructions were written to correspond to the latest state of this model series. We reserve the right to make modifications in the interest of technical advancement without at the same time updating these setup instructions.

We shall not provide a description of general workshop methods. Likewise, safety rules that apply in a workshop are not specified here. It is assumed that the work will be performed by a fully trained mechanic.

All specifications contained herein are non-binding. KTM Sportmotorcycle GmbH specifically reserves the right to modify or delete technical specifications, prices, colors, forms, materials, services, designs, equipment, etc., without prior notice and without specifying reasons, to adapt these to local conditions, as well as to stop production of a particular model without prior notice. KTM accepts no liability for delivery options, deviations from figures and descriptions, misprints, and other errors. The models portrayed partly contain special equipment that does not belong to the regular scope of supply.

© 2023 KTM Sportmotorcycle GmbH, Mattighofen Austria

All rights reserved

Reproduction, even in part, as well as copying of all kinds, is permitted only with the express written permission of the copyright owner.



ISO 9001(12 100 6061)

KTM applies quality assurance processes that lead to the highest possible product quality as defined in the ISO 9001 international quality management standard.

Issued by: TÜV Management Service

REG.NO. 12 100 6061

KTM Sportmotorcycle GmbH  
Stallhofnerstraße 3  
5230 Mattighofen, Austria

This document is valid for the following models:

150 EXC EU (F7103X6)

150 XC-W US (F7175X3)



# 1 MEANS OF REPRESENTATION

## 1.1 Symbols used

The meaning of specific symbols is described below.



Indicates an expected reaction (e.g. of a work step or a function).



Indicates an unexpected reaction (e.g. of a work step or a function).



Indicates a page reference (more information is provided on the specified page).



Indicates information with more details or tips.



Indicates the result of a testing step.



Indicates a voltage measurement.



Indicates a current measurement.



Indicates a resistance measurement.



Indicates the end of an activity including potential rework.

## 1.2 Formats used

The typographical formats used in this document are explained below.

**Proprietary name**

Indicates a proprietary name.

**Name®**

Indicates a protected name.

**Brand™**

Indicates a brand available on the open market.

**Underlined terms**

Refer to technical details of the vehicle or indicate technical terms, which are explained in the glossary.

## 2.1 Transport mode

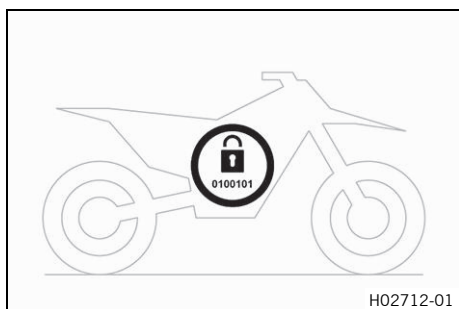

This vehicle was blocked for transport in the software. To operate the vehicle, the vehicle electronics must be enabled. This process is conducted during initial setup in KTM Dealer.net. Enabling ensures that the initial setup in KTM Dealer.net is documented.

Enabling can be performed either temporarily, e.g. for a test ride, or permanently for vehicle handover.

### **i** Info

Make sure that the vehicle is permanently enabled before handing it over to the customer.

## 2.2 Diagnostics connector

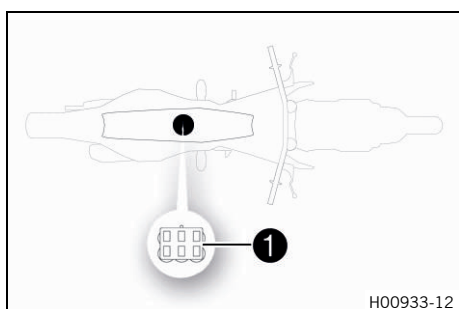

Diagnostics connector ① is located under the seat with the engine control unit.

## 2.3 Unpacking and setting up the vehicle

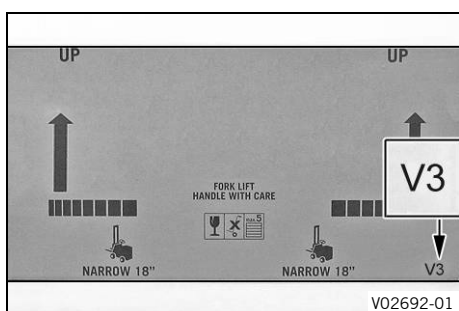

### Condition

#### Packaging V3

- Remove the box and the plastic packaging.

### **i** Info

To avoid damaging the motorcycle during the setup, leave the protective film on the vehicle until you have finished.

- Remove the separate enclosure and unpack it. Check that the scope of supply is complete on the basis of the enclosed packing list.

### **i** Info

The procedure for missing components is described in the Customer Service Manual.

- Carefully loosen and remove the tension belts around the fork legs.
- Remove the attachment on the rear wheel.

### **i** Info

An assistant prevents the motorcycle from falling over.

- Have a lift stand available.

Lift stand (A54029955100)

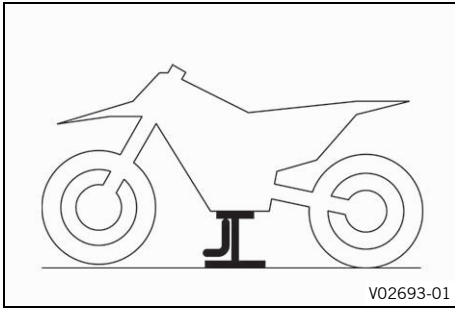

- Together with an assistant, take the vehicle off the pallet.
- Position the vehicle on a lift stand.
- Check the vehicle for transport damage.



### Info

The procedure in the event of transport damage is described in the Customer Service Manual.

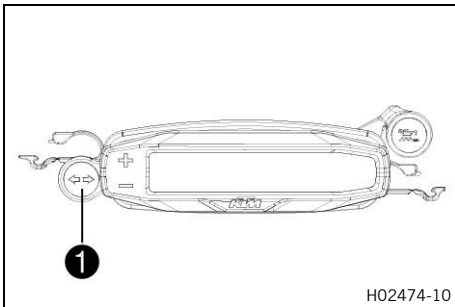

- Remove the headlight mask with the headlight. (📖 p. 26)
- Position the turn signal indicator lamp **1** in the combination instrument bracket.

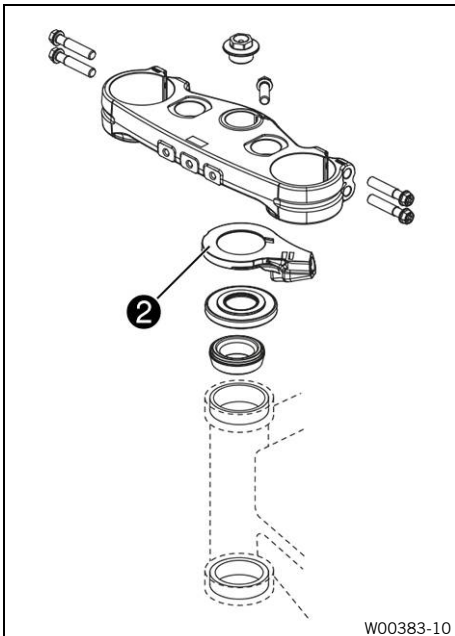

### (150 EXC EU)

- Loosen and lift upper triple clamp.
- Position steering lock **2**.
- Mount upper triple clamp on the ignition lock.

#### Guideline

|                          |    |                        |
|--------------------------|----|------------------------|
| Screw, top triple clamp  | M8 | 20 Nm<br>(14.8 lbf ft) |
| Screw, top steering stem | M8 | 20 Nm<br>(14.8 lbf ft) |

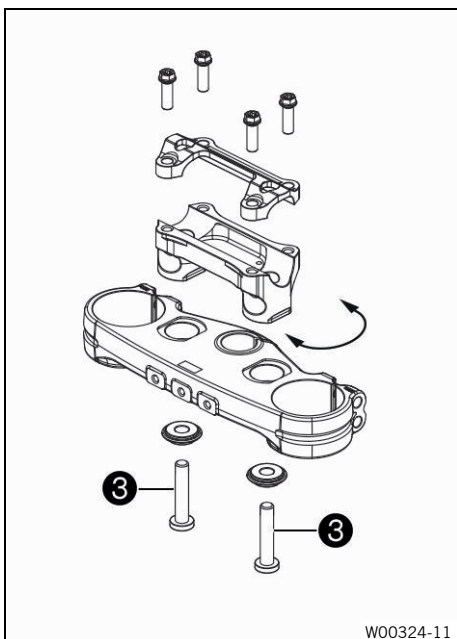

W00324-11

- Remove screws ③ and take off the handlebar support.
- Move the handlebar support in the desired position and mount and tighten screws ③.

Guideline

|                          |     |  |
|--------------------------|-----|--|
| Screw, handlebar support | M10 | 40 Nm (29.5 lbf ft)<br><b>Loctite®243™</b> |
|--------------------------|-----|--|

**i Info**  
Position the handlebar support so that it is even.

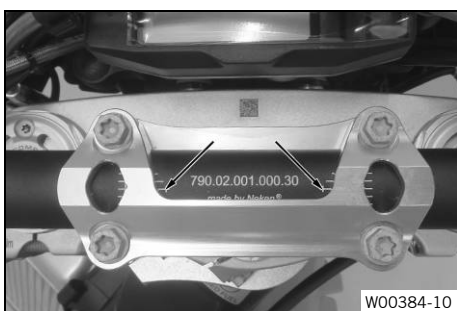

W00384-10

**! Warning**  
**Danger of accidents** A repaired handlebar poses a safety risk.  
If the handlebar is bent or straightened, the material becomes fatigued. The handlebar may break as a result.  
- Change the handlebar if the handlebar is damaged or bent.

- Position the handlebar.

**i Info**  
Make sure the cables and wiring are routed correctly.

- Position the handlebar clamps. Mount and tighten the screws evenly.

Guideline

|                        |    |                     |
|------------------------|----|---------------------|
| Screw, handlebar clamp | M8 | 20 Nm (14.8 lbf ft) |
|------------------------|----|---------------------|

**i Info**  
The markings on the handlebar should be at the center of the handlebar clamps.  
Keep the installed gap widths equal when tightening.



**(150 EXC EU)**

- Position the controls on the right half of the handlebar.



**(150 XC-W US)**

- Position the controls on the right half of the handlebar.



**(150 EXC EU)**

- Position the controls on the left handlebar half.



**(150 XC-W US)**

- Position the controls on the left handlebar half.



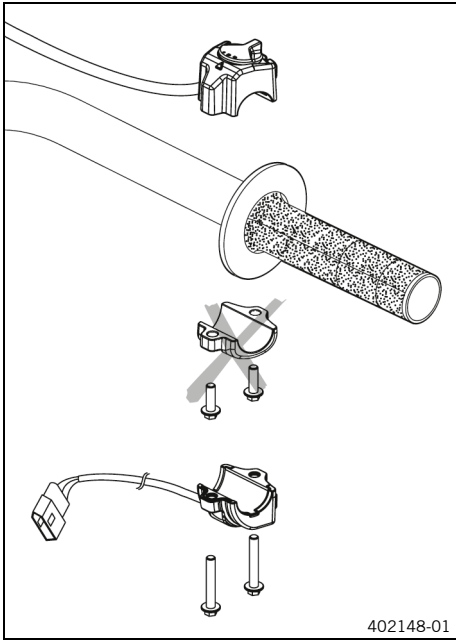

**(150 EXC EU)**

- Mount the turn signal switch.



- Join all plug-in connectors to the connector board.
- Route the cable without tension and secure with quick release.

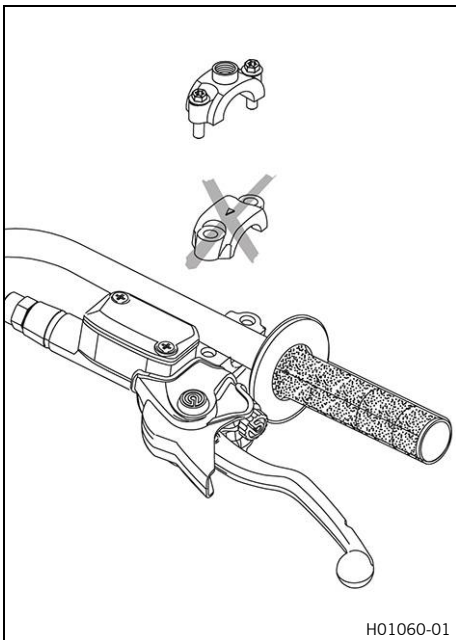

**(150 EXC EU)**

- Mount the mirror clamps on both sides.

## 2 SETUP

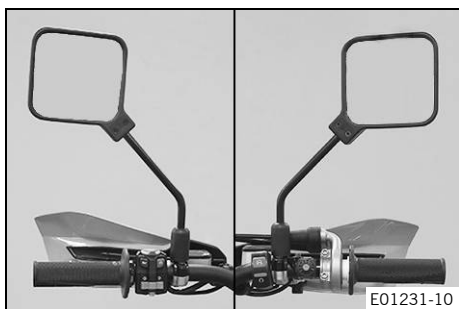

- Mount both rear mirrors with the adapter.



- Preassemble the hand guards on the left and right.



- Mount the left hand guard.
- Mount the right hand guard.





- Fix the handlebar cushion to the handlebar clamp.
- Install front fender. (📖 p. 26)
- Remove the 12-V battery. (📖 p. 22)
- Charge the 12-V battery. (📖 p. 23)

#### Guideline

The 12-V battery must be fully charged before it is handed over to the customer.

#### (150 XC-W US)

- Install the headlight mask with the headlight. (📖 p. 27)
- Install the 12-V battery. (📖 p. 24)
- Mount the seat. (📖 p. 17)

#### (150 EXC EU)

- Connect plug ④ with turn signal wiring harness.

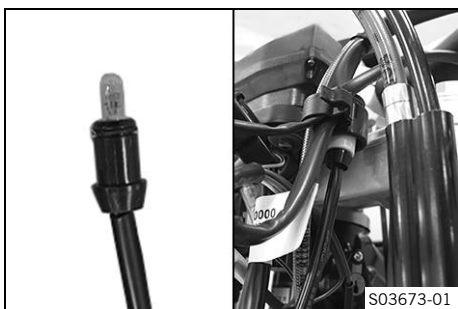
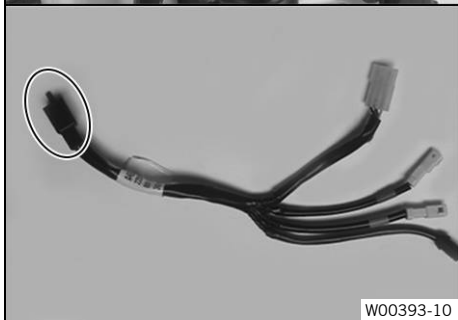

- Insert the black and violet cables of the bulb included in the separate enclosure into the socket and position it in the turn signal indicator lamp.

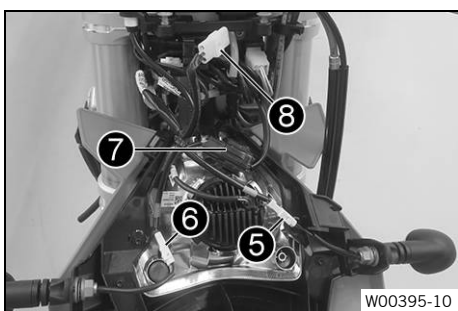

- Position the turn signal on the headlight mask on both sides, mount nuts with washers and tighten.
- Join plug-in connector ⑤ of the left turn signal using the violet and brown cable colors of the turn signal cable harness.
- Join plug-in connector ⑥ of the right turn signal using the black and brown cable colors of the turn signal cable harness.
- Join plug-in connector ⑦ of the headlight.
- Connect plug-in connector ⑧ of the turn signal switch.
- Install the headlight mask with the headlight. (📖 p. 27)

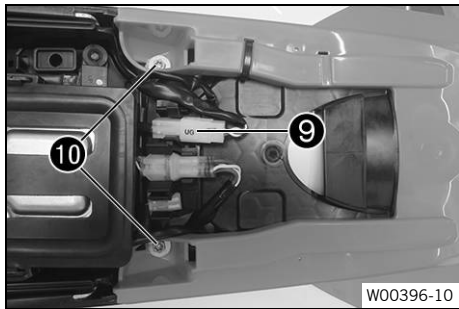

- Disconnect tail light plug-in connector **9** on the wiring harness.
- Remove screws **10**.

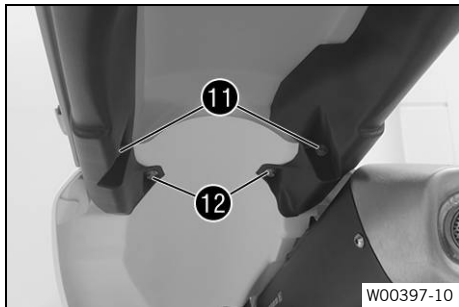

- Remove screws **11**.
- Remove screws **12**.
- Remove the license plate holder with the tail light.



### Info

Pay attention to the cable of the tail light.

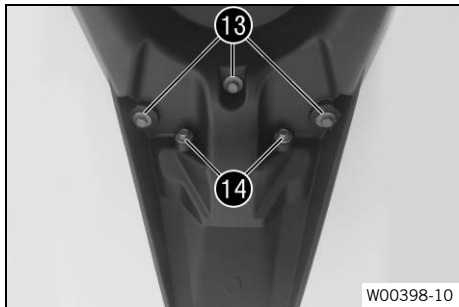

- Loosen screws **13** and remove license plate holder from fender.
- Loosen screws **14** and hang the tail light to the side.

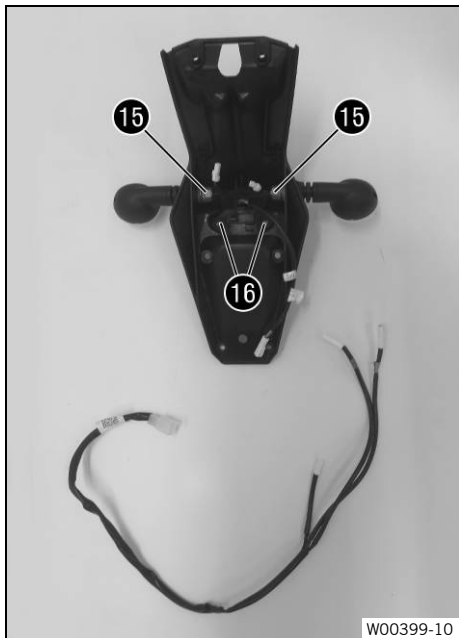

- Position the turn signal on both sides on the license plate holder, mount nuts **15** with washers and tighten.
- Position the license plate lamp on the license plate holder, and mount and tighten screws **16**.
- Connect the plug-in connections of the turn signals and the license plate lamp with the wiring harness.



- Drill a hole at marking **A** on the license plate holder to the size of the marking.

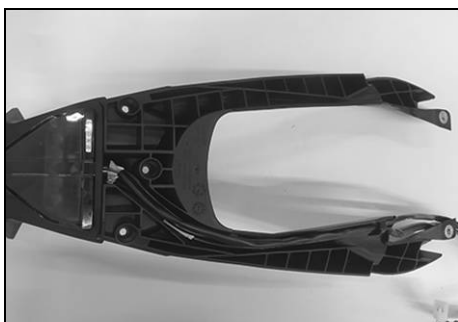

- Position the tail light together with the license plate holder on the license plate bracket.



**Info**

Ensure that the cables are routed correctly.

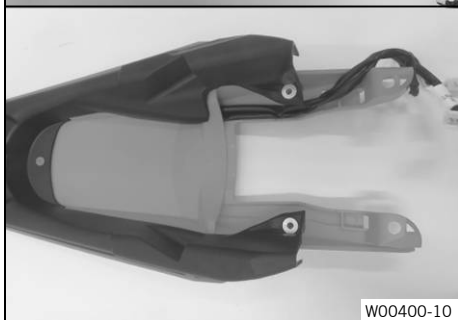

- Position the fender on the license plate holder.

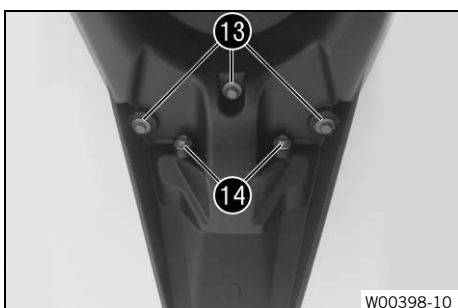

- Mount and tighten screws **14**.

Guideline

|                           |                             |                   |
|---------------------------|-----------------------------|-------------------|
| Remaining screws, chassis | <b>EJOT PT®</b><br>K60x25-Z | 2 Nm (1.5 lbf ft) |
|---------------------------|-----------------------------|-------------------|

- Mount and tighten screws **13**.

Guideline

|                           |                             |                   |
|---------------------------|-----------------------------|-------------------|
| Remaining screws, chassis | <b>EJOT PT®</b><br>K60x25-Z | 2 Nm (1.5 lbf ft) |
|---------------------------|-----------------------------|-------------------|

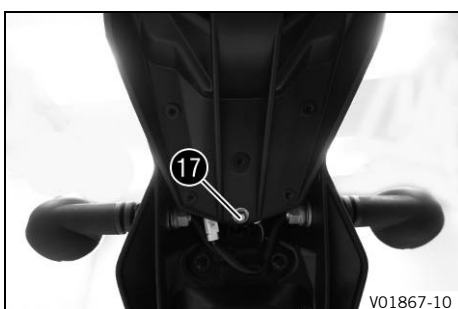

- Mount and tighten screw **17**.

Guideline

|                           |                             |                   |
|---------------------------|-----------------------------|-------------------|
| Remaining screws, chassis | <b>EJOT PT®</b><br>K60x25-Z | 2 Nm (1.5 lbf ft) |
|---------------------------|-----------------------------|-------------------|

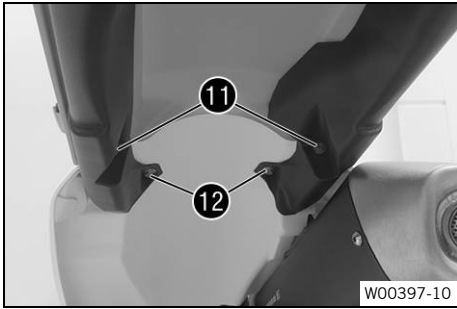

- Slide license plate holder onto tail section and position.

**i Info**  
Ensure that the cables are routed correctly.

- Mount and tighten screws **12**.

Guideline

|                           |    |                    |
|---------------------------|----|--------------------|
| Remaining screws, chassis | M6 | 10 Nm (7.4 lbf ft) |
|---------------------------|----|--------------------|

- Mount and tighten screws **11**.

Guideline

|                           |                             |                   |
|---------------------------|-----------------------------|-------------------|
| Remaining screws, chassis | <b>EJOT PT®</b><br>K60x25-Z | 2 Nm (1.5 lbf ft) |
|---------------------------|-----------------------------|-------------------|

- Mount and tighten screws **10**.

Guideline

|                           |    |                    |
|---------------------------|----|--------------------|
| Remaining screws, chassis | M6 | 10 Nm (7.4 lbf ft) |
|---------------------------|----|--------------------|

- Join the plug-in connectors of tail light **18** and turn signal cable harness **19** with the wiring harness.

**i Info**  
Pay attention to routing of the wiring harnesses.

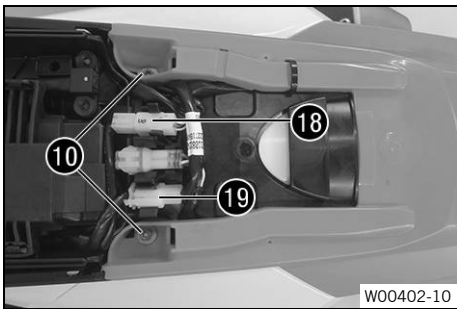

- Install the 12-V battery. (📖 p. 24)

- Mount the seat. (📖 p. 17)

- Position the right footrest and pin.

**i Info**  
Only insert the pin to the extent that the spring can still be mounted.

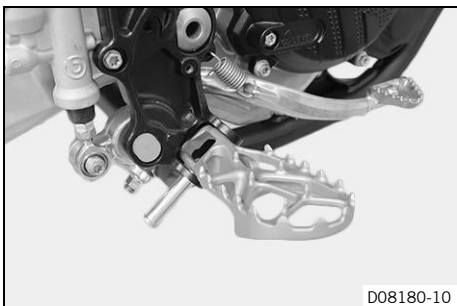

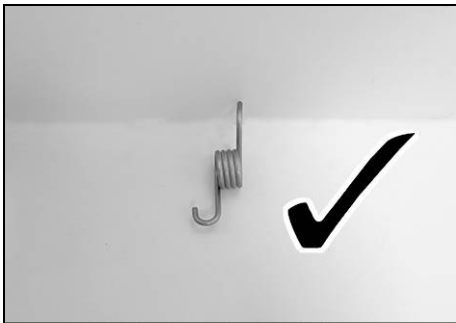

- Position spring as shown.
- ✓ Spring **B** engages in area **C**.

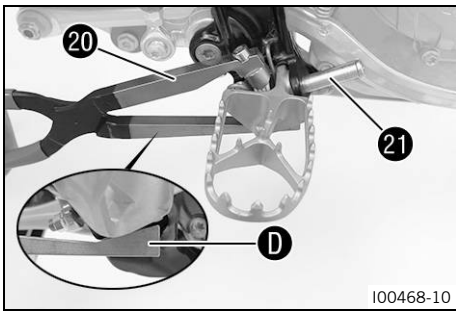
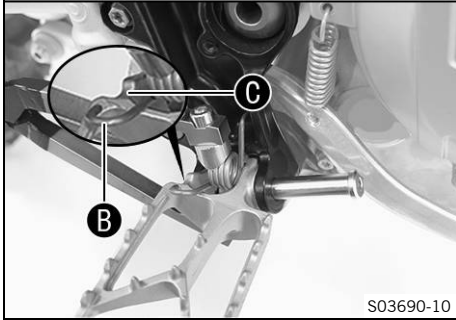

- Press the spring with special tool **20**.

Footrest spring plier (79029083000)

- ✓ The special tool is applied to area **D** on the footrest.
- Mount pin **21**.

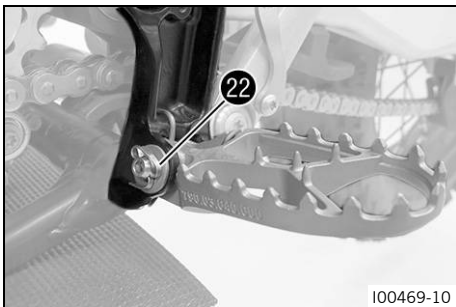

- Mount the washer and splint **22**.

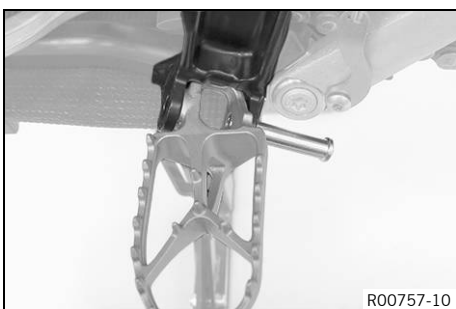

- Position the left footrest and pin.

---

**i Info**  
Only insert the pin to the extent that the spring can still be mounted.

---

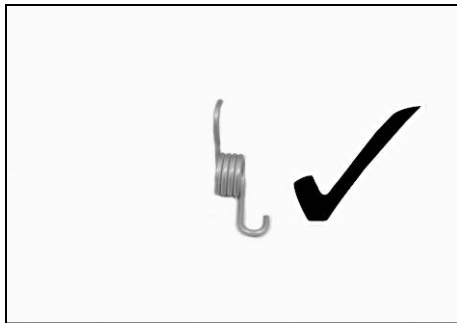

- Position spring as shown.  
✓ Spring **E** engages in area **F**.

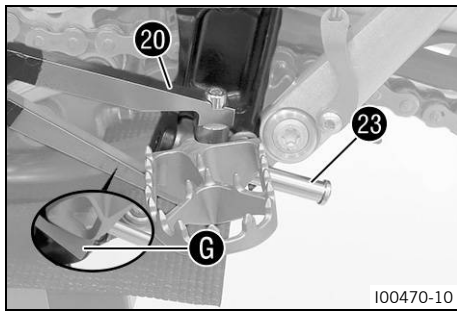
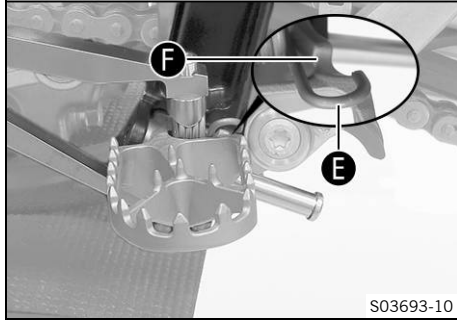

- Press the spring with special tool **20**.  
Footrest spring plier (79029083000)  
✓ The special tool is applied to area **G** on the footrest.
- Mount pin **23**.

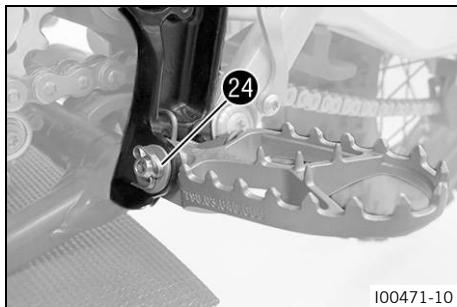

- Mount the washer and splint **24**.





I00472-10

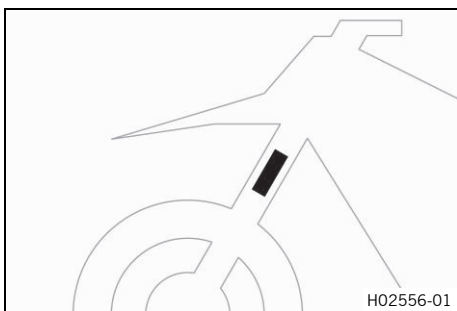

H02556-01

- Stick displacement sticker on the left and right of the side cover.
- Install the engine guard. (📖 p. 29)
- Install the frame protector. (📖 p. 29)
- Unpack and mount the **KTM PowerParts** included in the delivery (optional).

---

**i Info**  
Read the accompanying **KTM PowerParts** fitting instructions.

---

- Make sure that the reflectors are glued on to the left and right fork leg.

---

**i Info**  
The reflectors must not be covered by trim parts.

---

- Attach the stickers included in the scope of supply (optional).
- Charge the 12-V battery. (📖 p. 23)

**Guideline**

The 12-V battery must be fully charged before it is handed over to the customer.

---

**i Info**  
The first charging process may take longer with a new 12-V battery.

---

- Set kilometers or miles. (📖 p. 32)
- Adjust combination instrument function. (📖 p. 33)
- Set the clock. (📖 p. 33)
- Add 2-stroke oil. (📖 p. 30)
- Refuel. (📖 p. 31)
- Position all controls in their exact positions on the handlebar. Tighten all screws.
- Remove the remaining film, padding, the corrugated cardboard, and the other packaging material.
- Prepare the vehicle according to the specifications in **KTM Dealer.net** for handover to the customer.

---

**i Info**  
Transport mode must be deactivated to be able to start the motorcycle.

---



## 3.1 Raising the motorcycle with a lift stand

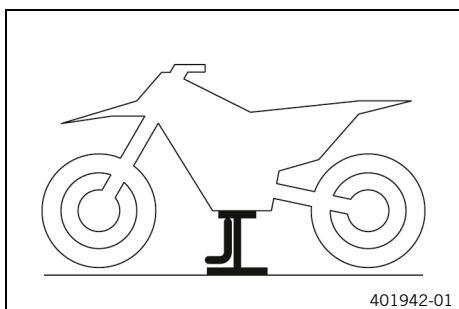

### Note

**Danger of damage** The parked vehicle can roll away or fall over.

- Park the vehicle on a firm and level surface.
- Raise the motorcycle at the frame underneath the engine.

Lift stand (78129955100)

- ✓ Neither wheel is in contact with the ground.
- Secure the motorcycle against falling over.

## 3.2 Removing the motorcycle from the lift stand

### Note

**Danger of damage** The parked vehicle can roll away or fall over.

- Park the vehicle on a firm and level surface.

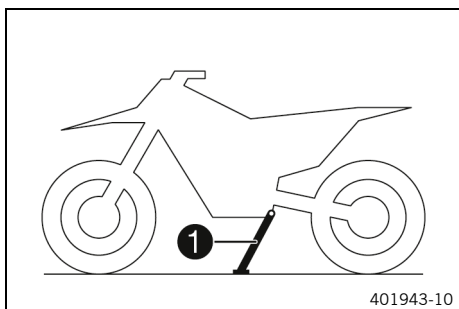

- Remove the motorcycle from the lift stand.
- Remove the lift stand.
- To park the motorcycle, press side stand **1** to the ground with your foot and lean the motorcycle on it.

### Info

When you are riding, the side stand must be folded up and secured with the rubber strap.

## 3.3 Removing the seat

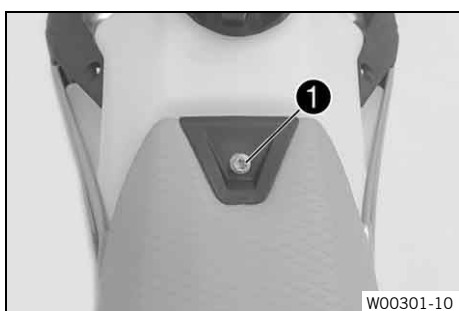

- Remove screw **1**.

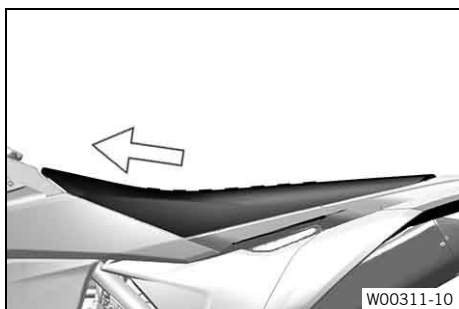

- Pull seat toward the fuel tank and lift it off.

### 3.4 Mounting the seat

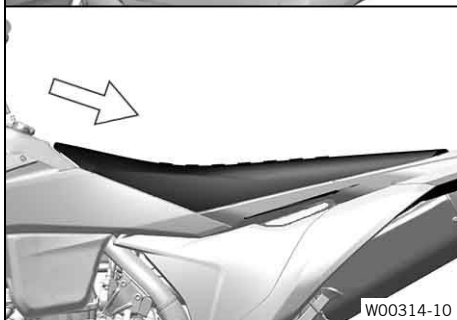
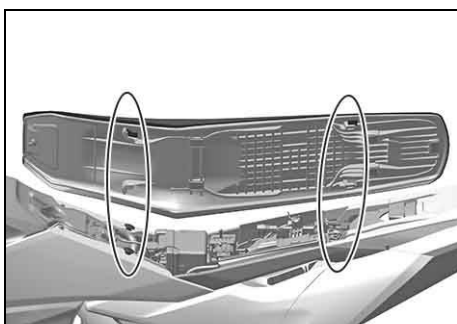

- Mount the front of the seat on the collar bushings of the fuel tank, lower the seat at the rear, and push the seat to the rear.
- ✓ The holding lugs engage in the recesses at the back.
- Make sure the seat is latched in place correctly.

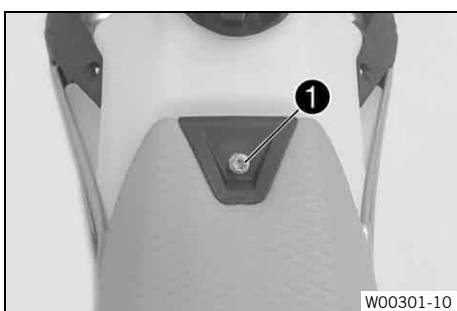

- Mount and tighten screw ①.

Guideline

|                    |    |                   |
|--------------------|----|-------------------|
| Screw, seat fixing | M6 | 8 Nm (5.9 lbf ft) |
|--------------------|----|-------------------|

### 3.5 Removing the fuel tank



**Danger**

**Fire hazard** Fuel is highly flammable.

The fuel in the fuel tank expands when warm and can escape if overfilled.

- Do not fuel the vehicle in the vicinity of open flames or lit cigarettes.
- Switch off the engine for refueling.
- Make sure that no fuel is spilled; particularly not on hot parts of the vehicle.
- If any fuel is spilled, wipe it off immediately.
- Observe the specifications for refueling.



## Warning

**Danger of poisoning** Fuel is harmful to health.

- Avoid skin, eye and clothing contact with fuel.
- Immediately consult a doctor if you swallow fuel.
- Do not inhale fuel vapors.
- Rinse the affected area immediately with plenty of water in the event of contact with the skin.
- Rinse the eyes thoroughly with water, and consult a doctor in case of fuel contact with the eyes.
- Change your clothing if fuel spills on them.
- Keep fuels correctly in a suitable canister, and out of the reach of children.

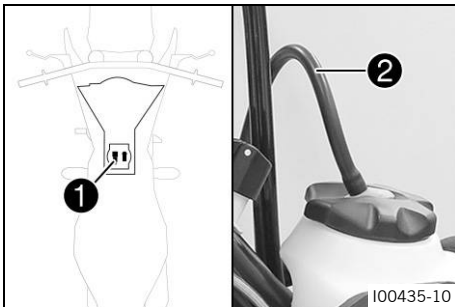

### Preparatory work

- Remove the seat. (📖 p. 16)

### Main work

- Unplug fuel pump connector **1**.
- Remove hose **2** from the fuel tank breather.

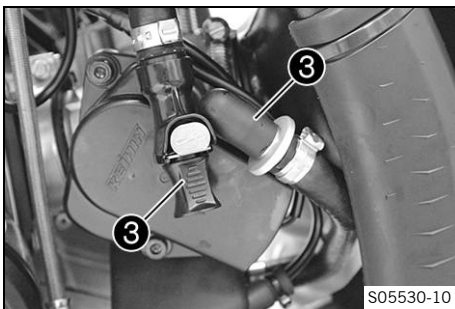

- Clean the quick release coupling thoroughly with compressed air.



#### Info

Under no circumstances should dirt enter into the fuel line. Dirt in the fuel line clogs the injection valve!

- Disconnect the quick release coupling.



#### Info

Remaining fuel may flow out of the fuel hose.

- Mount wash cap set **3**.

Wash cap set (81212016100)

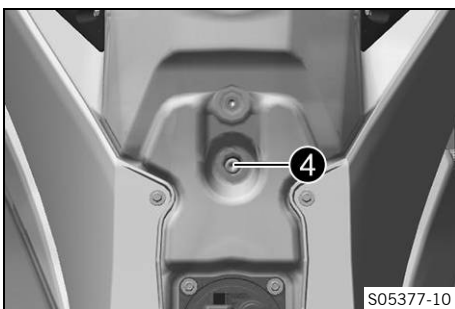

- Remove screw **4** with the rubber bushing.

### (150 EXC EU)

- Hang the horn and horn bracket to one side.

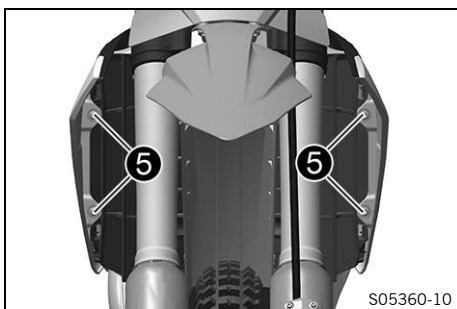

- Remove screws 5 with the collar bushings.

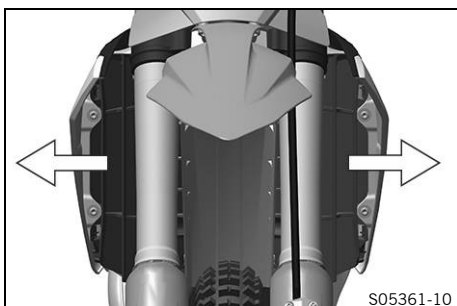

- Pull both spoilers off laterally from the radiator bracket and lift off the fuel tank.

### 3.6 Installing the fuel tank



#### Danger

**Fire hazard** Fuel is highly flammable.

The fuel in the fuel tank expands when warm and can escape if overfilled.

- Do not fuel the vehicle in the vicinity of open flames or lit cigarettes.
- Switch off the engine for refueling.
- Make sure that no fuel is spilled; particularly not on hot parts of the vehicle.
- If any fuel is spilled, wipe it off immediately.
- Observe the specifications for refueling.



#### Warning

**Danger of poisoning** Fuel is harmful to health.

- Avoid skin, eye and clothing contact with fuel.
- Immediately consult a doctor if you swallow fuel.
- Do not inhale fuel vapors.
- Rinse the affected area immediately with plenty of water in the event of contact with the skin.
- Rinse the eyes thoroughly with water, and consult a doctor in case of fuel contact with the eyes.
- Change your clothing if fuel spills on them.

#### Main work

- Check the throttle cable routing. (📖 p. 21)

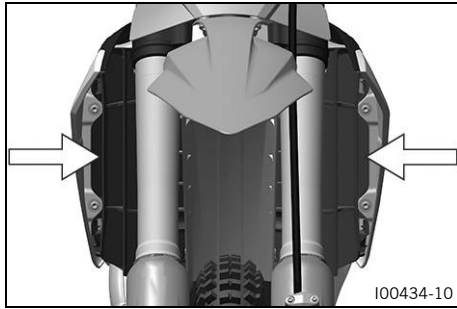

- Position the fuel tank and fit the two spoilers to the sides in front of the radiator bracket.
- Make sure that no cables or throttle cables are trapped or damaged.

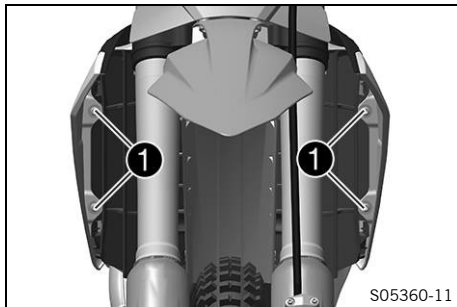

- Mount and tighten screw **1** with the rubber bushing.

Guideline

|                           |    |                    |
|---------------------------|----|--------------------|
| Remaining screws, chassis | M6 | 10 Nm (7.4 lbf ft) |
|---------------------------|----|--------------------|

**(150 EXC EU)**

- Position the horn with the horn bracket.

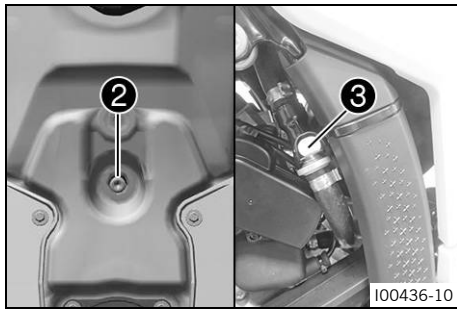

- Mount and tighten screws **2** with the collar bushings.

Guideline

|                                      |    |                   |
|--------------------------------------|----|-------------------|
| Screw, fuel tank spoiler on radiator | M6 | 6 Nm (4.4 lbf ft) |
|--------------------------------------|----|-------------------|

- Remove the wash cap set.
- Clean the quick release coupling thoroughly with compressed air.



**Info**

Under no circumstances should dirt enter into the fuel line. Dirt in the fuel line clogs the injection valve!

- Clean the quick release coupling thoroughly with compressed air.



**Info**

Under no circumstances should dirt enter into the fuel line. Dirt in the fuel line clogs the injection valve!

- Lubricate the O-ring and join quick release coupling **3**.



**Info**

Route the cable and fuel line at a safe distance from the exhaust system.

- Spray silicone spray onto a lint-free cleaning cloth and lightly lubricate the O-ring of the quick-release coupling.

|                          |
|--------------------------|
| Silicone spray (📖 p. 38) |
|--------------------------|

- Join quick release coupling **3**.

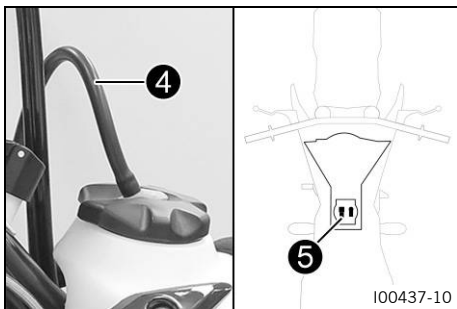

- Attach fuel tank breather hose ④.
- Plug in fuel pump connector ⑤.

**Finishing work**

- Mount the seat. (🔧 p. 17)

**3.7 Checking the throttle cable routing**



**Warning**

**Danger of accidents** The throttle cable can become kinked, trapped or blocked if it is not routed correctly.

If the throttle cable is kinked, trapped or blocked, the speed can no longer be controlled.

- Make sure that the throttle cable routing and the play in throttle cable complies with the specification.

**Preparatory work**

- Remove the seat. (🔧 p. 16)
- Remove the fuel tank. (🔧 p. 17)

**Main work**

- Check the throttle cable routing.

Both throttle cables must be routed, side by side, on the back of the handlebars, above the fuel tank roller on the right of the frame to the throttle valve body. Both throttle cables must be secured behind the rubber strap of the fuel tank support.

- » If the throttle cable routing is not as specified:
  - Correct the throttle cable routing.

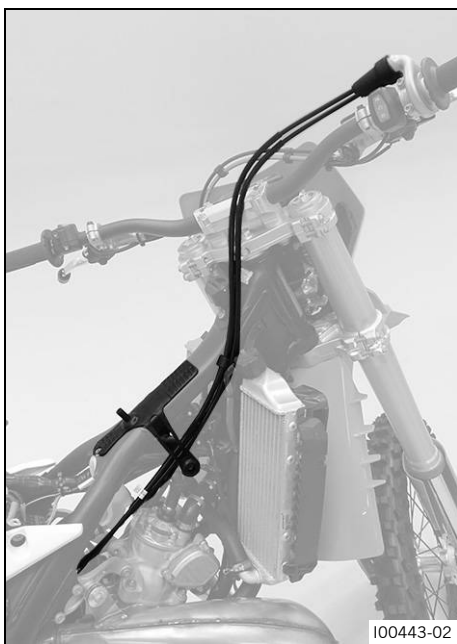

**Finishing work**

- Install the fuel tank. (🔧 p. 19)
- Mount the seat. (🔧 p. 17)

## 3.8 Removing the 12-V battery



### Note

**Environmental hazard** 12 V batteries contain environmentally hazardous materials.

- Do not dispose of 12 V batteries as household waste.
- Dispose of 12 V batteries at a collection point for used batteries.



### Note

**Environmental hazard** Hazardous substances cause environmental damage.

- Dispose of oils, grease, filters, fuel, cleaning agents, brake fluid, etc., correctly and in compliance with the applicable regulations.

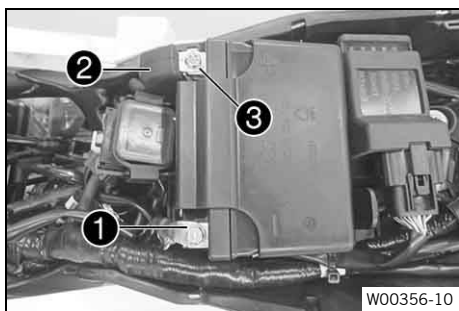

### Preparatory work

- Remove the seat. (📖 p. 16)
- Remove the fuel tank. (📖 p. 17)

### Main work



### Warning

**Risk of injury** 12 V batteries contain harmful substances.

- Keep 12 V batteries out of the reach of children.
- Keep sparks and open flames away from 12 V batteries.
- Only charge 12 V batteries in well-ventilated rooms.
- Maintain a minimum clearance from inflammable materials when charging 12 V batteries.  
Minimum clearance 1 m (3 ft)
- Do not charge deeply discharged 12 V batteries if the charge is already below the minimum voltage.  
Minimum voltage before 9 V the start of the charge
- Dispose of 12 V batteries correctly if they have less than the minimum voltage.

- Disconnect negative cable ① from the 12-V battery.
- Pull back positive terminal cover ② and disconnect positive cable ③ from the 12-V battery.
- Remove screw ④.





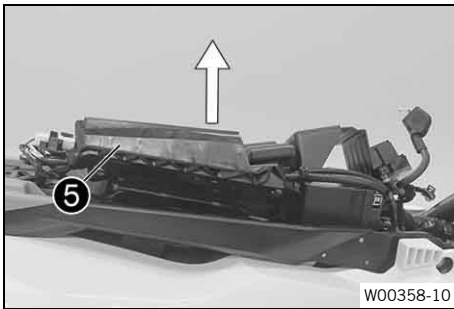

- Pull up battery holding bracket ⑤ and remove the 12-V battery to the rear.

**i Info**  
Pay attention to the wiring harness.

### 3.9 Charging the 12-V battery



**Warning**

**Risk of injury** 12 V batteries contain harmful substances.

- Keep 12 V batteries out of the reach of children.
- Keep sparks and open flames away from 12 V batteries.
- Only charge 12 V batteries in well-ventilated rooms.
- Maintain a minimum clearance from inflammable materials when charging 12 V batteries.  
Minimum clearance 1 m (3 ft)
- Do not charge deeply discharged 12 V batteries if the charge is already below the minimum voltage.  
Minimum voltage before the start of the charge 9 V
- Dispose of 12 V batteries correctly if they have less than the minimum voltage.

**Note**

**Danger of damage** An incorrectly selected charging mode will damage the 12-V battery.

- Always select a charging mode that is compatible with the type of battery.



**Note**

**Environmental hazard** 12 V batteries contain environmentally hazardous materials.

- Do not dispose of 12 V batteries as household waste.
- Dispose of 12 V batteries at a collection point for used batteries.



**Note**

**Environmental hazard** Hazardous substances cause environmental damage.

- Dispose of oils, grease, filters, fuel, cleaning agents, brake fluid, etc., correctly and in compliance with the applicable regulations.



**Info**

Even when there is no load on the 12-V battery, it discharges steadily each day. The charging level and the method of charging are very important for the service life of the 12-V battery. Rapid recharging with a high charging current shortens the service life of the battery. If the charging current, charging voltage, or charging time is exceeded, the 12-V battery will be destroyed. If the 12-V battery is depleted by repeated starting, the 12-V battery must be charged immediately. If the 12-V battery is left in a discharged state for an extended period, it will become deeply discharged and suffer a loss of capacity, destroying the battery. The 12-V battery is maintenance-free.

**Preparatory work**

- Remove the seat. (📖 p. 16)
- Disconnect the negative cable of the 12-V battery. (📖 p. 25)

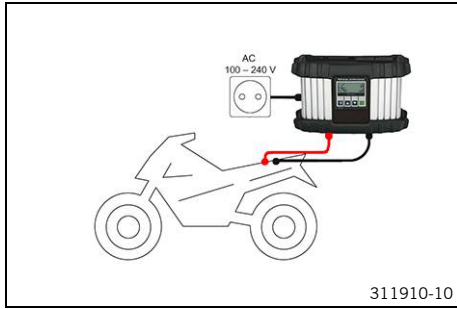

### Main work

- Connect a battery charger to the 12-V battery. Adjust the battery charger.

EU battery charger **XCharge-professional** (00029095050)

### Alternative 1

US battery charger **XCharge-professional** (00029095051)

### Alternative 2

UK battery charger **XCharge-professional** (00029095052)



### Info

Follow the instructions of the charger and the manual.

- Disconnect the battery charger after charging the 12-V battery.

### Guideline

The charging current, charging voltage, and charging time must not be exceeded.

Recharge the 12-V battery regularly when the motorcycle is not being used

3 months

### Finishing work

- Connect the negative cable of the 12-V battery. (🔧 p. 25)
- Mount the seat. (🔧 p. 17)

## 3.10 Installing the 12-V battery

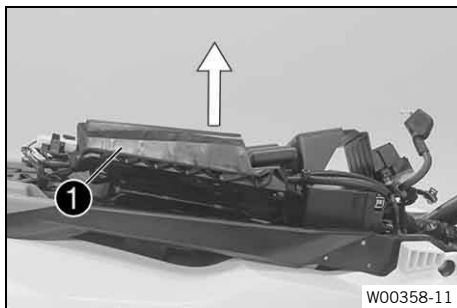

### Main work

- Pull up battery holding bracket **1**, insert the 12-V battery into the battery compartment with the terminals facing upward and secure with battery holding bracket **1**.

12-V battery (HJTZ5S-FP-C)



### Info

Ensure that the cable is routed correctly.

- Mount and tighten screw **2**.

### Guideline

Screw, battery support bracket

M6

6 Nm (4.4 lbf ft)

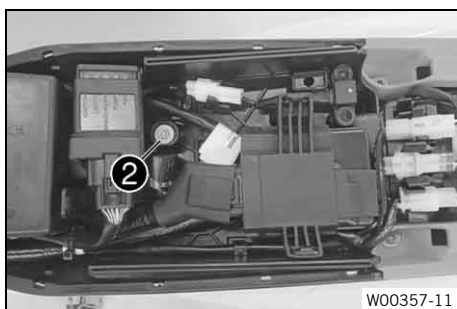

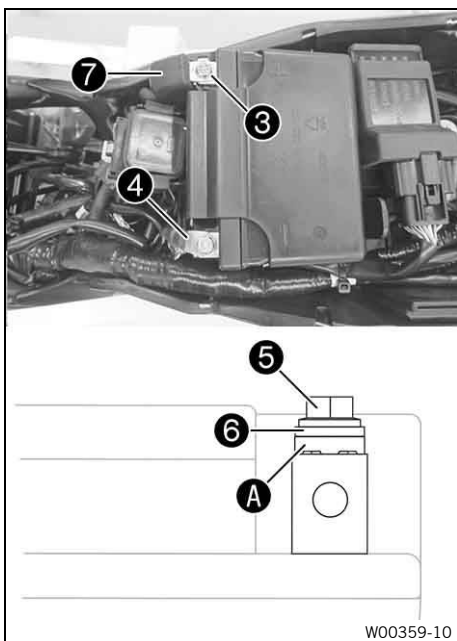

- Connect positive cable ③ to the 12-V battery.

Guideline

|                         |    |                         |
|-------------------------|----|-------------------------|
| Screw, battery terminal | M5 | 2.5 Nm<br>(1.84 lbf ft) |
|-------------------------|----|-------------------------|

- Connect negative cable ④ to the 12 V battery.

Guideline

|                         |    |                         |
|-------------------------|----|-------------------------|
| Screw, battery terminal | M5 | 2.5 Nm<br>(1.84 lbf ft) |
|-------------------------|----|-------------------------|

Contact disks A must be mounted under screws ⑤ and cable sockets ⑥ with the claws toward the battery terminal.

- Slide positive terminal cover ⑦ over the positive terminal.

**Finishing work**

- Install the fuel tank. (📖 p. 19)
- Mount the seat. (📖 p. 17)

**3.11 Disconnecting the negative cable of the 12-V battery**

**Preparatory work**

- Remove the seat. (📖 p. 16)

**Main work**

- Disconnect negative cable ① of the 12-V battery.

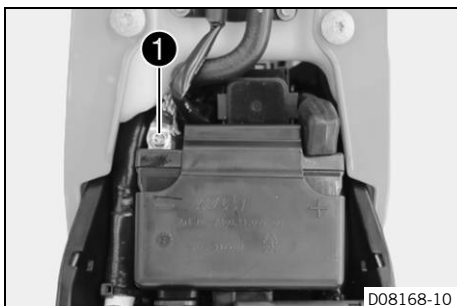

**3.12 Connecting the negative cable of the 12-V battery**

**Main work**

- Connect negative cable ① of the 12-V battery.

Guideline

|                         |    |                         |
|-------------------------|----|-------------------------|
| Screw, battery terminal | M5 | 2.5 Nm<br>(1.84 lbf ft) |
|-------------------------|----|-------------------------|

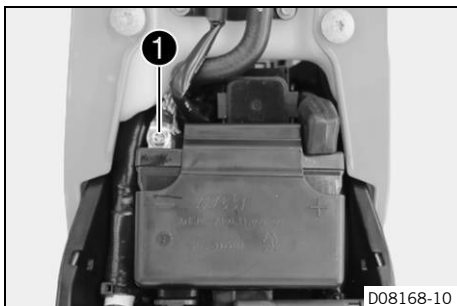

**Finishing work**

- Mount the seat. (📖 p. 17)

## 3.13 Installing front fender

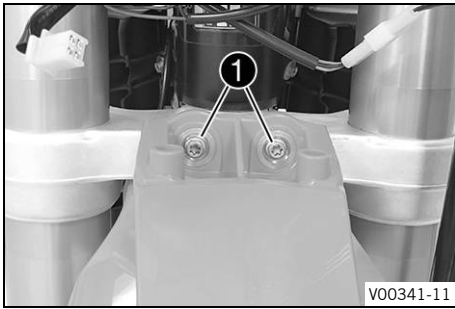

### Main work

- Position front fender. Mount and tighten screws ①.

### Guideline

|                           |    |                    |
|---------------------------|----|--------------------|
| Remaining screws, chassis | M6 | 10 Nm (7.4 lbf ft) |
|---------------------------|----|--------------------|

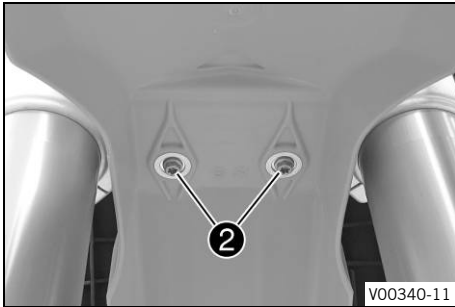

- Mount and tighten screws ②.

### Guideline

|                           |    |                    |
|---------------------------|----|--------------------|
| Remaining screws, chassis | M6 | 10 Nm (7.4 lbf ft) |
|---------------------------|----|--------------------|

### Finishing work

- Install the headlight mask with the headlight. (📖 p. 27)
- Check the headlight setting. (📖 p. 28)

## 3.14 Removing the headlight mask with the headlight



- Release screws ①.
- Slide the headlight mask up and swing it forward.
- Disconnect the brake line at the headlight mask.

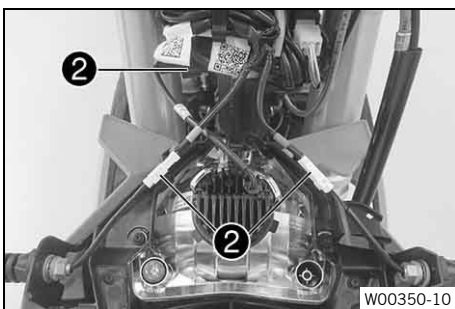

### (150 EXC EU)

- Detach plug-in connectors ② and take off the headlight mask with the headlight.

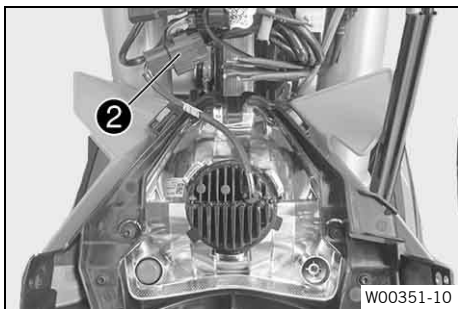

(150 XC-W US)

- Disconnect plug-in connector **2** and take off the headlight mask together with the headlight.

**3.15 Installing the headlight mask with the headlight**

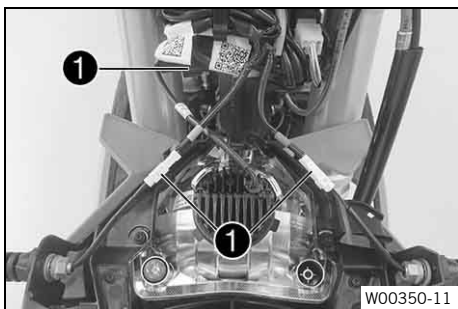

**Main work**

(150 EXC EU)

- Join plug-in connectors **1**.

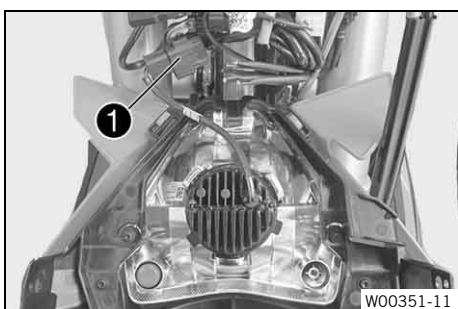

(150 XC-W US)

- Join plug-in connector **1**.

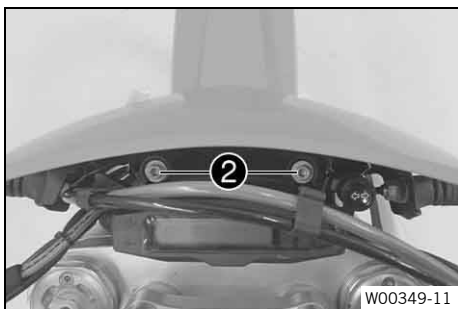

- Position the brake line in the brake line guide.
- Position the headlight mask.
- ✓ The holding lugs engage in the fender.
- Mount and tighten screws **2**.

Guideline

|                           |    |                    |
|---------------------------|----|--------------------|
| Remaining screws, chassis | M6 | 10 Nm (7.4 lbf ft) |
|---------------------------|----|--------------------|

**Finishing work**

- Check the headlight setting. (📖 p. 28)

## 3.16 Checking the headlight setting

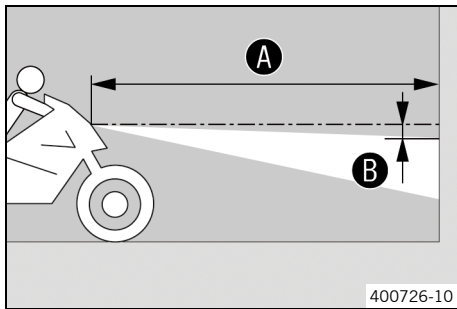

- Park the vehicle on a horizontal surface in front of a light-colored wall and make a mark at the height of the center of the low beam headlight.
- Make another mark at a distance **B** under the first marking.

Guideline

|                   |             |
|-------------------|-------------|
| Distance <b>B</b> | 5 cm (2 in) |
|-------------------|-------------|

- Position the vehicle vertically at a distance **A** away from the wall.

Guideline

|                   |             |
|-------------------|-------------|
| Distance <b>A</b> | 5 m (16 ft) |
|-------------------|-------------|

- The rider now sits down on the motorcycle.
- Switch on the low beam.
- Check the headlight setting.

The boundary between light and dark must be exactly on the lower mark for a motorcycle with rider.

- » If the boundary between light and dark does not meet specifications:
  - Adjust the headlight range. (📖 p. 28)

## 3.17 Adjusting the headlight range

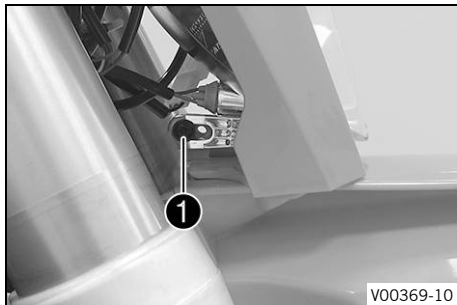

### Preparatory work

- Check the headlight setting. (📖 p. 28)

### Main work

- Loosen screw **1**.
- Adjust the headlight range by pivoting the headlight.

Guideline

The boundary between light and dark must be exactly on the lower mark for a motorcycle with rider (instructions on how to apply the mark: Checking the headlight setting).

### Info

If you have a payload, you may have to correct the headlight range.

- Tighten screw **1**.

### 3.18 Installing the engine guard

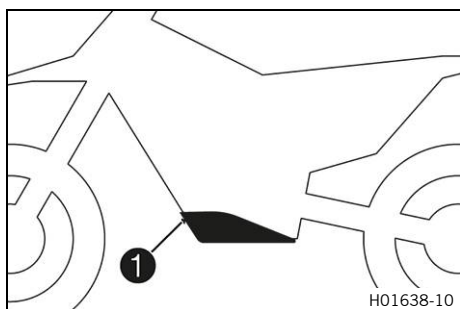

- Attach the engine guard on the frame at the rear and swing up at the front.
- Mount and tighten screws ①.

Guideline

|                           |    |                    |
|---------------------------|----|--------------------|
| Remaining screws, chassis | M6 | 10 Nm (7.4 lbf ft) |
|---------------------------|----|--------------------|



### 3.19 Installing the frame protector

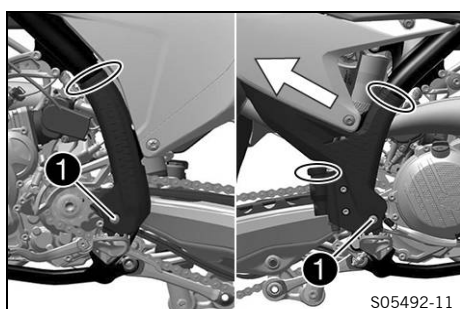

- Position the left frame protector.
- Insert the right frame protector from below and push it to the rear.
- Mount screws ① with the bushings and tighten.

Guideline

|                        |    |                   |
|------------------------|----|-------------------|
| Screw, frame protector | M5 | 3 Nm (2.2 lbf ft) |
|------------------------|----|-------------------|

- Secure the frame protector with cable ties.



### 3.20 Opening 2-stroke oil tank cap

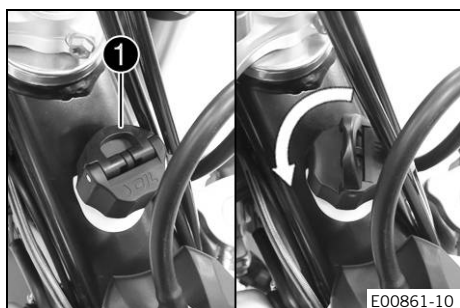

- Fold loop ① upward.
- Turn the 2-stroke oil tank cap counterclockwise and pull it up.



### 3.21 Closing 2-stroke oil tank cap

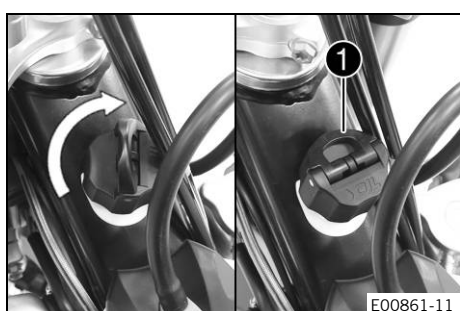

- Put the 2-stroke oil tank cap on and turn it clockwise.
- Fold loop ① down.
- ✓ The 2-stroke oil tank cap engages.



## 3.22 Adding 2-stroke oil



### Warning

**Engine failure** The engine will not be lubricated unless there is 2-stroke oil in the oil tank.

If the oil level warning light lights up, the 2-stroke oil is sufficient for the remaining tank of fuel.

- As soon as the oil level warning light lights up, ride for no longer than until the remaining fuel in the tank is depleted.
- At the next opportunity add 2-stroke oil before you refuel.
- Time the oil pump if the 2-stroke oil hose has been removed or the 2-stroke oil tank has been fully depleted in error.

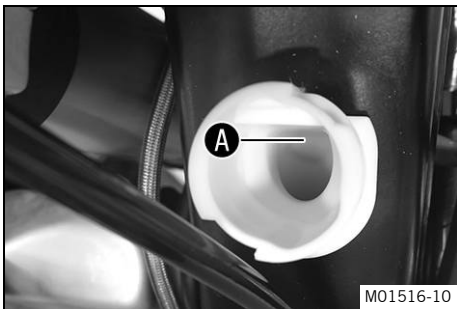

- Open 2-stroke oil tank cap. (📖 p. 29)
- Fill the 2-stroke oil tank up to the lower edge **A** of the filler neck.

### Guideline

Only use 2-stroke oil which is appropriate for separate lubrication.

|                                   |                 |                                |
|-----------------------------------|-----------------|--------------------------------|
| 2-stroke oil tank content approx. | 0.6 l (0.6 qt.) | Engine oil, 2-stroke (📖 p. 37) |
|-----------------------------------|-----------------|--------------------------------|

- Close 2-stroke oil tank cap. (📖 p. 29)

## 3.23 Opening the fuel tank filler cap



### Danger

**Fire hazard** Fuel is highly flammable.

The fuel in the fuel tank expands when warm and can escape if overfilled.

- Do not fuel the vehicle in the vicinity of open flames or lit cigarettes.
- Switch off the engine for refueling.
- Make sure that no fuel is spilled; particularly not on hot parts of the vehicle.
- If any fuel is spilled, wipe it off immediately.
- Observe the specifications for refueling.



### Warning

**Danger of poisoning** Fuel is harmful to health.

- Avoid skin, eye and clothing contact with fuel.
- Immediately consult a doctor if you swallow fuel.
- Do not inhale fuel vapors.
- Rinse the affected area immediately with plenty of water in the event of contact with the skin.
- Rinse the eyes thoroughly with water, and consult a doctor in case of fuel contact with the eyes.
- Change your clothing if fuel spills on them.
- Keep fuels correctly in a suitable canister, and out of the reach of children.



### Note

**Environmental hazard** Improper handling of fuel is a danger to the environment.

- Do not allow fuel to enter the groundwater, the soil, or the sewage system.



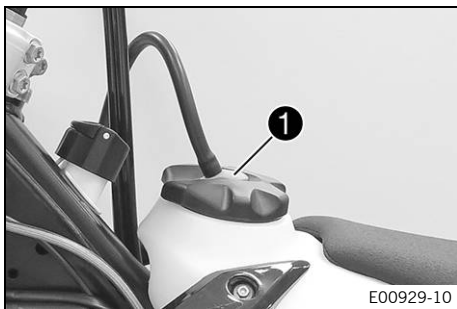

- Press release button ①, turn the fuel tank filler cap counter-clockwise, and lift it off.

### 3.24 Closing the fuel tank filler cap

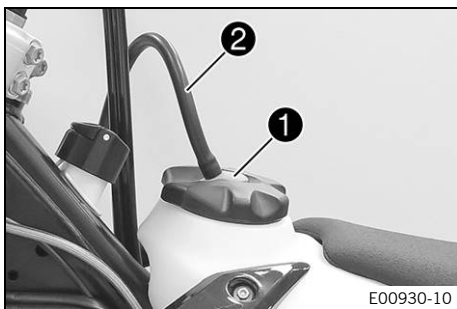

- Mount the fuel tank filler cap and turn it clockwise until release button ① engages.

**i Info**  
Route fuel tank breather hose ② without kinks.

### 3.25 Refueling



**Danger**

**Fire hazard** Fuel is highly flammable.

The fuel in the fuel tank expands when warm and can escape if overfilled.

- Do not fuel the vehicle in the vicinity of open flames or lit cigarettes.
- Switch off the engine for refueling.
- Make sure that no fuel is spilled; particularly not on hot parts of the vehicle.
- If any fuel is spilled, wipe it off immediately.
- Observe the specifications for refueling.



**Warning**

**Danger of poisoning** Fuel is harmful to health.

- Avoid skin, eye and clothing contact with fuel.
- Immediately consult a doctor if you swallow fuel.
- Do not inhale fuel vapors.
- Rinse the affected area immediately with plenty of water in the event of contact with the skin.
- Rinse the eyes thoroughly with water, and consult a doctor in case of fuel contact with the eyes.
- Change your clothing if fuel spills on them.

**Note**

**Material damage** Inadequate fuel quality causes the fuel filter to quickly become clogged.

In some countries and regions, the available fuel quality and cleanliness may not be sufficient. This will result in problems with the fuel system.

- Refuel only with clean fuel that meets the specified standards.



## Note

**Environmental hazard** Improper handling of fuel is a danger to the environment.

- Do not allow fuel to enter the groundwater, the soil, or the sewage system.

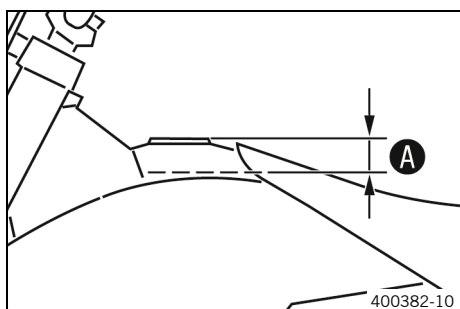

- Open the fuel tank filler cap. (🗨 p. 30)
- Fill the fuel tank with fuel up to level **A**.

Guideline

|                                   |                  |                                   |
|-----------------------------------|------------------|-----------------------------------|
| Level <b>A</b>                    | 35 mm (1.38 in)  |                                   |
| Total fuel tank capacity, approx. | 9 l (2.4 US gal) | Super unleaded (ROZ 95) (🗨 p. 37) |



## Info

Do not refuel using pre-mixed fuel.

- Close the fuel tank filler cap. (🗨 p. 31)

## 3.26 Setting kilometers or miles



## Info

If you change the unit, the value **ODO** is retained and converted accordingly.

The values **TR1**, **TR2**, **A1**, **A2** and **S1** are cleared when the unit of measure is changed.

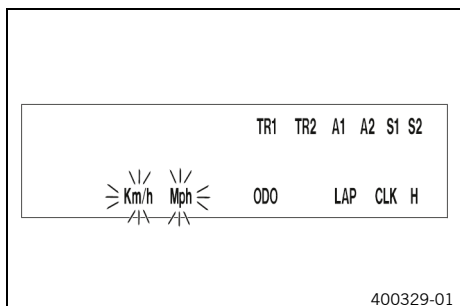

## Condition

The motorcycle is stationary.

- Repeatedly press the button **+** briefly until **H** appears at the bottom right of the display.
- Press the button **+** for 2–3 seconds.
  - ✓ The Setup menu is displayed and the active functions are shown.
- Repeatedly press the button **+** briefly until **Km/h/Mph** flashes.

## Adjusting the Km/h

- Press the button **+**.

## Adjusting the Mph

- Press the button **-**.
- Wait 3 - 5 seconds.
  - ✓ The settings are stored.



## Info

If no button is pressed for 10–12 seconds, or if an impulse comes from the wheel speed sensor, the settings are automatically saved and the setup menu is closed.

### 3.27 Adjusting combination instrument function

**i** **Info**

When the vehicle is delivered, only the **SPEED/H** and **SPEED/ODO** display modes are activated.

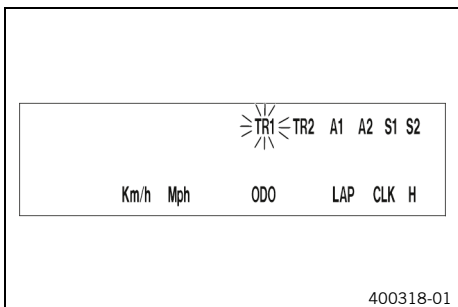

**Condition**

The motorcycle is stationary.

- Repeatedly press the button **+** briefly until **H** appears at the bottom right of the display.
- Press the button **+** for 2–3 seconds.
- ✓ The Setup menu is displayed and the active functions are shown.

**i** **Info**

If no button is pressed for 10–12 seconds, the settings are automatically saved.

If no button is pressed for 20 seconds, or if an impulse comes from the wheel speed sensor, the settings are automatically saved and the setup menu is closed.

- Repeatedly press the button **+** briefly until the desired function flashes.
- ✓ The selected function flashes.

**Activating the function**

- Press the button **+**.
- ✓ The symbol continues to appear in the display and the next function appears.

**Deactivating a function**

- Press the button **-**.
- ✓ The symbol disappears in the display and the next function appears.



### 3.28 Setting the clock

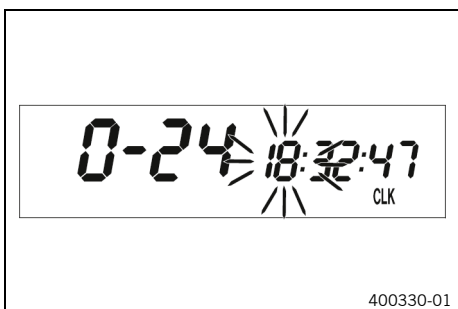

**Condition**

The motorcycle is stationary.

- Repeatedly press the button **+** briefly until **CLK** appears at the bottom right of the display.
- Press the button **+** for 2–3 seconds.
- ✓ The hour display flashes.
- Adjust hour display with the button **+** and/or button **-**.
- Wait 3 - 5 seconds.
- ✓ The next segment of the display flashes and can be set.
- You can set the following segments in the same way as the hours by pressing the button **+** and the button **-**.

**i** **Info**

The seconds can only be set to zero.

If no button is pressed for 15–20 seconds, or if an impulse comes from the wheel speed sensor, the settings are automatically saved and the setup menu is closed.



## 4 TECHNICAL SPECIFICATIONS

### 4.1 chassis tightening torques

|   |                                 |   |
|---|---------------------------------|---|
| Hose connector, active carbon filter            | -                               | 3.8 Nm (2.8 lbf ft)                       |
| Mushroom head screw for spoiler and seat        |                                 | 2.5 Nm (1.84 lbf ft)                      |
| Remaining screws, chassis                       | <b>EJOT PT®</b> K60x25-Z        | 2 Nm (1.5 lbf ft)                         |
| Screw, emergency OFF switch                     | <b>EJOT PT®</b> K50x18-T20      | 2 Nm (1.5 lbf ft)                         |
| Screw, fuel pump on fuel tank                   | <b>EJOT PT®</b> K60x30-Z        | 2.5 Nm (1.84 lbf ft)                      |
| Screw, hose clip, inlet sleeve                  |                                 | 2.8 Nm (2.07 lbf ft)                      |
| Screw, intake air temperature sensor            | <b>EJOT DELTA PT®</b> 50x18 T20 | 0.7 Nm (0.52 lbf ft)                      |
| Screw, oil fill level sensor                    | <b>EJOT PT®</b> 50x18-T25       | 2.5 Nm (1.84 lbf ft)                      |
| Screw, oil pump holder on oil tank              | <b>EJOTDELTA PT®</b> 45x12-Z    | 0.7 Nm (0.52 lbf ft)                      |
| Screw, pressure regulator                       | <b>EJOT PT®</b> K60x25-Z        | 2.3 Nm (1.7 lbf ft)                       |
| Screw, radiator hoses clip                      |                                 | 2.4 Nm (1.77 lbf ft)                      |
| Screw, subframe with filter box                 | <b>EJOT PT®</b> K60x20AL        | 5 Nm (3.7 lbf ft)                         |
| Screw, fixed grip                               | M4                              | 5 Nm (3.7 lbf ft)<br><b>Loctite®243™</b>  |
| Screw, throttle valve body cover                | M4                              | 2.6 Nm (1.92 lbf ft)                      |
| Spoke nipple, front wheel                       | M4.5                            | 6 Nm (4.4 lbf ft)                         |
| Spoke nipple, rear wheel                        | M4.5                            | 6 Nm (4.4 lbf ft)                         |
| Remaining nuts, chassis                         | M5                              | 5 Nm (3.7 lbf ft)                         |
| Remaining screws, chassis                       | M5                              | 5 Nm (3.7 lbf ft)                         |
| Screw, battery terminal                         | M5                              | 2.5 Nm (1.84 lbf ft)                      |
| Screw, frame protector                          | M5                              | 3 Nm (2.2 lbf ft)                         |
| Screw, light switch (150 EXC EU)                | M5                              | 1 Nm (0.7 lbf ft)                         |
| Screw, shock absorber adjusting ring            | M5                              | 5 Nm (3.7 lbf ft)                         |
| Screw, turn signal switch (150 EXC EU)          | M5                              | 1 Nm (0.7 lbf ft)                         |
| Nut, cable on starter motor                     | M6                              | 4 Nm (3 lbf ft)                           |
| Nut, throttle cable wire on throttle valve body | M6                              | 3 Nm (2.2 lbf ft)                         |
| Remaining nuts, chassis                         | M6                              | 10 Nm (7.4 lbf ft)                        |
| Remaining screws, chassis                       | M6                              | 10 Nm (7.4 lbf ft)                        |
| Screw, battery support bracket                  | M6                              | 6 Nm (4.4 lbf ft)                         |
| Screw, brake lever                              | M6                              | 5 Nm (3.7 lbf ft)                         |
| Screw, brake line guide for link fork           | M6                              | 4.5 Nm (3.32 lbf ft)                      |
| Screw, cable on starter relay                   | M6                              | 6 Nm (4.4 lbf ft)                         |
| Screw, chain guide on link fork at the front    | M6x45                           | 10 Nm (7.4 lbf ft)                        |
| Screw, chain guide on link fork at the rear     | M6x16                           | 10 Nm (7.4 lbf ft)                        |
| Screw, chain sliding guard                      | M6                              | 10 Nm (7.4 lbf ft)<br><b>Loctite®243™</b> |
| Screw, clutch lever                             | M6                              | 5 Nm (3.7 lbf ft)                         |

|   |       |   |
|---|-------|---|
| Screw, connector board incl. combination instrument   | M6    | 5 Nm (3.7 lbf ft)                           |
| Screw, fender to triple clamp                         | M6    | 12 Nm (8.9 lbf ft)                          |
| Screw, front brake disc                               | M6    | 14 Nm (10.3 lbf ft)<br><b>Loctite®243™</b>  |
| Screw, fuel tank spoiler on radiator                  | M6    | 6 Nm (4.4 lbf ft)                           |
| Screw, ground wire in tail section                    | M6    | 10 Nm (7.4 lbf ft)                          |
| Screw, oil pump                                       | M6    | 6 Nm (4.4 lbf ft)                           |
| Screw, oil tank cap                                   | M6    | 6 Nm (4.4 lbf ft)                           |
| Screw, oil tank on frame                              | M6    | 5 Nm (3.7 lbf ft)                           |
| Screw, push rod ball joint on the rear brake cylinder | M6    | 10 Nm (7.4 lbf ft)<br><b>Loctite®243™</b>   |
| Screw, rear brake disc                                | M6    | 14 Nm (10.3 lbf ft)<br><b>Loctite®243™</b>  |
| Screw, seat fixing                                    | M6    | 8 Nm (5.9 lbf ft)                           |
| Screw, silent block on frame                          | M6    | 6 Nm (4.4 lbf ft)                           |
| Screw, throttle grip                                  | M6    | 5 Nm (3.7 lbf ft)                           |
| Fuel connection on the fuel pump                      | M8    | 15 Nm (11.1 lbf ft)                         |
| Nut, pull switch (150 XC-W US)                        | M8    | 0.8 Nm (0.59 lbf ft)                        |
| Nut, rear sprocket screw                              | M8    | 35 Nm (25.8 lbf ft)<br><b>Loctite®2701™</b> |
| Nut, rim lock   | M8    | 12 Nm (8.9 lbf ft)                          |
| Rear brake lever stop nut                             | M8    | 20 Nm (14.8 lbf ft)                         |
| Remaining nuts, chassis                               | M8    | 25 Nm (18.4 lbf ft)                         |
| Remaining screws, chassis                             | M8    | 25 Nm (18.4 lbf ft)                         |
| Screw, bottom triple clamp                            | M8    | 15 Nm (11.1 lbf ft)                         |
| Screw, chain sliding piece                            | M8    | 15 Nm (11.1 lbf ft)                         |
| Screw, engine brace                                   | M8x15 | 25 Nm (18.4 lbf ft)<br><b>Loctite®2701™</b> |
| Screw, engine brace                                   | M8x20 | 25 Nm (18.4 lbf ft)<br><b>Loctite®243™</b>  |
| Screw, engine sprocket cover                          | M8    | 15 Nm (11.1 lbf ft)                         |
| Screw, fork stub                                      | M8    | 15 Nm (11.1 lbf ft)                         |
| Screw, front brake caliper                            | M8    | 25 Nm (18.4 lbf ft)<br><b>Loctite®243™</b>  |
| Screw, handlebar clamp                                | M8    | 20 Nm (14.8 lbf ft)                         |
| Screw, manifold                                       | M8    | 15 Nm (11.1 lbf ft)                         |
| Screw, rear sprocket                                  | M8    | 35 Nm (25.8 lbf ft)<br><b>Loctite®2701™</b> |
| Screw, side stand attachment                          | M8    | 33 Nm (24.3 lbf ft)<br><b>Loctite®2701™</b> |
| Screw, subframe bottom                                | M8    | 30 Nm (22.1 lbf ft)<br><b>Loctite®2701™</b> |
| Screw, subframe, top                                  | M8    | 35 Nm (25.8 lbf ft)<br><b>Loctite®243™</b>  |
| Screw, top steering stem                              | M8    | 20 Nm (14.8 lbf ft)                         |
| Screw, top triple clamp                               | M8    | 20 Nm (14.8 lbf ft)                         |
| Screw, wheel speed sensor                             | M8    | 4.5 Nm (3.32 lbf ft)                        |

## 4 TECHNICAL SPECIFICATIONS

|   |         |  |
|---|---------|--|
| Engine bracket screw                          | M10     | 60 Nm (44.3 lbf ft)                        |
| Nut, foot brake lever                         | M10     | 45 Nm (33.2 lbf ft)                        |
| Remaining nuts, chassis                       | M10     | 45 Nm (33.2 lbf ft)                        |
| Remaining screws, chassis                     | M10     | 45 Nm (33.2 lbf ft)                        |
| Screw, brake caliper on brake caliper bracket | M10     | 45 Nm (33.2 lbf ft)<br><b>Loctite®243™</b> |
| Screw, handlebar support                      | M10     | 40 Nm (29.5 lbf ft)<br><b>Loctite®243™</b> |
| Temperature sensor water to t-plate           | M10     | 10 Nm (7.4 lbf ft)                         |
| Screw, bottom shock absorber                  | M12     | 80 Nm (59 lbf ft)<br><b>Loctite®2701™</b>  |
| Screw, top shock absorber                     | M12     | 80 Nm (59 lbf ft)<br><b>Loctite®2701™</b>  |
| Nut, fork pivot                               | M16x1.5 | 100 Nm (73.8 lbf ft)                       |
| Screw, front wheel spindle                    | M20x1.5 | 35 Nm (25.8 lbf ft)                        |
| Screw, top steering head                      | M20x1.5 | 12 Nm (8.9 lbf ft)                         |
| Nut, wheel spindle, rear                      | M22x1.5 | 80 Nm (59 lbf ft)                          |
| Screw-in fitting, cooling system              | M24x1.5 | 7.5 Nm (5.53 lbf ft)                       |

### Engine oil, 2-stroke

**Standard/classification**

- JASO FD (📖 p. 39)

**Guideline**

- Only use high-grade 2-stroke engine oil from a reputable brand.

fully synthetic

**Recommended supplier****MOTOREX®**

- Cross Power 2T

### Super unleaded (ROZ 95)

**Standard/classification**

- DIN EN 228 (ROZ 95)

**Guideline**

- Only use super unleaded fuel that matches or is equivalent to the specified standard.
- Fuel with an ethanol content of up to 10% (E10 fuel) is safe to use.

**Info**

Do **not** use fuel containing methanol (e.g., M15, M85, M100) or more than 10% ethanol (e.g., E15, E25, E85, E100).

### Silicone spray

Recommended supplier

**MOTOREX®**

– Silicone Spray



**JASO FD**

JASO FD is a classification for a 2-stroke engine oil that was specifically developed for the extreme demands of racing. Thanks to first-rate synthetic esters and specially designed additives, superb combustion is achieved even under extreme operating conditions.



3214967en

11.07.2023

