



KAZALO OPISNE DOKUMENTACIJE e08157
INDEX TO THE INFORMATION PACKAGE e08157

Revision: 03

Homologacijska številka: **e26*134/2014*2018/295G*08157**
Approval number:

Razširitev številka: **03**
Extension number:

Zgodovina homologacije / Opisne dokumentacije:
Type approval / Information package history:

Razširitev / Revizija: Extension / Revision:	Zadeva: Subject:	Datum izdaje: Date of issue:	Skupno št. strani: Total No. of pages:
00/00	Odobritev homologacije Granting of type approval	07.12.2020	36
01/01	Razširitev homologacije Extension of type approval	22.01.2021	11
02/02	Razširitev homologacije Extension of type approval	12.10.2021	11
03/03	Razširitev homologacije Extension of type approval	08.05.2023	47

Poročilo o preskusu: **20-00040-CM-GBM-03**
Test report:

Število strani: **42**
Number of pages:

datum izdaje: **24.04.2023**
date of issue:

datum zadnje spremembe: /
date of latest amendment:

Opisni list/Tehnični opis naprave: **M-HFT003**
Information document/Technical description of the device:

Število strani: **2**
Number of pages:

datum izdaje: **24.04.2023**
date of issue:

datum zadnje spremembe: /
date of latest amendment:

Risba(e)¹:
Drawing(s)¹:

Število strani: **1**
Number of pages:

datum zadnje spremembe: /
date of latest amendment:

Navodila za vgradnjo in uporabo:
Mounting and handling instructions:

Število strani:
Number of pages:

datum zadnje spremembe: /
date of latest amendment:

Ostala dokumentacija:
Other documentation:

Število strani: **2**
Number of pages:



¹ kosovnice, slike, sheme in diagrami / ¹ bill of materials, pictures, schematics and diagrams

**SLOVENIAN TRAFFIC SAFETY AGENCY,
KOTNIKOVA ULICA 19a,
1000 LJUBLJANA,
SLOVENIA**

We, Akrapovič d.d., Malo Hudo 8a. 1295 Ivančna Gorica, Slovenia hereby ask STSA to grant **an extension** to an approval against **e26*134/2014*2018/295G*08157*02** for the following product:
Exhaust system for Motorcycles - muffler:

Type: **M-HFT003**

Version: **M-HFT003 03T (SS / Ti / Ti)**
M-HFT003 02T (SS / Ti / Ca)
M-HFT003 04T (Ti / Ti / SS)
M-HFT003 05T (Ti / Ti / Ca)
M-HFT003 06T (Ti / Ti / Ti)
M-HFT003 03TBL (SS / Ti / Ti)
M-HFT003 02TBL (SS / Ti / Ca)
M-HFT003 04TBL (Ti / Ti / SS)
M-HFT003 05TBL (Ti / Ti / Ca)
M-HFT003 06TBL (Ti / Ti / Ti)

Manufacturer: **Akrapovič d.d.**
Malo Hudo 8a
1295 Ivančna Gorica
Slovenia

We declare that we have not applied to any other Approval Authority in the EU Member States for this approval.

We have requested **TÜV SÜD Auto Service GmbH**, to carry out all testing required by the directive and/or regulation that the approval is sought against and to present the entire documentation for the approval.

Yours sincerely,

Date: 02.03.2023

Akrapovič d.d.
Davorin Dobočnik, CEO



AKRAPOVIČ d.d.
Malo Hudo 8a, 1295 Ivančna Gorica.
Slovenija



**PRÜFBERICHT
ERWEITERUNG 03
TEST REPORT
EXTENSION 03**

Nr. / no. 20-00040-CM-GBM-03

über die Prüfung zur Bauartgenehmigung einer Nicht-Originalauspuffanlage oder von Einzelteilen hiervon als selbstständige technische Einheit für Krafträder /

about a test regarding a component type-approval for non-original exhaust system or components thereof, as a technical unit for motorcycles

Verordnung / Regulation (EU) 134/2014 vom / dated 16.12.2013
zuletzt geändert / last amended (EU) 2018/295 vom / dated 15.12.2017
Kodierung / Codification G

zur Ergänzung der Verordnung (EU) Nr. 168/2013 des Europäischen Parlaments und des Rates. /
supplementing Regulation (EU) 168/2013 of the European Parliament and the Council.

Genehmigungsstand / Approval status	
<input type="checkbox"/>	Erteilung einer Typgenehmigung <i>Granting of a type approval</i>
<input checked="" type="checkbox"/>	Nachtrag/Änderung zur Typgenehmigung Nr. e26*134/2014*2018/295G*08157*02 <i>Extension/correction to type approval no.</i>

Gründe der Erweiterung / Reasons for extension

Es wird geändert /
It will be changed:

- Der Verwendungsbereich wird erweitert /
Extension of application range

Es wird aktualisiert /
It will be updated:

- Anlagen 1/03 und 2/03 /
Enclosures 1/03 and 2/03



0. Allgemeine Angaben / General information

0.1. Fabrikmarke / Make: AKRAPOVIČ

0.2. Typ / Type: M-HFT003

0.2.1. Ausführungen / Variants:

Ausführungen / Variants	Material / Material		
	Rohre / Tubes	Außenmantel / Sleeve	Endkappe / End cap
M-HFT003 03T	VA / Stainless steel	Titan / Titanium	Titan / Titanium
M-HFT003 02T	VA / Stainless steel	Titan / Titanium	Karbon / Carbon
M-HFT003 04T	Titan / Titanium	Titan / Titanium	VA / Stainless steel
M-HFT003 05T	Titan / Titanium	Titan / Titanium	Karbon / Carbon
M-HFT003 06T	Titan / Titanium	Titan / Titanium	Titan / Titanium
M-HFT003 03TBL	VA / Stainless steel	Titan / Titanium	Titan / Titanium
M-HFT003 02TBL	VA / Stainless steel	Titan / Titanium	Karbon / Carbon
M-HFT003 04TBL	Titan / Titanium	Titan / Titanium	VA / Stainless steel
M-HFT003 05TBL	Titan / Titanium	Titan / Titanium	Karbon / Carbon
M-HFT003 06TBL	Titan / Titanium	Titan / Titanium	Titan / Titanium

Die Ausführungen unterscheiden sich in der Verwendung verschiedener Werkstoffe. Der konstruktive Aufbau ist gleich. Das akustische Verhalten ist als gleichwertig zu betrachten. /

The variants vary because different materials are used. The basic construction remains the same. The acoustic behaviour is to be regarded as equivalent.



0. Allgemeine Angaben (Fortsetzung) / General information (continuation)

- 0.3. Name und Anschrift des Herstellers /
Name and address of manufacturer: Akrapovič d.d.
Malo Hudo 8a
SLO-1295 Ivančna Gorica
- 0.4. Name und Anschrift des Beauftragten /
Name and address of authorized agent: entfällt / *n.a.*
- 0.5. Nr. des Beschreibungsbogens /
No. of information document: M-HFT003
Ausgabedatum / *Date:* 24.04.2023
- 1.0. Klasse der Fahrzeuge für, die die
Anlage bestimmt ist /
Class of the vehicles the unit is used for: L3e
- 1.1. Beschreibung der Fahrzeuge für,
die die Einrichtung bestimmt ist /
Description of the vehicles
the unit is used for: siehe Anlage 2/03 / *see enclosure 2/03*

2. Angaben zum Prüfobjekt / Composition of the separate technical unit

- 2.1. Art der Technischen Einheit /
Kind of technical unit: unverändert / *without changes*
- 2.2. Ort der Kennzeichnung /
Place of marking: unverändert / *without changes*
- 2.3. Zusammenstellung der techn. Einheit /
Composition of the separate
technical unit: siehe Anlage 1/03 / *see enclosure 1/03*
- 2.4. Lage und Richtung der Auspuffmündung /
Position and direction of the tail pipe: unverändert / *without changes*

3. Prüfprotokoll / Test report

Die Prüfungen wurden in 2 Versuchsreihen C und D mit folgenden Fahrzeugen durchgeführt. /

The tests were carried out in 2 series C and D with following vehicles:

Versuchsreihe C / Series C: (Ild. Nr. / no. 15, Messdatum / Date 05.04.2023)

3.1. Fahrzeug / Vehicle

3.1.1. Typ / Type:	KTM CV1 Adventure
3.1.1.1 Variante / Version / Variant / Version:	A / -
3.1.1.2 Fahrzeugkategorie / Category:	L3e-A3
3.1.1.3 Handelsbezeichnung / Model:	KTM 790 Adventure
3.1.2. Hersteller / Manufacturer:	KTM (A)
3.1.3. Genehmigungs-Nr. / Homologation no.:	e1*168/2013*00328*
3.1.3.1 Nachtrag bzw. Erweiterung / Extension:	00
3.1.4. Fahrzeugidentifizierungsnummer / Vehicle identification no.:	VBKTS3404PH700004
3.1.5. Baujahr / Year of manufacture:	2023
3.1.6. Km-Stand / Kilometers:	29
3.1.7. Zul. Gesamtgewicht / Total weight:	450 kg

3.2. Antriebsmaschine / Engine

3.2.1. Hersteller / Manufacturer:	KTM
3.2.2. Typ / Type:	646
3.2.3. Hubraum / Engine capacity:	799 cm ³
3.2.4. Höchstleistung / Max. net power:	70 kW bei / at 8250 min ⁻¹
3.2.5. Max. Drehmoment / Max. net torque:	87 Nm bei / at 6500 min ⁻¹

3.3. Kraftübertragung / Transmission

3.3.1. Art der Kraftübertragung / Kind of transmission:	mechanisch / mechanical
3.3.2. Getriebe / Gearbox:	6-Gang-manuell / 6-gear-manual



3. **Prüfprotokoll** (Fortsetzung) / **Test report** (continuation)

3.3.3. Übersetzungsverhältnisse / *Transmission ratios*

primär / *primary* / sekundär / *secondary*: - / 2,81

Höchstgeschwindigkeit / *Top speed*: 192 km/h

Reifen / *Tires*:
vorne / *front*: Pirelli Scorpion Rally STR
90/90-21 54V
hinten / *rear*: 150/70 R18 70V

3.4. **Zusammenbau der Auspuffanlage / *Assembly of the exhaust system*** (Teile lfd. Nr. lt. Anlage 1/03 / *no. of parts acc. enclosure 1/03*)

Versuchsreihe C / *Series C*: 1)2)3a)

3.5. **Messung der Geräuschwerte / *Acoustic measurements***

3.5.1. Hersteller des Messgerätes /
Manufacturer of test equipment: MÜLLER-BBM

3.5.2. Typ des Messgerätes /
Type of the test equipment: PAK MK II Configuration

3.5.3. Fahrgeräusch, Standgeräusch /
Drive by noise, stationary noise: nach ECE-R 41.04 /
according ECE-R 41.04

3.5.4. Beladungszustand bei der Fahr-
geräuschmessung /
Load condition during drive by test: Leergewicht zuzüglich 75 kg Fahrer /
Unloaded weight plus 75 kg driver

3.5.5. Abweichung bei Kalibrierung /
Deviation at calibration: < 0.2 dB(A)

3.6. **Messung der Leistung / *Power measurement***

3.6.1. Messung der Leistungskurve mit Nicht-Originalauspuffanlage /
Testing of max. power with non-original exhaust system:

Die gemessene Nennleistung und die zugehörige Drehzahl liegen im Toleranzbereich von 5% im Vergleich zu den mit der Originalauspuffanlage gemessenen Werten (siehe Anlage). /

The tested max. power and the engine speed is in the 5% tolerance in comparison with the original exhaust system (see enclosure).



3. **Prüfprotokoll** (Fortsetzung) / **Test report** (continuation)

3.6.2. Messung der Höchstgeschwindigkeit mit Nicht-Originalauspuffanlage / *Testing of top speed with non-original exhaust system:*

entfällt, da Fahrzeugklasse /
not applicable, because vehicle class: L3e

Versuchsreihe D / Series D: (lfd. Nr. / *no.* 11, Messdatum / *Date* 05.04.2023)

3.1. **Fahrzeug / Vehicle**

3.1.2. Typ / <i>Type</i> :	KTM R2 Adventure
3.1.1.1 Variante / <i>Version / Variant / Version</i> :	D / -
3.1.1.2 Fahrzeugkategorie / <i>Category</i> :	L3e-A3
3.1.1.3 Handelsbezeichnung / <i>Model</i> :	KTM 890 SMT
3.1.2. Hersteller / <i>Manufacturer</i> :	KTM (A)
3.1.3. Genehmigungs-Nr. / <i>Homologation no.</i> :	e1*168/2013*00250*
3.1.3.1 Nachtrag bzw. Erweiterung / <i>Extension</i> :	02
3.1.4. Fahrzeugidentifizierungsnummer / <i>Vehicle identification no.</i> :	VBKTS6403MM813639
3.1.5. Baujahr / <i>Year of manufacture</i> :	2023
3.1.6. Km-Stand / <i>Kilometers</i> :	6093
3.1.7. Zul. Gesamtgewicht / <i>Total weight</i> :	450 kg

3.2. **Antriebsmaschine / Engine**

3.2.1. Hersteller / <i>Manufacturer</i> :	KTM
3.2.2. Typ / <i>Type</i> :	636
3.2.3. Hubraum / <i>Engine capacity</i> :	889 cm ³
3.2.4. Höchstleistung / <i>Max. net power</i> :	77 kW bei / <i>at</i> 8000 min ⁻¹
3.2.5. Max. Drehmoment / <i>Max. net torque</i> :	100 Nm bei / <i>at</i> 6500 min ⁻¹

3. **Prüfprotokoll** (Fortsetzung) / **Test report** (continuation)

3.3. **Kraftübertragung / Transmission**

- 3.3.1. Art der Kraftübertragung /
Kind of transmission: mechanisch / *mechanical*
- 3.3.2. Getriebe / *Gearbox*: 6-Gang-manuell / *6-gear-manual*
- 3.3.3. Übersetzungsverhältnisse /
Transmission ratios
primär / *primary* / sekundär / *secondary*: - / 2,68
- Höchstgeschwindigkeit / *Top speed*: 200 km/h
- Reifen / *Tires*: Michelin Power GP
vorne / *front*: 120/70 ZR17 58W
hinten / *rear*: 180/55 ZR17 73W

3.4. **Zusammenbau der Auspuffanlage / Assembly of the exhaust system** (Teile lfd. Nr. lt. Anlage 1/03 / *no. of parts acc. enclosure 1/03*)

Versuchsreihe D / Series D: 1)2)3a)

3.5. **Messung der Geräuschwerte / Acoustic measurements**

- 3.5.1. Hersteller des Messgerätes /
Manufacturer of test equipment: MÜLLER-BBM
- 3.5.2. Typ des Messgerätes /
Type of the test equipment: PAK MK II Configuration
- 3.5.3. Fahrgeräusch, Standgeräusch /
Drive by noise, stationary noise: nach ECE-R 41.04 /
according ECE-R 41.04
- 3.5.4. Beladungszustand bei der Fahr-
geräuschmessung /
Load condition during drive by test: Leergewicht zuzüglich 75 kg Fahrer /
Unloaded weight plus 75 kg driver
- 3.5.5. Abweichung bei Kalibrierung /
Deviation at calibration: < 0.2 dB(A)



3. **Prüfprotokoll** (Fortsetzung) / **Test report** (continuation)

3.6. **Messung der Leistung / Power measurement**

3.6.1. Messung der Leistungskurve mit Nicht-Originalauspuffanlage / *Testing of max. power with non-original exhaust system:*

Die gemessene Nennleistung und die zugehörige Drehzahl liegen im Toleranzbereich von 5% im Vergleich zu den mit der Originalauspuffanlage gemessenen Werten (siehe Anlage). /

The tested max. power und the engine speed is in the 5% tolerance in comparison with the original exhaust system (see enclosure).

3.6.2. Messung der Höchstgeschwindigkeit mit Nicht-Originalauspuffanlage / *Testing of top speed with non-original exhaust system:*

entfällt, da Fahrzeugklasse /
not applicable, because vehicle class: L3e

3.7. **Konditionierung der Auspuffschalldämpferanlage / *Conditioning of silencer system***

durch Druckschwingungen / *by pulsation*

3.8. **Ergebnisse / Test results**

Die Ergebnisse der Prüfungen hinsichtlich / *The test results of*

3.8.1. Geräuschmessung / *Noise testing*

3.8.2. Leistungsmessung / *Power measurement*

sind der als Anlage beigefügten Tabellen zu entnehmen. /
are attached in the enclosures.

Aufgrund der Messung mit dem/n o.g. Fahrzeug/en können auch die in Anlage 2 aufgeführten Krafräder, die die gleiche Serien-Auspuffanlage besitzen und gleiche bzw. geringere Motorleistung haben, mit in den Verwendungsbereich aufgenommen werden. /

All motorcycles with the same serial exhaust system and same or less performance mentioned in enclosure 2 can be taken into the field of application due to the measurement with the above-named motorcycle/s.

3.8.3. Die beschriebene Nicht-Originalauspuffanlage / Technische Einheit darf an den in der Anlage 2 aufgeführten Kraftfahrzeugen unter den dort genannten Bedingungen verwendet werden. /

The described non-original exhaust system / technical unit is suitable for an application at the vehicles listed in enclosure 2.



3. **Prüfprotokoll** (Fortsetzung) / **Test report** (continuation)

- 3.8.4. Die allgemeinen Spezifikationen gemäß (EU) 134/2014; Anhang IX; Anlage 2; Abschnitt 3.5.1. werden durch die Nicht-Originalauspuffanlage als technische Einheit erfüllt. /
The general specifications regarding (EU) 134/2014; Annex IX; Appendix 2; Clause 3.5.1. are fulfilled by the non-original exhaust system as technical unit.

4. **Anlagen / Enclosures**

- Anlage 1/03, Teile der technischen Einheit (1 Seite / Page)
Enclosure 1/03, Composition of the separate technical unit
- Anlage 2/03, Verwendungsbereich (2 Seiten / Pages)
Enclosure 2/03, Field of application
- Anlage 3/03, Ergebnisse der Geräusch- und Leistungsmessungen(1 Seite / Page)
Enclosure 3/03, Results of noise testing and power measurements
- Anlage, Protokoll Geräuschmessung (26 Seiten / Pages)
Enclosure, Protocol noise test
- Anlage, Leistungskurve (2 Seiten / Pages)
Enclosure, Performance diagram

5. **Schlussbescheinigung / Summary**

Die erwähnte Beschreibungsbogen und der darin beschriebene Typ entsprechen der genannten Prüfgrundlage. Der ungünstigste Fall wurde entsprechend der Prozessbeschreibung "Anforderungen an Prüfberichte (AS-PB-T-02)" bestimmt.

Der Prüfbericht darf nur vom Auftraggeber und nur in vollem Wortlaut vervielfältigt und weitergegeben werden. Eine auszugsweise Vervielfältigung und Veröffentlichung des Prüfberichtes sind nur nach schriftlicher Genehmigung zulässig. /

The mentioned information document and the type described therein are in accordance with the test basis mentioned above. The worst-case was selected in accordance with document "Requirements for Test Reports (AS-PB-T-02)".

The test report may be reproduced and published in full and by the client only. It can be reproduced partially with the written permission of the test laboratory only.



5. **Schlussbescheinigung** (Fortsetzung) / **Summary** (continuation)

TÜV SÜD Auto Service GmbH ist benannt als Technischer Dienst durch /
TÜV SÜD Auto Service GmbH is designated as Technical Service by:

Genehmigungsbehörde <i>Approval authority</i>	Land <i>Country</i>	Registriernummer <i>Registration number</i>
Kraftfahrt-Bundesamt (KBA)	Deutschland <i>Germany</i>	KBA-P 00100-10
Vehicle Certification Agency (VCA)	Vereinigtes Königreich <i>United Kingdom</i>	VCA-TS-006
Approval Authority of the Netherlands (RDW)	Niederlande <i>The Netherlands</i>	RDWT-082-xx
National Standards Authority of Ireland (NSAI)	Irland <i>Ireland</i>	Technical Service Number: 49
Vehicle Safety Certification Center (VSCC)	Taiwan <i>Taiwan</i>	DE04-06-2
Société Nationale de Certification et d'Homologation s.à r.l. (SNCH)	Luxemburg <i>Luxembourg</i>	13/B(g)
Swedish Transport Agency	Schweden <i>Sweden</i>	TT 0024

Dieser Bericht umfasst Seite 1 bis 10. /
This test report contains the pages 1 up to 10.

München, 24.04.2023



F. Rinske (B. Eng.)
Sachverständiger / *Recognized Expert*
fr

M-HFT003_SLO_295_EC_03.doc



Prüfbericht Nr. / *Test report No.*: 20-00040-CM-GBM-03
 Hersteller / *Manufacturer*: Akrapovič, d.d., SLO-1295 Ivančna Gorica
 Typ / *Type*: M-HFT003



Auto Service

ANLAGE 1/03
ENCLOSURE 1/03

Teile der technischen Einheit / *Composition of the separate technical unit*

Lfd. Nr. / No.	Einzelteile, Abmessungen in mm / <i>Components parts, dimensions in mm</i>	Abmessungen des Teiles in mm bzw. Originalteil / Ersatzteil / <i>Dimensions of the part in mm or original part / replacement part</i>	Teilenummer bzw. Genehmigungsnummer / <i>Part no. or homologation no.</i>
1)	Krümmerröhre / <i>Header pipes</i>	Originalteile / <i>Original parts</i>	-
2)	Vorschalldämpfer mit Katalysator / <i>Pre-silencer with catalytic converter</i>	Originalteile / <i>Original parts</i>	-
3a)	Schalldämpfer / <i>Silencer</i> (Eintrittsrohr / <i>Inlet pipe</i> Ø 63,8 Austrittsrohr / <i>Outlet pipe</i> Ø 35)	hexagonal / <i>hexagonal</i> 115 x 145,2 Länge ohne Endkappen / <i>Length without endcaps</i> 320	M-HFT003 e26*08157*G E26 92R-02 8157

M-HFT003_SLO_295_EC_13.doc



Prüfbericht Nr. / Test report No.: 20-00040-CM-GBM-03
 Hersteller / Manufacturer: Akrapovič, d.d., SLO-1295 Ivančna Gorica
 Typ / Type: M-HFT003



Auto Service

ANLAGE 2/03
ENCLOSURE 2/03

Verwendungsbereich / Field of application

Die Fahrzeuge erfüllen - beziehend auf ihre Fahrzeugtypgenehmigung - die Umweltafordersstufen:
 The vehicles fulfil - regarding their Whole Vehicle Type Approval (WVTA) - the environmental steps:

Euro (4/5)
 Euro (4/5)



Lfd. Nr.	Hersteller	Fabrikmarke	Handelsbezeichnung	Fahrzeugtyp Genehmigung Nr.	Var. Vers.	Motortyp 4 Takt	Hubraum in cm ³	Nenn-leistung kW/min ⁻¹	Sonstige bestimmende Merkmale	Anordnung entspr. Anl. 1/03 lfd. Nr.
No. of vehicle	Manufacturer	Trade mark	Commercial description	Vehicle type no. of homologation	Var. Vers.	Engine type 4 Stroke	Engine capacity in cm ³	max. engine power kW/min ⁻¹	Additional remarks	Composition reg. enclosure no. 1/03
1)	KTM (A)	KTM	KTM 790 Adventure	KTM 790 Adventure e1*168/2013*00149*	alle all	635	799	70/8250	mit Kat.*) / with cat.	1)2)3a)
2)			KTM 790 Adventure R							
3)			KTM 790 Adventure R Rally							
4)			KTM 890 Adventure	KTM 790 Adventure e1*168/2013*00148*		636	889	70/8000		
5)			KTM 790 Adventure			635	799	35/4750		
6)			KTM 790 Adventure R							
7)			KTM 890 Adventure	KTM R2 Adventure e1*168/2013*00250*		636	889	35/4250		
8)			KTM 890 Adventure			636	889	77/8000		
9)			KTM 890 Adventure R							
10)			KTM 890 Adventure R Rally							
11)			KTM 890 SMT							

Prüfbericht Nr. / Test report No.: 20-00040-CM-GBM-03
 Hersteller / Manufacturer: Akrapovič, d.d., SLO-1295 Ivančna Gorica
 Typ / Type: M-HFT003



Auto Service

ANLAGE 2/03
ENCLOSURE 2/03

Verwendungsbereich / Field of application

Lfd. Nr.	Hersteller	Fabrikmarke	Handelsbezeichnung	Fahrzeugtyp Genehmigung Nr.	Var. Vers.	Motortyp 4 Takt	Hubraum in cm ³	Nennleistung kW/min ⁻¹	Sonstige bestimmende Merkmale	Anordnung entspr. Anl. 1/03 lfd. Nr.
No. of ve- hicle	Manufac- turer	Trade mark	Commercial des- cription	Vehicle type no. of homologation	Var. Vers.	Engine type 4 Stroke	Engine capacity in cm ³	max. engine power kW/min ⁻¹	Additional remarks	Composition reg. enclosure no. 1/03
12)	KTM (A)	Husqvarna	Husqvarna 901 Norden	HQV N e1*168/2013*00295*	alle all	637	889	77/8000	mit Kat.*) / with cat.	1)2)3a)
13)			Husqvarna 901 Norden Expedition							
14)		KTM	KTM 790 Adventure	KTM CV1 Adventure e1*168/2013*00337*		646	799	35/4500		
15)				KTM CV1 Adventure e1*168/2013*00328*				70/8250		

*) Die serienmäßigen Katalysatoren bleiben unverändert im Abgassystem. Eine Verschlechterung des Abgasverhaltens ist nicht zu erwarten. /
 The original catalytic converter remains in the exhaust system. A degradation of catalyst efficiency is not expected.

M-HFT003_SLO_295_EC_23.doc





ANLAGE 3/03
ENCLOSURE 3/03

Ergebnisse der Geräusch- und Leistungsmessungen / Results of noise testing and power measurements

Lfd. Nr. Fahrzeug	Leistung Serie kW/min ⁻¹	Leistung Austausch kW/min ⁻¹	V _{max} Serie km/h	V _{max} Aus- tausch km/h	Fahrgeräusch in dB(A) / Sound level driving vehicle in dB(A)					Standgeräusch in dB(A) / Sound level stationary vehicle in dB(A)			
					gemessen in Gang	Grenz- wert ¹⁾	Serie gemes- sen ²⁾	Austausch gemessen ²⁾	bei km/h	lt. Fzg. BE	Serie gemes- sen	Austausch gemessen	bei min ⁻¹
No. of vehicle	Engine power original kW/min ⁻¹	Engine power non-original kW/min ⁻¹	V _{max} original km/h	V _{max} non original km/h	measured in gear ratio	Limit value ¹⁾ SL _{EU4}	original mea- sured ²⁾ L _{urban}	non- original measured ²⁾ L _{urban}	at km/h	Vehicle type hom.	original mea- sured	non- original measured	at min ⁻¹
15) C:	70/8250	70/8250	-	-	4	77	77,5	77,2	50	89	92	89	4125
11) D:	77/8000	77/8000	-	-	4	77	76,9	77,0	50	88	90	89	4000

1) Grenzwert der Richtlinienfassung, die bei Erteilung der Fahrzeuggenehmigung Gültigkeit hatte. /
 Limit value of directive which was valid by vehicle type homologation.

2) Betriebsart / Operating mode: Street

Anmerkungen / Remarks:

- Das Prüffahrzeug wurde zusätzlich in den weiteren Betriebsarten gemessen. /
 Test vehicle had been tested in additional driving modes.
- Die verschiedenen Betriebsarten haben keinen signifikanten Einfluss auf den Geräuschpegel und Beschleunigungsverhalten. /
 Different driving modes have no significant influence in sound pressure level and acceleration.

M-HFT003_SLO_295_EC_33.doc



Laboratory Report

V00

Test standard:
UN-R 041

Level of amendment:
series of amendments 04, supplement 10

Title:
Noise of motor cycles

Manufacturer:
Akrapovič d.d.

Type:
M-HFT003

Subject of testing:
Component



0 General

- | | | |
|-------|---|--|
| 0.1 | Make
(trade name of manufacturer): | Akrapovič |
| 0.2 | Type: | M-HFT003 |
| 0.2.1 | Commercial description: | M-HFT003 |
| 0.3 | Means of identification of type, if
marked on the vehicle: | M-HFT003 |
| 0.3.1 | Location of that marking: | On exhaust |
| 0.4 | Category of vehicle: | L3e |
| 0.5 | Manufacturer's name and address: | Akrapovič d.d.
Malo Hudo 8a
1295 Ivančna Gorica (SI) |
| 0.8 | Name and address of assembly
plant: | Akrapovič d.d., PE Crnomelj
Ulica heroja Stariha 24
8340 Crnomelj (SI) |
| 0.9 | Name and address of
representative: | n.a. |

1 Test conditions

Tests are carried out in compliance with the given requirements of the standard mentioned above.

x	fulfilled
	not fulfilled



2 Attachments

2.1	Test report:	No.:	U1E60002-00
		Date of issue:	06.04.2023
2.2	Test report:	No.:	U1E60003-00
		Date of issue:	06.04.2023



3 Statement of conformity

The devices under test are in compliance with the test standard mentioned above.
 With regard to the required level of performance to be achieved, the test specimens were representative for the type.

The tests were carried out in accordance to the relevant requirements of the

EN ISO/IEC 17025 EN ISO/IEC 17020

Test Laboratory
SGS-TÜV Saar GmbH

notified by

KBA Krafftahrt-Bundes- amt, Germany No. KBA-P 00084-10	NSAI National Standards Authority of Ireland No. 101	RDW Rijksdienst voor het Wegverkeer, The Netherlands No. 99050064 00	TRANSPORT STYRELSEN, Sweden No. TT 0015
---	--	---	---

**Formal review
(conformity check)**

Efrossina Daltcheva

Signature

Authorized by expert

Christoph Wibmer

Apr 11, 2023

Signature



This document shall be reproduced and published in full only and by the client only. It shall be reproduced partially with the written permission of the Test Laboratory only.

This document is issued by the Company subject to its General Conditions of Service (www.sgsgroup.de/agb). Attention is drawn to the limitations of liability, indemnification and jurisdictional issues established therein. This document is an original. If the document is submitted digitally, it is to be treated as an original within the meaning of UCP 600. Any holder of this document is advised that information contained hereon reflects the Company's findings at the time of its intervention only and within the limits of client's instructions, if any. The Company's sole responsibility is to its Client and this document does not exonerate parties to a transaction from exercising all their rights and obligations under the transaction documents. Any unauthorized alteration, forgery or falsification of the content or appearance of this document is unlawful and offenders may be prosecuted to the fullest extent of the law.

To assess the conformity, the laboratory refers to the "scope classification" of the Kraftfahrt-Bundesamt (KBA) – Federal Motor Transport Authority (in its valid version at the time of testing) and the specified consideration of the measurement uncertainty for the related test procedure.

In case the measurement uncertainty does not need to be considered according to the scope classification, the laboratory considers the result conform if its measured value is within the specification.

In case the measurement uncertainty does need to be considered according to the scope classification, the laboratory considers the result conform if its value incl. its measurement uncertainty is within the specification.

- End of Laboratory Report -



Test chart 1

1. Vehicle

1.1	Manufacturer / VIN:	KTM / VBKTS3404PH700004
1.2	Commercial name / Type:	KTM 790 Adventure / KTM CV1 Adventure
1.3	Variant / Version:	A / ---
1.4	Vehicle class:	L3e-A3
1.5	Type approval number:	Prototype
1.6	Vehicle kerb weight (m_{kerb})[kg]:	218
1.7	Mass of the vehicle in running order (m_{ro}) [kg]:	293
1.8	Vehicle test mass (m_t with rider) [kg]:	287
1.9	Technically permissible max. laden mass (M) [kg]:	450
1.10	Power to mass ratio index (PMR):	238,9
1.11	Vehicle length [m]:	2,22
1.12	Mileage:	29

2. Engine

2.1	Manufacturer / Engine code:	KTM / P-A646*00001		
2.2	Cycles:	<input checked="" type="checkbox"/> four stroke	<input type="checkbox"/> two stroke	<input type="checkbox"/> n.a.
2.3	Number and arrangement of cylinders:	2 / In-Line		
2.4	Working principle:	<input checked="" type="checkbox"/> positive ignition	<input type="checkbox"/> compression ignition	<input type="checkbox"/> electric
2.5	Rated power [kW / min ⁻¹]:	70 / 8250		
2.6	Idle engine speed [min ⁻¹]:	1400		
2.7	Cylinder capacity [cm ³]	799		

3. Transmission

3.1	Type:	<input type="checkbox"/> automatic gearbox	<input checked="" type="checkbox"/> manual gearbox
3.2	Identifier:	---	
3.3	No. of gears:	6	
3.4	Final drive ratio (Prime:Secondary):	-/45	
3.5	Driving mode(s):	Street / Rain / Offroad	



4. Equipment

4.1 Pre Catalysator(s)

Make: ---
 Type (left/right): --- / ---

4.2 Catalysator(s)

Make: KTM
 Type (left/right): --- / KTM-CAT300/600

4.3 Exhaust silencer(s)

	Pre-silencer	Main-silencer	Rear-silencer
Make:	KTM	---	KTM
Type (left/right):	--- / KTM VSD R2-02	--- / ---	--- / KTM 646 FD R2-01

4.3.1 Tail pipe(s)

Make: KTM
 Type (left/right): --- / without

4.3.2 Exhaust flap(s)

Make: ---
 Type (left/right): --- / ---

4.3.3 ECU exhaust flap(s)

Make: ---
 Type (left/right): ---

5. Tyres

	Axle 1	Axle 2
Manufacturer:	Pirelli	Pirelli
Type:	Scorpion Rally STR	Scorpion Rally STR
Size:	90/90-21 54V	150/70 R18 70V
Tyre pressure [bar]:	---	---
Tyre tread depth [mm]:	≥ 1,6	≥ 1,6



6. Measurements according to Annex 3

6.1 Conditions

Passby Parameter	
Ref. acc. $a_{wot\ ref}$ [m/s ²]:	3,76
-10% Ref. acc. $a_{wot\ ref\ min}$ [m/s ²]:	3,38
+10% Ref. acc. $a_{wot\ ref\ max}$ [m/s ²]:	4,14
Target acc. a_{urban} [m/s ²]:	1,85
Gear weighting factor k:	---
Partial power factor k_p :	0,48
Test speed v_{test} at PP' (± 1) [km/h]:	50,0

Driving Conditions	i	i+1
Gear:	4	---
test acc. $a_{wot\ test}$ [m/s ²]:	3,56	---
Ref. point at AA' [km/h]:	41,7	---
Ref. point at PP' [km/h]:	50,9	---
Ref. point at BB' [km/h]:	61,5	---
Operating mode:	Street	
Gearbox:	locked	

Calculation of the acceleration/factors
$a_{wot\ ref} = 3.33 * \log(PMR) - 4.16$
$k = n.a.$
$k_p = (1 - (a_{urban} / a_{wot\ test}))$
$a_{wot\ i} = ((v_{BB'}/3.6)^2 - (v_{AA'}/3.6)^2) / (2 * (20 + i))$
$a_{wot\ i+1} = n.a.$
$a_{urban} = 1.28 * \log(PMR) - 1.19$
Evaluation $a_{wot\ test}$: AA'-BB'

*aver. vehicle velocity when vehicle reference point

6.2 Measurement results pass by noise

Gear used	Run	Mode	acc. point ⁽¹⁾ [m]	A-A'		P-P'		B-B'		$a_{wot\ test}$ [m/s ²]	Sound level L ⁽²⁾		L _{aver} ⁽³⁾	
				v [km/h]	n [rpm]	v [km/h]	n [rpm]	v [km/h]	n [rpm]		left [dB(A)]	right [dB(A)]	li [dB(A)]	re [dB(A)]
4	14	wot ₍₄₎	-10,9	41,9	2410	51,0	2900	61,4	3516	3,50	81,7	82,9	81,8	82,9
	26			41,6	2329	50,7	2877	61,4	3513	3,54	81,6	83,0		
	27			41,6	2291	50,9	2878	61,8	3546	3,63	82,0	82,9		
	31	crs ₍₄₎	X	49,9	2804	49,8	2806	50,1	2819	X	71,4	72,1	71,1	71,7
	32			49,5	2776	49,8	2799	50,0	2796		71,7	71,8		
	33			50,6	2852	50,4	2813	50,2	2816		70,1	71,1		
-	---	wot ₍₋₎	---	---	---	---	---	---	---	---	---	---	---	---
	---			---	---	---	---	---	---	---	---	---	---	
	---			---	---	---	---	---	---	---	---	---	---	---
	---	crs ₍₋₎	X	---	---	---	---	---	---	X	---	---	---	---
	---			---	---	---	---	---	---		---			
	---			---	---	---	---	---	---		---			

1) Acceleration points according Line P-P'; 2) values reduced by 1 dB(A); Numbers written in italics a corrected acc. to Annex 3, Pt. 2.1; 3) Intermediate Results of each side of the vehicle

6.3 Results

	Gear		L _{rep}		L _{wot\ max\ limit} [dB(A)]	Test result L _{urban} [dB(A)]
	i [dB(A)]	i+1 [dB(A)]	wot [dB(A)]	crs [dB(A)]		
L _{wot}	82,9	---	82,9	71,7	82	77,5
L _{crs}	71,7	---				

Calculation L _{urban} (PMR > 25)
$[L_{urban} = L_{wot\ rep} - k_p * (L_{wot\ rep} - L_{crs\ rep})]$
$[L_{urban} = 82,9 - 0,48 * (82,9 - 71,7)]$

$[L_{wot\ rep} = L_{wot\ (i+1)} + k * (L_{wot\ (i)} - L_{wot\ (i+1)})]$; [In the case of a single gear ratio test the values are the test result of each test; PMR > 25]

$[L_{crs\ rep} = L_{crs\ (i+1)} + k * (L_{crs\ (i)} - L_{crs\ (i+1)})]$; [In the case of a single gear ratio test the values are the test result of each test; PMR > 25]

6.4 Limits

Category	Power-to-mass ratio index (PMR)	Limit value for L _{urban} [dB(A)]	applicable Limit value
First category	PMR ≤ 25	73	
Second category	25 < PMR ≤ 50	74	
Third category	PMR > 50	77 ^(a)	X

(a) For motorcycles tested in second gear only in Annex 3, the limit value is increased by 1dB(A) until the date in Paragraph 12.7. Data for affected vehicles shall be studied, and discussions shall be made in case of further extension.



6.5 Sound level of stationary vehicle

Measurement	Operation mode								Engine speed [min ⁻¹]	Target engine speed	
	Offroad		Street		Rain		---				
	left dB(A)	right dB(A)	left dB(A)	right dB(A)	left dB(A)	right dB(A)	left dB(A)	right dB(A)			
1 st Measurement	---	91,7	---	91,8	---	91,5	---	---	4125	n = 75% S (S ≤ 5000 min ⁻¹)	
2 nd Measurement	---	92,3	---	91,8	---	92,6	---	---			
3 rd Measurement	---	91,3	---	91,7	---	91,5	---	---		x	n = 50% S (S > 5000 min ⁻¹)
Interim result [dB(A)]	91,8		91,8		91,9		---				
Result [dB(A)]	92										

7. **Weather conditions**

Temperature Test Track [°C]:	23,8	Air Temperature [°C]:	7,1	Wind velocity [m/s]:	3,5
Humidity [%]:	35,9	Air pressure [hPa]:	999,8	Ambient noise [dB(A)]:	48,6

8. **Test Standard:** UN ECE-R 41.04, Supp.10, Annex 3

9. **Date / place of test:** 05.04.2023 / Prečna (SI)

10. **Date of issues:** 06.04.2023

11. **Remarks:** Vehicle had been tested in additional operation modes
 Different operation modes have no significant influence in sound pressure level L_{urban} , L_{stat} and acceleration $a_{wot\ test}$



Test chart 1

1. Vehicle

1.1	Manufacturer / VIN:	KTM / VBKTS3404PH700004
1.2	Commercial name / Type:	KTM 790 Adventure / KTM CV1 Adventure
1.3	Variant / Version:	A / ---
1.4	Vehicle class:	L3e-A3
1.5	Type approval number:	Prototype
1.6	Vehicle kerb weight (m_{kerb})[kg]:	218
1.7	Mass of the vehicle in running order (m_{ro}) [kg]:	293
1.8	Vehicle test mass (m_t with rider) [kg]:	287
1.9	Technically permissible max. laden mass (M) [kg]:	450
1.10	Power to mass ratio index (PMR):	238,9
1.11	Vehicle length [m]:	2,22
1.12	Mileage:	29

2. Engine

2.1	Manufacturer / Engine code:	KTM / P-A646*00001		
2.2	Cycles:	<input checked="" type="checkbox"/> four stroke	<input type="checkbox"/> two stroke	<input type="checkbox"/> n.a.
2.3	Number and arrangement of cylinders:	2 / In-Line		
2.4	Working principle:	<input checked="" type="checkbox"/> positive ignition	<input type="checkbox"/> compression ignition	<input type="checkbox"/> electric
2.5	Rated power [kW / min ⁻¹]:	70 / 8250		
2.6	Idle engine speed [min ⁻¹]:	1400		
2.7	Cylinder capacity [cm ³]	799		

3. Transmission

3.1	Type:	<input type="checkbox"/> automatic gearbox	<input checked="" type="checkbox"/> manual gearbox
3.2	Identifier:	---	
3.3	No. of gears:	6	
3.4	Final drive ratio (Prime:Secondary):	-/45	
3.5	Driving mode(s):	Street / Rain / Offroad	



4. Equipment

4.1 Pre Catalysator(s)

Make: ---
 Type (left/right): --- / ---

4.2 Catalysator(s)

Make: KTM
 Type (left/right): --- / KTM

4.3 Exhaust silencer(s)

	Pre-silencer	Main-silencer	Rear-silencer
Make:	KTM	---	Akrapovic
Type (left/right):	--- / KTM VSD R2-02	--- / ---	--- / M-HFT003

4.3.1 Tail pipe(s)

Make: Akrapovic
 Type (left/right): --- / D=35/40mm

4.3.2 Exhaust flap(s)

Make: ---
 Type (left/right): --- / ---

4.3.3 ECU exhaust flap(s)

Make: ---
 Type (left/right): ---

5. Tyres

	Axle 1	Axle 2
Manufacturer:	Pirelli	Pirelli
Type:	Scorpion Rally STR	Scorpion Rally STR
Size:	90/90-21 54V	150/70 R18 70V
Tyre pressure [bar]:	---	---
Tyre tread depth [mm]:	≥ 1,6	≥ 1,6



6. Measurements according to Annex 3

6.1 Conditions

Passby Parameter	
Ref. acc. $a_{wot\ ref}$ [m/s ²]:	3,76
-10% Ref. acc. $a_{wot\ ref\ min}$ [m/s ²]:	3,38
+10% Ref. acc. $a_{wot\ ref\ max}$ [m/s ²]:	4,14
Target acc. a_{urban} [m/s ²]:	1,85
Gear weighting factor k:	---
Partial power factor k_p :	0,46
Test speed v_{test} at PP' (± 1) [km/h]:	50,0

Driving Conditions	i	i+1
Gear:	4	---
test acc. $a_{wot\ test}$ [m/s ²]:	3,42	---
Ref. point at AA' [km/h]:	41,8	---
Ref. point at PP' [km/h]:	50,3	---
Ref. point at BB' [km/h]:	61,0	---
Operating mode:	STREET	
Gearbox:	locked	

Calculation of the acceleration/factors
$a_{wot\ ref} = 3.33 * \log(PMR) - 4.16$
$k = n.a.$
$k_p = (1 - (a_{urban} / a_{wot\ test}))$
$a_{wot\ i} = ((v_{BB'} / 3.6)^2 - (v_{AA'} / 3.6)^2) / (2 * (20 + i))$
$a_{wot\ i+1} = n.a.$
$a_{urban} = 1.28 * \log(PMR) - 1.19$
Evaluation $a_{wot\ test}$: AA'-BB'

*aver. vehicle velocity when vehicle reference point

6.2 Measurement results pass by noise

Gear used	Run	Mode	acc. point ⁽¹⁾ [m]	A-A'		P-P'		B-B'		$a_{wot\ test}$ [m/s ²]	Sound level L ⁽²⁾		L _{aver} ⁽³⁾	
				v [km/h]	n [rpm]	v [km/h]	n [rpm]	v [km/h]	n [rpm]		left [dB(A)]	right [dB(A)]	li [dB(A)]	re [dB(A)]
4	10	wot ₍₄₎	-10,7	41,5	2343	49,9	2857	60,9	3467	3,45	81,0	81,4	81,2	81,7
	19			42,3	2389	50,8	2921	61,3	3517	3,42	81,4	82,0		
	20			41,6	2263	50,1	2868	60,7	3489	3,39	81,2	81,8		
	23	crs ₍₄₎	X	49,9	2819	49,8	2811	50,5	2830	X	71,5	72,1	71,3	72,0
	24			49,8	2780	49,7	2781	50,0	2798		71,5	72,1		
	26			49,5	2772	49,6	2794	49,7	2783		71,0	71,9		
-	---	wot ₍₋₎	---	---	---	---	---	---	---	---	---	---	---	
	---			---	---	---	---	---	---	---	---			
	---			---	---	---	---	---	---	---	---			
	---	crs ₍₋₎	X	---	---	---	---	---	---	X	---	---	---	---
	---			---	---	---	---	---	---		---			
	---			---	---	---	---	---	---		---			

1) Acceleration points according Line P-P'; 2) values reduced by 1 dB(A); Numbers written in italics a corrected acc. to Annex 3, Pt. 2.1; 3) Intermediate Results of each side of the vehicle

6.3 Results

	Gear		L _{rep}		L _{wot\ max\ limit} [dB(A)]	Test result L _{urban} [dB(A)]
	i [dB(A)]	i+1 [dB(A)]	wot [dB(A)]	crs [dB(A)]		
L _{wot}	81,7	---	81,7	72,0	82	77,2
L _{crs}	72,0	---				

Calculation L _{urban} (PMR > 25)
$[L_{urban} = L_{wot\ rep} - k_p * (L_{wot\ rep} - L_{crs\ rep})]$
$[L_{urban} = 81,7 - 0,46 * (81,7 - 72,0)]$

$[L_{wot\ rep} = L_{wot\ (i+1)} + k * (L_{wot\ (i)} - L_{wot\ (i+1)})]$; [In the case of a single gear ratio test the values are the test result of each test; PMR > 25]

$[L_{crs\ rep} = L_{crs\ (i+1)} + k * (L_{crs\ (i)} - L_{crs\ (i+1)})]$; [In the case of a single gear ratio test the values are the test result of each test; PMR > 25]

6.4 Limits

Category	Power-to-mass ratio index (PMR)	Limit value for L _{urban} [dB(A)]	applicable Limit value
First category	PMR ≤ 25	73	
Second category	25 < PMR ≤ 50	74	
Third category	PMR > 50	77 ^(a)	X

(a) For motorcycles tested in second gear only in Annex 3, the limit value is increased by 1dB(A) until the date in Paragraph 12.7. Data for affected vehicles shall be studied, and discussions shall be made in case of further extension.



6.5 Sound level of stationary vehicle

Measurement	Operation mode								Engine speed [min ⁻¹]	Target engine speed	
	Offroad		Street		Rain		---				
	left dB(A)	right dB(A)	left dB(A)	right dB(A)	left dB(A)	right dB(A)	left dB(A)	right dB(A)			
1 st Measurement	---	89,2	---	88,3	---	88,6	---	---	4125	n = 75% S (S ≤ 5000 min ⁻¹)	
2 nd Measurement	---	88,7	---	88,2	---	89,0	---	---			
3 rd Measurement	---	89,3	---	88,4	---	89,7	---	---		x	n = 50% S (S > 5000 min ⁻¹)
Interim result [dB(A)]	89,1		88,3		89,1		---				
Result [dB(A)]	89										

7. **Weather conditions**

Temperature Test Track [°C]:	26,0	Air Temperature [°C]:	8,1	Wind velocity [m/s]:	4,7
Humidity [%]:	31,7	Air pressure [hPa]:	999,5	Ambient noise [dB(A)]:	48,5

8. **Test Standard:** UN ECE-R 41.04, Supp.10, Annex 3

9. **Date / place of test:** 05.04.2023 / Prečna (SI)

10. **Date of issues:** 06.04.2023

11. **Remarks:** Vehicle had been tested in additional operation modes
 Different operation modes have no significant influence in sound pressure level L_{urban} , L_{stat} and acceleration $a_{wot\ test}$
 Slip on System
 Inserts (tube in the tube) D=35mm / D=40mm



Laboratory Report

V00

Test standard:
UN-R 041

Level of amendment:
series of amendments 04, supplement 10

Title:
Noise of motor cycles

Manufacturer:
Akrapovič d.d.

Type:
M-HFT003

Subject of testing:
Component



0 General

- 0.1 Make (trade name of manufacturer): Akrapovič
- 0.2 Type: M-HFT003
- 0.2.1 Commercial description: M-HFT003
- 0.3 Means of identification of type, if marked on the vehicle: M-HFT003
- 0.3.1 Location of that marking: On exhaust
- 0.4 Category of vehicle: L3e
- 0.5 Manufacturer's name and address: Akrapovič d.d.
Malo Hudo 8a
1295 Ivancna Gorica (SI)
- 0.8 Name and address of assembly plant: Akrapovič d.d., PE Crnomelj
Ulica heroja Stariha 24
8340 Crnomelj (SI)
- 0.9 Name and address of representative: n.a.

1 Test conditions

Tests are carried out in compliance with the given requirements of the standard mentioned above.

- fulfilled
- not fulfilled



2 Attachments

2.1	Test report:	No.:	U1E70003-00
		Date of issue:	11.04.2023
2.2	Test report:	No.:	U1E70004-00
		Date of issue:	11.04.2023

3 Statement of conformity

The devices under test are in compliance with the test standard mentioned above.
 With regard to the required level of performance to be achieved, the test specimens were representative for the type.

The tests were carried out in accordance to the relevant requirements of the

EN ISO/IEC 17025 EN ISO/IEC 17020

**Test Laboratory
 SGS-TÜV Saar GmbH**

notified by

<p>KBA Krafftahrt-Bundes- amt, Germany No. KBA-P 00084-10</p>	<p>NSAI National Standards Authority of Ireland No. 101</p>	<p>RDW Rijksdienst voor het Wegverkeer, The Netherlands No. 99050064 00</p>	<p>TRANSPORT STYRELSEN, Sweden No. TT 0015</p>
--	---	--	--

**Formal review
 (conformity check)**

Signature



Gulnara Yodsangkam

Authorized by expert

Signature



Christoph Wibmer

Apr 12, 2023



This document shall be reproduced and published in full only and by the client only. It shall be reproduced partially with the written permission of the Test Laboratory only.

This document is issued by the Company subject to its General Conditions of Service (www.sgsgroup.de/agb). Attention is drawn to the limitations of liability, indemnification and jurisdictional issues established therein. This document is an original. If the document is submitted digitally, it is to be treated as an original within the meaning of UCP 600. Any holder of this document is advised that information contained hereon reflects the Company's findings at the time of its intervention only and within the limits of client's instructions, if any. The Company's sole responsibility is to its Client and this document does not exonerate parties to a transaction from exercising all their rights and obligations under the transaction documents. Any unauthorized alteration, forgery or falsification of the content or appearance of this document is unlawful and offenders may be prosecuted to the fullest extent of the law.

To assess the conformity, the laboratory refers to the "scope classification" of the Kraftfahrt-Bundesamt (KBA) – Federal Motor Transport Authority (in its valid version at the time of testing) and the specified consideration of the measurement uncertainty for the related test procedure.

In case the measurement uncertainty does not need to be considered according to the scope classification, the laboratory considers the result conform if its measured value is within the specification.

In case the measurement uncertainty does need to be considered according to the scope classification, the laboratory considers the result conform if its value incl. its measurement uncertainty is within the specification.

- End of Laboratory Report -

Test chart 1**1. Vehicle**

1.1	Manufacturer / VIN:	KTM / VBKTS6403MM813639
1.2	Commercial name / Type:	KTM 890 SMT / KTM R2 Adventure
1.3	Variant / Version:	D / ---
1.4	Vehicle class:	L3e-A3
1.5	Type approval number:	Prototype
1.6	Vehicle kerb weight (m_{kerb})[kg]:	206
1.7	Mass of the vehicle in running order (m_{ro}) [kg]:	281
1.8	Vehicle test mass (m_t with rider) [kg]:	274
1.9	Technically permissible max. laden mass (M) [kg]:	450
1.10	Power to mass ratio index (PMR):	274,0
1.11	Vehicle length [m]:	2,16
1.12	Mileage:	6093

2. Engine

2.1	Manufacturer / Engine code:	KTM / M-636*14745*		
2.2	Cycles:	<input checked="" type="checkbox"/> four stroke	<input type="checkbox"/> two stroke	<input type="checkbox"/> n.a.
2.3	Number and arrangement of cylinders:	2 / In-Line		
2.4	Working principle:	<input checked="" type="checkbox"/> positive ignition	<input type="checkbox"/> compression ignition	<input type="checkbox"/> electric
2.5	Rated power [kW / min ⁻¹]:	77 / 8000		
2.6	Idle engine speed [min ⁻¹]:	1400		
2.7	Cylinder capacity [cm ³]	889		

3. Transmission

3.1	Type:	<input type="checkbox"/> automatic gearbox	<input checked="" type="checkbox"/> manual gearbox
3.2	Identifier:	---	
3.3	No. of gears:	6	
3.4	Final drive ratio (Prime:Secondary):	---	
3.5	Driving mode(s):	Street / Sport / Rain	

4. Equipment

4.1 Pre Catalysator(s)

Make: ---
 Type (left/right): --- / ---

4.2 Catalysator(s)

Make: KTM
 Type (left/right): --- / KTM CAT 636.05.091.000

4.3 Exhaust silencer(s)

	Pre-silencer	Main-silencer	Rear-silencer
Make:	KTM	---	KTM
Type (left/right):	--- / KTM VSD R2-01	--- / ---	--- / KTM 635 ED R2-01

4.3.1 Tail pipe(s)

Make: KTM
 Type (left/right): --- / without

4.3.2 Exhaust flap(s)

Make: ---
 Type (left/right): --- / ---

4.3.3 ECU exhaust flap(s)

Make: ---
 Type (left/right): ---

5. Tyres

	Axle 1	Axle 2
Manufacturer:	Michelin	Michelin
Type:	Power GP	Power GP
Size:	120/70 ZR17 58W	180/55 ZR17 73W
Tyre pressure [bar]:	2,4	2,4
Tyre tread depth [mm]:	≥ 1,6	≥ 1,6



6. Measurements according to Annex 3

6.1 Conditions

Passby Parameter	
Ref. acc. $a_{wot\ ref}$ [m/s ²]:	3,96
-10% Ref. acc. $a_{wot\ ref\ min}$ [m/s ²]:	3,56
+10% Ref. acc. $a_{wot\ ref\ max}$ [m/s ²]:	4,36
Target acc. a_{urban} [m/s ²]:	1,93
Gear weighting factor k:	---
Partial power factor k_p :	0,52
Test speed v_{test} at PP' (± 1) [km/h]:	50,0

Driving Conditions	i	i+1
Gear:	4	---
test acc. $a_{wot\ test}$ [m/s ²]:	4,03	---
Ref. point at AA' [km/h]:	38,5	---
Ref. point at PP' [km/h]:	49,8	---
Ref. point at BB' [km/h]:	61,7	---
Operating mode:	STREET	
Gearbox:	locked	

Calculation of the acceleration/factors
$a_{wot\ ref} = 3.33 * \log(PMR) - 4.16$
$k = n.a.$
$k_p = (1 - (a_{urban} / a_{wot\ test}))$
$a_{wot\ i} = ((v_{BB'} / 3.6)^2 - (v_{AA'} / 3.6)^2) / (2 * (20 + i))$
$a_{wot\ i+1} = n.a.$
$a_{urban} = 1.28 * \log(PMR) - 1.19$
Evaluation $a_{wot\ test}$: AA'-BB'

*aver. vehicle velocity when vehicle reference point

6.2 Measurement results pass by noise

Gear used	Run	Mode	acc. point ⁽¹⁾ [m]	A-A'		P-P'		B-B'		$a_{wot\ test}$ [m/s ²]	Sound level L ⁽²⁾		L _{aver} ⁽³⁾	
				v [km/h]	n [rpm]	v [km/h]	n [rpm]	v [km/h]	n [rpm]		left [dB(A)]	right [dB(A)]	li [dB(A)]	re [dB(A)]
4	10	wot ₍₄₎	-10,6	38,8	2096	50,1	2798	62,0	3522	4,07	81,9	82,3	82,1	82,2
	11			38,3	2082	49,6	2812	61,6	3482	4,05	82,0	82,3		
	12			38,5	2141	49,7	2791	61,4	3462	3,98	82,3	82,1		
	26	crs ₍₄₎	X	50,1	2799	49,6	2772	50,1	2797	X	72,0	73,0	71,6	72,1
	27			50,3	2837	50,7	2799	50,1	2819		71,4	72,0		
	28			50,3	2810	50,2	2801	49,5	2781		71,3	71,3		
-	---	wot ₍₋₎	---	---	---	---	---	---	---	---	---	---	---	---
	---			---	---	---	---	---	---	---	---	---	---	
	---			---	---	---	---	---	---	---	---	---	---	---
	---	crs ₍₋₎	X	---	---	---	---	---	---	X	---	---	---	---
	---			---	---	---	---	---	---		---			
	---			---	---	---	---	---	---		---			

1) Acceleration points according to Line P-P'; 2) values reduced by 1 dB(A); Numbers written in italics a corrected acc. to Annex 3, Pt. 2.1; 3) Intermediate Results of each side of the vehicle

6.3 Results

	Gear		L _{rep}		L _{wot\ max\ limit} [dB(A)]	Test result L _{urban} [dB(A)]
	i [dB(A)]	i+1 [dB(A)]	wot [dB(A)]	crs [dB(A)]		
L _{wot}	82,2	---	82,2	72,1	82	76,9
L _{crs}	72,1	---				

Calculation L _{urban} (PMR > 25)
$[L_{urban} = L_{wot\ rep} - k_p * (L_{wot\ rep} - L_{crs\ rep})]$
$[L_{urban} = 82,2 - 0,52 * (82,2 - 72,1)]$

$[L_{wot\ rep} = L_{wot\ (i+1)} + k * (L_{wot\ (i)} - L_{wot\ (i+1)})]$; [In the case of a single gear ratio test the values are the test result of each test; PMR > 25]

$[L_{crs\ rep} = L_{crs\ (i+1)} + k * (L_{crs\ (i)} - L_{crs\ (i+1)})]$; [In the case of a single gear ratio test the values are the test result of each test; PMR > 25]

6.4 Limits

Category	Power-to-mass ratio index (PMR)	Limit value for L _{urban} [dB(A)]	applicable Limit value
First category	PMR ≤ 25	73	
Second category	25 < PMR ≤ 50	74	
Third category	PMR > 50	77 ^(a)	X

(a) For motorcycles tested in second gear only in Annex 3, the limit value is increased by 1dB(A) until the date in Paragraph 12.7. Data for affected vehicles shall be studied, and discussions shall be made in case of further extension.



6.5 Sound level of stationary vehicle

Measurement	Operation mode								Engine speed [min ⁻¹]	Target engine speed	
	Sport		Street		Rain		---				
	left dB(A)	right dB(A)	left dB(A)	right dB(A)	left dB(A)	right dB(A)	left dB(A)	right dB(A)			
1 st Measurement	---	89,3	---	89,2	---	88,8	---	---	4000	n = 75% S (S ≤ 5000 min ⁻¹)	
2 nd Measurement	---	89,3	---	89,7	---	88,7	---	---			
3 rd Measurement	---	90,0	---	89,1	---	89,1	---	---		x	n = 50% S (S > 5000 min ⁻¹)
Interim result [dB(A)]	89,5		89,3		88,9		---				
Result [dB(A)]	90										

7. **Weather conditions**

Temperature Test Track [°C]:	26,1	Air Temperature [°C]:	8,9	Wind velocity [m/s]:	4,5
Humidity [%]:	28,7	Air pressure [hPa]:	998,9	Ambient noise [dB(A)]:	49,1

8. **Test Standard:** UN ECE-R 41.04, Supp.10, Annex 3

9. **Date / place of test:** 05.04.2023 / Prečna (SI)

10. **Date of issues:** 11.04.2023

11. **Remarks:** Vehicle had been tested in additional operation modes
 Different operation modes have no significant influence in sound pressure level L_{urban} , L_{stat} and acceleration $a_{wot\ test}$



Test chart 1

1. Vehicle

1.1	Manufacturer / VIN:	KTM / VBKTS6403MM813639
1.2	Commercial name / Type:	KTM 890 SMT / KTM R2 Adventure
1.3	Variant / Version:	D / ---
1.4	Vehicle class:	L3e-A3
1.5	Type approval number:	Prototype
1.6	Vehicle kerb weight (m_{kerb})[kg]:	206
1.7	Mass of the vehicle in running order (m_{ro}) [kg]:	281
1.8	Vehicle test mass (m_t with rider) [kg]:	274
1.9	Technically permissible max. laden mass (M) [kg]:	450
1.10	Power to mass ratio index (PMR):	274,0
1.11	Vehicle length [m]:	2,16
1.12	Mileage:	6093

2. Engine

2.1	Manufacturer / Engine code:	KTM / M-636*14745*		
2.2	Cycles:	<input checked="" type="checkbox"/> four stroke	<input type="checkbox"/> two stroke	<input type="checkbox"/> n.a.
2.3	Number and arrangement of cylinders:	2 / In-Line		
2.4	Working principle:	<input checked="" type="checkbox"/> positive ignition	<input type="checkbox"/> compression ignition	<input type="checkbox"/> electric
2.5	Rated power [kW / min ⁻¹]:	77 / 8000		
2.6	Idle engine speed [min ⁻¹]:	1400		
2.7	Cylinder capacity [cm ³]	889		

3. Transmission

3.1	Type:	<input type="checkbox"/> automatic gearbox	<input checked="" type="checkbox"/> manual gearbox
3.2	Identifier:	---	
3.3	No. of gears:	6	
3.4	Final drive ratio (Prime:Secondary):	---	
3.5	Driving mode(s):	Street / Sport / Rain	



4. Equipment

4.1 Pre Catalysator(s)

Make: ---
 Type (left/right): --- / ---

4.2 Catalysator(s)

Make: KTM
 Type (left/right): --- / CAT 636.05.091.000

4.3 Exhaust silencer(s)

	Pre-silencer	Main-silencer	Rear-silencer
Make:	KTM	---	Akrapovic
Type (left/right):	--- / KTM VSD R2-01	--- / ---	--- / M-HFT003

4.3.1 Tail pipe(s)

Make: Akrapovic
 Type (left/right): --- / D=35/40mm

4.3.2 Exhaust flap(s)

Make: ---
 Type (left/right): --- / ---

4.3.3 ECU exhaust flap(s)

Make: ---
 Type (left/right): ---

5. Tyres

	Axle 1	Axle 2
Manufacturer:	Michelin	Michelin
Type:	Power GP	Power GP
Size:	120/70 ZR17 58W	180/55 ZR17 73W
Tyre pressure [bar]:	2,4	2,4
Tyre tread depth [mm]:	≥ 1,6	≥ 1,6



6. Measurements according to Annex 3

6.1 Conditions

Passby Parameter	
Ref. acc. $a_{wot\ ref}$ [m/s ²]:	3,96
-10% Ref. acc. $a_{wot\ ref\ min}$ [m/s ²]:	3,56
+10% Ref. acc. $a_{wot\ ref\ max}$ [m/s ²]:	4,36
Target acc. a_{urban} [m/s ²]:	1,93
Gear weighting factor k:	---
Partial power factor k_p :	0,54
Test speed v_{test} at PP' (± 1) [km/h]:	50,0

Driving Conditions	i	i+1
Gear:	4	---
test acc. $a_{wot\ test}$ [m/s ²]:	4,18	---
Ref. point at AA' [km/h]:	38,6	---
Ref. point at PP' [km/h]:	49,8	---
Ref. point at BB' [km/h]:	62,4	---
Operating mode:	Street	
Gearbox:	locked	

Calculation of the acceleration/factors
$a_{wot\ ref} = 3.33 * \log(PMR) - 4.16$
$k = n.a.$
$k_p = (1 - (a_{urban} / a_{wot\ test}))$
$a_{wot\ i} = ((v_{BB'} / 3.6)^2 - (v_{AA'} / 3.6)^2) / (2 * (20 + i))$
$a_{wot\ i+1} = n.a.$
$a_{urban} = 1.28 * \log(PMR) - 1.19$
Evaluation $a_{wot\ test}$: AA'-BB'

*aver. vehicle velocity when vehicle reference point

6.2 Measurement results pass by noise

Gear used	Run	Mode	acc. point ⁽¹⁾ [m]	A-A'		P-P'		B-B'		$a_{wot\ test}$ [m/s ²]	Sound level L ⁽²⁾		L _{aver} ⁽³⁾	
				v [km/h]	n [rpm]	v [km/h]	n [rpm]	v [km/h]	n [rpm]		left [dB(A)]	right [dB(A)]	li [dB(A)]	re [dB(A)]
4	1	wot ₍₄₎	-10,6	39,1	2148	50,0	2851	62,6	3518	4,16	81,0	81,9	81,4	81,9
	2			38,5	2113	49,9	2810	62,4	3503	4,20	81,6	81,8		
	5			38,3	2093	49,6	2786	62,2	3488	4,18	81,5	82,1		
	8	crs ₍₄₎	X	50,0	2786	49,6	2795	50,0	2775	X	73,4	73,2	72,6	72,7
	9			49,8	2762	49,5	2793	49,4	2786		72,6	72,5		
	10			49,5	2798	50,1	2802	49,9	2786		71,9	72,4		
-	---	wot ₍₋₎	---	---	---	---	---	---	---	---	---	---	---	---
	---			---	---	---	---	---	---	---	---	---	---	
	---			---	---	---	---	---	---	---	---	---	---	---
	---	crs ₍₋₎	X	---	---	---	---	---	---	X	---	---	---	---
	---			---	---	---	---	---	---		---			
	---			---	---	---	---	---	---		---			

1) Acceleration points according to Line P-P'; 2) values reduced by 1 dB(A); Numbers written in italics a corrected acc. to Annex 3, Pt. 2.1; 3) Intermediate Results of each side of the vehicle

6.3 Results

	Gear		L _{rep}		L _{wot\ max\ limit} [dB(A)]	Test result L _{urban} [dB(A)]
	i [dB(A)]	i+1 [dB(A)]	wot [dB(A)]	crs [dB(A)]		
L _{wot}	81,9	---	81,9	72,7	82	77,0
L _{crs}	72,7	---				

Calculation L _{urban} (PMR > 25)
$[L_{urban} = L_{wot\ rep} - k_p * (L_{wot\ rep} - L_{crs\ rep})]$
$[L_{urban} = 81,9 - 0,54 * (81,9 - 72,7)]$

$[L_{wot\ rep} = L_{wot\ (i+1)} + k * (L_{wot\ (i)} - L_{wot\ (i+1)})]$; [In the case of a single gear ratio test the values are the test result of each test; PMR > 25]

$[L_{crs\ rep} = L_{crs\ (i+1)} + k * (L_{crs\ (i)} - L_{crs\ (i+1)})]$; [In the case of a single gear ratio test the values are the test result of each test; PMR > 25]

6.4 Limits

Category	Power-to-mass ratio index (PMR)	Limit value for L _{urban} [dB(A)]	applicable Limit value
First category	PMR ≤ 25	73	
Second category	25 < PMR ≤ 50	74	
Third category	PMR > 50	77 ^(a)	X

(a) For motorcycles tested in second gear only in Annex 3, the limit value is increased by 1dB(A) until the date in Paragraph 12.7. Data for affected vehicles shall be studied, and discussions shall be made in case of further extension.



6.5 Sound level of stationary vehicle

Measurement	Operation mode								Engine speed [min ⁻¹]	Target engine speed	
	Rain		Street		Sport		---				
	left dB(A)	right dB(A)	left dB(A)	right dB(A)	left dB(A)	right dB(A)	left dB(A)	right dB(A)			
1 st Measurement	---	89,1	---	88,9	---	88,7	---	---	4000	x	n = 75% S (S ≤ 5000 min ⁻¹)
2 nd Measurement	---	88,9	---	88,8	---	88,8	---	---			n = 50% S (S > 5000 min ⁻¹)
3 rd Measurement	---	88,9	---	88,8	---	89,0	---	---			
Interim result [dB(A)]	89,0		88,8		88,8		---				
Result [dB(A)]	89										

7. **Weather conditions**

Temperature Test Track [°C]:	25,0	Air Temperature [°C]:	8,9	Wind velocity [m/s]:	3,9
Humidity [%]:	29,2	Air pressure [hPa]:	998,7	Ambient noise [dB(A)]:	40,7

8. **Test Standard:** UN ECE-R 41.04, Supp.10, Annex 3

9. **Date / place of test:** 05.04.2023 / Prečna (SI)

10. **Date of issues:** 11.04.2023

11. **Remarks:** Vehicle had been tested in additional operation modes
 Different operation modes have no significant influence in sound pressure level L_{urban} , L_{stat} and acceleration $a_{wot\ test}$
 Slip on system
 Inserts (tube in the tube) D=35mm / D=40mm



Item No.	(Sub) categories	Detailed information
B.		General information concerning systems, components, or separate technical units
0.7.	L1e — L7e	Make(s) (trade name(s) of manufacturer): AKRAPOVIC Exhaust System Technology
0.8.	L1e — L7e	Type: M-HFT003
0.8.1.	L1e — L7e	Commercial name(s) (if available): n.a.
0.8.2.	L1e — L7e	Type-approval number(s) (if available): e26*134/2014*2018/295G*08157*03
0.8.3.	L1e — L7e	Type-approval(s) issued on (date, if available): n.a.
0.9.	L1e — L7e	Company name and address of manufacturer: Akrapovic d.d. Malo Hudo 8a 1295 Ivancna Gorica Slovenia
0.9.1.	L1e — L7e	Name(s) and address(es) of assembly plants: n.a.
0.9.2.	L1e — L7e	Name and address of manufacturer's authorized representative, if any: n.a.
0.10.		Vehicle(s) for which the system/separate technical unit is intended for:
0.10.1.	L1e — L7e	Type: see Technical Report
0.10.2.	L1e — L7e	Variant: see Technical Report
0.10.3.	L1e — L7e	Version: see Technical Report
0.10.4.	L1e — L7e	Commercial name(s) (if available): see Technical Report
0.10.5.	L1e — L7e	Category, subcategory and sub-subcategory of vehicle: see Technical Report
C.		General information concerning vehicle, systems, components or separate technical units
0.12.		Conformity of production
0.12.1.	L1e — L7e	Controlled by ISO 9001:2008 Quality Management System certified by TÜV SÜD Management Service GmbH Registration no.: 12 100/104 31148 TMS
1.		GENERAL CONSTRUCTION CHARACTERISTICS
1.8.		Propulsion unit performance
1.8.1.	L3e, L4e, L5e, L7e-A, L7e-B2	Declared maximum vehicle speed: km/h see Technical Report
1.8.2.	L1e, L2e, L6e, L7e-B1, L7e-C	Maximum design vehicle speed: and gear in which it is reached: n.a.
1.8.3.	L1e — L7e	Maximum net power combustion engine: . kW at . min ⁻¹ at A/F ratio: see Technical Report
1.8.4.	L1e — L7e	Maximum net torque combustion engine: . Nm at . min ⁻¹ at A/F ratio: see Technical Report
1.8.5.	L1e — L7e	Maximum continuous-rated power electric motor (15/30 minutes power): n.a.
1.8.6.	L1e — L7e	Maximum continuous-rated torque electric motor: Nm at min ⁻¹ n.a.
1.8.7.	L1e — L7e	Maximum continuous total power for propulsion(s): kW. at ... min ⁻¹ at A/F ratio: n.a.
1.8.8.	L1e — L7e	Maximum continuous total torque for propulsion(s): Nm at min ⁻¹ at A/F ratio: n.a.
1.8.9.	L1e — L7e	Maximum peak power for propulsion(s): kW at min ⁻¹ at A/F ratio: n.a.
4.		GENERAL INFORMATION ON ENVIRONMENTAL AND PROPULSION UNIT PERFORMANCE
4.0		General information on environmental and propulsion performance
4.0.1.	L1e — L7e	Environmental step: Euro (4/5)
4.0.2.	L1e — L7e	Fuel consumption: see WVTA
4.0.3.	L1e — L7e	CO ₂ emissions: see WVTA
4.0.4.	L1e — L7e	Energy consumption: n.a.
4.0.5.	L1e — L7e	Electric range: n.a.
4.0.6.		Sound level
4.0.6.1.	L1e — L7e	Limit value for L _{urban} : see Technical Report
4.4.	L1e — L7e	Additional information on environmental and propulsion unit performance
4.4.4.	L1e — L7e	All additional technical information according to UN Regulation No. 92, are mentioned in the Technical Report or shown in the attachments.



Information Document M-HFT003

relating to EU type-approval of a noise-abatement device as a STU

TÜV SÜD Auto Service Technical Report: 20-00040-CM-GBM-03

Anlage / Enclosure	Dokument-Nr. / Document no.	Datum / Date	Seiten / Pages
Zeichnung Gesamtanlage / Drawing exhaust system	KTM Adventure 890	-	1
ASEP Erklärung / ASEP Statement	-	06.04.2023	1

AKRPOVIČ, d.d.
ul. Na, 1295 Ivančna Gorica,
Slovenija

Davorin Dobočnik, CEO

24.04.2023



KTM Adventure 890/Adventure 790/Adventure 790R/Adventure 890R/SMT 890
Husqvarna Norden 901/Expedition
Partial exhaust system / Slip-ON line / EC/ECE Type approval
Product code: S-KTM8S02-HFTT

M-HFT003
e26*08157*G
E26 92R-02 8157

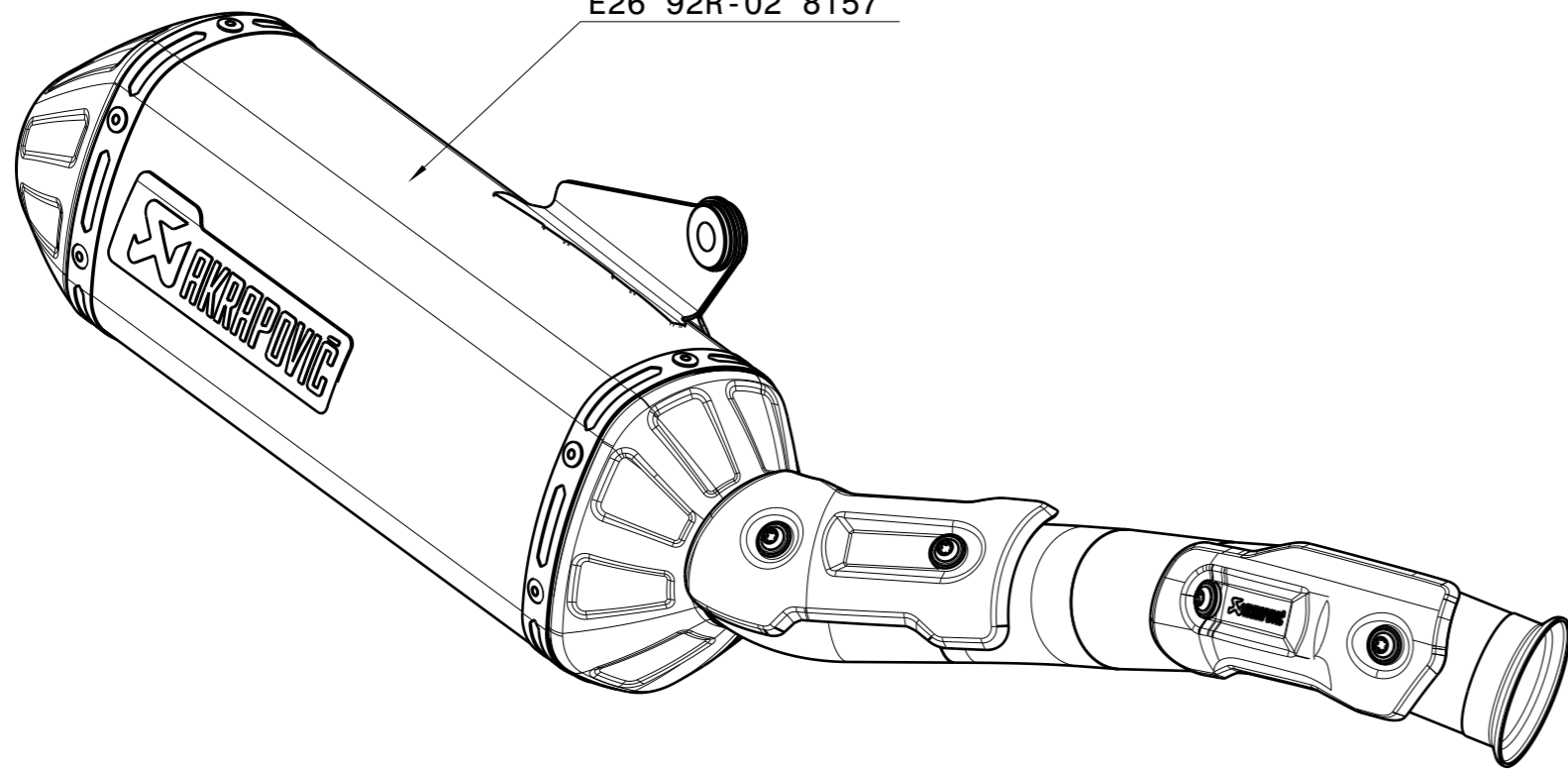

Original parts

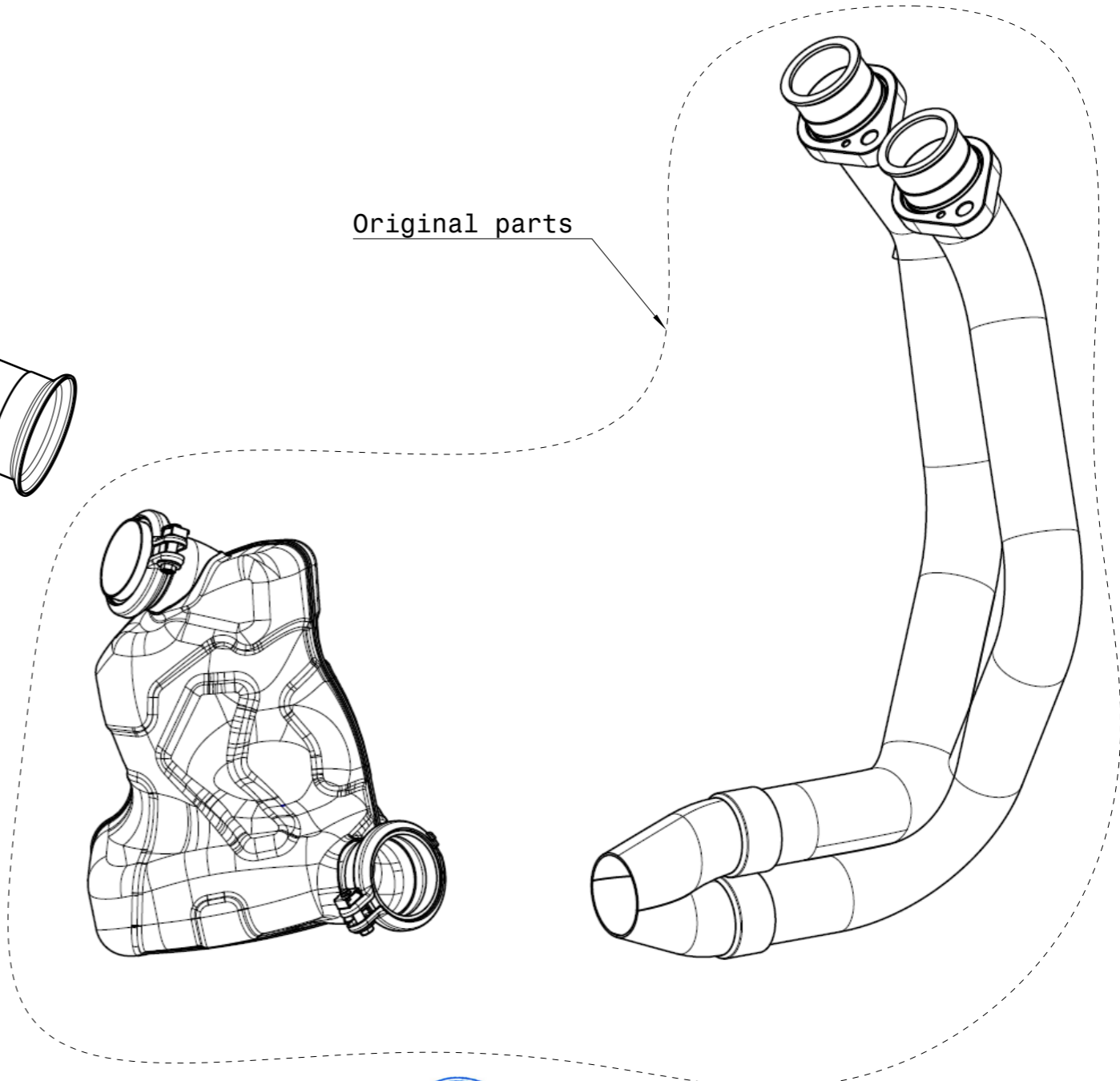

Statement of compliance with the Additional Sound Emission Provisions

This statement is required for non-original replacement exhaust silencing systems (NORESS) without multiple, manually or electronically adjustable, rider selectable operating modes or without variable geometries specified for the use on L3 Category vehicles that are type approved pursuant to the amendments to UN Regulation No.41 and are subject to the ASEP-requirements series of amendments to UN Regulation No.41.

Akrapovič d.d., Malo Hudo 8a, 1295 Ivančna Gorica, attests that the non-original replacement exhaust silencing systems of this type **M-HFT003, (E26 92R-02 8157)**, comply with the applicable ASEP requirements of UN Regulation No.41 during the type approval procedure and its production.

Akrapovič d.d., Malo Hudo 8a, 1295 Ivančna Gorica, makes this statement in good faith, after having performed an appropriate evaluation of the sound emission performance of the non-original replacement exhaust silencing system in accordance with the requirements of UN Regulation No.92 during the type approval procedure and its production.

Date: 06.04.2023

Akrapovič d.d.
Davorin Dobočnik, CEO

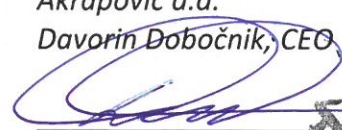

 **AKRAPOVIČ** d.d.
Malo Hudo 8a, 1295 Ivančna Gorica
Slovenija

