

# 150 SX 2017

ART.-NR.: 3CM081530QEN

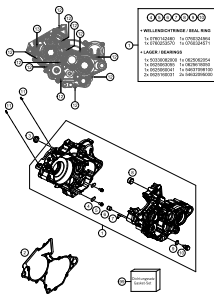

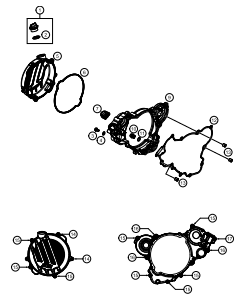
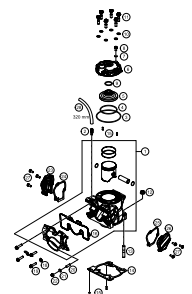
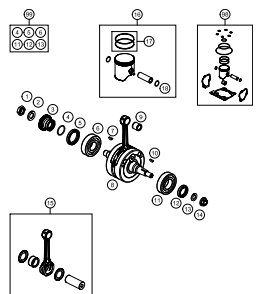
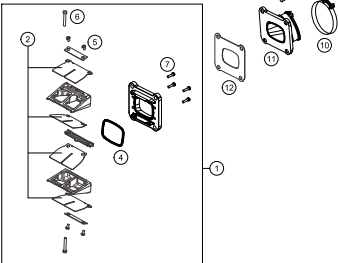
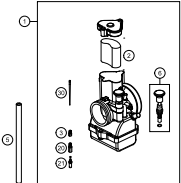
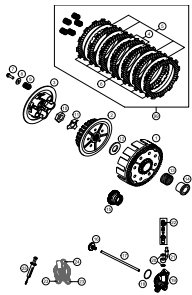
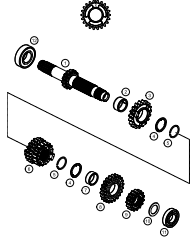
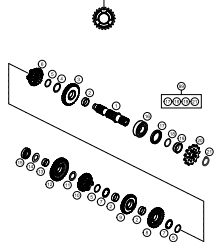
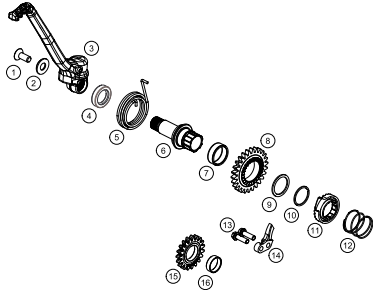
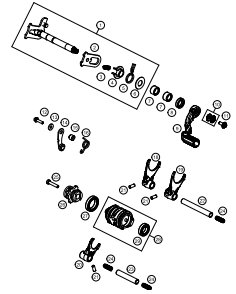
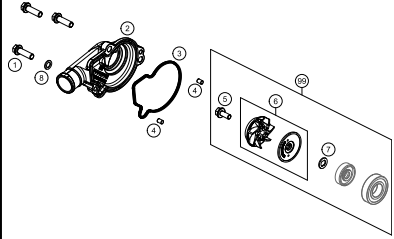

<p><b>ENGINE CASE</b></p>  <p><b>3</b></p>	<p><b>CLUTCH COVER</b></p>  <p><b>4</b></p>	<p><b>CYLINDER, CYLINDER HEAD</b></p>  <p><b>5</b></p>	<p><b>CRANKSHAFT, PISTON</b></p>  <p><b>6</b></p>
<p><b>REED VALVE CASE</b></p>  <p><b>7</b></p>	<p><b>8</b></p> <p> <small>ACHTUNG !!!</small> Vor dem Einbau des Vergasers die Bedüsung kontrollieren. <small>CAUTION !!!</small> Before mounting the carburetor, check the jetting.         </p> 	<p><b>CLUTCH</b></p>  <p><b>10</b></p>	<p><b>TRANSMISSION I - MAIN SHAFT</b></p> <p> <small>ACHTUNG !!!</small> Bei Montage von Gegenrädern, Montage beachten. <small>CAUTION !!!</small> When installing transmission gears, check timing.         </p>  <p><b>11</b></p>
<p><b>TRANSMISSION II - COUNTERSHAFT</b></p> <p> <small>ACHTUNG !!!</small> Bei Montage von Gegenrädern, Montage beachten. <small>CAUTION !!!</small> When installing transmission gears, check timing.         </p>  <p><b>12</b></p>	<p><b>KICK STARTER</b></p>  <p><b>13</b></p>	<p><b>SHIFTING MECHANISM</b></p>  <p><b>14</b></p>	<p><b>WATERPUMP</b></p>  <p><b>15</b></p>

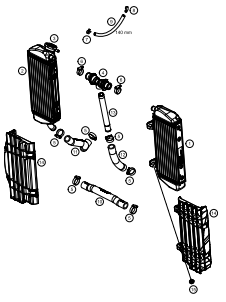
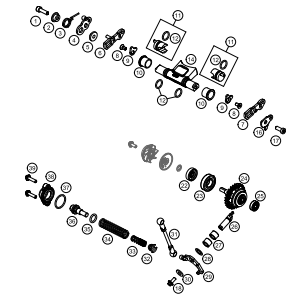
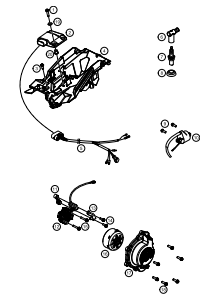
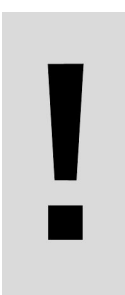
<p><b>COOLING SYSTEM</b></p>  <p style="text-align: right;"><b>16</b></p>	<p><b>EXHAUST CONTROL</b></p>  <p style="text-align: right;"><b>17</b></p>	<p><b>IGNITION SYSTEM</b></p>  <p style="text-align: right;"><b>18</b></p>	
	<div style="display: flex; align-items: center;">  <p>                     All information contained is without obligation. KTM Sportmotorcycle GmbH particularly reserves the right to modify any equipment, technical specifications, prices, colors, shapes, materials, services, service work, constructions, equipment and the like so as to adapt them to local conditions or to cancel any of the above items, all without previous announcement and without giving reasons. KTM may stop manufacturing certain models without previous notice. KTM shall not be held liable for any deviations of availability and/or ability to deliver, illustrations, descriptions, printing and/or other errors. The illustrated models partly contain extra equipment, which is not applied to standard models.                       © by KTM Sportmotorcycle GmbH, Mattighofen AUSTRIA; All rights reserved; Reprint, also in extracts, with written allowance of KTM Sportmotorcycle GmbH, Mattighofen only.                 </p> </div>		

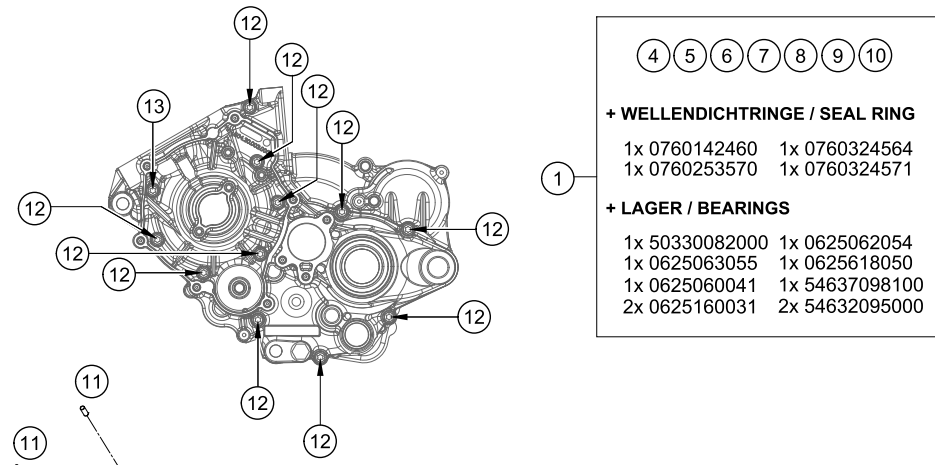

- 4 5 6 7 8 9 10
- + WELLENDICHTRINGE / SEAL RING**  
 1x 0760142460 1x 0760324564  
 1x 0760253570 1x 0760324571
- + LAGER / BEARINGS**  
 1x 50330082000 1x 0625062054  
 1x 0625063055 1x 0625618050  
 1x 0625060041 1x 54637098100  
 2x 0625160031 2x 54632095000

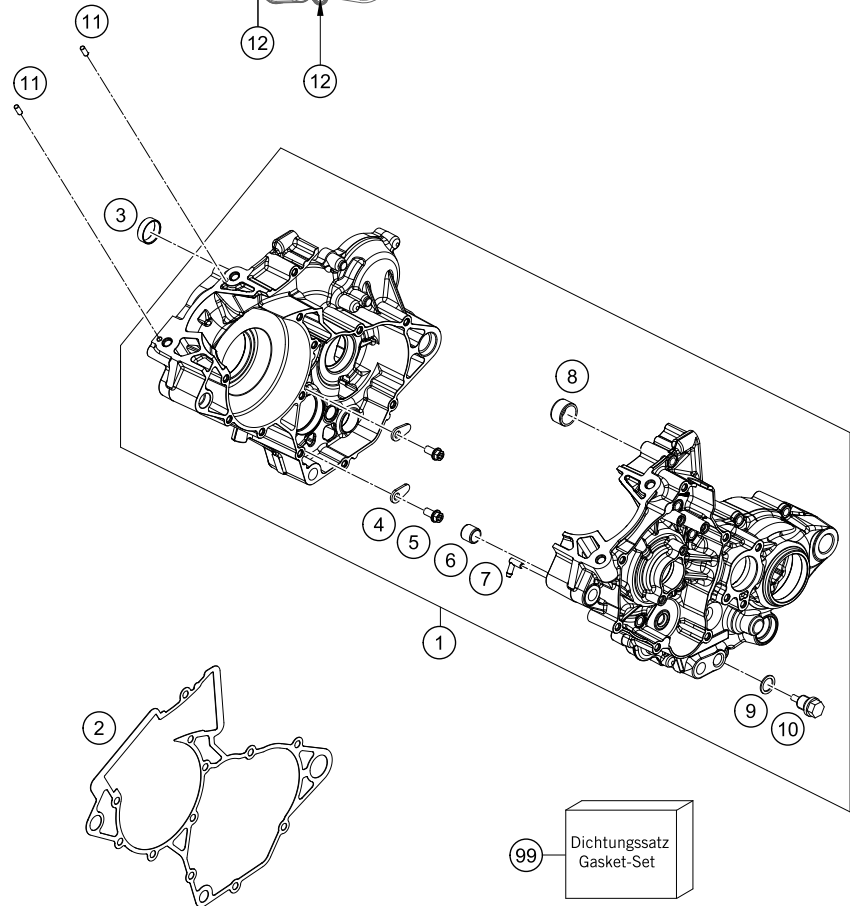

99 Dichtungssatz  
Gasket-Set

165043010

POS	PARTNUMBER	PARTNAME	PIECE
1	50430000033	ENGINECASE CPL.	1
2	50430039000	GASKET ENGINE CASE	1
3	50433024050	BUSHING IDLER GEAR	1
4	54634049000	RETAINING PLATE	2
5	0025060126	HH COLLAR SCREW M6X12 TX30	2
6	54630027000	DOWEL BUSHING 13,8X11X12	1
7	45130022000	ANGLE PIECE 50CCM LC 2001	1
8	54830027000	DOWEL 21X12 03	1
9	58038022000	CU-SEAL RING DIN7603-12X18X1,5	1
10	58030021000	OILDRAIN PLUG W.MAG. M 12X1,5	1
11	0402040980	NEEDLE ROL.DIN5402 NRB 4X9,8	2
12	0025060506	HH COLLAR SCREW M6X50 TX30	11
13	0025060606	HH COLLAR SCREW M6X60 TX30	1
99	50430099000	GASKET SET ENGINE 125/150	x

C165043010

\* NEW PART

X ON DEMAND

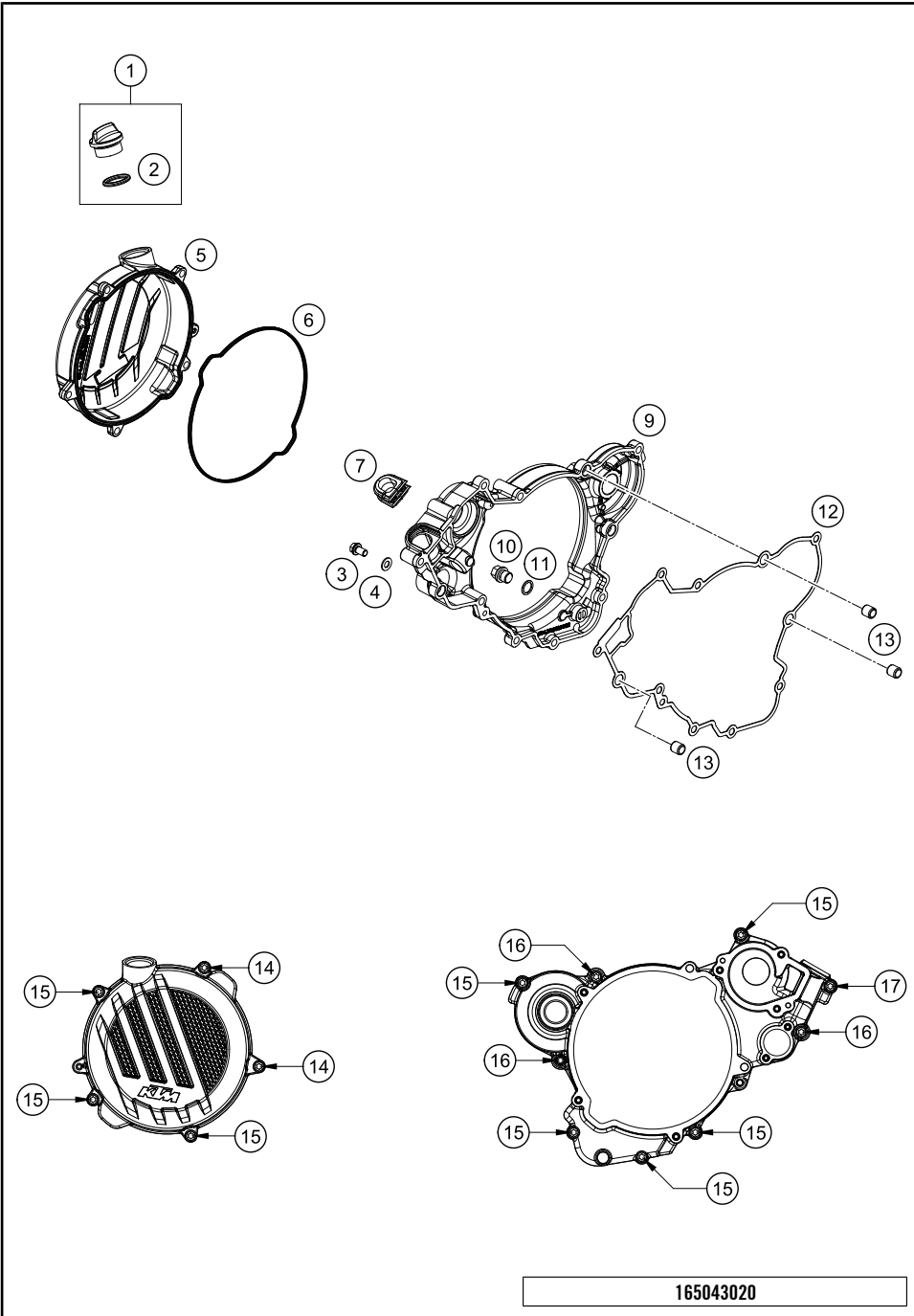

POS	PARTNUMBER	PARTNAME	PIECE
1	79430020033	OIL FILLER CAP M24x3 WITH O-R	1
2	0770191015	O-RING 19,00X3,00 NBR	1
3	0025060106	HH COLLAR SCREW M6X10 TX30	1
4	0603061001	CU-SEAL RING DIN7603-6X10X1	1
5	5043002600015	OUTER CLUTCH COVER	1
6	50430027000	GASKET OUTER CLUTCH COVER	1
7	50437091000	SEALING ELEMENT	1
9	50430001044	INNER CLUTCH COVER CPL.	1
10	0910100003	PLUG DIN0910-M 10X1	1
11	0603100141	COPPER GASKET DIN7603-10X14X1	1
12	50430025000	GASKET INNER CLUTCH COVER	1
13	49030090000	DOWEL 9,8 X 7 X 10	3
14	0025060506	HH COLLAR SCREW M6X50 TX30	2
15	0025060206	HH COLLAR SCREW M6X20 TX30	8
16	0025060256	HH COLLAR SCREW M6X25 TX30	3
17	0025060306	HH COLLAR SCREW M6X30 TX30	1

165043020

C165043020

\* NEW PART X ON DEMAND

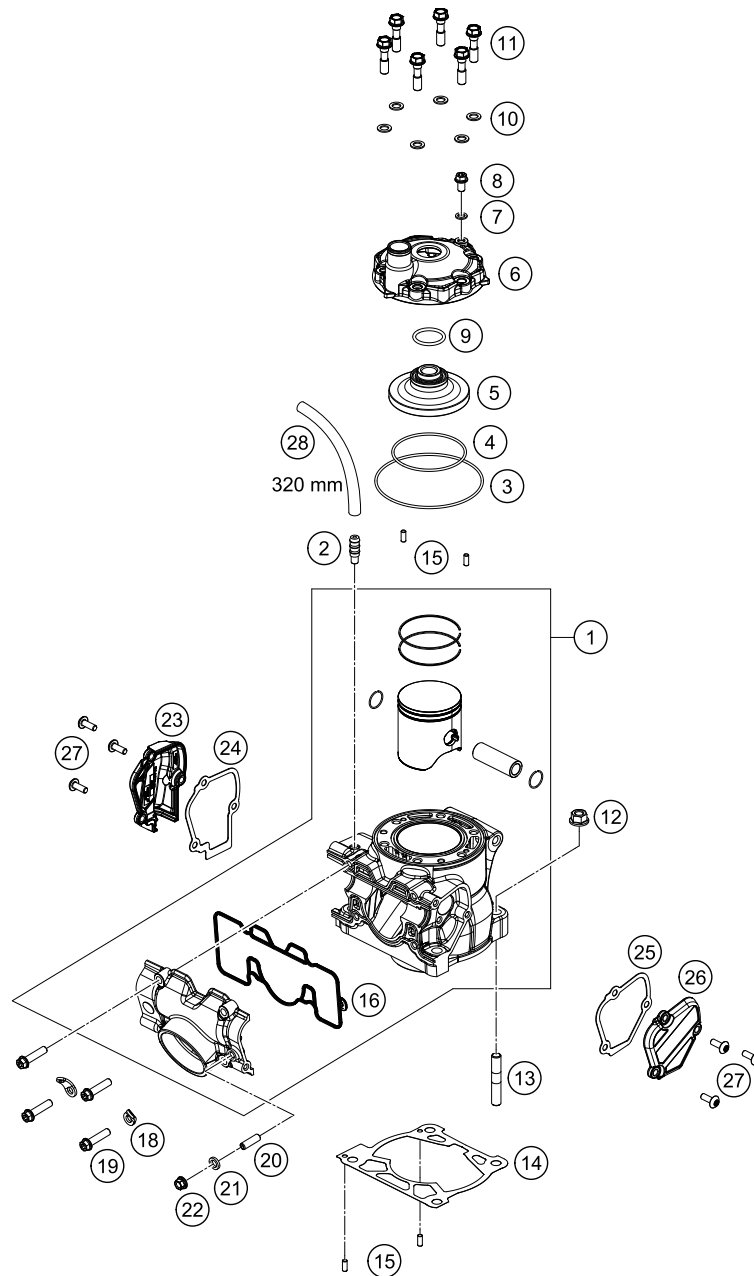

165043050

POS	PARTNUMBER	PARTNAME	PIECE
1	51630038000	CYLINDER + PISTON CPL. 150	1
2	58336020090	VACUUM CONNECTION M 6X1	1
3	0770890200	O-RING 89X2 NBR 70 SH	1
4	0770640200	O-RING 64X2 FPM 80SH	1
5	51630060000	COMBUSTION CHAMBER INLAY	1
6*	51630106000	CYLINDER HEAD	1
7	0603061001	CU-SEAL RING DIN7603-6X10X1	1
8	0025060106	HH COLLAR SCREW M6X10 TX30	1
9	07702300251	O-RING 23,00X2,5 NBR 70 SH	1
10	0603070121	CU-SEAL RING DIN7603- 7,3X12X1	6
11	50430079000	CYLINDER HEAD SCREW	6
12	50330045000	HH COLLAR NUT M 8 WS=12	4
13	0835080326	STUD DIN 835 M8X32	4
14	50430035015	CYLINDER BASE GASKET 0.15MM	x
14	50430035020	CYLINDER BASE GASKET 0.20MM	x
14	50430035025	CYLINDER BASE GASKET 0.25MM	x
14	50430035040	CYLINDER BASE GASKET 0.40MM	x
14	50430035050	CYLINDER BASE GASKET 0.50MM	x
14	50430035075	CYLINDER BASE GASKET 0.75MM	x
15	0402040980	NEEDLE ROL.DIN5402 NRB 4X9,8	4
16	50437046000	GASKET CONNECTION FLANGE	1
18	51005074000	RETAINING PLATE	2
19	0025060256	HH COLLAR SCREW M6X25 TX30	4
20	0913060203	THREAD PIN DIN0913-M 6X20	1
21	0603061001	CU-SEAL RING DIN7603-6X10X1	1
22	77336088106	COLLAR NUT M6X1 SW8	1
23	5043700700033	EXHAUST CONTROL COVER R/S	1
24	50437008000	GASKET EXH. CONTROL COVER R/S	1
25	50437006000	GASKET EXH. CONTROL COVER L/S	1
26	5043700500033	EXHAUST CONTROL COVER L/S	1
27	58605083014	SCREW M5X14 TORX 25 07	6
28	50335030001	PVC-HOSE 6X9	x

C175163050

\* NEW PART

X ON DEMAND

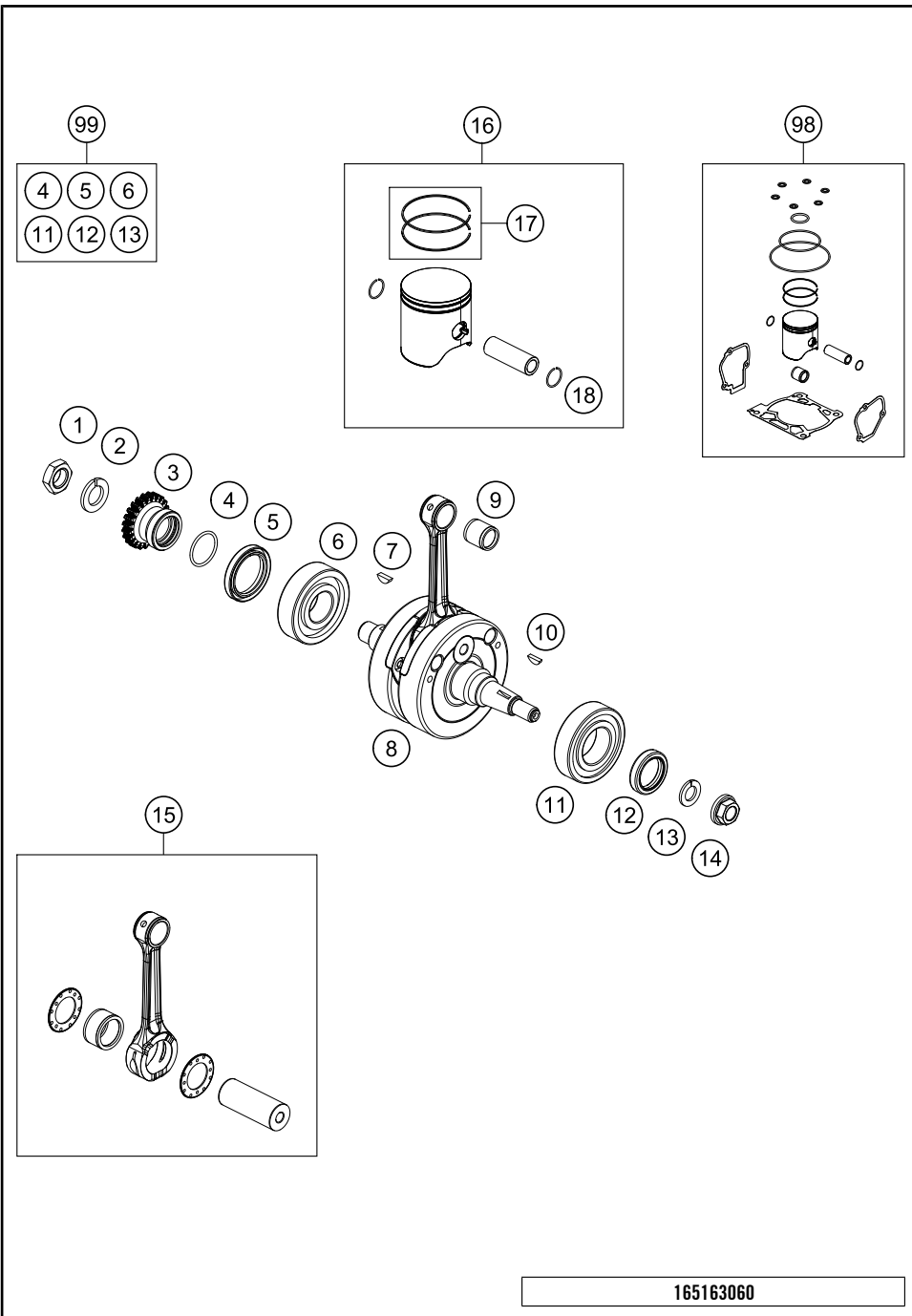

POS	PARTNUMBER	PARTNAME	PIECE
1	50330029000	HEXAGON NUT M 16 X 1,5 - L/S	1
2	50230029016	LOCKING RING VSK 16	1
3	50432023023	PRIMARY WHEEL 23T	1
4	0770250020	O-RING 25,00X2,00 NBR 70	1
5	0760324564	SHAFT SEAL RING 32X45X6,5 BT	1
6	0625063055	BALL BEARING 6305 JR2 CS36	1
7	0888040050	WOODRUFF KEY DIN6888 4X5X13	1
8	50430018000	CRANKSHAFT	1
9	51030034000	NEEDLE BEARING KBK 15X19X20	1
10	0888030050	WOODRUFF KEY DIN6888-3X5X13	1
11	50330082000	CYL.ROLLER BEAR.NJ206 ET2XCS46	1
12	0760253570	SHAFT SEAL RING 25X35X7 BTSL	1
13	50230029012	LOCKING RING VSK 12	1
14	49030021000	COLLAR NUT M12X1 R/S	1
15	50430015044	CON-ROD REPAIR KIT	1
16	51630007000 I	PISTON I CPL. 150	x
16	51630007000 II	PISTON II CPL. 150	x
17	51630032044	PISTON RING SET 150	2
18	50330074500	WIRE LOCK RING 15X1	2
98	00050000235	PISTON KIT SIZE I 150 SX	x
98	00050000236	PISTON KIT SIZE II 150 SX	x
99	00050002300	CRANKSHAFT REP. KIT 125-200	x

165163060

C165163060

\* NEW PART X ON DEMAND



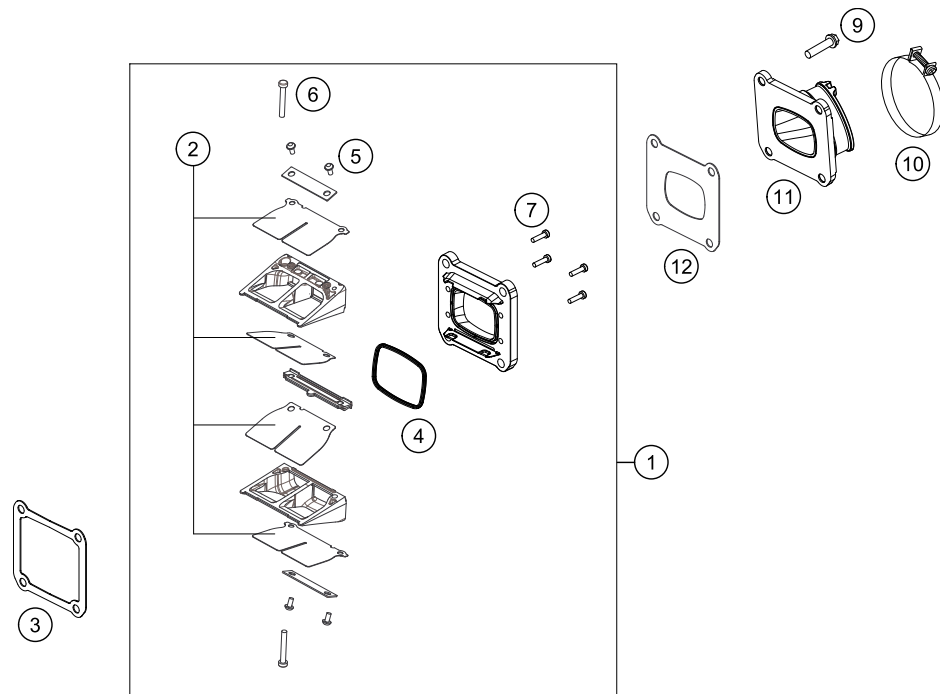

POS	PARTNUMBER	PARTNAME	PIECE
1	50430151044	REED VALVE CASE CPL.	1
2	54830052344	REED VALVE SET	1
3	50430098050	GASKET REED VALVE CASE	1
4	54830153050	GASKET SUPPORTING PLATE	1
5	00810300553	EJOT DELTA PT SCREW 30X5,5	4
6	0081035253	EJOT DELTA PT SCREW 35X25	2
7	0081030124	EJOT DELTA PT SCREW 30X12	4
9	0025060256	HH COLLAR SCREW M6X25 TX30	4
10*	54830061000	CLAMP 54/09 MIXED	1
11*	50430150000	INTAKE FLANGE	1
12	50430098060	GASKET INTAKE FLANGE	1

165043070

C175043070

\* NEW PART

X ON DEMAND

**ACHTUNG !!!**  
 Vor dem Einbau des Vergasers, Bedüsung kontrollieren.

**CAUTION !!!**  
 Before mounting the carburetor, check the jetting.

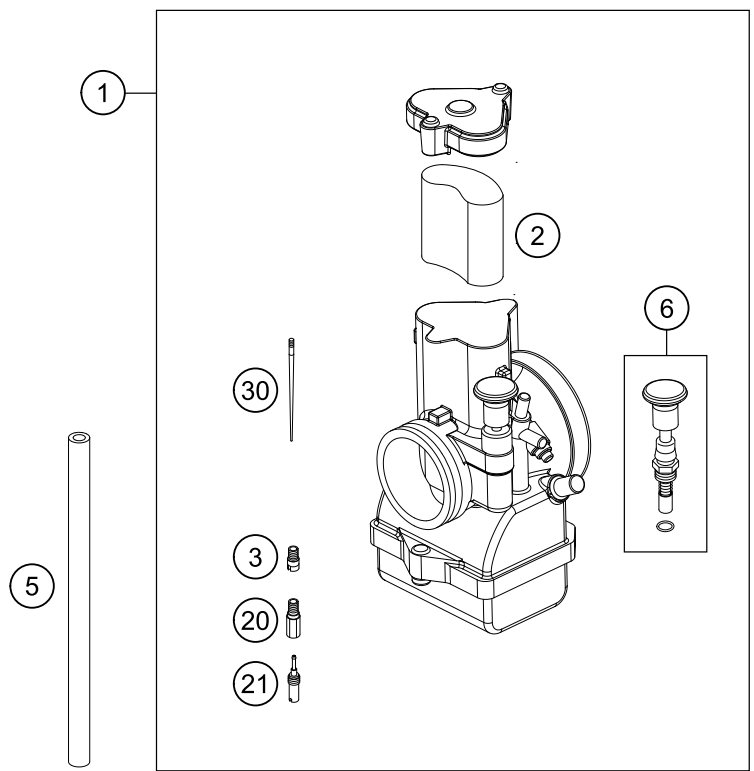

175543110

POS	PARTNUMBER	PARTNAME	PIECE
1	50431101044	CARBURETOR MIKUNI VM38	1
2	55431035040	THROTTLE SLIDE "4.0"	1
3	55431051050	STARTING JET "50"	X
3	55431051080	STARTING JET "80"	X
5	31007007101	PVC-HOSE 4X6MM	X
6	55431245000	START PISTON CPL.	1
20	55431029100	MAIN JET "100"	X
20	55431029155	MAIN JET "155"	X
20	55431029400	MAIN JET "400"	X
20	55431029410	MAIN JET "410"	X
20	55431029420	MAIN JET "420"	X
20	55431029430	MAIN JET "430"	X
20	55431029440	MAIN JET "440"	X
20	55431029450	MAIN JET "450"	X
20	55431029460	MAIN JET "460"	X
20	55431029470	MAIN JET "470"	X
20	55431029480	MAIN JET "480"	X
20	55431029490	MAIN JET "490"	X
20	55431029500	MAIN JET "500"	X
20	55431029520	MAIN JET "520"	X
20	55431029540	MAIN JET "540"	X
20	55431029560	MAIN JET "560"	X
20	55431029580	MAIN JET "580"	X
20	55431029600	MAIN JET "600"	X
21	55431007150	IDLING JET "15"	X
21	55431007175	IDLING JET "17.5"	X
21	55431007300	IDLING JET "30"	X
21	55431007325	IDLING JET "32.5"	X
21	55431007350	IDLING JET "35"	X
21	55431007375	IDLING JET "37.5"	X
21	55431007400	IDLING JET "40"	X
21	55431007425	IDLING JET "42.5"	X
21	55431007450	IDLING JET "45"	X
21	55431007475	IDLING JET "47.5"	X
21	55431007500	IDLING JET "50"	X
21	55431007525	IDLING JET "52.5"	X
30	55431934000	JET NEEDLE "6GAY69-74"	X
30	55431034000	JET NEEDLE "6BFY42-71"	X

C175043110

\* NEW PART X ON DEMAND

**ACHTUNG !!!**  
 Vor dem Einbau des Vergasers, Bedüsung kontrollieren.

**CAUTION !!!**  
 Before mounting the carburetor, check the jetting.

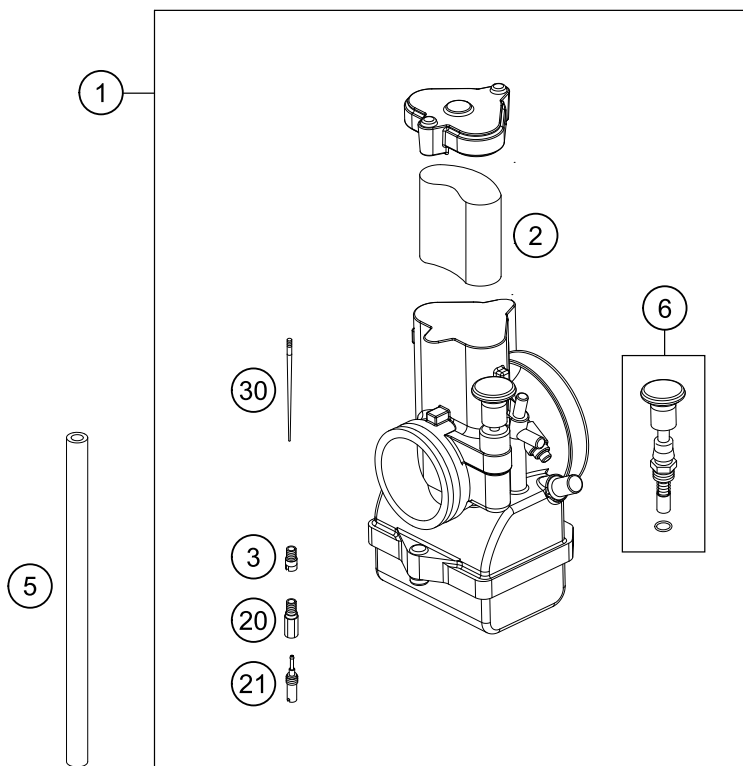

175543110

POS	PARTNUMBER	PARTNAME	PIECE
30	55431034100	JET NEEDLE "6BFY42-72"	X
30	55431034200	JET NEEDLE "6BFY42-73"	X
30	55431034300	JET NEEDLE "6BFY42-74"	X
30	55431034400	JET NEEDLE "6BFY42-75"	X
30	55431034500	JET NEEDLE "6BFY42-76"	X
30	55431134000	JET NEEDLE "6BFY43-71"	X
30	55431134100	JET NEEDLE "6BFY43-72"	X
30	55431134200	JET NEEDLE "6BFY43-73"	X
30	55431134300	JET NEEDLE "6BFY43-74"	X
30	55431134400	JET NEEDLE "6BFY43-75"	X
30	55431134500	JET NEEDLE "6BFY43-76"	X
30	55431234000	JET NEEDLE "6BFY44-71"	X
30	55431234100	JET NEEDLE "6BFY44-72"	X
30	55431234200	JET NEEDLE "6BFY44-73"	X
30	55431234300	JET NEEDLE "6BFY44-74"	X
30	55431234400	JET NEEDLE "6BFY44-75"	X
30	55431234500	JET NEEDLE "6BFY44-76"	X

C175043110

\* NEW PART

X ON DEMAND

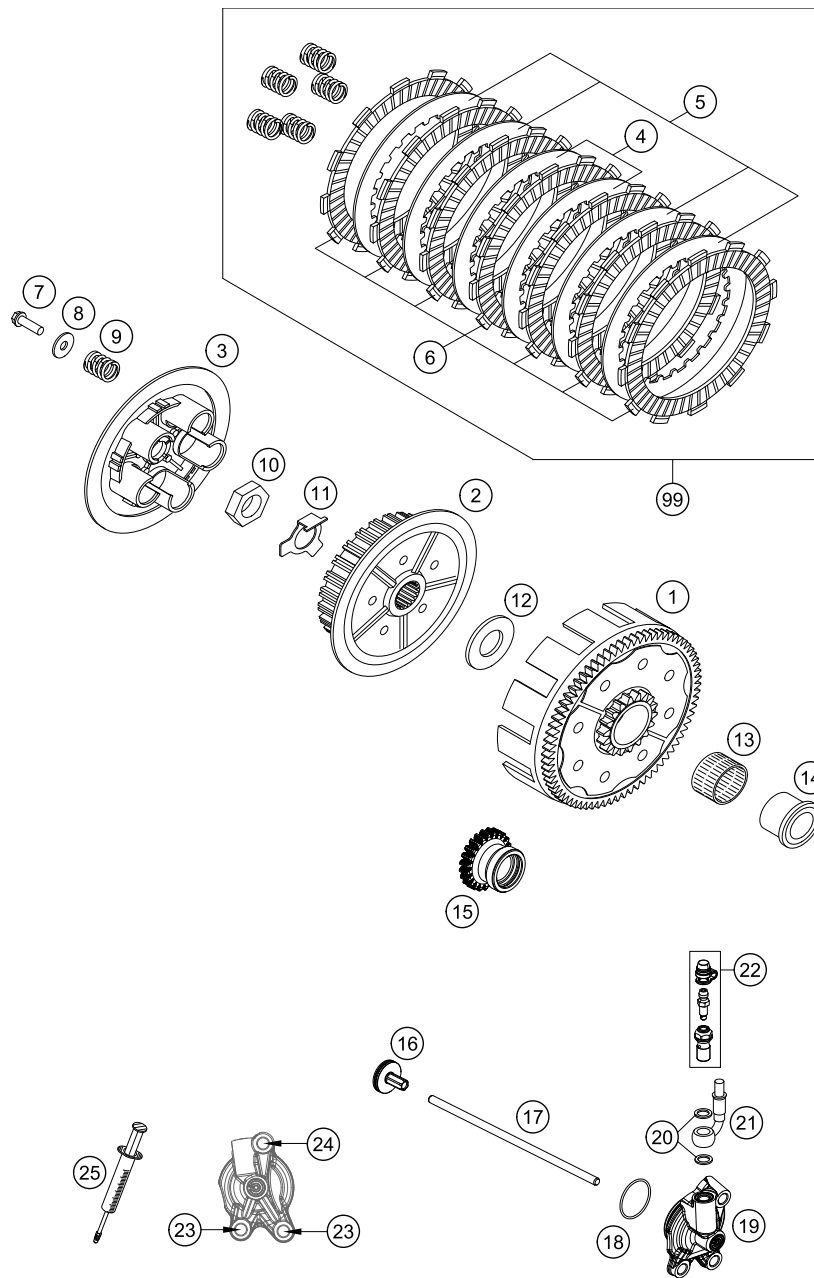

165043210

POS	PARTNUMBER	PARTNAME	PIECE
1	50332001044	OUTER CLUTCH HUB '98	1
2	50332002000	INNER CLUTCH HUB 125/200'98	1
3	50332003000	PRESSURE PLATE 125/200'98	1
4	50332010100	INTERMEDI. DISC STEEL 1,5MM'98	2
5	50332010400	INTERMEDIATE DISC 1,5MM	4
6	77032011000	LINING DISC 3,0MM 05	7
7	0025060206	HH COLLAR SCREW M6X20 TX30	5
8*	50232050000	WASHER 6,2X18X2	5
9*	77032005000	% CLUTCH SPRING	5
10	0936181505	HEXAGON NUT DIN0936-M18X1,5 R.	1
11	50332018000	SHEET METAL LOCK 1,5MM '98	1
12	50332020000	STOP DISK 20X39,6X3 '98	1
13	56532095000	NEEDLE BEARING K26X30X22ZW.KSE	1
14	50332013000	INNER RING 20X26X25,9 '98	1
15	50432023023	PRIMARY WHEEL 23T	1
16	78032057044	PRESSURE PIECE CPL. 08	1
17	50432054000	PUSH ROD	1
18	0770300015	O-RING 30,00X1,50 NBR 70	1
19	79232061044	OUTPUT CYLINDER CPL.	1
20	0603080161	COPPERT GASKET 8x16x1	2
21	79232063000	CLUTCH PIPE	1
22	79032064000	BLEEDER SCREW CPL.	1
23	0025060166	HH COLLAR SCREW M6X16 TX30	2
24	0025060256	HH COLLAR SCREW M6X25 TX30	1
25	50329050000	VENT INJEKTION HYDR. CLUTCH	1
99	50432011010	CLUTCH KIT 125SX 17	1

C175043210

\* NEW PART

X ON DEMAND

**ACHTUNG !!!**  
 Bei Bestellung von Getrieberädern, Markierung beachten.  
**CAUTION !!!**  
 When ordering transmission gears, check marking.

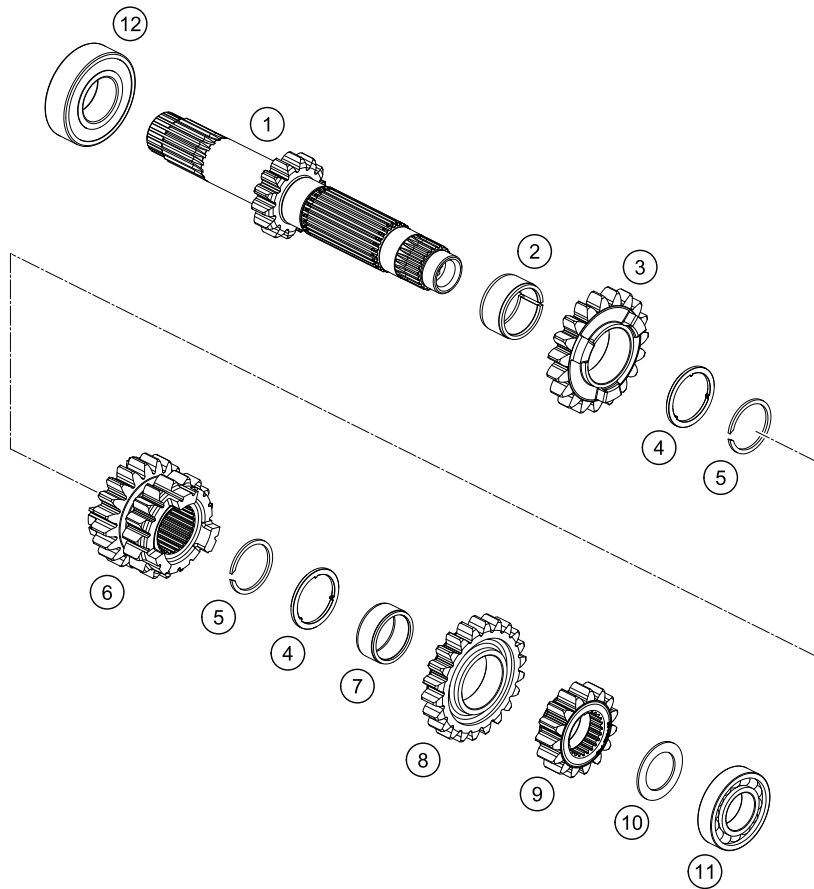
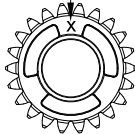

165043330

POS	PARTNUMBER	PARTNAME	PIECE
1	50433001000	DRIVE SHAFT CPL. 14T	1
2	0405212513	NEEDLE BEARING K21X25X13 SPLIT	1
3	50433005000	% IDLER GEAR 5TH GEAR, 19T	1
4	50433043000	STOP DISK	2
5	50133090000	LOCK RING 22X1,2	2
6	50433003000	SLIDING GEAR, 3RD/4TH GEAR	1
7	0405202410	NEEDLE BEARING K20X24X10	1
8	50433006000	IDLER GEAR 6TH GEAR, 22T	1
9	50433002000	SOLID GEAR, 2ND GEAR, 15T	1
10	50333041000	STOP DISC 17,2X26X1 B	1
11	0625160031	GROOVED BALL B. 16003 C4 J1	1
12	0625060041	BALL BEARING 6004 TNH C3	1

C165043330

\* NEW PART

X ON DEMAND

**ACHTUNG !!!**  
 Bei Bestellung von Getrieberädern, Markierung beachten.  
**CAUTION !!!**  
 When ordering transmission gears, check marking.

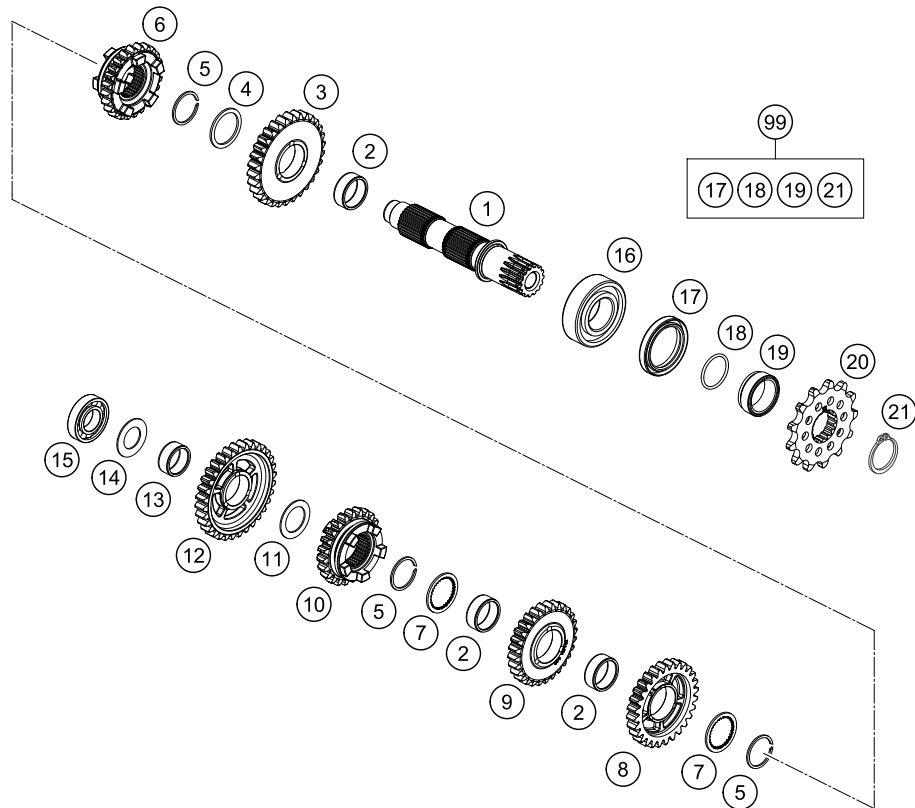
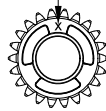

165043360

POS	PARTNUMBER	PARTNAME	PIECE
1	50433010000	DRIVEN SHAFT CPL.	1
2	0405222611	NEEDLE BEAR.K 22X26X10 DIVIDED	3
3	50433012000	IDLER GEAR, 2ND GEAR, 30T	1
4	54833044000	STOP DISC 25X31X1,5	1
5	0417024000	CIRCLIP WS24	3
6	50433016000	SLIDING GEAR, 6TH GEAR, 24T	1
7	54833043000	STOP DISC 25X0,8X30X30X7H	2
8	50433013000	IDLER GEAR, 3RD GEAR, 28T	1
9	50433014000	IDLER GEAR, 4TH GEAR, 28T	1
10	50433015000	% SLIDING GEAR, 5TH GEAR, 23T	1
11	54833080000	STOP DISC 20,2X30X1	1
12	50433011000	IDLER GEAR, 1ST GEAR, 32T	1
13	0405202410	NEEDLE BEARING K20X24X10	1
14	56033030000	STOP DISC 17,2X30X1	1
15	0625160031	GROOVED BALL B. 16003 C4 J1	1
16	0625062054	BALL BEARING 6205 C3 NTN	1
17	0760324571	SHAFT SEAL RING 32X45X7 BSLNBR	1
18	0770230020	O-RING 23,00X2,00 NBR70	1
19	50433030000	SPACER BUSHING 12,4 MM	1
20	79233029013	SPROCKET 13T	1
21	0471250200	CIRCLIP DIN0471 - 25X2	1
99	00050000949	COUNTER SHAFT REP. KIT 125 SX	x

C165043360

\* NEW PART

X ON DEMAND

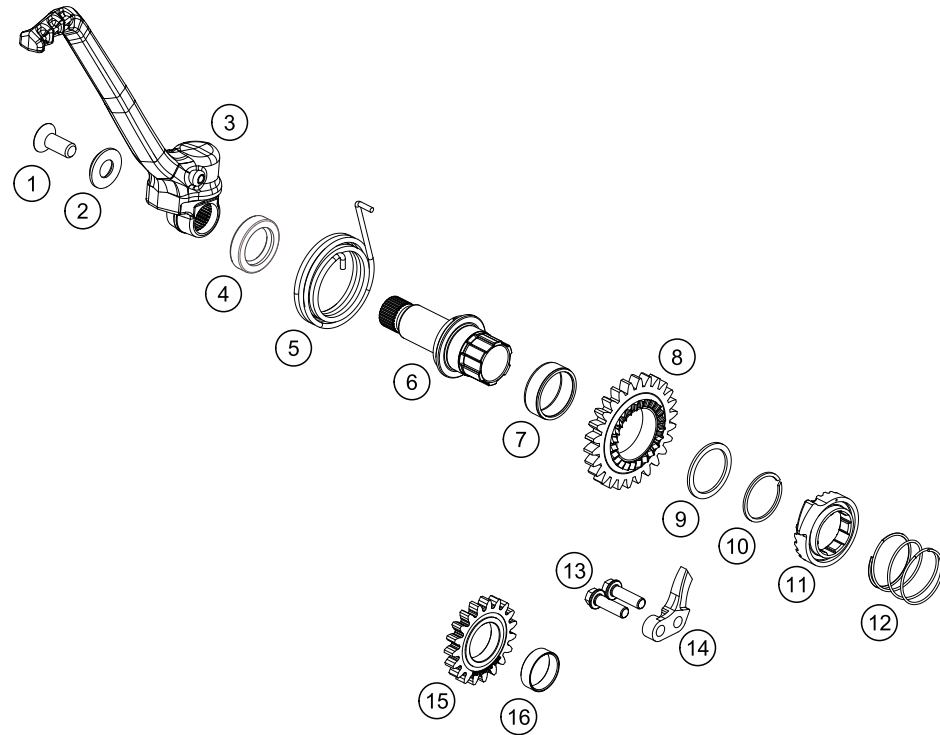

POS	PARTNUMBER	PARTNAME	PIECE
1	0019080206S	FLAT HEAD SCREW M. ISA45 M8X20	1
2	54633037000	WASHER 8MM GALVANIZED	1
3	50433070044	KICKSTARTER CPL.	1
4	0760193070	SHAFT SEAL RING 19X30X7 B	1
5	50433054000	KICK STARTER SPRING	1
6	79233050000	KICK STARTER SHAFT	1
7	0405252910	NEEDLE BEAR K 25X29X10	1
8	50433051026	KICK STARTER WHEEL 26T	1
9	54833044000	STOP DISC 25X31X1,5	1
10	0417025000	CIRCLIP SW25	1
11	50433052000	KICK STARTER RATCHET	1
12	58033028000	RATCHET GEAR SPRING 1,2 MM	1
13	0025060206	HH COLLAR SCREW M6X20 TX30	2
14	59033069000	BUMP PART	1
15	50433053019	STARTER INTERMEDIATE GEAR 19T	1
16	50433024050	BUSHING IDLER GEAR	1

165043390

C165043390

\* NEW PART

X ON DEMAND

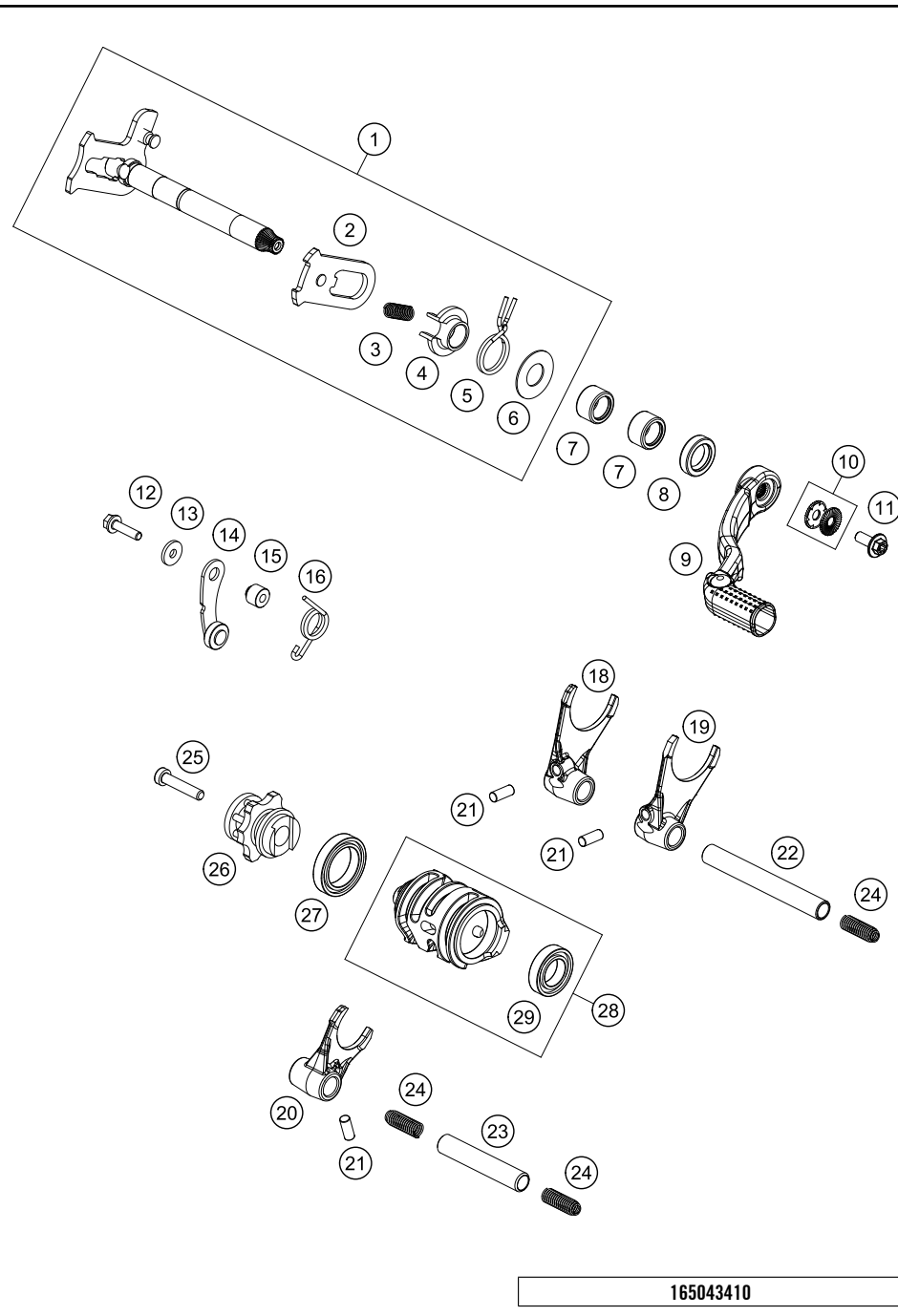

POS	PARTNUMBER	PARTNAME	PIECE
1	54834005133	SHIFT SHAFT ASSY	1
2	61234008044	SLIDING PLATE	1
3	56534013100	TENSIONING SPRING 0,8MM	1
4	54634020000	SPRING GUIDE	1
5	54834014000	RETURN SPRING 03	1
6	54634050000	STOP DISK 14X30X1	1
7	54632095000	NEEDLE BEAR.HK 1412 14X20X12	2
8	0760142460	SHAFT SEAL RING 14X24X6 B	1
9*	50434031000	SHIFT LEVER CPL.	1
10	50233041500	PAIR NORDLOCK WASHER M6	1
11	0024060156S	HH COLLAR SCREW M6X15 TORX30	1
12	0025050206	HH COLLAR SCREW M5X20 TX30	1
13	0349000050	WASHER DIN7349-5X15X2	1
14	50334024144	LOCATING LEVER CPL. 08	1
15	54634052300	SLEEVE FOR LOCKING LEVER	1
16	54834023000	LOCKING LEVER SPRING 03	1
18	50434003000	SHIFTING FORK 1ST/3RD GEAR	1
19	50434002000	SHIFTING FORK 2ND/4TH GEAR	1
20	50434001000	SHIFTING FORK 5/6 GEAR	1
21	0402061480	NEEDLE ROLLER DIN5402 6X14,8	3
22	54834020000	SHIFT. RAIL C. SHAFT 250/300	1
23	54834019000	SHIFT. RAIL MAIN SHAFT 250/300	1
24	58038023200	PRESSURE SPRING 0,9MM	3
25	0012060303	% AH SCREW DIN6912 M6X30 8.8	1
26	50434015033	SHIFT DRUM LOCATING CPL.	1
27	0625618050	BALL BEARING 61805 C3	1
28	50434012033	SHIFTING DRUM CPL.	1
29	0625069034	BALL BEARING 6903 C4	1

165043410

C175043410

\* NEW PART X ON DEMAND



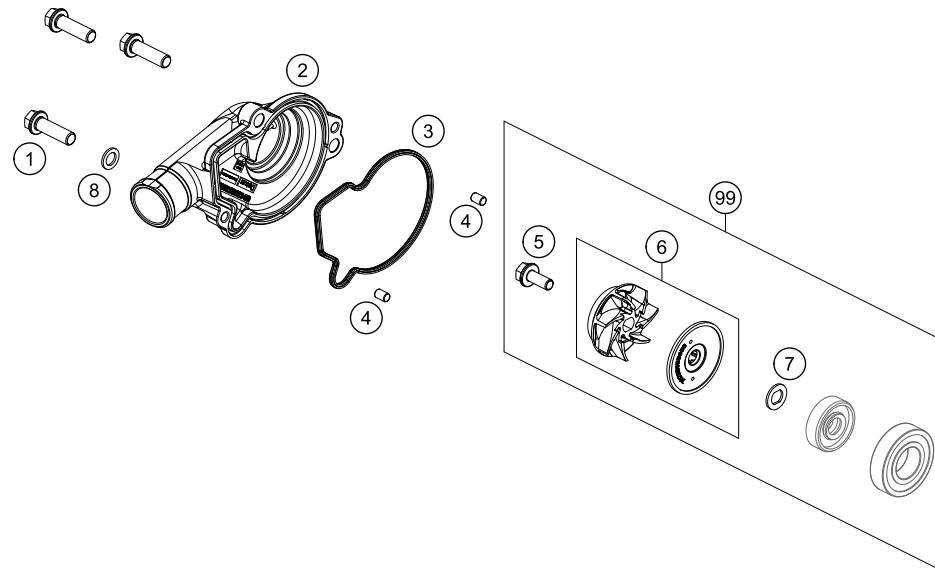

POS	PARTNUMBER	PARTNAME	PIECE
1	0025060206	HH COLLAR SCREW M6X20 TX30	3
2	50435052000	WATER PUMP COVER	1
3	50435053000	GASKET WATER PUMP COVER	1
4	0402040600	NEEDLE ROOLER DIN5402 NRB 4X6	2
5	0014050123	HH COLLAR SCREW M 5X12 WS=6	1
6	79235055044	WATER PUMP WHEEL CPL.	1
7	50435049000	PREFORMED WASHER	1
8	0603061001	CU-SEAL RING DIN7603-6X10X1	1
99	50435055015	WATER PUMP REP. KIT	X

165043510

C165043510

\* NEW PART

X ON DEMAND

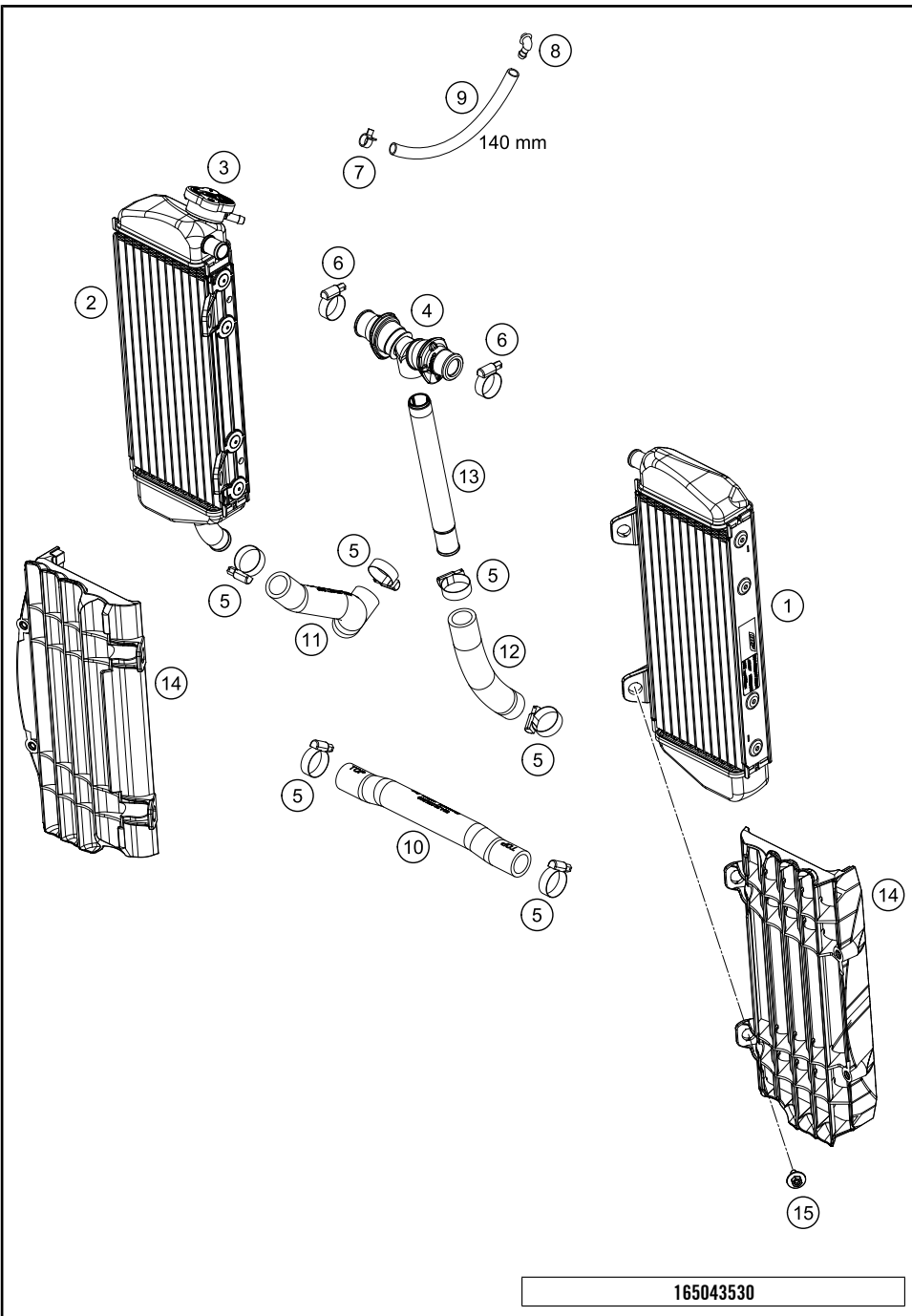

POS	PARTNUMBER	PARTNAME	PIECE
1*	50435007100	RADIATOR LEFT 17	1
2*	50435008100	RADIATOR RIGHT 17	1
3	79035016000	RADIATOR CAP 1,8 BAR	1
4	79035071044	Y-PIECE CPL.	1
5	10001020000	HOSE CLAMP GEMI 18-29	6
6	42013037400	HOSE CLAMP NORMA 14/24	2
7	59007017000	CLAMP YDNAC 10096F (9,6MM)	1
8	50303089000	ANGLE PIECE '97	1
9	50335030001	PVC-HOSE 6X9	x
10	50435025000	PREFORMED HOSE RADIATOR	1
11	50435027000	PREFORM.HOSE ENGINE/RAD. R/S	1
12	50335025142	RADIATOR HOSE 18x25x142 07	1
13*	50435073000	COOLING WATER PIPE	1
14	7903503400030	RADIATOR PROTECT 2016	2
15	0024060123	COLLAR SCREW M6X12 TX	4

165043530

C175043530

\* NEW PART X ON DEMAND

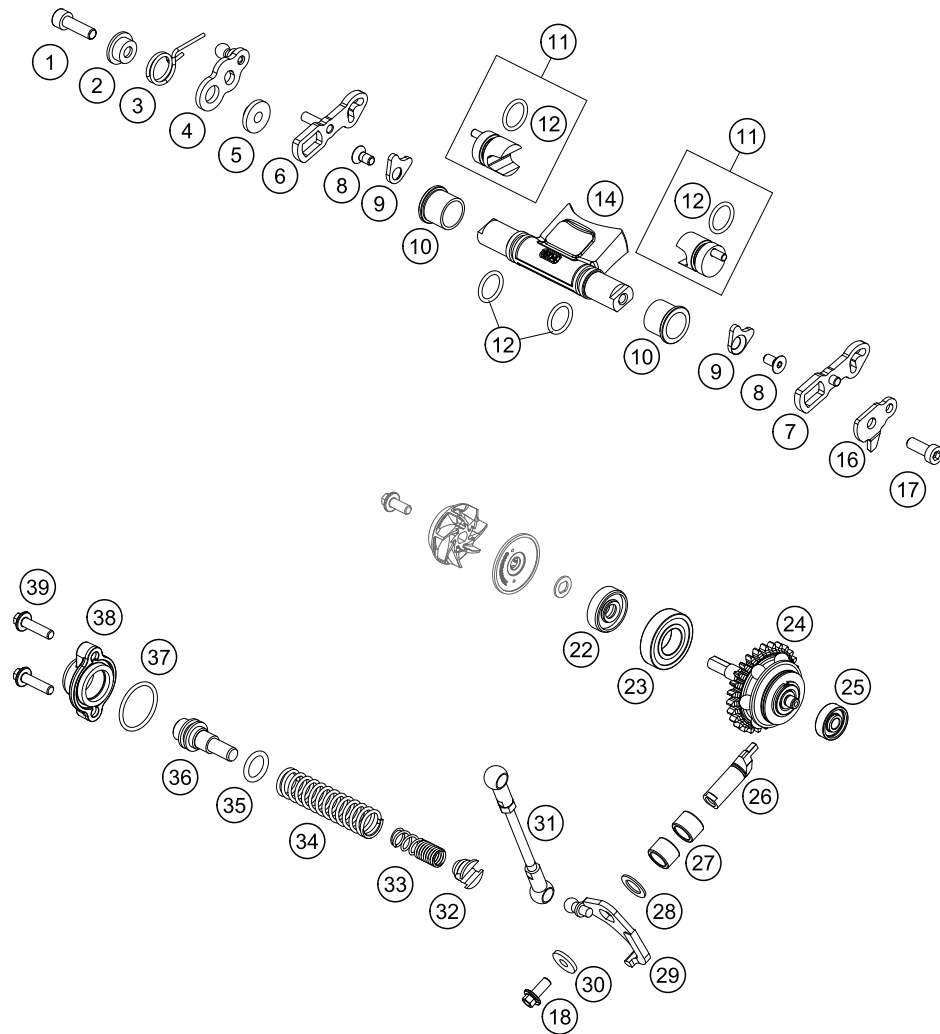

165043710

POS	PARTNUMBER	PARTNAME	PIECE
1	0912060203	AH SCREW DIN0912-M 6X20	1
2	54637067000	SPRING SLEEVE	1
3	54637066000	OVERLOAD SPRING	1
4	54637065000	CONTROL LEVER WITH BALL TYPE	1
5	54637068100	BUSHING SLEEVE	1
6	50437065044	SLOTTED LEVER R/S	1
7	50437064044	SLOTTED LEVER L/S	1
8	0019050106S	INT. TORX FLAT HEAD M5X10 10.9	2
9	50437079000	LOCK PLATE	2
10	50437023000	BEARING SLEEVE F. CONTROL FLAP	2
11	51637061044	CONTROLLER DRUM CPL.	2
12	0770140201	O-RING 14X2 FPM 75SH	4
14	51637020000	EXHAUST FLAP	1
16	50437085000	STOP PLATE	1
17	0912060163	AH SCREW DIN0912-M 6X16	1
18	0014050123	HH COLLAR SCREW M 5X12 WS=6	1
22	0760082472	SHAFT SEAL RING 8X24X7 A DUO	1
23	0625160020	BALL BEARING 16002 C3	1
24	50437050044	CENTRIFUGAL UNIT	1
25	54637098100	BALL BEARING 626LLBC3/5K	1
26	50437057100	ADJUSTING LEVER 125/150 2016	1
27	0618101410	NEEDLE SLEEVE HK 1010 10/14/10	2
28	0988101610	SHIM WASHER DIN988 10X16X1	1
29	54637055244	ANGLE LEVER CPL. '91	1
30	0349000050	WASHER DIN7349-5X15X2	1
31	50437095044	CONNECTING ROD CPL.	1
32	54637071200	SPRING INSERT	1
33	50437069050	SUPPORT SPRING	1
34	54637072000	ADJUST.SPRING L=65MM D=1,8MM	1
35	0770021120	O-RING 12,37X2,62 NBR70	1
36	54837075000	SPRING GUIDE 250/300	1
37	0770240020	O-RING 24,00X2,00 NBR70	1
38	54637070100	COVER LID 250-380'98	1
39	0014050203	HH COLLAR SCREW M 5X20 WS=6	2

C165163710

\* NEW PART

X ON DEMAND

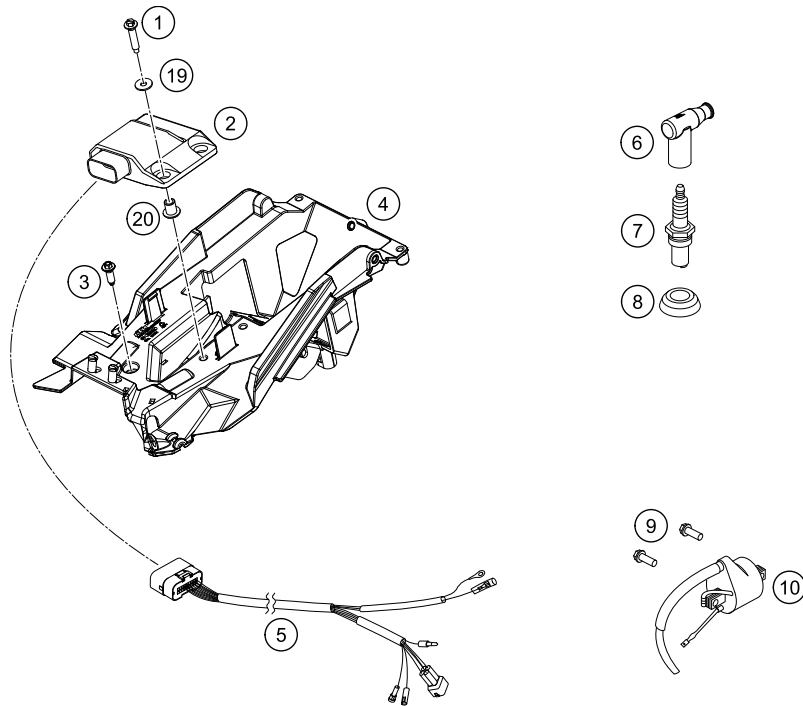

POS	PARTNUMBER	PARTNAME	PIECE
1	0017060305	SPECIAL SCREW K60X30 WS=6	2
2*	51639131000	ELEKTRONIC BOX 150XC-W 17	1
3	0017060206	SCREW F. PLASTIC K60X20AL SW6	1
4	79011055000	BATTERY BOX	1
5	54839032200	WIRING HARNESS FOR CDI 2-ST.07	1
6	47039090000	SPARK PLUG CAP NGK REINFORC.04	1
7	51539093000	SPARK PLUG BR9ECMVX	1
8	50439091000	SEALING SLEEVE	1
9	0026060186	COLLAR SCREW M6X18 ISA30	2
10	59039006000	IGNITIONCOIL "IG5128"	1
11	50439013000	DISTANCE UNIT	1
12	50439004000	STATOR	1
13	50439004010	PICKUP BRACKET	1
14	0014050163	HH COLLAR SCREW M 5X16 WS=6	2
15	0912050253	AH SCREW DIN0912-M 5X25	2
16	50439005000	ROTOR	1
17	50430002000	IGNITION COVER SX	1
18	0025060206	HH COLLAR SCREW M6X20 TX30	6
19	0021050003	WASHER DIN9021-A 5,3	2
20	60308006000	COLLAR BUSHING 6,2X9,2X15X12,5	2

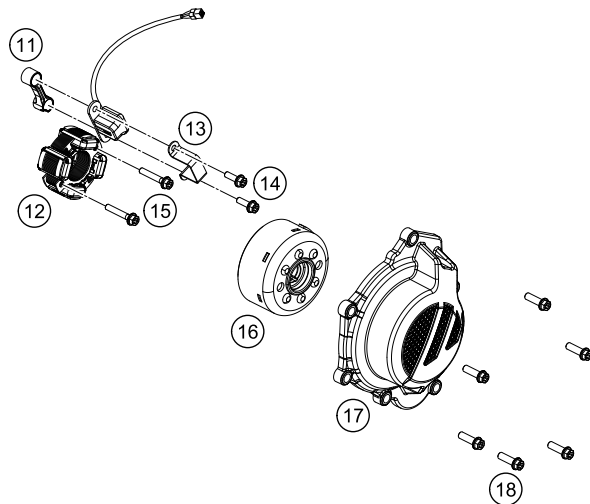

165043910

C175163910

\* NEW PART

X ON DEMAND

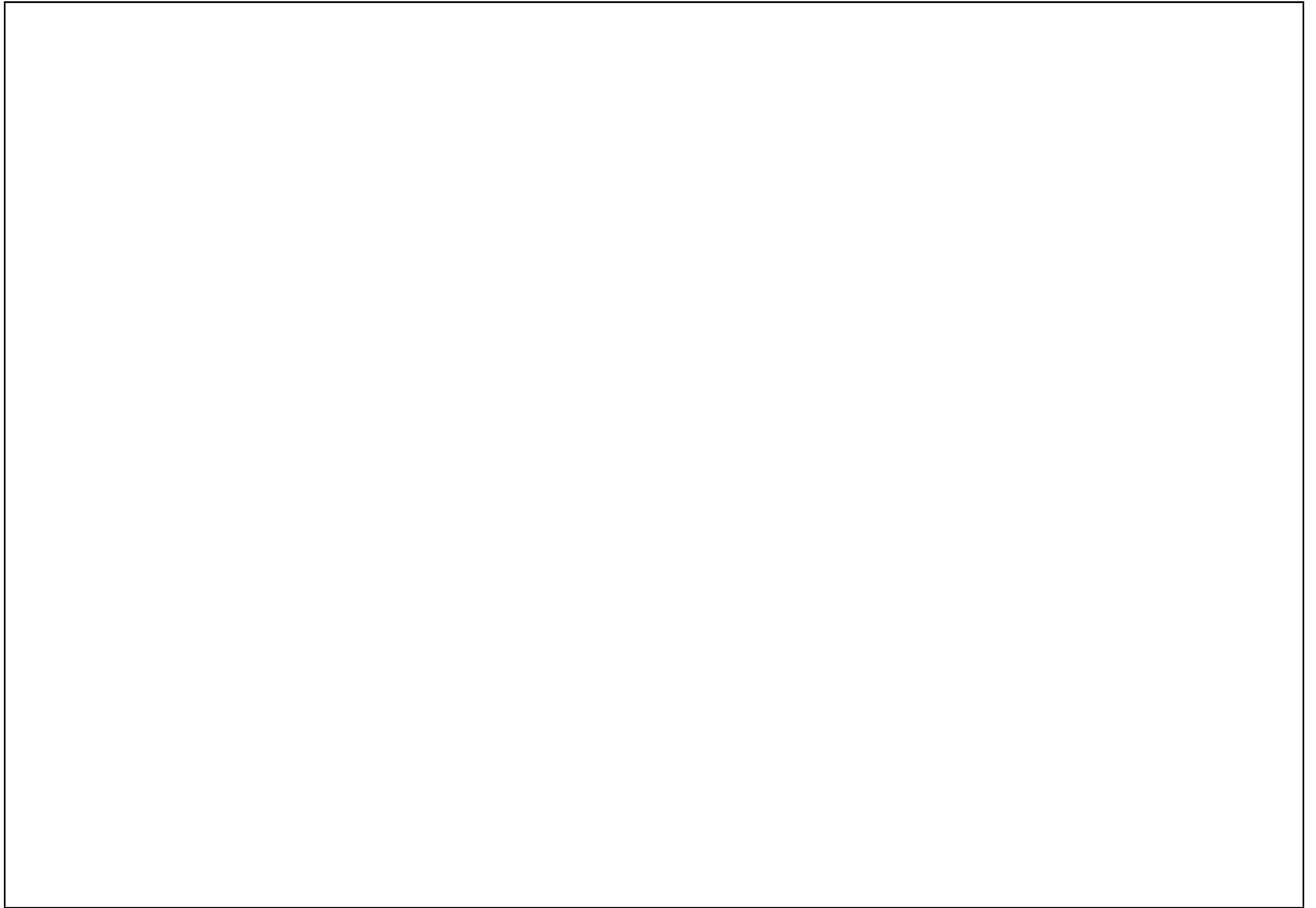

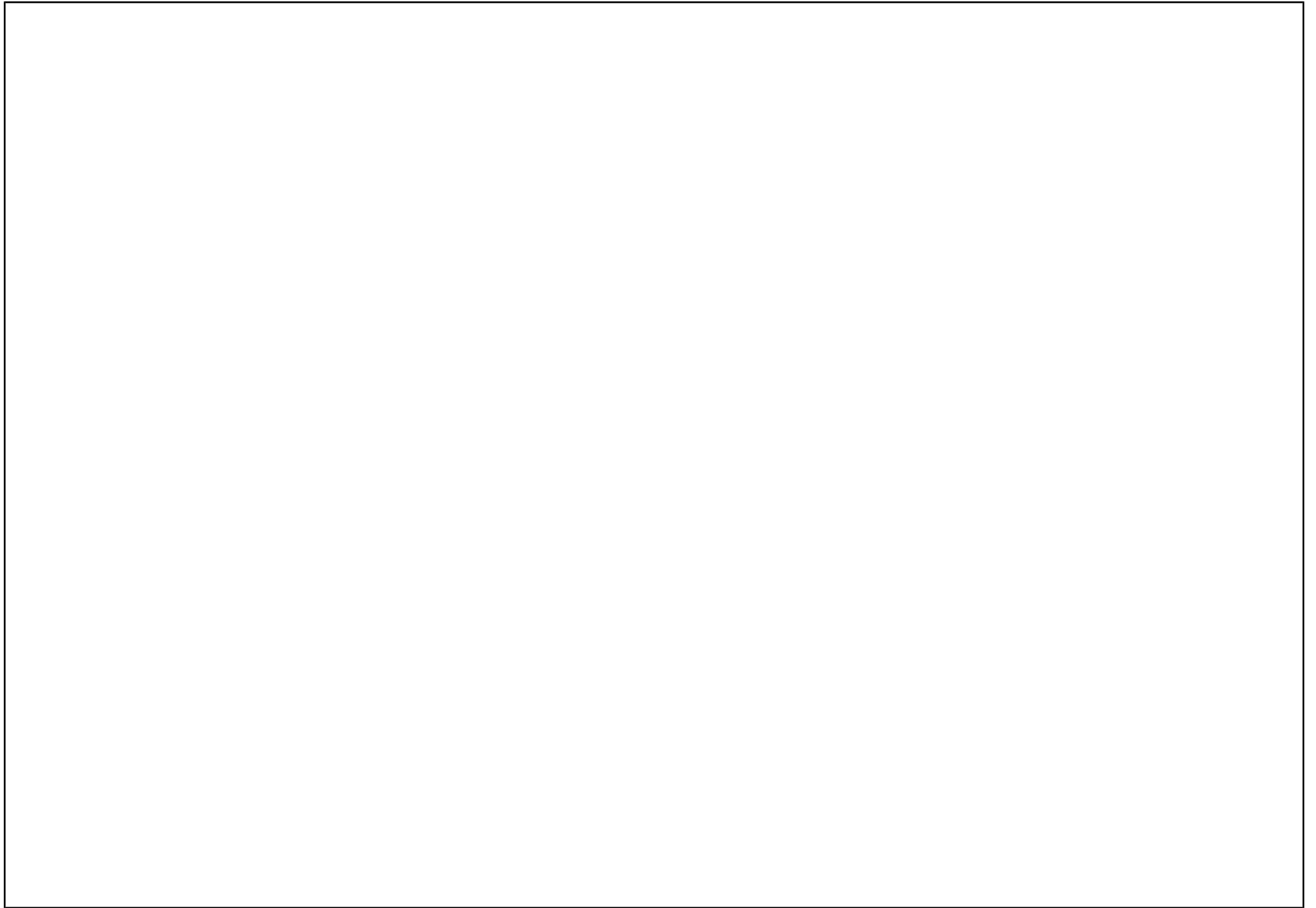



WWW.KTM.COM



KTM Sportmotorcycle GmbH  
5230 Mattighofen, Austria  
www.ktm.com



**KTM**\_POWERPARTS

**KTM**\_POWERWEAR

**KTM**\_ORIGINAL SPARE PARTS



3CM081530QEN

Art. Nr.: 3CM081530QEN 7. Apr 2016