

125 EXE, SUPERMOTO

KTM
SPORTMOTORCYCLES

BEDIENUNGSANLEITUNG

OWNERS HANDBOOK

MANUAL DE INSTRUCCIONES

2001



Art.Nr. 3.205.96 3/2001

IMPORTANT

WE STRONGLY SUGGEST THAT YOU READ THIS MANUAL CAREFULLY AND COMPLETELY BEFORE GOING ON YOUR FIRST RIDE. IT CONTAINS A GREAT DEAL OF INFORMATION AND ADVICE WHICH WILL HELP YOU USE AND HANDLE YOUR BIKE PROPERLY. IN YOUR OWN INTEREST, PLEASE PAY PARTICULAR ATTENTION TO NOTICES THAT ARE MARKED AS FOLLOWS:

⚠ **WARNING** ⚠

IGNORING THESE INSTRUCTIONS, CAN ENDANGER YOUR BODY AND YOUR LIFE.

! **CAUTION** !

IGNORING THESE INSTRUCTIONS COULD CAUSE DAMAGE TO PARTS OF YOUR MOTORCYCLE OR THAT THE MOTOR-CYCLE IS NOT ROAD-SAFE ANYMORE.

Please insert the series numbers of your motorcycle in the boxes below

Chassis number

Engine number

Stamp of dealer

KTM SPORTMOTORCYCLE AG RESERVES THE RIGHT TO MODIFY ANY EQUIPMENT, TECHNICAL SPECIFICATIONS, COLORS, MATERIALS, SERVICES OFFERED AND RENDERED, AND THE LIKE SO AS TO ADAPT THEM TO LOCAL CONDITIONS WITHOUT PREVIOUS ANNOUNCEMENT AND WITHOUT GIVING REASONS, OR TO CANCEL ANY OF THE ABOVE ITEMS WITHOUT SUBSTITUTING THEM WITH OTHERS. IT SHALL BE ACCEPTABLE TO STOP MANUFACTURING A CERTAIN MODEL WITHOUT PREVIOUS ANNOUNCEMENT. IN THE EVENT OF SUCH MODIFICATIONS, PLEASE ASK YOUR LOCAL KTM DEALER FOR INFORMATION. WE SHALL NOT BE HELD LIABLE FOR ANY PRINTING ERRORS.

Introduction

We would like to congratulate you on your purchase of a KTM motorcycle.

You are now the owner of a state-of-the-art sports motorcycle that guarantees to bring you lots of fun and enjoyment, provided that you clean and maintain it appropriately. **Before you go for your first ride, be sure to read this manual carefully and thoroughly in order to familiarize yourself with how to operate your new motorcycle and with its characteristics, even if this means that you have to dedicate some of your valuable time to this task. Only by doing so will you learn how to tune your motorbike to your specific needs and how to protect yourself against injury. Besides, this manual contains important information on motorcycle maintenance.** At the time this manual was typeset, it was up-to-date with the latest state of this production series. It cannot be completely ruled out, however, that there may exist minor discrepancies resulting from further design upgrades of these motorcycles.

This manual is an important part of your motorbike and should be passed on to any subsequent owner in case you decide to sell it.

Many motorcyclists have a good working knowledge of motorcycle mechanics; if this is true in your case, you will be able to use this manual to carry out most of the maintenance steps yourself. If, on the other hand, you are not very familiar with motorcycles, it might be better to have a professional KTM dealer perform those steps marked * described in the chapter entitled "Maintenance Work on Chassis and Engine" of this manual.

For your own safety use only KTM-approved parts and accessories. KTM is not liable for damage that arises in connection with the use of other products.

Take special care to follow the recommended run in, inspection, and maintenance intervals. Heeding these guidelines will significantly increase the life of your motorcycle. Have services carried out by a KTM dealer so that your warranty claim remains intact.

We wish you a lot of fun when driving !



KTM Austria's certificate of achievement for its Quality System ISO 9001 is the beginning of an on-going total re-engineering quality plan for a brighter tomorrow.

KTM SPORTMOTORCYCLE AG
5230 MATTIGHOFEN, AUSTRIA

ALL RIGHTS RESERVED TO MAKE ALTERATIONS TO DESIGN AND MODEL.

INDEX

	Page		Page
SERIAL NUMBER LOCATIONS	.4	Chain maintenance	.18
Chassis number	.4	Chain wear	.18
Engine number, engine type	.4	General informations about KTM disc brakes	.18
OPERATION INSTRUMENTS	.4	Adjusting of free travel at the hand brake lever	.19
Clutch lever	.4	Checking of brake fluid level - front brake	.19
Hand brake lever	.4	Refilling the front brake fluid reservoir	.19
Speedometer, indicator lamps	.5	Checking the front brake pads	.19
Ignition lock	.5	Changing the basic position of the brake pedal	.20
Combination switch	.5	Checking rear brake fluid level	.20
Flasher switch	.5	Refilling the rear brake fluid reservoir	.20
Filler cap	.6	Checking the rear brake pads	.20
Fuel	.6	Dismounting and mounting the front wheel	.21
Fuel tap	.6	Dismounting and mounting the rear wheel	.21
Oil tank	.7	Tires, air pressure	.22
Choke	.7	Checking spoke tension	.22
Shift lever	.7	Main fuse	.23
Kickstarter	.7	Replacing head light lamp (H4)	.23
Foot brake pedal	.7	Charging the battery	.23
Steering lock	.8	Cooling system	.24
Center stand	.8	Checking the coolant level	.24
Baggage carrier	.8	Changing the original position of the clutch lever	.24
Compression damping of fork	.8	Checking the oil level of the hydraulic dorch	.25
Rebound damping of fork	.8	Adjusting the idle speed	.25
Compression damping of shock absorber	.9	Check transmision oil level	.25
Rebound damping of shock absorber	.9	Changing the transmission oil	.25
DRIVING INSTRUCTIONS	.10	Trouble shooting	.26
PERIODIC LUBRICATION- AND MAINTENANCE-SCHEDULE	.13	CLEANING	.28
MAINTENANCE WORK ON CHASSIS AND ENGINE	.14	CONSERVATION FOR WINTER OPERATION	.28
Dismounting and mounting of seat	.14	STORAGE	.28
Checking and adjusting the steering head bearing	.15	Use after period of storage	.28
How to change the handlebar position	.15	TECHNICAL SPECIFICATIONS - CHASSIS	.29
Breather plug front fork	.16	TECHNICAL SPECIFICATIONS - ENGINE	.30
Cleaning the dust sleeves of the telescopic fork	.16	HEAD WORD INDEX	.31
Changing the spring preload of the shock absorber	.16	WIRING DIAGRAMME	.Appendix
Pivot bearing	.17		
Check chain tension	.17		
Correct chain tension	.17		

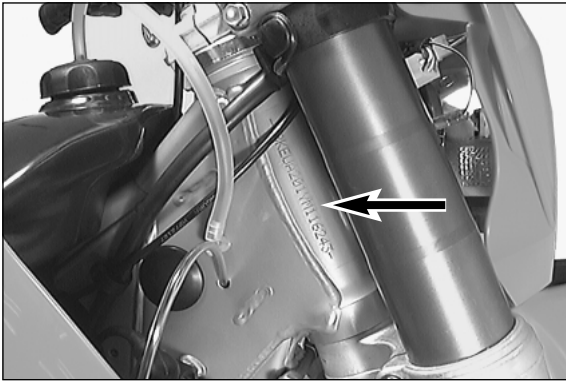

SERIAL NUMBER LOCATIONS

Chassis number

The chassis number is stamped on the right side of the steering head tube. Write this number into the field on page no 1.

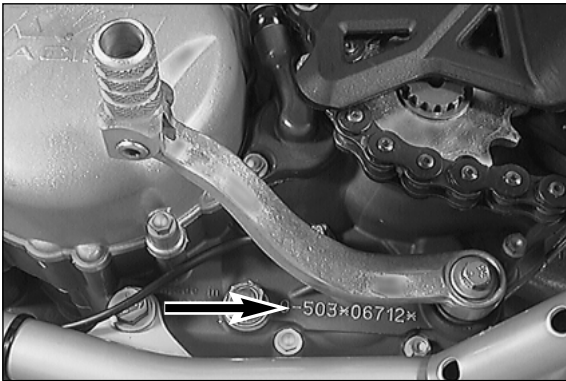

Engine number, engine type

The engine number and the engine type are stamped into the left side of the engine below the engine sprocket. Please note this number down on page 1.

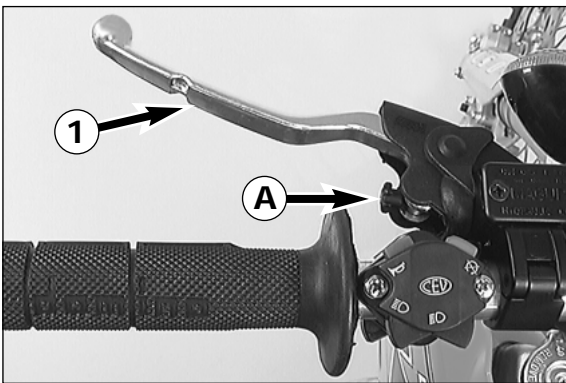

OPERATION INSTRUMENTS

Clutch lever

The clutch lever ① is located on the left side of the handlebar. The adjusting screw ① is used to change the original position of the clutch lever (see maintenance work on chassis and engine).

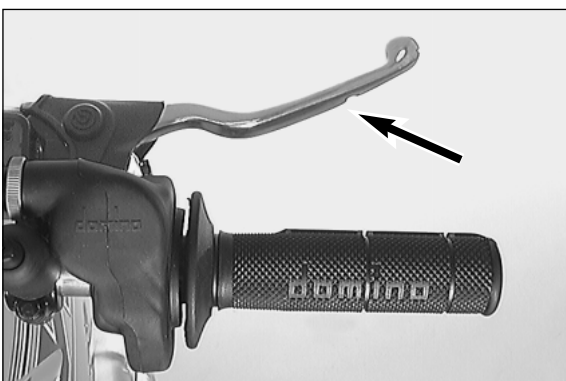

Hand brake lever

The hand brake lever is mounted on the handle bars on the right and actuates the front wheel brake.



WARNING



IF THE RESISTANCE IN THE HAND BRAKE LEVER OR FOOT BRAKE PEDAL FEELS "SPONGY" (TOO MUCH GIVE), THIS IS AN INDICATION THAT SOMETHING IS WRONG WITH THE BRAKE SYSTEM. DON'T RIDE YOUR MOTORCYCLE ANYMORE WITHOUT FIRST HAVING THE BRAKE SYSTEM LOOKED OVER BY A KTM DEALER.

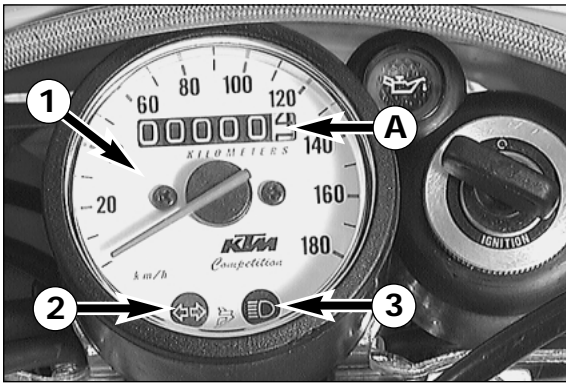

Speedometer, indicator lamps

The mileage indicator **A** in the speedometer **1** indicates overall mileage. When the turn indicator is on, the green indicator lamp **2** will be flashing in the same rhythm. The blue indicator lamp **3** will be lit when the high beam is on

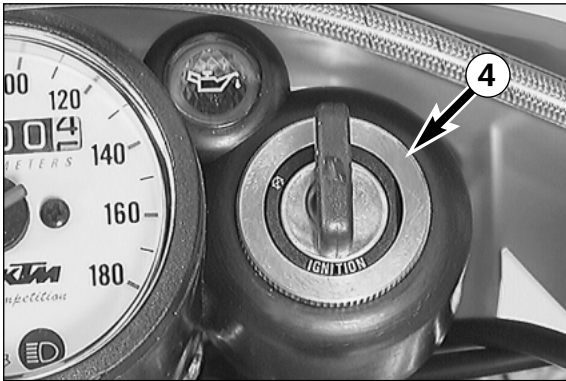

Ignition lock

Switch positions of ignition lock **4**

⊠ = Ignition off

○ = Ignition on, parking light on (only for models with battery)

! CAUTION !

DONT TURN THE PARK LIGHT FOR MORE THAN 90 MINUETS, WHEN THE MOTOR IS NOT RUNNING, BECAUSE THE BATTERY WILL BE COMPLETELY EMPTIED AND DESTROYED.

The ignition key **5** can be removed when in its ⊠ position.

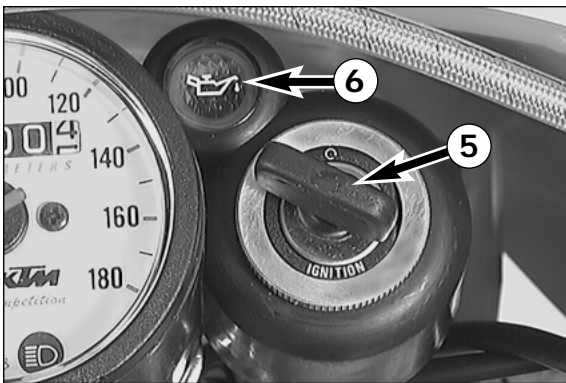

 The red oil level warning lamp **6** lights up when the ignition is switched on, indicating that the oil level warning system works properly.

- If the two-stroke oil level in the oil tank is sufficiently high, the oil level warning lamp will go out after approximately two seconds.
- If the oil level has decreased to approximately 300 ccm, the oil level warning lamp will stay on, reminding you that the oil tank must be refilled with two-stroke oil (e.g. Shell Advance Ultra 2) within the next 100 kilometers.

! CAUTION !

- CHECK FUNCTION OF OIL LEVEL WARNING LAMP BEFORE EVERY RIDE
- ONCE THERE IS NO TWO-STROKE OIL IN THE OIL TANK, THE ENGINE IS BOUND TO BREAK DOWN.

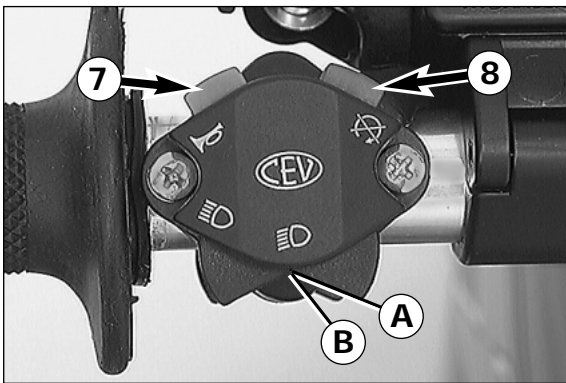

Combination switch

The light switch has 2 switch positions.

A = Low beam on

B = High beam on

You may use button **7** to actuate the horn.

The red short circuit button **8** serves to switch off the engine. Leave the switch pressed until the engine stops.

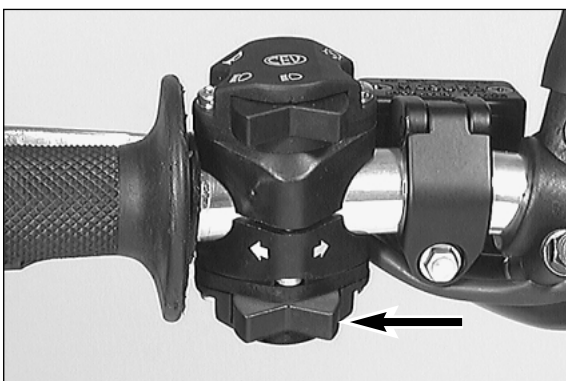

Flasher switch

↶ Flasher left

↷ Flasher right



Filler cap

To open it: turn filler cap counter-clockwise.

To close it: put filler cap back on and tighten it by turning it clockwise. Install tank breather hose ❶ without kinks.

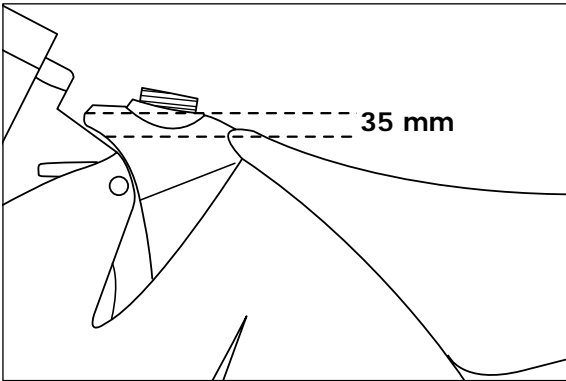

Fuel

This motorcycle is equipped with separate lubrication. This means that the two-stroke oil required for engine lubrication is not admixed to the fuel but contained in a separate oil tank (see below). An oil pump is used for controlled admixing of two-stroke oil into the fuel in the carburetor.

Besides, the motorcycle is equipped with a catalytic converter. Therefore, it is absolutely necessary to fill in unleaded fuel.

Fuel:

UNLEADED REGULAR GASOLINE WITH AT LEAST 91 OCTANES (RON)

Fuel expands when its temperature rises. Therefore do not fill the tank to the top (see fig.).

Fuel tank capacity 11,0 liter



WARNING



GASOLINE IS HIGHLY FLAMMABLE AND POISONOUS. EXTREME CAUTION SHOULD BE USED WHEN HANDLING GASOLINE. DO NOT REFUEL THE MOTORCYCLE NEAR OPEN FLAMES OR BURNING CIGARETTES. ALWAYS SWITCH OFF THE ENGINE BEFORE REFUELLING. BE CAREFUL NOT TO SPILL GASOLINE ON THE ENGINE OR EXHAUST PIPE WHILE THE ENGINE IS HOT. WIPE UP SPILLS PROMPTLY. IF GASOLINE IS SWALLOWED OR SPLASHED IN THE EYES, SEEK A DOCTOR'S ADVICE IMMEDIATELY.



CAUTION



NEVER FILL IN LEADED FUEL. LEADED FUEL WILL DESTROY THE CATALYTIC CONVERTER.

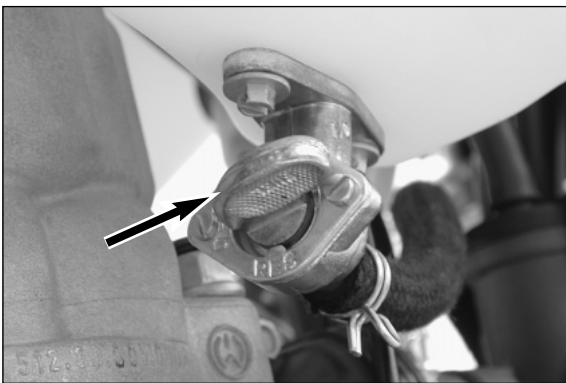

Fuel tap

OFF In this position the fuel tap is closed. No fuel may flow to the carburetor.

ON When using the motorcycle, the twist grip must be set to the ON position. Now fuel may flow to carburetor. In this position the tank empties down to the fuel reserve of approx. 3 liters.

RES The reserve tank, approximately 3 liters, cannot be tapped until the twist grip is turned to the RES position. Fill the tank as soon as possible and remember to turn the twist grip back to the ON position so that you will have backup fuel next time, too.



CAUTION



THE FUEL TAP SHOULD BE LOCKED WHENEVER THE MOTORCYCLE IS PARKED. IF THE TAP IS NOT CLOSED THE CARBURETOR MAY OVERFLOW AND FUEL GET INTO THE ENGINE.

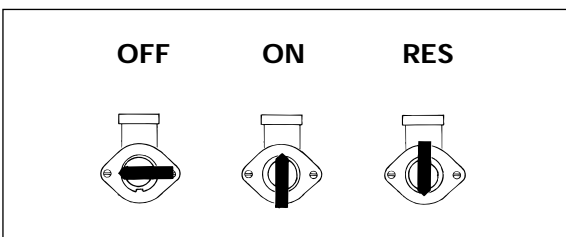

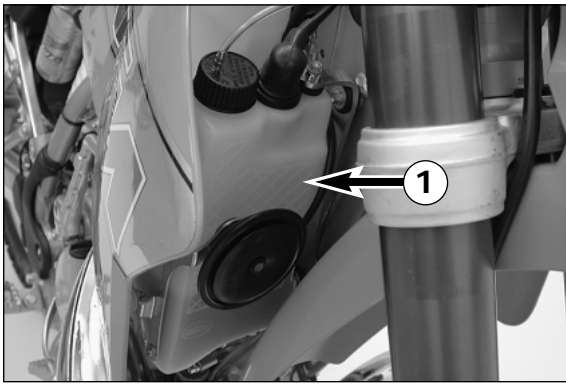

Oil tank

The oil tank ❶ is mounted on the right side in front of the fuel tank. Here, the two-stroke oil for separate lubrication of the engine must be filled in. The oil level can easily be checked through the transparent material of the oil tank.

Engine oil:

2-stroke engine oil suitable for a mixing ratio of 1:50
and for separate lubrication

KTM recommends SHELL ADVANCE Ultra 2

To open it: pull vent hose out of the frame and turn closure cap counter-clockwise.

To close it: apply closure cap and turn it clockwise. Stick vent hose into frame and install it without kinks.

Tank volume: 1.3 liters

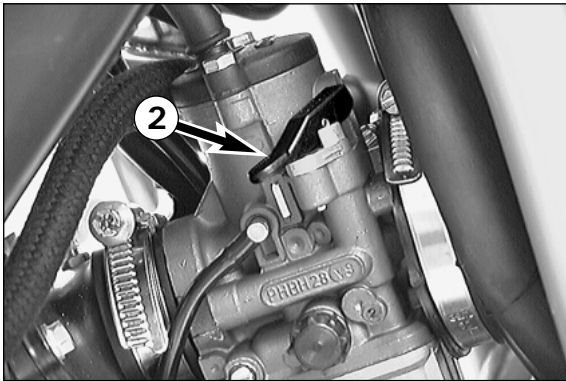

Choke

When tilting the choke lever ❷ upwards, a bore is opened in the carburetor, which enables the engine to take additional fuel. This creates a rich fuel air mixture, that is needed for a cold start.

Tilting the choke lever downwards closes the bore again.

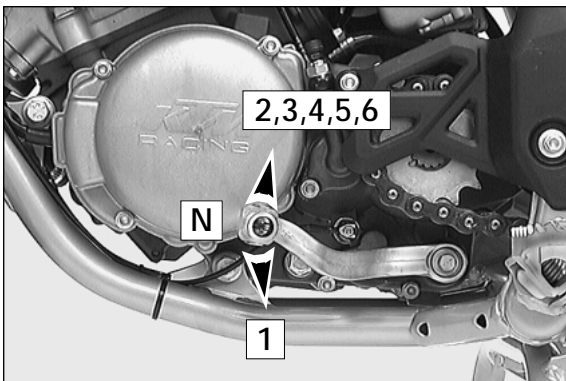

Shift lever

The shift lever is mounted on the left side of the engine. The position of the gears is shown in the illustration. Neutral, or the idle speed, is located between first and second gear.

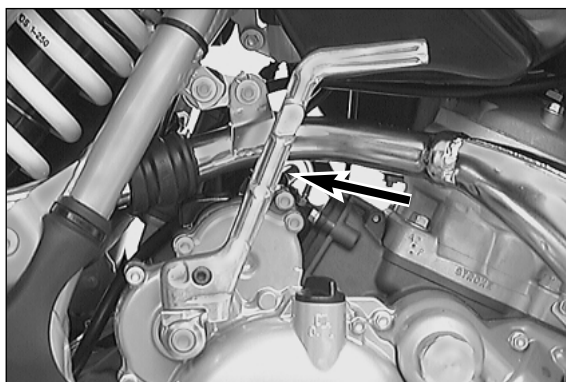

Kickstarter

The kickstarter is mounted on the left side of the engine. Its upper part can be swivelled.

⚠ WARNING ⚠

- IF YOU WANT TO START THE ENGINE, MAKE SURE THAT YOU ALWAYS PUT ON STURDY MOTORCYCLE BOOTS IN ORDER TO AVOID INJURIES. YOU MIGHT SLIP OFF THE KICKSTARTER, OR THE ENGINE MAY KICK BACK AND PROPEL YOUR FOOT UPWARD WITH GREAT VEHEMENCE.
- ALWAYS KICK KICKSTARTER BRISKLY ALL THE WAY WITHOUT OPENING THE THROTTLE. KICKING THE KICKSTARTER WITH NOT ENOUGH MOMENTUM, AND AN OPENED THROTTLE GRIP INCREASE THE KICK-BACK HAZARD.

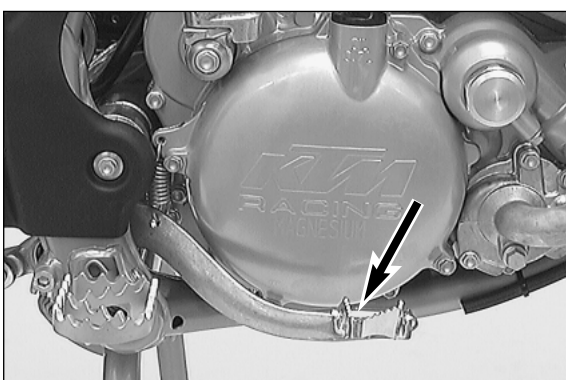

Foot brake pedal

The foot brake pedal is disposed in front of the right foot rest. Its basic position can be adjusted to your seat position (see maintenance work).

⚠ WARNING ⚠

IF THE RESISTANCE IN THE HAND BRAKE LEVER OR FOOT BRAKE PEDAL FEELS "SPONGY" (TOO MUCH GIVE), THIS IS AN INDICATION THAT SOMETHING IS WRONG WITH THE BRAKE SYSTEM. DON'T RIDE YOUR MOTORCYCLE ANYMORE WITHOUT FIRST HAVING THE BRAKE SYSTEM LOOKED OVER BY A KTM DEALER.

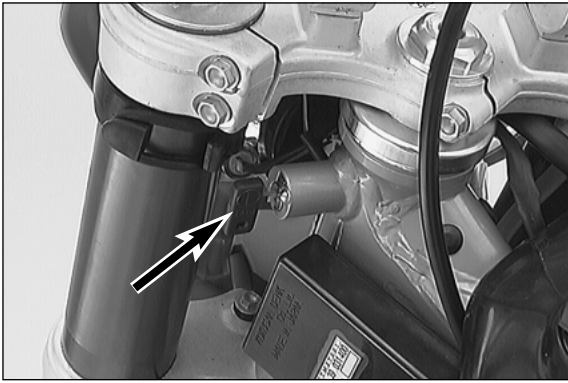

Steering lock

The handlebar can be locked by means of the lock located on the steering head. Fully turn handlebar to right to lock, insert key, turn to left, press in, turn to right and withdraw.

! **CAUTION** !

NEVER LEAVE THE KEY INSERTED IN THE STEERING LOCK. IF YOU TURN THE HANDLE BAR TO THE LEFT THE KEY COULD GET DAMAGED.

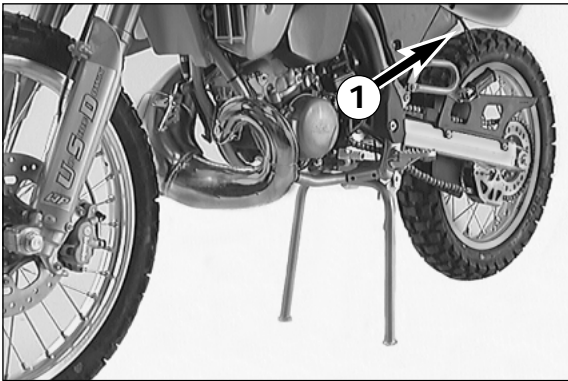

Center stand

Push center stand with your foot to the ground and pull your bike backwards. Make sure that you put your bike on solid ground and in a secure position. For off-road riding, you can use the rubber band ❶ to additionally secure the center stand in its folded-up position.

! **CAUTION** !

ALWAYS CHECK BEFORE GOING FOR A RIDE THAT YOU HAVE FOLDED UP THE CENTER STAND AS FAR AS POSSIBLE. IF THE STAND TOUCHES THE GROUND WHILE YOU ARE DRIVING, YOU MAY LOSE CONTROL OF YOUR MOTORCYCLE.



Baggage carrier

The baggage carrier may be loaded with up to 10 kg. The two lateral brackets serve as handles for the passenger

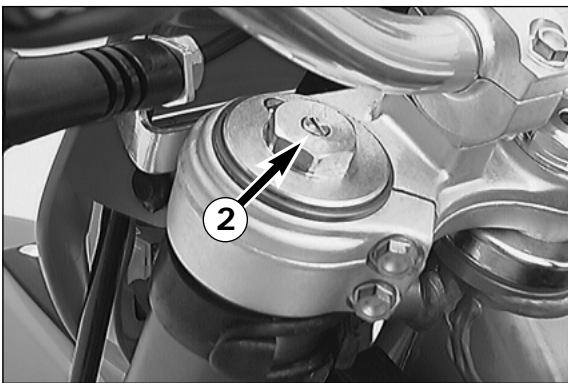

Compression damping of fork

The compression damping mechanism is built into the left fork tube. It only regulates the degree of damping during compression. By turning the adjusting screw ❷ (COM), the degree of damping of the compression can be adjusted. Turn the knob clockwise to increase damping, turn it counterclockwise to reduce damping during compression.

STANDARD ADJUSTMENT

- turn adjusting screw clockwise as far as it will go
- turn it back by as many clicks as are specified for the relevant type of fork

WP 0618T777A10 clicks

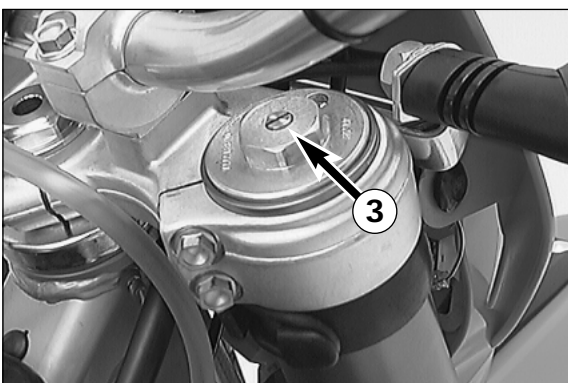

Rebound damping of fork

The rebound damping mechanism is built into the right fork tube. It only regulates the degree of damping during rebounding. By turning the adjusting screw ❸ (REB), the degree of damping of the rebound can be adjusted. Turn the knob clockwise to increase damping, turn it counterclockwise to reduce damping during rebounding.

STANDARD ADJUSTMENT

- turn adjusting screw clockwise as far as it will go
- turn it back by as many clicks as are specified for the relevant type of fork

WP 0618T777A9 clicks

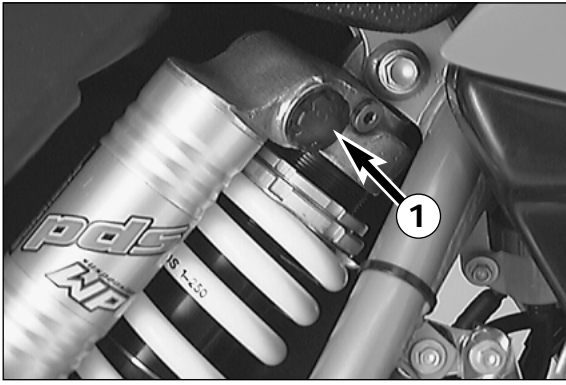

Compression damping of shock absorber

The damping force of the compression damping can be adjusted with knob ❶. The higher the number the higher the damping force.

STANDARD ADJUSTMENT:
WP 1218T715.....3 clicks



WARNING



THE DAMPING UNIT OF THE SHOCK ABSORBER IS FILLED WITH HIGH-COMPRESSION NITROGEN. NEVER TRY TO TAKE THE SHOCK ABSORBER APART OR TO DO ANY MAINTENANCE WORK YOURSELF. SEVERE INJURIES COULD BE THE RESULT.

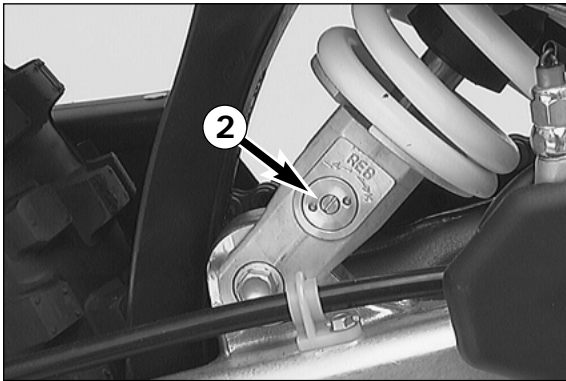

Rebound damping of shock absorber

By using the adjusting screw ❷, the degree of damping of the rebound can be adjusted. Turn the knob to the right side to increase damping, turn it to the left side to reduce damping during rebounding.

STANDARD ADJUSTMENT:
- Turn the adjusting screw clockwise to the stop.
- Then turn the adjusting screw counterclockwise, counting the number of clicks that corresponds to the respective type of shock absorber.
WP 1218T715.....14 clicks

Check the following before each start

When you start off, the motorcycle must be in a perfect technical condition. For safety reasons, you should make a habit of performing an overall check of your motorcycle before each start.

The following checks should be performed:

- 1 OIL LEVEL IN OIL TANK
Once there is no two-stroke oil in the oil tank, the engine is bound to break down. The vent hose of the oil tank must be installed without kinks.
- 2 GEAR OIL LEVEL
Insufficient amounts of oil in the transmission will lead to premature wear and subsequently to transmission failure.
- 3 FUEL
Check that there is sufficient fuel in the tank.
- 4 CHAIN
A loose chain can fall off; an extremely worn chain can tear, and insufficient lubrication can result in unnecessary wear to the chain and rear sprockets.
- 5 TIRES
Check for damaged tires. Tires showing cuts or dents must be replaced. The tread depth must comply with the legal regulations. Also check the air pressure. Insufficient tread and incorrect air pressure reduce the driving performance.
- 6 BRAKES
Check correct functioning of the braking system. Check for sufficient brake fluid in the reservoir. If the level of brake fluid falls below the minimum value, this indicates a leak in the braking system or completely worn out brake pads. Arrange for the braking system to be checked by a KTM specialist garage, as complete failure of the braking system can be expected.
Also check the state of the brake hoses and the thickness of the brake linings. Brake linings measured at their thinnest point should not be less than 1 mm since extremely worn linings can lead to brake failure.
- 7 CABLES
Check correct setting and easy running of all control cables.
- 8 COOLING LIQUID
Check the level of cooling liquid when the engine is cold.
- 9 ELECTRICAL SYSTEM
Check correct functioning and adjustment of headlights, parking light, tail-lights, brake lights, flashers, indicator lamps, horn and emergency OFF switch while the engine is running.
- 10 LUGGAGE
If you are taking luggage with you, check that this is securely fastened.



WARNING



- WEAR SUITABLE CLOTHING WHEN DRIVING A MOTORCYCLE. CLEVER KTM DRIVERS ALWAYS WEAR A HELMET, BOOTS, GLOVES AND A JACKET, REGARDLESS OF WHETHER DRIVING ALL DAY OR JUST FOR A SHORT TRIP. THE PROTECTIVE CLOTHING SHOULD BE BRIGHTLY COLOURED SO THAT OTHER USERS OF THE ROADS CAN SEE YOU AS EARLY AS POSSIBLE. YOUR PASSENGER OF COURSE WILL ALSO NEED SUITABLE PROTECTIVE CLOTHING.
- DO NOT DRIVE AFTER HAVING CONSUMED ALCOHOL.
- ONLY USE ACCESSORIES THAT HAVE BEEN RELEASED BY KTM. FOR EXAMPLE, FRONT PANNELLING CAN IMPAIR THE DRIVING PROPERTIES OF THE MOTORCYCLE. CASES, EXTRA TANKS ETC. CAN ALTER THE WEIGHT DISTRIBUTION AND THUS ALSO IMPAIR THE VEHICLE'S DRIVING PROPERTIES.
- THE FRONT AND REAR WHEEL ARE ONLY ALLOWED TO BE TIRED WITH TIRES THAT HAVE THE SAME PROFILE TYPE.

- Read the entire manual carefully before your first drive.
- Familiarize yourself with the operating elements.
- Adjust the foot brake pedal to the most comfortable positions for you.
- Get used to handling the motorcycle on an empty car park, before starting on a longer drive. Also try to drive as slowly as possible and in standing position, to improve your feeling for the vehicle.
- Hold the handlebar with both hands and leave your feet on the foot rests while driving.
- Remove your foot from the foot brake pedal when you are not braking. If the foot brake pedal is not released the brake pads rub continuously and the braking system is overheated.
- You may only be accompanied by a passenger if your motorcycle is fitted and registered for such purposes. The passenger must hold tight to the brackets or hold on to the driver during the drive, with his feet on the passenger foot rests.
- Do not make any alterations to the motorcycle and always use ORIGINAL KTM SPARE PARTS. Spare parts from other manufacturers can impair the safety of the motorcycle.
- Motorcycles are sensitive to alterations in the distribution of weight. If you are taking luggage with you, this should be secured as close as possible to the middle of the vehicle; distribute the weight evenly between the front and rear wheel. Never exceed the maximum permissible laden weight and the axle weights. The maximum permissible laden weight is made up of the following components:
 - Motorcycle ready for operation and tank full
 - Luggage
 - Driver and passenger with protective clothing and helmet.
- Pay attention to running in instructions.

Running in

- EVEN VERY PRECISELY MACHINED SECTIONS OF ENGINE COMPONENTS HAVE ROUGHER SURFACES THAN COMPONENTS WHICH HAVE BEEN SLIDING ACROSS ONE ANOTHER FOR QUITE SOME TIME. THEREFORE, EVERY ENGINE NEEDS TO BE BROKEN IN. FOR THIS REASON, DURING ITS FIRST 500 KILOMETERS (300 MILES) OR 5 HOURS THE ENGINE MUST NOT BE REVVED UP TO ITS PERFORMANCE LIMITS.
- APPLY LOW BUT CHANGING LOADS FOR RUNNING-IN.
- DO NOT DRIVE AT FULL LOAD FOR THE FIRST 500 KILOMETERS (300 MILES) OR 5 HOURS!

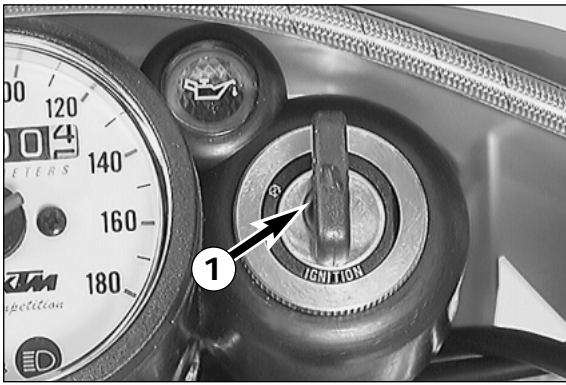

Starting when the engine is cold

- Open the fuel tap
- Turn on the ignition (ignition key ❶ position: ○).
- Switch the gear to NEUTRAL
- Operate the choke lever ❷.
- Swing up the stand.
- Push the kick starter ❸ right the way down without accelerating.
- When the engine has started but does not run smoothly, the choke lever should be tilted to its downward position.

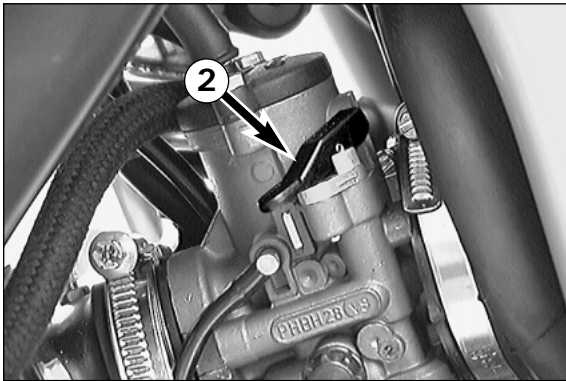

-
- ⚠ WARNING ⚠**
- If YOU WANT TO START THE ENGINE, MAKE SURE THAT YOU ALWAYS PUT ON STURDY MOTORCYCLE BOOTS IN ORDER TO AVOID INJURIES. YOU MIGHT SLIP OFF THE KICKSTARTER, OR THE ENGINE MAY KICK BACK AND PROPEL YOUR FOOT UPWARD WITH GREAT VEHEMENCE.
 - ALWAYS KICK KICKSTARTER BRISKLY ALL THE WAY WITHOUT OPENING THE THROTTLE. KICKING THE KICKSTARTER WITH NOT ENOUGH MOMENTUM, AND AN OPENED THROTTLE GRIP INCREASE THE KICK-BACK HAZARD.
 - DO NOT START THE ENGINE AND ALLOW IT TO IDLE IN A CLOSED AREA. EXHAUST FUMES ARE POISONOUS AND CAN CAUSE LOSS OF CONSCIOUSNESS AND DEATH. ALWAYS PROVIDE ADEQUATE VENTILATION WHILE THE ENGINE IS RUNNING.

! CAUTION !

DON'T RIDE YOUR MOTORCYCLE WITH FULL LOAD AND DON'T REV ENGINE WHEN COLD. BECAUSE THE PISTON IS WARMING UP FASTER THAN THE WATER COOLED CYLINDER, IT CAN CAUSE ENGINE DAMAGE. ALWAYS KEEP IN MIND THAT THE ENGINE SHOULD BE WARMED UP WITH SMALL LOAD AT MEDIUM R.P.M.

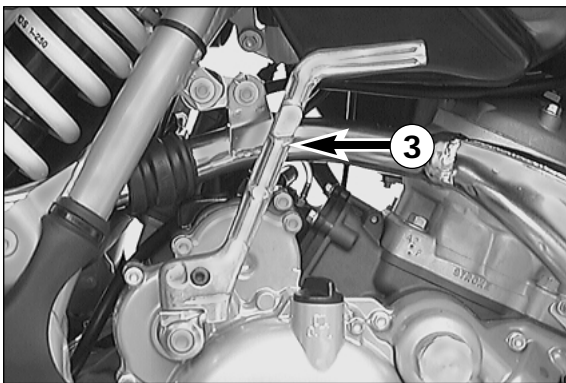

Starting when the engine is warm

- Open the fuel tap
- Turn on the ignition (ignition key ❶ position: ○).
- Switch the gear to NEUTRAL
- Swing up the stand.
- Turn up the throttle a bit and actuate the kick-starter ❸ hard ALL THE WAY.

What to do when the engine is „flooded“

The throttle must be fully opened when starting.

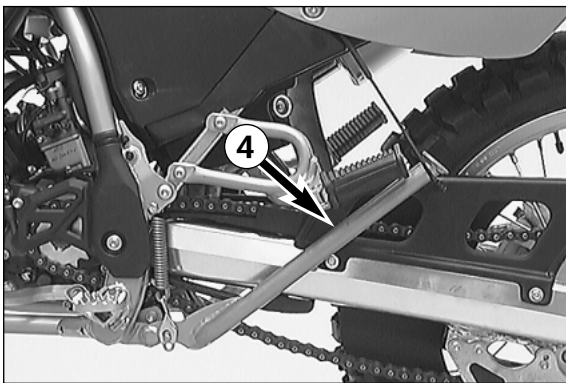

Starting off

Pull the clutch lever. Put the engine into first gear, slowly release the clutch lever and open throttle at the same time.

⚠ WARNING ⚠

BEFORE YOU START OFF, CHECK THAT THE STAND ❷ HAS BEEN SWUNG RIGHT UP TO THE TOP. IF THE STAND DRAGS ON THE GROUND, THE MOTORCYCLE CAN GO OUT OF CONTROL.

Shifting/Riding

You are now in first gear, referred to as the drive or uphill gear. Depending on the conditions (traffic, road gradient, etc.), you can shift to a higher gear. Close throttle, at the same time pull clutch lever and shift to the next higher gear. Let clutch lever go again and open throttle. If you turned on the choke, make sure you turn it off again as soon as engine is warm.

When you reach full speed through turning the throttle grip all the way, turn throttle back to 3/4; the speed hardly decreases although the engine will use less gas. Never open the throttle wider than the engine can handle. Excessive turning of the throttle grip will increase full consumption.

By shifting down, use the brakes if necessary and close throttle at the same time. Pull clutch lever and shift down to the next gear. Let clutch lever go slowly and open throttle or shift down again.

If the engine is killed f.ex. at a crossing, simply pull the clutch lever and start. It is not necessary to switch the gear to NEUTRAL.

⚠ WARNING ⚠

- OBSERVE THE TRAFFIC REGULATIONS, DRIVE DEFENSIVELY AND TRYING TO LOOK AHEAD AS FAR AS POSSIBLE SO THAT ANY HAZARDS CAN BE RECOGNIZED AS EARLY AS POSSIBLE.
- ADJUST YOUR DRIVING SPEED ACCORDING TO THE CONDITIONS AND YOUR DRIVING SKILLS.
- DRIVE CAREFULLY ON UNKNOWN ROADS
- REPLACE THE HELMET VISOR RESPECTIVELY GOGGLE GLASSES IN PLENTY OF TIME. WHEN LIGHT SHINES DIRECTLY ON SCRATCHED VISOR OR GOGGLES, YOU WILL BE PRACTICALLY BLIND.
- AFTER FALLING WITH THE MOTORCYCLE, CHECK ALL FUNCTIONS THOROUGHLY BEFORE STARTING UP OPERATIONS AGAIN.

! CAUTION !

- HIGH RPM RATES WHEN THE ENGINE IS COLD HAVE AN ADVERSE EFFECT ON THE LIFE OF YOUR ENGINE. WE RECOMMEND YOU RUN THE ENGINE IN A MODERATE RPM RANGE FOR A FEW MILES GIVING IT A CHANCE TO WARM UP. AFTER THAT NO FURTHER PRECAUTIONS IN THIS RESPECT NEED BE TAKEN.
- NEVER HAVE THE THROTTLE WIDE OPEN WHEN CHANGING DOWN TO A LOWER GEAR. THE ENGINE WILL OVERSPEED, DAMAGING THE VALVES. IN ADDITION, THE REAR WHEEL BLOCKS SO THAT THE MOTORCYCLE CAN EASILY GET OUT OF CONTROL.
- IF DURING EXTENDED DOWNHILL RIDES THE ENGINE IS RUNNING ALONG WITHOUT ANY ACTUATION OF THE THROTTLE, YOU HAVE TO TURN UP THE THROTTLE A BIT ONCE IN A WHILE TO MAKE SURE THAT ENOUGH ENGINE OIL IS FED TO THE ENGINE.
- IF THE RED OIL LEVEL WARNING LAMP LIGHT UP, IT WILL BE NECESSARY TO REFILL THE OIL TANK WITH TWO-STROKE ENGINE OIL DURING THE NEXT 100 KILOMETERS (SEE PAGE 5).
- OIL PUMP AND OIL LINES MUST BE BLED WHENEVER THE OIL TANK WAS COMPLETELY EMPTIED (SEE BLEEDING THE OIL PUMP). OTHERWISE THE OIL PUMP WILL NOT DELIVER OIL, THUS CAUSING ENGINE DAMAGE.
- IN THE EVENT THAT, WHILE RIDING ON YOUR MOTORCYCLE, YOU NOTICE ANY UNUSUAL OPERATION-RELATED NOISE, STOP IMMEDIATELY, TURN THE ENGINE OFF, AND CONTACT AN AUTHORIZED KTM DEALER.

NOTE TO THE COOLING SYSTEM

If little or no air blows through the radiator, for example when riding through slow traffic or waiting at traffic lights, the coolant temperature will rise and the cooling liquid will discharge from the radiator overflow. If possible, you should ride on fairly fast so that enough air blows through the radiators. If this is not possible however, the engine should be turned off. Let the engine cool down before you check the cooling system.

! CAUTION !

IF THE COOLING SYSTEM OVERHEATS IT MOST LIKELY SUGGESTS A DEFECT IN THE SYSTEM. IN THIS CASE, STOP IMMEDIATELY, SINCE OTHERWISE YOU MAY DAMAGE YOUR ENGINE. LET YOUR ENGINE COOL DOWN, CHECK THE COOLING SYSTEM FOR LEAKS, AND CHECK THE COOLANT LEVEL. CAUTION - SCALDING HAZARD! DO NOT DRIVE ON, UNTIL THERE IS SUFFICIENT LIQUID IN THE COOLING SYSTEM.

⚠ WARNING ⚠

IF THE RADIATOR CAP IS REMOVED WHEN THE ENGINE IS HOT, HOT COOLING LIQUID, THAT IS UNDER PRESSURE, CAN SPRAY OUT AND CAUSE SEVERE BURNS. ALLOW YOUR ENGINE TO COOL DOWN AND, IN THE MEANTIME, CHECK THE COOLING SYSTEM FOR LEAKS.

Braking

Close throttle and apply the hand and foot brakes at the same time. When driving on sandy, wet or slippery ground use mainly the rear wheel brake. Always brake with feeling, blocking wheels can cause you to skid or fall. Also change down to lower gears depending on your speed.

⚠ WARNING ⚠

WHEN YOU BRAKE, THE BRAKE DISCS, BRAKE PADS, BRAKE CALIPER AND BRAKE FLUID HEAT UP. THE HOTTER THESE PARTS GET, THE WEAKER THE BRAKING EFFECT. IN EXTREME CASES, THE ENTIRE BRAKING SYSTEM CAN FAIL.

Stopping and parking

Apply the brakes fully and put the engine into neutral. To stop the engine, switch off the ignition. Close fuel taps. Park on solid ground and lock the vehicle.

⚠ WARNING ⚠

- NEVER LEAVE YOUR MOTORCYCLE WITHOUT SUPERVISION AS LONG AS THE ENGINE IS RUNNING.
- MOTORCYCLE ENGINES PRODUCE A GREAT AMOUNT OF HEAT WHILE RUNNING. THE ENGINE, THE RADIATORS, EXHAUST SYSTEM, MUFFLER, BRAKE DISCS, AND SHOCK ABSORBERS CAN BECOME VERY HOT. DO NOT TOUCH ANY OF THESE PARTS AFTER OPERATING THE MOTORCYCLE, AND TAKE CARE TO PARK IT WHERE PEDESTRIANS ARE NOT LIKELY TO TOUCH IT AND GET BURNED.
- NEVER PARK YOUR MOTORCYCLE IN PLACES WHERE THERE EXIST FIRE HAZARDS DUE TO DRY GRASS OR OTHER EASILY FLAMMABLE MATERIALS.

! CAUTION !

- ALWAYS USE THE IGNITION LOCK TO TURN OFF THE ENGINE. WHEN YOU TURN OFF THE ENGINE WITH THE SHORT CIRCUIT BUTTON AND LEAVE THE IGNITION ON, THE PARKING LIGHT WILL LIGHT UP.
- WHEN PARKING YOUR MOTORCYCLE ALWAYS CLOSE FUEL TAP. WITH THE FUEL TAP OPEN, THE CARBURETOR MIGHT OVERFLOW AND FUEL COULD FLOW INTO THE ENGINE.
- ALWAYS TAKE OUT THE IGNITION KEY WHEN PARKING YOUR MOTORCYCLE SO THAT IT CANNOT BE USED BY UNAUTHORIZED PERSONS.
- PARK YOUR MOTORCYCLE, SO THAT IT RESTS STABLY ON THE STAND (HARD GROUND, LEVEL SURFACE) AND CAN'T TIP OVER.

A washed motorcycle can be checked more quickly which saves money!

 1. Service after
1000 km

 2. Service after
4000 km

 every
4000 km
or
once a year

		1. Service after 1000 km	2. Service after 4000 km	every 4000 km or once a year
ENGINE	Check oil level in oil tank and verify kink-less arrangement of bleeder hose	●	●	●
	Change transmission oil	●	●	●
	Check spark plug, set electrode gap, replace plug if necessary		●	
CARBURETOR	Check carburetor connection boots for cracks and leaks		●	●
	Check idle setting and emission values	●	●	●
	Check bleeder hoses for damage and kink-free arrangement	●	●	●
ADD-ON-PARTS	Check cooling system for leaks, antifreeze protection	●	●	●
	Check exhaust system for leaks and suspension		●	●
	Check actuating cables for damage, smooth operation, and kink-less arrangement, and adjust and lubricate	●	●	●
	Check oil level in master cylinder of hydraulic clutch	●	●	●
	Clean air filter and air filter box		●	●
	Check cables for damage and kink-less arrangement		●	●
	Check headlamp adjustment		●	●
	Check electrical system for proper operation (low/high beams, stop light, turn indicators, tell-tale lamps, speedometer illumination, horn, battery holder, and connections)	●	●	●
	Check brake fluid level, lining thickness, and brake discs	●	●	●
	Check brake lines for damage and leaks	●	●	●
BRAKES	Check/adjust smooth operation, free travel of handbrake/footbrake levers	●	●	●
	Check screws of brake system for tight fit	●	●	●
	Check suspension strut and fork for leaks and proper function	●	●	●
	Clean fork dust sleeves		●	●
CHASSIS	Bleed fork legs		●	●
	Check swinging-fork pivot		●	●
	Check/adjust steering-head bearing	●	●	●
	Check all chassis screws for tight fit (fork plates, fork leg, axle nuts/screws, swinging-fork pivot, suspension strut)	●	●	●
	Check spoke tension and rim joint		●	●
WHEELS	Check tire condition and inflation pressure	●	●	●
	Check chain, chain wheels, chain wheel guides for wear, tight fit, and tension	●	●	●
	Lubricate chain	●	●	●
	Check wheel bearings for play	●	●	●

IMPORTANT RECOMMENDED MAINTENANCE PROCEDURES TO BE PERFORMED BASED ON A SEPARATE SUPPLEMENTARY ORDER

	at least once a year	every 2 year or 20000 km
Verify proper function of exhaust control	●	
Perform complete fork maintenance		●
Perform complete suspension strut maintenance		●
Clean and lubricate the steering-head bearing and sealing elements	●	
Clean and adjust the carburetor	●	
Replace the glass-fiber yarn packing of the main silencer		●
Treat the electrical contacts and switches with contact spray	●	
Replace the oil of the hydraulic clutch	●	
Replace the brake fluid	●	

SERVICE INTERVALLS SHOULD NEVER BE EXCEED BY MORE THAN 500 KM!
MAINTENANCE WORK DONE BY KTM AUTHORISED WORKSHOPS IS NOT A SUBSTITUTE OF CARE AND CHECKS DONE BY THE RIDER!

IMPORTANT CHECKS AND MAINTENANCE TO BE CARRIED OUT BY THE RIDER

	Before each start	After every cleaning	For cross-country use	Once a year
Check oil level in oil tank and bleeder hose for its kink-less arrangement	●			
Check transmission oil level	●			
Check brake fluid level	●			
Check brake pads for wear	●			
Check lighting system for proper operation	●			
Check horn for proper operation	●			
Lubricate and adjust actuating cables and nipples		●		
Bleed fork legs in regular intervals			●	
Remove and clean fork dust sleeves in regular intervals			●	
Clean and lubricate chain, check tension and readjust it if necessary		●	●	
Clean air filter and filter box			●	
Check tire inflation pressure and wear	●			
Check coolant level	●			
Check fuel lines for leaks	●			
Drain and clean float chamber		●		
Verify smooth operation of all controls	●			
Check brake performance	●	●		
Treat exposed metal components (except for brake and exhaust systems) with wax-based anti-corrosion agents		●		
Treat ignition/steering lock and light switch with contact spray		●		
Check all screws, nuts, and hose clamps for their tight fit in regular intervals				●

MAINTENANCE WORK ON CHASSIS AND ENGINE



WARNING



ALL MAINTENANCE AND ADJUSTMENT OPERATIONS THAT ARE MARKED WITH A * REQUIRE SPECIALIST KNOWLEDGE. FOR YOUR OWN SAFETY, LET THESE TASKS BE CARRIED OUT BY A KTM-DEALER



CAUTION



- WHEN CLEANING THE MOTORCYCLE, DO NOT USE A HIGH PRESSURE CLEANING UNIT IF POSSIBLE, OTHERWISE WATER WILL PENETRATE THE BEARINGS, CARBURETOR, ELECTRIC CONNECTORS ETC.
- LET YOUR MOTORCYCLE COOL DOWN BEFORE BEGINNING ANY MAINTENANCE WORK IN ORDER TO AVOID GETTING BURNED.
- DISPOSE OF OIL, GREASE, FILTERS, FUELS, CLEANING AGENTS ETC. ACCORDING TO YOUR LOCAL REGULATIONS.
- UNDER NO CIRCUMSTANCES MAY USED OIL BE DISPOSED OF IN THE SEWAGE SYSTEM OR IN THE OPEN COUNTRYSIDE. 1 LITER USED OIL CONTAMINATES 1.000.000 LITERS WATER.

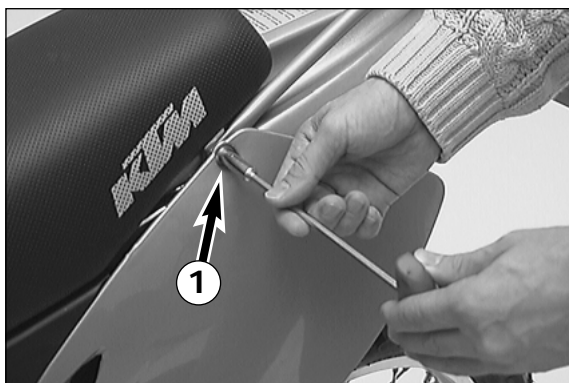

Dismounting and mounting of seat

Remove left and right screws ❶. Lift rear portion of seat, pull it backwards, and disengage it at the oval head screw ❷.

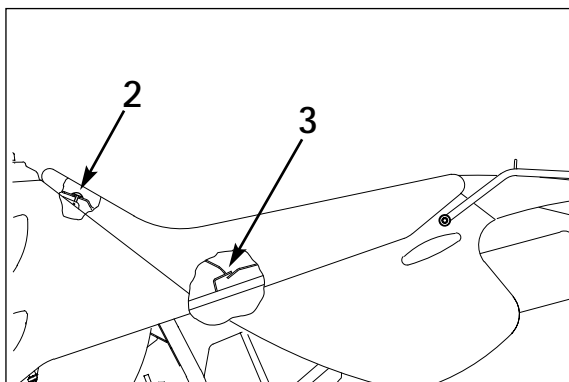

Mounting the seat:

Hook the seat onto the oval head screw ❷.

Slide it forward to let the retaining plate ❸ engage in the seat.

Slide retaining shackles of seat under the side covers and mount screws ❶

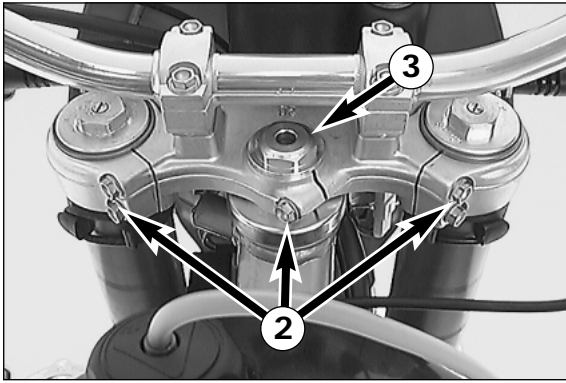

Checking and adjusting the steering head bearing *

Check steering head bearing for play periodically. For check put motorcycle on stand so that the front wheel is off the ground. Now try to move the fork forward and backward. For readjusting, loosen the five pinch bolts ② of the top triple clamp and turn steering stem bolt clockwise ③ until there is no more play. Don't tighten the steering stem bolt all the way, otherwise the bearings will be damaged. With a plastic hammer, lightly rap on the triple clamp to release tension. Retighten the five pinch bolts to 20 Nm (15 ft.lb).



WARNING



IF THE STEERING HEAD BEARING IS NOT ADJUSTED TO BE FREE OF PLAY, THE MOTORCYCLE WILL EXHIBIT UNSTEADY DRIVING CHARACTERISTICS AND CAN GET OUT OF CONTROL.



CAUTION



IF YOU DRIVE WITH PLAY IN THE STEERING HEAD BEARING FOR LONGER PERIODS, THE BEARINGS AND SUBSEQUENTLY THE BEARING SEATS IN THE FRAME WILL BE DESTROYED.

The steering head bearings should be regreased at least once a year (i.e. Shell Advance Grease).

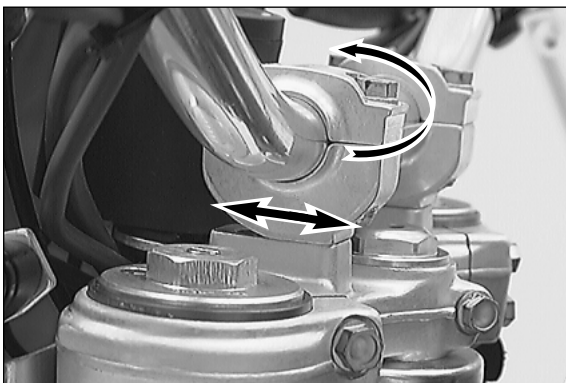
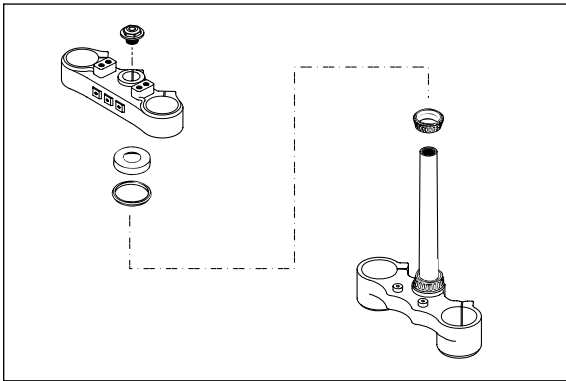

How to change the handlebar position

The handlebar position can be readjusted by 22 mm. Thus, you can put the handlebar to the position that is the most convenient for you. The upper triple clamp ④ includes 2 bores arranged at a distance of 15 mm (0,6 in) from one another. The bores at the handlebar support ⑤ are offset from the center by 3.5 mm (0,13 in). Accordingly, you can mount the handlebar in 4 different positions.

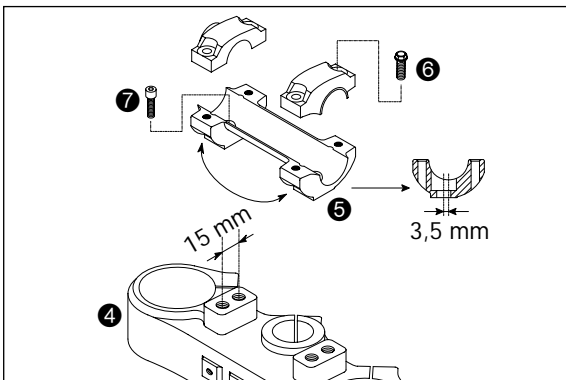

For this purpose, remove screws ⑥ of the handlebar clamps and screws ⑦ of the handlebar support. Position handlebar support, and tighten screws ⑦ to 40 Nm (30 ft.lbs). Mount handlebar and handlebar clamps, and tighten screws ⑥ to 20 Nm (15 ft.lbs). The gap between handlebar support and handlebar clamps is to be of equal size in the front and in the rear.

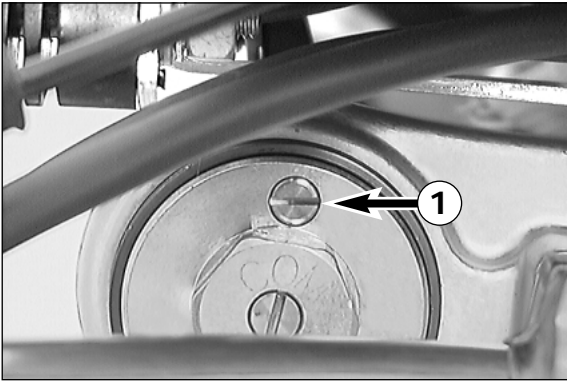

Breather plug front fork

After every 5 hours of use for competitive racing, slacken the breather plugs **1** a few turns in order to relieve excess pressure from the inside of the fork. To do this, place the motorcycle on a stand with the front wheel lifted off the ground. When riding the motorcycle mainly on street, it will be enough to have this job performed in the course of the periodical maintenance service.

! CAUTION !

EXCESSIVE PRESSURE IN THE INTERIOR OF THE FORK CAN CAUSE LEAKS IN THE FORK. IF YOUR FORK IS LEAKING, IT IS RECOMMENDED TO OPEN THE BREATHER PLUGS BEFORE HAVING THE SEALS REPLACED.

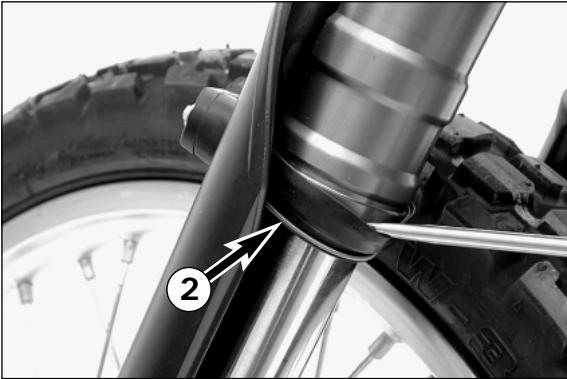

Cleaning the dust sleeves of the telescopic fork

The dust-protection bellows **2** are to remove dust and coarse dirt particles from the fork tube. However, after some time, dirt may also get in behind the dust-protection bellows. If this dirt is not removed, the oil sealing rings located behind it may start to leak.

Use a screwdriver to lever the dust-protection bellows from the outer tubes and slide them downward.

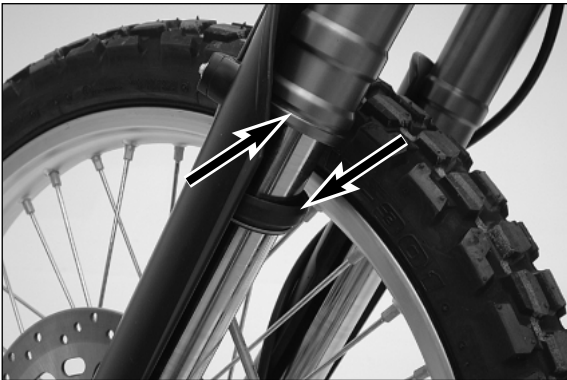

Clean dust-protection bellows, outer tubes, and fork tubes thoroughly, and oil them thoroughly with silicone spray or engine oil. Then, push dust-protection bellows into the outer tubes by hand.

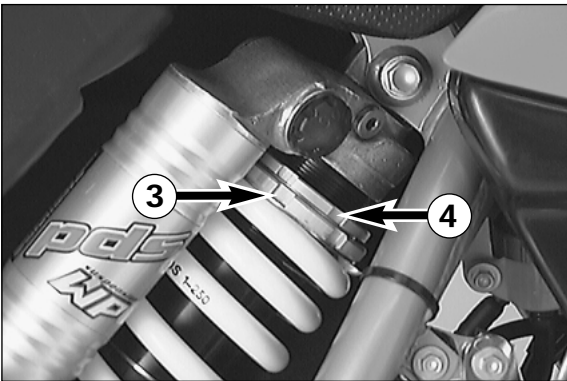

Changing the spring preload of the shock absorber *

KTM sets the shock absorber for driver only, weighing approximately 75 kg (165 lb). If you want to take a passenger with you, or if you weigh considerably more or less than 75 kg (165 lb), you should change the spring preload accordingly. This is easily done.

NOTE:

- Before changing the spring preload note down the basic setting, e.g. how many coils are visible above the adjusting ring.
- One rotation of the adjusting ring **3** changes the spring preload by approximately 1.5 mm.

Use the hook wrenches included in the vehicle tool kit to loosen the counter ring **4**. Change spring preload as desired by means of the adjusting ring **3**, and retighten counter ring.

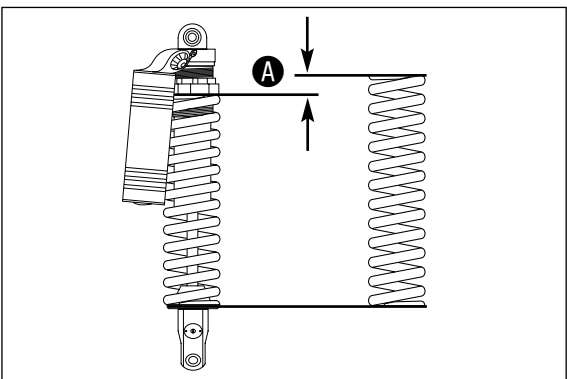

ADJUSTMENT VALUES - SPRING PRELOAD:

Minimum preload.....	10 mm
Preload driver only 75 kg BASIC SETTING	23 mm
Preload with passenger.....	28 mm

A = spring preload

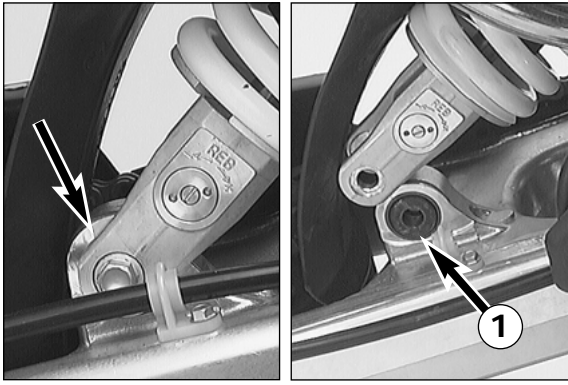

Pivot bearing

The pivot bearing ❶ for PDS suspension struts at the swinging fork is Teflon-coated and must not be lubricated with either grease or other lubricants. Grease and other lubricants cause the Teflon coat to dissolve, whereby the bearing's lifecycle will be reduced dramatically.

When cleaning your bike with a high-pressure cleaner, do not aim the high-pressure spray directly at the pivot bearing.

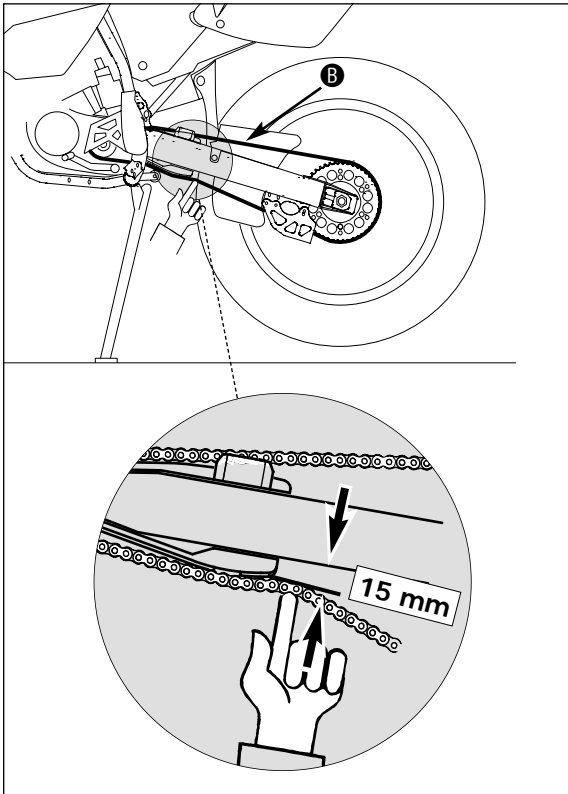

Check chain tension

To check the chain tension, park the motorcycle.

Press chain upward at the end of the chain sliding component. The distance between chain and swing arm should be approx. 15 mm (0.6 in). In the course of this procedure, the upper chain portion ❷ must be taut (see drawing).

If necessary, correct chain tension.

⚠ **WARNING** ⚠

- IF CHAIN TENSION IS TOO GREAT, PARTS WITHIN THE SECONDARY TRANSMISSION (CHAIN, CHAIN WHEELS AND REAR WHEEL BEARINGS) WILL BE SUBJECTED TO UNNECESSARY STRESS, RESULTING IN PREMATURE WEAR AND EVEN CHAIN BREAKAGE.
- TOO MUCH SLACK IN THE CHAIN, ON THE OTHER HAND, CAN RESULT IN THE CHAIN JUMPING OFF THE CHAIN WHEELS. IF THIS HAPPENS, THE CHAIN COULD ALSO BLOCK THE REAR WHEEL OR DAMAGE THE ENGINE.
- IN EITHER CASE THE OPERATOR IS LIKELY TO LOSE CONTROL OF THE MOTORCYCLE.

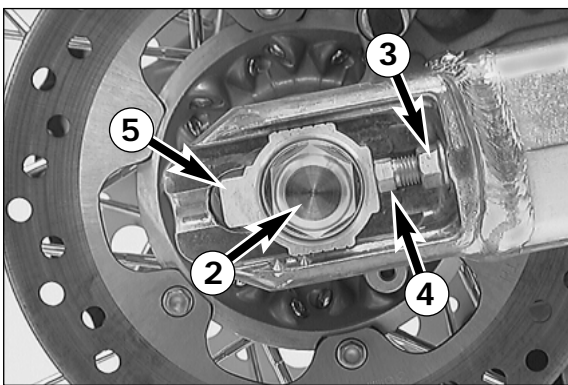

Correct chain tension

Loosen collar nut ❷, loosen lock nuts ❸, and turn right and left adjusting screws ❹ equally far. Tighten lock nuts.

Before tightening the collar nut, verify that the chain adjusters ❺ are sitting close to the adjusting screws and that the rear wheel has been aligned with the front wheel.

Tighten collar nut ❷ to 80 Nm (60 ft.lb).

⚠ **WARNING** ⚠

- IF YOU DON'T HAPPEN TO HAVE A TORQUE WRENCH AT HAND, MAKE SURE YOU HAVE THE TIGHTENING TORQUE CORRECTED BY A KTM DEALER AS SOON AS POSSIBLE. A LOOSE AXLE MAY LEAD TO AN UNSTABLE DRIVING BEHAVIOR OF YOUR MOTORCYCLE.
- TIGHTEN THE COLLAR NUT WITH THE REQUIRED TORQUE. A LOOSE WHEEL SPINDLE MAY LEAD TO AN UNSTABLE BEHAVIOR OF YOUR MOTORCYCLE.

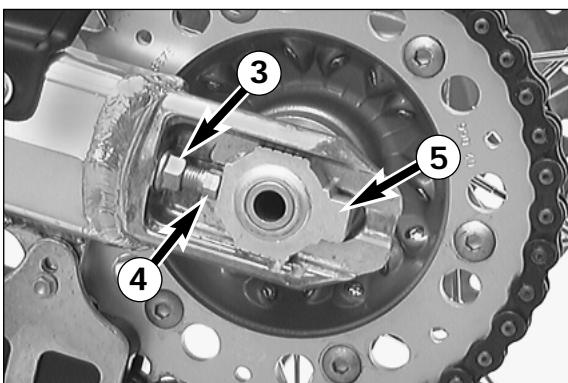

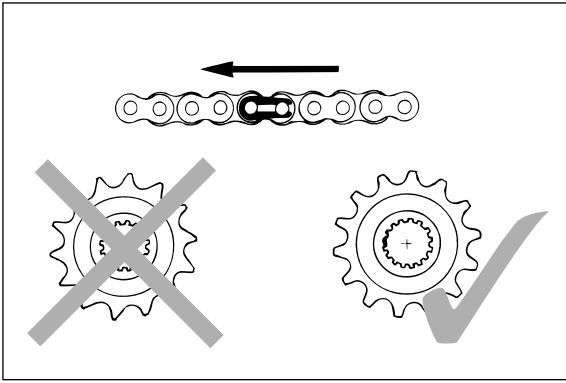

Chain maintenance

O-ring chains require only modest maintenance. The best way is to use lots of water, but never use brushes or solvents. After letting the chain dry, you can use a special O-ring chain spray (Shell Advance Bio Chain).



WARNING



NO LUBRICATION IS ALLOWED TO REACH THE REAR TIRE OR THE BRAKE DISKS, OTHERWISE THE ROAD ADHERENCE AND THE REAR WHEEL BRAKING EFFECTS WOULD BE STRONGLY REDUCED AND THE MOTORCYCLE COULD EASILY GET OUT OF CONTROL.



CAUTION



WHEN MOUNTING THE CHAIN JOINT, THE CLOSED SIDE OF THE SAFETY DEVICE MUST POINT IN RUNNING DIRECTION.

Also check sprockets and chain guides for wear, and replace if necessary.

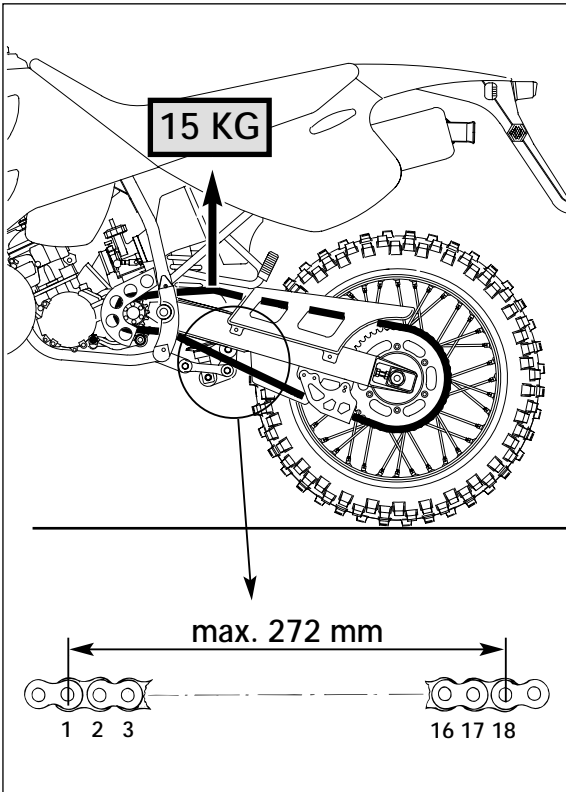

Chain wear

In order to check the chain wear, regard the following instructions: Shift the gear into idling and pull the upper chain strand with approx. 10-15 kilogramm (33 lb) upwards (see figure). Now one can measure a space of 18 chain reels at the lower chain strand. The chain should be replaced at the latest when a space of 272 mm (10,70 in) is measured. Chains do not always wear off evenly, therefore repeat the measurement at different places on the chain.

NOTE:

If you mount a new chain, the sprockets should also be replaced. New chains wear faster if used on old used sprockets.

General information about KTM disc brakes

BRAKE CALIPERS:

The brake calipers of this series use a „floating“ mount. This means that the brake calipers are not solidly attached to the caliper support, which enables them to „float“ for maximum braking contact.

BRAKE PADS:

Since KTM motorcycles are mainly designed for races under extremely dirty conditions (e.g. water in connection with sand and mud), the front wheel is equipped with brake pads with sintered lining. These linings cover almost the entire operative range of the motorcycle.

BRAKE DISCS:

Due to wear, the thickness of the brake disc in the area of the contact face ❶ of the brake pads decreases. At their thinnest point ❷, the brake discs must not be more than 0.40 mm (0,016 in) thinner than the pad's nominal thickness. Measure the nominal thickness in a location ❸ outside the contact face. Check wear in several locations.



WARNING



- BRAKE DISCS SUFFERING FROM WEAR GREATER THAN 0,4 MM (0,016 IN) CONSTITUTE A SAFETY RISK. HAVE THE BRAKE DISCS REPLACED IMMEDIATELY AS SOON AS THEY REACH THE WEAR LIMIT.
- HAVE ANY REPAIRS ON THE BRAKE SYSTEM BE PERFORMED BY A KTM DEALER

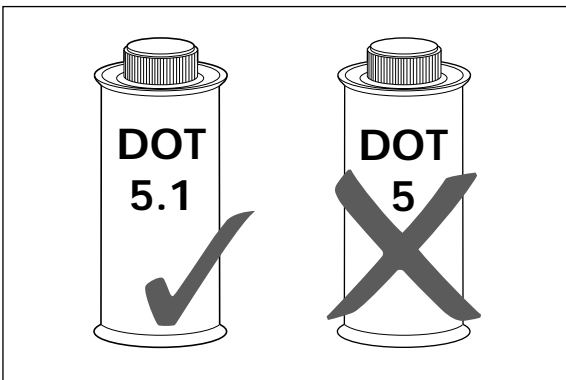

BRAKE FLUID RESERVOIRS:

The brake fluid reservoirs on front and rear wheel brakes have been designed in such a way that even if the brake pads are worn it is not necessary to top up the brake fluid. If the brake fluid level drops below the minimum level either the brake system has a leak or the brake pads are completely worn.

In this case, consult an authorized KTM dealer immediately.

BRAKE FLUID:

KTM fills the brake systems with SHELL ADVANCE BRAKE DOT 5.1 brake fluid, one of the best brake fluids that is currently available. We recommend that you continue to use it. DOT 5.1 brake fluid is based on glycol ether and of an amber color. If you do not have any DOT 5.1 for refilling, you may use DOT 4 brake fluid. However, you should replace it as soon as possible by DOT 5.1.

Never use brake fluid DOT 5. The color of this silicon oil-based product is purple red. The gaskets and brake hoses of KTM motorcycles are not designed for DOT 5 brake fluid!

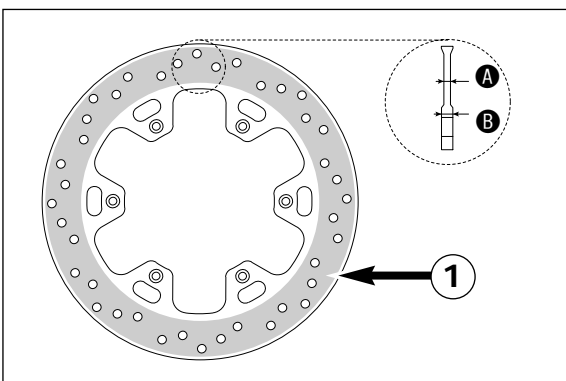

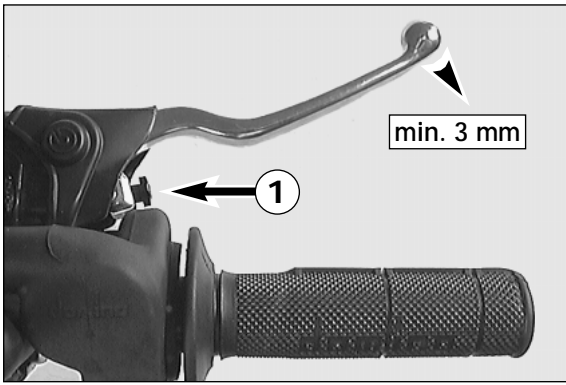

Adjusting of free travel at the hand brake lever

Free travel at the hand brake lever may be readjusted by using adjustment screw ❶. In this way, the position of the point of pressure (i.e., the resistance you feel on the hand brake lever when the brake pads are pressed against the brake disc) can be adjusted for any hand size.

! CAUTION !

AT THE HAND BRAKE LEVER, FREE TRAVEL MUST AT LEAST BE 3 MM (0.1 IN). ONLY THEN MAY THE PISTON IN THE HAND BRAKE CYLINDER BE MOVED (TO BE RECOGNIZED BY THE GREATER RESISTANCE OF THE HAND BRAKE LEVER). IF THIS FREE TRAVEL IS NOT PROVIDED, PRESSURE WILL BUILD UP IN THE BRAKING SYSTEM, AND THE FRONT-WHEEL BRAKE MAY FAIL DUE TO OVERHEATING.

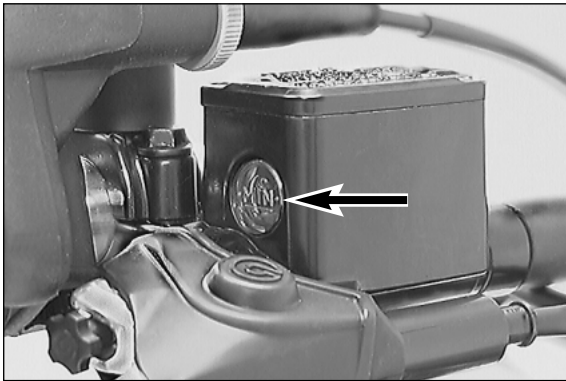

Checking of brake fluid level - front brake

The brake fluid reservoir is linked with the hand brake cylinder at the handlebar and the reservoir is provided with an inspection glass. With the reservoir in a horizontal position, the brake fluid level should not go below middle of the glass.

⚠ WARNING ⚠

IF THE BRAKE FLUID LEVEL DROPS BELOW THE MINIMUM EITHER THE BRAKE SYSTEM HAS A LEAK OR THE BRAKE PADS ARE COMPLETELY WORN DOWN. IN THIS CASE, CONSULT AN AUTHORIZED KTM DEALER IMMEDIATELY.

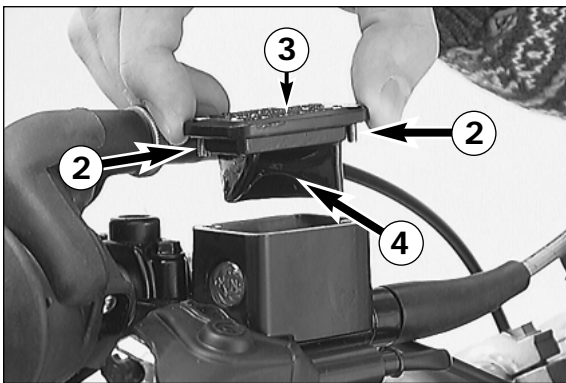

Refilling the front brake reservoir*

Loosen screws ❷ and remove lid ❸ and membrane ❹. Place hand brake cylinder in a horizontal position and fill the brake fluid reservoir to 5 mm (0.2 in) below the rim with brake fluid DOT 5.1 (Shell Advance Brake DOT 5.1). Replace membrane and lid, tighten screws. Rinse off spilled or overflowing brake fluid with water.

⚠ WARNING ⚠

- NEVER USE DOT 5 BRAKE FLUID! IT IS BASED ON SILICONE OIL AND OF A PURPLE COLOR. SEALS AND BRAKE HOSES MUST BE ESPECIALLY ADAPTED TO IT.
- STORE BRAKE FLUID OUT OF REACH OF CHILDREN.
- BRAKE FLUID CAN CAUSE SKIN IRRITATION. AVOID CONTACT WITH SKIN AND EYES. IF YOU GET BRAKE FLUID IN YOUR EYES, RINSE WITH PLENTY OF WATER AND CONSULT A DOCTOR.

! CAUTION !

- DON'T LET BRAKE FLUID GET IN CONTACT WITH PAINT, IT IS AN EFFECTIVE PAINT REMOVER.
- USE ONLY CLEAN BRAKE FLUID TAKEN FROM A TIGHTLY SEALED CONTAINER.

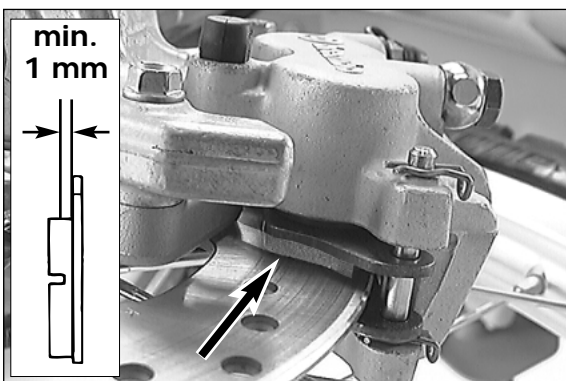
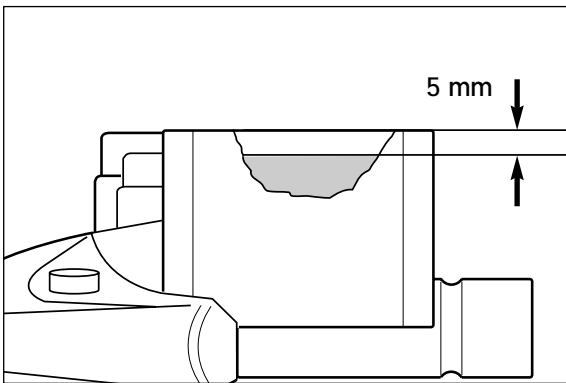

Checking the front brake pads

The brake pads can be inspected from below. The linings must be at least 1 mm (0.04 in) thick.

⚠ WARNING ⚠

AT THEIR MOST WORN POINT BRAKE PAD LININGS SHOULD NOT BE THINNER THAN 1 MM, OTHERWISE THEY COULD LEAD TO BRAKE FAILURE. FOR YOUR OWN SAFETY DON'T PUT OFF HAVING YOUR BRAKE PADS CHANGED.

! CAUTION !

IF THE BRAKE PADS ARE REPLACED TOO LATE SO THAT THE LINING IS PARTLY OR ENTIRELY WORN, THE STEEL COMPONENTS OF THE BRAKE PAD WILL RUB AGAINST THE BRAKE DISC, THEREBY IMPAIRING THE BRAKING EFFECT AND DESTROYING THE BRAKE DISC.

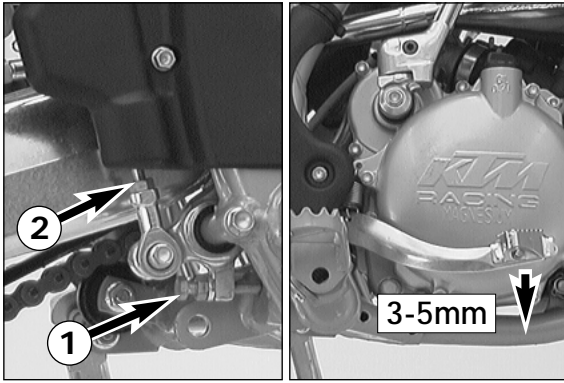

Changing the basic position of the foot brake pedal *

The basic position of the foot brake pedal can be altered by turning the stop screw ❶. The free play at the foot brake pedal must then be adjusted by means of the piston rod ❷.

Measured on the outside, the foot brake pedal must have 3-5 mm (0.12-0.20 in) of free play, before the piston rod can move the piston in the brake cylinder (to be recognised from the resistance on the foot brake pedal).

! CAUTION !

IF THIS FREE PLAY IS NOT PRESENT, THEN PRESSURE CAN BUILD UP IN THE BRAKE SYSTEM WHEN DRIVING, CAUSING THE REAR WHEEL TO BRAKE. THE BRAKING SYSTEM OVERHEATS AND MAY EVEN FAIL COMPLETELY IN EXTREME CASES.

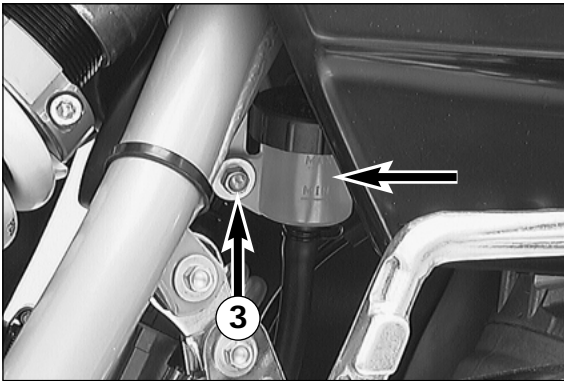

Checking rear brake fluid level

The brake fluid reservoir of the rear disc brake is located on the right side of the motorcycle next to the kickstarter. The brake fluid level must not drop below the „MIN“ marking when the vehicle is in an upright position.

⚠ WARNING ⚠

IF THE BRAKE FLUID LEVEL DROPS BELOW THE MINIMUM EITHER THE BRAKE SYSTEM HAS A LEAK OR THE BRAKE PADS ARE COMPLETELY WORN. IN THIS CASE, CONSULT AN AUTHORIZED KTM DEALER IMMEDIATELY.



Refilling the rear brake fluid reservoir *

For this purpose, it is recommended to remove screw ❸ and to pull the brake fluid reservoir outwards. Now the screw cap ❹ and the rubber boot ❺ can be removed. Add brake fluid DOT 5.1 (Shell Advance Brake DOT 5.1) until the brake fluid level reaches the „MAX“ mark, then mount the screw cap together with the rubber boot. Restore the brake fluid reservoir to its original position and fix it with the screw. The connecting hose between the reservoir and the foot brake cylinder must be carefully positioned, preventing kinks and keeping a safe distance between the hose and the exhaust pipe. Spilled brake fluid must be rinsed off with water.

⚠ WARNING ⚠

- NEVER USE DOT5 BRAKE FLUID! IT IS BASED ON SILICONE OIL AND OF A PURPLE COLOR. SEALS AND BRAKE HOSES MUST BE ESPECIALLY ADAPTED TO IT.
- STORE BRAKE FLUID OUT OF REACH OF CHILDREN.
- BRAKE FLUID CAN CAUSE SKIN IRRITATION. AVOID CONTACT WITH SKIN AND EYES. IF YOU GET BRAKE FLUID IN YOUR EYES, RINSE WITH PLENTY OF WATER AND CONSULT A DOCTOR.

! CAUTION !

- DON'T LET BRAKE FLUID GET IN CONTACT WITH PAINT, IT IS AN EFFECTIVE PAINT REMOVER.
- USE ONLY CLEAN BRAKE FLUID TAKEN FROM A TIGHTLY SEALED CONTAINER.

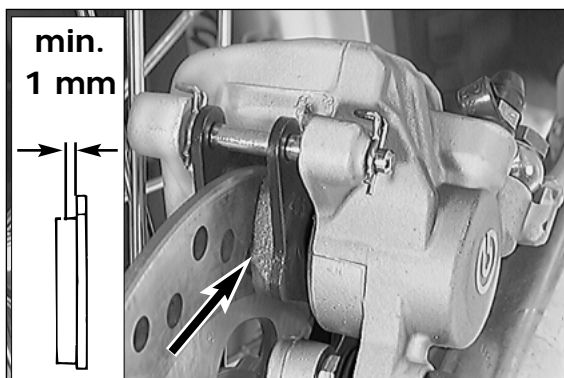
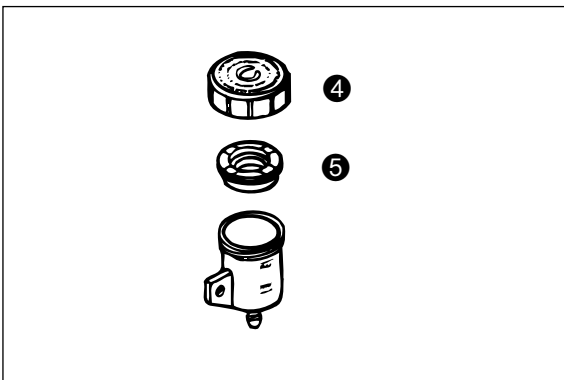

Checking the rear brake pads

The brake pads can be inspected from the rear. The thickness of the linings may not be less than 1 mm (0.04 in).

⚠ WARNING ⚠

AT THEIR MOST WORN POINT BRAKE PAD LININGS SHOULD NOT BE THINNER THAN 1 MM, OTHERWISE THEY COULD LEAD TO BRAKE FAILURE. FOR YOUR OWN SAFETY DON'T PUT OFF HAVING YOUR BRAKE PADS CHANGED.

! CAUTION !

IF THE BRAKE PADS ARE REPLACED TOO LATE SO THAT THE LINING IS PARTLY OR ENTIRELY WORN, THE STEEL COMPONENTS OF THE BRAKE PAD WILL RUB AGAINST THE BRAKE DISC, THEREBY IMPAIRING THE BRAKING EFFECT AND DESTROYING THE BRAKE DISC.

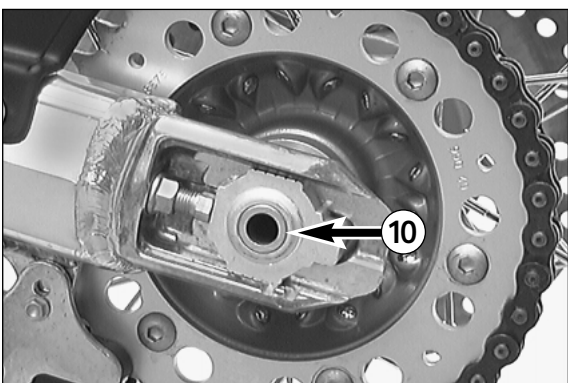
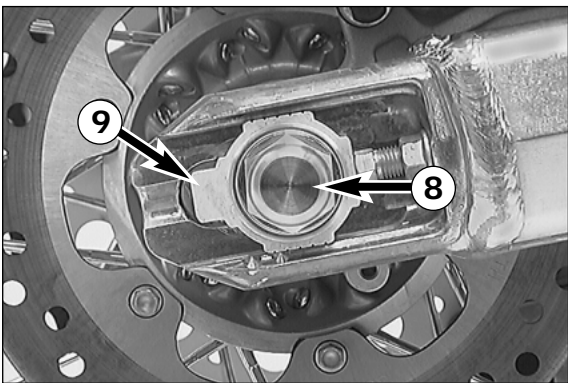
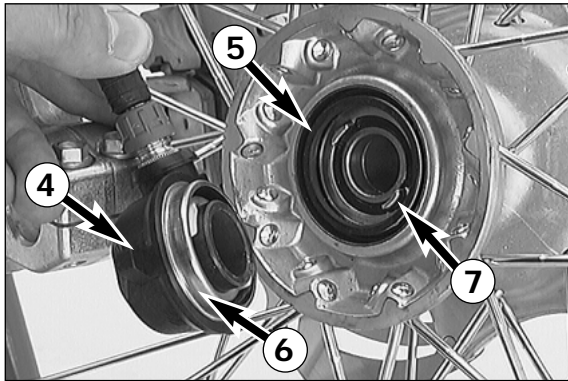
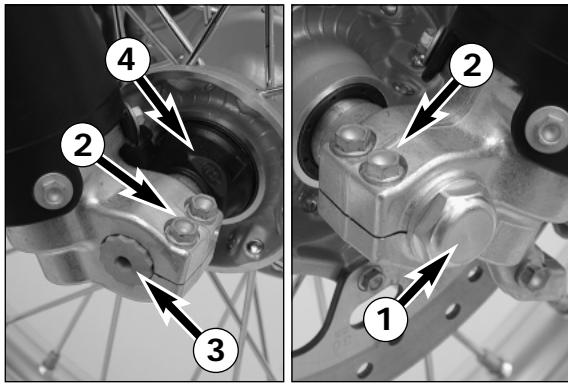

Dismounting and mounting the front wheel *

To remove the front wheel, jack the motorcycle up on its frame so that the front wheel no longer touches the ground.

Loosen both clamp screws **2** on the left fork leg. Then loosen the collar nuts **1** before loosening the clamp screws **2** on the right fork leg. Hold the front wheel and withdraw the wheel spindle **3**.

Note: The wheel spindle can be withdrawn more easily by turning it moderately with a 6 mm ALLAN/IMBUS key while pulling.

Remove front wheel carefully from the fork and take the speedometer drive **4** off the hub.

! CAUTION !

DO NOT OPERATE THE HAND BRAKE WHEN THE FRONT WHEEL HAS BEEN DISMOUNTED. ALWAYS PLACE THE WHEEL ON THE GROUND WITH THE BRAKE DISC POINTING UPWARDS. OTHERWISE THE BRAKE DISC MAY BE DAMAGED.

Prior to mounting the front wheel, clean and grease sealing ring **5** and running surface **6** at the speedometer drive.

To mount the front wheel, lift it into the fork. Insert the speedometer drive into the hub. Make sure the driving tabs **7** engage with the slots of the speedometer drive.

Position the front wheel and the speedometer drive or distance brushing and mount the wheel spindle.

Mount collar nut **1**, turn speedometer drive in a way that the flexible speedometer shaft will curve upwards in a slight bow (see pict.) and tighten collar nut to 40 Nm (30 ft.lb).

Take the motorcycle off the stand and bounce the fork hard a few times to align the fork legs.

Then tighten clamping screws **2** to a max. torque of 10 Nm (7 ft.lbs).

⚠ WARNING ⚠

- IF YOU DON'T HAPPEN TO HAVE A TORQUE WRENCH AT HAND, MAKE SURE YOU HAVE THE TIGHTENING TORQUE CORRECTED BY A KTM DEALER AS SOON AS POSSIBLE. A LOOSE AXLE MAY LEAD TO AN UNSTABLE DRIVING BEHAVIOR OF YOUR MOTORCYCLE.
- AFTER MOUNTING THE FRONT WHEEL, KEEP OPERATING THE HAND BRAKE UNTIL THE PRESSURE POINT RETURNS.
- IT IS VERY IMPORTANT TO KEEP THE BRAKE DISK FREE FROM OIL AND FATTY MATTERS, OTHERWISE THE BRAKING EFFECTS WOULD BE STRONGLY REDUCED.

Dismounting and mounting the rear wheel *

Jack the motorcycle up by the frame so that the rear wheel no longer touches the ground. Loosen the collar nut **8**, remove chain tensioner **9**, hold the rear wheel pull out the wheel spindle **10** until the rear wheel is free but the brake caliper support is still held. Push the rear wheel as far forward as possible, take the chain from the chain sprocket and carefully take the rear wheel out of the swing arm.

! CAUTION !

- DO NOT OPERATE THE FOOT BRAKE WHEN THE REAR WHEEL HAS BEEN DISMOUNTED.
- WHEN THE WHEEL SPINDLE IS DISMOUNTED, CLEAN THE THREADS OF THE WHEEL SPINDLE AND COLLAR NUT THOROUGHLY AND APPLY A NEW COAT OF GREASE TO PREVENT THE THREAD FROM JAMMING.

The rear wheel is remounted in reverse order. Before tightening the collar nut with 80 Nm (60 ft.lb), push the rear wheel forwards so that the chain tensioners lie on the tension screws.

⚠ WARNING ⚠

- IF YOU DON'T HAPPEN TO HAVE A TORQUE WRENCH AT HAND, MAKE SURE YOU HAVE THE TIGHTENING TORQUE CORRECTED BY A KTM DEALER AS SOON AS POSSIBLE. A LOOSE WHEEL SPINDLE MAY LEAD TO AN UNSTABLE DRIVING BEHAVIOR OF YOUR MOTORCYCLE.
- AFTER MOUNTING THE REAR WHEEL, KEEP OPERATING THE FOOTBRAKE UNTIL THE PRESSURE POINT RETURNS.
- IT IS VERY IMPORTANT TO KEEP THE BRAKE DISK FREE FROM OIL AND GREASE, OTHERWISE THE BRAKING EFFECT WOULD BE STRONGLY REDUCED.

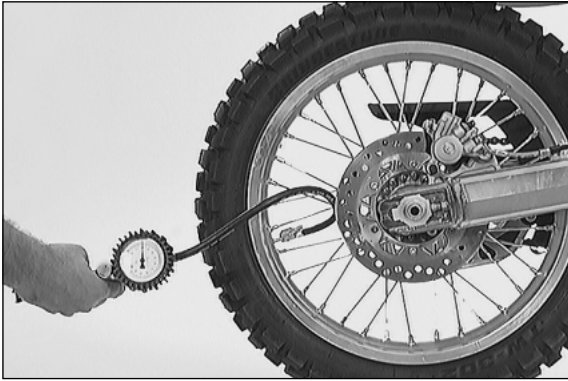

Tires, air pressure

Tire type, tire condition, and how much air pressure the tires have in them affect the way your motorcycle rides, and they must therefore be checked whenever you're getting ready to go anywhere on your motorcycle.

Tire type and size can be found in the technical specifications and in the homologation certificate

Tire condition has to be checked every time you want to ride your motorcycle. Before leaving check for punctures and nails or other sharp objects that might have become embedded in the tire.

Refer to the specific regulations in your country for minimum tire tread requirements. We recommend replacing tires at the latest when the tread is down to 2 mm.

Tire pressure should be checked regularly on a "cold" tire. Proper pressure ensures optimum driving comfort and extends the life of your tires.



WARNING



- DO NOT MOUNT TIRES WHICH HAVE NOT BEEN APPROVED BY KTM. OTHER TIRES COULD HAVE ADVERSE EFFECTS ON THE WAY YOUR MOTORCYCLE RIDES.
- THE FRONT AND REAR WHEEL ARE ONLY ALLOWED TO BE TIRED WITH TIRES THAT HAVE THE SAME PROFILE TYPE.
- FOR YOUR OWN SAFETY REPLACE DAMAGED TIRES IMMEDIATELY.
- WORN TIRES CAN HAVE A NEGATIVE EFFECT ON HOW YOUR MOTORCYCLE PERFORMS, ESPECIALLY ON WET SURFACES
- IF AIR PRESSURE IS TOO LOW, ABNORMAL WEAR AND OVERHEATING OF THE TIRE CAN RESULT

AIR-PRESSURE				
	125 EXE		125 Supermoto	
	front	rear	front	rear
Driver only	1,8 bar (26 psi)	2,0 bar (29 psi)	1,8 bar (26 psi)	2,1 bar (30 psi)
Driver plus passenger	2,0 bar (29 psi)	2,2 bar (32 psi)	2,0 bar (29 psi)	2,3 bar (33 psi)

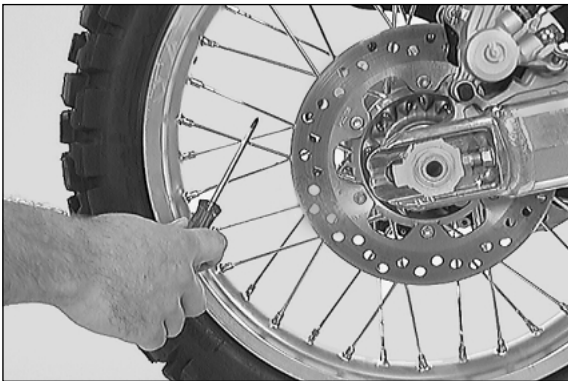

Checking spoke tension

The correct spoke tension is very important for the stability of the wheels and thus for riding safety. A loose spoke causes the wheel to become unbalanced and before long other spokes will have come loose. Check spoke tension, especially on a new motorcycle, in regular intervals. For checking, tap on each spoke with the blade of a screwdriver (see photo). A clear tone must be the result. Dull tones are indicators of loose spokes. If necessary, have the spokes retightened and the wheel centered by a KTM dealer.



WARNING



SPOKES CAN TEAR IF YOU CONTINUE TO RIDE WITH THEM LOOSE. THIS MAY LEAD TO AN UNSTABLE HANDLING OF YOUR MOTORCYCLE.

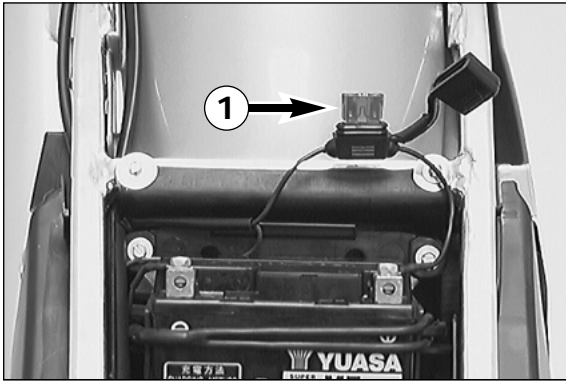

Main fuse

The main fuse ①, which is located above the carburetor, protects the following current consumers:

- Brake light
- Parking light
- Flasher lights
- Horn

Rated fuse current is 10 amperes

! CAUTION !

UNDER NO CIRCUMSTANCES IS A STRONGER FUSE ALLOWED TO BE SET IN OR A FUSE ALLOWED TO BE "REPAIRED". AN INEXPERT TREATMENT COULD DAMAGE THE WHOLE ELECTRICAL INSTALLATION!

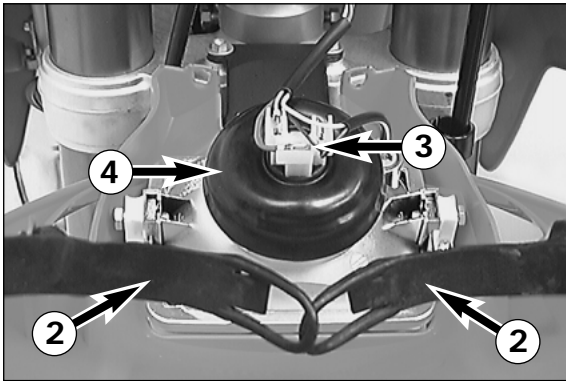

Replacing headlight lamp (H4)

Loosen both rubber bands ② and tilt headlight mask to the front. Remove bulb plug ③ and remove rubber cap ④. Turn the supporting ring counter-clockwise and remove it from the reflector together with the bulb.

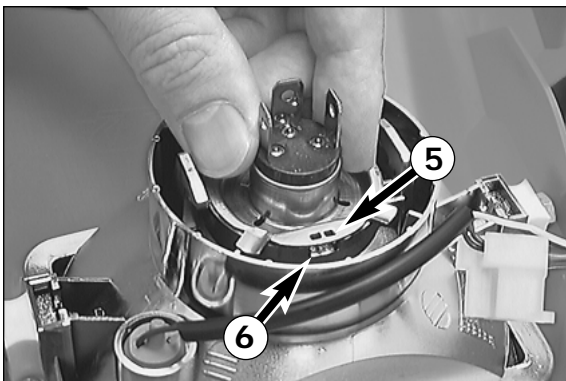

Insert a new bulb such that the noses ⑤ fit into the recess ⑥. Do not touch the glass body of the bulb, to keep it free from grease. Mount supporting ring, rubber cap and plug. Position headlight mask with the bottom holders, and fasten it with the rubber bands ②.

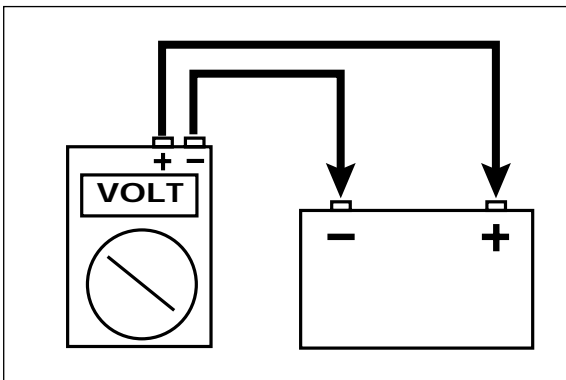

Charging the battery

Remove the battery (under the seat) and check the charging level. Use a voltmeter to measure the voltage between the battery poles (off-load voltage).

Accurate results can only be obtained if the battery has neither been charged nor discharged during a period of 30 minutes preceding the measuring.

off load voltage Volt	charging level %	charging time 0,3 A	charging voltage
>12,7	100	--	Max. 14,4 V
~12,5	75	4 h	
~12,2	50	7 h	
~12,0	25	11 h	
~11,8	0	14 h	

If the battery is empty, it can be recharged for a maximum period of 10 hours at 0.3 A and a maximum of 14.4 V.

! CAUTION !

- DO NOT REMOVE THE SEALING STRIP ⑦.
- ALWAYS CONNECT THE BATTERY TO THE CHARGING UNIT BEFORE TURNING THE CHARGING UNIT ON.
- WHEN RECHARGING THE BATTERY IN CLOSED ROOMS ENSURE SUFFICIENT VENTILATION. EXPLOSIVE GASES ARE RELEASED DURING THE BATTERY CHARGING PROCESS.
- CHARGING TIME AND CHARGING VOLTAGE SHOULD NOT EXCEED THE STATED VALUES. OTHERWISE ELECTROLYTE WILL BE RELEASED THROUGH THE SAFETY VALVES.
- AVOID QUICK CHARGING IF POSSIBLE.

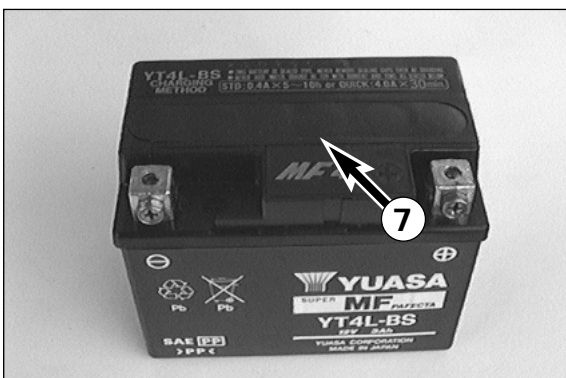

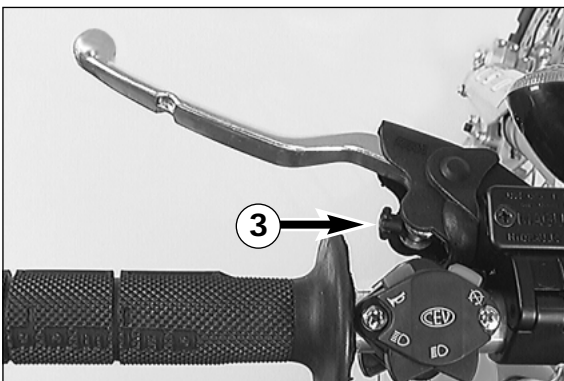
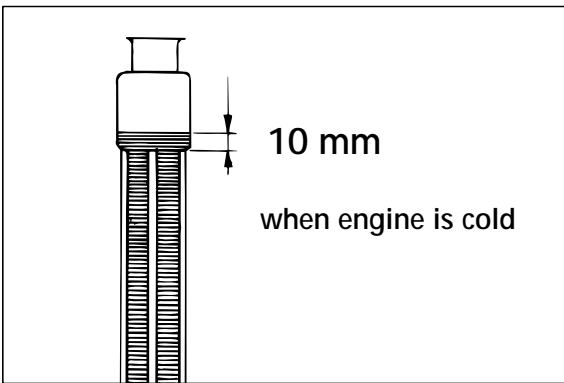
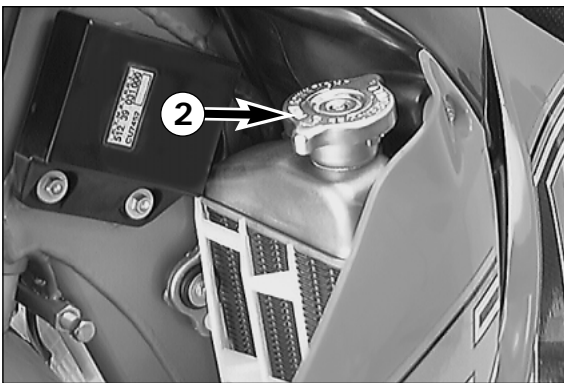
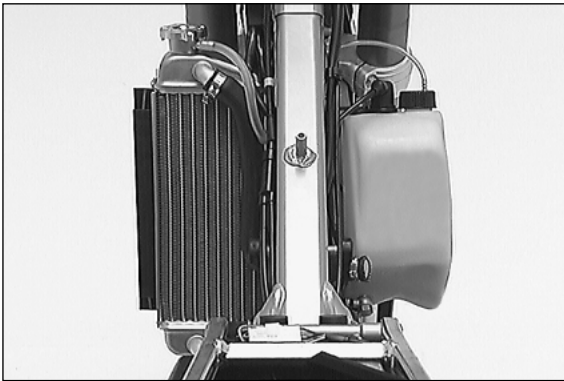
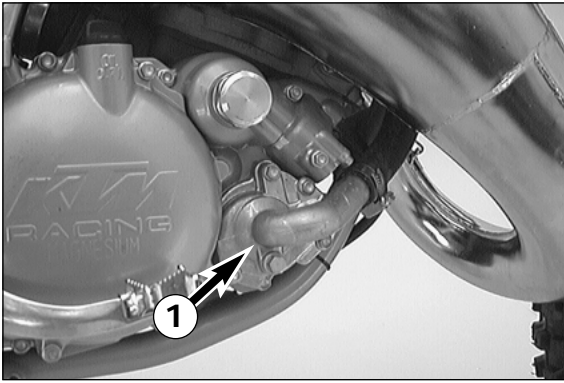

Cooling system

Coolant is circulated by a water pump ❶ located in the engine.

When the engine is cold, the cooling liquid circulates only through the cylinder and cylinder head. As soon as the cooling liquid has reached a temperature of approx. 65°C, the thermostat opens and the cooling liquid is pumped through the radiator.

Air blowing through the radiator cools the cooling liquid. Dirty radiator fins likewise reduce the cooling efficiency.



WARNING



- IF POSSIBLE, ALWAYS CHECK LEVEL OF COOLING LIQUID WHEN ENGINE IS COLD. IF YOU HAVE TO OPEN THE RADIATOR CAP ❷ WHEN THE ENGINE IS HOT, USE A RAG TO COVER THE CAP AND OPEN SLOWLY TO RELEASE PRESSURE. **CAUTION - SCALDING HAZARD !**
- DO NOT DETACH ANY RADIATOR HOSES WHILE THE ENGINE IS HOT. THE ESCAPING HOT COOLANT AND THE STEAM MAY CAUSE SERIOUS BURNS.
- IN CASE YOU GET BURNED, HOLD THE AFFECTED PART OF YOUR BODY UNDER RUNNING COLD WATER RIGHT AWAY!
- COOLANT IS TOXIC. KEEP THE COOLANT OUT OF THE REACH OF CHILDREN!
- IN CASE COOLANT IS INGESTED, GO SEE A DOCTOR IMMEDIATELY!
- IF COOLANT GETS INTO YOUR EYES, RINSE THEM OUT WITH WATER IMMEDIATELY AND GO SEE A DOCTOR!

A mixture of 40% anti freeze liquid and 60% water is used as coolant. However, the anti-freeze protection must be at least -25° C (-13° F). This mixture offers anti-freeze protection but also good corrosion protection and should therefore not be replaced by pure water.



CAUTION



FOR THE COOLING SYSTEM, USE ONLY WITH HIGH-GRADE ANTIFREEZE (I.E. SHELL ADVANCE COOLANT). USING LOWER-GRADE ANTIFREEZE AGENTS, CAN CAUSE CORROSION AND COOLANT FOAMING.

Pressure induced by heating of the coolant in the system is controlled by a valve in the radiator cap ❷; a water temperature of up to 120° C (248° F) is admissible therefore, having to expect any trouble.

Checking the coolant level

The coolant should be 10 mm (0.4 in) above the radiator fins when the engine is cold (cf. diagram). In the event of the coolant being drained, always fill and bleed the system.



WARNING



IF POSSIBLE, ALWAYS CHECK LEVEL OF COOLING LIQUID WHEN ENGINE IS COLD. IF YOU HAVE TO OPEN THE RADIATOR CAP WHEN THE ENGINE IS HOT, USE A RAG TO COVER THE CAP AND OPEN SLOWLY TO RELEASE PRESSURE.



CAUTION



THE COOLING SYSTEM MUST BE BLED AFTER DRAINING THE COOLING LIQUID OR AFTER ADDING MORE THAN 0.25 L (0.06 US GALLONS) COOLING LIQUID.

Changing the original position of the clutch lever

The adjusting screw ❸ can be used for individual adjustment of the original position of the clutch lever, thus allowing adjustment to an optimal position for every hand size.

Turning the adjusting screw clockwise reduces the distance between the clutch lever and the handlebar. Turning the adjusting screw counterclockwise increases the distance between the clutch lever and the handlebar.



CAUTION



ADJUSTMENT OF THE CLUTCH LEVER POSITION IS ONLY POSSIBLE WITHIN CERTAIN LIMITS. ONLY TURN THE ADJUSTING SCREW MANUALLY AND NEVER APPLY EXCESSIVE FORCE.

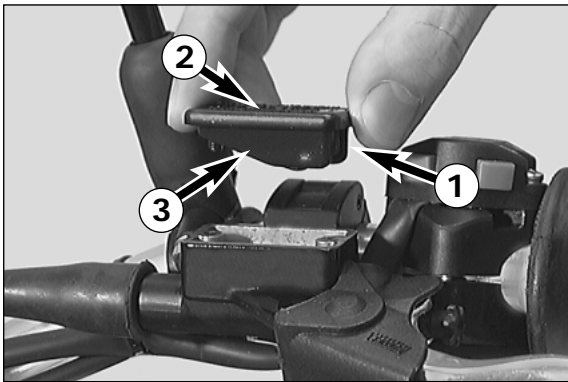

Checking the oil level of the hydraulic clutch

To check the oil level in the master cylinder of the clutch remove the cover. For this purpose, remove screws 1 and cover 2 together with the rubber boot 3. The oil level in the horizontal-standing master cylinder should be 4 mm below the upper edge. If necessary add SAE 10 hydraulic oil

! CAUTION !

ONLY USE SAE 10 MINERAL HYDRAULIC OIL (i.e. Shell Naturelle HF-E15) TO REFILL THE MASTER CYLINDER. NEVER USE BRAKE FLUID!

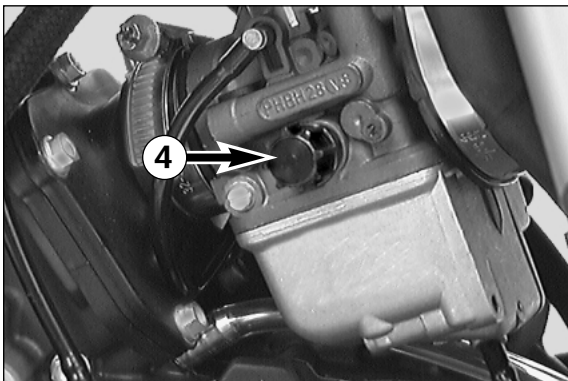

Adjusting the idle speed *

The idle speed can be adjusted with idle screw 4.

Turning in clockwise direction will increase the idle speed.
Turning in counter-clockwise direction will reduce the idle speed.

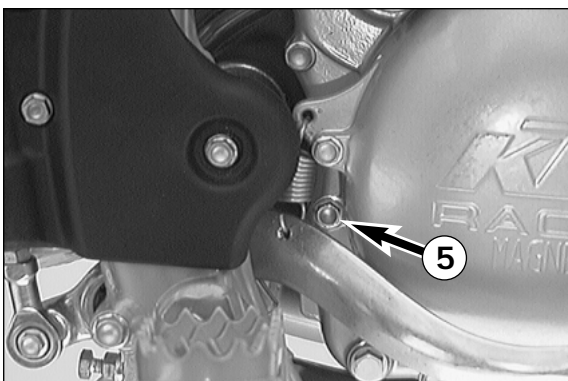

Check transmission oil level

In order to check the transmission oil level the control screw 5 on the clutch cover is to be removed. Oil should just barely escape from the inspection opening when the motorcycle is in an upright position. If necessary, remove the plug 6 and top up with gear oil SAE-80W (i. e. Shell Advance Gear EP).

! CAUTION !

TRANSMISSION AND CLUTCH WILL BE SUBJECT TO AXCESSIVE WEAR AND TEAR, IF YOU USE TOO LITTLE OR LOW GRADE OIL. USE ONLY HIGH-GRADE OIL (i. e. Shell Advance Gear EP).

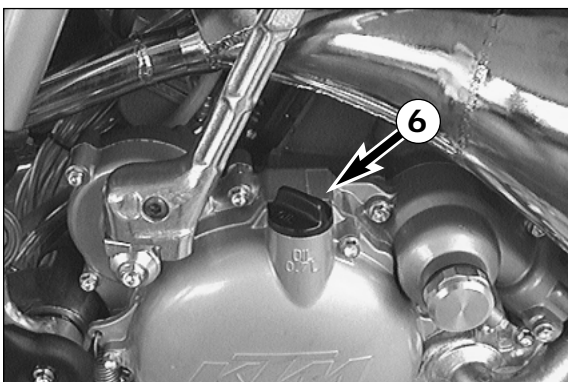

Changing the transmission oil *

To change the gear oil warm up the engine and park the motorcycle on a horizontal surface. Remove oil drain plugs 7 and 8 and drain the used oil into an appropriate container. Clean the magnets of the oil drain plugs and mount them together with the appropriate gaskets. Fill in 0.7 l gear oil SAE-80W (i. e. Shell Advance Gear EP), mount the plug 6 and check the engine for leaks.

! CAUTION !

TRANSMISSION AND CLUTCH WILL BE SUBJECT TO AXCESSIVE WEAR AND TEAR, IF YOU USE TOO LITTLE OR LOW GRADE OIL. USE ONLY HIGH-GRADE OIL (i. e. Shell Advance Gear EP).

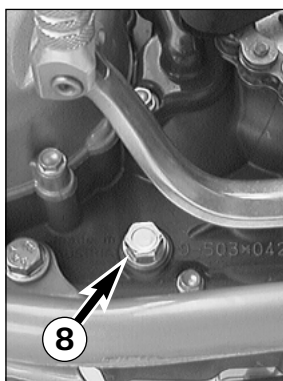
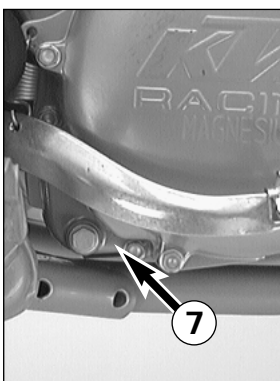

TROUBLE SHOOTING

If you let the specified maintenance work on your motorcycle be carried out, disturbances can hardly be expected. Should an error occur nevertheless, we advise you to use the trouble shooting chart in order to find the cause of error.

We would like to point out that many operations cannot be performed by oneself. In case of uncertainty, please contact a KTM-dealer.

TROUBLE	CAUSE	REMEDY
Engine will not start	Operating error	Switch on ignition, switch on emergency OFF switch, open fuel tap, tank fuel, do not use choke i.e. the hotstart device. Pay attention to starting off information (see driving instructions).
	Fuel supply interrupted	Close fuel tap, loosen fuel hose at carburettor, lead into a basin and open fuel tap, – if fuel leaks out, clean carburettor – if no fuel leaks out, check tank ventilation, i.e. clean fuel tap
	The motorcycle has been out of operation for a longer period of time. Therefore old fuel has accumulated in the float chamber	The easily inflammable components of the new fuels evaporate during longer periods of standstill. When the motorcycle has been out of operation for more than a week, it is therefore recommended to drain the old fuel from the float chamber. The engine will immediately start off when the float chamber is filled with new fuel.
	Flooded engine	Close the fuel tap and start the engine with full throttle. If the engine does not start, the spark plug needs cleaned. If the engine runs, the fuel tap is open too wide.
	Sooty or wet spark plug	Clean or replace spark plug
	Electrode gap too large	Adjust spark plug electrode gap to 0,6 mm
	Spark plug connector or spark plug faulty	Dismount spark plug, connect ignition cable, hold to ground (blank place on engine) and actuate kickstarter, a strong spark must be produced at the spark plug – If no spark is produced, loosen spark plug cap from ignition cable, hold about 5 mm from ground and actuate kickstarter – If a spark now occurs, replace spark plug cap – If no spark is produced, control ignition system
	If connector oxidates from generator to ignition coil	Remove fuel tank, clean connector and treat with contact spray
Engine will not idle	Water in carburettor or jets blocked	Dismount and clean carburettor
	Carburettor does not fit in properly at intake flange	Check if carburettor is fitted in correctly
	Idling jet blocked	Dismount carburettor and clean jets
Engine does not rev high	Adjusting screws on carburettor uncorrect adjusted	Adjust carburettor
	Ignition system faulty	Have ignition system checked
	Carburettor fuel level too high because float needle valve is dirty or worn out	Dismount carburettor and check if worn out
	Loose carburettor jets	Tighten jets
	Electronical ignition timing faulty	Have ignition system checked

TROUBLE	CAUSE	REMEDY
Engine will not reach full power	Fuel supply partially interrupted or carburettor dirty float is not tight Air filter very dirty Exhaust leaking or blocked Electronical ignition timing faulty	Clean and check fuel system as well as carburettor replace the float Clean or replace air filter Check if exhaust is damaged Have ignition system checked
Engine stops or splutters in carburettor	Insufficient fuel Engine takes air out of control	Clean and check fuel system and carburettor Check intake flange and carburettor if firmly setted
Engine gets to hot	Insufficient cooling liquid Not enough air stream Radiators very dirty Foam formation in cooling system Bent cooling hose Thermostat defective	Refill cooling liquid (see maintenace work), check cooling system for leaks Drive on briskly Clean radiators with water jet Replace cooling liquid, use anti freeze liquid with brand name Shorten or replace cooling hose Dismount and check thermostat (opening temperature 70°C, (158°F) or replace it
Parking light, indicators, brake lights and horn don't work	Main fuse has burnt through	Remove seat and replace main fuse.

CLEANING

Clean your motorcycle regularly in order to maintain the beauty of its plastic surfaces. The best manner would be to use warm water that has been mixed with a normal brand-name washing detergent and a sponge. The hard dirt can be removed before washing with the help of a soft water jet.

CAUTION

NEVER CLEAN YOUR MOTORCYCLE WITH A HIGH-PRESSURED CLEANER OR A HIGH-PRESSURED WATER JET. THE WATER COULD OTHERWISE RUN INTO THE ELECTRICAL COMPONENTS, CONNECTORS, SHEATHED CABLES, BEARINGS, CARBURETOR ETC. AND CAUSE DISTURBANCES OR LEAD TO A PREMATURE DESTRUCTION OF THESE PARTS.

- Befor cleaning with water, plug the exhaust pipe to prevent water ingress.
- You should use normal brand-name detergents to clean the motorcycle. Especially dirty parts should be cleaned additionally with the help of a paint brush.
- After the motorcycle has been rinsed with a soft water jet, it should be dried by air pressure and a cloth. Then take a short drive until the engine has reached the working temperature and also use the brakes. By warming these components, the residual water can evaporate from inaccessible parts of the engine and the brakes.
- Slide back the protective covers on the handlebar-mounted instruments so that any water that may have seeped into this part of the motorcycle is allowed to evaporate.
- After the motorcycle has cooled down, oil and grease all the gliding bearing parts. Treat the chain with a chain spray too.
- To prevent failures in the electric system, you should treat the ignition lock, the light switch and the socket connectors with contact spray.

CONSERVATION FOR WINTER OPERATION

In the event that the motorcycle is also used in winter and on roads where one has to expect salt spraying, you will have to take precautions against the aggressive road salt.

- clean motorcycle thoroughly and let it dry after each riding
- treat engine, carburetor, swing arm, and all other bare or galvanized parts (except for brake discs) with a wax-based anti-corrosion agent.

WARNING

KEEP ANTI-CORROSION AGENT FROM GETTING INTO CONTACT WITH THE BRAKE DISCS, FOR OTHERWISE THIS WILL SIGNIFICANTLY REDUCE THE BRAKING POWER.

CAUTION

AFTER RIDES ON SALTED ROADS, CLEAN MOTORCYCLE THOROUGHLY WITH COLD WATER AND LET IT DRY WELL!

STORAGE

Should you desire to make a pause over a longer space of time, please observe the following instructions:

- Clean motorcycle thoroughly (see chapter: CLEANING)
- Change gear oil (old gear oil contains aggressive contaminants).
- Check antifreezer and amount of cooling liquid.
- Let the engine warm up again, close fuel cock and wait until the engine dies off by itself. By this means, carburetor jets are prevented from becoming resinous by the old fuel.
- Remove spark plug and fill in approx. 5 ccm of engine oil into the cylinder through the opening. Actuate kick-starter 10 times in order to distribute the oil onto the cylinder walls and mount the spark plug.
- Let fuel flow out of tank into an appropriate container.
- Correct tire pressure.
- Lubricate bearing points of the control levers, foot rests, etc. as well as the chain.
- Disassemble and charge battery (see chapter Battery)
- The storage place should be dry and not be subject to too big temperature fluctuations.
- Cover the motorcycle with an air permeated tarp or blanket. Do not use non air permeable materials as a possible humidity might not be able to escape and thereby cause corrosion.

CAUTION

IT WOULD BE VERY BAD TO LET THE ENGINE RUN FOR A SHORT TIME DURING THE STORAGE PERIOD. THE ENGINE WOULD NOT GET WARMED UP ENOUGH AND THE THUS DEVELOPED STEAM WOULD CONDENSE DURING THE COMBUSTION PROCESS AND CAUSE THE VALVES AND EXHAUST TO RUST.

RE-INITIATION AFTER TIME OF STORAGE

- Mount the charged battery (regard polarity).
- Fill up tank with fresh fuel.
- Check motorcycle as before each start (see driving instructions)
- Take a short, careful test ride first.

NOTE: Before you put your motorcycle away for the winter, you have to check all parts for their function and wear. Should any service jobs, repairs, or any refitting be necessary, you should have them carried out during the off-season (lower workload at mechanics' shops). This way, you can avoid the long waiting times at your mechanic at the beginning of the next biking season.

TECHNICAL SPECIFICATIONS CHASSIS 125 EXE / 125 SUPERMOTO 2000

	125 EXE	125 Supermoto
Frame	Central chrome-moly-steel frame	
Fork	White Power – Up Side Down 40 TA	
Wheel travel front/rear	220/260 mm (8,7/10,2 in)	
Rear suspension	WP Progressive Damping System shock absorber, aluminium swingarm	
Front brake	Disc brake with carbon-steel brake disc, brake caliper floated	
Front brake disc	Ø 260 mm (10,2 in)	Ø 320 mm (12,6 in)
Rear brake	Disc brake with carbon-steel brake disc Ø 220 mm (8.7 in), brake caliper floated	
Brake discs	Wear limit max. 0,4 mm (0,016 in)	
Front tires	3.00 - 21"	110/70 - 17"
Air pressure, driver only	1,8 bar (26 psi)	1,8 bar (26 psi)
Air pressure, driver plus passenger	2,0 bar (29 psi)	2,0 bar (29 psi)
Rear tires	4.60 - 18"	130/70 - 17"
Air pressure, driver only	2,0 bar (29 psi)	2,1 bar (30 psi)
Air pressure, driver plus passenger	2,2 bar (32 psi)	2,3 bar (33 psi)
Fuel tank capacity	11,0 liter (3 US gallons), 2,5 liter (0,6 US gallons) reserve	
Final drive ratio	14:40 t	14:38 t
Chain	O-ring 5/8 x 1/4 "	
Battery	maintenance free 12V 3Ah	
Lamps	head light	H4 12V 60/55W (socket P43t)
	parking light	12V 5W (socket W2,1x9,5d)
	cockpit light	12V 2W (socket W2x4,6d)
	stop and tail light	12V 21/5W (socket BaY15d)
	flasher	12V 10W (socket Ba15s)
Steering head angle	63°	
Wheel base	1461 ± 10 mm (57,5 ± 0,4 in)	
Seat height, unloaded	865 mm (34,0 in)	830 mm (32,7 in)
Ground clearance, unloaded	290 mm (11,4 in)	255 mm (10,0 in)
Dead-weight *	104 kg (230 lbs)	
Max. permissible front axle load	145 kg (320 lbs)	
Max. permissible rear axle load	190 kg (419 lbs)	
Max. permissible laden weight	335 kg (740 lbs)	

* Dead-weight without fuel

STANDARD ADJUSTMENT - FORK

	WP 0618T777A
Compression adjuster	10
Rebound adjuster	9
Spring	4,2 N/mm
Spring preload	10 mm (0.4 in)
Air chamber length	140 mm (5.5 in)
Capacity per fork leg	approx. 500 ccm
Fork oil	SAE 5

STANDARD ADJUSTMENT - SHOCK ABSORBER

	WP 1218T715
Compression adjuster	3
Rebound adjuster	14
Spring	PDS1-250
Spring preload	5 mm (0.2 in)

TIGHTENING TORQUES - CHASSIS 125 EXE/SM

Collar nut front wheel spindle	M 16x1,5	40 Nm (30 ft.lb)
Brake caliper front	M 8	25 Nm (19 ft.lb) +Loctite 243
Clamping screws upper fork bridge	M 8	20 Nm (15 ft.lb)
Clamping screws lower fork bridge	M 8	15 Nm (11 ft.lb)
Clamping screws fork stubs	M8	10 Nm (7 ft.lb)
Collar nut rear wheel spindle	M 20x1.5	80 Nm (59 ft.lb)
Hexagon nut swing arm bolt	M 14x1.5	100 Nm (74 ft.lb)
Collar screw handlebar clamp	M 8	20 Nm (15 ft.lb)
Allen head screw handlebar support	M 10	40 Nm (30 ft.lb) +Loctite 243
Shock absorber top	M 12	60 Nm (44 ft.lb)
Shock absorber bottom	M 12	60 Nm (44 ft.lb)
Screw adjusting ring spring preload	M 6	8 Nm (6 ft.lb)
Other screws on chassis	M 6	10 Nm (7 ft.lb)
	M 8	25 Nm (19 ft.lb)
	M 10	45 Nm (33 ft.lb)

TECHNICAL DATA - ENGINE 125 EXE / 125 Supermoto 2000

Engine	125 EXE
Design	Liquid-cooled single-cylinder two-stroke engine with intake and exhaust control
Piston displacement	124.8 ccm
Bore / stroke	54,0 / 54,5 mm (2.125 / 2.145 in)
Fuel	unleaded fuel with a least RON 91
Lubrication	separate lubrication
Oil / gasolin ratio	Shell Advance Ultra 2 or 2-stroke oil for a mix ratio 1:50 and separate lubrication
Crankshaft bearing	2 grooved ball bearing
Connecting rod bearing	needle bearing
Piston pin bearing	needle bearing
Piston	cast light alloy
Piston ring	2 rectangular ring
Spark plug	NGK BR8 HS
Electrode gap	0.60 mm (0,024 in)
Primary drive	straight cut spur gears, primary ratio 23:73
Clutch	multiple disc clutch in oil bath, hydraulic operated (Shell HF-E15)
Transmission	6 speed, claw actuated
Gear ratio	
1st gear	12 : 33
2nd gear	15 : 31
3rd gear	17 : 28
4th gear	19 : 26
5th gear	21 : 25
6th gear	22 : 24
Gear lubrication	0.7 l gear oil SAE-80W (Shell Advance Gear EP)
Available chain sprockets	14t for chain $\frac{5}{8} \times \frac{1}{4}$ "
Coolant	0,8 litres, 40% anti freeze, 60% water, at least -25 °C (-13 °F)
Ignition system	Kokusan digital 2K-3
Generator output	12V / 110 W
Carburetor	flat-slide carburetor, carburetor setting see table
Air-filter	wet foam type air filter insert
Oil tank	tank content: 1,3 liter (0,34 US gallons)

BASIC CARBURETOR SETTING

	125 EXE (80 km/h)	125 EXE (100km/h)	125 Supermoto (80 km/h)	125 Supermoto (100 km/h)
Carburetor	Dell'Orto PHBH 28	Dell'Orto PHBH 28	Dell'Orto PHBH 28	Dell'Orto PHBH 28
Carburetor setting number	051299	021199	051299	021199
Main jet	120	125	120	125
Idling jet	50	50	50	50
Starting jet	70	70	70	70
Jetneedle	X83	X83	X83	X83
Needle position from top	III	III	III	III
Throttle valve	40	40	40	40
Air adjustment screw top	1,25	1,25	1,25	1,25
Performance restrictor	-	-	-	-

HEAD WORD INDEX

Page	Page		
Adjusting of free travel at the hand brake lever.....	19	Filler cap	6
Adjusting the idle speed.....	25	Flasher switch	5
Baggage carrier.....	8	Foot brake pedal.....	7
Breather plug front fork.....	16	Fuel	6
Center stand.....	8	Fuel tap	6
Chain maintenance.....	18	General informations about KTM disc brakes.....	18
Chain wear	18	Hand brake lever	4
Changing the basic position of the brake pedal.....	20	Head word index	31
Changing the original position of the clutch lever	25	How to change the handlebar position	15
Changing the spring preload of the shock absorber	16	Ignition lock.....	5
Changing the transmission oil	25	Kickstarter.....	7
Charging the battery.....	23	Main fuse	23
Chassis number.....	4	MAINTENANCE WORK ON CHASSIS AND ENGINE	14
Check chain tension.....	17	Oil tank	7
Check transmission oil level.....	25	OPERATION INSTRUMENTS	4
Checking and adjusting the steering head bearing	15	PERIODIC LUBRICATION- AND MAINTENANCE-SCHEDULE ...	13
Checking of brake fluid level - front brake	19	Pivot bearing	17
Checking rear brake fluid level.....	20	Rebound damping of fork.....	8
Checking spoke tension.....	22	Rebound damping of shock absorber.....	9
Checking the coolant level.....	24	Refilling the front brake fluid reservoir	19
Checking the front brake pads.....	19	Refilling the rear brake fluid reservoir.....	20
Checking the oil level of the hydraulic clutch	25	Replacing head light lamp (H4).....	23
Checking the rear brake pads.....	20	SERIAL NUMBER LOCATIONS	4
Choke.....	7	Shift lever	7
CLEANING.....	28	Speedometer, indicator lamps.....	5
Cleaning the dust sleeves of the telescopic fork	16	Steering lock.....	8
Clutch lever	4	STORAGE	28
Combination switch.....	5	TECHNICAL SPECIFICATIONS - CHASSIS	29
Compression damping of fork.....	8	TECHNICAL SPECIFICATIONS - ENGINE	30
Compression damping of shock absorber.....	9	Tires, air pressure.....	22
CONSERVATION FOR WINTER OPERATION	28	Trouble shooting.....	26
Cooling system	24	Use after period of storage	28
Correct chain tension.....	17	Wiring diagramme	Appendix
Dismounting and mounting of seat.....	14		
Dismounting and mounting the front wheel	21		
Dismounting and mounting the rear wheel.....	21		
DRIVING INSTRUCTIONS	10		
Engine number, engine type.....	4		



KTM SPORTMOTORCYCLE AG
5230 Mattighofen
Austria
Internet: www.ktm.at



ADVANCE
MOTORCYCLE OILS

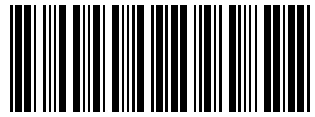

320596