

# OWNER'S MANUAL 2011

525 XC ATV EU

Art. no. 3211604en



**KTM**



# DEAR KTM CUSTOMER

Congratulations on your decision to buy a KTM ATV. You are now the owner of a state-of-the-art sports ATV that will give you enormous pleasure if you service and maintain it accordingly.

We wish you a lot of enjoyment in riding this vehicle!

Enter the serial numbers of your vehicle below.

Chassis number (☛ p. 16)	Dealer's stamp
Engine number (☛ p. 17)	
Key number (☛ p. 17)	

The owner's manual corresponded to the latest state of this series at the time of printing. Slight deviations resulting from continuing development and design can however not be completely excluded.

All specifications are not binding. KTM Sportmotorcycle AG specifically reserves the right to modify or delete technical specifications, prices, colors, forms, materials, services, designs, equipment, etc., without prior notice and without specifying reasons, to adapt these to local conditions, as well as to stop production of a particular model without prior notice. KTM accepts no liability for delivery options, deviations from illustrations and descriptions, as well as misprints and other errors. The models portrayed partly contain special equipment that does not belong to the regular scope of delivery.

© 2010 KTM-Sportmotorcycle AG, Mattighofen Austria

All rights reserved

Reproduction, even in part, as well as copying of all kinds, is permitted only with the express written permission of the copyright owner.



ISO 9001(12 100 6061)













According to the international quality management standard ISO 9001, KTM uses quality assurance processes that lead to the maximum possible quality of the products.















Issued by: TÜV Management Service





REG.NO. 12 100 6061

KTM-Sportmotorcycle AG  
5230 Mattighofen, Austria

MEANS OF REPRESENTATION .....	7	Setting kilometers or miles .....	28
IMPORTANT INFORMATION .....	8	Setting the clock .....	29
VIEW OF VEHICLE.....	12	Adjusting the speedometer functions.....	30
Vehicle view, front left .....	12	Querying the lap time .....	31
View of vehicle, rear right .....	14	Display mode SPEED (speed) .....	32
SERIAL NUMBERS.....	16	Display mode SPEED/H (service hours).....	33
Chassis number.....	16	Display mode SPEED/CLK (clock) .....	34
Type label.....	16	Display mode SPEED/LAP (lap time) .....	34
Engine number.....	17	Display mode SPEED/ODO (odometer).....	35
Key number .....	17	Display mode SPEED/TR1 (trip master 1) .....	35
Setting number, front shock absorber .....	18	Display mode SPEED/TR2 (trip master 2) .....	36
Setting number, rear shock absorber .....	18	Display mode SPEED/A1 (average speed 1).....	37
CONTROLS .....	19	Display mode SPEED/A2 (average speed 2).....	37
Clutch lever .....	19	Display mode SPEED/S1 (stop watch 1) .....	38
Hand brake lever, front parking brake .....	20	Display mode SPEED/S2 (stop watch 2) .....	39
Parking brake lever .....	21	Opening filler cap.....	41
Throttle lever.....	22	Closing filler cap .....	41
Kill switch .....	22	Fuel tap.....	42
Light switch .....	23	Choke.....	43
Turn signal switch .....	23	Hot start button.....	43
Horn button .....	24	Shift lever.....	44
Ignition switch .....	24	Foot brake lever.....	45
Electric starter button .....	25	Steering lock.....	45
Hazard warning flasher switch/hazard warning flasher .....	25	Locking the steering .....	46
Indicator lamp overview .....	26	Unlocking the steering .....	46
Emergency OFF switch with rip cord.....	26	PUTTING INTO OPERATION.....	47
Speedometer.....	27	Advice on first use.....	47
Speedometer activation and test .....	27	Running in the engine.....	49
Tripmaster switch.....	28		

RIDING INSTRUCTIONS .....	50	Rear shock absorber - adjusting the spring preload 	81
Checks and maintenance measures when preparing for use .....	50	Handlebar position .....	84
Starting .....	51	Adjusting the handlebar position 	85
Starting up .....	53	MAINTENANCE WORK ON THE CHASSIS .....	88
Shifting .....	54	Raising the vehicle with the lifting gear .....	88
Braking .....	54	Removing the vehicle from the lifting gear .....	88
Riding .....	55	Removing the rear shock absorber 	88
Riding in bends.....	56	Installing the rear shock absorber 	90
Riding downhill.....	57	Removing the radiator spoiler .....	90
Riding uphill.....	58	Installing the radiator spoiler .....	91
Riding perpendicular to the slope.....	59	Removing the front cover.....	93
Turning on slopes .....	59	Installing the front cover .....	93
Riding through water .....	61	Removing the rear fender .....	94
Switching off the engine .....	61	Installing the rear fender.....	95
Stopping, parking.....	63	Removing the seat.....	97
Refueling.....	64	Mounting the seat .....	97
SERVICE SCHEDULE.....	66	Removing the air filter 	98
Service schedule .....	66	Installing the air filter 	100
Maintenance work (as an additional order) .....	68	Cleaning the air filter and air filter box 	101
TUNING THE CHASSIS.....	70	Removing the fuel tank 	102
Basic information on changing the chassis settings.....	70	Installing the fuel tank 	103
Front shock absorber - adjusting the compression damping.....	70	Removing the front trim .....	104
Front shock absorber - adjusting the rebound damping.....	72	Installing the front trim .....	106
Front shock absorber - adjusting the spring preload .....	74	Checking the toe 	106
Front shock absorber - adjusting the cross over.....	76	Adjusting the toe 	109
Rear shock absorber - adjusting the compression damping ...	78	Checking/adjusting the camber 	111
Rear shock absorber - adjusting the rebound damping.....	80	Checking chain dirt .....	114
		Cleaning the chain.....	114

Checking the chain tension .....	115	WHEELS, TIRES .....	146
Adjusting chain tension.....	116	Removing wheel/wheels.....	146
Checking the chain, rear sprocket, engine sprocket, and chain guide.....	118	Mounting wheel/wheels .....	146
Greasing the rear wheel eccentric element .....	123	Checking the tire condition.....	147
Checking the throttle cable routing.....	123	Checking the tire air pressure .....	148
Adjusting basic position of clutch lever.....	124	ELECTRICAL SYSTEM .....	150
Checking fluid level of hydraulic clutch .....	124	Removing the battery .....	150
Removing the engine guard .....	125	Installing the battery.....	151
Installing the engine guard.....	125	Recharging the battery  .....	151
<b>BRAKES</b> .....	126	Changing the main fuse .....	153
Checking the free travel of the hand brake lever .....	126	Changing the fuses of individual power consumers.....	154
Adjusting basic position of hand brake lever.....	126	Checking the headlight setting.....	156
Checking brake discs .....	127	Adjusting the headlight range of the headlight.....	157
Checking front brake fluid level.....	128	COOLING SYSTEM .....	158
Topping up the front brake fluid  .....	129	Cooling system .....	158
Checking the front brake linings.....	131	Radiator fan.....	158
Changing the front brake linings  .....	132	Checking the antifreeze and coolant level .....	159
Removing front brake linings  .....	134	Checking the coolant level.....	160
Mounting front brake linings  .....	135	Draining coolant  .....	161
Checking free travel of foot brake lever .....	136	Filling coolant / bleeding cooling system  .....	163
Adjusting basic position of foot brake lever  .....	137	TUNING THE ENGINE .....	166
Checking rear brake fluid level.....	138	Checking the play in the throttle cable.....	166
Topping up brake fluid of rear brake  .....	139	Adjusting play in throttle cable .....	166
Checking rear brake linings .....	140	Carburetor - adjusting idle  .....	167
Changing rear brake linings  .....	141	Emptying the carburetor float chamber  .....	169
Removing rear brake linings  .....	142	Carburetor - idle .....	170
Mounting rear brake linings  .....	144	Checking the basic setting of the shift lever .....	171
		Adjusting the basic position of the shift lever  .....	171

MAINTENANCE WORK ON THE ENGINE.....	173	Option: KT 871.....	203
Checking the engine oil level .....	173	TECHNICAL DATA - CHASSIS TIGHTENING TORQUES .....	205
Changing engine oil and oil filter, cleaning oil screens  .....	174	SUBSTANCES.....	207
Draining engine oil, cleaning oil screens  .....	174	AUXILIARY SUBSTANCES.....	210
Removing the oil filter  .....	177	STANDARDS.....	213
Installing the oil filter  .....	179	INDEX .....	214
Filling up with engine oil  .....	179		
Adding engine oil .....	180		
CLEANING, CARE .....	182		
Cleaning the vehicle .....	182		
STORAGE .....	184		
Storage.....	184		
Putting the vehicle into operation after storage.....	185		
TROUBLESHOOTING.....	186		
TECHNICAL DATA - ENGINE .....	191		
Capacity - engine oil .....	192		
Capacity - coolant.....	192		
TECHNICAL DATA - ENGINE TIGHTENING TORQUES.....	193		
TECHNICAL DATA - CARBURETOR.....	196		
TECHNICAL DATA - CHASSIS .....	197		
Lighting equipment .....	199		
Tires .....	199		
Capacity - fuel.....	200		
TECHNICAL DATA - FRONT SHOCK ABSORBER.....	201		
Option: KT 770.....	201		
Option: KT 870.....	201		
TECHNICAL DATA - REAR SHOCK ABSORBER.....	203		
Option: KT 771.....	203		



## Symbols used

The symbols used are explained in the following.



Indicates an expected reaction (e.g. to a work step or a function).



Indicates an unexpected reaction (e.g. to a work step or a function).



All work marked with this symbol requires specialist knowledge and technical understanding. In the interest of your own safety, have these jobs performed at an authorized KTM workshop! There, your vehicle will be serviced optimally by specially trained experts using the specialist tools required.



Identifies a page reference (more information is provided on the specified page).

## Formats used

The typographical and other formats used are explained below.

**Specific name**

Identifies a proprietary name.

**Name<sup>®</sup>**

Identifies a protected name.

**Brand<sup>™</sup>**

Identifies a brand in merchandise traffic.

## Use definition

The vehicle is designed and constructed to withstand the usual demands of regular traffic and use on gentle terrain (unpaved roads), but not for use on race tracks.



### Info

The ATV is authorized for public road traffic in the homologous version only.

---

## Service

A prerequisite for perfect operation and prevention of wear is that the engine and chassis service, care and adjustment work described in the owner's manual are properly carried out. Poor adjustment and tuning of the engine and chassis can lead to damage and breakage of components.

Using the vehicle in difficult conditions such as very muddy or wet roads can lead to above-average wear of components such as the transmission train or the brakes. For this reason, it may be necessary to service or replace worn parts before the limit specified in the service schedule is reached.

Pay careful attention to the prescribed running-in period, inspection and service intervals. If you observe these exactly, you will ensure a much longer service life for your vehicle.

## Fuel, oils, etc.

You should use the fuels, oils and greases according to specifications as listed in the owner's manual.

## Spare parts, accessories

For your own safety, only use spare parts and accessories that have been approved and/or recommended by KTM and have them installed by an authorized KTM workshop. KTM accepts no liability for other products and any resulting damage or loss.

Certain spare parts and accessories are specified in parentheses in the descriptions. Your KTM dealer will be glad to advise you.

The current **KTM PowerParts** for your vehicle can be found on the KTM website.  
International KTM Website: <http://www.ktm.com>

## Work rules

Special tools are needed for certain tasks. They are not included with the vehicle but can be ordered under the number in parentheses.  
E.g.: valve spring mounter (59029019000)

During assembly, non-reusable parts (e.g. self-locking screws and nuts, seals, seal rings, O-rings, pins, lock washers) must be replaced by new parts.

Where thread lockers are used on screw connections (e.g., **Loctite**®), follow the instructions for use from the manufacturer.

Parts that are to be reused after disassembly must be cleaned and checked for damage and wear. Replace damaged or worn parts.  
After finishing the repair and maintenance work, ensure that the vehicle is roadworthy.

## Transport

### Note



**Danger of damage** Danger of damage from accidental rolling of vehicle.

- Park the vehicle on a surface that is as horizontal as possible and apply the parking brakes.

### Note

**Fire hazard** Some vehicle components become very hot when the vehicle is operated.

- Do not park the vehicle near flammable or explosive substances. Do not place objects on the vehicle while it is still warm from being run. Always let the vehicle cool first.

- 
- Switch off the engine.
  - Turn the handle ❶ of the fuel tap to **OFF**. (Figure 100013-10  p. 42)
  - Use straps or other suitable devices to secure the vehicle against accidents or falling over.
  - Fold down the parking brake lever ❶. (Figure 601044-10  p. 21)
  - Pull the hand brake lever, push the locking pawl ❷ down and release the hand brake lever. (Figure 302856-10  p. 20)

## Environment

ATV riding is a wonderful sport and we naturally hope that you will be able to enjoy it to the fullest. However, it is a potential problem for the environment and can lead to conflicts with other persons. If you use your ATV responsibly, you can ensure that such problems and conflicts do not have to occur. Make sure that you use your ATV legally, display environmental consciousness, and respect the rights of others.

## Rider training

If you have never ridden an ATV before, it is important that you participate in a driver training course before you ride the vehicle for the first time.

A professional trainer will show you how to handle your ATV safely in various riding situations and on different terrain. Your KTM dealer will be glad to advise you.

## Notes/warnings

Pay close attention to the notes/warnings.



### Info

Various information and warning labels are affixed to the vehicle. Do not remove information/warning labels. If they are missing, you or others may not recognize dangers and may therefore be injured.

## Grades of risks

---



### **Danger**

Identifies a danger that will immediately and invariably lead to fatal or serious permanent injury if the appropriate measures are not taken.



### **Warning**

Identifies a danger that is likely to lead to fatal or serious injury if the appropriate measures are not taken.



### **Caution**

Identifies a danger that may lead to minor injuries if the appropriate measures are not taken.

### **Note**

Identifies a danger that will lead to considerable machine and material damage if the appropriate measures are not taken.



### **Warning**

Identifies a danger that will lead to environmental damage if the appropriate measures are not taken.

---

## Owner's manual

- It is important that you read this owner's manual carefully and completely before making your first trip. It contains a lot of information and tips to help you operate and handle your vehicle. Only then will you find out how to customize the vehicle ideally for your own use and how you can protect yourself from injury. The owner's manual also contains important information on servicing the vehicle.
- The owner's manual is an important component of the vehicle and should be handed over to the new owner if the vehicle is sold.

Vehicle view, front left



---

1	Steering lock (☛ p. 45)
2	Setting number, front shock absorber (☛ p. 18)
3	Headlight
4	Fuse box
5	Hand brake lever, front parking brake (☛ p. 20)
6	Clutch lever (☛ p. 19)
7	Emergency OFF switch with rip cord (☛ p. 26)
8	Choke (☛ p. 43)
9	Hot start button (☛ p. 43)
10	Shift lever (☛ p. 44)

---

## View of vehicle, rear right





---

1	Rear brake
2	Rear shock absorber
3	License plate holder
4	Filler cap
5	Hazard warning flasher switch/hazard warning flasher (☛ p. 25)
6	Electric starter button (☛ p. 25)
7	Light switch, turn signal switch, kill switch, horn button
8	Parking brake lever (☛ p. 21)
9	Ignition switch (☛ p. 24)
10	Throttle lever (☛ p. 22)
11	Fuel tap (☛ p. 42)
12	Oil level viewer
13	Foot brake lever (☛ p. 45)

---

## Chassis number

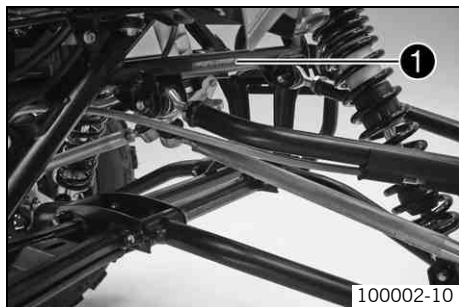

The chassis number ❶ is stamped on the right side of the frame in the vicinity of the upper control arm.

## Type label

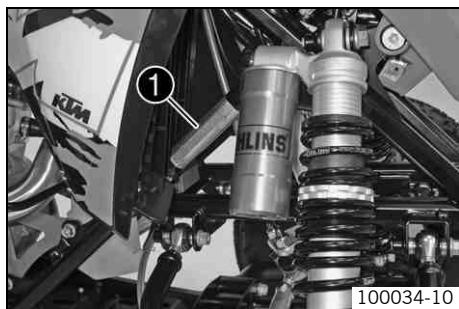

The type label ❶ is located on the frame tube on the right in front of the radiator.

## Engine number

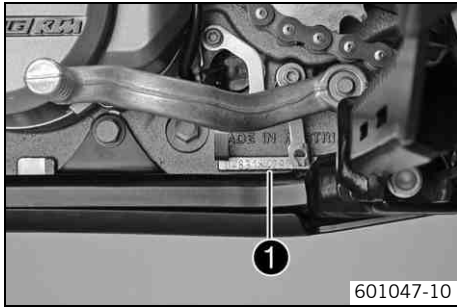

The engine number ❶ is stamped on the left side of the engine under the engine sprocket.

## Key number



The key number ❶ is indicated on the **KEYCODECARD**.



### Info

You need the key number to order a replacement key. Keep the **KEYCODECARD** in a safe place.

## Setting number, front shock absorber

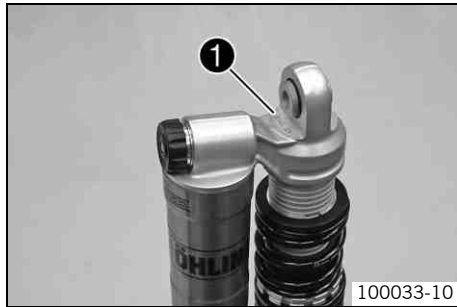

The setting number ❶ is stamped into the top of the shock absorber.

## Setting number, rear shock absorber

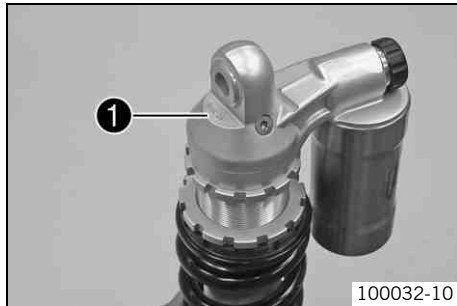

The setting number ❶ is stamped into the top of the shock absorber.

## Clutch lever

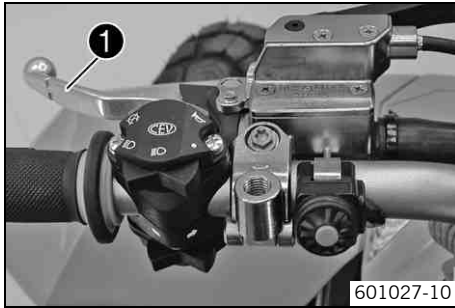

The clutch lever ❶ is fitted on the left side of the handlebar.

### Possible states

- Clutch lever in neutral position – In this position, the engine is force-locked with the gear and the starting circuit is interrupted. The electric starter does not turn over when the electric starter button is pressed.
- Clutch lever pulled – In this position, the force lock between the engine and the gear is broken and the starting circuit is closed. The electric starter turns over when the electric starter button is pressed.

The clutch is hydraulically operated and self-adjusting.

## Hand brake lever, front parking brake

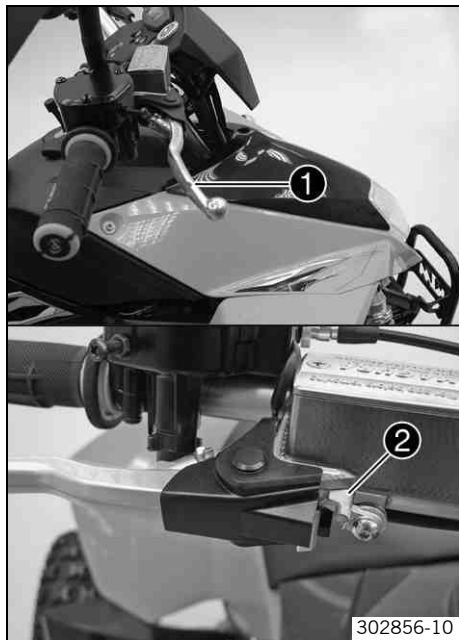

The hand brake lever ❶ is located on the right side of the handlebar and operates the front brakes.

The hand brake lever is combined with the front parking brake, which locks the front wheels to prevent the vehicle from rolling away.

To apply the parking brake, pull the hand brake lever, push the locking pawl ❷ down and release the hand brake lever.

### Possible states

- Hand brake lever in basic position – The front wheels are not locked.
- Hand brake lever pulled and locked in position – The front wheels are locked.

## Parking brake lever

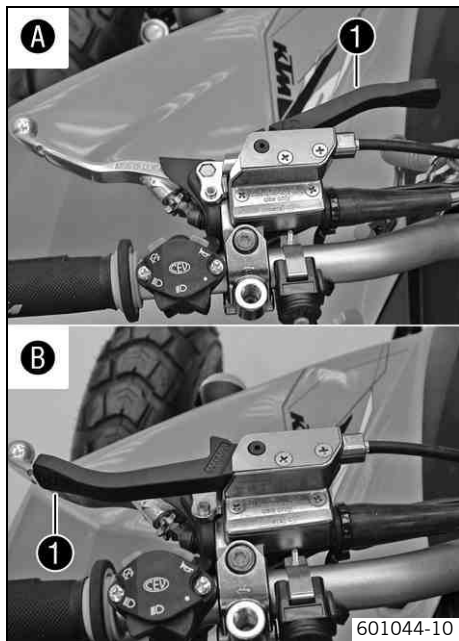

The parking brake lever ❶ is located on the left side of the handlebar and operates the rear brakes.

The parking brake lever is combined with the parking brake, which locks the rear wheels to prevent the vehicle from rolling away.

To apply the parking brake, fold down the parking brake lever.

### Possible states

- A Parking brake lever ❶ in basic position – The rear wheels are not locked.
- B Parking brake lever ❶ pulled – The rear wheels are locked.

## Throttle lever

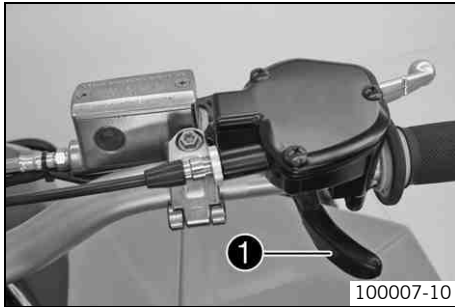

The throttle lever ❶ is fitted on the right side of the handlebar.  
The throttle lever is used to control the engine speed.

## Kill switch

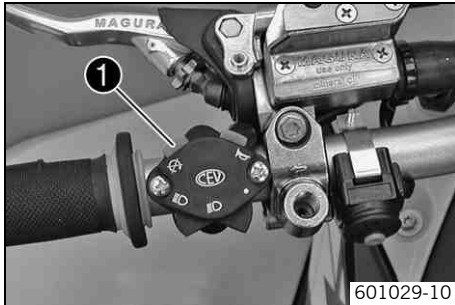

The kill switch ❶ is fitted on the left side of the handlebar.

### Possible states

- Kill switch ☒ in basic position – In this position, the ignition circuit is closed and the engine can be started.
- Kill switch ☒ pressed – In this position, the ignition circuit is interrupted, a running engine stops, and a non-running engine will not start.



## Light switch

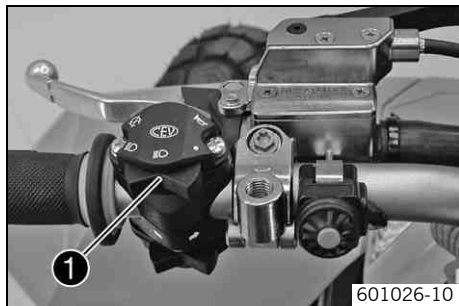

601026-10

The light switch ❶ is fitted on the left side of the handlebar.

### Possible states

●	Lights off – The light switch is rocked to the right. In this position, the light is switched off.
☰☷	Low beam on – Light switch in the middle position. In this position, the low beam and tail lights are switched on.
☰☷	High beam on – The light switch is rocked to the left. In this position, the high beam and the tail light are switched on.

## Turn signal switch



601028-10

The turn signal switch ❶ is fitted on the left side of the handlebar.

### Possible states

	Turn signal off – The turn signal switch is in the central position.
←	Left turn signal on – The turn signal switch is rocked to the left.
→	Right turn signal on – The turn signal switch is rocked to the right.



## Horn button



601030-10

The horn button ❶ is fitted on the left side of the handlebar.

### Possible states

- Horn button  in basic position
- Horn button  pressed – In this position, the horn is actuated.



## Ignition switch



601032-10

The ignition switch ❶ is located to the right of the speedometer.

### Possible states

	<p>Ignition off – In this position, the ignition circuit is interrupted, a running engine stops, and a non-running engine will not start.</p>
	<p>Ignition on – In this position, the ignition circuit is closed and the engine can be started.</p>

## Electric starter button



The electric starter button ❶ is fitted on the left side of the handlebar.

### Possible states

- Electric starter button in basic position
- Electric starter button pressed – In this position, the electric starter is actuated.

## Hazard warning flasher switch/hazard warning flasher



The hazard warning flasher switch ❶ is fitted centrally below the indicator lamps. The hazard warning flasher is used to indicate emergency situations.



### Info

The hazard warning flasher can be activated or deactivated while the ignition is switched on or up to 30 seconds after it is switched off.

Only activate the hazard warning flasher as long as absolutely necessary to avoid discharging the battery.

### Possible states

	Hazard warning flasher off
	Hazard warning flasher on – All four turn signals, the hazard warning flasher switch and the green turn signal indicator light flash.

## Indicator lamp overview

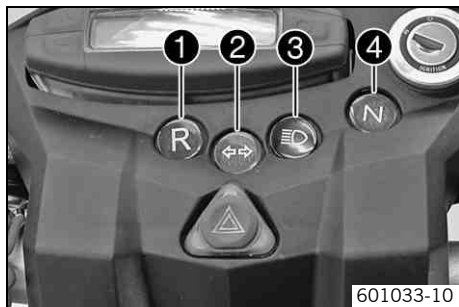

601033-10

### Possible states

	Reverse gear indicator lamp ❶ – No function.
	Turn signal indicator light ❷ flashes green with the flashing rhythm – The turn signal is switched on.
	High beam indicator lamp ❸ lights up blue – The high beam is switched on.
	Idling speed indicator lamp ❹ lights up green – The transmission is switched to idle.

## Emergency OFF switch with rip cord

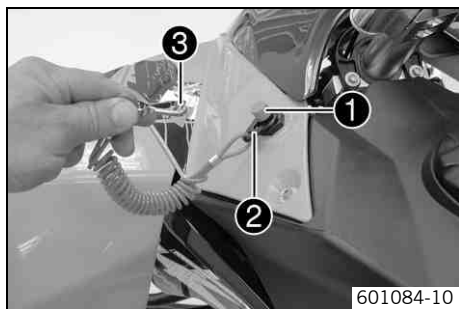

601084-10



The emergency OFF switch ❶ is mounted on the left in front of the fuel tank. The emergency OFF switch shuts the engine off if the rider falls off the vehicle. Clip ❷ is attached to a rip cord that can be attached to the clothing of the rider by means of a carabiner ❸.

### Possible states

- Clip is pulled off – The ignition circuit is interrupted, a running engine stops and a non-running engine will not start.
- Clip is mounted – The ignition circuit is closed and the engine can be started.

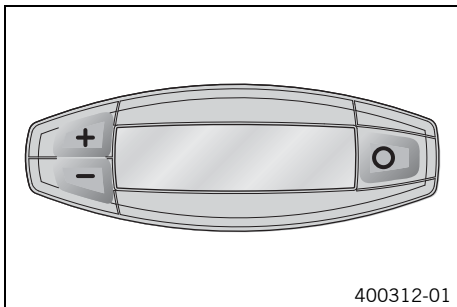
## Speedometer



- Press the key  to change the display mode or change to one of the Setup menus.
- Press the key  to control different functions.
- Press the key  to control different functions.



### Info

When the vehicle is delivered, only the **SPEED/H** and **SPEED/ODO** display modes are activated.

## Speedometer activation and test

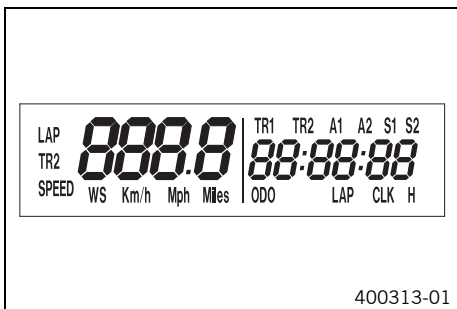

To activate the speedometer:

The speedometer is activated when one of the buttons is activated or a pulse arrives from the wheel speed sensor.

Display test

To test the display function, all display segments light up briefly.

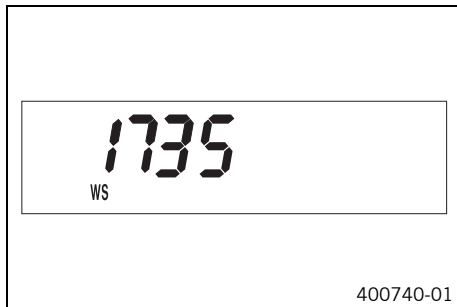

## **WS** (wheel size)

After the display function test, the wheel size **WS** is displayed briefly.



### **Info**

1735 mm corresponds to a circumference of 10" for the front wheels with series tires.

After this, the display changes to the mode selected last.

## **Tripmaster switch**

You can use the trip master switch to control the functions of the speedometer from the handlebar.



### **Info**

The trip master is an optional accessory.

## **Setting kilometers or miles**







### **Info**

If you change the unit of measure, the **ODO** value is retained and converted accordingly. The values **TR1**, **TR2**, **A1**, **A2** and **S1** are cleared when the unit of measure is changed.

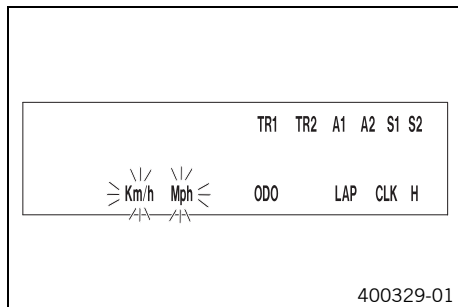
### **Condition**

The vehicle is stationary.





- Press the button  briefly and repeatedly until **H** appears at the bottom right of the display.
- Press the button  for 3 - 5 seconds.
  - ✓ The Setup menu is displayed and the active functions are shown.
- Press the button  repeatedly until the **Km/h/Mph** display flashes.

### Adjusting Km/h

- Press the button .

### Adjusting Mph

- Press the button .
- Press the button  for 3 - 5 seconds.

- ✓ The settings are stored and the Setup menu is closed.

---

### Info

If no button is pressed for 20 seconds, or if no impulse comes from the wheel speed sensor, the settings are automatically saved and the Setup menu is closed.





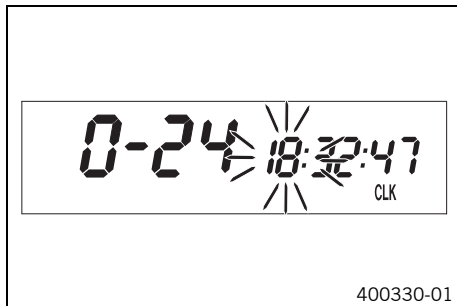

---

## Setting the clock

### Condition

The vehicle is stationary.



- Press the button  briefly and repeatedly until **CLK** appears at the bottom right of the display.
- Press the button  for 3 - 5 seconds.
  - ✓ The hour display flashes.
- Set the hour display with the button  and/or button .
- Press the button  briefly.
  - ✓ The next segment of the display flashes and can be set.
- You can set the following segments in the same way as the hours by pressing the button  and the button .

 **Info**

The seconds can only be set to zero.

- Press the button  for 3 - 5 seconds.
  - ✓ The settings are stored and the Setup menu is closed.

 **Info**

If no button is pressed for 20 seconds, or if a pulse arrives from the wheel speed sensor, the settings are stored automatically and the Setup menu is closed.

## Adjusting the speedometer functions

 **Info**



When the vehicle is delivered, only the **SPEED/H** and **SPEED/ODO** display modes are activated.

**Condition**

The vehicle is stationary.

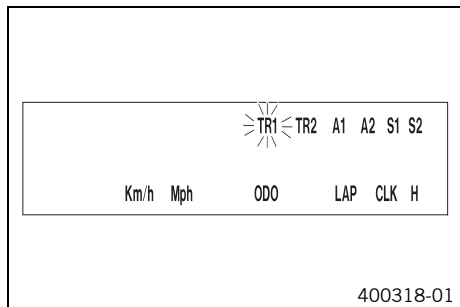





- Press the button  briefly and repeatedly until **H** appears at the bottom right of the display.
- Press the button  for 3 - 5 seconds.
  - ✓ The Setup menu is displayed and the activated functions are shown.
- Change to the desired function by pressing the button  briefly.
  - ✓ The selected function flashes.

### Activating a function

- Press the button .
  - ✓ The symbol remains on the screen and the display changes to the next function.

### Deactivating the function

- Press the button .
  - ✓ The symbol on the screen goes out and the display changes to the next function.
- All desired functions are activated or deactivated accordingly.
- Press the button  for 3 - 5 seconds.
  - ✓ The settings are stored and the Setup menu is closed.

### Info

If no button is pressed for 20 seconds, or if a pulse arrives from the wheel speed sensor, the settings are stored automatically and the Setup menu is closed.





## Querying the lap time

### Info

This function can be called only if lap times are measured.

## Condition

The vehicle is stationary.

- Press the button  briefly and repeatedly until **LAP** appears at the bottom right of the display.
- Press the button  briefly.
- ✓ **LAP 1** appears on the left side of the display.
- Laps 1-10 can be displayed by pressing the button .
- The  button has no function
- Press the button  briefly.
- ✓ Next display mode

## Info

If an impulse is received from the wheel speed sensor, the left side of the display changes back to the **SPEED** mode.

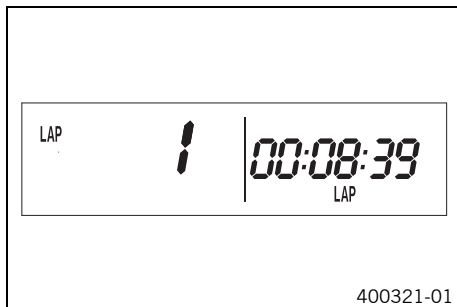

## Display mode SPEED (speed)

- Press the button  briefly and repeatedly until **SPEED** appears on the left side of the display.

The current speed is displayed in the **SPEED** display mode.

The current speed can be displayed in **Km/h** or **Mph**.

## Info

Making the setting according to the country.

When an impulse comes from the front wheel, the left side of the speedometer display changes to the **SPEED** mode and the current speed is shown.

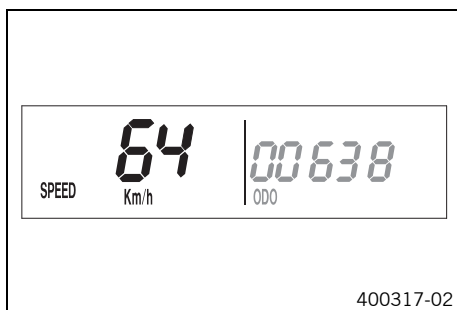

## Display mode SPEED/H (service hours)



### Condition

- The vehicle is stationary.
- Press the button  briefly and repeatedly until **H** appears at the bottom right of the display.





In display mode **H**, the service hours of the engine are displayed. The service hour counter stores the total traveling time.

### Info

The service hour counter is necessary for ensuring that maintenance work is carried out at the right intervals.

If the speedometer is in **H** display mode at the start of the journey, it automatically changes to the **ODO** display mode.

The **H** display mode is suppressed during the journey.

Press the button  .	No function
Press the button  .	No function
Press the button  for 3 - 5 seconds.	The display changes to the Setup menu of the speedometer functions.
Press the button  briefly.	Next display mode

## Display mode SPEED/CLK (clock)

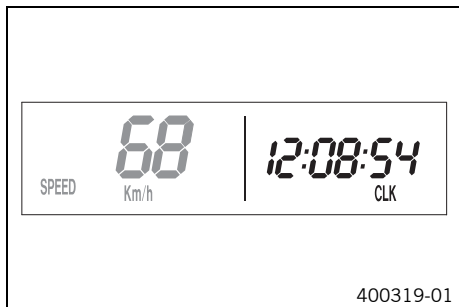

- Press the button briefly and repeatedly until **CLK** appears at the bottom right of the display.

The time is displayed in **CLK** display mode.

Press the button .	No function
Press the button .	No function
Press the button  for 3 - 5 seconds.	The display changes to the Setup menu of the clock.
Press the button  briefly.	Next display mode

## Display mode SPEED/LAP (lap time)

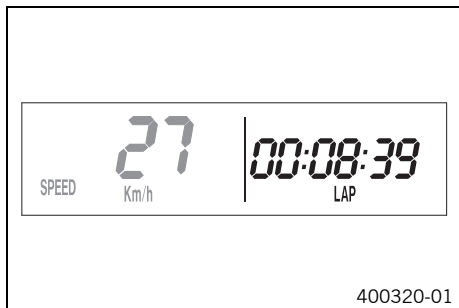

- Press the button briefly and repeatedly until **LAP** appears at the bottom right of the display.

In the **LAP** display mode, up to 10 lap times can be timed with the stop watch.

---

**Info**  
 If the lap time continues after you press the button , 9 memory locations are already occupied.  
 Lap 10 must be timed with the button .

---

Press the button .	Starts or stops the clock.
Press the button .	Stops the current lap time and saves it, and the stop watch starts the next lap.
Press the button  for 3 - 5 seconds.	The stop watch and the lap time are reset.



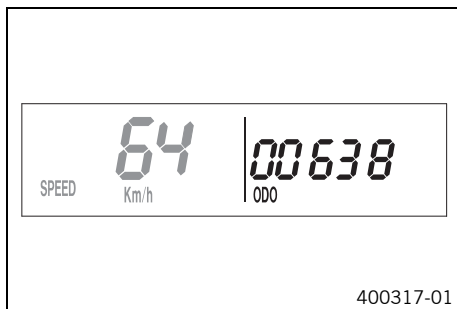

Press the button  briefly.	Next display mode
---	-------------------

## Display mode SPEED/ODO (odometer)





- Press the button  briefly and repeatedly until **ODO** appears at the bottom right of the display.

The total distance traveled is displayed in the **ODO** display mode.

Press the button  .	No function
Press the button  .	No function
Press the button  for 3 - 5 seconds.	–
Press the button  briefly.	Next display mode

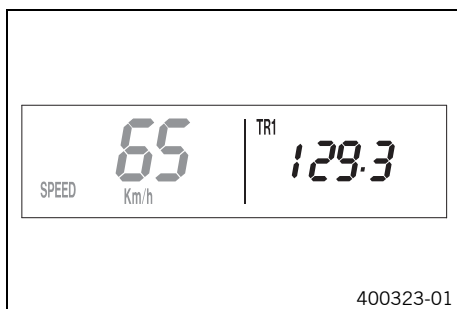
## Display mode SPEED/TR1 (trip master 1)



- Press the button  briefly and repeatedly until **TR1** appears at the top right of the display.

**TR1** (trip master 1) runs constantly and counts to 999.9.



You can use it to measure trips or the distance between refueling stops.



**TR1** is coupled with **A1** (average speed 1) and **S1** (stop watch 1).



### Info

If 999.9 is exceeded, the values of **TR1**, **A1** and **S1** are automatically reset to 0.0.

Press the button  .	No function
Press the button  .	No function

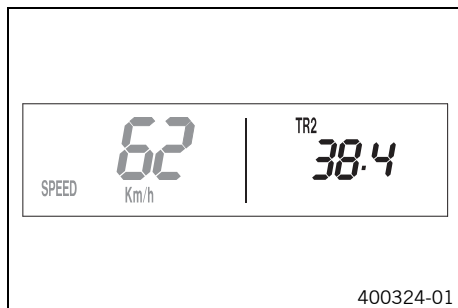

Press the button  for 3 - 5 seconds.	The <b>TR1</b> , <b>A1</b> and <b>S1</b> displays are reset to 0.0.
Press the button  briefly.	Next display mode

## Display mode SPEED/TR2 (trip master 2)





- Press the button  briefly and repeatedly until **TR2** appears at the top right of the display.

**TR2** (trip master 2) runs constantly and counts up to 999.9.





The displayed value can be set manually with the button  and the button . This is a very practical function when riding using the road book.



### Info

The **TR2** value can also be corrected manually during the journey with the button  and the button .

If 999.9 is exceeded, the value of **TR2** is automatically reset to 0.0.

Press the button  .	Increases value of <b>TR2</b> .
Press the button  .	Reduces value of <b>TR2</b> .
Press the button  for 3 - 5 seconds.	Deletes value of <b>TR2</b> .
Press the button  briefly.	Next display mode



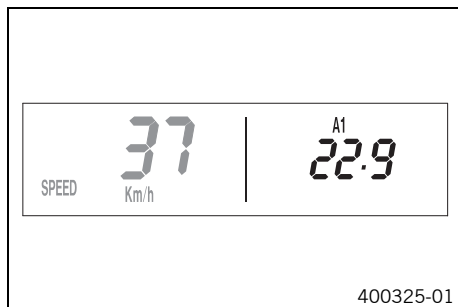

## Display mode SPEED/A1 (average speed 1)



- Press the button  briefly and repeatedly until **A1** appears at the top right of the display.

**A1** (average speed 1) shows the average speed calculated on the basis of **TR1** (trip master 1) and **S1** (stop watch 1).

The calculation of this value is activated by the first impulse of the wheel speed sensor and ends 3 seconds after the last impulse.

Press the button  .	No function
Press the button  .	No function
Press the button  for 3 - 5 seconds.	The <b>TR1</b> , <b>A1</b> and <b>S1</b> displays are reset to 0.0.
Press the button  briefly.	Next display mode



## Display mode SPEED/A2 (average speed 2)





- Press the button  briefly and repeatedly until **A2** appears at the top right of the display.

**A2** (average speed 2) shows the average speed on the basis of the current speed if the stop watch **S2** (stop watch 2) is running.

 **Info**  
The displayed value can differ from the actual average speed if **S2** was not timed after the ride.

Press the button  .	No function
Press the button  .	No function

Press the button  for 3 - 5 seconds.	–
Press the button  briefly.	Next display mode





## Display mode SPEED/S1 (stop watch 1)



- Press the button  briefly and repeatedly until **S1** appears at the top right of the display.

**S1** (stop watch 1) displays the journey time on the basis of **TR1** and continues when an impulse is received from the wheel speed sensor.

The calculation of this value starts with the first impulse of the wheel speed sensor and ends 3 seconds after the last impulse.

Press the button  .	No function
Press the button  .	No function
Press the button  for 3 - 5 seconds.	Displays of <b>TR1</b> , <b>A1</b> and <b>S1</b> are reset to 0.0.
Press the button  briefly.	Next display mode







## Display mode SPEED/S2 (stop watch 2)



– Press the button  briefly and repeatedly until **S2** appears at the top right of the display.

**S2** (stop watch 2) is a manual stop watch.

If **S2** is running in the background, the **S2** display flashes in the speedometer display.

Press the button  .	Starts or stops <b>S2</b> .
Press the button  .	No function
Press the button  for 3 - 5 seconds.	Displays of <b>S2</b> and <b>A2</b> are reset to 0.0.
Press the button  briefly.	Next display mode

### Table of functions





Display	Press the button  .	Press the button  .	Press the button  for 3 - 5 seconds.	Press the button  briefly.
Display mode <b>SPEED/H</b> (service hours)	No function	No function	The display changes to the Setup menu of the speedometer functions.	Next display mode
Display mode <b>SPEED/CLK</b> (clock)	No function	No function	The display changes to the Setup menu of the clock.	Next display mode
Display mode <b>SPEED/LAP</b> (lap time)	Starts or stops the clock.	Stops the current lap time and saves it, and the stop watch starts the next lap.	The stop watch and the lap time are reset.	Next display mode
Display mode <b>SPEED/ODO</b> (odometer)	No function	No function	–	Next display mode

Table of functions				
Display	Press the button <b>+</b> .	Press the button <b>-</b> .	Press the button <b>○</b> for 3 - 5 seconds.	Press the button <b>○</b> briefly.
Display mode <b>SPEED/TR1</b> (trip master 1)	No function	No function	The <b>TR1</b> , <b>A1</b> and <b>S1</b> displays are reset to 0.0.	Next display mode
Display mode <b>SPEED/TR2</b> (trip master 2)	Increases value of <b>TR2</b> .	Reduces value of <b>TR2</b> .	Deletes value of <b>TR2</b> .	Next display mode
Display mode <b>SPEED/A1</b> (average speed 1)	No function	No function	The <b>TR1</b> , <b>A1</b> and <b>S1</b> displays are reset to 0.0.	Next display mode
Display mode <b>SPEED/A2</b> (average speed 2)	No function	No function	–	Next display mode
Display mode <b>SPEED/S1</b> (stop watch 1)	No function	No function	Displays of <b>TR1</b> , <b>A1</b> and <b>S1</b> are reset to 0.0.	Next display mode
Display mode <b>SPEED/S2</b> (stop watch 2)	Starts or stops <b>S2</b> .	No function	Displays of <b>S2</b> and <b>A2</b> are reset to 0.0.	Next display mode

Table of conditions and menu activation		
Display	The vehicle is stationary.	Menu can be activated
Display mode <b>SPEED/H</b> (service hours)	•	
Display mode <b>SPEED/CLK</b> (clock)		•
Display mode <b>SPEED/LAP</b> (lap time)		•
Display mode <b>SPEED/TR1</b> (trip master 1)		•
Display mode <b>SPEED/TR2</b> (trip master 2)		•
Display mode <b>SPEED/A1</b> (average speed 1)		•
Display mode <b>SPEED/A2</b> (average speed 2)		•
Display mode <b>SPEED/S1</b> (stop watch 1)		•

Table of conditions and menu activation		
Display	The vehicle is stationary.	Menu can be activated
Display mode <b>SPEED/S2</b> (stop watch 2)		•

## Opening filler cap

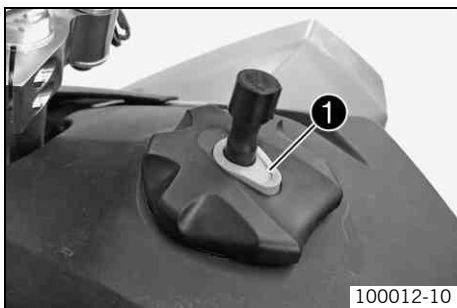

- Press release button ❶, turn filler cap counterclockwise and lift it free.

## Closing filler cap

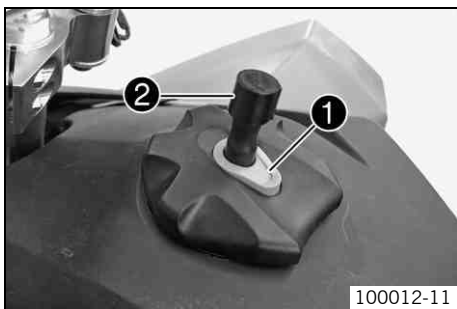

- Replace the filler cap and turn clockwise until the release button ❶ locks in place.
- Check the fuel tank breather ❷ to ensure it is properly seated.
  - » If the fuel tank breather is at an angle or loose:
    - Correctly mount the fuel tank breather.

## Fuel tap



The fuel tap is on the right of the fuel tank.

With the tap handle ❶ on the fuel tap, you can open or close the supply of fuel to the carburetor.

### Possible states

- Fuel supply off **OFF** – No fuel can flow from the tank to the carburetor.
- Fuel supply on **ON** – Fuel can flow from the tank to the carburetor. The fuel tank empties down to the reserve.
- Reserve fuel supply on **RES** – Fuel can flow from the tank to the carburetor. The fuel tank empties completely.

**OFF**



**ON**



**RES**



100013-10

## Choke

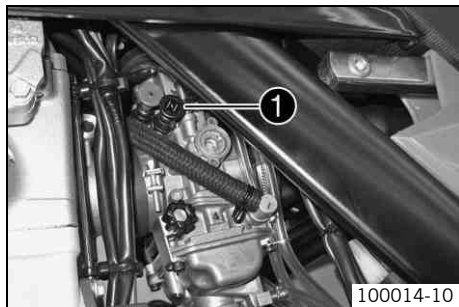

The choke ❶ is fitted on the left side of the carburetor. Activating the choke function frees an opening through which the engine can draw extra fuel. This gives a richer fuel-air mixture, which is needed for a cold start.



### Info

If the engine is warm, the choke function must be deactivated.

### Possible states

- Choke function activated – The choke lever is pulled out to the stop.
- Choke function deactivated – The choke lever is pushed in to the stop.

## Hot start button

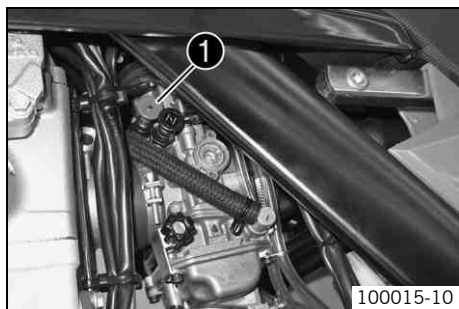

The hot start button (red) ❶ is fitted on the left side of the carburetor. Activating the hot start function frees an opening in the carburetor through which the engine can draw extra air. This gives a leaner fuel-air mixture, which is needed for a hot start.



### Info

If the engine is cold, the hot start function must be deactivated.

### Possible states

- Hot start function activated – The hot start button is pulled out to the stop.
- Hot start function deactivated – The hot start button is pushed in as far as possible.

## Shift lever

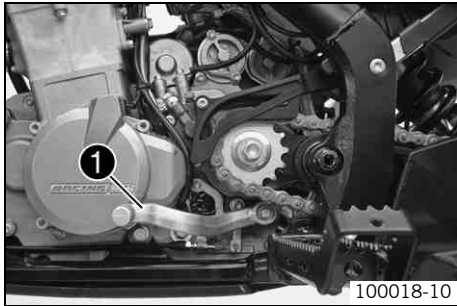

The shift lever ❶ is mounted on the left side of the engine.

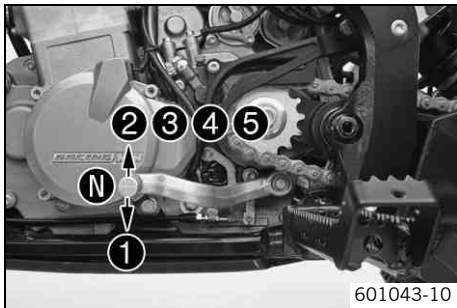

The gear positions can be seen in the photograph.  
The neutral or idle position is between the first and second gears.

## Foot brake lever

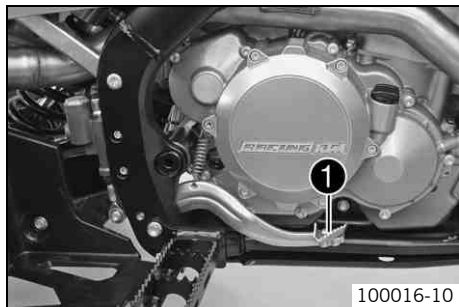

The foot brake lever ❶ is located in front of the right footrest.  
The foot brake lever activates the brakes of all four wheels.

## Steering lock

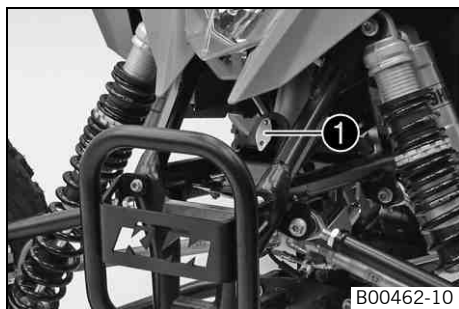

The steering lock ❶ is fitted on the steering column.  
The steering lock can be used to lock the steering. This makes steering impossible and the vehicle cannot be ridden.

## Locking the steering

### Note

**Danger of damage** The parked vehicle may roll away or fall over.

- Always place the vehicle on a firm and even surface.

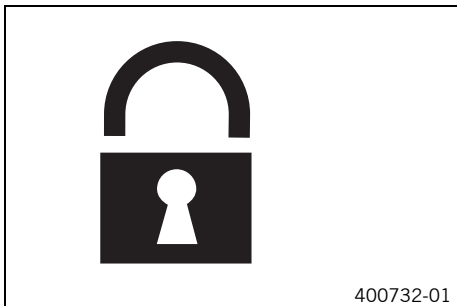

- Park the vehicle.
  - Move the handlebar to the straight-ahead position.
  - Insert the key into the steering lock, turn it to the left, press it in and turn it to the right. Pull out the key.
- ✓ Steering is no longer possible.



### Info

Never leave the key in the steering lock.

## Unlocking the steering



- Insert the key into the steering lock, turn it to the left, pull it out and turn it to the right. Pull out the key.
- ✓ The vehicle can be steered again.



### Info

Never leave the key in the steering lock.



## Advice on first use



### Danger

**Danger of accidents** Danger arising from the rider's judgement being impaired.

- Do not operate the vehicle while under the influence of alcohol, drugs and certain medications or physically or mentally impaired.



### Warning

**Danger of accidents** Unaccustomed handling of the ATV.

- If you have never ridden an ATV before, it is important that you participate in a driver training course before you ride the vehicle for the first time.
- A professional trainer will show you how to handle your ATV safely in various riding situations and on different terrain. Your KTM dealer will be glad to advise you.



### Warning

**Risk of injury** Missing or poor protective clothing present an increased safety risk.

- Wear protective clothing (helmet, boots, gloves, pants and jacket with protectors) every time you ride the vehicle. Always wear protective clothing, which must be undamaged and meet legal requirements.



### Warning

**Danger of crashing** Poor vehicle handling due to different tire tread patterns on front and rear wheels.

- The front and rear wheels must be fitted with tires with similar tread patterns to prevent loss of control over the vehicle.



### Warning

**Danger of accidents** Critical riding behavior due to inappropriate riding.

- Adapt your riding speed to the road conditions and your riding ability.



### Warning

**Danger of accidents** Accident risk caused by presence of a passenger.

- Your vehicle is not designed to carry passengers. Do not ride with a passenger.



## Warning

**Danger of accidents** Unstable riding behavior.

- Do not exceed the maximum permissible weight and axle loads.



## Warning

**Risk of misappropriation** Usage by unauthorized persons.

- Never leave the vehicle unattended while the engine is running. Secure the vehicle against use by unauthorized persons. Switch off the engine, pull out the ignition key and lock the steering lock.



## Warning

**Danger of accidents** Instable handling from loaded luggage.

- The vehicle is not designed to carry luggage. Do not attach luggage to the vehicle.



## Info

When using your vehicle, remember that others may feel disturbed by excessive noise.

- Make sure that the pre-delivery inspection work has been carried out by an authorized KTM workshop. You receive a delivery certificate and the service record at vehicle handover.
- Before your first trip, read the entire owner's manual thoroughly.
- Get to know the controls.
- Adjust the basic position of the clutch lever. (☞ p. 124)
- Adjust the basic position of hand brake lever. (☞ p. 126)
- Adjust the basic position of the foot brake lever. ☞ (☞ p. 137)
- Become accustomed to handling the vehicle on a suitable piece of land before making a longer trip.
- Do not use the vehicle in ways that demands skills beyond your ability and experience.
- Hold the handlebar firmly with both hands and keep your feet on the footrests when riding.

- Do not exceed the overall maximum permitted weight and the axle loads.

Guideline

Maximum permissible overall weight	335 kg (739 lb.)
Maximum allowable axle load	
Front	160 kg (353 lb.)
Rear	190 kg (419 lb.)

- Run the engine in.

## Running in the engine

- During the running-in phase, do not exceed the specified engine speed and engine performance.

Guideline

Maximum engine speed	
During the first operating hour	7,000 rpm
Maximum engine performance	
During the first 3 service hours	≤ 75 %

- Avoid fully opening the throttle!

## Checks and maintenance measures when preparing for use



### Info

Before each use, check the condition of the vehicle and its operating safety.  
The vehicle must be in perfect technical condition when it is being operated.

- Check the engine oil level. (☛ p. 173)
- Check the electrical system.
- Check the front brake fluid level. (☛ p. 128)
- Check the rear brake fluid level. (☛ p. 138)
- Check the front brake linings. (☛ p. 131)
- Check the rear brake linings. (☛ p. 140)
- Check that the brake system is functioning properly.
- Check the coolant level. (☛ p. 160)
- Check the chain dirt accumulation. (☛ p. 114)
- Check the chain, rear sprocket, engine sprocket, and chain guide. (☛ p. 118)
- Check the chain tension. (☛ p. 115)
- Check the tire condition. (☛ p. 147)
- Check the tire air pressure. (☛ p. 148)
- Check the air filter.
- Check the settings of all controls and ensure that they can be operated smoothly.
- Check all screws, nuts and hose clamps regularly for tightness.
- Check the fuel supply.

## Starting



### Danger

**Danger of poisoning** Exhaust gases are poisonous and inhaling them may result in unconsciousness and/or death.

- When running the engine, always make sure there is sufficient ventilation, and do not start or run the engine in an enclosed space without an effective exhaust extraction system.

### Note

**Engine failure** High engine speeds in cold engines have a negative effect on the service life of the engine.

- Always warm up the engine at low engine speeds.



### Info





If the engine is unwilling to start, the cause can be old fuel in the float chamber. The flammable elements of the fuel evaporate if the fuel stands for an extended period.

If the float chamber is filled with fresh fuel, the engine starts immediately.

Press the starter for a maximum of 5 seconds. Wait for a least 5 seconds before trying again.

### Condition

Vehicle has not been operated:  $\geq 1$  week

- Empty the carburetor float chamber.  (  p. 169)
- Turn the handle  of the fuel tap to **ON**. (Figure 100013-10  p. 42)
- ✓ Fuel can flow from the tank to the carburetor.

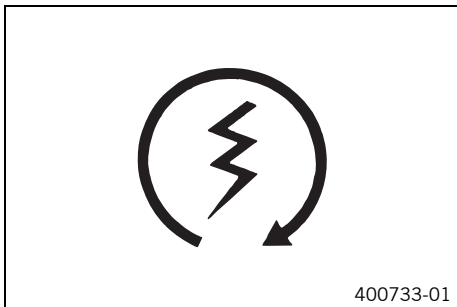

- Mount the vehicle.
  - Check the steering angle.
    - » If steering is not possible.
      - Unlock the steering. (☛ p. 46)
  - Insert the clip ② into the emergency OFF switch and fasten the rip cord to the clothing of the rider. (Figure 601084-10☛ p. 26)
  - Turn the key in the ignition switch to the position ○.
- ✓ The yellow ignition indicator lamp **ON** lights up.

**i** **Info**

Under no circumstances should you open the throttle while switching on the ignition!

The vehicle is equipped with a safety system that switches off the engine in case of a malfunction in the throttle lever, throttle cable or carburetor. When the ignition is switched on, a system check is performed during which the throttle lever must be in its basic position. If not, the safety system detects a malfunction and blocks the ignition current. When the electric starter button is activated, the electric starter turns over the engine, but the engine does not start because there is no ignition spark.

- Shift gear to neutral.
- ✓ The green idling speed indicator lamp **N** light up.

**Condition**

The engine is cold

- Pull choke lever out as far as possible.

**Condition**

The engine is hot

- Pull the hot start button (red) all the way out.

- Pull the clutch lever.
- Press the electric starter button.

**Info**

When the clutch lever is not pulled, the starting circuit is not closed. The electric starter does not turn over when the electric starter button is pressed. Do not open the throttle.

---

- Release the clutch lever.

**Condition**

The engine is hot and running

- Push the hot start button in as far as possible when the engine is running.

## Starting up

---

**Info**

Switch on the light before riding the vehicle. You will then be seen earlier by other motorists.

---

- Move the parking brake lever ① to the basic position. (Figure 601044-10 p. 21)
  - ✓ The parking brake in the rear is deactivated.
- Pull the hand brake lever and release it again.
  - ✓ Locking pawl moves into its basic position; front parking brake is deactivated.
- Pull the clutch lever, engage 1st gear, release the clutch lever slowly and simultaneously open the throttle carefully.

## Shifting



### Warning

**Danger of accidents** If you change down at high engine speed, the rear wheels can lock.

- Do not change into a low gear at high engine speed. The engine races and the rear wheels can lock.

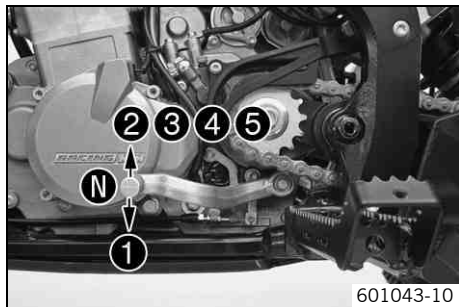

- When conditions allow (incline, road situation, etc.), you can shift into a higher gear.
- Release the throttle while simultaneously pulling the clutch lever, shift into the next gear, release the clutch and open the throttle.



### Info

The position of the 5 forward gears can be seen in the illustration. First gear is used for starting off or for steep inclines.

- To shift down, brake if necessary and close the throttle at the same time.
- Pull the clutch lever and shift into a lower gear, release the clutch lever slowly and open the throttle or shift again.

## Braking



### Warning

**Danger of accidents** If you brake too hard, the wheels can lock. When the front wheels lock, the vehicle can no longer be steered.

- Adapt your braking to the traffic situation and the road conditions.



### Warning

**Danger of accidents** Reduced braking efficiency caused by spongy pressure point of front or rear brake.

- Check the brake system and do not continue riding. (Your authorized KTM workshop will be glad to help.)





## Warning

**Danger of accidents** Reduced braking efficiency due to wet or dirty brakes.

- Clean or dry dirty or wet brakes by riding and braking gently.
- 



## Info

Use the hand brake lever to activate the front brakes and the foot brake lever to activate the brakes of all four wheels.

---

- When braking, release the throttle and apply the front and foot brakes at the same time.
- Shift the transmission to lower gears according to the vehicle's speed.
- Braking should always be completed before you go into a bend.
- On long downhill stretches, use the braking effect of the engine. Change down one or two gears, but do not overstress the engine. In this way, you will need to apply the brakes less often and the brakes will not overheat.

## Riding

---



## Info

If you hear unusual noises while riding, stop immediately, switch off the engine and contact an authorized KTM workshop. If the vehicle goes out of control and you fall off the vehicle, the clip of the emergency OFF switch is pulled off by the rip cord attached to your clothing. This short-circuits the ignition circuit and the engine switches off.

---

- During normal operation, you sit erect on the vehicle with both hands on the handlebar and both feet on the footrests.
- If the choke function was activated, deactivate it after the engine has warmed up.
- After reaching maximum speed by fully opening the throttle, close the throttle so it is 3/4 open.
  - ✓ This barely reduces vehicle speed but lowers fuel consumption considerably.
- Always open the throttle only as much as the engine can handle – abrupt pressure on the throttle increases fuel consumption.
- Switch off the engine if you expect to be standing for a long time.

## Guideline

≥ 2 min

- Avoid slipping the clutch frequently and for prolonged periods. This heats the engine oil, the engine and the cooling system.
- Ride with a lower engine speed instead of with a high engine speed and a slipping clutch.

## Riding in bends



### Info

When riding in bends, the outer wheels cover a greater distance than the inner wheels. Because the rear axle of the ATV is rigid in design, the rear wheels turn at the same speed. The difference in distance is compensated by slippage of the tires.

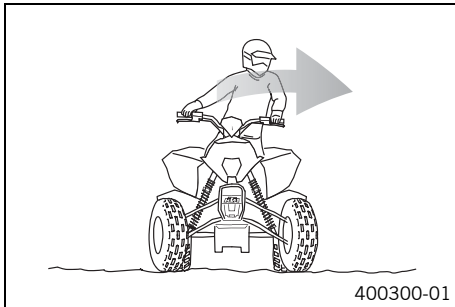

### Warning

**Danger of accidents** Excessive speed and turning at sharp angles can cause the vehicle to roll over.

- Decrease your speed before entering into bends.
- 
- Handling of the ATV is strongly influenced by shifts in the position of your body weight. Always shift your body weight toward the inside of the bend and forward.
  - The faster you ride and the tighter the bend, the more you need to shift your body weight.
  - Always exert pressure on the footrest on the inside of the bend.
  - Look in the direction of the bend while you are riding.
  - The farther back you are sitting, the more the vehicle has the tendency to move straight ahead. The farther forward you shift your weight, the more pressure is applied to the front axle and the more easily the vehicle can take the bend.

## Riding downhill

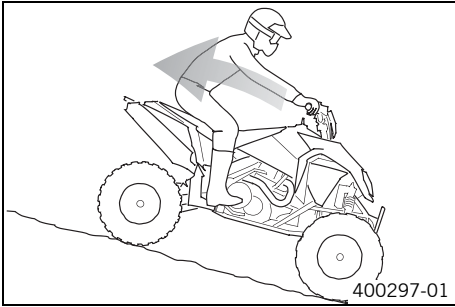

### Warning

**Danger of accidents** Danger of accidents when riding uphill and downhill.

- Always check the terrain before riding uphill or downhill.
- Never ride on a road or path with an uphill or downhill inclination of more than 25°.
- Never ride on a road or path that exceeds your riding skills.
- When you come to a standstill, always dismount from the vehicle and turn it.
- Never ride on a road or path with a slippery surface. The vehicle can easily go out of control and roll over.

### Note

**Material damage** Damage to vehicle after fall or rollover.

- Perform a vehicle check as is done every time before you start to ride.
- 
- Always ride straight up or down a slope and never at a slant.
  - Engage a gear with which you can ride all the way down the slope without shifting.
  - Shift your body weight to the rear and ride cautiously without opening the throttle.
  - Keep your vehicle speed and engine speed as constant as possible.
  - Brake by mainly applying the foot brake; the rear wheels should not become locked.

## Riding uphill

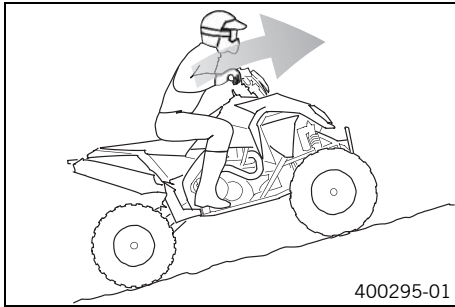

### Warning

**Danger of accidents** Danger of accidents when riding uphill and downhill.

- Always check the terrain before riding uphill or downhill.
  - Never ride on a road or path with an uphill or downhill inclination of more than 25°.
  - Never ride on a road or path that exceeds your riding skills.
  - When you come to a standstill, always dismount from the vehicle and turn it.
  - Never ride on a road or path with a slippery surface. The vehicle can easily go out of control and roll over.
- 
- Always ride straight up or down a slope and never at a slant.
  - Engage a gear with which you can ride all the way up the slope without shifting. Shifting on the slope can cause the vehicle to roll over.
  - Shift your body weight to the front and ride cautiously.
  - Keep your vehicle speed and engine speed as constant as possible.
  - Drive slowly over hilltops to give yourself the opportunity to react to obstacles and changes in terrain.
  - If the vehicle comes to a stop, immediately activate both brakes to prevent the vehicle from rolling backward. Dismount from the vehicle and turn it.

## Riding perpendicular to the slope

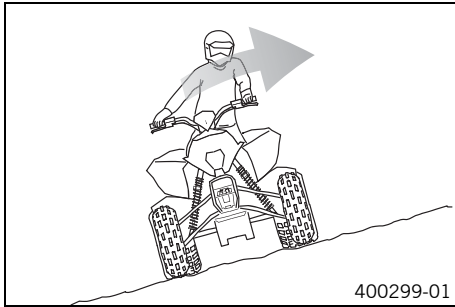

### Warning

**Danger of accidents** When riding perpendicular to a slope, the vehicle can tip easily and roll over.

- Avoid riding perpendicular to the slope if possible.
  - Ride slowly and shift your weight toward the slope.
- 
- When the vehicle first begins tipping, steer the vehicle downhill and immediately dismount on the uphill side.

## Turning on slopes



### Warning

**Danger of accidents** Danger of accidents from turning the vehicle on a slope.

- Never ride down a slope backward. The vehicle can roll over easily.
- Always position yourself next to the vehicle in a location where you cannot be caught by a wheel.
- When turning on a slope, always stand on the uphill side of the vehicle to avoid injury should the vehicle tip.
- If the slope is too steep or slippery to turn the vehicle, you should leave it where it is and get assistance in retrieving it.

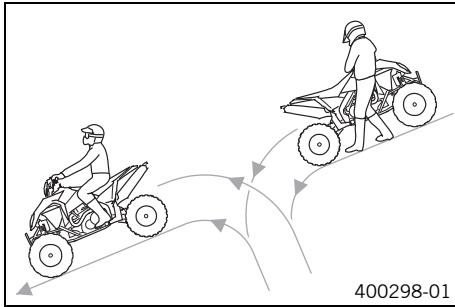

- If you come to a stop on a slope with your vehicle, dismount from the vehicle and turn it.
- Switch off the engine and apply the parking brakes.

---

**i** **Info**

A gear must be engaged.

---

- Dismount from the vehicle on the uphill side.
- Grasp the handlebar with both hands, release the parking brakes and carefully pull the clutch.
- Let the vehicle roll downhill carefully until you reach a location where you can turn it. Control its speed using the clutch.
- To turn the vehicle, steer it to the side. When doing so, you should always stand on the uphill side and apply pressure to the footrest on the uphill side.
- When the vehicle is standing perpendicular to the slope or slightly downhill, apply the parking brakes.
- Mount the vehicle, start the engine, pull the clutch lever and engage 1st gear. Cautiously release the parking brakes and ride downhill in 1st gear.
- Ride downhill. (👉 p. 57)
- If you lose control over the vehicle, you should get away from the vehicle as fast as possible.

## Riding through water

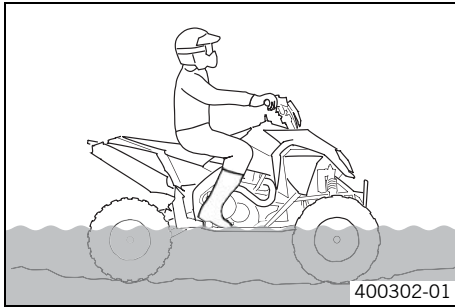

### Warning

**Danger of accidents** The vehicle can roll over when riding through deep water with a strong current.

- Avoid riding through deep water with a strong current.



### Warning

**Danger of accidents** Reduced braking efficiency due to wet or dirty brakes.

- Clean or dry dirty or wet brakes by riding and braking gently.

### Note

**Engine failure** When riding through deep water, water can enter into the engine through the air filter and cause engine damage.

- Only ride through water if it reaches no higher than the upper edge of the footrest.
- 
- Before riding through water, determine the depth and current of the water.
  - Ride slowly and negotiate around obstacles.
  - After riding through water, dry the brakes by lightly activating both brakes until normal braking power is available again.
  - If the vehicle became submerged, an authorized KTM workshop must perform a thorough check and comprehensive service. Do not start the engine.

## Switching off the engine



### Info

There are three ways to switch off the engine.



400739-01

## Alternative 1

Switch off the engine using the ignition key.

- Turn the key in the ignition switch to the position ☒ while the engine is idling.



### Info

All power consumers are switched off.

## Alternative 2

Switch off the engine using the kill switch.

- Press the kill switch ☒ at engine idle speed until the engine stops.



### Info

When the engine is switched off using the kill switch, the power consumers are not switched off. All power consumers that are switched on (headlights, tail lights, etc.) continue consuming electricity. This uses battery power and causes it to discharge.

## Alternative 3

Switch off the engine using the emergency OFF switch with a rip cord.

- Pull off clip ②. (Figure 601084-10 p. 26)



### Info

When the engine is switched off using the emergency OFF switch, the power consumers are not switched off. All power consumers that are switched on (headlights, tail lights, etc.) continue consuming electricity. This uses battery power and causes it to discharge.



## Stopping, parking



### Warning

**Danger of burns** Some vehicle components become very hot when the vehicle is operated.

- Do not touch hot components such as exhaust system, radiator, engine, shock absorber and brakes. Allow these components to cool down before starting work on them.

### Note

**Danger of damage** Danger of damage from accidental rolling of vehicle.

- Park the vehicle on a surface that is as horizontal as possible and apply the parking brakes.

### Note

**Fire hazard** Some vehicle components become very hot when the vehicle is operated.

- Do not park the vehicle near flammable or explosive substances. Do not place objects on the vehicle while it is still warm from being run. Always let the vehicle cool first.

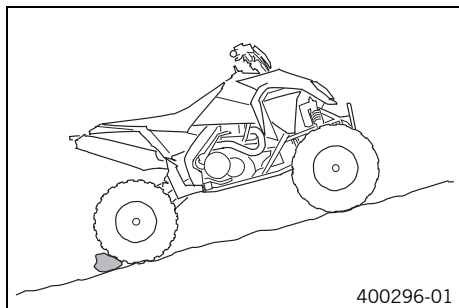

- Stop the vehicle and park it on a surface that is as horizontal as possible.
- Shift gear to neutral.
  - ✓ The green idling speed indicator lamp **N** light up.
- Switch off the engine. (☛ p. 61)
- Remove the ignition key and the clip from the emergency OFF switch.
- Fold down the parking brake lever ❶. (Figure 601044-10☛ p. 21)
  - ✓ The rear wheels are locked.
- Pull the hand brake lever, push the locking pawl ❷ down and release the hand brake lever. (Figure 302856-10☛ p. 20)
  - ✓ The front wheels are locked.
- Turn the handle ❶ of the fuel tap to **OFF**. (Figure 100013-10☛ p. 42)

- ✓ No more fuel flows from the tank to the carburetor.
- If the vehicle must be parked on an incline, additionally secure the rear wheels against rolling (see illustration).

## Refueling



### Danger

**Fire hazard** Fuel is highly flammable.

- Never refuel the vehicle near open flames or burning cigarettes, and always switch off the engine first. Be careful that no fuel is spilt, especially on hot vehicle components. Clean up spilt fuel immediately.
- Fuel in the fuel tank expands when warm and can escape if the tank is overfilled. See the notes on refueling.



### Warning

**Danger of poisoning** Fuel is poisonous and a health hazard.

- Avoid contact of the fuel with skin, eyes and clothing. Do not inhale fuel vapors. If fuel gets into your eyes, rinse immediately with water and contact a doctor. Wash affected skin areas immediately with soap and water. If fuel is swallowed, contact a doctor immediately. Change clothing that has come into contact with fuel.



### Warning

**Environmental hazard** Improper handling of fuel is a danger to the environment.

- Do not allow fuel to get into the ground water, the ground, or the sewage system.

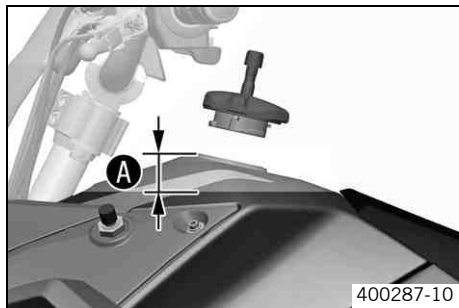

- Switch off the engine.
- Open the filler cap. (☛ p. 41)
- Fill the fuel tank with fuel up to measurement **A**.

Guideline

Measurement of <b>A</b>	35 mm (1.38 in)
-------------------------	-----------------

Total fuel tank capacity approx.	13.5 l (3.57 US gal)	Super unleaded (ROZ 95 / RON 95 / PON 91) (☛ p. 209)
----------------------------------	-------------------------	--

- Close the filler cap. (☛ p. 41)

## Service schedule

	S1N	S15A	S30A
Check that the electrical equipment is functioning properly.	•	•	•
Check and charge the battery. 🛠️		•	•
Change the engine oil and oil filter, clean the oil screens. 🛠️ (📖 p. 174)	•	•	•
Check the front brake linings. (📖 p. 131)		•	•
Check the rear brake linings. (📖 p. 140)		•	•
Check the brake discs. (📖 p. 127)		•	•
Check the brake lines for damage and leakage.		•	•
Check the rear brake fluid level. (📖 p. 138)		•	•
Check the free travel of the foot brake lever. (📖 p. 136)		•	•
Check the frame and swingarm. 🛠️		•	•
Check the swingarm bearing. 🛠️			•
Check the heim joints on the upper and lower shock absorbers. 🛠️		•	•
Check the tire condition. (📖 p. 147)	•	•	•
Check the tire air pressure. (📖 p. 148)	•	•	•
Check the wheel bearing for play. 🛠️		•	•
Check the wheel hubs. 🛠️		•	•
Check for rim run-out. 🛠️	•	•	•
Check the front wheel suspension. 🛠️		•	•
Check the chain, rear sprocket, engine sprocket, and chain guide. (📖 p. 118)		•	•
Check the chain tension. (📖 p. 115)	•	•	•
Lubricate the rear wheel eccentric element. 🛠️		•	•

	S1N	S15A	S30A
Check the parking brake. 🛠️	•	•	•
Lubricate all moving parts (e. g. hand levers, chain, ...) and check for smooth operation. 🛠️		•	•
Check the fluid level of the hydraulic clutch. (🔧 p. 124)		•	•
Check the front brake fluid level. (🔧 p. 128)		•	•
Check the free travel of the hand brake lever. (🔧 p. 126)		•	•
Check the bearing clearance of the steering column.	•	•	•
Check the bearing of the handlebar bridge. 🛠️		•	•
Check the valve clearance. 🛠️	•	•	•
Check the clutch. 🛠️			•
Check all hoses (e. g. fuel, cooling, bleeding, drainage) and sleeves for tearing, tightness, and correct routing. 🛠️	•	•	•
Check the antifreeze and coolant level. (🔧 p. 159)	•	•	•
Check the cables for damage and routing without sharp bends. 🛠️		•	•
Check the cables for damage, routing without sharp bends, and correct adjustment.	•	•	•
Clean the air filter and air filter box. 🛠️		•	•
Change glass fiber yarn filling of main silencer. 🛠️			•
Check the screws and nuts for tightness. 🛠️	•	•	•
Check the headlight setting. (🔧 p. 156)	•	•	•
Check the idle. 🛠️	•	•	•
Check that the radiator fan is functioning properly. 🛠️	•	•	•
Final inspection: check the vehicle for operating safety and take a test ride.	•	•	•
Create a service entry in the <b>KTM DEALER.NET</b> and in the service record. 🛠️	•	•	•

**S1N:** Once after one operating hour

**S15A:** Every 15 operating hours

**S30A:** Every 30 operating hours

## Maintenance work (as an additional order)

	S45A	S90A	J1A
Change the brake fluid. 🛠️			•
Change the sealing sleeves of the foot brake cylinder. 🛠️			•
Change the hydraulic clutch fluid. 🛠️			•
Lubricate the steering column bearing. 🛠️			•
Check/adjust the carburetor components. 🛠️		•	•
Service the front shock absorber. 🛠️	•	•	
Service the rear shock absorber. 🛠️	•	•	
Change the spark plug and spark plug connector. 🛠️	•	•	
Change the piston. 🛠️		•	
Check/measure the cylinder. 🛠️		•	
Check the cylinder head. 🛠️		•	
Check the valves, valve springs, and valve spring seats. 🛠️		•	
Check the camshaft and rocker arm. 🛠️		•	
Change the connecting rod, conrod bearing, and crank pin. 🛠️		•	
Check the transmission and shift mechanism. 🛠️		•	
Check the oil pressure regulator valve. 🛠️		•	
Check the oil pumps and lubrication system. 🛠️		•	
Check the timing assembly. 🛠️		•	
Change all engine bearings. 🛠️		•	

# SERVICE SCHEDULE

---

**S45A:** Every 45 operating hours

**S90A:** Every 90 operating hours/every 45 operating hours after sporting use

**J1A:** Annually

## Basic information on changing the chassis settings

The standard setting of the chassis is the result of many fine tuning tests. It is laid out for the weight of the average rider (with a full set of protective clothing) and for a sporty driving style.

Average rider weight	70... 80 kg (154... 176 lb.)
----------------------	------------------------------

By making a variety of adjustments to the chassis, you can set it to better match your body weight and riding style.

The left and right front shock absorbers should have the same settings.

If your weight is above or below the average, you have to adjust the standard setting of the suspension components accordingly.

Small weight differences can be compensated by adjusting the spring preload, but in the case of large weight differences, the springs must be replaced.



### Tip

When changing the chassis settings, always start with the standard setting.

Between test rides, always change only one setting. This will enable you to better assess the effect of the setting on vehicle handling.

Do not make radical changes to the settings; proceed in small steps instead. Even small changes can have a large impact on vehicle handling.

## Front shock absorber - adjusting the compression damping



### Warning

**Danger of accidents** Modifications to the suspension settings can seriously alter the vehicle's ride behavior.

- Extreme modifications to the adjustment of the spring elements can cause a serious deterioration in the handling characteristics and overload some components.
- Only make adjustments within the recommended range.
- After making adjustments, ride slowly at first to get the feel of the new ride behavior.





## Caution

**Danger of accidents** Disassembly of pressurized parts can lead to injury.

- The shock absorber is filled with high density nitrogen. Adhere to the description provided. (Your authorized KTM workshop will be glad to help.)



## Info

The compression damping setting has an impact on the compression of the shock absorber.

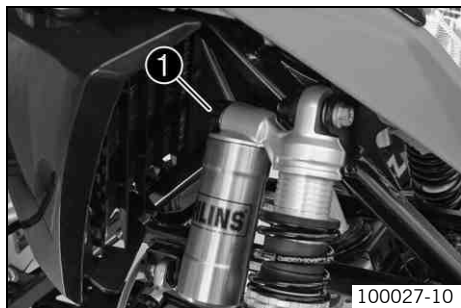

- Turn adjusting wheel ❶ clockwise up to the last perceptible click.
- Turn back counterclockwise by the number of clicks corresponding to the shock absorber type.

Guideline

**(Option: KT 770...)**

Compression damping	
Standard	14 clicks
Maximum deviation from standard value	-5... 5 clicks

**(Option: KT 870...)**

Compression damping	
Standard	15 clicks
Maximum deviation from standard value	-5... 5 clicks



## Tip

Experience has shown that settings outside of this range are detrimental to vehicle handling. When changing the chassis settings, always start with the standard setting.



## Info

Turn clockwise to increase damping; turn counterclockwise to reduce damping. The left and right shock absorbers should have the same settings.

---

## Front shock absorber - adjusting the rebound damping

---



## Warning

**Danger of accidents** Modifications to the suspension settings can seriously alter the vehicle's ride behavior.

- Extreme modifications to the adjustment of the spring elements can cause a serious deterioration in the handling characteristics and overload some components.
- Only make adjustments within the recommended range.
- After making adjustments, ride slowly at first to get the feel of the new ride behavior.



## Caution

**Danger of accidents** Disassembly of pressurized parts can lead to injury.

- The shock absorber is filled with high density nitrogen. Adhere to the description provided. (Your authorized KTM workshop will be glad to help.)
- 



## Info

The rebound damping setting has an impact on the rebound of the shock absorber.

---



- Turn adjusting screw ❶ clockwise up to the last perceptible click.
- Turn back counterclockwise by the number of clicks corresponding to the shock absorber type.

Guideline

**(Option: KT 770...)**

Rebound damping	
Standard	20 clicks
Maximum deviation from standard value	-5... 5 clicks

**(Option: KT 870...)**

Rebound damping	
Standard	20 clicks
Maximum deviation from standard value	-5... 5 clicks

**i Tip**

Experience has shown that settings outside of this range are detrimental to vehicle handling. When changing the chassis settings, always start with the standard setting.

**i Info**

Turn clockwise to increase damping; turn counterclockwise to reduce damping. The left and right shock absorbers should have the same settings.

## Front shock absorber - adjusting the spring preload



### Warning

**Danger of accidents** Modifications to the suspension settings can seriously alter the vehicle's ride behavior.

- Extreme modifications to the adjustment of the spring elements can cause a serious deterioration in the handling characteristics and overload some components.
- Only make adjustments within the recommended range.
- After making adjustments, ride slowly at first to get the feel of the new ride behavior.



### Caution

**Danger of accidents** Disassembly of pressurized parts can lead to injury.

- The shock absorber is filled with high density nitrogen. Adhere to the description provided. (Your authorized KTM workshop will be glad to help.)



### Info

Increasing the spring preload raises the center of gravity of the vehicle. This can have a large impact on vehicle handling.



### Tip

Before you change the spring preload, make a note of the groove in which the securing clip is positioned. When making adjustments, always start from the standard setting.

- Raise the vehicle with the lifting gear. (🔧 p. 88)
- Clean the shock absorber thoroughly.

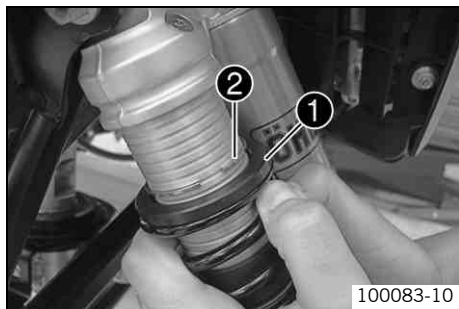

- Press the spring pack and the spring retainer ❶ down to make the securing clip ❷ accessible.
- Using pliers, position the locking clip in one of the upper grooves. Do not overstrain the securing clip.
- Release the spring pack and measure the length of the unloaded spring pack.

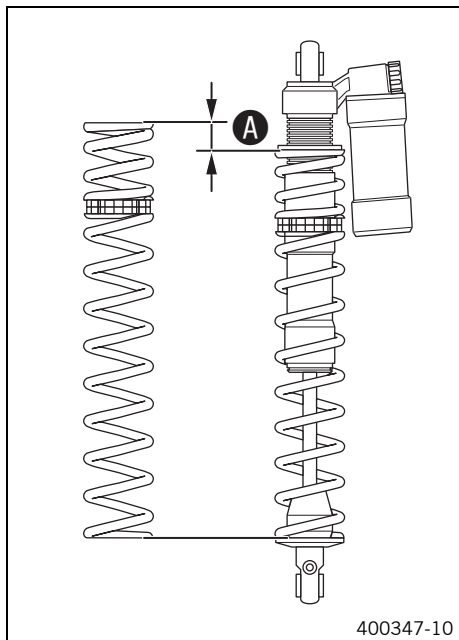

- Press together the spring pack, position the securing clip in the corresponding groove and release the spring pack.

Guideline

**(Option: KT 770...)**

Clip position, spring preload	
Standard	7 th position from top
Corresponds to a spring preload of	5 mm (0.2 in)

**(Option: KT 870...)**

Clip position, spring preload	
Standard	8th position from top
Corresponds to a spring preload of	9 mm (0.35 in)



## Info

Spring preload **A** is the difference in length between the spring pack when it is unloaded and when it is installed.

The securing clip must be positioned entirely within the cut-out of the spring retainer.

The spring pack should never be installed loosely (without preload). The standard setting is the lowest permissible spring preload. Therefore, you can only increase the spring preload.

If you increase the spring preload, you should also slightly increase the rebound damping.

The left and right shock absorbers should have the same settings.

- Remove the vehicle from the lifting gear. (☛ p. 88)

## Front shock absorber - adjusting the cross over



### Warning

**Danger of accidents** Modifications to the suspension settings can seriously alter the vehicle's ride behavior.

- Extreme modifications to the adjustment of the spring elements can cause a serious deterioration in the handling characteristics and overload some components.
- Only make adjustments within the recommended range.
- After making adjustments, ride slowly at first to get the feel of the new ride behavior.



### Caution

**Danger of accidents** Disassembly of pressurized parts can lead to injury.

- The shock absorber is filled with high density nitrogen. Adhere to the description provided. (Your authorized KTM workshop will be glad to help.)

**i** Info

The cross over setting is used to adjust the suspension travel of the short (soft) spring. Greater cross over makes the spring action at the front softer and the front of the vehicle lies lower. The suspension travel and the progressive part of the long (hard) spring is not fully utilized. Less cross over makes the spring action at the front harder and the front of the vehicle lies higher.

- Adjust the spring preload for the front shock absorbers. (☛ p. 74)
- Raise the vehicle with the lifting gear. (☛ p. 88)
- Clean the shock absorber thoroughly.
- Loosen adjusting rings ① and ②.

Hook wrench (83019001000)

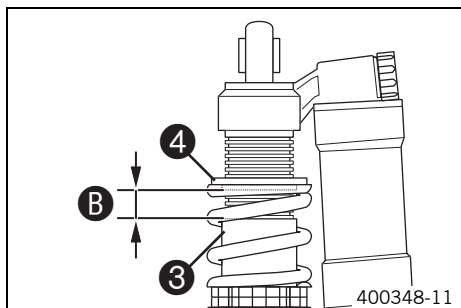
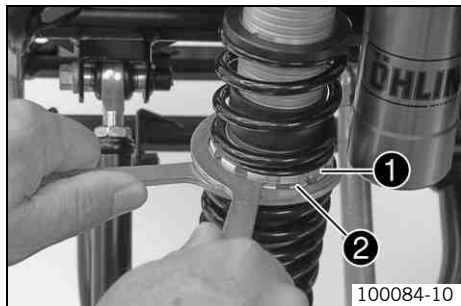

- The cross over setting ⑤ is measured between sliding bushing ③ and the collar of spring retainer ④.

Guideline

**(Option: KT 770...)**

Cross over	17±1.5 mm (0.67±0.059 in)
------------	---------------------------

**(Option: KT 870...)**

Cross over	14±1.5 mm (0.55±0.059 in)
------------	---------------------------

- Change the settings accordingly and lock the adjusting ring.

**Info**

The sliding bushing is made of plastic. Therefore, do not lock it too tightly to avoid damaging the thread.  
The left and right shock absorbers should have the same settings.

- 
- Remove the vehicle from the lifting gear. (🔧 p. 88)

## Rear shock absorber - adjusting the compression damping

**Warning**

**Danger of accidents** Modifications to the suspension settings can seriously alter the vehicle's ride behavior.

- Extreme modifications to the adjustment of the spring elements can cause a serious deterioration in the handling characteristics and overload some components.
- Only make adjustments within the recommended range.
- After making adjustments, ride slowly at first to get the feel of the new ride behavior.

**Caution**

**Danger of accidents** Disassembly of pressurized parts can lead to injury.

- The shock absorber is filled with high density nitrogen. Adhere to the description provided. (Your authorized KTM workshop will be glad to help.)

**Info**

The compression damping setting has an impact on the compression of the shock absorber.

---



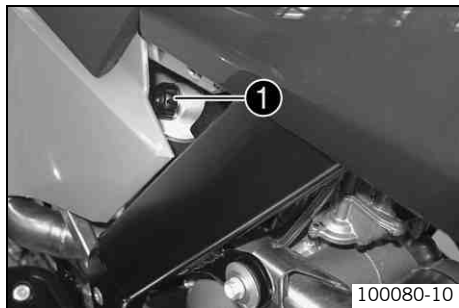

- Turn adjusting wheel ❶ clockwise up to the last perceptible click.
- Turn back counterclockwise by the number of clicks corresponding to the shock absorber type.

Guideline

**(Option: KT 771...)**

Compression damping	
Standard	15 clicks
Maximum deviation from standard value	-5... 5 clicks

**(Option: KT 871...)**

Compression damping	
Standard	17 clicks
Maximum deviation from standard value	-5... 5 clicks

**i Tip**

Experience has shown that settings outside of this range are detrimental to vehicle handling. When changing the chassis settings, always start with the standard setting.

**i Info**

Turn clockwise to increase damping; turn counterclockwise to reduce damping.

## Rear shock absorber - adjusting the rebound damping



### Warning

**Danger of accidents** Modifications to the suspension settings can seriously alter the vehicle's ride behavior.

- Extreme modifications to the adjustment of the spring elements can cause a serious deterioration in the handling characteristics and overload some components.
- Only make adjustments within the recommended range.
- After making adjustments, ride slowly at first to get the feel of the new ride behavior.



### Caution

**Danger of accidents** Disassembly of pressurized parts can lead to injury.

- The shock absorber is filled with high density nitrogen. Adhere to the description provided. (Your authorized KTM workshop will be glad to help.)



### Info

The rebound damping setting has an impact on the rebound of the shock absorber.

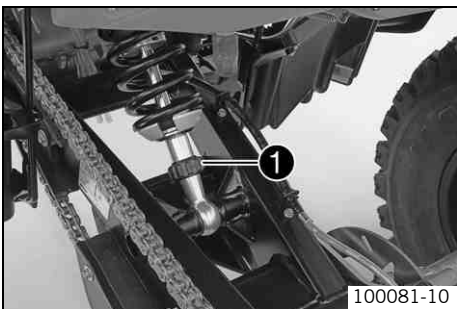

- Turn the adjusting wheel ❶ to the right until it stops.
- Turn back to the left by the number of clicks corresponding to the shock absorber type.

Guideline

**(Option: KT 771...)**

Rebound damping	
Standard	15 clicks
Maximum deviation from standard value	-5... 5 clicks

(Option: KT 871...)

Rebound damping	
Standard	15 clicks
Maximum deviation from standard value	-5... 5 clicks



### Tip

Experience has shown that settings outside of this range are detrimental to vehicle handling. When changing the chassis settings, always start with the standard setting.



### Info

Turning to the right increases damping, while turning to the left lessens damping.

## Rear shock absorber - adjusting the spring preload



### Warning

**Danger of accidents** Modifications to the suspension settings can seriously alter the vehicle's ride behavior.

- Extreme modifications to the adjustment of the spring elements can cause a serious deterioration in the handling characteristics and overload some components.
- Only make adjustments within the recommended range.
- After making adjustments, ride slowly at first to get the feel of the new ride behavior.



### Caution

**Danger of accidents** Disassembly of pressurized parts can lead to injury.

- The shock absorber is filled with high density nitrogen. Adhere to the description provided. (Your authorized KTM workshop will be glad to help.)

**i** Info

Increasing the spring preload raises the center of gravity of the vehicle. This can have a large impact on vehicle handling.

**i** Tip

Before changing the spring preload, make a note of the present setting, e.g., by measuring the length of the spring.

- Remove the rear shock absorber. 🛠️ (📖 p. 88)
- After removing the shock absorber, clean it thoroughly.
- Release lock nut ❶ while holding adjusting ring ❷.

Hook wrench (83019002000)

**i** Info

Do not loosen lock nut ❸ at the top of the shock absorber.

- Turn the adjusting ring until the spring is no longer under tension.

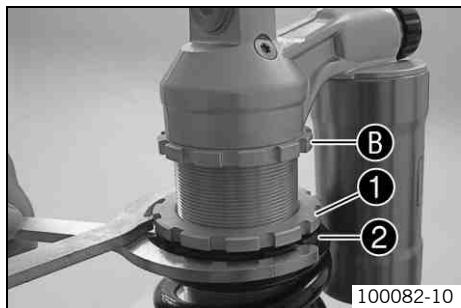

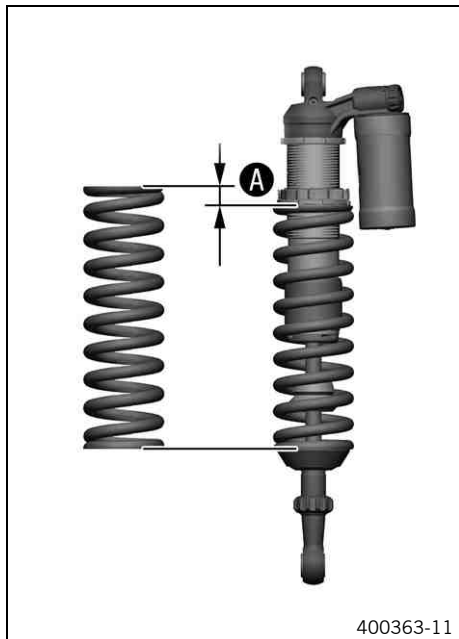

- Measure the overall spring length in an unloaded state.

**i Info**

The spring preload **A** is the difference in length between the spring when it is unloaded and when it is installed.

- Tighten the spring by turning the adjusting ring to specified measurement.

Guideline

**(Option: KT 771...)**

Spring preload	
Standard	3 mm (0.12 in)

**(Option: KT 871...)**

Spring preload	
Standard	3 mm (0.12 in)

- Tighten the lock nut and the adjusting ring.

**i Info**

The adjusting ring **B** is made of plastic. Therefore, do not lock the adjusting ring too tightly to avoid damaging the thread.

If you increase the spring preload, you should also slightly increase the rebound damping.

- Install the rear shock absorber. 🛠️ (📖 p. 90)

## Handlebar position

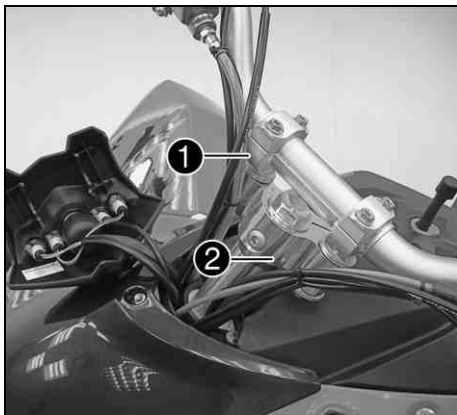

The handlebar position can be adjusted 4-fold by turning the handlebar support **1** and the handlebar support **2**.

The holes on the handlebar support are placed at a distance of **A** from the center.

Distance <b>A</b> between holes	3.5 mm (0.138 in)
---------------------------------	-------------------

The holes on the handlebar bridge are placed at a distance of **B** from the center.

Distance <b>B</b> between holes	7.5 mm (0.295 in)
---------------------------------	-------------------

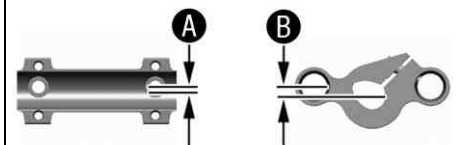

100098-10

## Adjusting the handlebar position



- Pull the instrument support off the handlebar and swing it to the side.



### Info

Protect the vehicle and its attachments from damage by covering them.  
Do not bend the cables and lines.

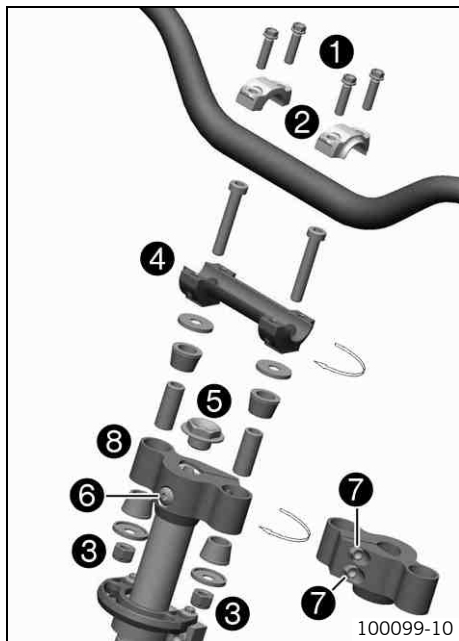

- Remove the four screws ❶. Remove handlebar clamps ❷, swing the handlebar forward and set it down.
- Remove nuts ❸ and remove handlebar support ❹ with the screws.
- Remove screws ❺ and ❻.
- Remove screws ❼. Remove handlebar bridge ❽.
- Place handlebar bridge ❽ onto the steering column in the desired position. Mount and tighten screw ❻.

Guideline

Screw, steering bridge	M8	20 Nm (14.8 lbf ft)
------------------------	----	------------------------

- Mount and tighten screw ❺.

Guideline

Screw, steering column, top	M20x1.5	25 Nm (18.4 lbf ft)
-----------------------------	---------	------------------------

- Mount and tighten screws ❼.

Guideline

Screw, steering bridge	M8	20 Nm (14.8 lbf ft)
------------------------	----	------------------------

- Mount handlebar support ❹ in the desired position using the screws. Mount new self-locking nuts ❸ and tighten.

Guideline

Nut, handlebar support	M10	45 Nm (33.2 lbf ft)
------------------------	-----	------------------------

- Position the handlebar and fix it with handlebar clamps ❷. Mount and tighten screws ❶.



## Guideline

Screw, handlebar clamp	M8	20 Nm (14.8 lbf ft)
------------------------	----	------------------------



### Info

Make sure cables and wiring are positioned correctly.

- Position the instrument support on the handlebar.

## Raising the vehicle with the lifting gear



### Note

**Danger of damage** Danger of damage from tipping of vehicle.

- Jack up the vehicle on a firm and horizontal surface. Use a flex-free work stand.
- Raise the vehicle on the frame underneath the engine.
  - ✓ The wheels must no longer touch the ground.
- Secure the vehicle.

## Removing the vehicle from the lifting gear

### Note

**Danger of damage** The parked vehicle may roll away or fall over.

- Always place the vehicle on a firm and even surface.
- Lower the vehicle.
- Remove the lifting gear.

## Removing the rear shock absorber

- Raise the vehicle with the lifting gear. (🔧 p. 88)
- Remove the rear fender. (🔧 p. 94)

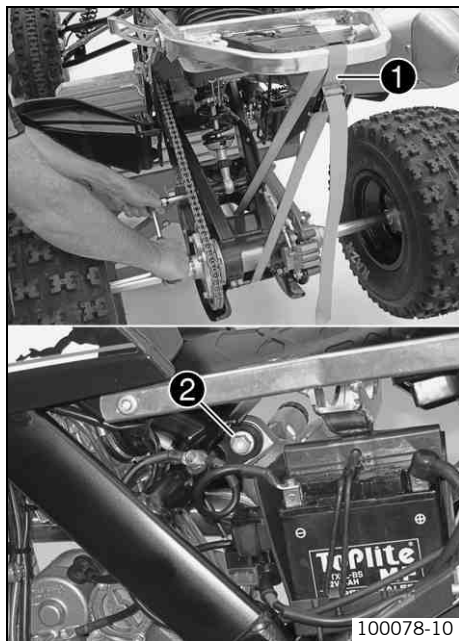

---

## Note

**Danger of damage** The chain sliding piece and frame can be damaged from incorrect handling.

- When removing the rear shock absorber, secure the swingarm with a tension belt to prevent it from swinging down further.

- 
- Attach the swingarm to the subframe with a tension belt **1** to relieve the shock absorber.
  - Remove the bottom screw of the shock absorber.

---

## i Tip

Press the screw out of the swingarm with a screw driver while moving the tension belt.

- 
- Remove the top screw **2** of the shock absorber and carefully remove the shock absorber out of the vehicle toward the rear.

## Installing the rear shock absorber



- Position the shock absorber in the vehicle with the reservoir on the right. Mount and tighten the top screw .



Guideline

Screw, rear top shock absorber	M12	60 Nm (44.3 lbf ft)
--------------------------------	-----	------------------------

- Position the shock absorber in the swingarm. Mount and tighten the bottom screw.

Guideline

Screw, rear bottom shock absorber	M12	70 Nm (51.6 lbf ft)
-----------------------------------	-----	------------------------

- Remove the tension belt.
- Install the rear fender. ( p. 95)
- Remove the vehicle from the lifting gear. ( p. 88)

## Removing the radiator spoiler



### Info

The operations are the same on the left and right.

- Remove the seat ( p. 97)

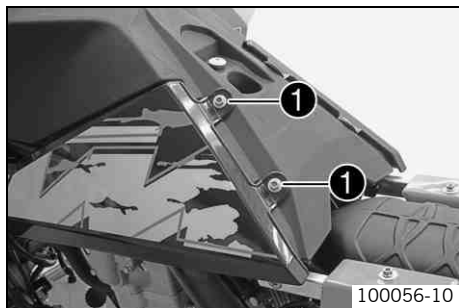

- Remove the screws ❶ on the fuel tank.

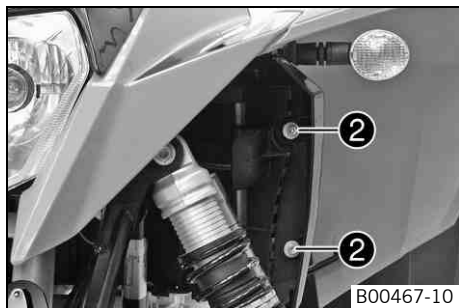

- Remove the screws ❷ on the radiator.
- Detach the radiator spoiler and remove it.

## Installing the radiator spoiler



### Info

The operations are the same on the left and right.

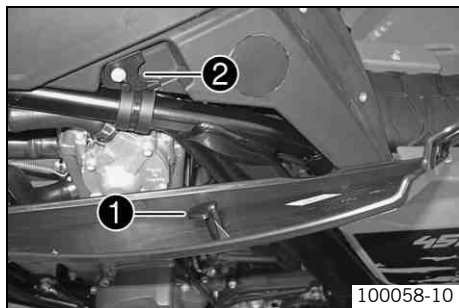

- Hook catch **1** of the radiator spoiler into holder **2** of the fuel tank and position it on the radiator.

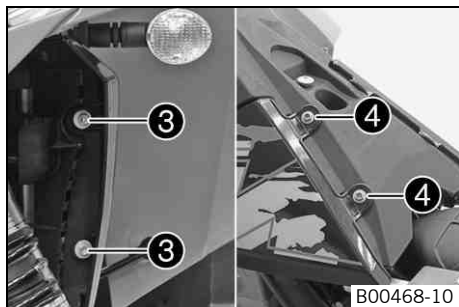

- Mount and tighten screws **3** on the radiator.

Guideline

Remaining screws, chassis	M6	10 Nm (7.4 lbf ft)
---------------------------	----	--------------------

- Mount and tighten screws **4** on the fuel tank.

Guideline

Screw on fuel tank	M6	6 Nm (4.4 lbf ft)
--------------------	----	-------------------

- Mount the seat. (👉 p. 97)

## Removing the front cover

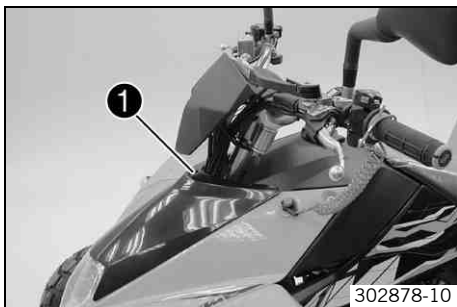

- Remove screw ❶.
- Slide the front cover up and remove it.

## Installing the front cover

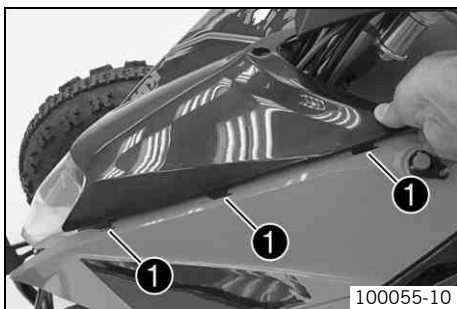

- Position the front cover in slots ❶ on both sides of the front trim.
- Mount and tighten the screw.

## Removing the rear fender

- Remove the seat (☛ p. 97)
- Remove screws ❶.

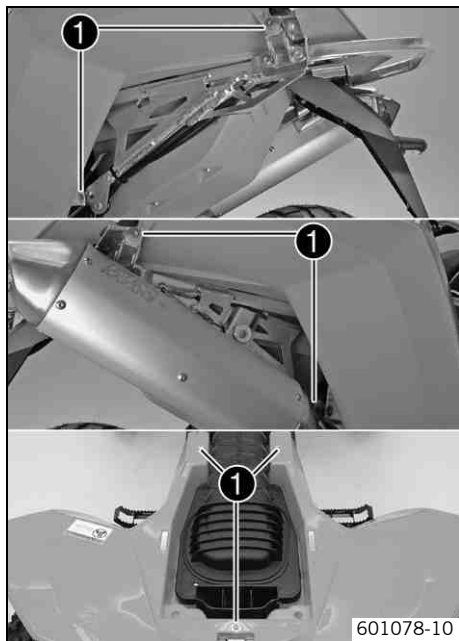



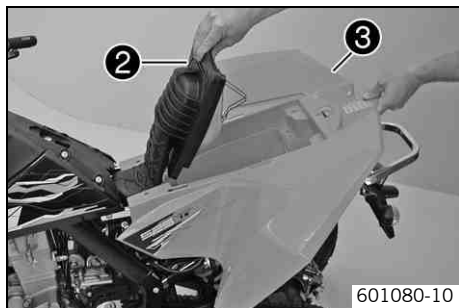

- Raise the rear of the air filter box lid ②. At the same time, use your other hand to press on the carburetor connection boot to kink it at that location.

**i** **Info**

This prevents the carburetor connection boot from disconnecting from the carburetor.

- Raise fender ③ at the rear and remove it.

## Installing the rear fender

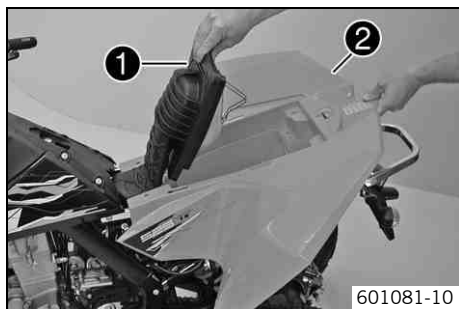

- Raise the rear of the air filter box lid ①. At the same time, use your other hand to press on the carburetor connection boot to kink it at that location.

**i** **Info**

This prevents the carburetor connection boot from disconnecting from the carburetor.

- Position front fender ②.
- Fix the air filter box lid in the fender.

**i** **Info**

If the air filter box lid is not correctly mounted, dust and dirt can penetrate into the engine and cause damage.

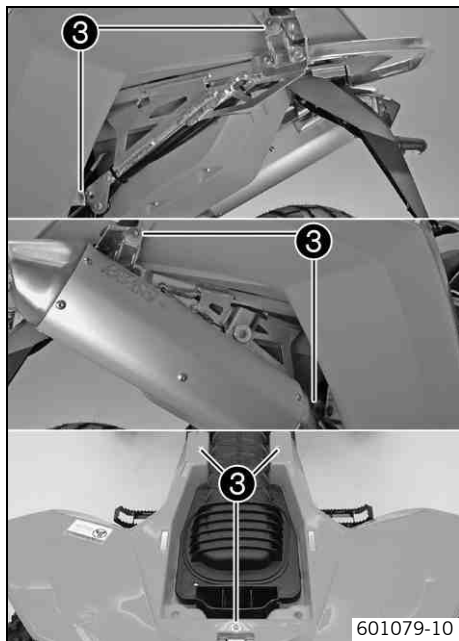

- Mount and tighten screws ③.

Guideline

Remaining screws, chassis	M6	10 Nm (7.4 lbf ft)
---------------------------	----	--------------------

- Mount the seat. (☛ p. 97)

## Removing the seat

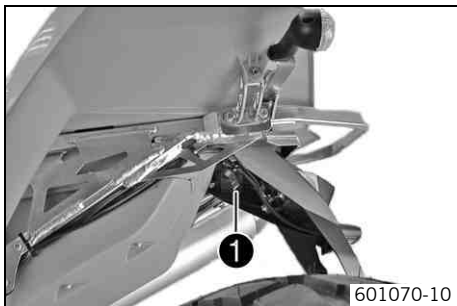

- Pull the release hook ❶ back. Lift up the seat at the rear, pull it back and then remove from above.

## Mounting the seat

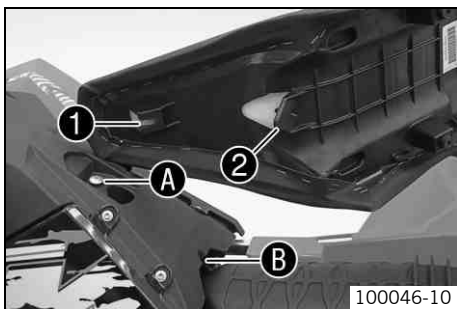

- Hook slot ❶ on the seat into collar sleeve A of the fuel tank, lower the rear of the seat and slide tab ❷ under fuel tank B.

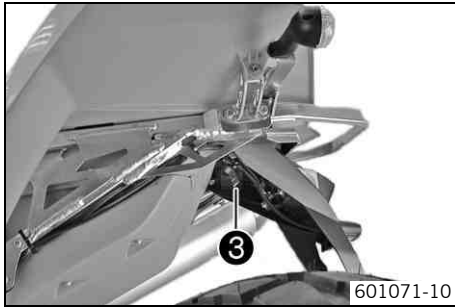

- Push down the rear of the seat until release hook ③ engages.
- Make sure that the seat is correctly locked in.

## Removing the air filter

### Note

**Engine failure** Unfiltered intake air has a negative effect on the service life of the engine.

- Never ride the vehicle without an air filter since dust and dirt can get into the engine and result in increased wear.



### Warning

**Environmental hazard** Hazardous substances cause environmental damage.

- Oil, grease, filters, fuel, cleaners, brake fluid, etc., should be disposed of as stipulated in applicable regulations.

- Remove the seat ( p. 97)

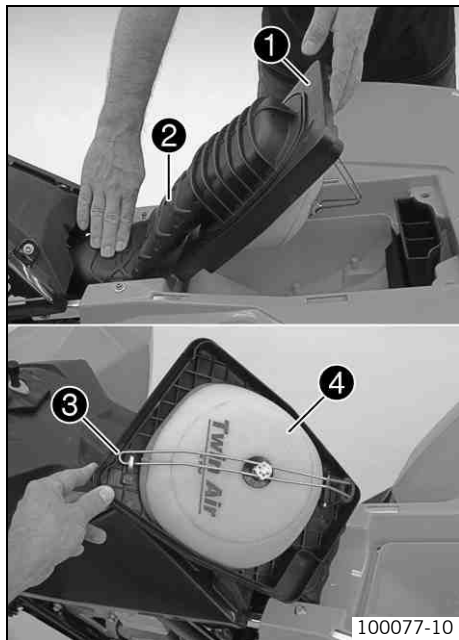

- Raise the rear of the air filter box lid ❶. At the same time, use your other hand to press on the carburetor connection boot ❷ to kink it at that location.

---

**i** Info

This prevents the carburetor connection boot from disconnecting from the carburetor.

- 
- Unhook the air filter holder ❸ and swing it to the side. Remove the air filter ❹ with the air filter support.
  - Remove the air filter from the air filter support.

## Installing the air filter

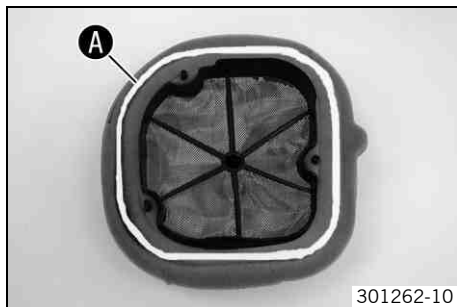

- Mount the clean air filter onto the air filter support.
- Grease the air filter in area **A**.

Long-life grease ( p. 211)

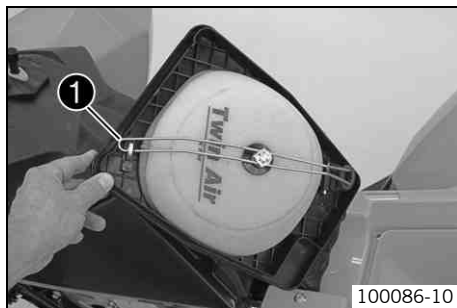

- Put in both parts together, position them and fix them with the air filter support **1**.

### **Info**

If the air filter is not correctly mounted, dust and dirt can penetrate into the engine and can cause damage.

- Mount the air filter box lid.

### **Info**

If the air filter box lid is not correctly mounted, dust and dirt can penetrate into the engine and cause damage.

- Mount the seat. ( p. 97)

## Cleaning the air filter and air filter box



### Warning



**Environmental hazard** Hazardous substances cause environmental damage.

- Oil, grease, filters, fuel, cleaners, brake fluid, etc., should be disposed of as stipulated in applicable regulations.



### Info

Do not clean the air filter with fuel or petroleum since these substances attack the foam.

- Remove the air filter.  ( p. 98)
- Wash the air filter thoroughly in special cleaning liquid and allow it to dry properly.

Air filter cleaner ( p. 210)





### Info

Only press the air filter to dry it; never wring it out.

- Oil the dry air filter with a high/quality filter oil.

Oil for foam air filter ( p. 211)

- Clean the air filter box.
- Check carburetor connection boot for damage and tightness.
- Install the air filter.  ( p. 100)

## Removing the fuel tank



### Danger

**Fire hazard** Fuel is highly flammable.



- Never refuel the vehicle near open flames or burning cigarettes, and always switch off the engine first. Be careful that no fuel is spilt, especially on hot vehicle components. Clean up spilt fuel immediately.
- Fuel in the fuel tank expands when warm and can escape if the tank is overfilled. See the notes on refueling.



### Warning

**Danger of poisoning** Fuel is poisonous and a health hazard.

- Avoid contact between fuel and skin, eyes and clothing. Do not inhale fuel vapors. If fuel gets into your eyes, rinse immediately with water and contact a doctor. Wash affected skin areas immediately with soap and water. If fuel is swallowed, contact a doctor immediately. Change clothing that has come into contact with fuel. Store fuel in a suitable canister according to regulations and keep it out of the reach of children.

- Remove the front trim. ( p. 104)
- Remove the radiator spoiler. ( p. 90)
- Turn the handle **1** of the fuel tap to **OFF**. (Figure 100013-10  p. 42)
- Undo hose clip **2**.
- Pull off fuel hose **3**.



### Info

Remaining fuel may run out of the fuel hose.

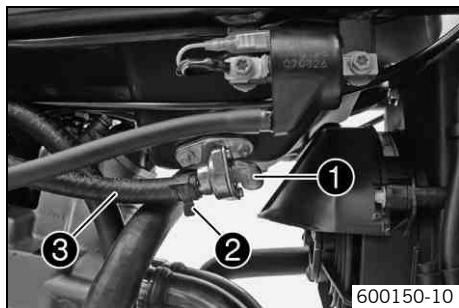



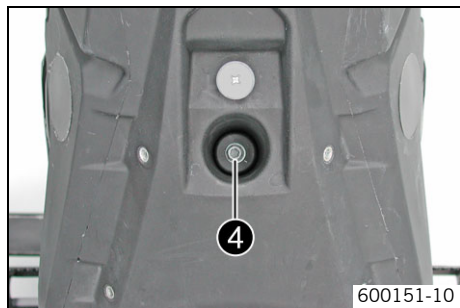

- Remove screw ④ and take off the fuel tank.

## Installing the fuel tank



### Danger

**Fire hazard** Fuel is highly flammable.

- Never refuel the vehicle near open flames or burning cigarettes, and always switch off the engine first. Be careful that no fuel is spilled, especially on hot vehicle components. Clean up spilled fuel immediately.
- Fuel in the fuel tank expands when warm and can escape if the tank is overfilled. See the notes on refueling.



### Warning

**Danger of poisoning** Fuel is poisonous and a health hazard.

- Avoid contact between fuel and skin, eyes and clothing. Do not inhale fuel vapors. If fuel gets into your eyes, rinse immediately with water and contact a doctor. Wash affected skin areas immediately with soap and water. If fuel is swallowed, contact a doctor immediately. Change clothing that has come into contact with fuel. Store fuel in a suitable canister according to regulations and keep it out of the reach of children.

- Check the throttle cable routing. ( p. 123)

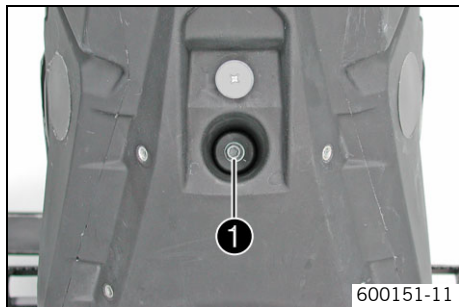

- Position the fuel tank. Mount and tighten screw ❶ with the bushing.

Guideline

Remaining screws, chassis	M6	10 Nm (7.4 lbf ft)
---------------------------	----	--------------------

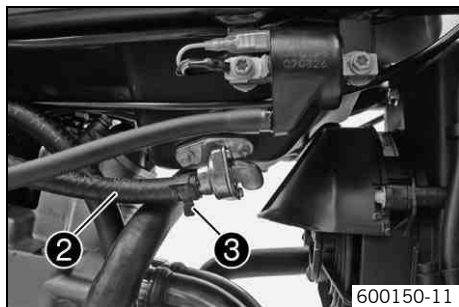

- Connect fuel hose ❷.
- Position hose clip ❸.
- Install the radiator spoiler. (☛ p. 91)
- Install the front trim. (☛ p. 106)

## Removing the front trim

- Remove the front cover. (☛ p. 93)

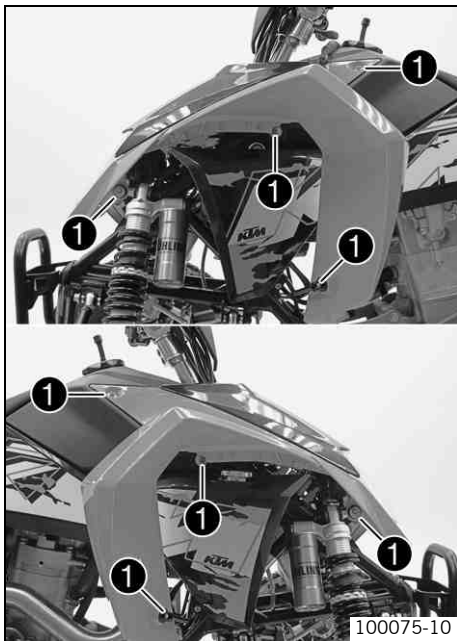

- Remove screws ❶.
- Raise the front trim and disconnect the plug-in connectors from the head light and the emergency OFF switch with the rip cord.
- Remove the front trim.

## Installing the front trim

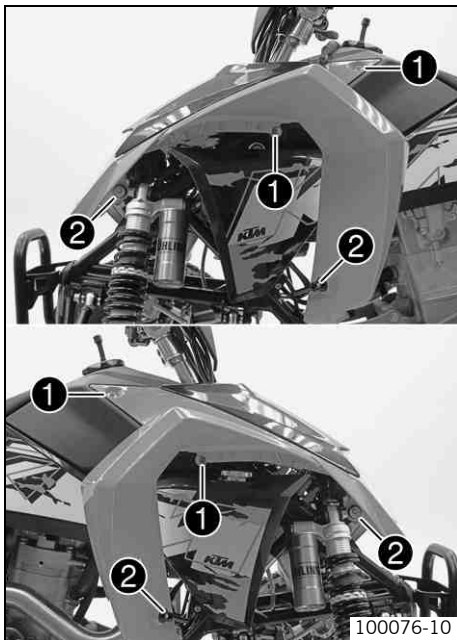

- Connect the plug-in connectors of the head light and the emergency OFF switch with the rip cord and position the front trim.
- Mount all screws.
- Fully tighten screws ❶.

### Guideline

Screw on fuel tank	M6	6 Nm (4.4 lbf ft)
--------------------	----	-------------------

- Fully tighten screws ❷.

### Guideline

Remaining screws, chassis	M6	10 Nm (7.4 lbf ft)
---------------------------	----	--------------------

- Install the front cover. (☛ p. 93)

## Checking the toe ☛

- Park the vehicle on a horizontal surface.
- Check the tire condition. (☛ p. 147)
- Check the tire air pressure. (☛ p. 148)
- Check the chassis parts for damage, play and wear.

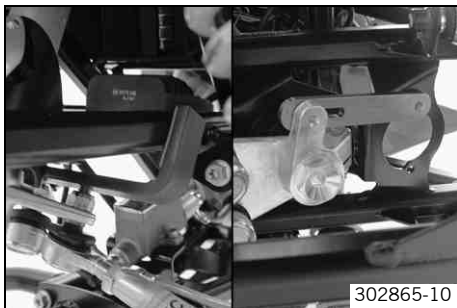

- Load the vehicle with the specified weight.

Guideline

Average rider weight	70... 80 kg (154... 176 lb.)
----------------------	------------------------------

- Move the handlebar into the straight-ahead position and fix it.

Handlebar fixation for straight-ahead position (83019015100)
--

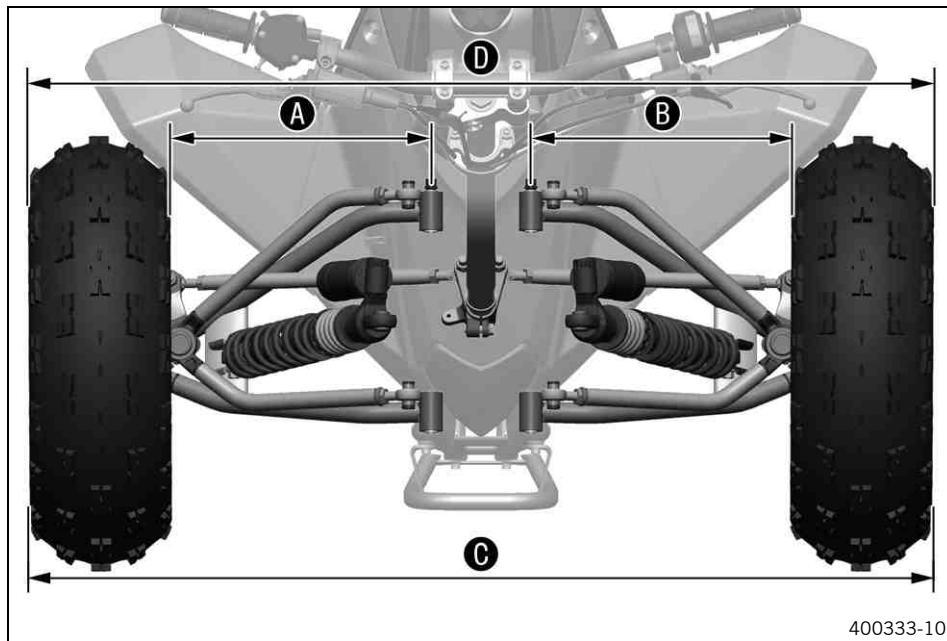

- Measure distances **A** and **B**.
  - » If distances **A** and **B** are not equal:
    - Adjust the toe. 🛠️ (📄 p. 109)
- Measure distances **C** and **D**.

Guideline

Toe	
Front	0 mm (0 in)

## **i** Info

The toe is the difference in length between distances ① and ② by which the wheels are spaced at the front or rear when driving straight ahead. The distance is measured at the height of the wheel center from rim flange to rim flange.

- » If the toe does not meet specifications:
  - Adjust the toe. 🛠️ (👉 p. 109)

## Adjusting the toe 🛠️

- Park the vehicle on a horizontal surface.
- Check the tire condition. (👉 p. 147)
- Check the tire air pressure. (👉 p. 148)
- Check the chassis parts for damage, play and wear. Replace damaged or worn parts.
- Load the vehicle with the specified weight.

### Guideline

Average rider weight	70... 80 kg (154... 176 lb.)
----------------------	------------------------------

- Move the handlebar into the straight-ahead position and fix it.

Handlebar fixation for straight-ahead position (83019015100)
--

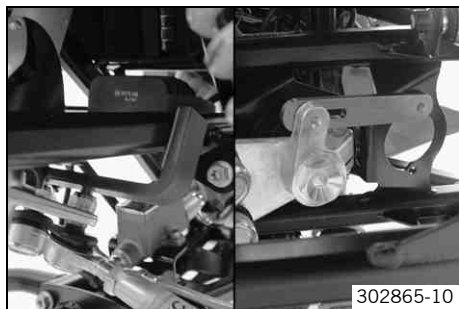

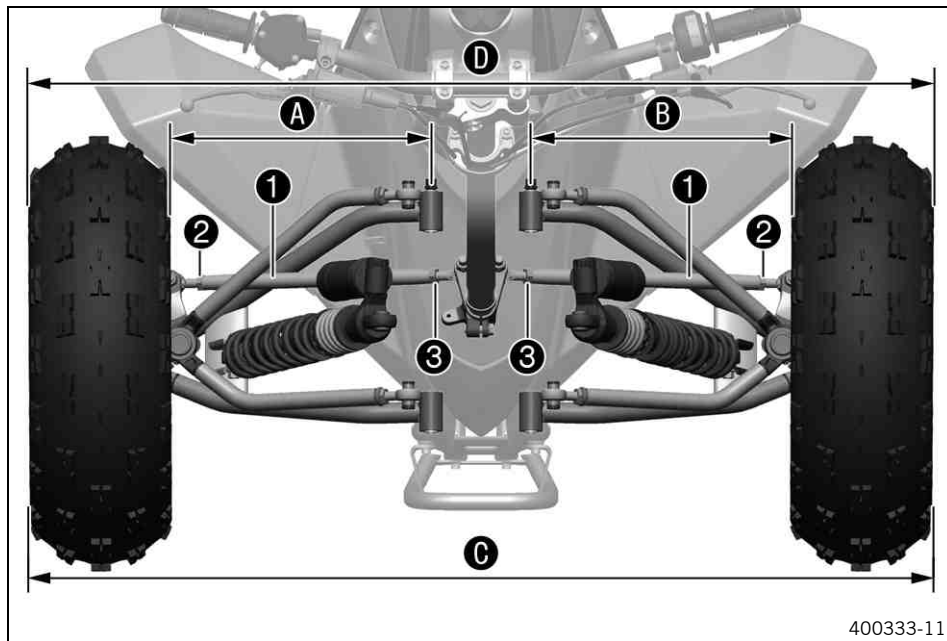

400333-11

- Loosen nuts ② and ③.
- Adjust the distances ① and ② to the same value by rotating the tie rods ①.
- Adjust the distances ③ and ④ to the specified value by evenly rotating the tie rods ①.

Guideline

Toe	
Front	0 mm (0 in)



**Info**

The toe is the difference in length between distances ① and ② by which the wheels are spaced at the front or rear when driving straight ahead. The distance is measured at the height of the wheel center from rim flange to rim flange.

- Tighten nuts ② and ③.

## Guideline

Lock nut, tie rod, outside	M12x1.25	20 Nm (14.8 lbf ft)
Lock nut, tie rod, inside	M12LHx1.25	20 Nm (14.8 lbf ft)

**Info**

The tie rods ① must still be freely movable.

## Checking/adjusting the camber

**Info**

The left and right camber should have the same settings.  
The operations are the same on the left and right.

- Raise the vehicle with the lifting gear. ( p. 88)



- Loosen nuts **1**.

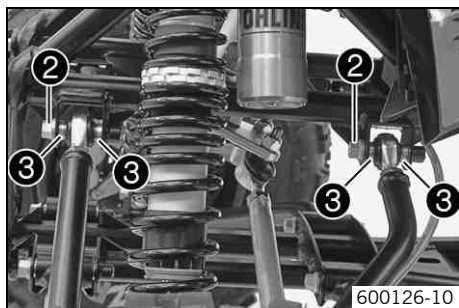

- Remove screws **2** with bushings **3**.

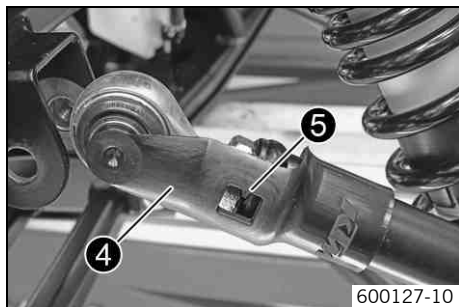

- Insert tool **4** in the heim joint and clip onto the A-arm.

Camber gauge (83019014000)

- Check the camber on both heim joints.
  - » If marking **5** is not aligned with the top edge of the A-arm:
    - Turn tool **4** with the heim joint in steps of 180° until the marking is in line with the top edge of the A-arm.
- Remove tool **4**.

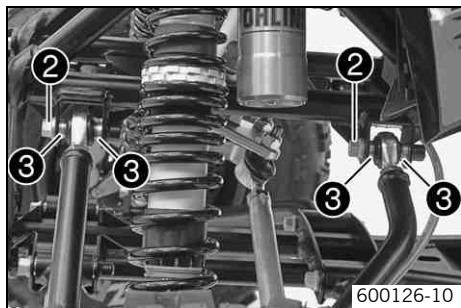

- Position the A-arm with bushings ③. Mount and tighten screws ②.

Guideline

Screw, A-arm top	M10x52	45 Nm (33.2 lbf ft)
------------------	--------	------------------------



- Align the heim joint at right angles to screws ② and tighten nut ①.

Guideline

Nut, A-arm top	M12x1.25	30 Nm (22.1 lbf ft)
----------------	----------	------------------------

**i** Info

All four heim joints must be checked and adjusted if necessary.

- Remove the vehicle from the lifting gear. (🔧 p. 88)

## Checking chain dirt

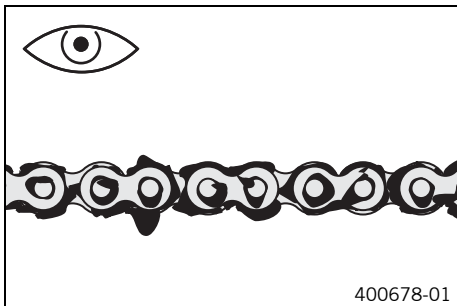

- Check the chain for heavy soiling.
  - » If the chain is very dirty:
    - Clean the chain. (☛ p. 114)

## Cleaning the chain



### Warning

**Environmental hazard** Hazardous substances cause environmental damage.

- Oil, grease, filters, fuel, cleaners, brake fluid, etc., should be disposed of as stipulated in applicable regulations.



### Info

The service life of the chain depends largely on its maintenance.

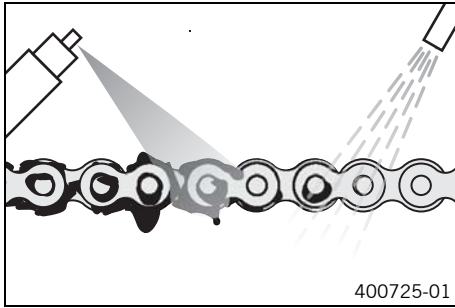

- Clean the chain regularly and then treat with chain spray.

Chain cleaner (☛ p. 210)
Chain lube for road use (☛ p. 210)

## Checking the chain tension



### Warning

**Danger of accidents** Danger caused by incorrect chain tension.

- If the chain tension is too high, the components of the secondary power train (chain, engine sprocket, rear sprocket, bearings in transmission and rear wheel eccentric element) are under additional load. Apart from premature wear, in extreme transmission output shaft or the drive chain may snap. Conversely, if the chain is too loose it may jump off the engine and rear sprockets, causing the rear wheel to lock up or even leading to engine damage. Check for correct chain tension and adjust if necessary.

- Park the vehicle on a horizontal surface and shift gears to neutral.

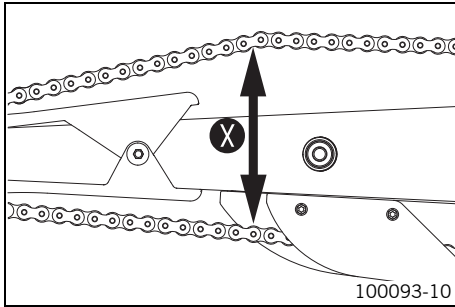

- Push the upper chain section at the end of the chain sliding component upwards to measure the chain tension (X).

## **i** Info

The lower chain section must be taut.

Chain wear is not always even, so you should repeat this measurement at different chain positions.

Chain tension	140... 145 mm (5.51... 5.71 in)
---------------	---------------------------------

- » If the chain tension does not meet specifications:
  - Adjust the chain tension. (🔧 p. 116)

## Adjusting chain tension



### Warning

**Danger of accidents** Danger caused by incorrect chain tension.

- If the chain tension is too high, the components of the secondary power train (chain, engine sprocket, rear sprocket, bearings in transmission and rear wheel eccentric element) are under additional load. Apart from premature wear, in extreme transmission output shaft or the drive chain may snap. Conversely, if the chain is too loose it may jump off the engine and rear sprockets, causing the rear wheel to lock up or even leading to engine damage. Check for correct chain tension and adjust if necessary.

- Check the chain tension. (🔧 p. 115)

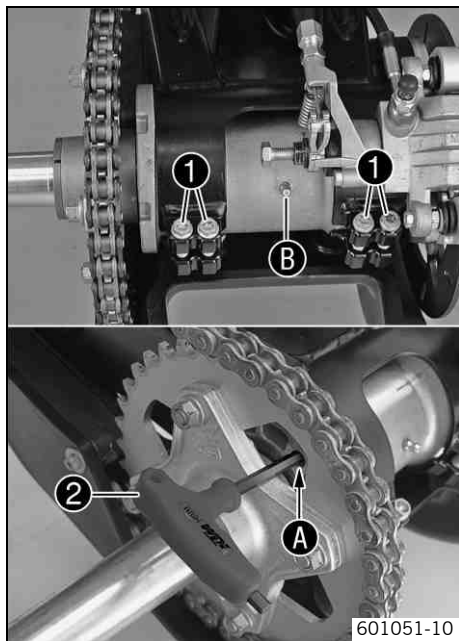

- Loosen the screws ❶ by four turns.

### Alternative 1

- Insert the tool ❷ from the tool set into the hole ❶ of the rear wheel eccentric element.

### Alternative 2

- Position the special tool at the rear wheel eccentric element.

Hook wrench (83019011000)
---------------------------

- To adjust the chain tension, slowly turn the element at the rear wheel or using the special tool to rotate the rear wheel eccentric element forward or backward.

### Guideline

Chain tension	140... 145 mm (5.51... 5.71 in)
---------------	---------------------------------

### **i** Info

Rotating the rear wheel eccentric element forward increases chain tension. Rotating the rear wheel eccentric element backward reduces chain tension. The rear wheel eccentric element should always be positioned such that the grease nipple ❷ is visible. This ensures that the vehicle has the greatest ground clearance.

- Remove the tool.
- Fully tighten screws ❶.

### Guideline

Screw, rear wheel eccentric element	M8	20 Nm (14.8 lbf ft)
-------------------------------------	----	------------------------

## Checking the chain, rear sprocket, engine sprocket, and chain guide

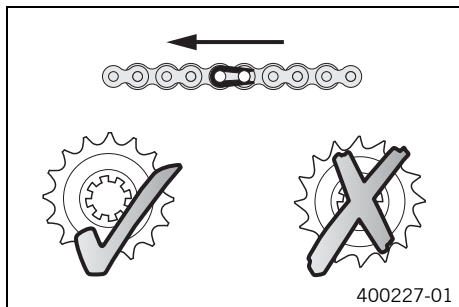

- Shift gear to neutral.
- Check the rear sprocket and engine sprocket for wear.
  - » If the rear sprocket and engine sprocket are worn:
    - Change the rear sprocket or engine sprocket. 



### Info

The engine sprocket, rear sprocket, and chain should always be replaced together.



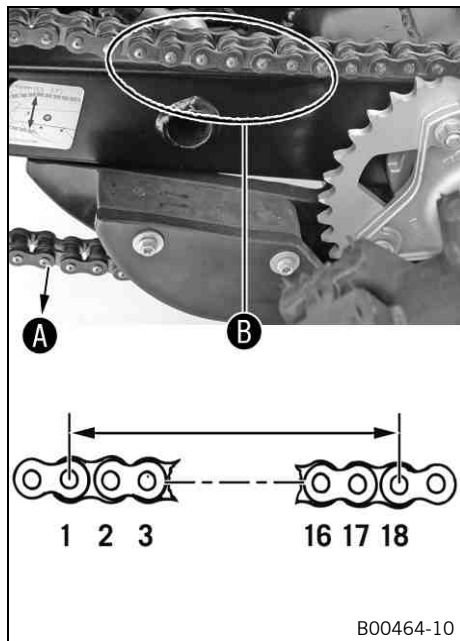

- Pull on the lower part of the chain with the specified weight **A**.

Guideline

Chain-wear measuring weight	10... 15 kg (22... 33 lb.)
-----------------------------	----------------------------

- Measure the distance **B** of 18 chain links in the upper chain section.

**i** **Info**

Chain wear is not always even, so you should repeat this measurement at different chain positions.

Maximum distance <b>B</b> at the longest chain section	272 mm (10.71 in)
--	-------------------

- » If the distance **B** is greater than the specified measurement:

- Replace the chain.

**i** **Info**

When you replace the chain, you should also change the rear sprocket and engine sprocket.

New chains wear out faster on old, worn sprockets.

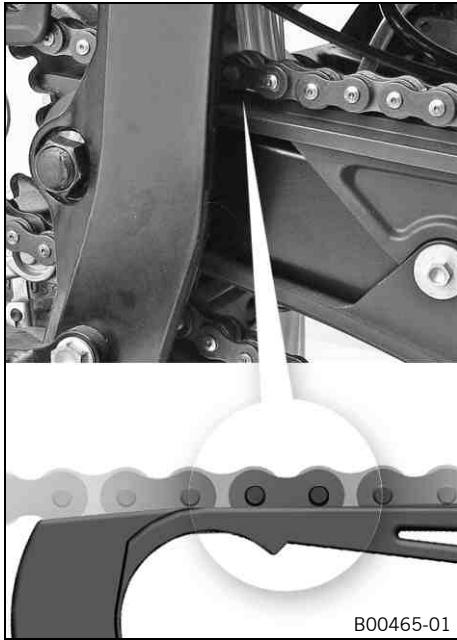

- Check the chain sliding guard at the top for wear.
  - » If the lower edge of the chain pins is in line with or below the chain sliding guard:
    - Change the chain sliding guard. 🛠️

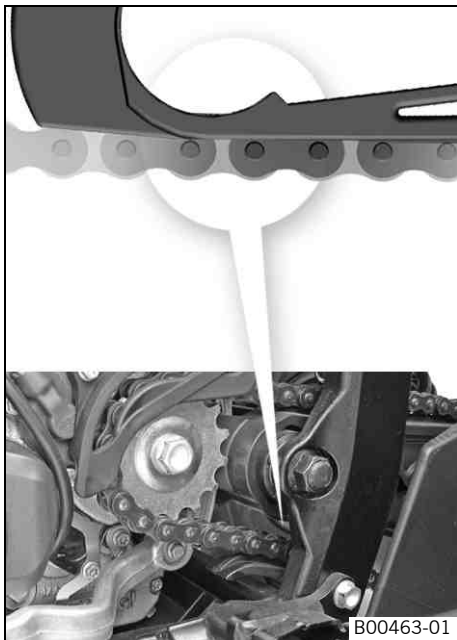

B00463-01

- Check the chain sliding guard at the bottom for wear.
  - » If the lower edge of the chain pins is in line with or below the chain sliding guard:
    - Change the chain sliding guard. 🛠️
- Check the chain sliding guard for tightness.
  - » If the chain sliding guard is loose:
    - Tighten the chain sliding guard.

#### Guideline

Remaining screws, chassis	M6	10 Nm (7.4 lbf ft)
---------------------------	----	-----------------------



- Check the chain sliding piece for wear.
  - » If the lower edge of the chain pins is in line with or below the chain sliding piece:
    - Change the chain sliding piece. 
- Check the chain sliding piece for tightness.
  - » If the chain sliding piece is loose:
    - Tighten the chain sliding piece.

#### Guideline

Screw, chain sliding piece	M8	15 Nm (11.1 lbf ft)
----------------------------	----	------------------------

## Greasing the rear wheel eccentric element

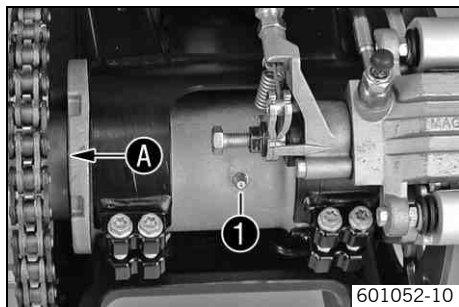

- Use a grease gun to fill the rear wheel eccentric element via the grease nipple ❶ until grease emerges from the left shaft seal ring ❷.

Long-life grease (☛ p. 209)

## Checking the throttle cable routing

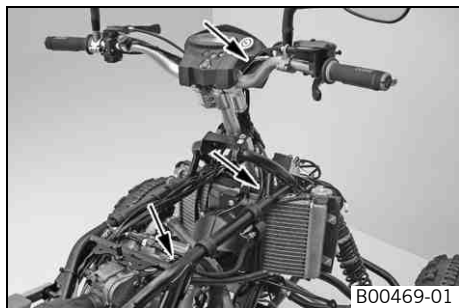

- Remove the fuel tank. ☛ (☛ p. 102)
- Check the throttle cable routing.

The throttle cable must be routed along the front of the handlebar, through the cable guide on the steering column and along the upper frame tube to the carburetor.

- » If the throttle cable is not routed as specified:
  - Correct the throttle cable routing.
- Install the fuel tank. ☛ (☛ p. 103)

## Adjusting basic position of clutch lever

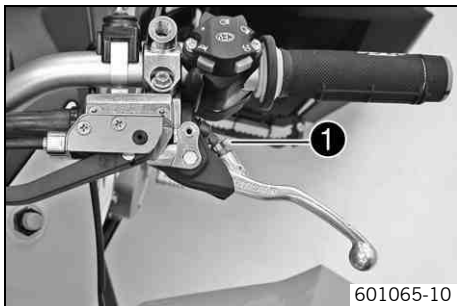

- Adjust the basic setting of the clutch lever to your hand size by turning adjusting screw ❶.

### **i** Info

Turn the adjusting screw counterclockwise to increase the distance between the clutch lever and the handlebar.

Turn the adjusting screw clockwise to decrease the distance between the clutch lever and the handlebar.

The range of adjustment is limited.

Turn the adjusting screw by hand only, and do not apply any force.

Do not make any adjustments while riding!

## Checking fluid level of hydraulic clutch

### **i** Info

The fluid level rises with increasing wear of the clutch lining disc.

Do not use brake fluid.

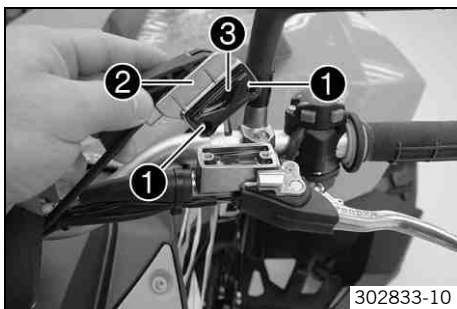

- Move the clutch fluid reservoir mounted on the handlebar to a horizontal position.
- Remove screws ❶.
- Remove cover ❷ with membrane ❸.
- Check the fluid level.

Fluid level under top level of container	4 mm (0.16 in)
--	----------------

- » If the coolant level does not meet specifications:
  - Correct the fluid level of the hydraulic clutch.

Hydraulic fluid (15) (☛ p. 209)
---------------------------------

- Position the cover with the membrane. Mount and tighten screws.

## Removing the engine guard

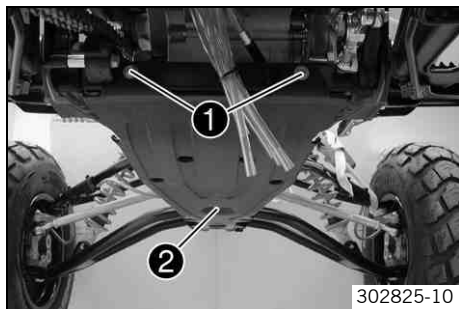

- Remove screws ① and ②. Remove the engine guard.

## Installing the engine guard

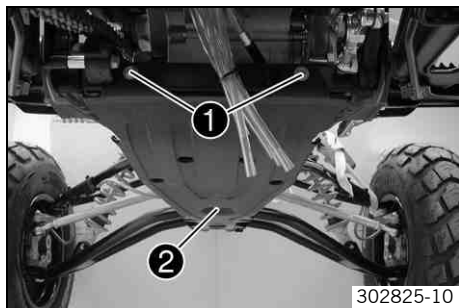

- Position the engine guard on the frame bearer. Mount and tighten screws ① and ②.

### Guideline

Remaining screws, chassis	M6	10 Nm (7.4 lbf ft)
Remaining screws, chassis	M8	25 Nm (18.4 lbf ft)

## Checking the free travel of the hand brake lever



### Warning

**Danger of accidents** Brake system failure.

- If there is no free travel on the hand brake lever, pressure builds up in the front brake circuit. The front brake can fail due to overheating. Adjust free travel on hand brake lever according to specifications.

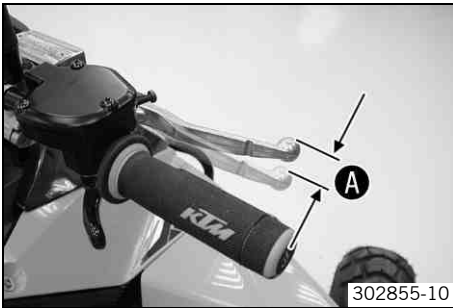

- Push the hand brake lever forward and check free travel **A**.

Free travel of hand brake lever	$\geq 3 \text{ mm } (\geq 0.12 \text{ in})$
---------------------------------	---

- » If the free travel does not meet specifications:
  - Adjust the basic position of hand brake lever. (👉 p. 126)

## Adjusting basic position of hand brake lever

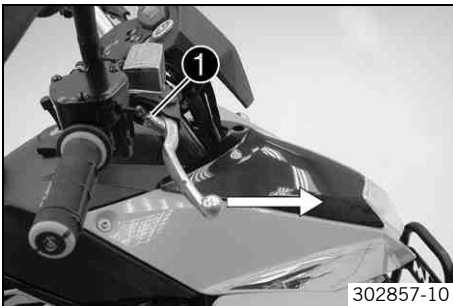

- Check the free travel of the hand brake lever. (👉 p. 126)
- Adjust the basic setting of the hand brake lever to your hand size by turning adjusting screw **1**.



**Info**

Pull the brake lever forward and turn the adjusting screw.  
 Turn the adjusting screw clockwise to increase the distance between the hand brake lever and the handlebar.  
 Turn the adjusting screw counterclockwise to decrease the distance between the hand brake lever and the handlebar.  
 The range of adjustment is limited.  
 Turn the adjusting screw by hand only, and do not apply any force.  
 Do not make any adjustments while riding!

**Checking brake discs****Warning**

**Danger of accidents** Reduced braking efficiency due to worn brake disc(s).

- Change the worn brake disc(s) without delay. (Your authorized KTM workshop will be glad to help.)

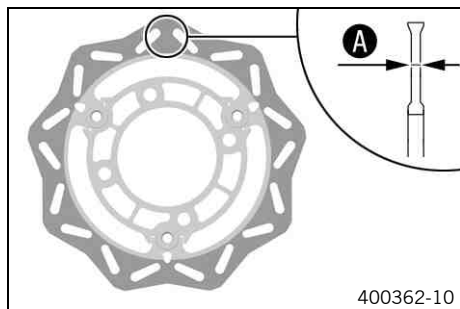

- Check the thickness of the front and rear brake discs at several places on the disc to see if it conforms to measurement **A**.

**Info**

Wear reduces the thickness of the brake disc around the area used by the brake linings.

Brake discs - wear limit	
Front	3.5 mm (0.138 in)
Rear	3.5 mm (0.138 in)

- » If the brake disc thickness is less than the specified value:

- Change the brake disc.
- Check the front and rear brake discs for damage, cracking and deformation.
  - » If the brake disc exhibits damage, cracking or deformation:
    - Change the brake disc.

## Checking front brake fluid level



### Warning

**Danger of accidents** Brake system failure.

- If the brake fluid level falls below the bottom of the viewer, this indicates a leakage in the brake system or worn-out brake linings. Check the brake system and not continue riding. (Your authorized KTM workshop will be glad to help.)



### Warning

**Danger of accidents** Reduced braking effect caused by old brake fluid.

- Change the brake fluid of the front and rear brake according to the service schedule. (Your authorized KTM workshop will be glad to help.)



302858-10

- Move the brake fluid reservoir mounted on the handlebar to a horizontal position.
- Check the brake fluid level in the viewer ❶.
  - » If the brake fluid level drops below the bottom of the viewer:
    - Top up the brake fluid of the front brake. 🛠️ (👉 p. 129)

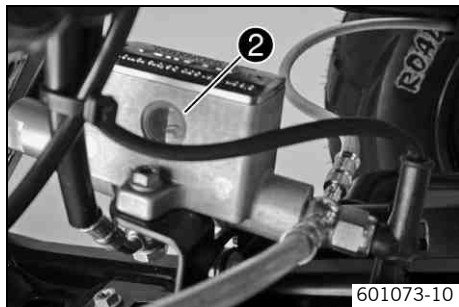

601073-10

- Park the vehicle on a horizontal surface again.
- Check the brake fluid level in the viewer ②.
  - » If the brake fluid level drops below the bottom of the viewer:
    - Top up the brake fluid of the front brake. 🛠️ (👉 p. 129)

### Topping up the front brake fluid 🛠️



#### Warning

**Danger of accidents** Brake system failure.

- If the brake fluid level falls below the bottom of the viewer, this indicates a leakage in the brake system or worn-out brake linings. Check the brake system and not continue riding. (Your authorized KTM workshop will be glad to help.)



#### Warning

**Skin irritation** Brake fluid can cause skin irritation on contact.

- Avoid contact with skin and eyes, and keep out of the reach of children.
- Wear suitable protective clothing and goggles.
- If brake fluid comes into contact with the eyes, flush the eyes thoroughly with water and consult a physician immediately.



#### Warning

**Danger of accidents** Reduced braking effect caused by old brake fluid.

- Change the brake fluid of the front and rear brake according to the service schedule. (Your authorized KTM workshop will be glad to help.)



## Warning

**Environmental hazard** Hazardous substances cause environmental damage.

- Oil, grease, filters, fuel, cleaners, brake fluid, etc., should be disposed of as stipulated in applicable regulations.
- 



## Info

Never use DOT 5 brake fluid! It is silicone-based and purple in color. Oil seals and brake lines are not designed for DOT 5 brake fluid.

Avoid contact between brake fluid and painted parts. Brake fluid is corrosive!

Use only clean brake fluid from a sealed container.

---

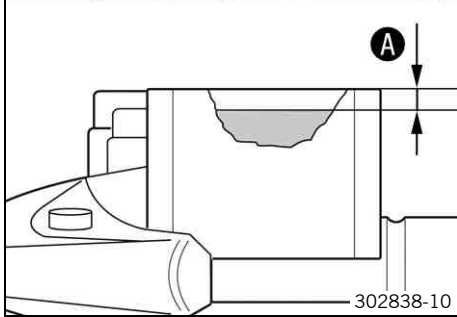
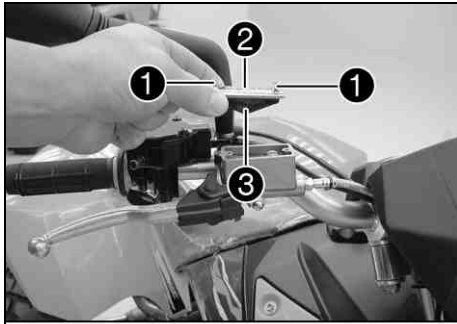

- Move the brake fluid reservoir mounted on the handlebar to a horizontal position.
- Remove screws ①.
- Remove cover ② with membrane ③.
- Add brake fluid to level A.

Guideline

Dimension A (brake fluid level below top edge of container)	5 mm (0.2 in)
---	---------------

Brake fluid DOT 4 / DOT 5.1 (☛ p. 207)

- Position the cover with the membrane. Mount and tighten screws.



**Info**

Clean up overflowed or spilt brake fluid immediately with water.

## Checking the front brake linings



**Warning**

**Danger of accidents** Reduced braking efficiency caused by worn brake linings.

- Change worn brake linings immediately. (Your authorized KTM workshop will be glad to help.)

- Remove the wheel/wheels. (☛ p. 146)

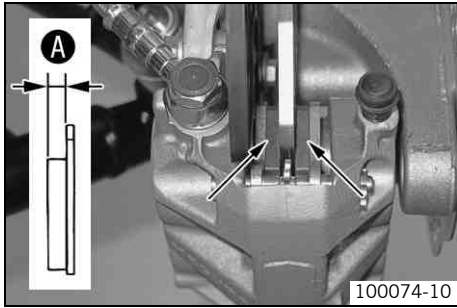

- Check the brake linings of both front brake calipers for minimum thickness **A**.

Minimum thickness <b>A</b>	$\geq 1 \text{ mm } (\geq 0.04 \text{ in})$
----------------------------	---

- » If the minimum thickness is less than specified:
  - Change the front brake linings. 🛠️ (📖 p. 132)
- Check the brake linings for damage and cracking.
  - » If damage or cracking is visible:
    - Change the front brake linings. 🛠️ (📖 p. 132)
- Mount the wheel/wheels. (📖 p. 146)

## Changing the front brake linings 🛠️



### Warning

**Skin irritation** Brake fluid can cause skin irritation on contact.

- Avoid contact with skin and eyes, and keep out of the reach of children.
- Wear suitable protective clothing and goggles.
- If brake fluid comes into contact with the eyes, flush the eyes thoroughly with water and consult a physician immediately.



### Warning

**Danger of accidents** Reduced braking effect caused by old brake fluid.

- Change the brake fluid of the front and rear brake according to the service schedule. (Your authorized KTM workshop will be glad to help.)



### Warning

**Environmental hazard** Hazardous substances cause environmental damage.

- Oil, grease, filters, fuel, cleaners, brake fluid, etc., should be disposed of as stipulated in applicable regulations.

**i Info**

Never use DOT 5 brake fluid! It is silicone-based and purple in color. Oil seals and brake lines are not designed for DOT 5 brake fluid.

Avoid contact between brake fluid and painted parts. Brake fluid is corrosive!

Use only clean brake fluid from a sealed container.

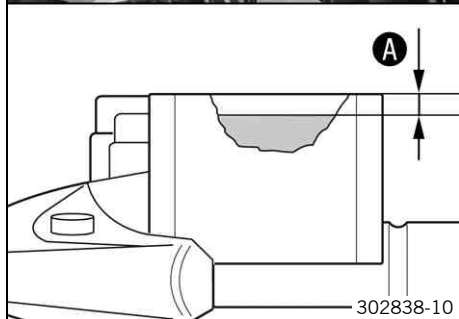
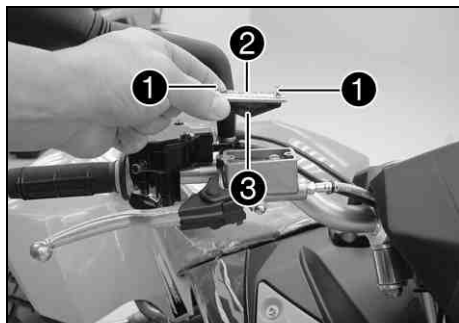

- Remove the front brake linings. 🛠️ (👉 p. 134)
- Move the brake fluid reservoir mounted on the handlebar to a horizontal position.
- Remove screws ❶.
- Remove cover ❷ with membrane ❸.
- Press the brake piston back to its basic position and make sure that no brake fluid overflows from the brake fluid reservoir.
- Mount the front brake linings. 🛠️ (👉 p. 135)
- Correct the brake fluid level to level A.

Guideline

Dimension A (brake fluid level below top edge of container)	5 mm (0.2 in)
---	---------------

Brake fluid DOT 4 / DOT 5.1 (👉 p. 207)

- Position the cover with the membrane. Mount and tighten screws.

**i Info**

Clean up overflowed or spilt brake fluid immediately with water.

## Removing front brake linings



### Warning



**Danger of accident** Brake system failure.

- Maintenance work and repairs must be carried out professionally. (Your authorized KTM workshop will be glad to help.)



### Info

The operations are the same on the left and right.

- Remove the wheel/wheels. ( p. 146)
- Pull the hand brake lever and release it again.
  - ✓ Locking pawl moves into its basic position, parking brake is deactivated.
- Push the brake piston back to release pressure on the brake linings.
- Remove the locking split pins , withdraw the bolt, and take out the brake linings.
- Clean the brake caliper and bolts.

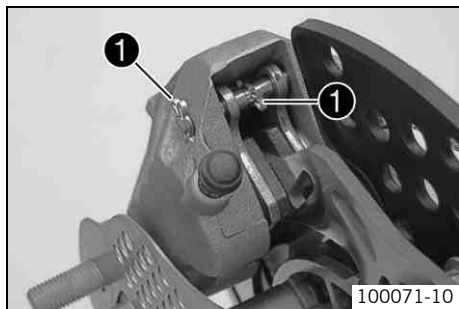



## Mounting front brake linings



### Warning

**Danger of accidents** Reduced braking efficiency due to oil or grease on the brake discs.

- Always keep the brake discs free of oil and grease, and clean them with brake cleaner when necessary.



### Warning

**Danger of accidents** Reduced braking efficiency due to use of non-approved brake linings.

- Brake linings available from accessory suppliers are often not tested and approved for use on KTM vehicles. The construction and friction factor of the brake linings and therefore the brake power can differ considerably from the original KTM brake linings. If brake linings are used that differ from the originals, there is no guarantee that they comply with the original license. The vehicle no longer corresponds to the condition at delivery, and the warranty is no longer valid.



### Info

The operations are the same on the left and right.

- Check the brake discs. ( p. 127)
- Insert the inside brake lining into the brake caliper and fix with bolt **1**.
- Insert the external brake lining into the brake caliper and slide the bolts in all the way.

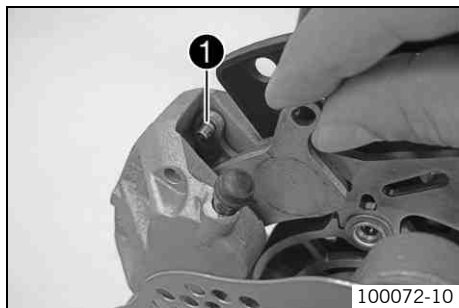

100072-10

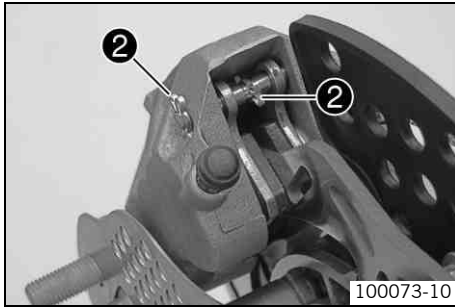

- Mount the locking split pins ②.
- Operate the hand brake lever repeatedly until the brake linings are in contact with the brake disc and there is a pressure point.
- Mount the wheel/wheels. (🔧 p. 146)

## Checking free travel of foot brake lever



### Warning

**Danger of accidents** Brake system failure.

- If there is no free travel on the foot brake lever, pressure builds up on the rear brake circuit. The rear brake can fail due to overheating. Adjust free travel on foot brake lever according to specifications.

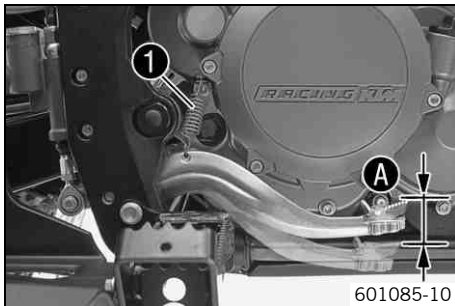

- Disconnect spring ①.
- Move the foot brake lever backwards and forwards between the end stop and the foot brake cylinder piston bracket and check free travel ①.

### Guideline

Free travel at foot brake lever	3... 5 mm (0.12... 0.2 in)
---------------------------------	----------------------------

» If the free travel does not meet specifications:

- Adjust the basic position of the foot brake lever. 🛠️ (🔧 p. 137)
- Reconnect spring ①.

## Adjusting basic position of foot brake lever



### Warning

**Danger of accidents** Brake system failure.

- If there is no free travel on the foot brake lever, pressure builds up on the rear brake circuit. The rear brake can fail due to overheating. Adjust free travel on foot brake lever according to specifications.

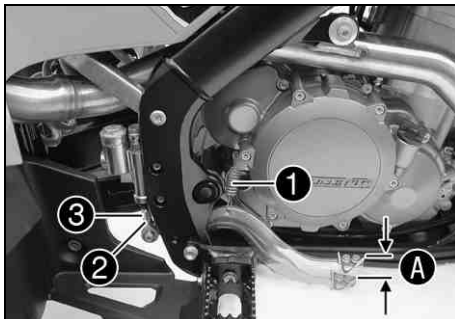

- Disconnect spring ①.
- Loosen nut ② and turn it back with push rod ③ until you have maximum free travel.
- To adjust the basic position of the foot brake lever individually, loosen nut ④ and turn screw ⑤ accordingly.



### Info

The range of adjustment is limited.

- Turn push rod ③ accordingly until you have free travel ④. If necessary, adjust the basic position of the foot brake lever.

#### Guideline

Free travel at foot brake lever	3... 5 mm (0.12... 0.2 in)
---------------------------------	----------------------------

- Hold screw ⑤ and tighten nut ④.

#### Guideline

Remaining nuts, chassis	M8	30 Nm (22.1 lbf ft)
-------------------------	----	------------------------

- Hold push rod ③ and tighten nut ②.

#### Guideline

Remaining nuts, chassis	M6	15 Nm (11.1 lbf ft)
-------------------------	----	------------------------

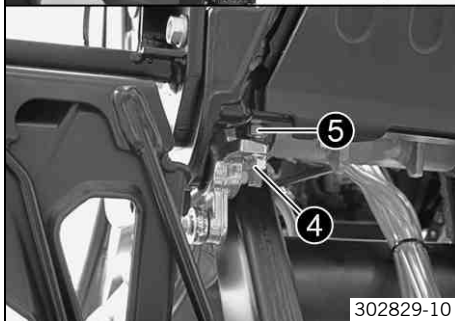

- Reconnect spring ❶.

### Checking rear brake fluid level



#### Warning

**Danger of accidents** Brake system failure.

- If the brake fluid level falls below the bottom of the viewer, this indicates a leakage in the brake system or worn-out brake linings. Check the brake system and not continue riding. (Your authorized KTM workshop will be glad to help.)



#### Warning

**Danger of accidents** Reduced braking effect caused by old brake fluid.

- Change the brake fluid of the front and rear brake according to the service schedule. (Your authorized KTM workshop will be glad to help.)



- Park the vehicle on a horizontal surface.
- Check the brake fluid level in the viewer ❶.
  - » When the brake fluid level has dropped to the bottom of the viewer ❶:
    - Top up the brake fluid of the rear brake. 🛠️ (📄 p. 139)

## Topping up brake fluid of rear brake



### Warning

**Danger of accidents** Brake system failure.

- If the brake fluid level falls below the bottom of the viewer, this indicates a leakage in the brake system or worn-out brake linings. Check the brake system and not continue riding. (Your authorized KTM workshop will be glad to help.)



### Warning

**Skin irritation** Brake fluid can cause skin irritation on contact.

- Avoid contact with skin and eyes, and keep out of the reach of children.
- Wear suitable protective clothing and goggles.
- If brake fluid comes into contact with the eyes, flush the eyes thoroughly with water and consult a physician immediately.



### Warning

**Danger of accidents** Reduced braking effect caused by old brake fluid.

- Change the brake fluid of the front and rear brake according to the service schedule. (Your authorized KTM workshop will be glad to help.)



### Warning

**Environmental hazard** Hazardous substances cause environmental damage.

- Oil, grease, filters, fuel, cleaners, brake fluid, etc., should be disposed of as stipulated in applicable regulations.



### Info

Never use DOT 5 brake fluid! It is silicone-based and purple in color. Oil seals and brake lines are not designed for DOT 5 brake fluid.

Avoid contact between brake fluid and painted parts. Brake fluid is corrosive!

Use only clean brake fluid from a sealed container.

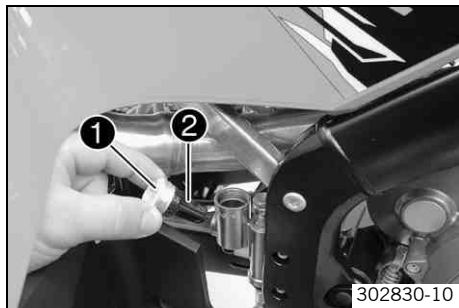

- Remove screw cap ❶ with membrane ❷.



- Add brake fluid to level A.

Brake fluid DOT 4 / DOT 5.1 (👉 p. 207)

- Mount the screw cap with the membrane and tighten.

**i Info**

Clean up overflowed or spilt brake fluid immediately with water.

## Checking rear brake linings



**Warning**

**Danger of accidents** Reduced braking efficiency caused by worn brake linings.

- Change worn brake linings immediately. (Your authorized KTM workshop will be glad to help.)

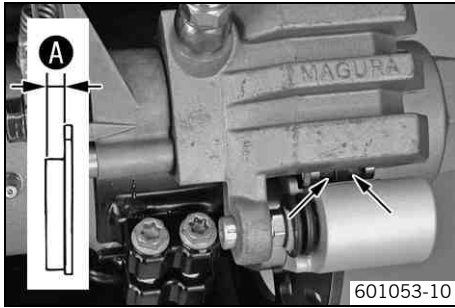

- Check the brake linings for minimum thickness **A**.

Minimum thickness <b>A</b>	$\geq 1 \text{ mm } (\geq 0.04 \text{ in})$
----------------------------	---

- » If the minimum thickness is less than specified:
  - Change the rear brake linings. 🛠️ (📄 p. 141)
- Check the brake linings for damage and cracking.
  - » If damage or cracking is visible:
    - Change the rear brake linings. 🛠️ (📄 p. 141)

## Changing rear brake linings 🛠️



### Warning

**Skin irritation** Brake fluid can cause skin irritation on contact.

- Avoid contact with skin and eyes, and keep out of the reach of children.
- Wear suitable protective clothing and goggles.
- If brake fluid comes into contact with the eyes, flush the eyes thoroughly with water and consult a physician immediately.



### Warning

**Danger of accidents** Reduced braking effect caused by old brake fluid.

- Change the brake fluid of the front and rear brake according to the service schedule. (Your authorized KTM workshop will be glad to help.)



### Warning

**Environmental hazard** Hazardous substances cause environmental damage.

- Oil, grease, filters, fuel, cleaners, brake fluid, etc., should be disposed of as stipulated in applicable regulations.

**i Info**

Never use DOT 5 brake fluid! It is silicone-based and purple in color. Oil seals and brake lines are not designed for DOT 5 brake fluid.

Avoid contact between brake fluid and painted parts. Brake fluid is corrosive!

Use only clean brake fluid from a sealed container.

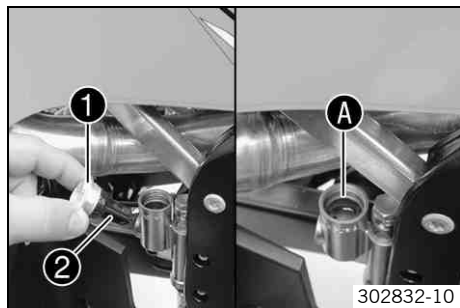

- Remove the rear brake linings. 🗑️ (👉 p. 142)
- Remove screw cap ❶ with membrane ❷.
- Press the brake piston back to its basic position and make sure that no brake fluid overflows from the brake fluid reservoir.
- Mount the rear brake linings. 🗑️ (👉 p. 144)
- Add brake fluid to level A.

Brake fluid DOT 4 / DOT 5.1 (👉 p. 207)

- Mount the screw cap with the membrane and tighten.

**i Info**

Clean up overflowed or spilt brake fluid immediately with water.

## Removing rear brake linings 🗑️

**Warning**

**Danger of accident** Brake system failure.

- Maintenance work and repairs must be carried out professionally. (Your authorized KTM workshop will be glad to help.)



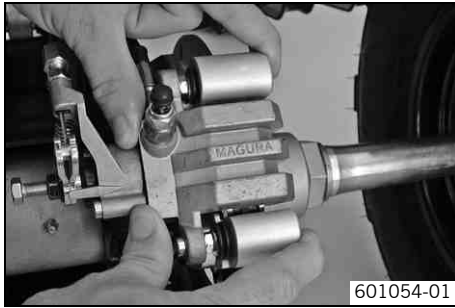

- Press the brake caliper onto the brake disc by hand in order to push back the brake piston.

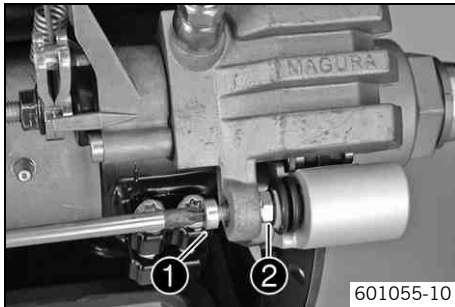

- Loosen the screw ① while holding the hexagonal head ② of the bearing bolt. Unscrew the screw by approx. 10 turns and use the screw to press the bearing bolt out of the brake caliper. Remove screw.

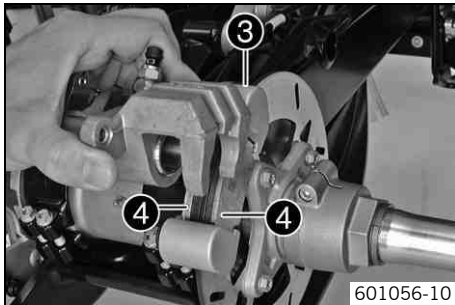

### Note

**Danger of damage** Kinking of brake line.

- Position and handle the brake line without straining it. The brake line must be replaced if it is kinked.
- Swing the brake caliper up, unhook it from the brake caliper support ③ and set it down.
- Remove the brake linings ④.
- Clean brake caliper and brake caliper support.

## Mounting rear brake linings



### Warning

**Danger of accidents** Reduced braking efficiency due to oil or grease on the brake discs.

- Always keep the brake discs free of oil and grease, and clean them with brake cleaner when necessary.



### Warning

**Danger of accidents** Reduced braking efficiency due to use of non-approved brake linings.

- Brake linings available from accessory suppliers are often not tested and approved for use on KTM vehicles. The construction and friction factor of the brake linings and therefore the brake power can differ considerably from the original KTM brake linings. If brake linings are used that differ from the originals, there is no guarantee that they comply with the original license. The vehicle no longer corresponds to the condition at delivery, and the warranty is no longer valid.

- Check the brake discs. ( p. 127)
- Check that the sliding plate **1** is seated correctly in the brake caliper support and insert the brake linings.



### Info

Make sure that the decoupling plate **A** is mounted on the piston side of the brake lining.

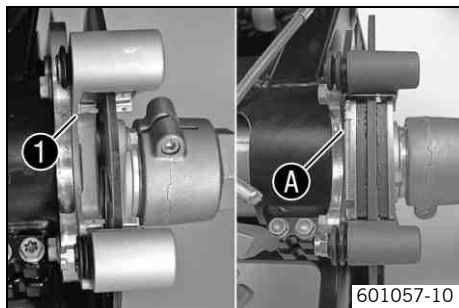

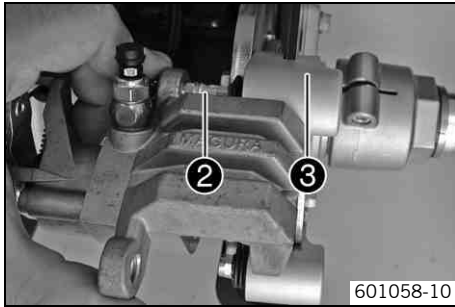

- Grease the bearing bolt ② and insert the brake caliper with the bearing bolt into the brake caliper support ③.

Lubricant (T625) (☛ p. 211)
-----------------------------

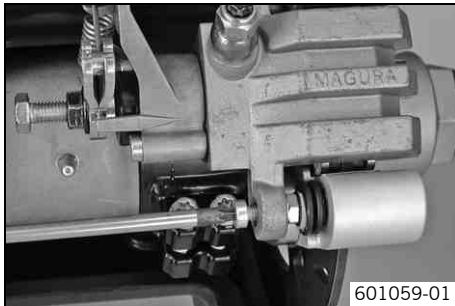

- Swing the brake caliper downward. Mount and tighten the screw.

Guideline

Screw, rear brake caliper	M6	10 Nm (7.4 lbf ft)	<b>Loctite® 243™</b>
---------------------------	----	-----------------------	----------------------

- Operate the foot brake lever repeatedly until the brake linings lie on the brake disc and there is a pressure point.

## Removing wheel/wheels



### Info

Proceed in the same way on the other wheels if necessary.

- Pull the hand brake lever, push the locking pawl ② down and release the hand brake lever. (Figure 302856-10 p. 20)
- Loosen the wheel nuts ①.
- Raise the vehicle with the lifting gear. (p. 88)
- Remove the wheel nuts. Remove the wheel.

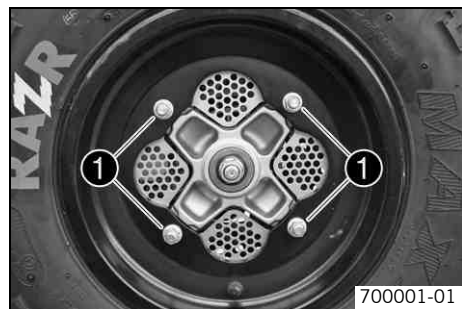

### Info

Carefully remove the wheel, making sure it does not become jammed with the threads of the screws.

## Mounting wheel/wheels

### Note

**Material damage** Damage and destruction of components from incorrect positioning and mounting.

- Do not swap the wheels; the tire valves must always be on the outside when the wheels are positioned and mounted.



### Info

Proceed in the same way on the other wheels if necessary.

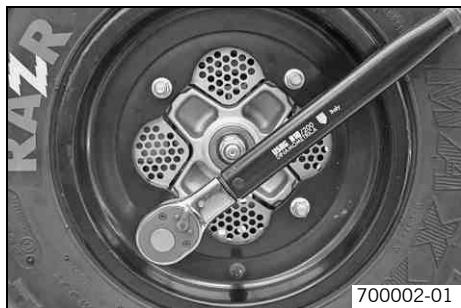

- Position the wheel on the hub.



**Info**

Carefully position the wheel on the hub, being careful not to damage the threads of the screws.

- Mount the wheel nuts but do not tighten yet.

Guideline

Wheel nut	M10x1.25	45 Nm (33.2 lbf ft)
-----------	----------	------------------------

- Remove the vehicle from the lifting gear. (☛ p. 88)
- Pull the hand brake lever, push the locking pawl ② down and release the hand brake lever. (Figure 302856-10☛ p. 20)
- Tighten the wheel nuts crosswise.

Guideline

Wheel nut	M10x1.25	45 Nm (33.2 lbf ft)
-----------	----------	------------------------

## Checking the tire condition



**Info**

Only mount tires that have been approved and/or recommended by KTM.

Other tires could have a negative effect on vehicle handling.

The type, condition and air pressure of the tires all have an important impact on the handling characteristics of the vehicle.

The tires mounted on the front and rear wheels must have similar profiles.

Worn tires have a negative effect on vehicle handling, especially on wet surfaces.

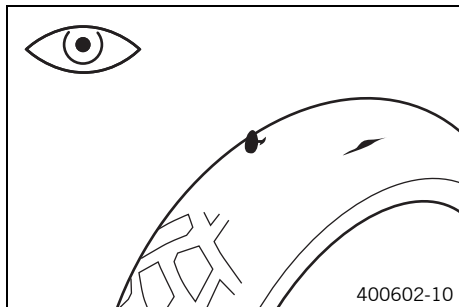

- Check the front and rear tires for cuts, impacted foreign bodies and other damage.
    - » If the tires exhibit cuts, impacted foreign bodies or other damage:
      - Change the tire.
  - Check the depth of the tread.
- |                     |                    |
|---------------------|--------------------|
| Minimum tread depth | ≥ 2 mm (≥ 0.08 in) |
|---------------------|--------------------|
- » If the tread depth is less than the minimum value:
    - Change the tire.
  - Check the tire age.

## **i** Info

The tire's date of manufacture is usually part of the tire markings and is indicated by the last four digits of the **DOT** marking. The first two digits indicate the week of manufacture and the last two digits the year of manufacture. KTM recommends that the tires be changed after 5 years at the latest, regardless of the actual state of wear.

- » If the tire is older than five years:
  - Change the tire.

## Checking the tire air pressure

### **i** Info

Low tire air pressure leads to abnormal wear and overheating of the tire. Correct tire air pressure ensures optimal riding comfort and maximum tire service life. Check the tire pressure on all wheels and correct it if necessary.

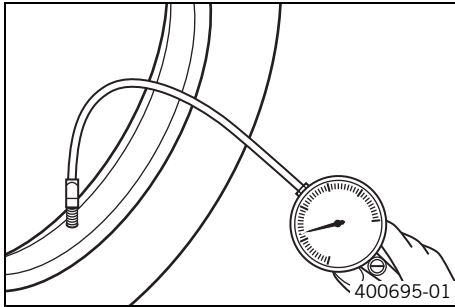

- Remove the dust cap.
- Check the tire air pressure when the tires are cold.

Tire pressure gauge (83519001000)
-----------------------------------

Tire air pressure	1.0 bar (15 psi)
-------------------	------------------

- » If the tire pressure does not meet specifications:
  - Correct the tire pressure.
- Mount the dust cap.

## Removing the battery



### Warning

**Risk of injury** Battery acid and battery gases cause serious cauterization.

- Keep batteries out of the reach of children.
- Wear suitable protective clothing and goggles.
- Avoid contact with battery acid and battery gases.
- Keep the battery away from sparks or open fire. Charge only in well ventilated rooms.
- Flush with copious amounts of water in case of skin contact. If battery acid comes into contact with the eyes, flush the eyes with water for at least 15 minutes and consult a physician.

- Switch off all power consumers and switch off the engine.
- Remove the rear fender. (☛ p. 94)
- Disconnect the negative (minus) cable ❶ of the battery.
- Pull back the plus pole cover and disconnect the positive (plus) cable ❷ of the battery.
- Loosen the rubber band ❸.
- Remove the battery.

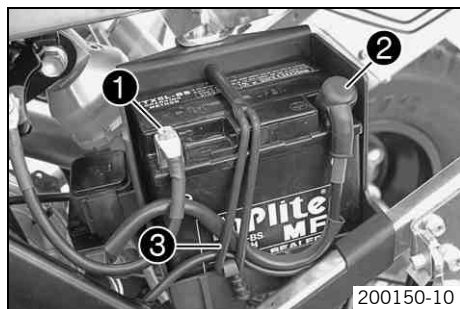



## Installing the battery

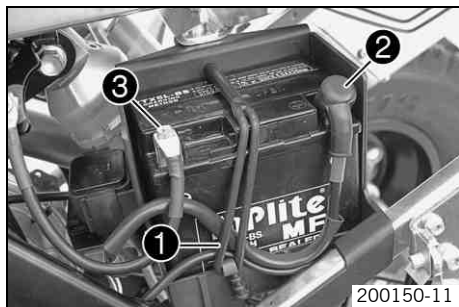

- Place the battery in the battery holder.

Battery (YTX5L-BS) (☛ p. 199)

- Reconnect rubber band ❶.
- Attach the positive (plus) cable and replace the plus pole cover ❷.
- Connect the negative (minus) cable ❸ of the battery.
- Install the rear fender. (☛ p. 95)

## Recharging the battery ☛



### Warning

**Risk of injury** Battery acid and battery gases cause serious cauterization.

- Keep batteries out of the reach of children.
- Wear suitable protective clothing and goggles.
- Avoid contact with battery acid and battery gases.
- Keep the battery away from sparks or open fire. Charge only in well ventilated rooms.
- Flush with copious amounts of water in case of skin contact. If battery acid comes into contact with the eyes, flush the eyes with water for at least 15 minutes and consult a physician.



### Warning

**Environmental hazard** Battery parts and acid are harmful to the environment.

- Do not discard batteries with the household trash. Dispose of a defective battery in an environmentally compatible manner. Give the battery to your KTM dealer or to a recycling center that accepts used batteries.



## Warning

**Environmental hazard** Hazardous substances cause environmental damage.

- Oil, grease, filters, fuel, cleaners, brake fluid, etc., should be disposed of as stipulated in applicable regulations.
- 



## Info

Even if there is no load on the battery, it still loses power steadily.

The charge state and the type of charge are very important for the service life of the battery.

Rapid charging with a high charging current has a negative impact on the service life.

If the charging current, charging voltage and charging time are exceeded, electrolyte escapes via the safety valves. This reduces the battery capacity.

If the vehicle is started repeatedly until the battery is depleted, the battery must be charged immediately.

If the battery is left in a discharged state for an extended period, it will drain completely and sulfate, destroying the battery.

The battery is maintenance-free, which means that the acid level does not need to be checked.

---

- Switch off all power consumers and switch off the engine.
- Remove the rear fender. (☛ p. 94)
- Disconnect the minus (negative) cable of the battery to avoid damage to the vehicle's electronics.



- Connect the battery charger to the battery. Switch on the battery charger.

Battery charger (58429074000)

In addition, this battery charger can be used to test the open-circuit current, the start ability of the battery and the alternator. With this device, you cannot overcharge the battery.

**i** Info

Never remove the lid ❶.

Charge the battery to a maximum of 10% of the capacity specified on the battery housing ❷.

- Switch off the charger after charging. Disconnect the battery.

Guideline

The charge current, charge voltage and charge time must not be exceeded.

Charge the battery regularly when the vehicle is not in use	3 months
---	----------

- Install the rear fender. (👉 p. 95)

## Changing the main fuse

- Switch off all power consumers and the engine.

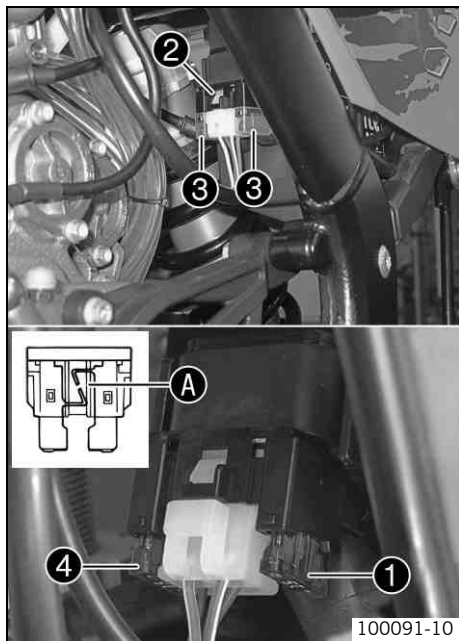

- The main fuse ❶ is located in the starter relay ❷ in front of the battery.
- Remove protection covers ❸.
- Remove the faulty main fuse.

**Info**

You can recognize a blown fuse by its broken filament ❶.

**Warning**

**Fire hazard** The electrical system can be overloaded by the use of incorrect fuses.

- Use only fuses with the prescribed amperage. Never by-pass or repair fuses.

- Insert the new fuse.

Fuse (58011109120)

**Tip**

Replacement fuse ❷ should always be present in the starter relay to make sure it is available when needed.

- Replace the protection covers.

### Changing the fuses of individual power consumers

- Remove the front cover. (☛ p. 93)
- Switch off all power consumers and the engine.

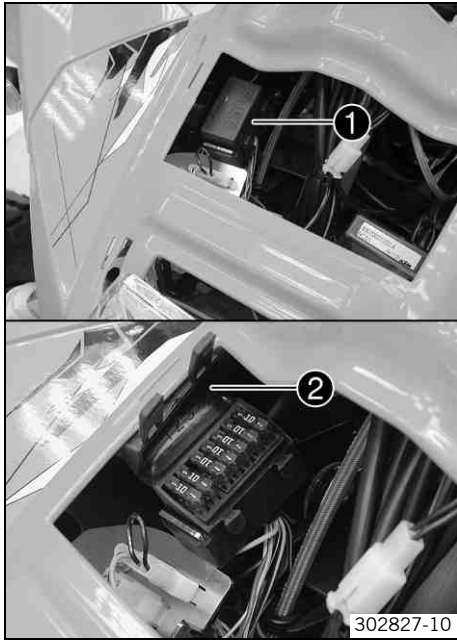

- Open cover ② of fuse box ①.



### Info

The designation of the fuses is located on the inside cover of fuse box ②.

- Remove the faulty fuse.

### Guideline

Fuse - 1 10A - ignition, CDI controller, indicator lamps ON, N, R
---

Fuse - 2 10A - high beam, low beam, parking light, tail light, brake light, high beam indicator lamp
--

Fuse - 3 10A - radiator fan
-----------------------------

Fuse - 4 10A - for auxiliary devices (permanent positive)
---

Fuse 5 10A - for auxiliary devices (plus switched on with ignition switch)
--

Fuse res. - 10A - spare fuses
-------------------------------



### Info

You can recognize a blown fuse by its broken filament ⚠.



### Warning

**Fire hazard** The electrical system can be overloaded by the use of incorrect fuses.

- Use only fuses with the prescribed amperage. Never by-pass or repair fuses.

- Insert a new fuse of the appropriate strength.

Fuse (58011109110)
--------------------

**Tip**

The replacement fuses should always be present in the fuse box to make sure they are available when needed.

- Close the cover of the fuse box.
- Install the front cover. (☛ p. 93)

### Checking the headlight setting

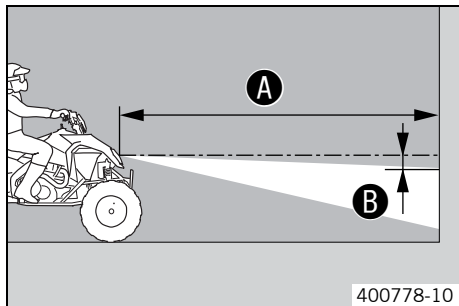

- On a light-colored wall with a horizontal area in front of it, make a mark at the height of the center of the headlight.
- Make another mark a distance **B** under the first mark.

## Guideline

Distance <b>B</b>	5 cm (2 in)
-------------------	-------------

- Position the vehicle a distance **A** vertically in front of the wall.
- Now the rider, wearing a full set of protective clothing, sits on the vehicle in the normal sitting position (feet on the footrests).

## Guideline

Distance <b>A</b>	5 m (16 ft)
-------------------	-------------

- Switch on the low beam. Check the headlight setting.

The boundary between light and dark must be exactly at the lower mark when the vehicle is operational and complete with a rider.

- » If the boundary between light and dark does not meet specifications:
  - Adjust the headlight range of the headlight. (☛ p. 157)

## Adjusting the headlight range of the headlight



- Check the headlight setting. (☛ p. 156)
- Loosen screw ❶.
- Adjust the headlight range of the headlight by moving it up or down.

### Guideline

The boundary between light and dark must be exactly on the lower mark for an operational vehicle with a rider (to prepare the mark, see: Checking the headlight setting).

### **i** Info

A change in weight on the vehicle may require a correction of the headlight range.

- Tighten screw ❶.

## Cooling system

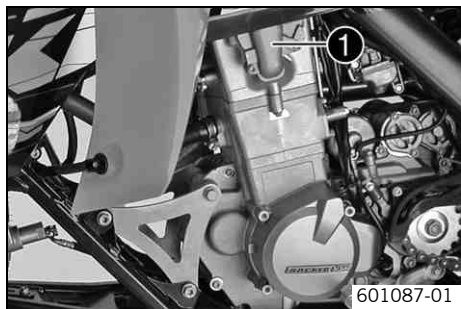

The water pump ❶ in the engine forces the coolant to flow.

The pressure resulting from the warming of the cooling system is regulated by a valve in the radiator cap . This ensures that operating the vehicle at the specified coolant temperature will not result in a risk of malfunctions.

120 °C (248 °F)
-----------------

Cooling is effected by the air stream. The radiator fan provides extra cooling.

The lower the speed, the less the cooling effect. Dirty cooling fins also reduce the cooling effect.

## Radiator fan



The radiator fan ❶ is located on the radiator under the fuel tank.

### Working range within which radiator fan is switched on and off.

Thermoswitch	
Switch-off temperature	80 °C (176 °F)
Switch-on temperature	85 °C (185 °F)



## Checking the antifreeze and coolant level



### Warning

**Danger of scalding** The coolant gets very hot and is under high pressure when the vehicle is operated.

- Do not remove the radiator cap or remove radiator hoses or other cooling system components when the engine is hot. Allow the engine and cooling system to cool down. If you scald yourself, hold the affected area under lukewarm water immediately.



### Warning

**Danger of poisoning** Coolant is poisonous and a health hazard.

- Avoid contact between coolant and skin, eyes and clothing. If it gets into your eyes, rinse immediately with water and contact a doctor. Wash affected skin areas immediately with soap and water. If coolant is swallowed, contact a doctor immediately. Change clothes that have come into contact with coolants. Keep coolant out of the reach of children.

### Condition

The engine is cold.

- Park the vehicle on a horizontal surface.
- Remove the front trim. (☛ p. 104)
- Remove radiator cap ❶.
- Check the coolant antifreeze.

–25... -45 °C (-13... -49 °F)

» If the coolant antifreeze does not meet specifications:

- Correct the coolant antifreeze.

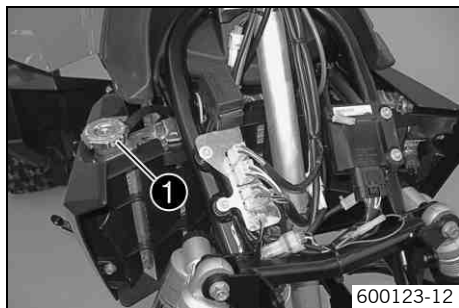

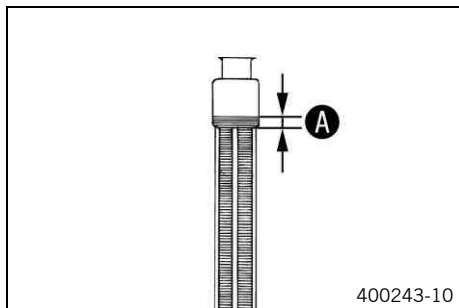

- Check the coolant level in the radiator.

Coolant level <b>A</b> above the radiator fins.	10 mm (0.39 in)
---	-----------------

- » If the coolant level does not meet specifications:

- Correct the coolant level.

### Alternative 1

Coolant (☛ p. 207)
--------------------

### Alternative 2

Coolant (mixed ready to use) (☛ p. 207)
---

- Mount the radiator cap.
- Install the front trim. (☛ p. 106)

## Checking the coolant level



### Warning

**Danger of scalding** The coolant gets very hot and is under high pressure when the vehicle is operated.

- Do not remove the radiator cap or remove radiator hoses or other cooling system components when the engine is hot. Allow the engine and cooling system to cool down. If you scald yourself, hold the affected area under lukewarm water immediately.



### Warning

**Danger of poisoning** Coolant is poisonous and a health hazard.

- Avoid contact between coolant and skin, eyes and clothing. If it gets into your eyes, rinse immediately with water and contact a doctor. Wash affected skin areas immediately with soap and water. If coolant is swallowed, contact a doctor immediately. Change clothes that have come into contact with coolants. Keep coolant out of the reach of children.

### Condition

The engine is cold.

- Park the vehicle on a horizontal surface.
- Remove the front trim. (☞ p. 104)
- Remove the radiator cap.
- Check the coolant level in the radiator.

Coolant level <b>A</b> above the radiator fins.	10 mm (0.39 in)
---	-----------------

- » If the coolant level does not meet specifications:
  - Correct the coolant level.

### Alternative 1

Coolant (☞ p. 207)
--------------------

### Alternative 2

Coolant (mixed ready to use) (☞ p. 207)
---

- Mount the radiator cap.
- Install the front trim. (☞ p. 106)

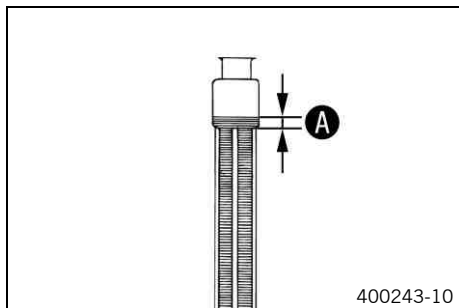

## Draining coolant ☞



### Warning

**Danger of scalding** The coolant gets very hot and is under high pressure when the vehicle is operated.

- Do not remove the radiator cap or remove radiator hoses or other cooling system components when the engine is hot. Allow the engine and cooling system to cool down. If you scald yourself, hold the affected area under lukewarm water immediately.



### Warning

**Danger of poisoning** Coolant is poisonous and a health hazard.

- Avoid contact between coolant and skin, eyes and clothing. If it gets into your eyes, rinse immediately with water and contact a doctor. Wash affected skin areas immediately with soap and water. If coolant is swallowed, contact a doctor immediately. Change clothes that have come into contact with coolants. Keep coolant out of the reach of children.

- Remove the front trim. (☛ p. 104)
- Place a suitable container under the vehicle.
- Remove screw ❶.

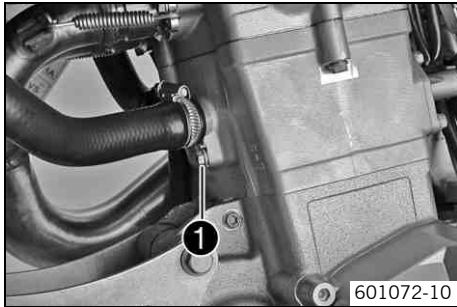

- Remove screw ❷.

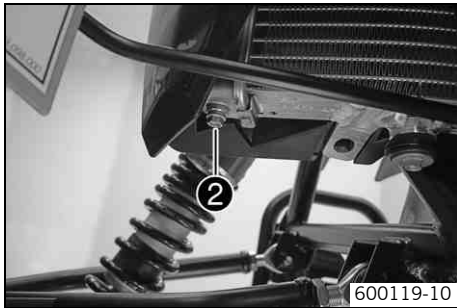

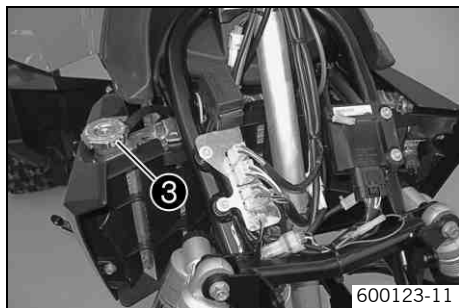

- Remove the radiator cap ③. Completely drain the coolant.

## Filling coolant / bleeding cooling system 🛠️



### Warning

**Danger of poisoning** Coolant is poisonous and a health hazard.

- Avoid contact between coolant and skin, eyes and clothing. If it gets into your eyes, rinse immediately with water and contact a doctor. Wash affected skin areas immediately with soap and water. If coolant is swallowed, contact a doctor immediately. Change clothes that have come into contact with coolants. Keep coolant out of the reach of children.

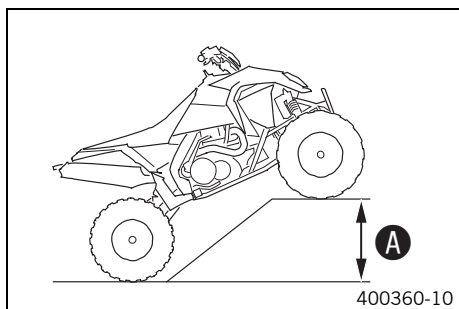

- Position the vehicle as shown and secure it against rolling away. The height difference **A** must be achieved.

### Guideline

Height difference <b>A</b>	50 cm (19.7 in)
----------------------------	-----------------

- Pull the hand brake lever, push the locking pawl ② down and release the hand brake lever. (Figure 302856-10 📖 p. 20)
- ✓ The front wheels are locked.

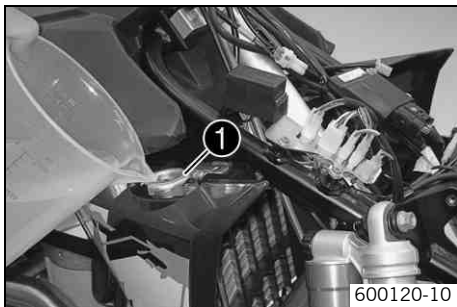

- Fill the coolant into the radiator ❶.

Coolant	1.30 l (1.37 qt.)	Coolant (☛ p. 207)
		Coolant (mixed ready to use) (☛ p. 207)

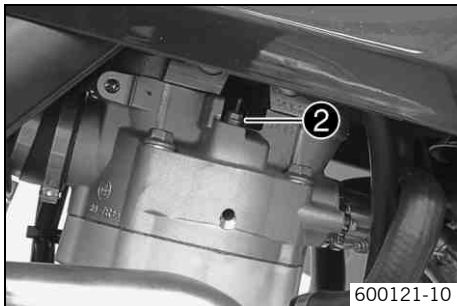

- Open the screw ❷ to bleed the cylinder head. Tighten the screw ❷ when coolant emerges from the opening.

Guideline

Remaining screws, chassis	M6	10 Nm (7.4 lbf ft)
---------------------------	----	--------------------

**i** Info

Ensure that the radiator is always filled with a sufficient amount of coolant.

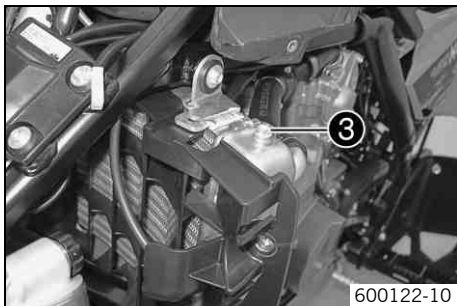

- Open the screw ❸ to bleed the radiator. Tighten the screw ❸ when coolant emerges from the opening.

Guideline

Remaining screws, chassis	M6	10 Nm (7.4 lbf ft)
---------------------------	----	--------------------

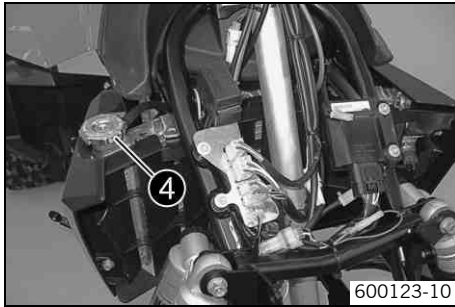

- Completely fill the radiator and close the radiator cap ④.
- Place the vehicle on the ground.
- Install the front trim. (☛ p. 106)
- Make a short test ride.
- Check the coolant level. (☛ p. 160)

## Checking the play in the throttle cable

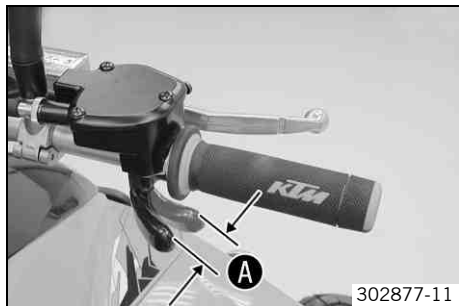

- Move the handlebar to the straight-ahead position. Move the throttle lever back and forth slightly to ascertain the play in the throttle cable **A**.

### Guideline

Play in throttle cable	3... 5 mm (0.12... 0.2 in)
------------------------	----------------------------

- » If the throttle cable play does not meet specifications:
  - Adjust the play in the throttle cable. (☛ p. 166)



### Danger

**Danger of poisoning** Exhaust gases are poisonous and inhaling them may result in unconsciousness and/or death.

- When running the engine, always make sure there is sufficient ventilation, and do not start or run the engine in an enclosed space without an effective exhaust extraction system.
- 
- Start the engine and let it run idle. Move the handlebar to and fro over the entire steering range.

The idle speed must not change.
---------------------------------

- » If the idle speed changes:
  - Adjust the play in the throttle cable. (☛ p. 166)

## Adjusting play in throttle cable

- Check the throttle cable routing. (☛ p. 123)



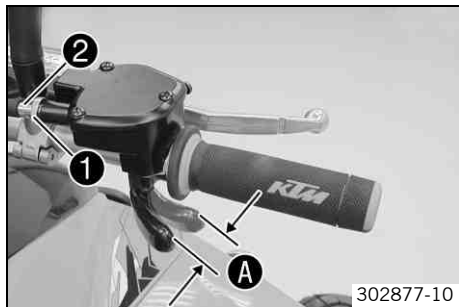

- Move the handlebar to the straight-ahead position.
- Loosen the nut ① and use the screw ② to adjust the play in the throttle cable A.

Guideline

Play in throttle cable	3... 5 mm (0.12... 0.2 in)
------------------------	----------------------------

- Tighten nut ①.

## Carburetor - adjusting idle 🔧

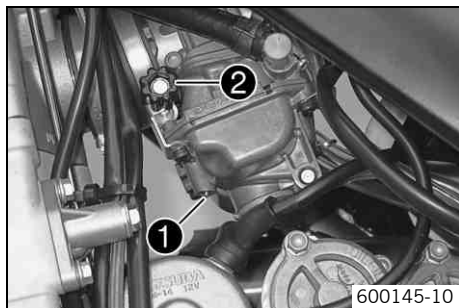

- Screw in the idle adjusting screw ① until it stops and then to the prescribed basic setting.

Guideline

Idle mixture adjusting screw	
Open	1.0 turn

Adjustment tool for mixture control screw (59029034000)	
---	--

- Run the engine until warm.

Guideline

Warm-up time	≥ 5 min
--------------	---------

- Adjust the idle speed with the adjusting screw ②.

Guideline

Choke function deactivated – The choke lever is pushed in to the stop. (🔧 p. 43)	
Idle speed	1,500... 1,600 rpm

**i** **Info**

If the idle speed is set significantly higher, the engine does not start. When the electric starter button is activated, the electric starter turns over the engine, but the engine does not start because there is no ignition spark.

- Turn the idle adjusting screw ❶ slowly until the idle speed begins to fall.
- Note the position and turn the idle adjusting screw slowly counterclockwise until the idle speed falls.
- Adjust to the point between these two positions with the highest idle speed.

**i** **Info**

If there is a big engine speed rise, reduce the idle speed to a normal level and repeat the above steps.

The extremely sporty rider will set the mixture about 1/4 of a turn back from this ideal value (leaner, in a clockwise direction) since the engine becomes hotter in sporting use.

If the procedure described here does not lead to satisfactory results, the cause may be a wrongly dimensioned idling jet.

If you can turn the idle adjusting screw to the end without any change of engine speed, you have to fit a smaller idling jet.

The idle adjusting screw must not be opened more than two turns. If more than two turns are necessary (rich mixture), use a larger idling jet.

After changing the idling jet, start from the beginning with the adjusting steps.

- Adjust the idle speed with the adjusting screw ❷.

Guideline

Choke function deactivated – The choke lever is pushed in to the stop. (☛ p. 43)	
Idle speed	1,500... 1,600 rpm



## Info

Following extreme air temperature or altitude changes, adjust the idle speed again.

## Emptying the carburetor float chamber



### Danger

**Fire hazard** Fuel is highly flammable.

- Never refuel the vehicle near open flames or burning cigarettes, and always switch off the engine first. Be careful that no fuel is spilt, especially on hot vehicle components. Clean up spilt fuel immediately.
- Fuel in the fuel tank expands when warm and can escape if the tank is overfilled. See the notes on refueling.



### Warning

**Danger of poisoning** Fuel is poisonous and a health hazard.

- Avoid contact between fuel and skin, eyes and clothing. Do not inhale fuel vapors. If fuel gets into your eyes, rinse immediately with water and contact a doctor. Wash affected skin areas immediately with soap and water. If fuel is swallowed, contact a doctor immediately. Change clothing that has come into contact with fuel. Store fuel in a suitable canister according to regulations and keep it out of the reach of children.



### Warning



**Environmental hazard** Improper handling of fuel is a danger to the environment.

- Do not allow fuel to get into the ground water, the ground, or the sewage system.



## Info

Carry out this work with a cold engine.

- Turn the handle  of the fuel tap to **OFF**. (Figure 100013-10  p. 42)



✓ No more fuel flows from the tank to the carburetor.

- Guide the hose coming down behind the engine into a suitable container.



### Info

Water in the float chamber results in malfunctioning.

- Undo the screw ❶ (turn it counterclockwise) a few turns and drain the fuel from the float chamber.
- Tighten screw ❶.

## Carburetor - idle

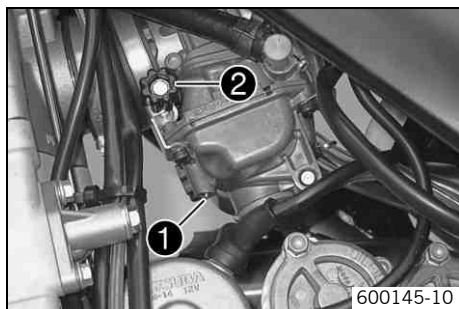

The idle setting of the carburetor has a big influence on the starting behavior, stable idling and the response to throttle opening. That means that an engine with a correctly set idle speed is easier to start than if the idle is set wrongly.



### Info

The carburetor and its components are subject to increased wear caused by engine vibration. Wear can result in malfunctioning.

If the idle speed is set significantly higher, the engine does not start. When the electric starter button is activated, the electric starter turns over the engine, but the engine does not start because there is no ignition spark.

The idle speed is adjusted with the adjustment screw ❷.

The idle mixture is adjusted with the idle mixture adjustment screw ❶.

## Checking the basic setting of the shift lever

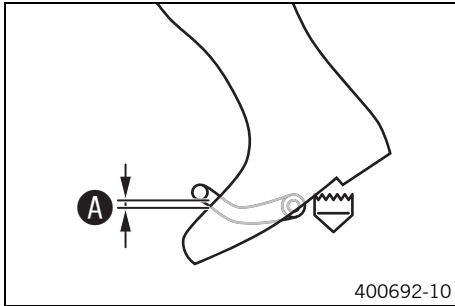

- Sit on the vehicle in the riding position and determine the distance **A** between the upper edge of your boot and the shift lever.

Distance between shift lever and upper edge of boot	10... 20 mm (0.39... 0.79 in)
---	-------------------------------

- » If the distance does not meet specifications:
  - Adjust the basic position of the shift lever. 🛠️ (📄 p. 171)

## Adjusting the basic position of the shift lever 🛠️

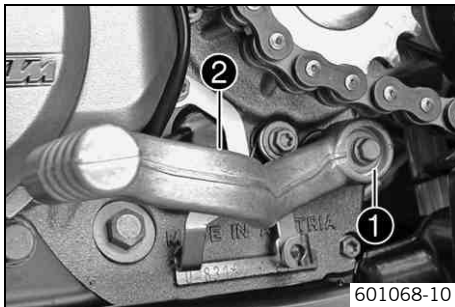

- Remove screw **1** and take off shift lever **2**.

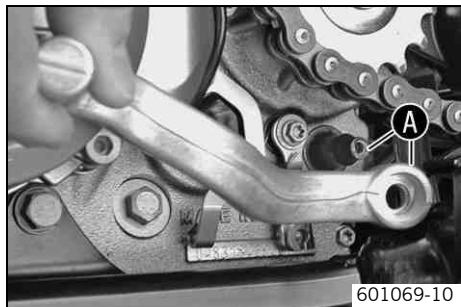

- Clean gear teeth **A** of the shift lever and shift shaft.
- Position the shift lever in the desired position on the shift shaft and engage the gearing.

**i** **Info**

The range of adjustment is limited.  
The shift lever should not come into contact with other vehicle components during shifting.

- Mount and tighten the screw.

Guideline

Screw, shift lever	M6	10 Nm (7.4 lbf ft)	<b>Loctite® 243™</b>
--------------------	----	-----------------------	----------------------

## Checking the engine oil level



### Info

The engine oil level can be checked on a cold or hot engine.

- Park the vehicle on a horizontal surface.

### Condition

The engine is at operating temperature.

- Check the engine oil level.



### Info

After switching off the engine, wait one minute before checking the level.

The engine oil reaches the middle of the viewer **A**.

- » When the engine oil does not reach the middle of the viewer **A**:
  - Add engine oil. (🔧 p. 180)

### Condition

The engine is cold.

- Check the engine oil level.

The engine oil reaches the bottom of the viewer **B**.

- » When the engine oil does not reach the bottom of the viewer **B**:
  - Add engine oil. (🔧 p. 180)

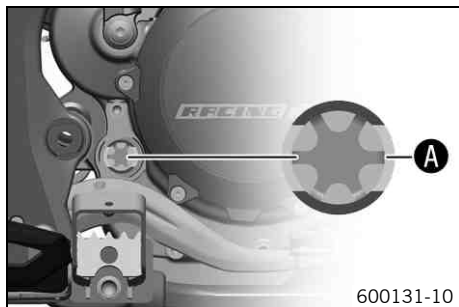



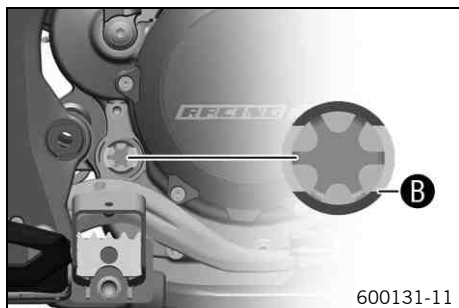

600131-10



600131-11

## Changing engine oil and oil filter, cleaning oil screens



- Drain engine oil, clean oil screens.  (☞ p. 174)
- Remove the oil filter.  (☞ p. 177)
- Install the oil filter.  (☞ p. 179)
- Fill up with engine oil.  (☞ p. 179)

## Draining engine oil, cleaning oil screens



### Warning

**Danger of scalding** Engine oil and gear oil get very hot when the vehicle is driven.

- Wear suitable protective clothing and gloves. If you scald yourself, hold the affected area under lukewarm water immediately.



### Warning

**Environmental hazard** Hazardous substances cause environmental damage.

- Oil, grease, filters, fuel, cleaners, brake fluid, etc., should be disposed of as stipulated in applicable regulations.



### Info

Drain the engine oil only when the engine is warm.

- Park the vehicle on a horizontal surface.
- Remove the engine guard. (☞ p. 125)



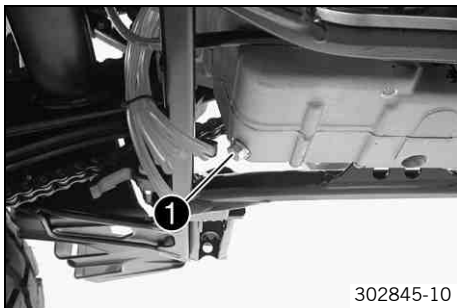

- Place a suitable container under the engine.
- Remove the oil drain plug ❶.

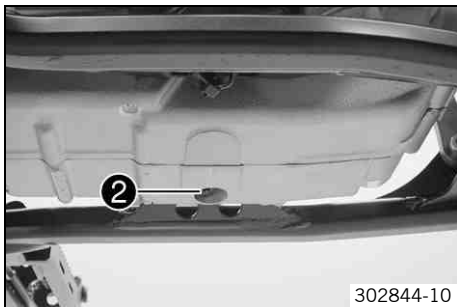

- Remove the plug screw ❷ and small oil screen with both O-rings.

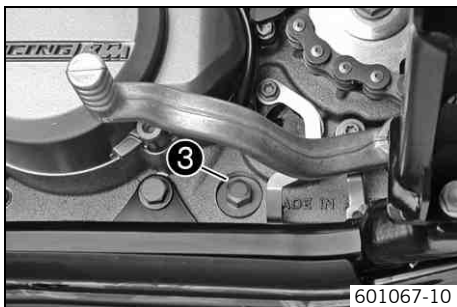

- Remove the plug screw ❸ and large oil screen with both O-rings.
- Completely drain the engine oil.

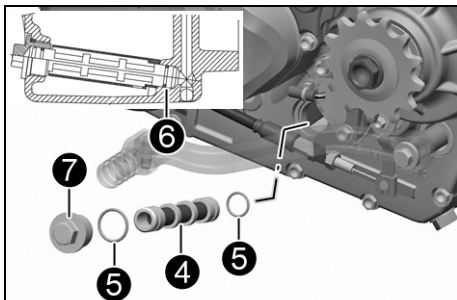

- Thoroughly clean parts and sealing area.
- Oil O-rings **5**, mount them on oil screen **4** and, using a long hexagon key, insert them until the O-ring is seated in the housing **6** with the oil screen.
- Fit plug screw **7** with the seal ring and tighten it.

### Guideline

Locking screw, oil sieve, long	M20x1.5	15 Nm (11.1 lbf ft)
--------------------------------	---------	------------------------

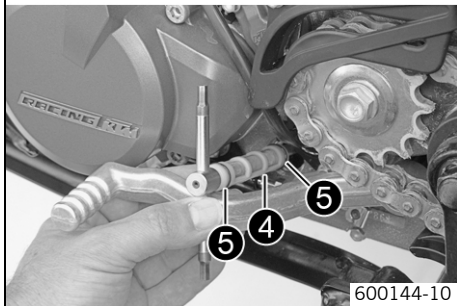

- Insert oil screen **8** with O-rings **9** into plug screw **10** and tighten.

### Guideline

Locking screw, oil sieve, short	M16x1.5	10 Nm (7.4 lbf ft)	Lubricated with engine oil
---------------------------------	---------	-----------------------	----------------------------

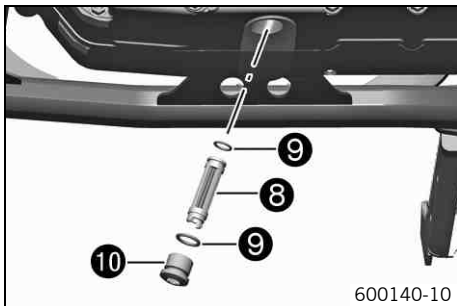

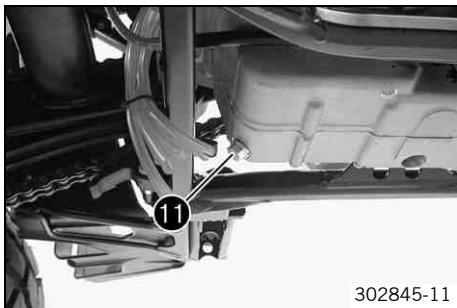

- Fit oil drain plug ⑪ with the seal ring and tighten it.

#### Guideline

Oil drain plug with magnet	M12x1.5	20 Nm (14.8 lbf ft)
----------------------------	---------	------------------------

- Install the engine guard. (☞ p. 125)

## Removing the oil filter ☞



### Warning

**Danger of scalding** Engine oil and gear oil get very hot when the vehicle is driven.

- Wear suitable protective clothing and gloves. If you scald yourself, hold the affected area under lukewarm water immediately.



### Warning

**Environmental hazard** Hazardous substances cause environmental damage.

- Oil, grease, filters, fuel, cleaners, brake fluid, etc., should be disposed of as stipulated in applicable regulations.

- Place a suitable container under the engine.

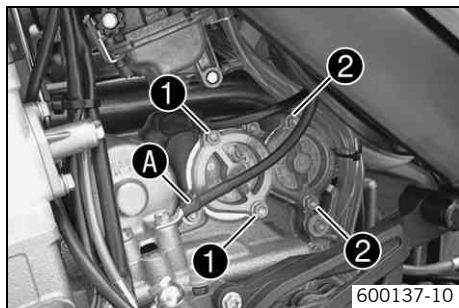

- Disconnect the ground cable **A** from the engine.
- Remove screws **1** and **2**. Take off the oil filter cover with the O-ring.

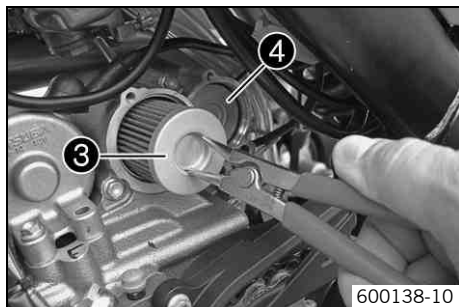

- Pull the oil filters **3** and **4** out of the engine case.

Circlip pliers reverse (51012011000)

- Completely drain the engine oil.
- Thoroughly clean parts and sealing area.

## Installing the oil filter

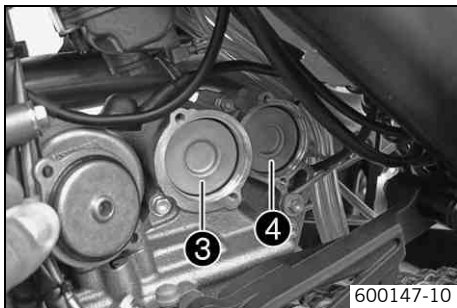

- Fill oil filters ③ and ④ with engine oil and insert them in the oil filter housing.

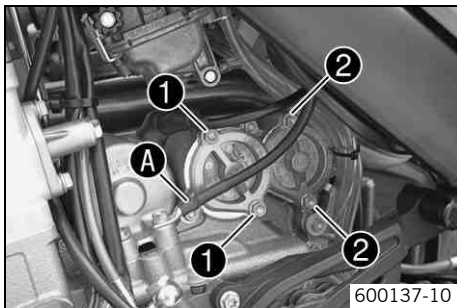

- Oil the O-rings of the oil filter covers and mount them with the oil filter covers. Mount and tighten screws ① and ②.

### Guideline

Screw, oil filter cover	M5	6 Nm (4.4 lbf ft)
-------------------------	----	-------------------

- Connect ground cable ① on the engine and tighten the screw.

### Guideline

Screw, starter engine	M6	10 Nm (7.4 lbf ft)
-----------------------	----	--------------------

## Filling up with engine oil

- i** **Info**  
Too little engine oil or poor-quality engine oil results in premature wear to the engine.



- Remove the screw cap ❶ on the clutch cover and fill up with engine oil.

Engine oil	1.7 l (1.8 qt.)	External temperature: ≥ 0 °C (≥ 32 °F)	Engine oil (SAE 10W/50) (☛ p. 208)
		External temperature: < 0 °C (< 32 °F)	Engine oil (SAE 5W/40) (☛ p. 208)

- Mount and tighten screw cap ❶.



### Danger

**Danger of poisoning** Exhaust gases are poisonous and inhaling them may result in unconsciousness and/or death.

- When running the engine, always make sure there is sufficient ventilation, and do not start or run the engine in an enclosed space without an effective exhaust extraction system.
- 
- Start the engine and check that it is oil-tight.
- Guideline
- |  |
|--|
| Switch off the engine when the radiator fan switches on. |
|--|
- Check the engine oil level. (☛ p. 173)

## Adding engine oil



### Info

A lack of engine oil or poor-quality engine oil results in premature wear to the engine.



- Check the engine for leakage.
- Remove the filler cap ❶ on the clutch cover and fill up with engine oil.

### Condition

External temperature:  $\geq 0$  °C ( $\geq 32$  °F)

Engine oil (SAE 10W/50) (☛ p. 208)

### Condition

External temperature:  $< 0$  °C ( $< 32$  °F)

Engine oil (SAE 5W/40) (☛ p. 208)

### **i** Info

To ensure optimal engine oil performance, it is advisable to not use different engine oils.

We recommend making an oil change in this case.

- Mount and tighten filler cap ❶.

## Cleaning the vehicle

### Note

**Material damage** Damage and destruction of components by high-pressure cleaning equipment.

- Never clean the vehicle with high-pressure cleaning equipment or a strong water-jet. The excessive pressure can penetrate electrical components, socket connects, throttle cables, and bearings, etc., and can damage or destroy these parts.



### Warning

**Environmental hazard** Hazardous substances cause environmental damage.

- Oil, grease, filters, fuel, cleaners, brake fluid, etc., should be disposed of as stipulated in applicable regulations.



### Info

If you clean the vehicle regularly, its value and appearance will be maintained over a long period.  
Avoid direct sunshine on the vehicle during cleaning.



### Info

Do not place the vehicle onto the rear frame bracket to clean it since it could fall over.  
Never raise the vehicle on your own, even if a gear is engaged.  
Fuel can leak out of the fuel tank.

- Close off the exhaust system to prevent water from entering.
- First remove coarse dirt particles with a gentle spray of water.
- Spray very dirty areas with a normal motorcycle cleaner and then clean with a brush.

Motorcycle cleaner (🔧 p. 211)



### Info

Clean the vehicle using a soft sponge and warm water containing normal motorcycle cleaner.



- After rinsing the vehicle with a gentle spray of water, allow it to dry thoroughly.
- Clean the air filter box.
- Empty the carburetor float chamber.  (🔧 p. 169)



## Warning

**Danger of accidents** Reduced braking efficiency due to wet or dirty brakes.

- Clean or dry dirty or wet brakes by riding and braking gently.

- After cleaning, take a short ride until the engine reaches operating temperature.



## Info

The heat produced causes water at inaccessible locations in the engine and the brakes to evaporate.

- Push back the protection covers from the handlebar controls to allow any water that may have entered there to evaporate.
- After the vehicle has cooled off, lubricate all moving parts and bearings.
- Clean the chain. (🔧 p. 114)
- Treat bare metal parts (except for brake discs and exhaust system) with a corrosion inhibitor.

Cleaning and preserving materials for metal, rubber and plastic (🔧 p. 210)

- Treat all plastic parts and powder-coated parts with a mild cleaning and care product.

Paint cleaner and polish for high-gloss and matte finishes, bare metal and plastic surfaces (🔧 p. 212)

- Oil the steering lock.

Universal oil spray (🔧 p. 212)

## Storage



### Warning

**Danger of poisoning** Fuel is poisonous and a health hazard.

- Avoid contact between fuel and skin, eyes and clothing. Do not inhale fuel vapors. If fuel gets into your eyes, rinse immediately with water and contact a doctor. Wash affected skin areas immediately with soap and water. If fuel is swallowed, contact a doctor immediately. Change clothing that has come into contact with fuel. Store fuel in a suitable canister according to regulations and keep it out of the reach of children.



### Info

If you want to store the vehicle for a longer period, take the following actions.

Before storing the vehicle, check all parts for function and wear. If service, repairs, or replacements are necessary, you should do this during the storage period (less workshop overload). In this way, you can avoid long workshop waiting times at the start of the new season.

- Clean the vehicle. (🔧 p. 182)
- Change the engine oil and oil filter, clean the oil screens. 🛢️ (🔧 p. 174)
- Check the antifreeze and coolant level. (🔧 p. 159)
- Drain the fuel from the tank into a suitable container.
- Empty the carburetor float chamber. 🛢️ (🔧 p. 169)
- Check the tire air pressure. (🔧 p. 148)
- Remove the battery. (🔧 p. 150)
- Recharge the battery. 🛢️ (🔧 p. 151)

#### Guideline

Storage temperature of battery without direct sunlight	0... 35 °C (32... 95 °F)
--	--------------------------

- Store the vehicle in a dry location that is not subject to large fluctuations in temperature.

- Cover the vehicle with a tarp or similar cover that is permeable to air.



## Info

Do not use non-porous materials since they prevent humidity from escaping, thus causing corrosion.

Avoid running the engine of a vehicle in storage for a short time only. Because the engine will not warm up sufficiently, the water vapor produced during combustion will condense, causing engine parts and the exhaust system to rust.

---

## Putting the vehicle into operation after storage

- Recharge the battery.  (🔑 p. 151)
- Install the battery. (🔑 p. 151)
- Fill up with fuel. (🔑 p. 64)
- Set the clock. (🔑 p. 29)
- Perform checks and maintenance measures when preparing for use. (🔑 p. 50)
- Take a test ride.

Faults	Possible cause	Action
Engine turns but does not start.	Operating error	<ul style="list-style-type: none"> <li>– Follow the instructions on starting the engine. (☛ p. 51)</li> </ul>
	Vehicle was out of use for a long time and there is old fuel in the float chamber	<ul style="list-style-type: none"> <li>– Empty the carburetor float chamber. ☛ (☛ p. 169)</li> </ul>
	Fuel supply interrupted	<ul style="list-style-type: none"> <li>– Check the fuel tank breather.</li> <li>– Clean the fuel tap.</li> <li>– Check/adjust the carburetor components. ☛</li> </ul>
	Spark plug oily or wet	<ul style="list-style-type: none"> <li>– Clean and dry spark plug or replace if necessary.</li> </ul>
	Electrode distance (plug gap) of spark plug too wide	<ul style="list-style-type: none"> <li>– Adjust the plug gap. Guideline Spark plug electrode gap 0.6 mm (0.024 in)</li> </ul>
	Fault in ignition system	<ul style="list-style-type: none"> <li>– Check the ignition system. ☛</li> </ul>
	Socket connector of CDI control device, pulse generator or ignition coil oxidized	<ul style="list-style-type: none"> <li>– Clean the plug-in connector and treat it with contact spray.</li> </ul>
	Water in carburetor or jets is blocked	<ul style="list-style-type: none"> <li>– Check/adjust the carburetor components. ☛</li> </ul>
	Idle speed is set too high	<ul style="list-style-type: none"> <li>– Carburetor - adjust the idle speed. ☛ (☛ p. 167)</li> </ul>
	Adjusting screws on carburetor distorted	<ul style="list-style-type: none"> <li>– Carburetor - adjust the idle speed. ☛ (☛ p. 167)</li> </ul>
	Idling jet blocked	<ul style="list-style-type: none"> <li>– Check/adjust the carburetor components. ☛</li> </ul>
Loose carburetor jets	<ul style="list-style-type: none"> <li>– Check/adjust the carburetor components. ☛</li> </ul>	

Faults	Possible cause	Action
Engine turns but does not start.	Emergency OFF switch with rip cord faulty	<ul style="list-style-type: none"> <li>– Check the wiring harness. (visual check)</li> <li>– Check the electrical system.</li> </ul>
	Throttle lever activated	<ul style="list-style-type: none"> <li>– Do not activate the throttle lever.</li> <li>– Follow the instructions on starting the engine. (☛ p. 51)</li> </ul>
	Switch for throttle lever faulty	<ul style="list-style-type: none"> <li>– Check the wiring harness. (visual check)</li> <li>– Check the electrical system.</li> </ul>
	Blown fuse	<ul style="list-style-type: none"> <li>– Change the fuses of individual power consumers. (☛ p. 154)</li> </ul>
Engine cannot be cranked (electric starter)	Operating error	<ul style="list-style-type: none"> <li>– Follow the instructions on starting the engine. (☛ p. 51)</li> </ul>
	Battery discharged	<ul style="list-style-type: none"> <li>– Recharge the battery. ☛ (☛ p. 151)</li> <li>– Check the charging voltage. ☛</li> <li>– Check the quiescent current. ☛</li> <li>– Check the alternator. ☛</li> </ul>
	Blown fuse	<ul style="list-style-type: none"> <li>– Change the main fuse. (☛ p. 153)</li> </ul>
	Start relay faulty	<ul style="list-style-type: none"> <li>– Check the starter relay. ☛</li> </ul>
	Starter motor faulty	<ul style="list-style-type: none"> <li>– Check the starter motor. ☛</li> </ul>
Engine does not speed up	Carburetor running over because float needle is dirty or worn	<ul style="list-style-type: none"> <li>– Check/adjust the carburetor components. ☛</li> </ul>
	Loose carburetor jets	<ul style="list-style-type: none"> <li>– Check/adjust the carburetor components. ☛</li> </ul>

Faults	Possible cause	Action
Engine does not speed up	Ignition system defective	<ul style="list-style-type: none"> <li>- Check the spark plug connector. 🔧</li> <li>- Check the ignition coil. 🔧</li> <li>- Check the ignition pulse generator. 🔧</li> <li>- Check the alternator. 🔧</li> <li>- Check the CDI controller. 🔧</li> </ul>
Engine has no idle.	Idling jet blocked	<ul style="list-style-type: none"> <li>- Check/adjust the carburetor components. 🔧</li> </ul>
	Adjusting screws on carburetor distorted	<ul style="list-style-type: none"> <li>- Carburetor - adjust the idle speed. 🔧 (🔧 p. 167)</li> </ul>
	Spark plug defective	<ul style="list-style-type: none"> <li>- Change spark plug.</li> </ul>
	Ignition system defective	<ul style="list-style-type: none"> <li>- Check the spark plug connector. 🔧</li> <li>- Check the ignition coil. 🔧</li> <li>- Check the ignition pulse generator. 🔧</li> <li>- Check the alternator. 🔧</li> <li>- Check the CDI controller. 🔧</li> </ul>
Engine stalls or is backfiring into the carburetor.	Lack of fuel	<ul style="list-style-type: none"> <li>- Turn the handle 🛠 of the fuel tap to <b>ON</b>. (Figure 100013-10🔧 p. 42)</li> <li>- Fill up with fuel. (🔧 p. 64)</li> </ul>
	Intake system air leak	<ul style="list-style-type: none"> <li>- Check rubber sleeves and carburetor for tightness.</li> </ul>
	Loose contact or oxidized connector	<ul style="list-style-type: none"> <li>- Check the electrical system.</li> <li>- Clean the plug-in connector and treat it with contact spray.</li> </ul>
Engine overheats.	Coolant level low	<ul style="list-style-type: none"> <li>- Check the cooling system for leakage.</li> <li>- Check the coolant level. (🔧 p. 160)</li> </ul>

Faults	Possible cause	Action
Engine overheats.	Radiator fins excessively dirty	– Clean radiator fins.
	Foam formation in cooling system	– Drain the coolant. 🛠️ (📖 p. 161) – Fill coolant/bleed cooling system. 🛠️ (📖 p. 163)
	Bent radiator hose	– Change the radiator hose. 🛠️
	Thermostat defective	– Check the thermostat. 🛠️
	Radiator fan system faulty	– Check the radiator fan system. 🛠️
Engine has a lack of power	Fuel supply interrupted	– Check the fuel tank breather. – Clean the fuel tap. – Check/adjust the carburetor components. 🛠️
	Air filter excessively dirty	– Clean the air filter and air filter box. 🛠️ (📖 p. 101)
	Exhaust system leaky, deformed or too little glass fiber yarn filling in main silencer	– Check exhaust system for damage.
	Valve clearance too little	– Adjust the valve clearance. 🛠️
	Ignition system defective	– Check the spark plug connector. 🛠️ – Check the ignition coil. 🛠️ – Check the ignition pulse generator. 🛠️ – Check the alternator. 🛠️ – Check the CDI controller. 🛠️
High oil consumption	Engine vent hose bent	– Route the vent hose without bends or replace it if necessary.
	Engine oil level too high	– Check the engine oil level. (📖 p. 173)

Faults	Possible cause	Action
High oil consumption	Engine oil too thin (low viscosity)	– Change the engine oil and oil filter, clean the oil screens. 🛠️ (📖 p. 174)
	Piston or cylinder worn	– Check the piston/cylinder mounting clearance. 🛠️
Parts of the electrical system are not functional.	Fault in the electrical system	– Change the fuses of individual power consumers. (📖 p. 154) – Check the electrical system.
Battery discharged	Battery is not charged by alternator	– Check the charging voltage. 🛠️ – Check the alternator. 🛠️
	Undesired power consumer	– Check the quiescent current. 🛠️
Speedometer values deleted (time, stop watch, lap times)	The battery in the speedometer is discharged	– Change the speedometer battery.



Design	1-cylinder 4-stroke engine with balancer, water-cooled
Displacement	510 cm <sup>3</sup> (31.12 cu in)
Stroke	72 mm (2.83 in)
Bore	95 mm (3.74 in)
Compression ratio	11:1
Idle speed	1,500... 1,600 rpm
Control	4 valves controlled via rocker arm and overhead camshaft, camshaft drive via simplex chain
Valve diameter, intake	35 mm (1.38 in)
Valve diameter, exhaust	30 mm (1.18 in)
Valve clearance, cold, intake	0.10... 0.15 mm (0.0039... 0.0059 in)
Valve clearance, cold, exhaust	0.10... 0.15 mm (0.0039... 0.0059 in)
Crankshaft bearing	2 cylinder roller bearing
Conrod bearing	Needle bearing
Piston pin bearing	Bronze bush
Pistons	Forged light alloy
Piston rings	1 compression ring, 1 oil scraper ring
Engine lubrication	Pressure circulation lubrication with 2 rotor pumps
Primary transmission	31:78 straight tooth spur gears
Clutch	Multidisc clutch in oil bath / hydraulically activated
Transmission ratio	
1st gear	14:35
2nd gear	17:33
3rd gear	19:30
4th gear	21:28

5th gear	23:26
Alternator	12 V, 200 W
Ignition	Contactless controlled fully electronic ignition with digital ignition adjustment, type Kokusan
Spark plug	NGK DCPR 8 E
Spark plug electrode gap	0.6 mm (0.024 in)
Cooling	Water cooling, permanent circulation of coolant by water pump
Starting aid	Electric starter

## Capacity - engine oil

Engine oil	1.7 l (1.8 qt.)	External temperature: $\geq 0\text{ }^{\circ}\text{C}$ ( $\geq 32\text{ }^{\circ}\text{F}$ )	Engine oil (SAE 10W/50) (☛ p. 208)
		External temperature: $< 0\text{ }^{\circ}\text{C}$ ( $< 32\text{ }^{\circ}\text{F}$ )	Engine oil (SAE 5W/40) (☛ p. 208)

## Capacity - coolant

Coolant	1.30 l (1.37 qt.)	Coolant (☛ p. 207)
		Coolant (mixed ready to use) (☛ p. 207)

# TECHNICAL DATA - ENGINE TIGHTENING TORQUES

Screw, cable holder in alternator cover	M4	4 Nm (3 lbf ft)	Loctite® 243™
Locking screw for bearing	M5	6 Nm (4.4 lbf ft)	Loctite® 243™
Screw, gear sensor	M5	6 Nm (4.4 lbf ft)	Loctite® 243™
Screw, ignition pulse generator	M5	6 Nm (4.4 lbf ft)	Loctite® 243™
Screw, locking lever	M5	6 Nm (4.4 lbf ft)	Loctite® 243™
Screw, locking shaft lever	M5	6 Nm (4.4 lbf ft)	Loctite® 243™
Screw, oil filter cover	M5	6 Nm (4.4 lbf ft)	–
Screw, oil pump cover	M5	6 Nm (4.4 lbf ft)	Loctite® 222
Screw, rocker arm shaft	M5	6 Nm (4.4 lbf ft)	–
Screw, stator bracket	M5	6 Nm (4.4 lbf ft)	Loctite® 243™
Screw, timing chain securing guide	M5	6 Nm (4.4 lbf ft)	Loctite® 243™
Screw on cylinder head top section	M6x45	10 Nm (7.4 lbf ft)	–
Screw on cylinder head top section	M6x50	10 Nm (7.4 lbf ft)	–
Screw on cylinder head top section	M6x55 – 10.9	10 Nm (7.4 lbf ft)	–
Screw on cylinder head top section	M6x75	10 Nm (7.4 lbf ft)	–
Screw, bearing stud, starter engine	M6	10 Nm (7.4 lbf ft)	Loctite® 243™
Screw, clutch cover	M6	10 Nm (7.4 lbf ft)	–
Screw, clutch spring	M6	8 Nm (5.9 lbf ft)	Loctite® 243™
Screw, cylinder head	M6	10 Nm (7.4 lbf ft)	–
Screw, cylinder head top section	M6x30	10 Nm (7.4 lbf ft)	–
Screw, drive wheel for balancer	M6	10 Nm (7.4 lbf ft)	Loctite® 243™
Screw, engine case	M6x30	10 Nm (7.4 lbf ft)	–
Screw, engine case	M6x45	10 Nm (7.4 lbf ft)	–
Screw, engine case	M6x60	10 Nm (7.4 lbf ft)	–

# TECHNICAL DATA - ENGINE TIGHTENING TORQUES

Screw, engine case	M6x65	10 Nm (7.4 lbf ft)	–
Screw, engine case	M6x75	10 Nm (7.4 lbf ft)	–
Screw, exhaust flange	M6	10 Nm (7.4 lbf ft)	<b>Loctite® 243™</b>
Screw, shift drum locating	M6	10 Nm (7.4 lbf ft)	<b>Loctite® 243™</b>
Screw, shift lever	M6	10 Nm (7.4 lbf ft)	<b>Loctite® 243™</b>
Screw, starter engine	M6	10 Nm (7.4 lbf ft)	–
Screw, timing chain guide rail	M6	6 Nm (4.4 lbf ft)	<b>Loctite® 243™</b>
Screw, timing chain tensioning rail	M6	6 Nm (4.4 lbf ft)	<b>Loctite® 243™</b>
Screw, timing-chain tensioner	M6	10 Nm (7.4 lbf ft)	–
Screw, valve cover	M6	10 Nm (7.4 lbf ft)	–
Screw, vent hose bracket	M6	10 Nm (7.4 lbf ft)	<b>Loctite® 243™</b>
Screw, water pump cover	M6	10 Nm (7.4 lbf ft)	–
Nut, adjusting screw, valve clearance	M6x0.75	11 Nm (8.1 lbf ft)	–
Oil jet, piston cooling	M6x0.75	4 Nm (3 lbf ft)	<b>Loctite® 243™</b>
Banjo bolt, oil line	M8	10 Nm (7.4 lbf ft)	–
Jet screw, oil line	M8	10 Nm (7.4 lbf ft)	–
Plug, crankshaft location	M8	10 Nm (7.4 lbf ft)	–
Plug, timing chain tensioner	M8	10 Nm (7.4 lbf ft)	–
Screw, alternator cover	M8	10 Nm (7.4 lbf ft)	–
Screw, camshaft gear	M8	28 Nm (20.7 lbf ft)	<b>Loctite® 243™</b>
Screw, cylinder head	M10	Step 1 40 Nm (29.5 lbf ft) Step 2 50 Nm (36.9 lbf ft)	–
Screw, engine sprocket	M10	60 Nm (44.3 lbf ft)	<b>Loctite® 243™</b>

# TECHNICAL DATA - ENGINE TIGHTENING TORQUES

Nut, rotor	M12x1	60 Nm (44.3 lbf ft)	–
Spark plug	M12x1.25	17 Nm (12.5 lbf ft)	–
Bleeder flange, engine case	M12x1.5		<b>Loctite® 243™</b>
Oil drain plug with magnet	M12x1.5	20 Nm (14.8 lbf ft)	–
Plug, oil pressure regulator valve	M12x1.5	20 Nm (14.8 lbf ft)	–
Locking screw, oil sieve, short	M16x1.5	10 Nm (7.4 lbf ft)	Lubricated with engine oil
Nut, inner clutch hub	M18x1.5	120 Nm (88.5 lbf ft)	<b>Loctite® 243™</b>
Locking screw, oil sieve, long	M20x1.5	15 Nm (11.1 lbf ft)	–
Nut, primary gear	M20LHx1.5	150 Nm (110.6 lbf ft)	<b>Loctite® 243™</b>
Screw-in fitting, cooling system in cylinder head top	M20x1.5		<b>Loctite® 577</b>

Carburetor type	KEIHIN FCR-MX 39
Carburetor identification number	3925H
Needle position	2 th position from top
Idle mixture adjusting screw	
Open	1.0 turn
Pump membrane stop	2.15 mm (0.0846 in)
Main jet	170
Jet needle	OBDVT
Idling jet	42
Main air jet	200
Idle air jet	100
Cold start jet	85
Throttle slide	15

Frame	Double cradle of chromium molybdenum steel tubes, powder-coated
Wheel suspension	
Front	Single wheel suspension with double transverse control arm
Rear	Rigid axle
Suspension travel	
Front	275 mm (10.83 in)
Rear	272 mm (10.71 in)
Fork offset	
Front	46 mm (1.81 in)
Toe	
Front	0 mm (0 in)
Camber	
Front	0°
Toe width	
Front	1,115 mm (43.9 in)
Rear	1,148 mm (45.2 in)
Wheelbase	1,280±10 mm (50.39±0.39 in)
Turning radius	5,625 mm (221.46 in)
Fording depth	330 mm (12.99 in)
Seat height unloaded	820 mm (32.28 in)
Ground clearance unloaded	290 mm (11.42 in)
Weight	
Fuel tank empty	168 kg (370 lb.)
Fuel tank full	176 kg (388 lb.)

Maximum allowable axle load	
Front	160 kg (353 lb.)
Rear	190 kg (419 lb.)
Maximum permissible overall weight	
335 kg (739 lb.)	
Vehicle length	
1,810 mm (71.26 in)	
Vehicle width	
1,148 mm (45.2 in)	
Vehicle height	
1,125 mm (44.29 in)	
Brake system	
Front	Disc brakes, brake calipers fixed, 4 brake pistons per brake caliper
Rear	Disc brake, brake caliper floating, 1 brake piston
Brake discs - diameter	
Front	180 mm (7.09 in)
Rear	200 mm (7.87 in)
Brake discs - wear limit	
Front	3.5 mm (0.138 in)
Rear	3.5 mm (0.138 in)
Tire air pressure	
1.0 bar (15 psi)	
Rim	
Front	5x10" DWT Al 6061
Rear	8x9" DWT Al 6061
Rear wheel gearing	
15:37	
Chain	
5/8 x 1/4"	
Rear sprockets available	
37, 38, 39	



Battery	YTX5L-BS	Battery voltage: 12 V Nominal capacity: 4 Ah maintenance-free
---------	----------	---

## Lighting equipment

Headlight	S2/socket BA20d	12 V 35/35 W
Parking light	W5W/socket W2.1x9.5d	12 V 5 W
Indicator lights	W1.2W/socket W2x4.6d	12 V 1.2 W
Turn signal	R10W/socket BA15s	12 V 10 W
Brake / tail light	LED	
License plate lamp	W5W/socket W2.1x9.5d	12 V 5 W

## Tires

Front tire	Rear tire
<b>21 x 7.00 - 10</b>	<b>20 x 11.00 - 9</b>
Additional information is available in the Service section under: <a href="http://www.ktm.com">http://www.ktm.com</a>	

## Capacity - fuel

Total fuel tank capacity approx.	13.5 l (3.57 US gal)	Super unleaded (ROZ 95 / RON 95 / PON 91) (☛ p. 209)
Fuel reserve approx.	3 l (3 qt.)	

## Option: KT 770...

Shock absorber type	36PRC
Setting number	KT 770...
Compression damping	
Standard	14 clicks
Maximum deviation from standard value	-5... 5 clicks
Rebound damping	
Standard	20 clicks
Maximum deviation from standard value	-5... 5 clicks
Cross over	17±1.5 mm (0.67±0.059 in)
Clip position, spring preload	
Standard	7 th position from top
Corresponds to a spring preload of	5 mm (0.2 in)
Spring preload	5 mm (0.2 in)
Spring rate, main spring	21... 30 N/mm (120... 171 lb/in)
Spring rate, auxiliary spring	30 N/mm (171 lb/in)
Spring length, main spring	275 mm (10.83 in)
Spring length, auxiliary spring	60 mm (2.36 in)
Fitted length	463 mm (18.23 in)

## Option: KT 870...

Shock absorber type	36PRC
Setting number	KT 870...
Compression damping	

Standard	15 clicks
Maximum deviation from standard value	-5... 5 clicks
Rebound damping	
Standard	20 clicks
Maximum deviation from standard value	-5... 5 clicks
Cross over	14±1.5 mm (0.55±0.059 in)
Clip position, spring preload	
Standard	8th position from top
Corresponds to a spring preload of	9 mm (0.35 in)
Spring preload	9 mm (0.35 in)
Spring rate, main spring	21... 30 N/mm (120... 171 lb/in)
Spring rate, auxiliary spring	30 N/mm (171 lb/in)
Spring length, main spring	275 mm (10.83 in)
Spring length, auxiliary spring	60 mm (2.36 in)
Fitted length	460 mm (18.11 in)

## Option: KT 771...

Shock absorber type	46PRCQ
Setting number	KT 771...
Compression damping	
Standard	15 clicks
Maximum deviation from standard value	-5... 5 clicks
Rebound damping	
Standard	15 clicks
Maximum deviation from standard value	-5... 5 clicks
Spring preload	
Standard	3 mm (0.12 in)
Spring rate	62 N/mm (354 lb/in)
Spring length	250 mm (9.84 in)
Fitted length	457 mm (17.99 in)

## Option: KT 871...

Shock absorber type	46PRCQ
Setting number	KT 871...
Compression damping	
Standard	17 clicks
Maximum deviation from standard value	-5... 5 clicks
Rebound damping	
Standard	15 clicks
Maximum deviation from standard value	-5... 5 clicks

# TECHNICAL DATA - REAR SHOCK ABSORBER

Spring preload	
Standard	3 mm (0.12 in)
Spring rate	62 N/mm (354 lb/in)
Spring length	250 mm (9.84 in)
Fitted length	449 mm (17.68 in)

# TECHNICAL DATA - CHASSIS TIGHTENING TORQUES

Remaining nuts, chassis	M6	15 Nm (11.1 lbf ft)	–
Remaining screws, chassis	M6	10 Nm (7.4 lbf ft)	–
Screw on fuel tank	M6	6 Nm (4.4 lbf ft)	–
Screw, clamping nut, rear axle	M6	10 Nm (7.4 lbf ft)	–
Screw, foot brake cylinder	M6	7 Nm (5.2 lbf ft)	<b>Loctite® 243™</b>
Screw, rear brake caliper	M6	10 Nm (7.4 lbf ft)	<b>Loctite® 243™</b>
Remaining nuts, chassis	M8	30 Nm (22.1 lbf ft)	–
Remaining screws, chassis	M8	25 Nm (18.4 lbf ft)	–
Screw, bearing support, steering	M8	25 Nm (18.4 lbf ft)	–
Screw, chain sliding piece	M8	15 Nm (11.1 lbf ft)	–
Screw, front brake caliper	M8	20 Nm (14.8 lbf ft)	<b>Loctite® 243™</b>
Screw, front brake disc	M8	25 Nm (18.4 lbf ft)	<b>Loctite® 243™</b>
Screw, handlebar clamp	M8	20 Nm (14.8 lbf ft)	–
Screw, rear brake caliper	M8	20 Nm (14.8 lbf ft)	<b>Loctite® 243™</b>
Screw, rear brake disc	M8	25 Nm (18.4 lbf ft)	<b>Loctite® 243™</b>
Screw, rear wheel eccentric element	M8	20 Nm (14.8 lbf ft)	–
Screw, steering bridge	M8	20 Nm (14.8 lbf ft)	–
Screw, subframe	M8	35 Nm (25.8 lbf ft)	<b>Loctite® 243™</b>
Engine bracket screw	M10	60 Nm (44.3 lbf ft)	–
Engine mounting bolt	M10	60 Nm (44.3 lbf ft)	–
Nut, handlebar support	M10	45 Nm (33.2 lbf ft)	–
Remaining nuts, chassis	M10	50 Nm (36.9 lbf ft)	–
Remaining screws, chassis	M10	45 Nm (33.2 lbf ft)	–
Screw, A-arm bottom	M10x70	45 Nm (33.2 lbf ft)	–

# TECHNICAL DATA - CHASSIS TIGHTENING TORQUES

Screw, A-arm top	M10x52	45 Nm (33.2 lbf ft)	–
Screw, footrest	M10	45 Nm (33.2 lbf ft)	–
Screw, front shock absorber	M10	45 Nm (33.2 lbf ft)	–
Screw, steering column at bottom of steering lever	M10	25 Nm (18.4 lbf ft)	–
Nut, ball head, A-arm top	M10x1.25	35 Nm (25.8 lbf ft)	–
Nut, rear sprocket screw	M10x1.25	45 Nm (33.2 lbf ft)	<b>Loctite® 243™</b>
Nut, tie rod end	M10x1.25	45 Nm (33.2 lbf ft)	–
Wheel nut	M10x1.25	45 Nm (33.2 lbf ft)	–
Nut, front wheel hub	M12	70 Nm (51.6 lbf ft)	–
Screw, rear bottom shock absorber	M12	70 Nm (51.6 lbf ft)	–
Screw, rear top shock absorber	M12	60 Nm (44.3 lbf ft)	–
Lock nut, tie rod, inside	M12LHx1.25	20 Nm (14.8 lbf ft)	–
Lock nut, tie rod, outside	M12x1.25	20 Nm (14.8 lbf ft)	–
Nut, A-arm top	M12x1.25	30 Nm (22.1 lbf ft)	–
Nut, ball head, A-arm bottom	M12x1.5	40 Nm (29.5 lbf ft)	–
Nut, swingarm pivot	M16x1.5	100 Nm (73.8 lbf ft)	–
Nut, rear wheel hub	M18x1.5	130 Nm (95.9 lbf ft)	–
Screw, steering column, bottom	M20x1.5	40 Nm (29.5 lbf ft)	–
Screw, steering column, top	M20x1.5	25 Nm (18.4 lbf ft)	–
Clamping nut, rear axle	2"-10UNS-2B-LH	25 Nm (18.4 lbf ft)	Only applies when using: Open-end wrench attachment, 46 mm (83019010461)



## Brake fluid DOT 4 / DOT 5.1

### According to

- DOT

### Guideline

- Use only brake fluid that complies with the specified standard (see specifications on the container) and that possesses the corresponding properties. KTM recommends **Castrol** and **Motorex®** products.

### Supplier

#### Castrol

- **RESPONSE BRAKE FLUID SUPER DOT 4**

#### Motorex®

- **Brake Fluid DOT 5.1**

## Coolant

### Guideline

- Use only suitable coolant (also in countries with high temperatures). Use of low-quality antifreeze can lead to corrosion and foaming. KTM recommends **Motorex®** products.

### Mixture ratio

Antifreeze protection: -25... -45 °C (-13... -49 °F)	50 % corrosion inhibitor/antifreeze 50 % distilled water
--	---

## Coolant (mixed ready to use)

Antifreeze	-40 °C (-40 °F)
------------	-----------------

### Supplier

#### Motorex®

- **Anti Freeze**

## Engine oil (SAE 10W/50)

### According to

- JASO T903 MA (☛ p. 213)
- SAE (☛ p. 213) (SAE 10W/50)

### Guideline

- Use only engine oils that comply with the specified standards (see specifications on the container) and that possess the corresponding properties. KTM recommends **Motorex**<sup>®</sup> products.

Synthetic engine oil

### Supplier

#### Motorex<sup>®</sup>

- **Cross Power 4T**

## Engine oil (SAE 5W/40)

### According to

- JASO T903 MA (☛ p. 213)
- SAE (☛ p. 213) (SAE 5W/40)

### Guideline

- Use only engine oils that comply with the specified standards (see specifications on the container) and that possess the corresponding properties. KTM recommends **Motorex**<sup>®</sup> products.

Synthetic engine oil

### Supplier

#### Motorex<sup>®</sup>

- **Power Synt 4T**

## Hydraulic fluid (15)

### According to

- ISO VG (15)

### Guideline

- Use only hydraulic oil that complies with the specified standard (see specifications on the container) and that possesses the corresponding properties. KTM recommends **Motorex®** products.

### Supplier

#### Motorex®

- **Hydraulic Fluid 75**

## Long-life grease

### According to

- NLGI

### Guideline

- Use only grease that complies with the specified standards (see specifications on the container) and that possesses the corresponding properties. KTM recommends **Motorex®** products.

### Supplier

#### Motorex®

- **Fett 2000**

## Super unleaded (ROZ 95 / RON 95 / PON 91)

### According to

- DIN EN 228 (ROZ 95 / RON 95 / PON 91)

## Air filter cleaner

### Guideline

- KTM recommends **Motorex®** products.

### Supplier

#### Motorex®

- **Twin Air Dirt Bio Remover**

## Chain cleaner

### Guideline

- KTM recommends **Motorex®** products.

### Supplier

#### Motorex®

- **Chain Clean**

## Chain lube for road use

### Guideline

- KTM recommends **Motorex®** products.

### Supplier

#### Motorex®

- **Chainlube Road**

## Cleaning and preserving materials for metal, rubber and plastic

### Guideline

- KTM recommends **Motorex®** products.

### Supplier

#### Motorex®

- **Protect & Shine**

## Long-life grease

### Guideline

- KTM recommends **Motorex®** products.

### Supplier

#### Motorex®

- **Bike Grease 2000**

## Lubricant (T625)

### Guideline

- KTM recommends **Molykote®** products.

### Supplier

#### Molykote®

- **33 Medium**

## Motorcycle cleaner

### Guideline

- KTM recommends **Motorex®** products.

### Supplier

#### Motorex®

- **Moto Clean 900**

## Oil for foam air filter

### Guideline

- KTM recommends **Motorex®** products.

### Supplier

#### Motorex®

- **Twin Air Liquid Bio Power**

## Paint cleaner and polish for high-gloss and matte finishes, bare metal and plastic surfaces

### Guideline

- KTM recommends **Motorex®** products.

### Supplier

#### Motorex®

- **Clean & Polish**

## Universal oil spray

### Guideline

- KTM recommends **Motorex®** products.

### Supplier

#### Motorex®

- **Joker 440 Synthetic**

## JASO T903 MA

Different technical development directions required a new specification for 4-stroke motorcycles – the JASO T903 MA Standard. Earlier, engine oils from the automobile industry were used for 4-stroke motorcycles because there was no separate motorcycle specification. Whereas long service intervals are demanded for automobile engines, high performance at high engine speeds are in the foreground for motorcycle engines. With most motorcycles, the gearbox and the clutch are lubricated with the same oil as the engine. The JASO MA Standard meets these special requirements.

## SAE

The SAE viscosity classes were defined by the Society of Automotive Engineers and are used for classifying oils according to their viscosity. The viscosity describes only one property of oil and says nothing about quality.

<b>A</b>	
<b>Accessories</b> .....	8
<b>Air filter</b>	
cleaning .....	101
installing .....	100
removing .....	98
<b>Air filter box</b>	
cleaning .....	101
<b>Antifreeze</b>	
checking .....	159
<b>B</b>	
<b>Basic information on changing the chassis settings</b> .....	70
<b>Battery</b>	
installing .....	151
recharging .....	151
removing .....	150
<b>Brake discs</b>	
checking .....	127
<b>Brake fluid level of front brake</b>	
checking .....	128
<b>Brake fluid of front brake</b>	
topping up .....	129
<b>Brake fluid of rear brake</b>	
checking .....	138
topping up .....	139

<b>Brake linings of front brake</b>	
changing .....	132
checking .....	131
installing .....	135
removing .....	134
<b>Brake linings of rear brake</b>	
changing .....	141
checking .....	140
installing .....	144
removing .....	142
<b>C</b>	
<b>Camber</b>	
adjusting .....	111
checking .....	111
<b>Carburetor</b>	
adjusting idle .....	167
emptying the float chamber .....	169
idle .....	170
<b>Chain</b>	
checking .....	118
cleaning .....	114
<b>Chain guide</b>	
checking .....	118
<b>Chain tension</b>	
adjusting .....	116
checking .....	115
<b>Chassis number</b> .....	16



<b>Choke</b> .....	43
<b>Clutch</b>	
fluid level, checking .....	124
<b>Clutch lever</b> .....	<b>19</b>
basic position, adjusting .....	124
<b>Coolant</b>	
draining .....	161
refilling .....	163
<b>Coolant level</b>	
checking .....	159-160
<b>Cooling system</b> .....	<b>158</b>
bleeding .....	163
<b>E</b>	
<b>Electric starter button</b> .....	25
<b>Emergency OFF switch with rip cord</b> .....	26
<b>Engine</b>	
running in .....	49
switching off .....	61
<b>Engine guard</b>	
installing .....	125
removing .....	125
<b>Engine number</b> .....	17
<b>Engine oil</b>	
adding .....	180
changing .....	174
draining .....	174

refilling .....	179
<b>Engine oil level</b>	
checking .....	173
<b>Engine sprocket</b>	
checking .....	118
<b>Environment</b> .....	10
<b>F</b>	
<b>Fender, rear</b>	
installing .....	95
removing .....	94
<b>Filler cap</b>	
closing .....	41
opening .....	41
<b>Filling up</b>	
fuel .....	64
<b>Foot brake lever</b> .....	<b>45</b>
basic position, adjusting .....	137
free travel, checking .....	136
<b>Front cover</b>	
installing .....	93
removing .....	93
<b>Front shock absorber</b>	
compression damping, adjusting .....	70
cross over, adjusting .....	76
rebound damping, adjusting .....	72
setting number .....	18

spring preload, adjusting	74
<b>Front trim</b>	
installing	106
removing	104
<b>Fuel tank</b>	
installing	103
removing	102
<b>Fuel tap</b>	42
<b>Fuel, oils, etc.</b>	8
<b>Fuse</b>	
fuses, changing for individual power consumers	154
main fuse, changing	153
<b>H</b>	
<b>Hand brake lever</b>	20
basic position, adjusting	126
free travel, checking	126
<b>Handlebar position</b>	84
adjusting	85
<b>Hazard warning flasher</b>	25
<b>Hazard warning flasher switch</b>	25
<b>Headlight setting</b>	
checking	156
headlight range, adjusting	157
<b>Horn button</b>	24
<b>Hot start button</b>	43

<b>I</b>	
<b>Ignition switch</b>	24
<b>Indicator lamp overview</b>	26
<b>K</b>	
<b>Key number</b>	17
<b>Kill switch</b>	22
<b>L</b>	
<b>Light switch</b>	23
<b>M</b>	
<b>Main fuse</b>	
changing	153
<b>O</b>	
<b>Oil filter</b>	
changing	174
installing	179
removing	177
<b>Oil screens</b>	
cleaning	174
<b>Owner's manual</b>	11
<b>P</b>	
<b>Parking</b>	63
<b>Parking brake</b>	21
front	20
rear	21

**Play in throttle cable**

- adjusting . . . . . 166
- checking . . . . . 166

**Putting into operation**

- advice on first use . . . . . 47
- after storage . . . . . 185
- checks and maintenance measures when preparing for use . 50

**R****Radiator fan . . . . . 158****Radiator spoiler**

- installing . . . . . 91
- removing . . . . . 90

**Rear shock absorber**

- compression damping, adjusting . . . . . 78
- installing . . . . . 90
- rebound damping, adjusting . . . . . 80
- removing . . . . . 88
- setting number . . . . . 18
- spring preload, adjusting . . . . . 81

**Rear sprocket**

- checking . . . . . 118

**Rear wheel eccentric element**

- greasing . . . . . 123

**Rider training . . . . . 10****Riding**

- bends . . . . . 56
- brakes . . . . . 54

- downhill . . . . . 57
- engine, switching off . . . . . 61
- general information . . . . . 55
- perpendicular to the slope . . . . . 59
- riding through water . . . . . 61
- starting up . . . . . 53
- stopping, parking . . . . . 63
- turning on slopes . . . . . 59
- uphill . . . . . 58

**S****Seat**

- mounting . . . . . 97
- removing . . . . . 97

**Service . . . . . 8****Service schedule . . . . . 66-69****Shift lever**

- basic position, adjusting . . . . . 171
- basic setting, checking . . . . . 171

**Shifting**

- forward gears . . . . . 54

**Spare parts . . . . . 8****Speedometer**

- adjusting . . . . . 30
- clock, setting . . . . . 29
- function description . . . . . 27
- kilometers or miles, setting . . . . . 28

**Starting . . . . . 51**

<b>Steering</b>	
locking	46
unlocking	46
<b>Stopping</b>	63
<b>Storage</b>	184
<b>T</b>	
<b>Technical data</b>	
carburetor	196
chassis	197-200
chassis tightening torques	205-206
engine	191-192
engine tightening torques	193-195
front shock absorber	201-202
rear shock absorber	203-204
<b>Throttle cable routing</b>	
checking	123
<b>Throttle lever</b>	22
<b>Tire air pressure</b>	
checking	148
<b>Tire condition</b>	
checking	147
<b>Toe</b>	
adjusting	109
checking	106
<b>Transport</b>	9
<b>Troubleshooting</b>	186-190

<b>Turn signal switch</b>	23
<b>Type label</b>	16
<b>U</b>	
<b>Use definition</b>	8
<b>V</b>	
<b>Vehicle</b>	
cleaning	182
lifting gear, raising with	88
lifting gear, removing from	88
<b>W</b>	
<b>Wheel/wheels</b>	
installing	146
removing	146
<b>Work rules</b>	9



3211604en



06/2010 Photo: Mitterbauer



**KTM-Sportmotorcycle AG**  
5230 Mattighofen/Austria  
<http://www.ktm.com>