

SETUP INSTRUCTIONS 2011

525 XC ATV EU

Art. no. 3211683en



KTM

The work described in these setup instructions must be performed before the vehicle is delivered to the customer.

Read the setup instructions in their entirety before beginning work.

Print out the current **PDI** form found on the **KTM DEALER.NET**.

These setup instructions were written to correspond to the latest state of this series. We reserve the right to make changes in the interest of technical advancement without at the same time updating this manual.

We shall not provide a description of general workshop methods. Likewise, safety rules that apply in a workshop are not specified here. It is assumed that the work will be performed by a fully trained mechanic.

All specifications are non-binding. KTM Sportmotorcycle AG in particular reserves the right to modify or delete technical specifications, prices, colors, forms, materials, services, designs, equipment, etc., without prior notice and without specifying reasons, to adapt these to local conditions, as well as to stop production of a particular model without prior notice. KTM accepts no liability for delivery options, deviations from illustrations and descriptions, as well as misprints and other errors. The models portrayed partly contain special equipment that does not belong to the regular scope of delivery.

© 2010 KTM-Sportmotorcycle AG, Mattighofen Austria

All rights reserved

Reproduction, even in part, as well as copying of all kinds, is permitted only with the express written permission of the copyright owner.



REG.NO. 12 100 6061

ISO 9001(12 100 6061)

According to the international quality management standard ISO 9001, KTM uses quality assurance processes that lead to the maximum possible quality of the products.

Issued by: TÜV Management Service

KTM-Sportmotorcycle AG
5230 Mattighofen, Austria

Symbols used

The symbols used are explained in the following.



Indicates an expected reaction (e.g. of a work step or a function).



Indicates an unexpected reaction (e.g. of a work step or a function).



Identifies a page reference (more information is provided on the specified page).



Denotes additional information or tips.



Denotes the result of a test step.



Denotes a voltage measurement.



Denotes a current measurement.



Denotes a resistance measurement.

Formats used

The typographical and other formats used are explained in the following.

Proprietary name	Identifies a proprietary name.
Name[®]	Identifies a protected name.
Brand[™]	Identifies a brand in merchandise traffic.

Unpacking and setting up the vehicle



- Remove the box and the plastic packaging.
- Carefully release and remove the tension belts from the vehicle.
 - ✓ The vehicle rebounds.
- Remove the vehicle from the palette.
- Check the vehicle for transport damage.
- Unpack the separate enclosure and check its contents on the basis of the enclosure list.



Warning

Risk of injury Battery acid and battery gases cause serious cauterization.

- Keep batteries out of the reach of children.
- Wear suitable protective clothing and goggles.
- Avoid contact with battery acid and battery gases.
- Keep the battery away from sparks or open fire. Charge only in well ventilated rooms.
- Flush with copious amounts of water in case of skin contact. If battery acid comes into contact with the eyes, flush the eyes with water for at least 15 minutes and consult a physician.

- Fill the battery.



Info

Read the notes in the battery package.

- Recharge the battery. (☛ p. 7)
- Install the battery. (☛ p. 8)
- Fill up with fuel. (☛ p. 8)

Operation with reverse gear (on request only)



Danger

Voiding of the government approval for road use and the insurance coverage The vehicle is only authorized for operation on public roads in the homologated version.

- If the vehicle is modified in any way, it may only be used on designated tracks away from public roads. Advise the vehicle owner and rider of this.
- If you undertake any modifications, please insist on receiving a signed workshop order from your customer in which you inform the customer in writing that these modifications are performed at the customer's own risk and that the vehicle will no longer be approved for use on public roads once modified.

- Attach the reverse gear cable.
- Move the handlebar to the straight-ahead position.
- Release nut ① and use screw ② to adjust the play of cable A on the reverse gear release lever.

Guideline

Play in the Bowden cable on the reverse gear release lever	10 mm (0.39 in)
--	-----------------

- Tighten nut ①.
- Insert ignition key ① in the key cover cap ②.



Info

The key cover cap is in the tool set.
Read the installation instructions inside the cap.

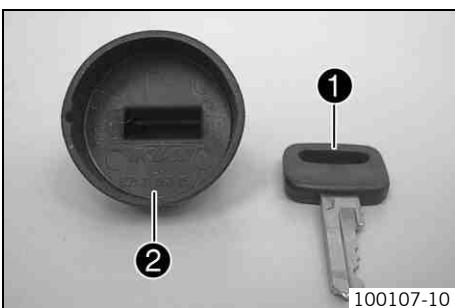
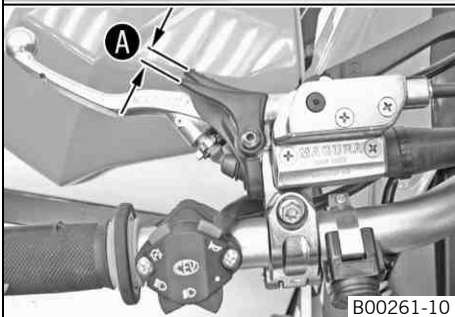
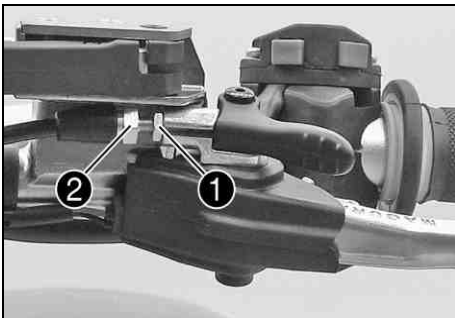



- Mount and tighten the rear mirror adapter and rear mirror on both sides.
- Mount all controls on the handlebar in their exact positions. Tighten all screws.
- Set kilometers or miles. (☛ p. 6)

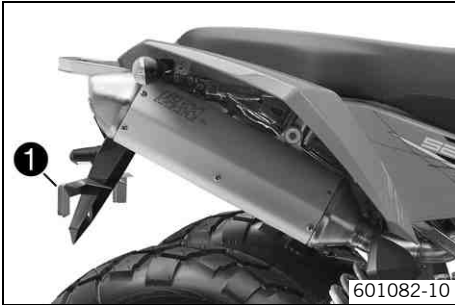

- Bond the reflectors on the right and left and mount the holder for reflector ❶ on the upper screws of the license plate holder.
- Unpack and mount the **KTM PowerParts** included in the delivery (optional).



Info

Read the accompanying **KTM PowerParts** installation instructions.

- Apply the label included in the delivery (optional).
- Print out the current **PDI** form found on **KTM DEALER.NET** and perform the delivery inspection.

Removing the seat

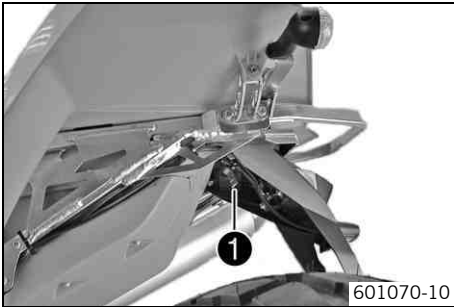

- Pull the release hook ❶ back. Lift up the seat at the rear, pull it back and then remove from above.

Mounting the seat

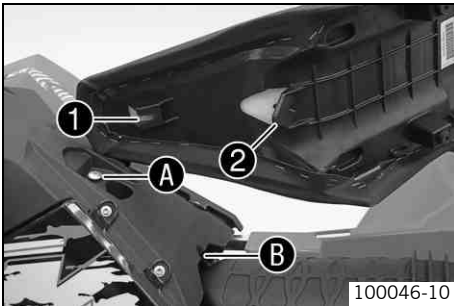

- Hook slot ❶ on the seat into collar sleeve ❸ of the fuel tank, lower the rear of the seat and slide tab ❷ under fuel tank ❹.

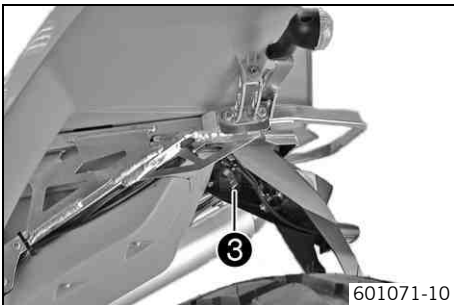

- Push down the rear of the seat until release hook ❸ engages.
- Make sure that the seat is correctly locked in.

Removing the rear fender

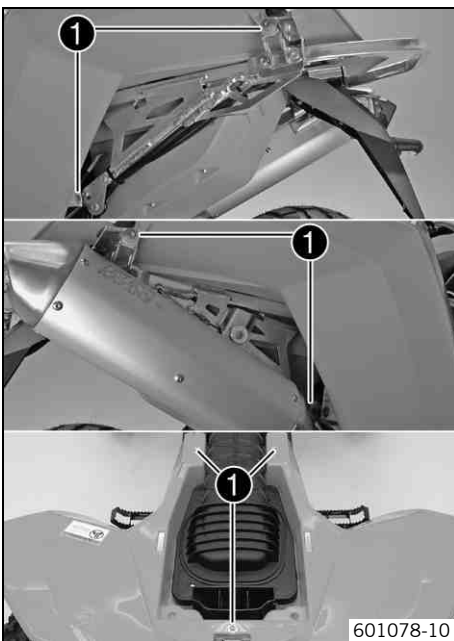

- Remove the seat (☛ p. 5)
- Remove screws ❶.

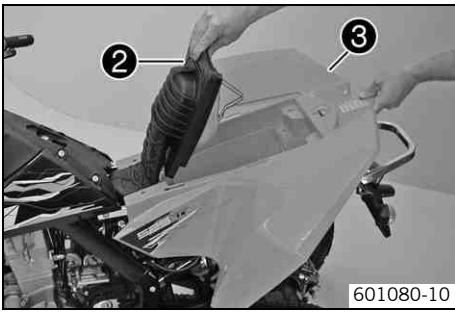

- Raise the rear of the air filter box lid ②. At the same time, use your other hand to press on the carburetor connection boot to kink it at that location.



Info

This prevents the carburetor connection boot from disconnecting from the carburetor.

- Raise fender ③ at the rear and remove it.

Installing the rear fender

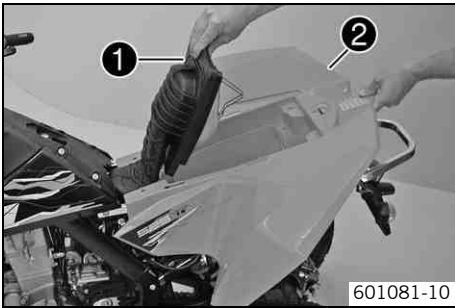

- Raise the rear of the air filter box lid ①. At the same time, use your other hand to press on the carburetor connection boot to kink it at that location.



Info

This prevents the carburetor connection boot from disconnecting from the carburetor.

- Position front fender ②.
- Fix the air filter box lid in the fender.



Info

If the air filter box lid is not correctly mounted, dust and dirt can penetrate into the engine and cause damage.

- Mount and tighten screws ③.

Guideline

Remaining screws, chassis	M6	10 Nm (7.4 lbf ft)
---------------------------	----	--------------------

- Mount the seat. (☛ p. 5)

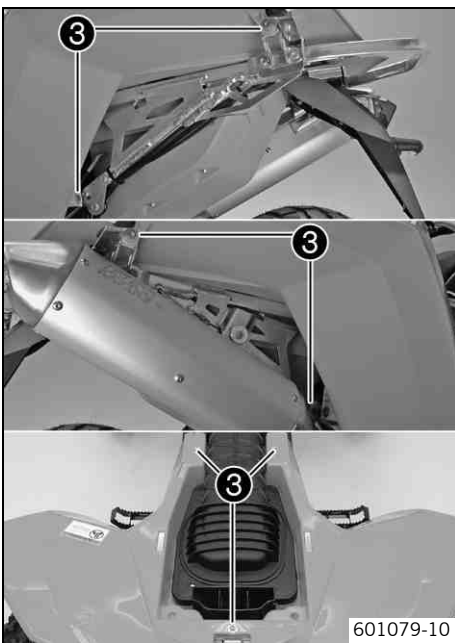

Setting kilometers or miles







Info

If you change the unit of measure, the **ODO** value is retained and converted accordingly. The values **TR1**, **TR2**, **A1**, **A2** and **S1** are cleared when the unit of measure is changed.

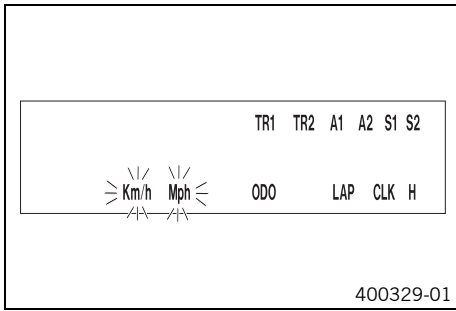
Condition

The vehicle is stationary.





- Press the button  briefly and repeatedly until **H** appears at the bottom right of the display.
- Press the button  for 3 - 5 seconds.
 - ✓ The Setup menu is displayed and the active functions are shown.
- Press the button  repeatedly until the **Km/h/Mph** display flashes.

Adjusting Km/h

- Press the button .

Adjusting Mph

- Press the button .
- Press the button  for 3 - 5 seconds.
 - ✓ The settings are stored and the Setup menu is closed.

 **Info**

If no button is pressed for 20 seconds, or if no impulse comes from the wheel speed sensor, the settings are automatically saved and the Setup menu is closed.

Recharging the battery

 **Warning**

Risk of injury Battery acid and battery gases cause serious cauterization.

- Keep batteries out of the reach of children.
- Wear suitable protective clothing and goggles.
- Avoid contact with battery acid and battery gases.
- Keep the battery away from sparks or open fire. Charge only in well ventilated rooms.
- Flush with copious amounts of water in case of skin contact. If battery acid comes into contact with the eyes, flush the eyes with water for at least 15 minutes and consult a physician.

 **Warning**

Environmental hazard Battery parts and acid are harmful to the environment.

- Do not discard batteries with the household trash. Dispose of a defective battery in an environmentally compatible manner. Give the battery to your KTM dealer or to a recycling center that accepts used batteries.

 **Warning**

Environmental hazard Hazardous substances cause environmental damage.

- Oil, grease, filters, fuel, cleaners, brake fluid, etc., should be disposed of as stipulated in applicable regulations.

 **Info**

Even if there is no load on the battery, it still loses power steadily. The charge state and the type of charge are very important for the service life of the battery. Rapid charging with a high charging current has a negative impact on the service life. If the charging current, charging voltage and charging time are exceeded, electrolyte escapes via the safety valves. This reduces the battery capacity. If the vehicle is started repeatedly until the battery is depleted, the battery must be charged immediately. If the battery is left in a discharged state for an extended period, it will drain completely and sulfate, destroying the battery. The battery is maintenance-free, which means that the acid level does not need to be checked.

- Switch off all power consumers and switch off the engine.
- Remove the rear fender. (🔧 p. 5)
- Disconnect the minus (negative) cable of the battery to avoid damage to the vehicle's electronics.



- Connect the battery charger to the battery. Switch on the battery charger.

Battery charger (58429074000)

In addition, this battery charger can be used to test the open-circuit current, the start ability of the battery and the alternator. With this device, you cannot over-charge the battery.



Info

- Never remove the lid ❶.
- Charge the battery to a maximum of 10% of the capacity specified on the battery housing ❷.

- Switch off the charger after charging. Disconnect the battery.

Guideline

The charge current, charge voltage and charge time must not be exceeded.

Charge the battery regularly when the vehicle is not in use	3 months
---	----------

- Install the rear fender. (☛ p. 6)

Installing the battery

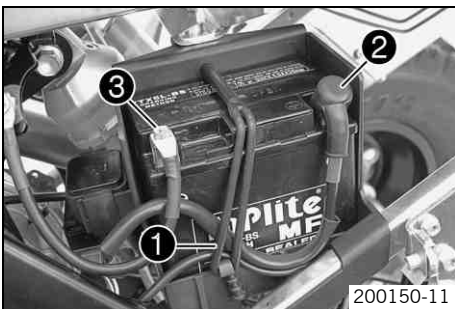

- Place the battery in the battery holder.

Battery (YTX5L-BS)

- Reconnect rubber band ❶.
- Attach the positive (plus) cable and replace the plus pole cover ❷.
- Connect the negative (minus) cable ❸ of the battery.
- Install the rear fender. (☛ p. 6)

Refueling



Danger

Fire hazard Fuel is highly flammable.

- Never refuel the vehicle near open flames or burning cigarettes, and always switch off the engine first. Be careful that no fuel is spilt, especially on hot vehicle components. Clean up spilt fuel immediately.
- Fuel in the fuel tank expands when warm and can escape if the tank is overfilled. See the notes on refueling.



Warning

Danger of poisoning Fuel is poisonous and a health hazard.

- Avoid contact of the fuel with skin, eyes and clothing. Do not inhale fuel vapors. If fuel gets into your eyes, rinse immediately with water and contact a doctor. Wash affected skin areas immediately with soap and water. If fuel is swallowed, contact a doctor immediately. Change clothing that has come into contact with fuel.



Warning

Environmental hazard Improper handling of fuel is a danger to the environment.

- Do not allow fuel to get into the ground water, the ground, or the sewage system.

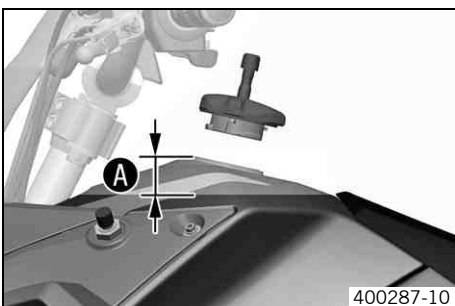

- Switch off the engine.
- Open the filler cap.
- Fill the fuel tank with fuel up to measurement ❶.

Guideline

Measurement of ❶	35 mm (1.38 in)	
Total fuel tank capacity approx.	13.5 l (3.57 US gal)	Super unleaded (ROZ 95 / RON 95 / PON 91) (☛ p. 11)

- Close the filler cap.

Remaining nuts, chassis	M6	15 Nm (11.1 lbf ft)	–
Remaining screws, chassis	M6	10 Nm (7.4 lbf ft)	–
Screw on fuel tank	M6	6 Nm (4.4 lbf ft)	–
Screw, clamping nut, rear axle	M6	10 Nm (7.4 lbf ft)	–
Screw, foot brake cylinder	M6	7 Nm (5.2 lbf ft)	Loctite® 243™
Screw, rear brake caliper	M6	10 Nm (7.4 lbf ft)	Loctite® 243™
Remaining nuts, chassis	M8	30 Nm (22.1 lbf ft)	–
Remaining screws, chassis	M8	25 Nm (18.4 lbf ft)	–
Screw, bearing support, steering	M8	25 Nm (18.4 lbf ft)	–
Screw, front brake caliper	M8	20 Nm (14.8 lbf ft)	Loctite® 243™
Screw, front brake disc	M8	25 Nm (18.4 lbf ft)	Loctite® 243™
Screw, handlebar clamp	M8	20 Nm (14.8 lbf ft)	–
Screw, rear brake caliper	M8	20 Nm (14.8 lbf ft)	Loctite® 243™
Screw, rear brake disc	M8	25 Nm (18.4 lbf ft)	Loctite® 243™
Screw, rear wheel eccentric element	M8	20 Nm (14.8 lbf ft)	–
Screw, steering bridge	M8	20 Nm (14.8 lbf ft)	–
Screw, subframe	M8	35 Nm (25.8 lbf ft)	Loctite® 243™
Engine bracket screw	M10	60 Nm (44.3 lbf ft)	–
Engine mounting bolt	M10	60 Nm (44.3 lbf ft)	–
Nut, handlebar support	M10	45 Nm (33.2 lbf ft)	–
Remaining nuts, chassis	M10	50 Nm (36.9 lbf ft)	–
Remaining screws, chassis	M10	45 Nm (33.2 lbf ft)	–
Screw, A-arm bottom	M10x70	45 Nm (33.2 lbf ft)	–
Screw, A-arm top	M10x52	45 Nm (33.2 lbf ft)	–
Screw, footrest	M10	45 Nm (33.2 lbf ft)	–
Screw, front shock absorber	M10	45 Nm (33.2 lbf ft)	–
Screw, steering column at bottom of steering lever	M10	25 Nm (18.4 lbf ft)	–
Nut, ball head, A-arm top	M10x1.25	35 Nm (25.8 lbf ft)	–
Nut, rear sprocket screw	M10x1.25	45 Nm (33.2 lbf ft)	Loctite® 243™
Nut, tie rod end	M10x1.25	45 Nm (33.2 lbf ft)	–
Wheel nut	M10x1.25	45 Nm (33.2 lbf ft)	–
Nut, front wheel hub	M12	70 Nm (51.6 lbf ft)	–
Screw, rear bottom shock absorber	M12	70 Nm (51.6 lbf ft)	–
Screw, rear top shock absorber	M12	60 Nm (44.3 lbf ft)	–
Lock nut, tie rod, inside	M12LHx1.25	20 Nm (14.8 lbf ft)	–
Lock nut, tie rod, outside	M12x1.25	20 Nm (14.8 lbf ft)	–
Nut, A-arm top	M12x1.25	30 Nm (22.1 lbf ft)	–
Nut, ball head, A-arm bottom	M12x1.5	40 Nm (29.5 lbf ft)	–
Nut, swingarm pivot	M16x1.5	100 Nm (73.8 lbf ft)	–
Nut, rear wheel hub	M18x1.5	130 Nm (95.9 lbf ft)	–
Screw, steering column, bottom	M20x1.5	40 Nm (29.5 lbf ft)	–
Screw, steering column, top	M20x1.5	25 Nm (18.4 lbf ft)	–
Clamping nut, rear axle	2"-10UNS-2B-LH	25 Nm (18.4 lbf ft)	Only applies when using: Open-end wrench attachment, 46 mm (83019010461)

Super unleaded (ROZ 95 / RON 95 / PON 91)

According to

- DIN EN 228 (ROZ 95 / RON 95 / PON 91)



3211683en



09/2010 Photo: Mitterbauer



KTM-Sportmotorcycle AG
5230 Mattighofen/Austria
<http://www.ktm.com>