

OWNER'S MANUAL 2011



125 EXC EU

125 EXC Factory Edition EU

125 EXC SIX DAYS EU

200 EXC EU

200 EXC AUS

200 XC-W USA

250 EXC EU

250 EXC Factory Edition EU

250 EXC AUS

250 EXC SIX DAYS EU

250 XC-W USA

300 EXC EU

300 EXC Factory Edition EU

300 EXC AUS

300 EXC SIX DAYS EU

300 XC-W USA

Art. no. 3211688en

The KTM logo, consisting of the letters 'KTM' in a bold, italicized, sans-serif font, is positioned in the bottom right corner of the page against an orange background.

Congratulations on your decision to purchase a KTM motorcycle. You are now the owner of a state-of-the-art sports motorcycle that will give you enormous pleasure if you service and maintain it accordingly.

We wish you a lot of enjoyment in riding this vehicle.

Enter the serial numbers of your vehicle below.

Chassis number (☛ p. 10)	Dealer's stamp
Engine number (☛ p. 11)	
Key number (EXC, EXC Factory Edition, EXC SIX DAYS) (☛ p. 10)	

The owner's manual corresponded to the latest state of this series at the time of printing. Slight deviations resulting from continuing development and design can, however, not be completely excluded.

All specifications are non-binding. KTM Sportmotorcycle AG specifically reserves the right to modify or delete technical specifications, prices, colors, forms, materials, services, designs, equipment, etc., without prior notice and without specifying reasons, to adapt these to local conditions, as well as to stop production of a particular model without prior notice. KTM accepts no liability for delivery options, deviations from illustrations and descriptions, as well as misprints and other errors. The models portrayed partly contain special equipment that does not belong to the regular scope of delivery.

© 2010 KTM-Sportmotorcycle AG, Mattighofen Austria

All rights reserved

Reproduction, even in part, as well as copying of all kinds, is permitted only with the express written permission of the copyright owner.















ISO 9001(12 100 6061)





































According to the international quality management standard ISO 9001, KTM uses quality assurance processes that lead to the maximum possible quality of the products.





Issued by: TÜV Management Service

REG.NO. 12 100 6061

KTM-Sportmotorcycle AG
5230 Mattighofen, Austria





MEANS OF REPRESENTATION	5	Unlocking the steering (EXC, EXC Factory Edition, EXC SIX DAYS)	25
IMPORTANT INFORMATION	6	PUTTING INTO OPERATION.....	26
VIEW OF VEHICLE.....	8	Advice on first use.....	26
View of the vehicle from the left front (example)	8	Running in the engine.....	27
View of the vehicle from the right rear (example)	9	Preparing the vehicle for difficult operating conditions	27
SERIAL NUMBERS.....	10	Preparations for riding on dry sand	27
Chassis number.....	10	Preparations for riding on wet sand	28
Type label.....	10	Preparations for riding on wet and muddy surfaces	29
Key number (EXC, EXC Factory Edition, EXC SIX DAYS)	10	Preparations for riding at high temperatures and low speeds.....	30
Engine number.....	11	Preparations for riding at low temperatures and in snow	30
Fork part number.....	11	RIDING INSTRUCTIONS	31
Shock absorber part number	11	Checks and maintenance work when preparing for use	31
CONTROLS	12	Starting	31
Clutch lever	12	Starting up	32
Choke (EXC EU, EXC SIX DAYS, EXC Factory Edition)	12	Shifting, riding.....	32
Hand brake lever	12	Braking	32
Throttle grip.....	12	Stopping, parking.....	33
Short circuit button (EXC, EXC Factory Edition, EXC SIX DAYS)	13	Refueling.....	33
Short circuit button (XC-W)	13	SERVICE SCHEDULE.....	35
Light switch (EXC, EXC Factory Edition, EXC SIX DAYS)	13	Service schedule	35
Turn signal switch (EXC, EXC Factory Edition, EXC SIX DAYS)	13	Maintenance work (as an additional order)	36
Horn button (EXC, EXC Factory Edition, EXC SIX DAYS)	13	TUNING THE CHASSIS.....	37
Emergency OFF switch (200 EXC AUS)	14	Checking the basic chassis setting with the rider's weight	37
Emergency OFF switch (250/300 EXC AUS)	14	Compression damping of shock absorber.....	37
Electric starter button (All 250/300 EXC EU models, 250/300 XC-W).....	14	Adjusting the high-speed compression damping of the shock absorber	37
Electric starter button (250/300 EXC AUS).....	14	Adjusting the low-speed compression damping of the shock absorber	38
Light switch (XC-W)	14	Adjusting the rebound damping of the shock absorber.....	38
Overview of indicator lamps (EXC, EXC Factory Edition, EXC SIX DAYS)	15	Measuring the sag of the unloaded rear wheel	39
Speedometer.....	15	Checking the static sag of the shock absorber	39
Speedometer activation and test	15	Checking the riding sag of the shock absorber	40
Tripmaster switch	15	Adjusting the spring preload of the shock absorber 	40
Setting kilometers or miles	16	Adjusting the riding sag 	41
Setting the clock.....	16	Checking the basic setting of the fork.....	41
Adjusting the speedometer functions.....	17	Adjusting the compression damping of the fork	41
Querying the lap time	17	Adjusting the rebound damping of the fork.....	42
Display mode SPEED (speed)	18	Adjusting the spring preload of the fork	43
Display mode SPEED/H (service hours)	18	Handlebar position	43
Display mode SPEED/CLK (clock)	18	Adjusting the handlebar position 	43
Display mode SPEED/LAP (lap time)	18	MAINTENANCE WORK ON THE CHASSIS	45
Display mode SPEED/ODO (odometer)	19	Raising the motorcycle with the lift stand	45
Display mode SPEED/TR1 (trip master 1)	19	Removing the motorcycle from the lift stand	45
Display mode SPEED/TR2 (trip master 2)	19	Bleeding the fork legs	45
Display mode SPEED/A1 (average speed 1).....	20	Cleaning the dust boots of the fork legs	46
Display mode SPEED/A2 (average speed 2).....	20	Loosening the fork protection.....	46
Display mode SPEED/S1 (stop watch 1)	20	Positioning the fork protection	46
Display mode SPEED/S2 (stop watch 2)	20	Removing the fork legs 	46
Fuel tap.....	22	Installing the fork legs 	47
Opening the filler cap	22	Removing the fork protector 	48
Closing the filler cap.....	23	Installing the fork protector 	48
Choke (EXC AUS, XC-W).....	23	Removing the lower triple clamp  (EXC EU/AUS).....	48
Shift lever.....	23	Removing the lower triple clamp  (EXC SIX DAYS, EXC Factory Edition, XC-W)	49
Kickstarter	23	Installing the lower triple clamp  (EXC EU/AUS)	49
Foot brake lever.....	24	Installing the lower triple clamp  (EXC SIX DAYS, EXC Factory Edition, XC-W)	51
Side stand	24	Checking the play of the steering head bearing.....	53
Steering lock (EXC, EXC Factory Edition, EXC SIX DAYS)	24	Adjusting the play of the steering head bearing 	53
Locking the steering (EXC, EXC Factory Edition, EXC SIX DAYS)	24		

Greasing the steering head bearing 	54	Recharging the battery  (All 250/300 models)	83
Removing the start number plate (XC-W)	54	Removing the main fuse (All 250/300 models)	84
Installing the start number plate (XC-W)	54	Installing the main fuse (All 250/300 models)	84
Removing the front fender	54	Removing the headlight mask with the headlight (EXC, EXC Factory Edition, EXC SIX DAYS)	85
Installing the front fender	55	Refitting the headlight mask with the headlight (EXC, EXC Factory Edition, EXC SIX DAYS)	85
Removing the shock absorber 	55	Changing the headlight bulb (EXC, EXC Factory Edition, EXC SIX DAYS)	86
Installing the shock absorber 	55	Checking the headlight setting (EXC, EXC Factory Edition, EXC SIX DAYS)	86
Removing the seat	56	Adjusting the headlight range (EXC, EXC Factory Edition, EXC SIX DAYS)	87
Mounting the seat	56	Changing the speedometer battery	87
Removing the air filter box lid	57	COOLING SYSTEM	88
Installing the air filter box lid	57	Cooling system	88
Removing the air filter 	57	Checking the antifreeze and coolant level	88
Installing the air filter 	57	Checking the coolant level	89
Cleaning the air filter and air filter box 	58	Draining the coolant 	89
Removing the main silencer	58	Refilling with coolant 	90
Installing the main silencer	59	TUNING THE ENGINE	92
Changing the glass fiber yarn filling of the main silencer 	59	Checking the play in the throttle cable	92
Removing the fuel tank 	59	Adjusting the play in the throttle cable 	92
Installing the fuel tank 	60	Carburetor	92
Checking the chain for dirt	61	Carburetor - adjusting the idle speed 	93
Cleaning the chain	61	Emptying the carburetor float chamber 	94
Checking the chain tension	62	Checking the basic position of the shift lever	94
Checking the chain, rear sprocket, engine sprocket and chain guide	62	Adjusting the basic position of the shift lever 	94
Adjusting the chain tension	64	Engine characteristic - auxiliary spring (All 250/300 models)	95
Adjusting the chain guide 	65	Engine characteristic - adjusting the auxiliary spring 	95
Checking the throttle cable routing	65	(All 250/300 models)	95
Adjusting the basic position of the clutch lever	66	MAINTENANCE WORK ON THE ENGINE	97
Checking the fluid level of the hydraulic clutch	66	Checking the gear oil level	97
Changing the hydraulic clutch fluid 	67	Changing the gear oil 	97
BRAKES	69	Draining the gear oil 	98
Checking free travel of hand brake lever	69	Refilling with gear oil 	98
Adjusting the basic position of the hand brake lever (XC-W)	69	Adding gear oil 	99
Adjusting free travel of hand brake lever (EXC, EXC Factory Edition, EXC SIX DAYS)	69	CLEANING, CARE	100
Checking the brake discs	70	Cleaning the motorcycle	100
Checking the front brake fluid level	70	Protection for winter operation	101
Adding front brake fluid 	70	STORAGE	102
Checking the front brake linings	71	Storage	102
Changing the front brake linings 	72	Putting into operation after storage	102
Checking free travel of foot brake lever	73	TROUBLESHOOTING	103
Adjusting basic position of foot brake lever 	73	TECHNICAL DATA - ENGINE	105
Checking the rear brake fluid level	74	All 125 models	105
Adding brake fluid for the rear brake 	74	All 200 models	105
Checking the rear brake linings	75	All 250 models	106
Removing the rear brake linings 	75	All 300 models	106
Installing the rear brake linings 	76	Capacity - transmission oil	107
Changing the rear brake linings 	76	Capacity - coolant	107
WHEELS, TIRES	78	TECHNICAL DATA - ENGINE TIGHTENING TORQUES	108
Removing the front wheel 	78	All 125/200 models	108
Installing the front wheel 	78	All 250/300 models	108
Removing the rear wheel 	79	TECHNICAL DATA - CARBURETOR	110
Installing the rear wheel 	79	All 125 models	110
Checking the tire condition	80	200 EXC EU	110
Checking the tire air pressure	81	200 EXC AUS	110
Checking the spoke tension	81	200 XC-W USA	110
ELECTRICAL SYSTEM	83	All 250 EXC EU models	111
Removing the battery  (All 250/300 models)	83	250 EXC AUS	111
Installing the battery  (All 250/300 models)	83		

250 XC-W USA	111
All 300 EXC EU models	111
300 EXC AUS	112
300 XC-W USA	112
Carburetor configuration (All 125 models) 	112
Carburetor configuration (All 200 models) 	114
Carburetor configuration (All 250 models) 	115
Carburetor configuration (All 300 models) 	116
General carburetor configuration 	117
TECHNICAL DATA - CHASSIS	118
Lighting equipment	119
Tires	119
Capacity - fuel.....	119
TECHNICAL DATA - FORK.....	120
All 125/200 models	120
All 250/300 models	120
TECHNICAL DATA - SHOCK ABSORBER	122
All 125/200 models	122
All 250/300 models	122
TECHNICAL DATA - CHASSIS TIGHTENING TORQUES	124
SUBSTANCES.....	125
AUXILIARY SUBSTANCES.....	127
STANDARDS.....	129
INDEX	130

Symbols used

The symbols used are explained below.

-
- | | |
|--|---|
|  | Indicates an expected reaction (e.g., to a work step or a function). |
|  | Indicates an unexpected reaction (e.g., to a work step or a function). |
|  | All work marked with this symbol requires specialist knowledge and technical understanding. In the interest of your own safety, have these jobs done in an authorized KTM workshop! There, your motorcycle will be serviced optimally by specially trained experts using the specialist tools required. |
|  | Identifies a page reference (more information is provided on the specified page). |
-

Formats used

The typographical and other formats used are explained below.

-
- | | |
|--------------------------|--|
| Specific name | Identifies a specific name. |
| Name[®] | Identifies a protected name. |
| Brand[™] | Identifies a brand available on the open market. |
-

Use definition (EXC, EXC Factory Edition, EXC SIX DAYS)

KTM sport motorcycles are designed and built to withstand the normal stresses and strains of competitive use. The motorcycles comply with currently valid regulations and categories of the top international motorsport organizations.

Info

The motorcycle is authorized for public road traffic in the homologous (reduced) version only. In the derestricted version, the motorcycle must be used only on closed off property remote from public road traffic. The motorcycle is designed for offroad sport endurance competition (Enduro) and not for predominant motocross use.

Use definition (XC-W)

KTM sport motorcycles are designed and built to withstand the normal stresses and strains of competitive use. The motorcycles comply with currently valid regulations and categories of the top international motorsport organizations.

Info

The motorcycle must be used only on closed off property remote from public road traffic. The motorcycle is designed for offroad sport endurance competition (Enduro) and not for predominant motocross use.

Service

A prerequisite for perfect operation and prevention of wear is that the engine and chassis service, care and adjustment work described in the owner's manual is properly carried out. Poor adjustment and tuning of the engine and chassis can lead to damage and breakage of components.

Using the motorcycle in difficult conditions such as on sand or very muddy or wet terrain can lead to above-average wear of components such as the transmission train or the brakes. For this reason, it may be necessary to service or replace worn parts before the limit specified in the service schedule is reached.

Pay careful attention to the prescribed running-in period and service intervals. If you observe these exactly, you will ensure a much longer service life for your motorcycle.

Warranty

The work prescribed in the service schedule must be carried out in an authorized KTM workshop only and confirmed in the customer's service record, since otherwise no warranty claims will be honored. No warranty claims can be considered for damage resulting from manipulations and/or alterations to the vehicle.

Fuel, oils, etc.

You should use the fuels, oils and greases according to specifications as listed in the owner's manual.

Spare parts, accessories

For your own safety, only use spare parts and accessory products that have been approved and/or recommended by KTM and have them installed by an authorized KTM workshop. KTM accepts no liability for other products and any resulting damage or loss. Certain spare parts and accessories are specified in parentheses in the descriptions. Your KTM dealer will be glad to advise you.

You will find the current **KTM PowerParts** for your vehicle on the KTM website.

International KTM Website: <http://www.ktm.com>

Work rules

Special tools are needed for certain tasks. They are not included with the vehicle but can be ordered under the number in parentheses. E.g.: bearing puller (15112017000)

When the vehicle is assembled, non-reusable parts (e.g., self-locking screws and nuts, gaskets, seal rings, O-rings, splints, lock washers) must be replaced with new parts.

Where thread lockers are used on screw connections (e.g., **Loctite**®), follow the instructions for use from the manufacturer.

After disassembly, clean the parts that are to be reused and check them for damage and wear. Replace damaged or worn parts.

After you complete the repair or maintenance work, check the roadworthiness of the vehicle.

Transport

Note

Danger of damage The parked vehicle may roll away or fall over.

- Always place the vehicle on a firm and even surface.

Note

Fire hazard Some vehicle components become very hot when the vehicle is operated.

- Do not park the vehicle near flammable or explosive substances. Do not place objects on the vehicle while it is still warm from being run. Always let the vehicle cool first.
-
- Switch off the engine.
 - Turn handle ❶ of the fuel tap to the **OFF** position.
 - Use straps or other suitable devices to secure the motorcycle against accidents or falling over.

Environment

Motorcycling is a wonderful sport and we naturally hope that you can enjoy it to the full. However, it is a potential problem for the environment and can lead to conflicts with other persons. But if you use your motorcycle responsibly, you can ensure that such problems and conflicts do not have to occur. To protect the future of motorcycle sport, make sure that you use your motorcycle legally, display environmental consciousness, and respect the rights of others.

Notes/warnings

Pay close attention to the notes/warnings.



Info

Various information and warning labels are affixed to the vehicle. Do not remove information/warning labels. If they are missing, you or others may not recognize potential hazards and may therefore be injured.

Grades of risks



Danger

Identifies a danger that will immediately and invariably lead to fatal or serious permanent injury if the appropriate measures are not taken.



Warning

Identifies a danger that is likely to lead to fatal or serious injury if the appropriate measures are not taken.



Caution

Identifies a danger that may lead to minor injuries if the appropriate measures are not taken.

Note

Identifies a danger that will lead to considerable machine and material damage if the appropriate measures are not taken.



Warning

Identifies a danger that will lead to environmental damage if the appropriate measures are not taken.

Owner's manual

- It is important that you read this owner's manual carefully and completely before making your first trip. It contains information and tips that will assist you in operating and handling your motorcycle properly. Only then will you learn how to adjust the motorcycle to your own requirements and how to protect yourself from injury. The owner's manual also contains important information on servicing the motorcycle.
- The owner's manual is an important component of the motorcycle and should be handed over to the new owner if the vehicle is sold.

View of the vehicle from the left front (example)



601153-01

- | | |
|---|----------------------|
| 1 | Hand brake lever |
| 2 | Short circuit button |
| 3 | Clutch lever |
| 4 | Air filter box lid |
| 5 | Fuel tap |
| 6 | Shift lever |
| 7 | Chain guide |
| 8 | Side stand |

View of the vehicle from the right rear (example)



601154-10

- | | |
|---|------------------------------------|
| 1 | Shock absorber rebound adjustment |
| 2 | Level viewer for brake fluid, rear |
| 3 | Foot brake lever |
| 4 | Kickstarter |
| 5 | Bleeder screw, fork leg |
| 6 | Throttle grip |
| 7 | Chassis number |
| 8 | Filler cap |

Chassis number



(XC-W)

The chassis number ❶ is stamped on the right side of the steering head.

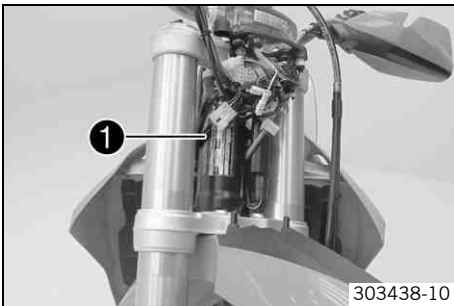

(EXC, EXC Factory Edition, EXC SIX DAYS)

The chassis number ❶ is stamped on the right side of the steering head.

Type label



(XC-W)

The type label ❶ is fixed to the front of the steering head.

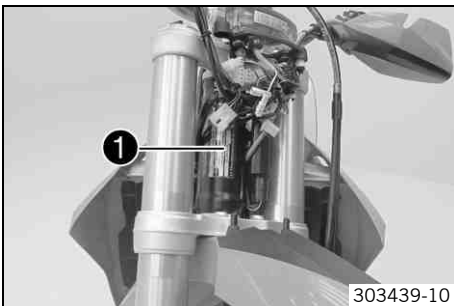

(EXC, EXC Factory Edition, EXC SIX DAYS)

The type label ❶ is fixed to the front of the steering head.

Key number (EXC, EXC Factory Edition, EXC SIX DAYS)

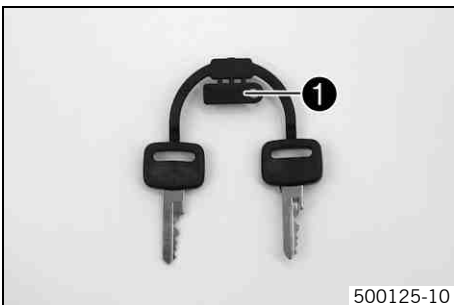

The key number ❶ for the steering lock is stamped onto the key connector.

Engine number

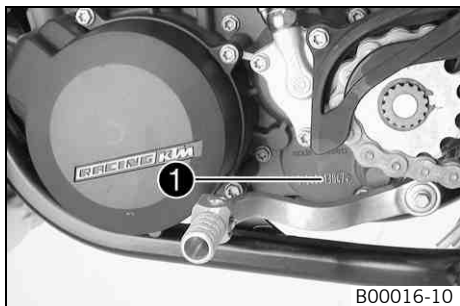

The engine number ❶ is stamped on the left side of the engine under the engine sprocket.

Fork part number

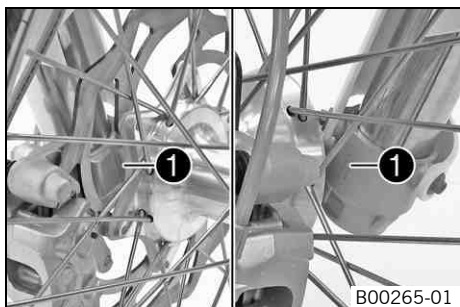

The fork part number ❶ is stamped on the inner side of the fork stub.

Shock absorber part number



The shock absorber part number ❶ is stamped on the top of the shock absorber above the adjusting ring on the engine side.

Clutch lever

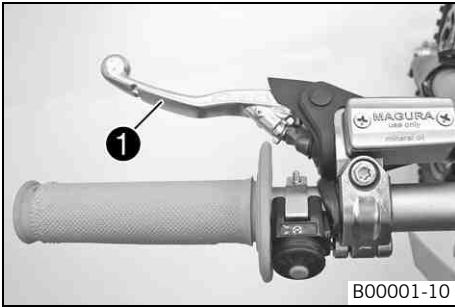

(All 125/200 models)

The clutch lever ❶ is fitted on the left side of the handlebar.
The clutch is hydraulically operated and self-adjusting.

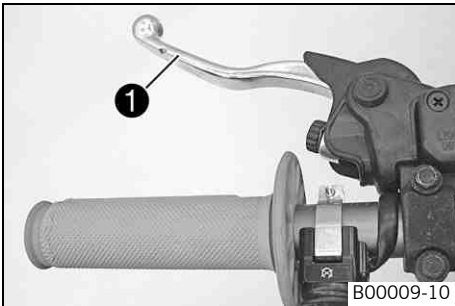

(All 250/300 models)

The clutch lever ❶ is fitted on the left side of the handlebar.
The clutch is hydraulically operated and self-adjusting.

Choke (EXC EU, EXC SIX DAYS, EXC Factory Edition)

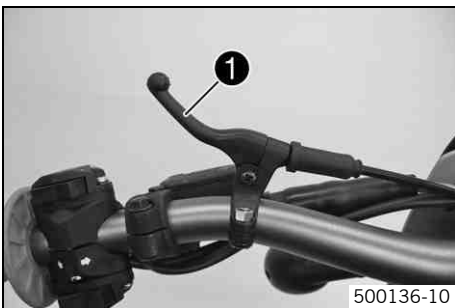

The choke lever ❶ is fitted on the left side of the handlebar.
Activating the choke function frees an opening through which the engine can draw extra fuel. This gives a richer fuel-air mixture, which is needed for a cold start.

i Info

If the engine is warm, the choke function must be deactivated.

Possible states

- Choke function activated – The choke lever is pulled to the stop.
- Choke function deactivated – The choke lever is pushed back to the stop.

Hand brake lever

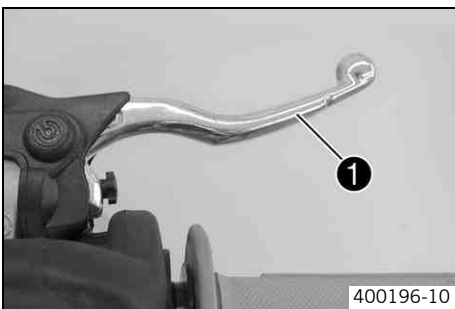

Hand brake lever ❶ is located on the right side of the handlebar.
The hand brake lever is used to activate the front brake.

Throttle grip

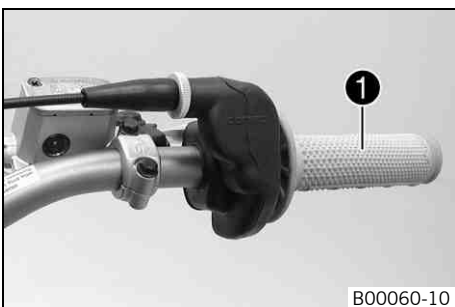

Throttle grip ❶ is fitted on the right side of the handlebar.

Short circuit button (EXC, EXC Factory Edition, EXC SIX DAYS)

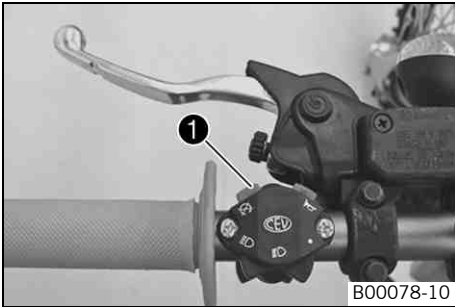

Short circuit button ❶ is fitted on the left side of the handlebar.

Possible states

- Short circuit button ☒ in basic position – In this position, the ignition circuit is closed, and the engine can be started.
- Short circuit button ☒ pressed – In this position, the ignition circuit is interrupted, a running engine stops, and a non-running engine will not start.

Short circuit button (XC-W)

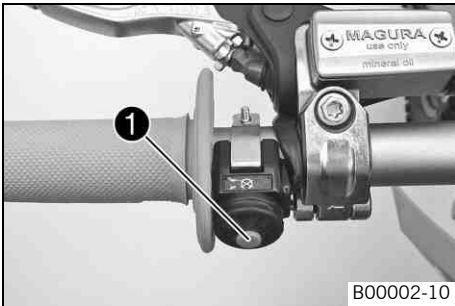

Short circuit button ❶ is fitted on the left side of the handlebar.

Possible states

- Short circuit button ☒ in basic position – In this position, the ignition circuit is closed, and the engine can be started.
- Short circuit button ☒ pressed – In this position, the ignition circuit is interrupted, a running engine stops, and a non-running engine will not start.

Light switch (EXC, EXC Factory Edition, EXC SIX DAYS)

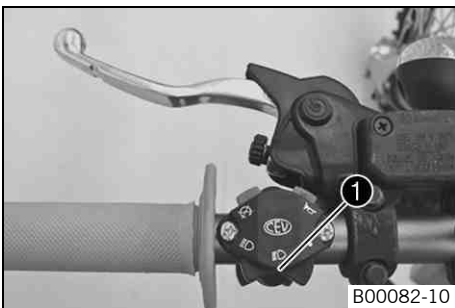

The light switch ❶ is fitted on the left side of the handlebar.

Possible states

●	Light off – Light switch is turned to the right. In this position, the light is switched off.
☞	Low beam on – Light switch is in the central position. In this position, the low beam and tail light are switched on.
☜	High beam on – Light switch is turned to the left. In this position, the high beam and the tail light are switched on.

Turn signal switch (EXC, EXC Factory Edition, EXC SIX DAYS)

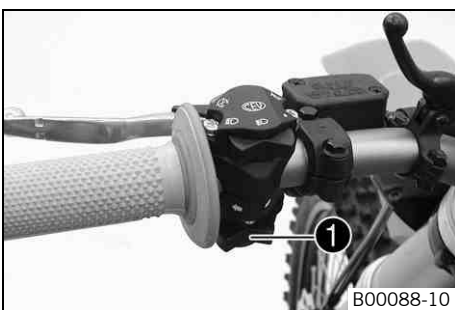

Turn signal switch ❶ is fitted on the left side of the handlebar.

Possible states

●	Turn signal off – The turn signal switch is in the central position.
☜	Left turn signal, on – The turn signal switch is turned to the left.
☞	Right turn signal, on – The turn signal switch is turned to the right.

Horn button (EXC, EXC Factory Edition, EXC SIX DAYS)

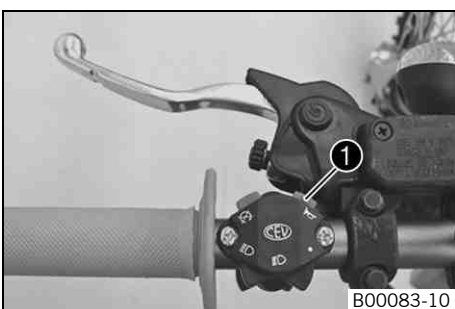

The horn button ❶ is fitted on the left side of the handlebar.

Possible states

- Horn button ☞ in neutral position
- Horn button ☞ pressed – The horn is operated in this position.

Emergency OFF switch (200 EXC AUS)

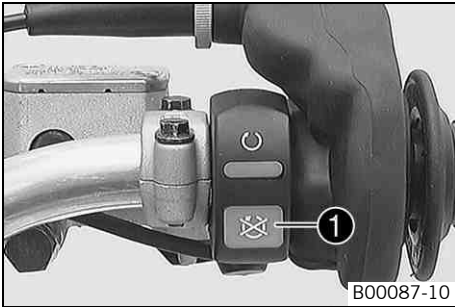

The emergency OFF switch ❶ is fitted on the right side of the handlebar.

Possible states

	Ignition off – In this position, the ignition circuit is interrupted, a running engine stops, and a non-running engine will not start.
	Ignition on – In this position, the ignition circuit is closed, and the engine can be started.

Emergency OFF switch (250/300 EXC AUS)



The emergency OFF switch ❶ is fitted on the right side of the handlebar.

Possible states

	Ignition off – In this position, the ignition circuit is interrupted, a running engine stops, and a non-running engine will not start.
	Ignition on – In this position, the ignition circuit is closed, and the engine can be started.

Electric starter button (All 250/300 EXC EU models, 250/300 XC-W)

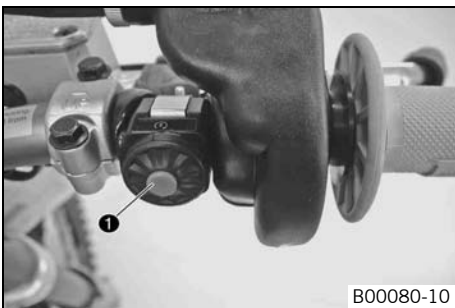

The electric starter button ❶ is fitted on the right side of the handlebar.

Possible states

- Electric starter button ❶ in basic position
- Electric starter button ❶ pressed – In this position, the electric starter is actuated.

Electric starter button (250/300 EXC AUS)



The electric starter button ❶ is fitted on the right side of the handlebar.

Possible states

- Electric starter button ❶ in basic position
- Electric starter button ❶ pressed – In this position, the electric starter is actuated.

Light switch (XC-W)

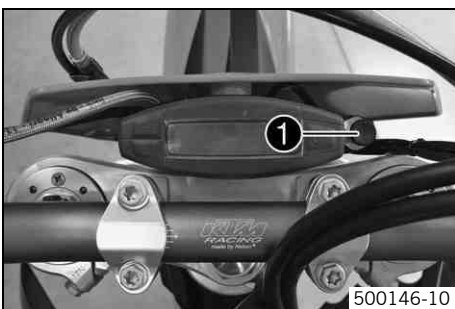

Light switch ❶ is located to the right of the speedometer.

Possible states

- The light switch has no function when the vehicle is delivered – It can be used to retrofit the vehicle with a lighting system.

Overview of indicator lamps (EXC, EXC Factory Edition, EXC SIX DAYS)



Possible states

	High beam indicator lamp lights up blue – High beam is switched on.
	Turn signal indicator lamp flashes green – Turn signal light is switched on.

Speedometer

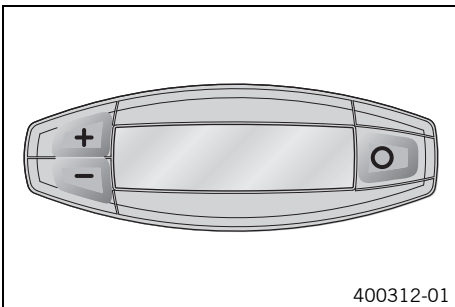

- Press the key to change the display mode or change to one of the Setup menus.
- Press the key to control different functions.
- Press the key to control different functions.

i Info
When the vehicle is delivered, only the **SPEED/H** and **SPEED/ODO** display modes are activated.

Speedometer activation and test

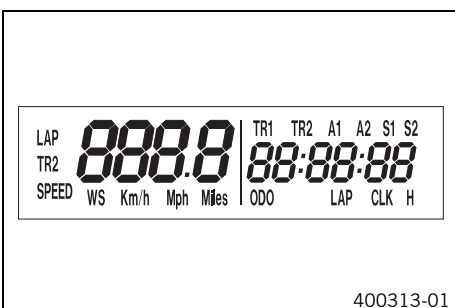

Activating the speedometer

The speedometer is activated when one of the keys is pressed or an impulse comes from the wheel speed sensor.

Display test

For the function test of the display, all display segments light up briefly.

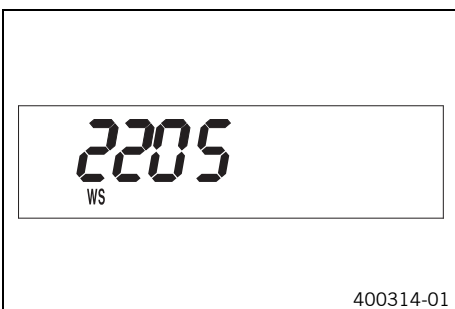

WS (wheel size)

After the display function test, the wheel size **WS** is displayed briefly.

i Info
The number 2205 mm equals the circumference of the 21" front wheel with a series production tire.

The display then changes to the last selected mode.

Tripmaster switch

(Option: Tripmaster switch)

You can use the trip master switch to control the functions of the speedometer from the handlebar.

i Info
The trip master is an optional accessory.

Setting kilometers or miles



Info

If you change the unit of measure, the **ODO** value is retained and converted accordingly. The values **TR1**, **TR2**, **A1**, **A2** and **S1** are cleared when the unit of measure is changed.

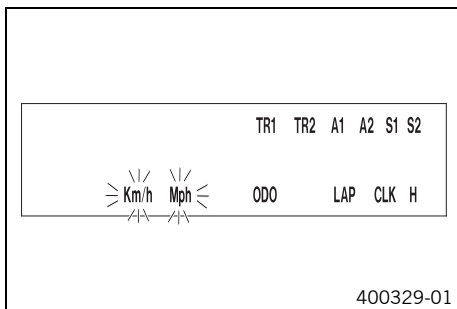

Condition

The motorcycle is stationary.

- Press the button briefly and repeatedly until **H** appears at the bottom right of the display.
- Press the button for 3 - 5 seconds.
 - ✓ The Setup menu is displayed and the active functions are shown.
- Press the button repeatedly until the **Km/h/Mph** display flashes.

Adjusting Km/h

- Press the button .

Adjusting Mph

- Press the button .
- Press the button for 3 - 5 seconds.
 - ✓ The settings are stored and the Setup menu is closed.



Info

If no button is pressed for 20 seconds, or if no impulse comes from the wheel speed sensor, the settings are automatically saved and the Setup menu is closed.

Setting the clock

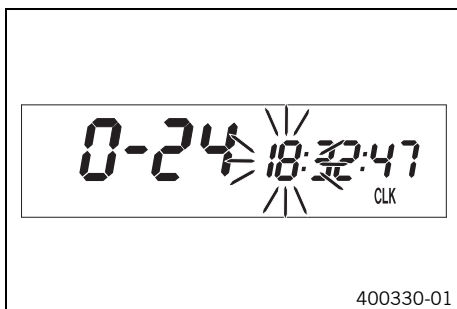

Condition

The motorcycle is stationary.

- Press the button briefly and repeatedly until **CLK** appears at the bottom right of the display.
- Press the button for 3 - 5 seconds.
 - ✓ The hour display flashes.
- Set the hour display with the button and/or button .
- Press the button briefly.
 - ✓ The next segment of the display flashes and can be set.
- You can set the following segments in the same way as the hours by pressing the button and the button .



Info

The seconds can only be set to zero.

- Press the button for 3 - 5 seconds.
 - ✓ The settings are stored and the Setup menu is closed.



Info

If no button is pressed for 20 seconds, or if a pulse arrives from the wheel speed sensor, the settings are stored automatically and the Setup menu is closed.

Adjusting the speedometer functions



Info

When the vehicle is delivered, only the **SPEED/H** and **SPEED/ODO** display modes are activated.

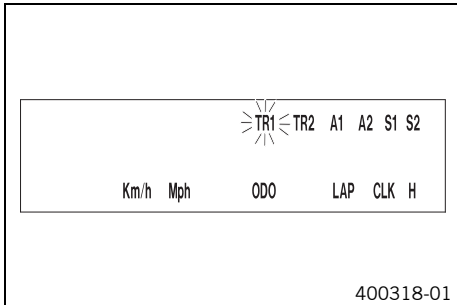

Condition

The motorcycle is stationary.

- Press the button briefly and repeatedly until **H** appears at the bottom right of the display.
- Press the button for 3 - 5 seconds.
 - ✓ The Setup menu is displayed and the activated functions are shown.
- Change to the desired function by pressing the button briefly.
 - ✓ The selected function flashes.

Activating a function

- Press the button .
- ✓ The symbol remains on the screen and the display changes to the next function.

Deactivating the function

- Press the button .
- ✓ The symbol on the screen goes out and the display changes to the next function.
- All desired functions are activated or deactivated accordingly.
- Press the button for 3 - 5 seconds.
 - ✓ The settings are stored and the Setup menu is closed.



Info

If no button is pressed for 20 seconds, or if a pulse arrives from the wheel speed sensor, the settings are stored automatically and the Setup menu is closed.

Querying the lap time



Info

This function can be called only if lap times are measured.

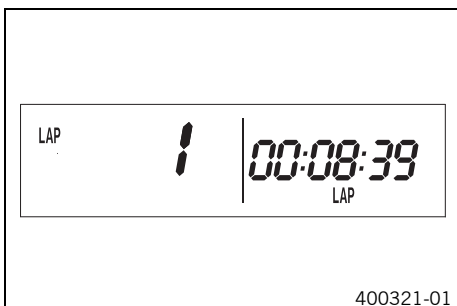

Condition

The motorcycle is stationary.

- Press the button briefly and repeatedly until **LAP** appears at the bottom right of the display.
- Press the button briefly.
 - ✓ **LAP 1** appears on the left side of the display.
- Laps 1-10 can be displayed by pressing the button .
- The button has no function
- Press the button briefly.
 - ✓ Next display mode



Info

If an impulse is received from the wheel speed sensor, the left side of the display changes back to the **SPEED** mode.

Display mode SPEED (speed)



- Press the button  briefly and repeatedly until **SPEED** appears on the left side of the display.

The current speed is displayed in the **SPEED** display mode.
The current speed can be displayed in **Km/h** or **Mph**.

i Info
Making the setting according to the country.
When an impulse comes from the front wheel, the left side of the speedometer display changes to the **SPEED** mode and the current speed is shown.

Display mode SPEED/H (service hours)







Condition

- The motorcycle is stationary.
- Press the button  briefly and repeatedly until **H** appears at the bottom right of the display.

In display mode **H**, the service hours of the engine are displayed.
The service hour counter stores the total traveling time.

i Info
The service hour counter is necessary for ensuring that maintenance work is carried out at the right intervals.
If the speedometer is in **H** display mode at the start of the journey, it automatically changes to the **ODO** display mode.
The **H** display mode is suppressed during the journey.





Press the button  .	No function
Press the button  .	No function
Press the button  for 3 - 5 seconds.	The display changes to the Setup menu of the speedometer functions.
Press the button  briefly.	Next display mode

Display mode SPEED/CLK (clock)



- Press the button  briefly and repeatedly until **CLK** appears at the bottom right of the display.

The time is displayed in **CLK** display mode.



Press the button  .	No function
Press the button  .	No function
Press the button  for 3 - 5 seconds.	The display changes to the Setup menu of the clock.
Press the button  briefly.	Next display mode



Display mode SPEED/LAP (lap time)





- Press the button  briefly and repeatedly until **LAP** appears at the bottom right of the display.

In the **LAP** display mode, up to 10 lap times can be timed with the stop watch.

i Info
If the lap time continues after you press the button , 9 memory locations are already occupied.
Lap 10 must be timed with the button .

Press the button  .	Starts or stops the clock.
Press the button  .	Stops the current lap time and saves it, and the stop watch starts the next lap.



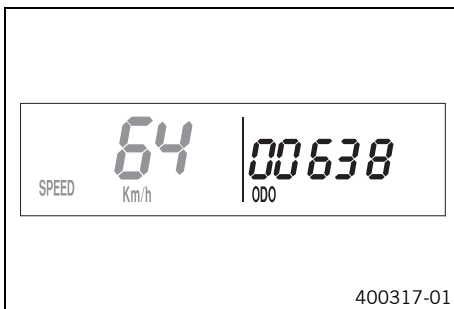

Press the button  for 3 - 5 seconds.	The stop watch and the lap time are reset.
Press the button  briefly.	Next display mode

Display mode SPEED/ODO (odometer)





- Press the button  briefly and repeatedly until **ODO** appears at the bottom right of the display.

The total distance traveled is displayed in the **ODO** display mode.

Press the button  .	No function
Press the button  .	No function
Press the button  for 3 - 5 seconds.	–
Press the button  briefly.	Next display mode

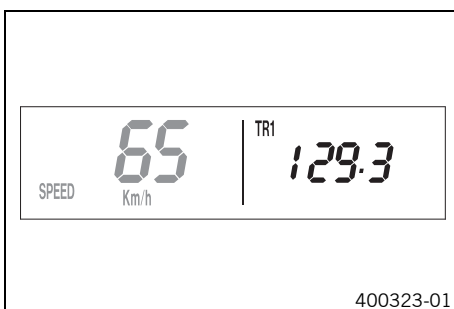
Display mode SPEED/TR1 (trip master 1)







- Press the button  briefly and repeatedly until **TR1** appears at the top right of the display.

TR1 (trip master 1) runs constantly and counts to 999.9.

You can use it to measure trips or the distance between refueling stops.

TR1 is coupled with **A1** (average speed 1) and **S1** (stop watch 1).

i Info
If 999.9 is exceeded, the values of **TR1**, **A1** and **S1** are automatically reset to 0.0.



Press the button  .	No function
Press the button  .	No function
Press the button  for 3 - 5 seconds.	The TR1 , A1 and S1 displays are reset to 0.0.
Press the button  briefly.	Next display mode

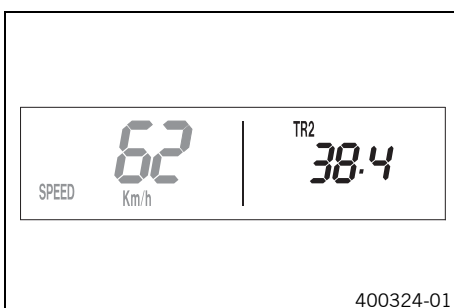

Display mode SPEED/TR2 (trip master 2)







- Press the button  briefly and repeatedly until **TR2** appears at the top right of the display.

TR2 (trip master 2) runs constantly and counts up to 999.9.

The displayed value can be set manually with the button  and the button . This is a very practical function when riding using the road book.

i Info
The **TR2** value can also be corrected manually during the journey with the button  and the button .
If 999.9 is exceeded, the value of **TR2** is automatically reset to 0.0.

Press the button  .	Increases value of TR2 .
Press the button  .	Reduces value of TR2 .
Press the button  for 3 - 5 seconds.	Deletes value of TR2 .
Press the button  briefly.	Next display mode



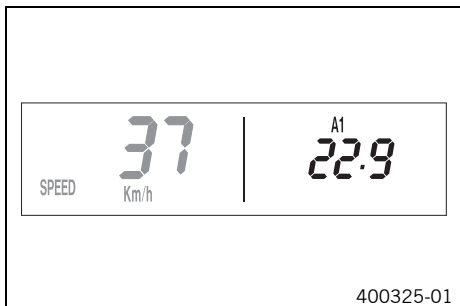

Display mode SPEED/A1 (average speed 1)



- Press the button  briefly and repeatedly until **A1** appears at the top right of the display.

A1 (average speed 1) shows the average speed calculated on the basis of **TR1** (trip master 1) and **S1** (stop watch 1).

The calculation of this value is activated by the first impulse of the wheel speed sensor and ends 3 seconds after the last impulse.

Press the button 	No function
Press the button 	No function
Press the button  for 3 - 5 seconds.	The TR1 , A1 and S1 displays are reset to 0.0.
Press the button  briefly.	Next display mode





Display mode SPEED/A2 (average speed 2)



- Press the button  briefly and repeatedly until **A2** appears at the top right of the display.

A2 (average speed 2) shows the average speed on the basis of the current speed if the stop watch **S2** (stop watch 2) is running.

i Info
The displayed value can differ from the actual average speed if **S2** was not timed after the ride.

Press the button 	No function
Press the button 	No function
Press the button  for 3 - 5 seconds.	–
Press the button  briefly.	Next display mode





Display mode SPEED/S1 (stop watch 1)



- Press the button  briefly and repeatedly until **S1** appears at the top right of the display.

S1 (stop watch 1) displays the journey time on the basis of **TR1** and continues when an impulse is received from the wheel speed sensor.

The calculation of this value starts with the first impulse of the wheel speed sensor and ends 3 seconds after the last impulse.

Press the button 	No function
Press the button 	No function
Press the button  for 3 - 5 seconds.	Displays of TR1 , A1 and S1 are reset to 0.0.
Press the button  briefly.	Next display mode

Display mode SPEED/S2 (stop watch 2)



- Press the button  briefly and repeatedly until **S2** appears at the top right of the display.

S2 (stop watch 2) is a manual stop watch.

If **S2** is running in the background, the **S2** display flashes in the speedometer display.





Press the button 	Starts or stops S2 .
Press the button 	No function
Press the button  for 3 - 5 seconds.	Displays of S2 and A2 are reset to 0.0.
Press the button  briefly.	Next display mode





Table of functions				
Display	Press the button  .	Press the button  .	Press the button  for 3 - 5 seconds.	Press the button  briefly.
Display mode SPEED/H (service hours)	No function	No function	The display changes to the Setup menu of the speedometer functions.	Next display mode
Display mode SPEED/CLK (clock)	No function	No function	The display changes to the Setup menu of the clock.	Next display mode
Display mode SPEED/LAP (lap time)	Starts or stops the clock.	Stops the current lap time and saves it, and the stop watch starts the next lap.	The stop watch and the lap time are reset.	Next display mode
Display mode SPEED/ODO (odometer)	No function	No function	–	Next display mode
Display mode SPEED/TR1 (trip master 1)	No function	No function	The TR1 , A1 and S1 displays are reset to 0.0.	Next display mode
Display mode SPEED/TR2 (trip master 2)	Increases value of TR2 .	Reduces value of TR2 .	Deletes value of TR2 .	Next display mode
Display mode SPEED/A1 (average speed 1)	No function	No function	The TR1 , A1 and S1 displays are reset to 0.0.	Next display mode
Display mode SPEED/A2 (average speed 2)	No function	No function	–	Next display mode
Display mode SPEED/S1 (stop watch 1)	No function	No function	Displays of TR1 , A1 and S1 are reset to 0.0.	Next display mode
Display mode SPEED/S2 (stop watch 2)	Starts or stops S2 .	No function	Displays of S2 and A2 are reset to 0.0.	Next display mode

Table of conditions and menu activation		
Display	The motorcycle is stationary.	Menu can be activated
Display mode SPEED/H (service hours)	•	
Display mode SPEED/CLK (clock)		•
Display mode SPEED/LAP (lap time)		•
Display mode SPEED/TR1 (trip master 1)		•
Display mode SPEED/TR2 (trip master 2)		•
Display mode SPEED/A1 (average speed 1)		•
Display mode SPEED/A2 (average speed 2)		•
Display mode SPEED/S1 (stop watch 1)		•
Display mode SPEED/S2 (stop watch 2)		•

Fuel tap

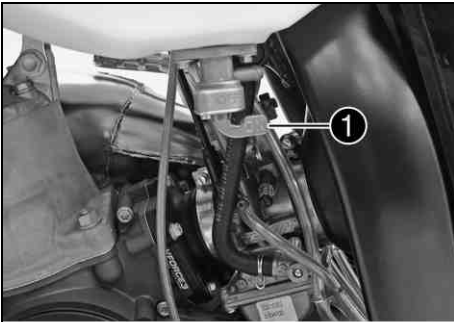

The fuel tap is on the left side of the fuel tank.

Tap handle ❶ on the fuel tap is used to open or close the supply of fuel to the carburetor.

Possible states

- Fuel supply closed **OFF** – No fuel can flow from the tank to the carburetor.
- Fuel supply open **ON** – Fuel can flow from the tank to the carburetor. The fuel tank empties down to the reserve.
- Reserve fuel supply open **RES** – Fuel can flow from the tank to the carburetor. The fuel tank empties completely.

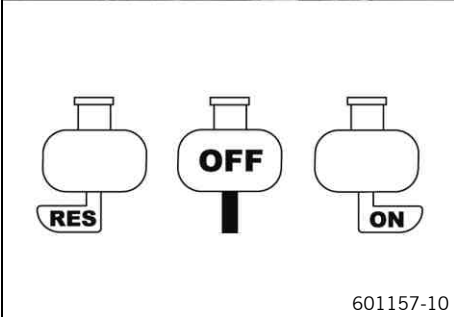

Opening the filler cap



Danger

Fire hazard Fuel is highly flammable.

- Never refuel the vehicle near open flames or burning cigarettes, and always switch off the engine first. Be careful that no fuel is spilt, especially on hot vehicle components. Clean up spilt fuel immediately.
- Fuel in the fuel tank expands when warm and can escape if the tank is overfilled. See the notes on refueling.



Warning

Danger of poisoning Fuel is poisonous and a health hazard.

- Avoid contact between fuel and skin, eyes and clothing. Do not inhale fuel vapors. If fuel gets into your eyes, rinse immediately with water and contact a doctor. Wash affected skin areas immediately with soap and water. If fuel is swallowed, contact a doctor immediately. Change clothing that has come into contact with fuel. Store fuel in a suitable canister according to regulations and keep it out of the reach of children.



Warning

Environmental hazard Improper handling of fuel is a danger to the environment.

- Do not allow fuel to get into the ground water, the ground, or the sewage system.

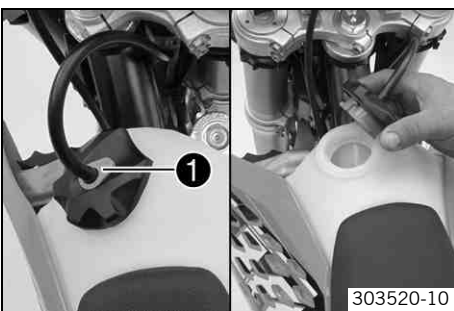

- Press release button ❶, turn the filler cap counterclockwise and lift it free.

Closing the filler cap

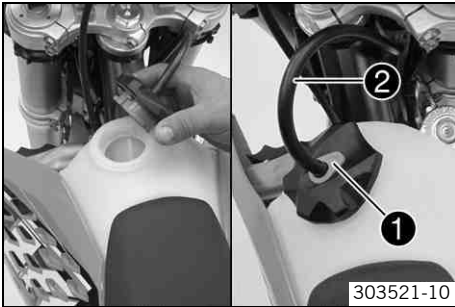

303521-10

- Replace the filler cap and turn clockwise until the release button ❶ locks in place.



Info

Run the fuel tank breather hose ❷ without kinks.

Choke (EXC AUS, XC-W)

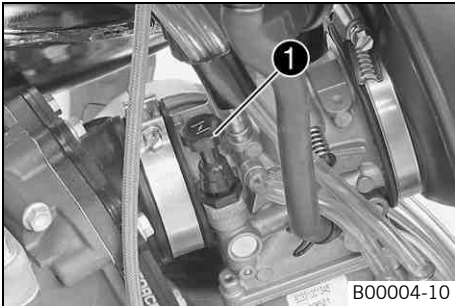

B00004-10

The choke lever ❶ is fitted on the left side of the carburetor. Activating the choke function frees an opening through which the engine can draw extra fuel. This gives a richer fuel-air mixture, which is needed for a cold start.



Info

If the engine is warm, the choke function must be deactivated.

Possible states

- Choke function activated – The choke lever is pulled out all the way.
- Choke function deactivated – The choke lever is pushed in all the way.

Shift lever

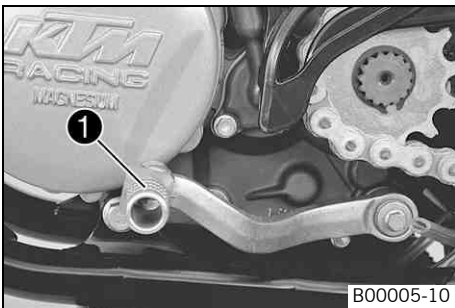

B00005-10

Shift lever ❶ is mounted on the left side of the engine.

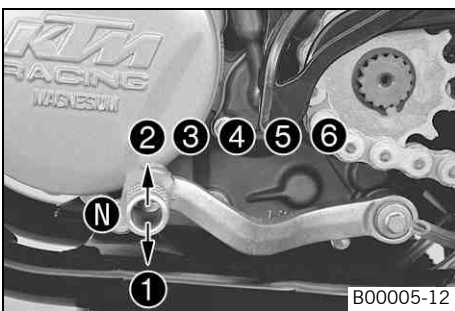

B00005-12

The gear positions can be seen in the photograph. The neutral or idle position is between the first and second gears.

Kickstarter

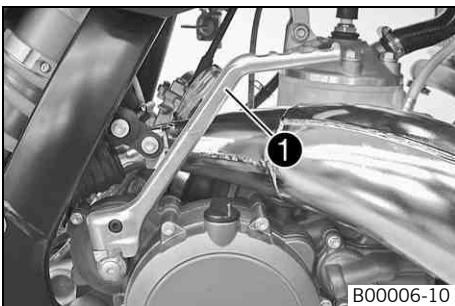

B00006-10

The kickstarter ❶ is fitted on the right side of the engine. The top part can be swiveled.

Foot brake lever

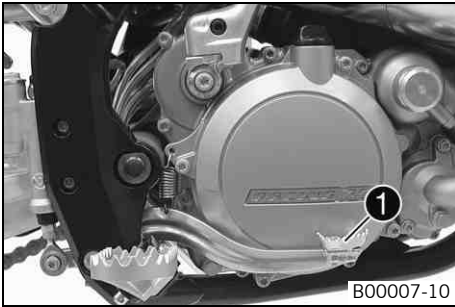

Foot brake lever ❶ is located in front of the right footrest. The foot brake lever is used to activate the rear brake.

Side stand

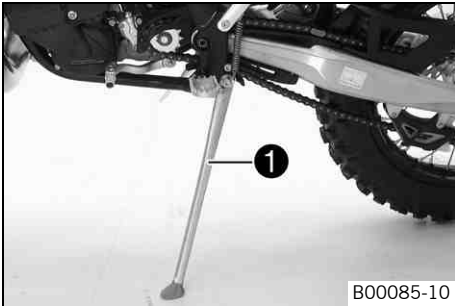

The side stand ❶ is on the left side of the vehicle.

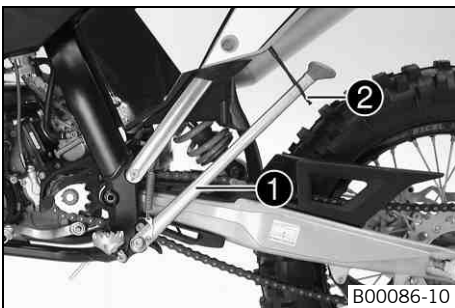

The side stand is used to park the motorcycle.

i Info
When you are riding, side stand ❶ must be folded up and secured with rubber band ❷.

Steering lock (EXC, EXC Factory Edition, EXC SIX DAYS)

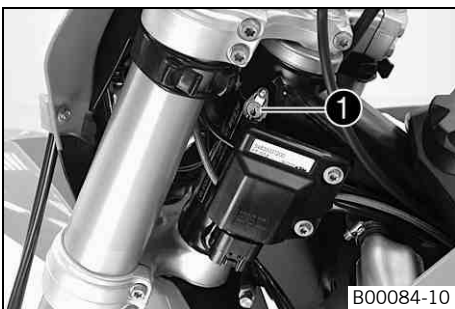

Steering lock ❶ is fitted on the left side of the steering head. The steering lock is used to lock the steering. Steering, and therefore riding, is no longer possible.

Locking the steering (EXC, EXC Factory Edition, EXC SIX DAYS)

Note

Danger of damage The parked vehicle may roll away or fall over.

- Always place the vehicle on a firm and even surface.

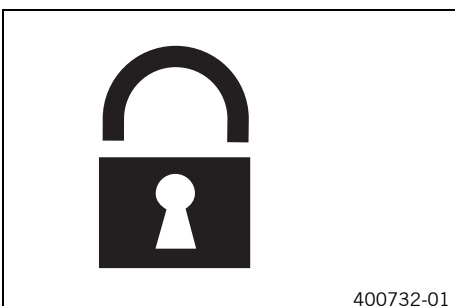

- Park the vehicle.
- Turn the handlebar as far as possible to the right.
- Insert the key in the steering lock, turn it to the left, press it in and turn it to the right. Remove the key.
- ✓ Steering is no longer possible.

i Info
Never leave the key in the steering lock.

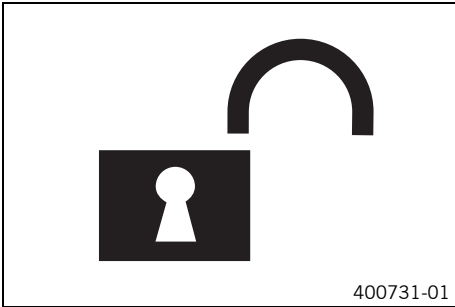
Unlocking the steering (EXC, EXC Factory Edition, EXC SIX DAYS)

- Insert the key in the steering lock, turn it to the left, pull it out and turn it to the right. Remove the key.

✓ You can now steer the bike again.

**Info**

Never leave the key in the steering lock.

Advice on first use



Danger

Danger of accidents Danger arising from the rider's judgement being impaired.

- Do not operate the vehicle while under the influence of alcohol, drugs and certain medications or physically or mentally impaired.



Warning

Risk of injury Missing or poor protective clothing present an increased safety risk.

- Wear protective clothing (helmet, boots, gloves, pants and jacket with protectors) every time you ride the vehicle. Always wear protective clothing, which must be undamaged and meet legal requirements.



Warning

Danger of crashing Poor vehicle handling due to different tire tread patterns on front and rear wheels.

- The front and rear wheels must be fitted with tires with similar tread patterns to prevent loss of control over the vehicle.



Warning

Danger of accidents Critical riding behavior due to inappropriate riding.

- Adapt your riding speed to the road conditions and your riding ability.



Warning

Danger of accidents Accident risk caused by presence of a passenger.

- Your vehicle is not designed to carry passengers. Do not ride with a passenger.



Warning

Danger of accidents Failure of brake system.

- If the foot brake lever is not released, the brake linings drag continuously. The rear brake may fail due to overheating. Take your foot off the foot brake lever when you are not braking.



Warning

Danger of accidents Unstable riding behavior.

- Do not exceed the maximum permissible weight and axle loads.



Warning

Risk of misappropriation Usage by unauthorized persons.

- Never leave the vehicle while the engine is running. Secure the vehicle against use by unauthorized persons.



Info

When using your motorcycle, remember that others may feel disturbed by excessive noise.

- Make sure that the pre-delivery inspection work has been carried out by an authorized KTM workshop.
 - ✓ You receive a delivery certificate and the service record at vehicle handover.
- Before your first trip, read the entire operating instructions carefully.
- Get to know the controls.
- Adjust the basic position of the clutch lever. (☞ p. 66)

(XC-W)

- Adjust the basic position of the hand brake lever. (☞ p. 69)

(EXC, EXC Factory Edition, EXC SIX DAYS)

- Adjust the free travel of the hand brake lever. (☞ p. 69)
- Adjust the basic position of the foot brake lever. ☞ (☞ p. 73)
- Adjust the basic position of the shift lever. ☞ (☞ p. 94)
- Get used to handling the motorcycle on a suitable piece of land before making a longer trip.



Info

Offroad, you should be accompanied by another person on another machine so that you can help each other.

- Try also to ride as slowly as possible and in a standing position to get a better feeling for the vehicle.
- Do not make any offroad trips that over-stress your ability and experience.

- Hold the handlebar firmly with both hands and keep your feet on the footrests when riding.
- If you carry any baggage, make sure it is fixed firmly as close as possible to the center of the vehicle and ensure even weight distribution between the front and rear wheels.

i Info

Motorcycles react sensitively to any changes of weight distribution.

- Do not exceed the overall maximum permitted weight and the axle loads.

Guideline

Maximum permissible overall weight	335 kg (739 lb.)
Maximum permissible front axle load	145 kg (320 lb.)
Maximum permissible rear axle load	190 kg (419 lb.)

- Check the spoke tension. (☛ p. 81)

i Info

The spoke tension must be checked after riding the motorcycle for one half hour.

- Run the engine in.

Running in the engine

- During the running-in phase, do not exceed the specified engine performance.

Guideline

Maximum engine performance	
During the first 3 service hours	< 70 %
During the first 5 service hours	< 100 %

- Avoid fully opening the throttle!

Preparing the vehicle for difficult operating conditions

- The use of motorcycles under difficult operating conditions can lead to above-average wear of components such as the drive train or brakes. For this reason, it may be necessary to service or replace worn parts before the limit specified in the service schedule is reached.

Difficult operating conditions are:

- Riding on dry sand. (☛ p. 27)
- Riding on wet sand. (☛ p. 28)
- Riding on wet and muddy surfaces. (☛ p. 29)
- Riding at high temperatures and low speeds. (☛ p. 30)
- Riding at low temperatures and in snow. (☛ p. 30)

Preparations for riding on dry sand



600872-10

- Check the radiator cap.

Value on the radiator cap	1.8 bar (26 psi)
---------------------------	------------------

» If the displayed value does not equal the setpoint value:



Warning

Danger of scalding During motorcycle operation, the coolant gets very hot and is under pressure.

- Do not remove the radiator cap, radiator hoses or other cooling system components when the engine is hot. Allow the engine and cooling system to cool down. In case of scalding, rinse immediately with lukewarm water.

- Change the radiator cap.

- Seal the air filter box. ☛



Tip

Seal the air filter box at the edges to prevent dirt from entering.



- Clean the air filter and air filter box. 🛠️ (📖 p. 58)

i Info
Check the air filter approx. every 30 minutes.

- Mount the dust cover for the air filter.

Dust cover for air filter (59006019000)

i Info
Read the **KTM PowerParts** installation instructions.

- Mount the dust cover for the air filter for sand.

Sand cover for air filter (59006022000)

i Info
Read the **KTM PowerParts** installation instructions.

- Adjust the carburetor jetting and setting.

i Info
Recommendations on the carburetor setting are available from your authorized KTM workshop.

- Clean the chain.

Chain cleaner (🛠️ p. 127)

- Mount the steel sprocket.

i Tip
Do not grease the chain.

- Clean the radiator fins.
- Carefully align bent radiator fins.
- If used in sand regularly, replace the piston every 10 operating hours.

Preparations for riding on wet sand



- Check the radiator cap.

Value on the radiator cap	1.8 bar (26 psi)
---------------------------	------------------

» If the displayed value does not equal the setpoint value:

⚠ Warning
Danger of scalding During motorcycle operation, the coolant gets very hot and is under pressure.

- Do not remove the radiator cap, radiator hoses or other cooling system components when the engine is hot. Allow the engine and cooling system to cool down. In case of scalding, rinse immediately with lukewarm water.

- Change the radiator cap.

- Seal the air filter box. 🛠️

i Tip
Seal the air filter box at the edges to prevent dirt from entering.

- Clean the air filter and air filter box. 🛠️ (📖 p. 58)

i Info
Check the air filter approx. every 30 minutes.



- Mount the rain cover for the air filter.

Rain cover for air filter (59006021000)

i Info
Read the **KTM PowerParts** installation instructions.

- Adjust the carburetor jetting and setting.

i Info
Recommendations on the carburetor setting are available from your authorized KTM workshop.



- Clean the chain.

Chain cleaner (☞ p. 127)

- Mount the steel sprocket.

i Tip
Do not grease the chain.

- Clean the radiator fins.
- Carefully align bent radiator fins.
- If used in sand regularly, replace the piston every 10 operating hours.

Preparations for riding on wet and muddy surfaces

- Seal the air filter box. ☞

i Tip
Seal the air filter box at the edges to prevent dirt from entering.

- Clean the air filter and air filter box. ☞ (☞ p. 58)

i Info
Check the air filter approx. every 30 minutes.

- Mount the rain cover for the air filter.

Rain cover for air filter (59006021000)

i Info
Follow the **KTM PowerParts** mounting instructions.

- Adjust the carburetor jetting and setting.

i Info
The recommended carburetor tuning is available from your authorized KTM workshop.



- Mount the steel sprocket.
- Clean the motorcycle. (☞ p. 100)
- Carefully align bent radiator fins.

Preparations for riding at high temperatures and low speeds



600872-10

- Check the radiator cap.

Value on the radiator cap	1.8 bar (26 psi)
---------------------------	------------------

- » If the displayed value does not equal the setpoint value:



Warning

Danger of scalding During motorcycle operation, the coolant gets very hot and is under pressure.

- Do not remove the radiator cap, radiator hoses or other cooling system components when the engine is hot. Allow the engine and cooling system to cool down. In case of scalding, rinse immediately with lukewarm water.

- Change the radiator cap.

- Seal the air filter box. 🐾



Tip

Seal the air filter box at the edges to prevent dirt from entering.

- Clean the air filter and air filter box. 🐾 (👉 p. 58)



Info

Check the air filter approx. every 30 minutes.

- Adjust the secondary ratio to the terrain.



Info

The engine oil heats up rapidly if the clutch needs to be operated too frequently because the secondary ratio is too long.

- Clean the chain.

Chain cleaner (👉 p. 127)

- Clean the radiator fins.
- Carefully align bent radiator fins.
- Check the coolant level. (👉 p. 89)



600868-01

Preparations for riding at low temperatures and in snow

- Seal the air filter box. 🐾



Tip

Seal the air filter box at the edges to prevent dirt from entering.

- Clean the air filter and air filter box. 🐾 (👉 p. 58)



Info

Check the air filter approx. every 30 minutes.

- Mount the rain cover for the air filter.

Rain cover for air filter (59006021000)



Info

Follow the **KTM PowerParts** mounting instructions.

- Adjust the carburetor jetting and setting.



Info

The recommended carburetor tuning is available from your authorized KTM workshop.



600870-01

Checks and maintenance work when preparing for use



Info

Before riding the vehicle, always check its condition and operating safety. The vehicle must be in perfect technical condition when used.

- Check the gear oil level. (☞ p. 97)
- Check the front brake fluid level. (☞ p. 70)
- Check the rear brake fluid level. (☞ p. 74)
- Check the front brake linings. (☞ p. 71)
- Check the rear brake linings. (☞ p. 75)
- Check that the brake system is functioning properly.
- Check the coolant level. (☞ p. 89)
- Check the chain for dirt. (☞ p. 61)
- Check the chain, rear sprocket, engine sprocket, and chain guide. (☞ p. 62)
- Check the chain tension. (☞ p. 62)
- Check the tire condition. (☞ p. 80)
- Check the tire air pressure. (☞ p. 81)
- Clean the dust boots of the fork legs. (☞ p. 46)
- Bleed the fork legs. (☞ p. 45)
- Check the air filter.
- Check the settings of all controls and ensure that they can be operated smoothly.
- Check all screws, nuts and hose clamps regularly for tightness.
- Check the fuel supply.

Starting



Danger

Danger of poisoning Exhaust gases are poisonous and inhaling them may result in unconsciousness and/or death.

- When running the engine, always make sure there is sufficient ventilation, and do not start or run the engine in an enclosed space without an effective exhaust extraction system.

Note

Engine failure High engine speeds in cold engines have a negative effect on the service life of the engine.

- Always warm up the engine at low engine speeds.



Info

If the motorcycle is unwilling to start, the cause can be old fuel in the float chamber. The flammable elements of the fuel evaporate after a long time of standing.

If the float chamber is filled with fresh fuel, the engine starts immediately.

Engine has been out of use for more than one week

- Empty the carburetor float chamber. ☞ (☞ p. 94)
- Turn handle ❶ of the fuel tap to the **ON** position. (Figure 601157-10☞ p. 22)
 - ✓ Fuel can flow from the fuel tank to the carburetor.
- Remove the motorcycle from the stand.
- Shift gear to neutral.

(200 EXC AUS)

- Turn the emergency OFF switch to the position ○.

(250/300 EXC AUS)

- Turn the emergency OFF switch to the position ○.

The engine is cold

(EXC EU, EXC SIX DAYS, EXC Factory Edition)

- Pull the choke lever to the stop.

(EXC AUS, XC-W)

- Pull out the choke lever all the way.
- Press the electric starter button or press the kickstarter robustly through its full range.

**Info**

Do not open the throttle.

Starting up**Info**

Before riding, switch on the lights if your vehicle is equipped with a lighting system. This will make it easier for other road users to see you.

When you are riding, the side stand must be folded up and secured with the rubber band.

- Pull the clutch lever, engage 1st gear, release the clutch lever slowly and simultaneously open the throttle carefully.

Shifting, riding**Warning**

Danger of accidents If you change down at high engine speed, the rear wheel can lock up.

- Do not change into a low gear at high engine speed. The engine races and the rear wheel can lock up.

**Info**

If you hear unusual noises while riding, stop immediately, switch off the engine and contact an authorized KTM workshop. First gear is used for starting off or for steep inclines.

- When conditions allow (incline, road situation, etc.), you can shift into a higher gear. To do so, release the throttle while simultaneously pulling the clutch lever, shift into the next gear, release the clutch and open the throttle.
- If the choke function was activated, deactivate it after the engine has warmed up.
- When you reach maximum speed after fully opening the throttle, turn back the throttle to about $\frac{3}{4}$ of its range. This barely reduces vehicle speed but lowers fuel consumption considerably.
- Always open the throttle only as much as the engine can handle – abrupt throttle opening increases fuel consumption.
- To shift down, brake and close the throttle at the same time.
- Pull the clutch lever and shift into a lower gear, release the clutch lever slowly and open the throttle or shift again.
- Switch off the engine if you expect to be standing for a long time.

Guideline

≥ 2 min

- Avoid frequent and longer slipping of the clutch. This heats the engine oil, the engine and the cooling system.
- Ride with a lower engine speed instead of with a high engine speed and a slipping clutch.

Braking**Warning**

Danger of accidents If you brake too hard, the wheels can lock.

- Adapt your braking to the traffic situation and the road conditions.

**Warning**

Danger of accidents Reduced braking efficiency caused by spongy pressure point of front or rear brake.

- Check the brake system and do not continue riding. (Your authorized KTM workshop will be glad to help.)

**Warning**

Danger of accidents Reduced braking efficiency due to wet or dirty brakes.

- Clean or dry dirty or wet brakes by riding and braking gently.

- On sandy, wet or slippery surfaces, use the rear brake.
- Braking should always be completed before you go into a bend. Change down to a lower gear appropriate to your road speed.

Stopping, parking



Warning

Risk of misappropriation Usage by unauthorized persons.

- Never leave the vehicle while the engine is running. Secure the vehicle against use by unauthorized persons.



Warning

Danger of burns Some vehicle components become very hot when the vehicle is operated.

- Do not touch hot components such as exhaust system, radiator, engine, shock absorber and brakes. Allow these components to cool down before starting work on them.

Note

Danger of damage The parked vehicle may roll away or fall over.

- Always place the vehicle on a firm and even surface.

Note

Fire hazard Some vehicle components become very hot when the vehicle is operated.

- Do not park the vehicle near flammable or explosive substances. Do not place objects on the vehicle while it is still warm from being run. Always let the vehicle cool first.

Note

Material damage Damage and destruction of components by excessive load.

- The side stand is designed for the weight of the motorcycle only. Do not sit on the motorcycle when it is supported by the side stand only. The side stand and/or the frame could be damaged and the motorcycle could fall over.

- Brake the motorcycle.

- Shift gear to neutral.

(EXC, EXC Factory Edition, EXC SIX DAYS)

- Press and hold the short circuit button  while the engine is idling until the engine stops.

(XC-W)

- Press and hold the short circuit button  while the engine is idling until the engine stops.

- Turn handle  of the fuel tap to the **OFF** position.

- Park the motorcycle on firm ground.

Refueling



Danger

Fire hazard Fuel is highly flammable.

- Never refuel the vehicle near open flames or burning cigarettes, and always switch off the engine first. Be careful that no fuel is spilt, especially on hot vehicle components. Clean up spilt fuel immediately.
- Fuel in the fuel tank expands when warm and can escape if the tank is overfilled. See the notes on refueling.



Warning

Danger of poisoning Fuel is poisonous and a health hazard.

- Avoid contact of the fuel with skin, eyes and clothing. Do not inhale fuel vapors. If fuel gets into your eyes, rinse immediately with water and contact a doctor. Wash affected skin areas immediately with soap and water. If fuel is swallowed, contact a doctor immediately. Change clothing that has come into contact with fuel.



Warning

Environmental hazard Improper handling of fuel is a danger to the environment.

- Do not allow fuel to get into the ground water, the ground, or the sewage system.

- Switch off the engine.

- Open the filler cap. ( p. 22)

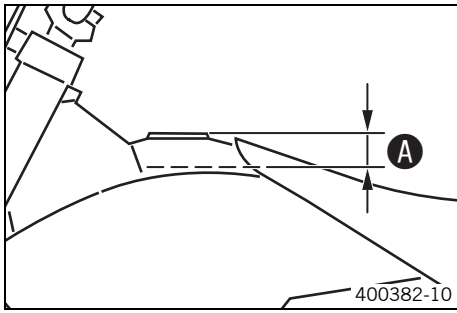

- Fill the fuel tank with fuel up to measurement **A**.

Guideline

Measurement of A	35 mm (1.38 in)	
Total fuel tank capacity, approx. (EXC EU, EXC SIX DAYS, EXC Factory Edition)	9.5 l (2.51 US gal)	Super unleaded gasoline, mixed with 2-stroke engine oil (1:60) (☛ p. 126)
Total fuel tank capacity, approx. (EXC AUS, XC-W)	11.5 l (3.04 US gal)	Super unleaded gasoline, mixed with 2-stroke engine oil (1:60) (☛ p. 126)
2-stroke engine oil (☛ p. 125)		

- Close the filler cap. (☛ p. 23)

Service schedule

	S20A	S40A
Check that the electrical equipment is functioning properly.	•	•
Check and charge the battery. 🛠️ (All 250/300 models)	•	•
Change the gear oil. 🛠️ (📖 p. 97)	•	•
Check the front brake linings. (📖 p. 71)	•	•
Check the rear brake linings. (📖 p. 75)	•	•
Check the brake discs. (📖 p. 70)	•	•
Check the brake lines for damage and leakage.	•	•
Check the rear brake fluid level. (📖 p. 74)	•	•
Check the free travel of the foot brake lever. (📖 p. 73)	•	•
Check the frame and swingarm. 🛠️	•	•
Check the swingarm bearing. 🛠️		•
Check the heim joints at the top and bottom of the shock absorber. 🛠️	•	•
Check the tire condition. (📖 p. 80)	•	•
Check the tire air pressure. (📖 p. 81)	•	•
Check the wheel bearing for play. 🛠️	•	•
Check the wheel hub. 🛠️	•	•
Check the rim run-out. 🛠️	•	•
Check the spoke tension. (📖 p. 81)	•	•
Check the chain, rear sprocket, engine sprocket, and chain guide. (📖 p. 62)	•	•
Check the chain tension. (📖 p. 62)	•	•
Grease all moving parts (e.g. side stand, hand lever, chain, ...) and check for smooth operation. 🛠️	•	•
Check the fluid level of the hydraulic clutch. (📖 p. 66)	•	•
Check the front brake fluid level. (📖 p. 70)	•	•
Check the free travel of the hand brake lever. (📖 p. 69)	•	•
Check the play of the steering head bearing. (📖 p. 53)	•	•
Change the spark plug and spark plug connector. 🛠️	•	•
Check the intake diaphragm. 🛠️	•	•
Check the exhaust control for functioning and smooth operation. 🛠️		•
Check the clutch. 🛠️		•
Check all hoses (e. g. fuel, cooling, bleeding, drainage) and sleeves for tearing, tightness and correct routing. 🛠️	•	•
Check the antifreeze and coolant level. (📖 p. 88)	•	•
Check the cables for damage and routing without sharp bends. 🛠️	•	•
Check that the throttle cables are undamaged, routed without sharp bends and set correctly.	•	•
Clean the air filter and air filter box. 🛠️ (📖 p. 58)	•	•
Change the glass fiber yarn filling of the main silencer. 🛠️ (📖 p. 59)	•	•
Check the screws and nuts for tightness. 🛠️	•	•
Check the headlight setting. (EXC, EXC Factory Edition, EXC SIX DAYS) (📖 p. 86)	•	•
Check the idle.	•	•
Final check: Check the vehicle for safe operation and take a test ride.	•	•
Make the service entry in KTM DEALER.NET and in the service record. 🛠️	•	•

S20A: Every 20 operating hours

S40A: Every 40 operating hours/after every race

Maintenance work (as an additional order)

	S10N	S40A	S80A	J1A
Change the front brake fluid. 🛠️				•
Change the rear brake fluid. 🛠️				•
Change the foot brake cylinder seals. 🛠️				•
Change the hydraulic clutch fluid. 🛠️ (🔧 p. 67)				•
Grease the steering head bearing. 🛠️ (🔧 p. 54)				•
Check/set the carburetor components. 🛠️			•	•
Perform a fork service. 🛠️	•	•	•	
Service the shock absorber. 🛠️		•	•	
Check the starter drive. 🛠️ (All 250/300 models)		•	•	
Change the piston and check the cylinder. 🛠️ (All 125 models)		•	•	
Change the piston and check the cylinder. 🛠️ (All 200/250/300 models)			•	
Change the connecting rod, conrod bearing and crank pin. 🛠️			•	
Check the transmission and shift mechanism. 🛠️			•	
Change all engine bearings. 🛠️			•	

S10N: Once after 10 operating hours

S40A: Every 40 operating hours

S80A: Every 80 operating hours/every 40 operating hours after sporting use

J1A: Annually

Checking the basic chassis setting with the rider's weight

i Info

When adjusting the basic chassis setting, first adjust the shock absorber and then the fork.

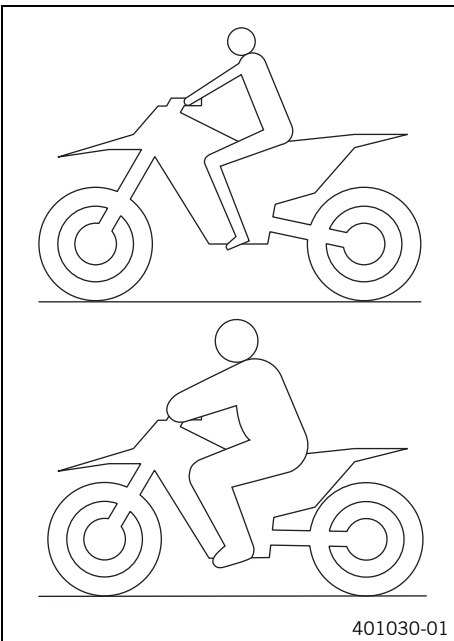

- For optimal motorcycle riding characteristics and to avoid damage to forks, shock absorbers, swingarm and frame, the basic settings of the suspension components must match the rider's weight.
- As delivered, KTM offroad motorcycles are adjusted for a standard rider weight (with full protective clothing).

Guideline

Standard rider weight	75... 85 kg (165... 187 lb.)
-----------------------	------------------------------

- If the rider's weight is above or below the standard range, the basic setting of the suspension components must be adjusted accordingly.
- Small weight differences can be compensated by adjusting the spring preload, but in the case of large weight differences, the springs must be replaced.

Compression damping of shock absorber

The compression damping of the shock absorber is divided into two ranges: high-speed and low-speed.

High-speed and low-speed refer to the compression speed of the rear wheel suspension and not to the vehicle speed.

The high-speed setting, for example, affects the compression when landing after a jump: the rear wheel suspension compresses more quickly.

The low-speed setting, for example, affects the compression when riding over long ground swells: the rear wheel suspension compresses more slowly.

These two ranges can be adjusted separately, although the transition between high-speed and low-speed is gradual. Thus, changes in the high-speed range affect the compression damping in the low-speed range and vice versa.

Adjusting the high-speed compression damping of the shock absorber

⚠ Caution

Danger of accidents Disassembly of pressurized parts can lead to injury.

- The shock absorber is filled with high density nitrogen. Adhere to the description provided. (Your authorized KTM workshop will be glad to help.)

i Info

The high-speed setting can be seen during the fast compression of the shock absorber.

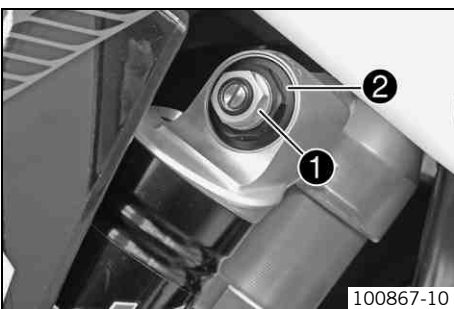

- Turn adjusting screw ❶ all the way clockwise using a socket wrench.

i Info

Do not loosen nut ❷!

- Turn back counterclockwise by the number of turns corresponding to the shock absorber type.

Guideline

(All 125/200 models)

Compression damping, high-speed	
Comfort	2 turns
Standard	1.5 turns
Sport	1.25 turns

(All 250/300 models)

Compression damping, high-speed	
Comfort	2 turns
Standard	1.5 turns
Sport	1.25 turns

i Info
Turn clockwise to increase damping; turn counterclockwise to reduce damping.

Adjusting the low-speed compression damping of the shock absorber

⚠ Caution
Danger of accidents Disassembly of pressurized parts can lead to injury.

- The shock absorber is filled with high density nitrogen. Adhere to the description provided. (Your authorized KTM workshop will be glad to help.)

i Info
The low-speed setting can be seen during the slow to normal compression of the shock absorber.

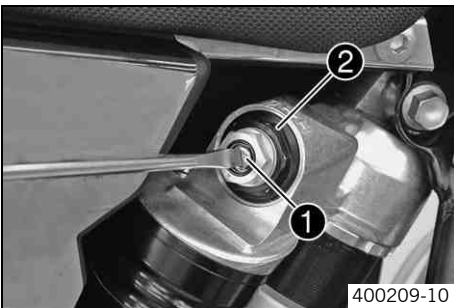

- Turn adjusting screw ❶ clockwise with a screwdriver to the last click.

i Info
Do not loosen nut ❷!

- Turn back counterclockwise by the number of clicks corresponding to the shock absorber type.

Guideline
(All 125/200 models)

Compression damping, low-speed	
Comfort	22 clicks
Standard	20 clicks
Sport	15 clicks

(All 250/300 models)

Compression damping, low-speed	
Comfort	22 clicks
Standard	20 clicks
Sport	15 clicks

i Info
Turn clockwise to increase damping; turn counterclockwise to reduce damping.

Adjusting the rebound damping of the shock absorber

⚠ Caution
Danger of accidents Disassembly of pressurized parts can lead to injury.

- The shock absorber is filled with high density nitrogen. Adhere to the description provided. (Your authorized KTM workshop will be glad to help.)

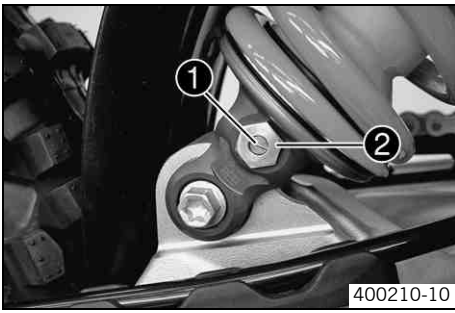

- Turn adjusting screw ❶ clockwise with a screwdriver to the last click.

i Info
Do not loosen nut ❷!

- Turn back counterclockwise by the number of clicks corresponding to the shock absorber type.

Guideline
(All 125/200 models)

Rebound damping	
Comfort	26 clicks
Standard	24 clicks
Sport	22 clicks

(All 250/300 models)

Rebound damping	
Comfort	26 clicks
Standard	24 clicks
Sport	22 clicks

i Info
Turn clockwise to increase damping; turn counterclockwise to reduce damping.

Measuring the sag of the unloaded rear wheel

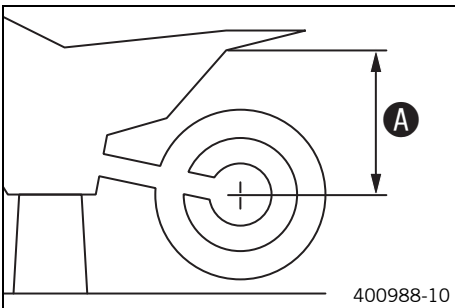

- Raise the motorcycle with the lift stand. (☛ p. 45)
- Measure the distance – as vertical as possible – between the rear axle and a fixed point, for example, a mark on the side cover.
- Note down the value as dimension A.
- Remove the motorcycle from the lift stand. (☛ p. 45)

Checking the static sag of the shock absorber

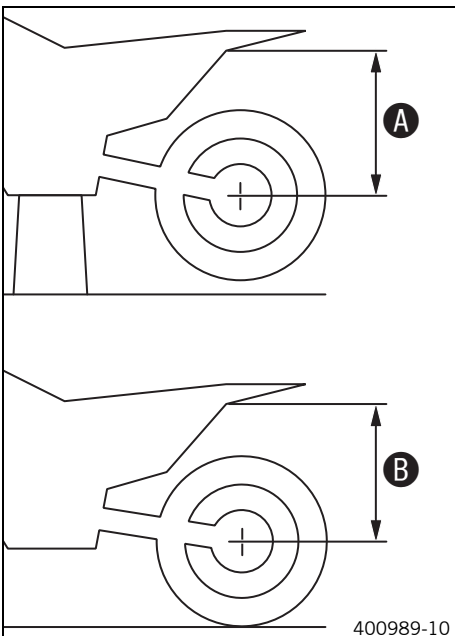

- Measure distance A of the unloaded rear wheel. (☛ p. 39)
- Hold the motorcycle upright with the aid of an assistant.
- Measure the distance between the rear axle and the fixed point again.
- Note down the value as dimension B.

i Info
The static sag is the difference between measurements A and B.

- Check the static sag.

(All 125/200 models)

Static sag	35 mm (1.38 in)
------------	-----------------

(All 250/300 models)

Static sag	35 mm (1.38 in)
------------	-----------------

- » If the static sag is less or more than the specified value:
 - Adjust the spring preload of the shock absorber. ☛ (☛ p. 40)

Checking the riding sag of the shock absorber

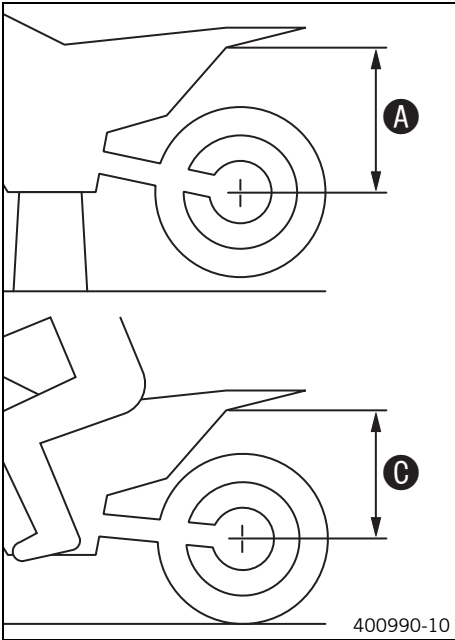

- Measure distance **A** of the unloaded rear wheel. (🔧 p. 39)
- With another person holding the motorcycle, the rider, wearing full protective clothing, sits on the seat in a normal sitting position (feet on footrests) and bounces up and down a few times.
 - ✓ The rear wheel suspension levels out.
- Another person now measures the distance between the rear axle and a fixed point.
- Note down the value as dimension **C**.

i Info

The riding sag is the difference between measurements **A** and **C**.

- Check the riding sag.

Guideline

(All 125/200 models)

Riding sag	105 mm (4.13 in)
------------	------------------

(All 250/300 models)

Riding sag	105 mm (4.13 in)
------------	------------------

- » If the riding sag differs from the specified measurement:
 - Adjust the riding sag. 🛠️ (🔧 p. 41)

Adjusting the spring preload of the shock absorber 🛠️

⚠️ Caution

Danger of accidents Disassembly of pressurized parts can lead to injury.

- The shock absorber is filled with high density nitrogen. Adhere to the description provided. (Your authorized KTM workshop will be glad to help.)

i Info

Before changing the spring preload, make a note of the present setting, e.g., by measuring the length of the spring.

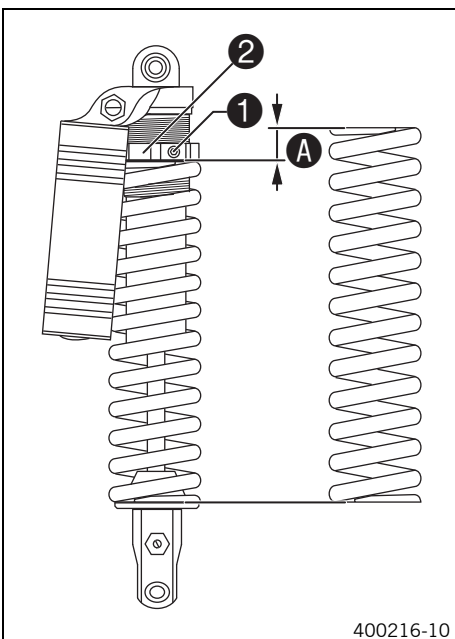

- Remove the shock absorber. 🛠️ (🔧 p. 55)
- After removing the shock absorber, clean it thoroughly.
- Loosen screw **1**.
- Turn adjusting ring **2** until the spring is no longer under tension.

Combination wrench (50329080000)
Hook wrench (T106S)

- Measure the overall spring length when not under tension.
- Tighten the spring by turning adjusting ring **2** to measurement **A**.

Guideline

(All 125/200 models)

Spring preload	6 mm (0.24 in)
----------------	----------------

(All 250/300 models)

Spring preload	8 mm (0.31 in)
----------------	----------------

i Info

Depending on the static sag and/or the riding sag, it may be necessary to increase or decrease the spring preload.

- Tighten screw **1**.

Guideline

Screw, shock absorber adjusting ring	M6	5 Nm (3.7 lbf ft)
--------------------------------------	----	-------------------

- Install the shock absorber. 🛠️ (🔧 p. 55)

Adjusting the riding sag 🛠️

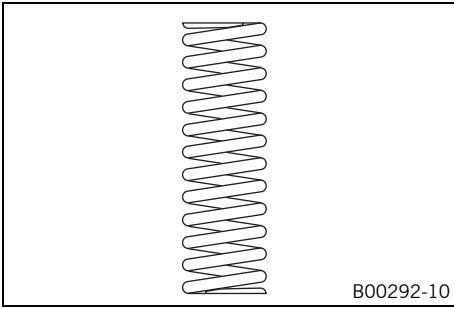

- Remove the shock absorber. 🛠️ (👉 p. 55)
- After removing the shock absorber, clean it thoroughly.
- Choose and mount a suitable spring.

Guideline

(All 125/200 models)

Spring rate	
Weight of rider: 65... 75 kg (143... 165 lb.)	63 N/mm (360 lb/in)
Weight of rider: 75... 85 kg (165... 187 lb.)	66 N/mm (377 lb/in)
Weight of rider: 85... 95 kg (187... 209 lb.)	69 N/mm (394 lb/in)

(All 250/300 models)

Spring rate	
Weight of rider: 65... 75 kg (143... 165 lb.)	66 N/mm (377 lb/in)
Weight of rider: 75... 85 kg (165... 187 lb.)	69 N/mm (394 lb/in)
Weight of rider: 85... 95 kg (187... 209 lb.)	72 N/mm (411 lb/in)

i Info

The spring rate is shown on the outside of the spring.

- Install the shock absorber. 🛠️ (👉 p. 55)
- Check the static sag of the shock absorber. (👉 p. 39)
- Check the riding sag of the shock absorber. (👉 p. 40)
- Adjust the rebound damping of the shock absorber. (👉 p. 38)

Checking the basic setting of the fork

i Info

For various reasons, no exact riding sag can be determined for the forks.

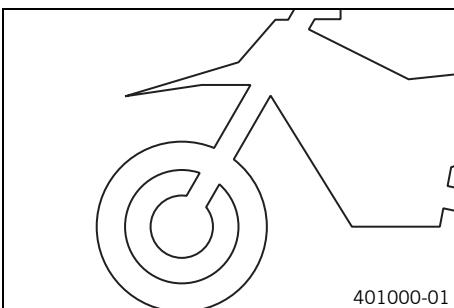

- As with the shock absorber, smaller differences in the rider's weight can be compensated by the spring preload.
- However, if the fork is often overloaded (hard end stop on compression), harder springs must be fit to avoid damage to the fork and frame.

Adjusting the compression damping of the fork

i Info

The hydraulic compression damping determines the fork suspension behavior.

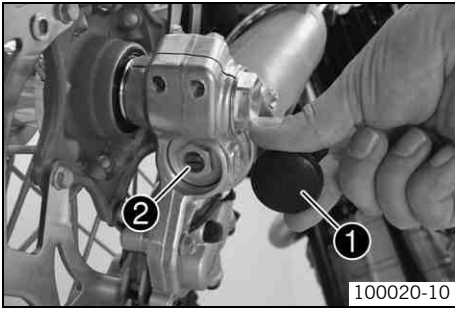

- Remove protection covers ❶.
- Turn adjusting screws ❷ clockwise all the way.

i Info
Adjusting screws ❷ are located at the bottom end of the fork legs. Make the same adjustment on both fork legs.

- Turn back counterclockwise by the number of clicks corresponding to the fork type.

Guideline

(All 125/200 models)

Compression damping	
Comfort	26 clicks
Standard	22 clicks
Sport	18 clicks

(All 250/300 models)

Compression damping	
Comfort	26 clicks
Standard	22 clicks
Sport	18 clicks

i Info
Turn clockwise to increase damping; turn counterclockwise to reduce damping.

- Mount protection covers ❶.

Adjusting the rebound damping of the fork

i Info
The hydraulic rebound damping determines the fork suspension behavior.

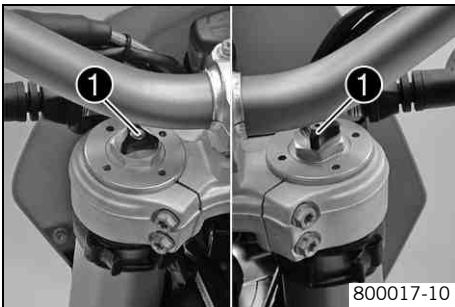

- Turn adjusting screws ❶ clockwise all the way.

i Info
Adjusting screws ❶ are located at the top end of the fork legs. Make the same adjustment on both fork legs.

- Turn back counterclockwise by the number of clicks corresponding to the fork type.

Guideline

(All 125/200 models)

Rebound damping	
Comfort	24 clicks
Standard	20 clicks
Sport	20 clicks

(All 250/300 models)

Rebound damping	
Comfort	24 clicks
Standard	20 clicks
Sport	20 clicks

i Info
Turn clockwise to increase damping; turn counterclockwise to reduce damping.

Adjusting the spring preload of the fork

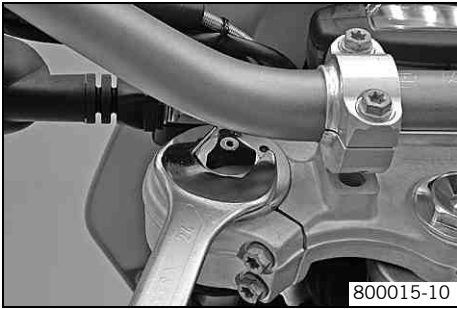

- Turn the adjusting screws counterclockwise all the way.



Info

Make the same adjustment on both fork legs.

- Turn back clockwise by the number of turns corresponding to the fork type.

Guideline

(All 125/200 models)

Spring preload - Preload Adjuster	
Comfort	0 turn
Standard	2 turns
Sport	4 turns

(All 250/300 models)

Spring preload - Preload Adjuster	
Comfort	0 turn
Standard	2 turns
Sport	4 turns



Info

Turn clockwise to increase spring preload; turn counterclockwise to reduce spring preload.

Adjusting the spring preload has no influence on the absorption setting of the rebound damping.

Basically, however, you should set the rebound damping higher with a higher spring preload.

Handlebar position

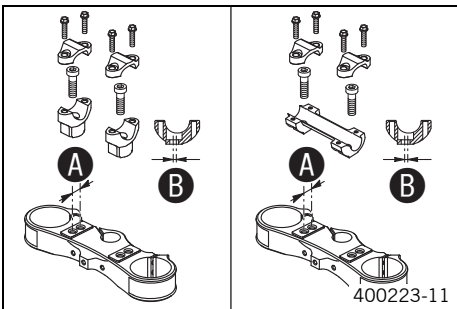

On the upper triple clamp, there are two holes a distance of **A** apart.

Hole distance A	15 mm (0.59 in)
-----------------	-----------------

The holes on the handlebar support are placed at a distance of **B** from the center.

Hole distance B	3.5 mm (0.138 in)
-----------------	-------------------

The handlebar can be mounted in four different positions. In this way, the handlebar can be mounted in the position that is most comfortable for the rider.

Adjusting the handlebar position



Warning

Danger of accidents Handlebar breakage.

- If the handlebar is bent or straightened it will cause material fatigue, and the handlebar can break. Always replace handlebar.

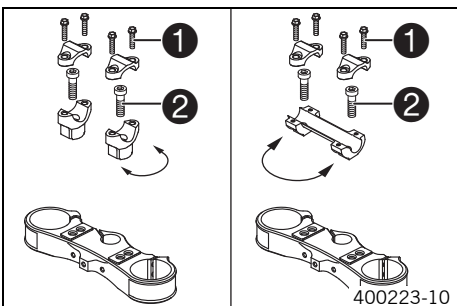

- Remove screws **1**. Remove the handlebar clamp. Remove the handlebar and lay it to one side.



Info

Protect the motorcycle and its attachments against damage by covering them.

Do not bend the cables and lines.

- Remove screws **2**. Remove the handlebar support.
- Place the handlebar support in the required position. Mount and tighten screws **2**.

Guideline

Screw, handlebar support	M10	40 Nm (29.5 lbf ft)	Loctite® 243™
--------------------------	-----	------------------------	---------------



Info

Position the left and right handlebar supports evenly.

- Position the handlebar.



Info

Make sure cables and wiring are positioned correctly.

- Position the handlebar clamp. Mount and tighten screws ①.

Guideline

Screw, handlebar clamp	M8	20 Nm (14.8 lbf ft)
------------------------	----	------------------------

Raising the motorcycle with the lift stand



Note

Danger of damage The parked vehicle may roll away or fall over.

- Always place the vehicle on a firm and even surface.
- Raise the motorcycle at the frame underneath the engine.

Lift stand (54829055000)

- ✓ The wheels must no longer touch the ground.
- Secure the motorcycle against falling over.

Removing the motorcycle from the lift stand

Note

Danger of damage The parked vehicle may roll away or fall over.

- Always place the vehicle on a firm and even surface.

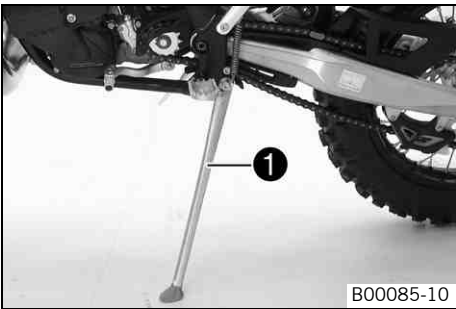

- Remove the motorcycle from the lift stand.
- Remove the lift stand.
- To park the motorcycle, press side stand ❶ to the ground with your foot and lean the motorcycle on it.

i Info

When you are riding, the side stand must be folded up and secured with the rubber band.

Bleeding the fork legs

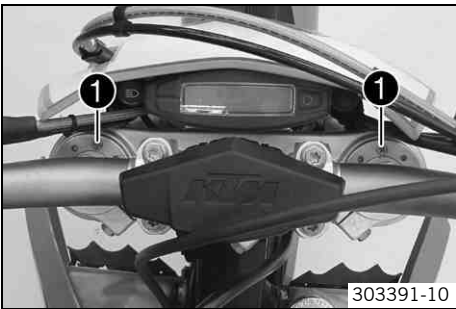

- Raise the motorcycle with the lift stand. (☛ p. 45)

(EXC, EXC Factory Edition, EXC SIX DAYS)

- Remove bleeder screws ❶ briefly.
 - ✓ Any excess pressure escapes from the interior of the fork.
- Mount and tighten bleeder screws.

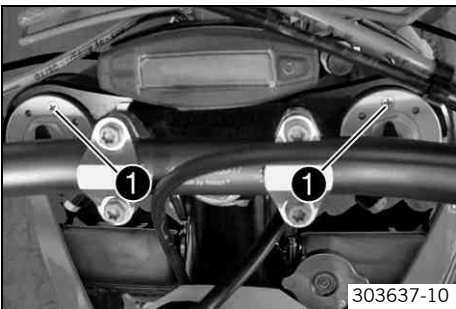

(XC-W)

- Remove bleeder screws ❶ briefly.
 - ✓ Any excess pressure escapes from the interior of the fork.
- Mount and tighten bleeder screws.
- Remove the motorcycle from the lift stand. (☛ p. 45)

Cleaning the dust boots of the fork legs

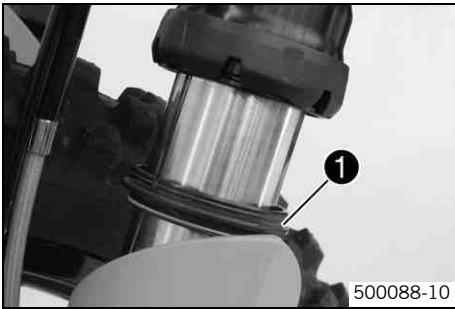

- Raise the motorcycle with the lift stand. (☞ p. 45)
- Loosen the fork protection. (☞ p. 46)
- Push dust boots 1 of both fork legs downwards.



Info

The dust boots should remove dust and coarse dirt particles from the fork tubes. Over time, dirt can penetrate behind the dust boots. If this dirt is not removed, the oil seals behind can start to leak.



Warning

Danger of accidents Reduced braking efficiency due to oil or grease on the brake discs.

- Always keep the brake discs free of oil and grease, and clean them with brake cleaner when necessary.

- Clean and oil the dust boots and inner fork tube of both fork legs.

Universal oil spray (☞ p. 128)

- Press the dust boots back into their normal position.
- Remove excess oil.
- Position the fork protection. (☞ p. 46)
- Remove the motorcycle from the lift stand. (☞ p. 45)

Loosening the fork protection



- Remove screws 1 and take off the clamp.
- Remove screws 2 on the left fork leg. Push the fork protection downwards.
- Remove the screws on the right fork leg. Push the fork protection downwards.

Positioning the fork protection



- Position the fork protection on the left fork leg. Mount and tighten screws 1.

Guideline

Remaining screws, chassis	M6	10 Nm (7.4 lbf ft)
---------------------------	----	--------------------

- Position the brake line. Position the clamp and mount and tighten screws 2.
- Position the fork protection on the right fork leg. Mount and tighten the screws.

Guideline

Remaining screws, chassis	M6	10 Nm (7.4 lbf ft)
---------------------------	----	--------------------

Removing the fork legs 🛠

(EXC, EXC Factory Edition, EXC SIX DAYS)

- Remove the headlight mask with the headlight. (☞ p. 85)
- Remove the front wheel. 🛠 (☞ p. 78)

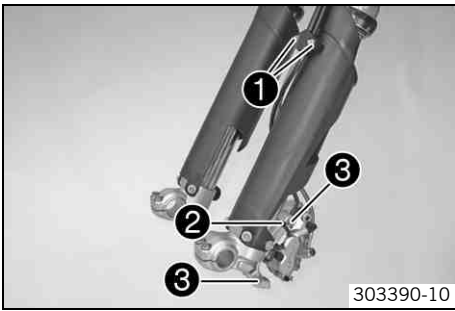

- Remove screws ❶ and take off the clamp.
- Remove cable binder ❷.
- Remove screws ❸ and take off the brake caliper.
- Hang the brake caliper and the brake line loosely to the side.

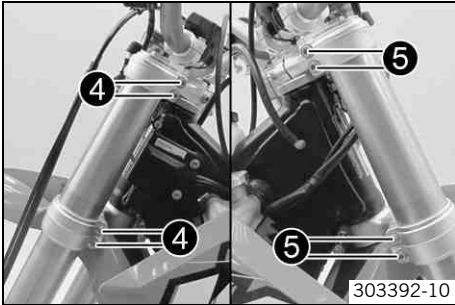

(EXC EU/AUS)

- Loosen screws ❹. Remove the fork leg on the left.
- Loosen screws ❺. Remove the fork leg on the right.

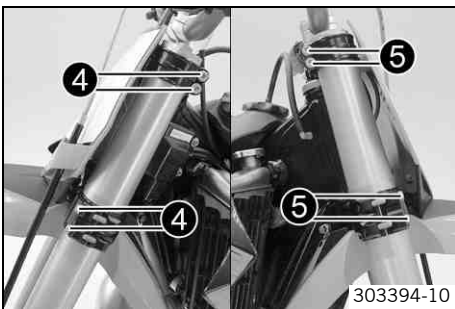

(EXC SIX DAYS, EXC Factory Edition, XC-W)

- Loosen screws ❹. Remove the fork leg on the left.
- Loosen screws ❺. Remove the fork leg on the right.

Installing the fork legs ↩

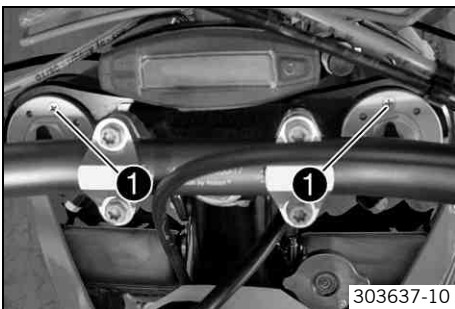

(XC-W)

- Position the fork legs.



Info

The upper milled groove in the fork leg must be flush with the top edge of the upper triple clamp. Position bleeder screws ❶ toward the front.

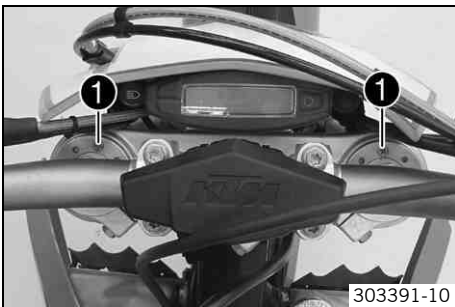

(EXC, EXC Factory Edition, EXC SIX DAYS)

- Position the fork legs.



Info

The upper milled groove in the fork leg must be flush with the top edge of the upper triple clamp. Position bleeder screws ❶ toward the front.

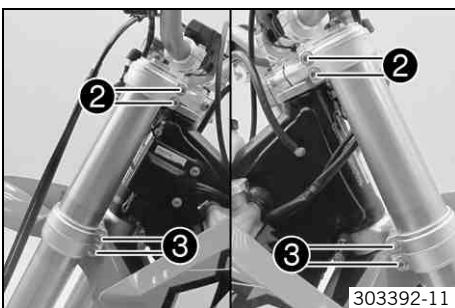

(EXC EU/AUS)

- Tighten screws ❷.

Guideline

Screw, top triple clamp	M8	20 Nm (14.8 lbf ft)
-------------------------	----	------------------------

- Tighten screws ❸.

Guideline

Screw, bottom triple clamp	M8	15 Nm (11.1 lbf ft)
----------------------------	----	------------------------

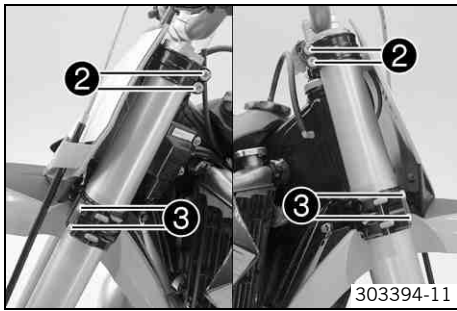

(EXC SIX DAYS, EXC Factory Edition, XC-W)

- Tighten screws 2.

Guideline

Screw, top triple clamp	M8	17 Nm (12.5 lbf ft)
-------------------------	----	------------------------

- Tighten screws 3.

Guideline

Screw, bottom triple clamp	M8	12 Nm (8.9 lbf ft)
----------------------------	----	-----------------------

- Position the brake caliper and mount and tighten screws 3.

Guideline

Screw, front brake caliper	M8	25 Nm (18.4 lbf ft)	Loctite® 243™
----------------------------	----	------------------------	----------------------

- Mount cable binder 4.
- Position the brake line and wiring harness. Put on the clamp and mount and tighten screws 5.
- Install the front wheel. (☛ (☛ p. 78)

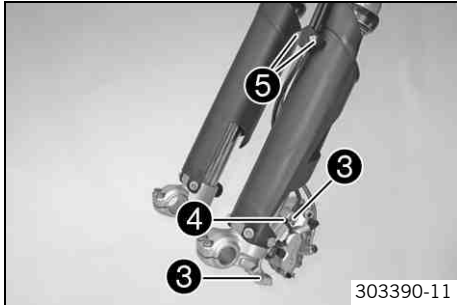

(EXC, EXC Factory Edition, EXC SIX DAYS)

- Refit the headlight mask with the headlight. (☛ p. 85)

Removing the fork protector ☛

- Remove the fork legs. (☛ (☛ p. 46)
- Remove screws 1 on the left fork leg. Lift off the fork protector.
- Remove the screws on the right fork leg. Lift off the fork protector.

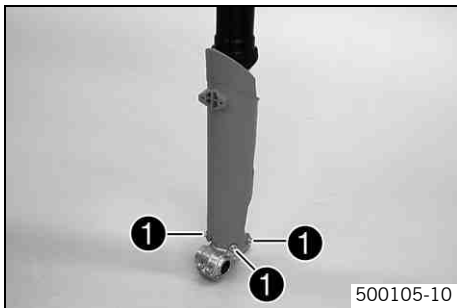

Installing the fork protector ☛

- Position the fork protection on the left fork leg. Mount and tighten screws 1.

Guideline

Remaining screws, chassis	M6	10 Nm (7.4 lbf ft)
---------------------------	----	--------------------

- Position the fork protection on the right fork leg. Mount and tighten the screws.

Guideline

Remaining screws, chassis	M6	10 Nm (7.4 lbf ft)
---------------------------	----	--------------------

- Install the fork legs. (☛ (☛ p. 47)

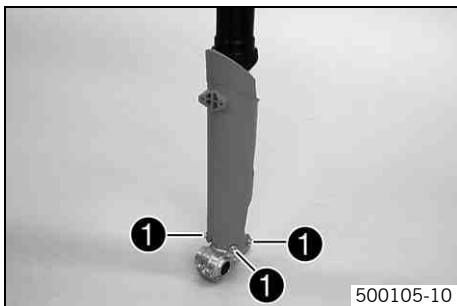

Removing the lower triple clamp ☛ (EXC EU/AUS)

- Remove the fork legs. (☛ (☛ p. 46)
- Remove the front fender. (☛ p. 54)
- Remove screws 1 and hang the CDI control unit to the side.

i Info
Do not unplug the CDI control unit.

- Remove screw 2. Loosen screw 3. Take off the top triple clamp with the handlebar and place it on one side.

i Info
Protect the motorcycle and its attachments against damage by covering them.
Do not bend the cables and lines.

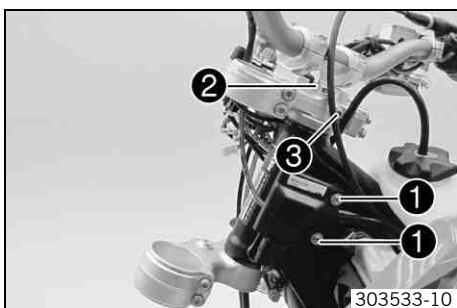

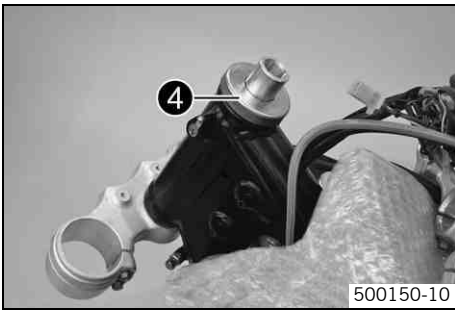

- Remove protective ring 4.
- Take out the lower triple clamp with the steering stem.
- Take out the upper steering head bearing.

Removing the lower triple clamp (EXC SIX DAYS, EXC Factory Edition, XC-W)

(XC-W)

- Remove the start number plate. (☞ p. 54)
- Remove the fork legs. (☞ p. 46)
- Remove the front fender. (☞ p. 54)
- Remove screws 1 and hang the CDI control unit to the side.

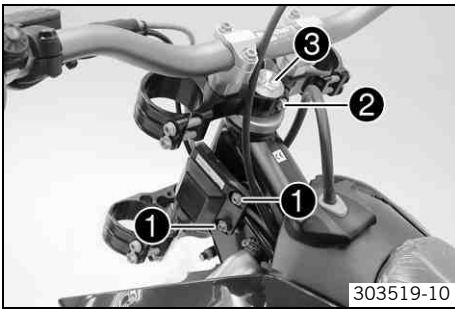

i Info
Do not unplug the CDI control unit.

- Remove screw 2. Remove screw 3, take off the top triple clamp with the handlebar and place it on one side.

i Info
Protect the motorcycle and its attachments against damage by covering them.
Do not bend the cables and lines.

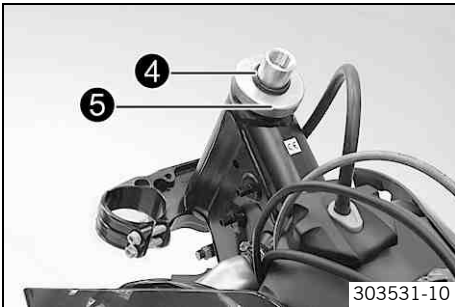

- Remove O-ring 4. Remove protective ring 5.
- Take out the lower triple clamp with the steering stem.
- Take out the upper steering head bearing.

Installing the lower triple clamp (EXC EU/AUS)

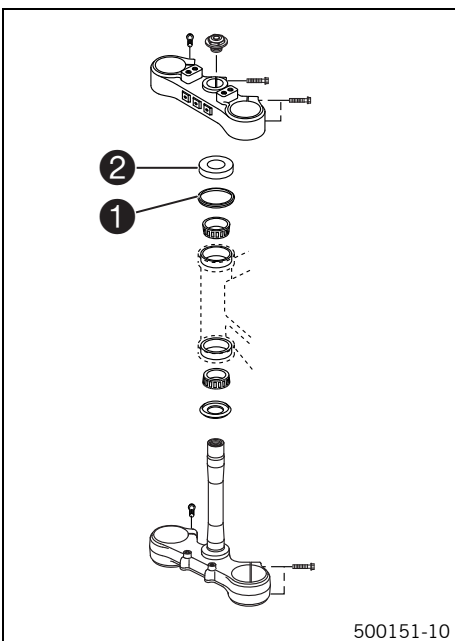

- Clean the bearing and sealing elements, check for damage, and grease.

High viscosity grease (☞ p. 127)

- Insert the lower triple clamp with the steering stem. Mount the upper steering head bearing.
- Check whether the top steering head seal 1 is correctly positioned.
- Push on protective ring 2.

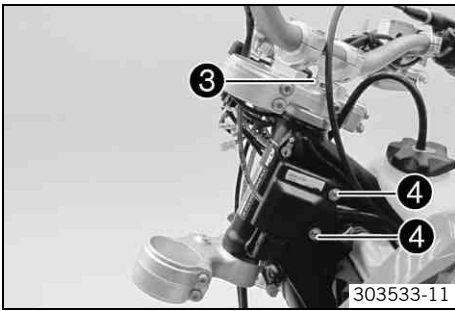

- Position the upper triple clamp with the steering.
- Mount screw ③ but do not tighten yet.
- Position the clutch line, wiring harness and CDI control unit. Mount and tighten screws ④.

Guideline

Remaining screws, chassis	M6	10 Nm (7.4 lbf ft)
---------------------------	----	--------------------

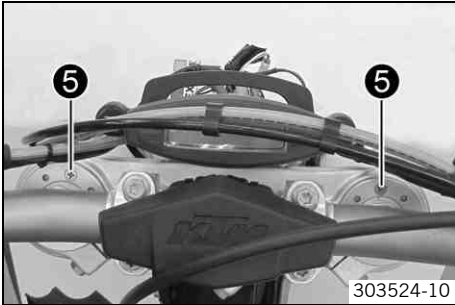

- Position the fork legs.

i Info

The upper milled groove in the fork leg must be flush with the top edge of the upper triple clamp.
Position bleeder screws ⑤ toward the front.

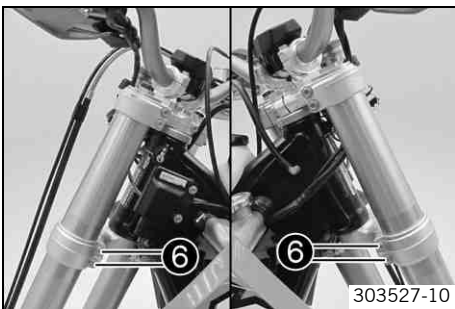

- Fully tighten screws ⑥.

Guideline

Screw, bottom triple clamp	M8	15 Nm (11.1 lbf ft)
----------------------------	----	------------------------

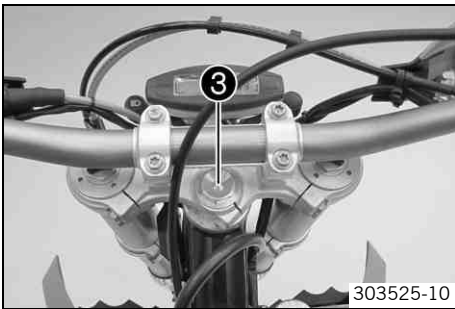

- Tighten screw ③.

Guideline

Screw, top steering head	M20x1.5	10 Nm (7.4 lbf ft)
--------------------------	---------	--------------------

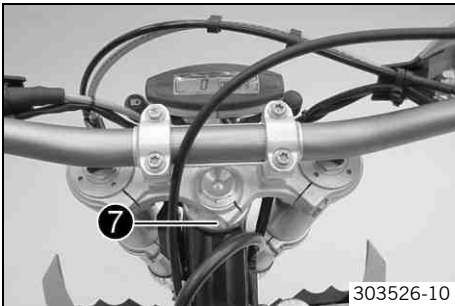

- Tighten screw ⑦.

Guideline

Screw, top steering stem	M8	20 Nm (14.8 lbf ft)
--------------------------	----	------------------------

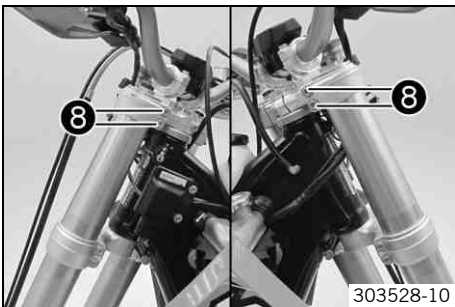

- Fully tighten screws ⑧.

Guideline

Screw, top triple clamp	M8	20 Nm (14.8 lbf ft)
-------------------------	----	------------------------

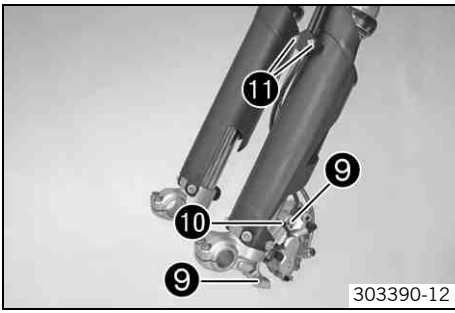

- Position the brake calipers. Mount and tighten screws 9.

Guideline

Screw, front brake caliper	M8	25 Nm (18.4 lbf ft)	Loctite® 243™
----------------------------	----	------------------------	---------------

- Mount cable clip 10.
- Position the brake line, wiring harness and clamp. Mount and tighten screws 11.
- Install the front fender. (☛ p. 55)
- Refit the headlight mask with the headlight. (☛ p. 85)
- Install the front wheel. ☛ (☛ p. 78)
- Check that the wiring harness, throttle cables and brake and clutch lines can move freely and are routed correctly.
- Check the play of the steering head bearing. (☛ p. 53)

Installing the lower triple clamp ☛ (EXC SIX DAYS, EXC Factory Edition, XC-W)

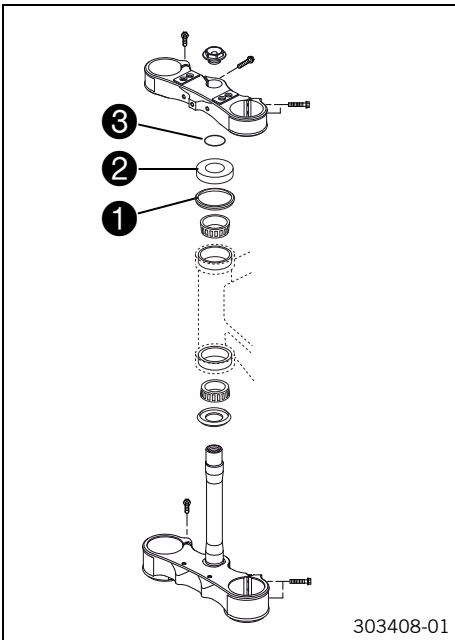

- Clean the bearing and sealing elements, check for damage, and grease.

High viscosity grease (☛ p. 127)

- Insert the lower triple clamp with the steering stem. Mount the upper steering head bearing.
- Check whether the top steering head seal 1 is correctly positioned.
- Push up protective ring 2 and O-ring 3.

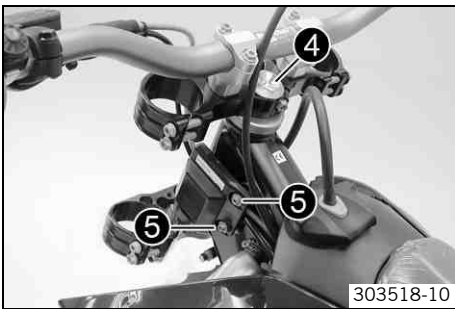

- Position the upper triple clamp with the steering.
- Mount screw 4 but do not tighten yet.
- Position the clutch line, wiring harness and CDI control unit. Mount and tighten screws 5.

Guideline

Remaining screws, chassis	M6	10 Nm (7.4 lbf ft)
---------------------------	----	--------------------



- Position the fork legs.

i Info

The upper milled groove in the fork leg must be flush with the top edge of the upper triple clamp.
Position bleeder screws 6 toward the front.

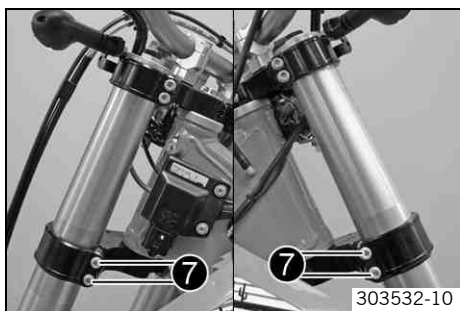

- Fully tighten screws 7.

Guideline

Screw, bottom triple clamp	M8	12 Nm (8.9 lbf ft)
----------------------------	----	--------------------



- Tighten screw 4.

Guideline

Screw, top steering head	M20x1.5	10 Nm (7.4 lbf ft)
--------------------------	---------	--------------------



- Mount and tighten screw 8.

Guideline

Screw, top steering stem	M8	17 Nm (12.5 lbf ft)	Loctite® 243™
--------------------------	----	------------------------	---------------

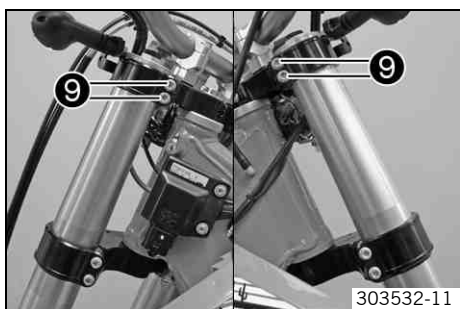

- Fully tighten screws 9.

Guideline

Screw, top triple clamp	M8	17 Nm (12.5 lbf ft)
-------------------------	----	------------------------

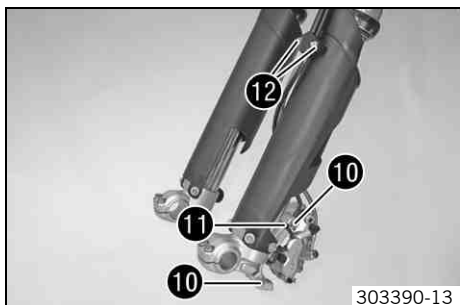

- Position the brake calipers. Mount and tighten screws 10.

Guideline

Screw, front brake caliper	M8	25 Nm (18.4 lbf ft)	Loctite® 243™
----------------------------	----	------------------------	---------------

- Mount cable clip 11.
- Position the brake line, wiring harness and clamp. Mount and tighten screws 12.
- Install the front fender. (☛ p. 55)

(EXC SIX DAYS, EXC Factory Edition)

- Refit the headlight mask with the headlight. (☛ p. 85)

(XC-W)

- Install the start number plate. (☛ p. 54)
- Install the front wheel. ☛ (☛ p. 78)
- Check that the wiring harness, throttle cables and brake and clutch lines can move freely and are routed correctly.
- Check the play of the steering head bearing. (☛ p. 53)

Checking the play of the steering head bearing



Warning

Danger of accidents Unstable vehicle handling from incorrect steering head bearing play.

- Adjust the steering head bearing play without delay. (Your authorized KTM workshop will be glad to help.)



Info

If the bike is ridden with play in the steering head bearing, the bearing and the bearing seats in the frame can become damaged over time.

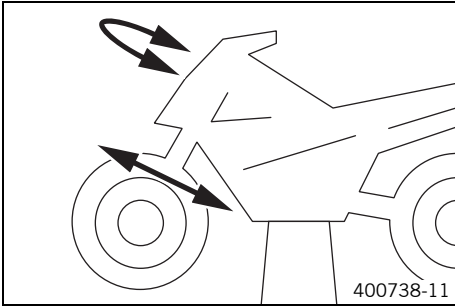

- Raise the motorcycle with the lift stand. (☛ p. 45)
- Move the handlebar to the straight-ahead position. Move the fork legs to and fro in the direction of travel.

No play should be noticeable in the steering head bearing.

- » If there is noticeable play present:
 - Adjust the play of the steering head bearing. ☛ (☛ p. 53)
- Move the handlebar to and fro over the entire steering range.

The handlebar must be able to move easily over the entire steering range. There should be no perceptible detent positions.

- » If detent positions are noticeable:
 - Adjust the play of the steering head bearing. ☛ (☛ p. 53)
 - Check the steering head bearing and replace if required.
- Remove the motorcycle from the lift stand. (☛ p. 45)

Adjusting the play of the steering head bearing ☛

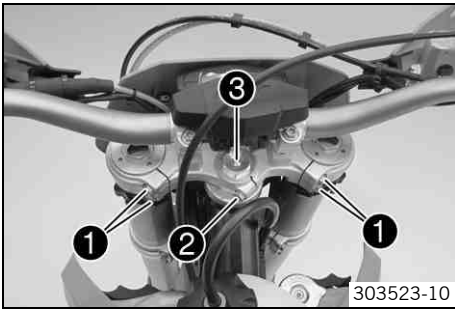

- Raise the motorcycle with the lift stand. (☛ p. 45)

(EXC EU/AUS)

- Loosen screws ❶ and ❷.
- Loosen and retighten screw ❸.

Guideline

Screw, top steering head	M20x1.5	10 Nm (7.4 lbf ft)
--------------------------	---------	-----------------------

- Using a plastic hammer, tap lightly on the upper triple clamp to avoid strains.
- Tighten screws ❶.

Guideline

Screw, top triple clamp	M8	20 Nm (14.8 lbf ft)
-------------------------	----	------------------------

- Tighten screw ❷.

Guideline

Screw, top steering stem	M8	20 Nm (14.8 lbf ft)
--------------------------	----	------------------------

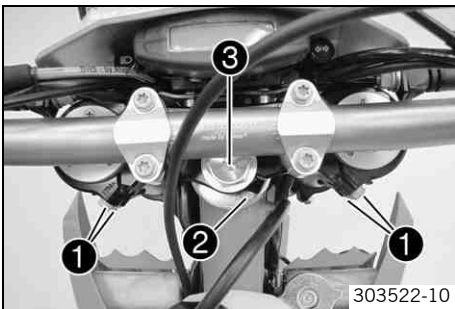

(EXC SIX DAYS, EXC Factory Edition, XC-W)

- Loosen screws ❶. Remove screw ❷.
- Loosen and retighten screw ❸.

Guideline

Screw, top steering head	M20x1.5	10 Nm (7.4 lbf ft)
--------------------------	---------	-----------------------

- Using a plastic hammer, tap lightly on the upper triple clamp to avoid strains.
- Tighten screws ❶.

Guideline

Screw, top triple clamp	M8	17 Nm (12.5 lbf ft)
-------------------------	----	------------------------

- Mount and tighten screw ②.

Guideline

Screw, top steering stem	M8	17 Nm (12.5 lbf ft)	Loctite® 243™
--------------------------	----	------------------------	---------------

- Check the play of the steering head bearing. (☞ p. 53)

Greasing the steering head bearing ☞

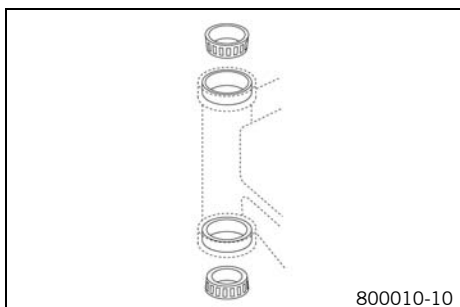

(EXC EU/AUS)

- Remove the lower triple clamp. ☞ (☞ p. 48)
- Install the lower triple clamp. ☞ (☞ p. 49)

(EXC SIX DAYS, EXC Factory Edition, XC-W)

- Remove the lower triple clamp. ☞ (☞ p. 49)
- Install the lower triple clamp. ☞ (☞ p. 51)

Removing the start number plate (XC-W)

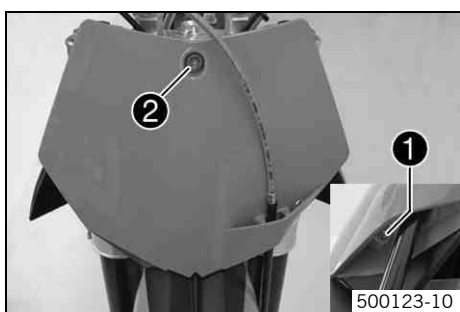

- Remove screw ① and take off the clamp.
- Remove screw ②. Remove the start number plate.

Installing the start number plate (XC-W)

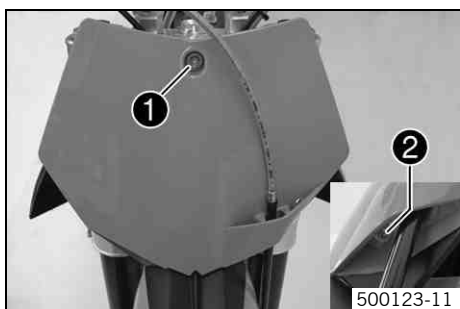

- Position the start number plate. Mount and tighten screw ①.

Guideline

Remaining screws, chassis	M6	10 Nm (7.4 lbf ft)
---------------------------	----	--------------------

i Info

Ensure that the holding lugs engage in the fender.

- Position the brake line. Put on the clamp and mount and tighten screw ②.

Removing the front fender

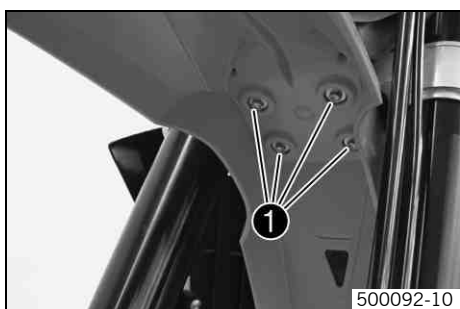

- Remove screws ①. Remove the front fender.
- Make sure the spacers remain in place.

Installing the front fender

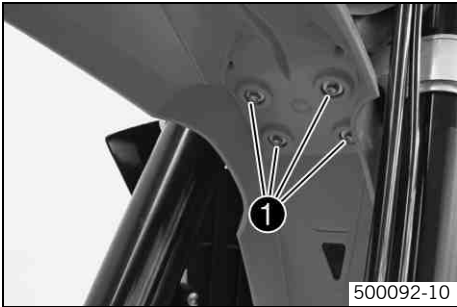

- Ensure that the spacers are mounted in the fender.
- Position the front fender. Mount and tighten screws ❶.

Guideline

Remaining screws, chassis	M6	10 Nm (7.4 lbf ft)
---------------------------	----	--------------------



Info

Make sure the holding lugs engage in the start number plate.

Removing the shock absorber

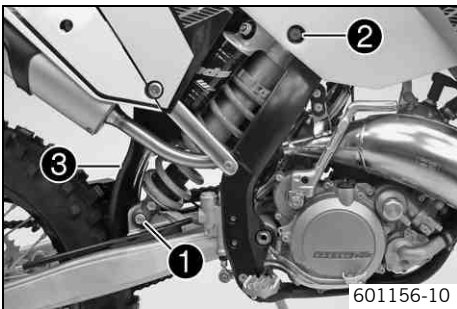

- Raise the motorcycle with the lift stand. (☛ p. 45)

(All 125/200 models)

- Remove screw ❶ and lower the rear wheel with the swing arm as far as possible without blocking the rear wheel. Fix the rear wheel in this position.
- Remove screw ❷, push splash protector ❸ to the side, and remove the shock absorber.

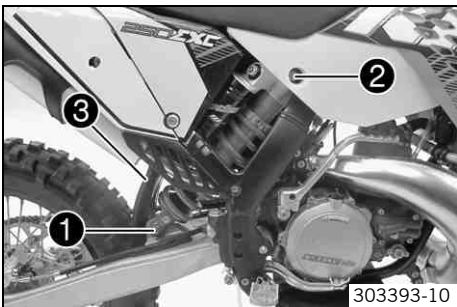

(All 250/300 models)

- Remove screw ❶ and lower the rear wheel with the swing arm as far as possible without blocking the rear wheel. Fix the rear wheel in this position.
- Remove screw ❷, push splash protector ❸ to the side, and remove the shock absorber.

Installing the shock absorber

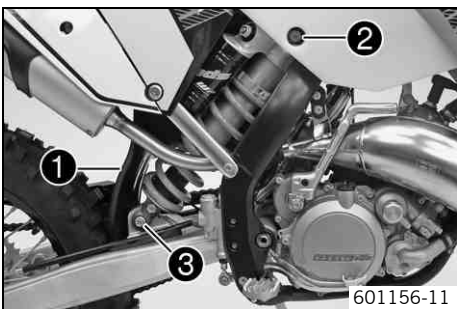

(All 125/200 models)

- Push splash protector ❶ to the side and position the shock absorber. Mount and tighten screw ❷.

Guideline

Screw, top shock absorber	M12	80 Nm (59 lbf ft)	Loctite® 2701
---------------------------	-----	-------------------	----------------------

- Mount and tighten screw ❸.

Guideline

Screw, bottom shock absorber	M12	80 Nm (59 lbf ft)	Loctite® 2701
------------------------------	-----	-------------------	----------------------



Info

The heim joint for the shock absorber at the swing arm is Teflon coated. It must not be lubricated with grease or with other lubricants. Lubricants dissolve the Teflon coating, thereby drastically reducing the service life.

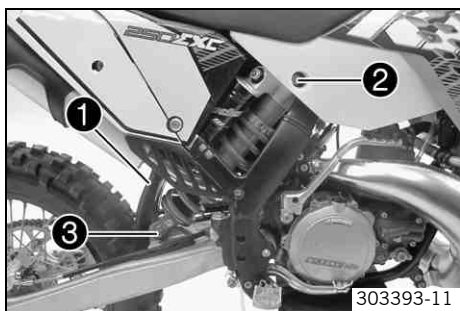

(All 250/300 models)

- Push splash protector ❶ to the side and position the shock absorber. Mount and tighten screw ❷.

Guideline

Screw, top shock absorber	M12	80 Nm (59 lbf ft)	Loctite® 2701
---------------------------	-----	----------------------	---------------

- Mount and tighten screw ❸.

Guideline

Screw, bottom shock absorber	M12	80 Nm (59 lbf ft)	Loctite® 2701
------------------------------	-----	----------------------	---------------



Info

The heim joint for the shock absorber at the swing arm is Teflon coated. It must not be lubricated with grease or with other lubricants. Lubricants dissolve the Teflon coating, thereby drastically reducing the service life.

- Remove the motorcycle from the lift stand. (☛ p. 45)

Removing the seat

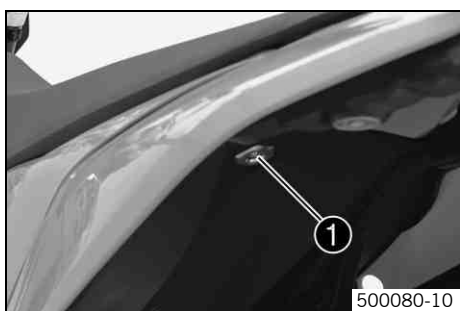

- Remove screw ❶. Lift up the seat at the rear, pull it back and then remove from above.

Mounting the seat



- Hook in the front of the seat at the collar bushing of the fuel tank, lower at the rear and simultaneously push forward.
- Make sure that the seat is correctly locked in.

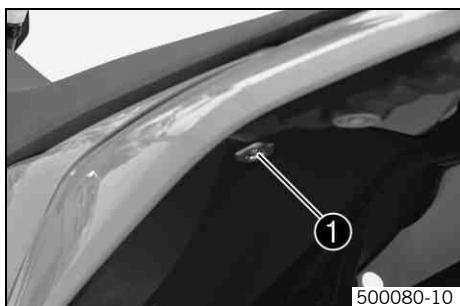

- Mount and tighten screw ❶ of the seat fixation.

Guideline

Remaining screws, chassis	M6	10 Nm (7.4 lbf ft)
---------------------------	----	--------------------

Removing the air filter box lid

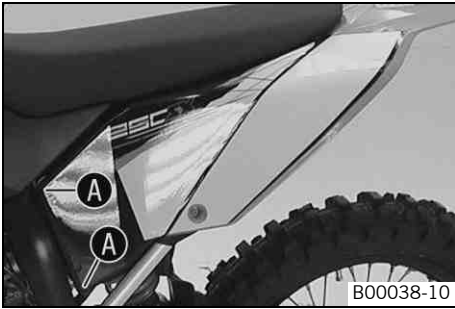

- Pull off the air filter box lid in area **A** sideways and remove it toward the front.

Installing the air filter box lid

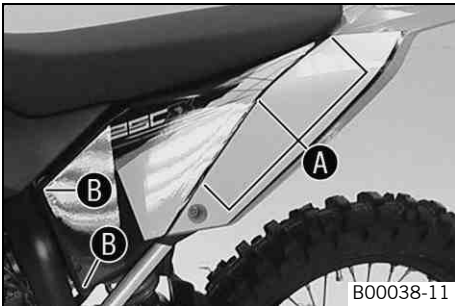

- Insert the air filter box lid into the rear area **A** and clip it into the front area **B**.

Removing the air filter

Note

Engine failure Unfiltered intake air has a negative effect on the service life of the engine.

- Never ride the vehicle without an air filter since dust and dirt can get into the engine and result in increased wear.



Warning

Environmental hazard Hazardous substances cause environmental damage.

- Oil, grease, filters, fuel, cleaners, brake fluid, etc., should be disposed of as stipulated in applicable regulations.



- Remove the air filter box lid. (☛ p. 57)
- Detach air filter holder **1** at the bottom and swing it to one side. Remove the air filter with the air filter support.
- Remove the air filter from the air filter support.

Installing the air filter

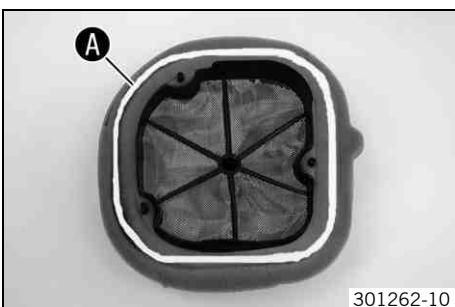

- Mount the clean air filter onto the air filter support.
- Grease the air filter in area **A**.

Long-life grease (☛ p. 127)

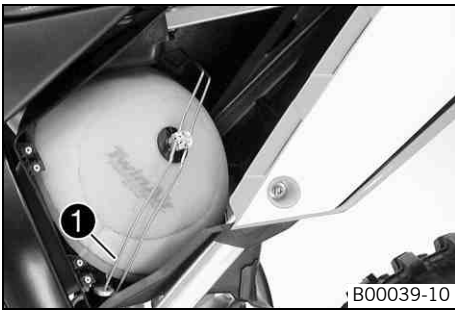

- Put in both parts together, position them, and fix them with air filter holder ❶.

i Info

If the air filter is not correctly mounted, dust and dirt can penetrate into the engine and can cause damage.

- Install the air filter box lid. (☞ p. 57)

Cleaning the air filter and air filter box 🗑️



Warning

Environmental hazard Hazardous substances cause environmental damage.

- Oil, grease, filters, fuel, cleaners, brake fluid, etc., should be disposed of as stipulated in applicable regulations.



Info

Do not clean the air filter with fuel or petroleum since these substances attack the foam.



- Remove the air filter. 🗑️ (☞ p. 57)
- Wash the air filter thoroughly in special cleaning liquid and allow it to dry properly.

Air filter cleaner (☞ p. 127)

i Info

Only press the air filter to dry it; never wring it out.

- Oil the dry air filter with a high quality filter oil.

Oil for foam air filter (☞ p. 127)

- Clean the air filter box.
- Clean the intake flange and check it for damage and tightness.
- Install the air filter. 🗑️ (☞ p. 57)

Removing the main silencer



Warning

Danger of burns The exhaust system gets very hot when the vehicle is driven.

- Allow the exhaust system to cool down. Do not touch hot components.

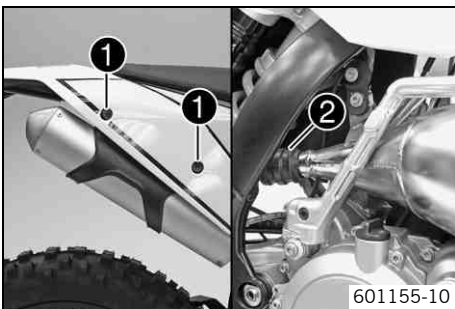

- Remove screws ❶.
- Pull the main silencer off of the manifold at the rubber sleeve ❷.

Installing the main silencer

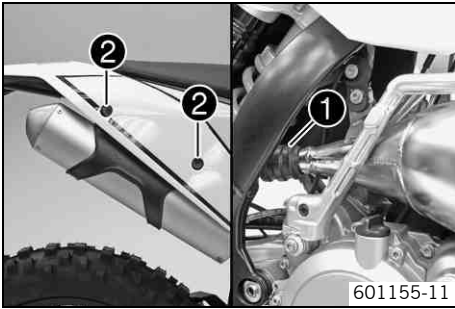

- Mount the main silencer with rubber sleeve ❶.
- Mount and tighten screws ❷.

Guideline

Remaining screws, chassis	M6	10 Nm (7.4 lbf ft)
---------------------------	----	--------------------

Changing the glass fiber yarn filling of the main silencer



Warning

Danger of burns The exhaust system gets very hot when the vehicle is driven.

- Allow the exhaust system to cool down. Do not touch hot components.



Info

Over a period, the fibers of the insulating material vanish into the air, and the silencer "burns out". Not only is the noise level higher, the performance characteristic changes.

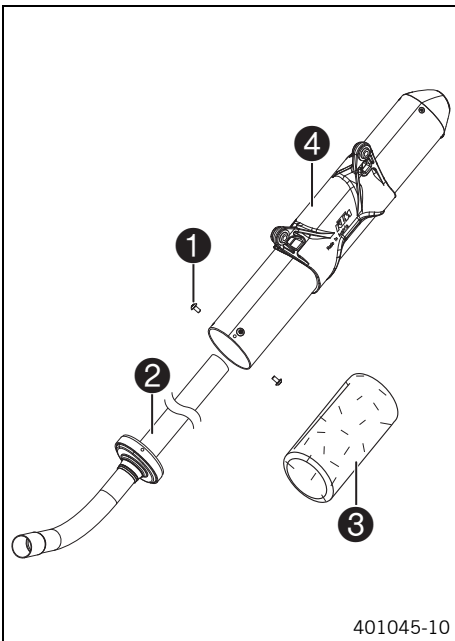

- Remove the main silencer. (☛ p. 58)
- Remove screws ❶. Pull out inner tube ❷.
- Pull the glass fiber yarn filling ❸ from the inner tube.
- Clean the parts that are to be reinstalled.
- Mount the new glass fiber yarn filling ❹ on the inner tube.
- Slide outer tube ❹ over the inner tube with the new glass fiber yarn filling.
- Mount and tighten all screws ❶.
- Install the main silencer. (☛ p. 59)

Removing the fuel tank



Danger

Fire hazard Fuel is highly flammable.

- Never refuel the vehicle near open flames or burning cigarettes, and always switch off the engine first. Be careful that no fuel is spilt, especially on hot vehicle components. Clean up spilt fuel immediately.
- Fuel in the fuel tank expands when warm and can escape if the tank is overfilled. See the notes on refueling.



Warning

Danger of poisoning Fuel is poisonous and a health hazard.

- Avoid contact between fuel and skin, eyes and clothing. Do not inhale fuel vapors. If fuel gets into your eyes, rinse immediately with water and contact a doctor. Wash affected skin areas immediately with soap and water. If fuel is swallowed, contact a doctor immediately. Change clothing that has come into contact with fuel. Store fuel in a suitable canister according to regulations and keep it out of the reach of children.

- Remove the seat. (☛ p. 56)

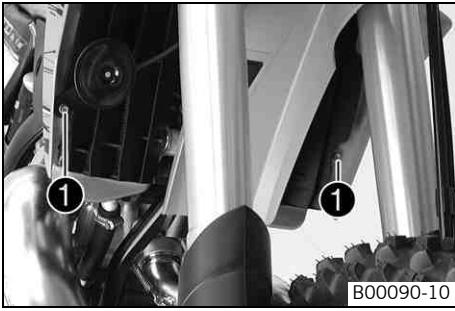

- Turn handle ❶ of the fuel tap to the **OFF** position. (Figure 601157-10 p. 22)
- Pull off the fuel hose.



Info

Remaining fuel may run out of the fuel hose.

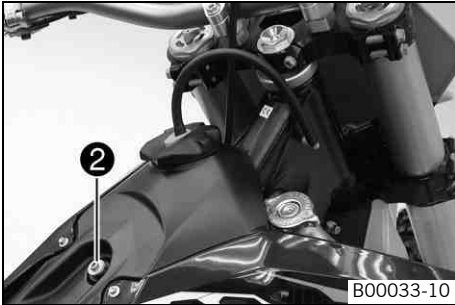

- Remove screws ❶ with the collar sleeve.
- (EXC, EXC Factory Edition, EXC SIX DAYS)**
 - Hang the horn and horn bracket to one side.

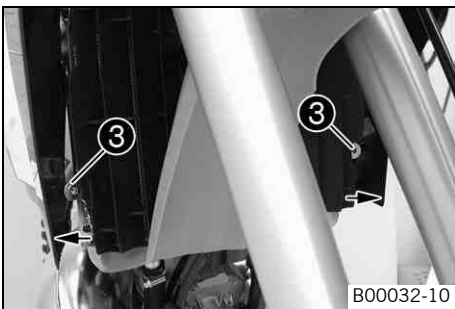

- Remove screw ❷ with the collar sleeve.
- Remove the tube from the fuel tank vent line.
- Pull both spoilers off of the sides of the radiator bracket ❸ and lift off the fuel tank.

Installing the fuel tank ↩



Danger

Fire hazard Fuel is highly flammable.

- Never refuel the vehicle near open flames or burning cigarettes, and always switch off the engine first. Be careful that no fuel is spilt, especially on hot vehicle components. Clean up spilt fuel immediately.
- Fuel in the fuel tank expands when warm and can escape if the tank is overfilled. See the notes on refueling.



Warning

Danger of poisoning Fuel is poisonous and a health hazard.

- Avoid contact of the fuel with skin, eyes and clothing. Do not inhale fuel vapors. If fuel gets into your eyes, rinse immediately with water and contact a doctor. Wash affected skin areas immediately with soap and water. If fuel is swallowed, contact a doctor immediately. Change clothing that has come into contact with fuel.



- Check the throttle cable routing. (p. 65)
- Position the fuel tank and fit the two spoilers to the sides of the radiator bracket.
- Make sure that no cables are trapped or damaged.



- Mount the fuel tank vent hose.
- Mount and tighten screw 1 with the collar sleeve.

Guideline

Remaining screws, chassis	M6	10 Nm (7.4 lbf ft)
---------------------------	----	--------------------

(EXC, EXC Factory Edition, EXC SIX DAYS)

- Position the horn with the horn bracket.

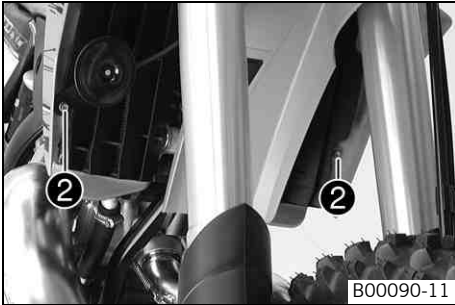

- Mount and tighten screws 2 with the collar sleeve.

Guideline

Remaining screws, chassis	M6	10 Nm (7.4 lbf ft)
---------------------------	----	--------------------

- Connect the fuel hose.
- Mount the seat. (☛ p. 56)

Checking the chain for dirt

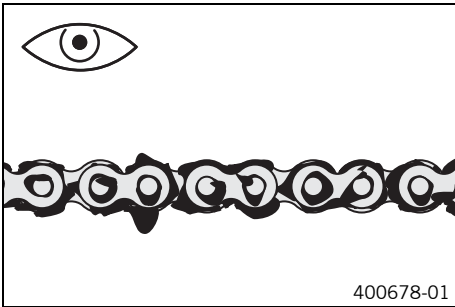

- Check the chain for heavy soiling.
 - » If the chain is very dirty:
 - Clean the chain. (☛ p. 61)

Cleaning the chain

Warning
Danger of accidents Oil or grease on the tires reduces their grip.
 - Remove oil and grease with a suitable cleaning material.

Warning
Danger of accidents Reduced braking efficiency due to oil or grease on the brake discs.
 - Always keep the brake discs free of oil and grease, and clean them with brake cleaner when necessary.

Warning
Environmental hazard Hazardous substances cause environmental damage.
 - Oil, grease, filters, fuel, cleaners, brake fluid, etc., should be disposed of as stipulated in applicable regulations.

i Info
 The service life of the chain depends largely on its maintenance.

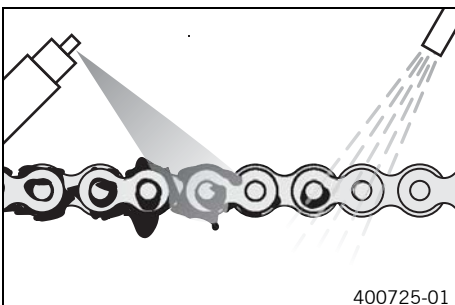

- Clean the chain regularly and then treat with chain spray.

Chain cleaner (☛ p. 127)
Off-road chain spray (☛ p. 127)

Checking the chain tension

Warning
Danger of accidents Danger caused by incorrect chain tension.

- If the chain tension is too high, the components of the secondary power train (chain, engine sprocket, rear sprocket, bearings in transmission and rear wheel) are under additional load. Apart from premature wear, in extreme cases the chain can rupture or the countershaft of the transmission can break. On the other hand, if the chain is loose, it can fall off the engine sprocket or the rear sprocket and block the rear wheel or damage the engine. Check the chain tension and correct if necessary.

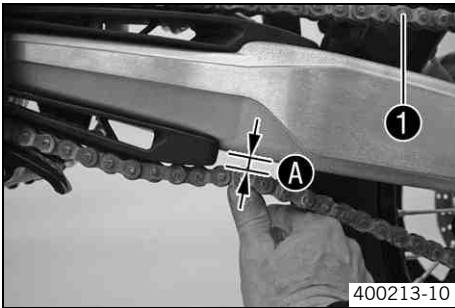

- Raise the motorcycle with the lift stand. (☛ p. 45)
- Push the chain at the end of the chain sliding component upwards to measure chain tension **A**.

i Info
 The upper chain section **1** must be taut.
 Chain wear is not always even, so you should repeat this measurement at different chain positions.

Chain tension	8... 10 mm (0.31... 0.39 in)
---------------	------------------------------

- » If the chain tension does not meet specifications:
 - Adjust the chain tension. (☛ p. 64)
- Remove the motorcycle from the lift stand. (☛ p. 45)

Checking the chain, rear sprocket, engine sprocket and chain guide

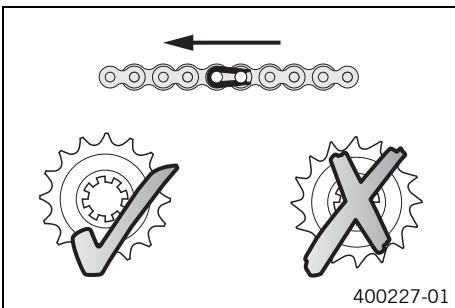

- Raise the motorcycle with the lift stand. (☛ p. 45)
- Shift gear to neutral.
- Check the rear sprocket and engine sprocket for wear.
 - » If the rear sprocket and engine sprocket are worn:
 - Change the rear sprocket or engine sprocket. ☛

i Info
 The engine sprocket, rear sprocket, and chain should always be changed together.

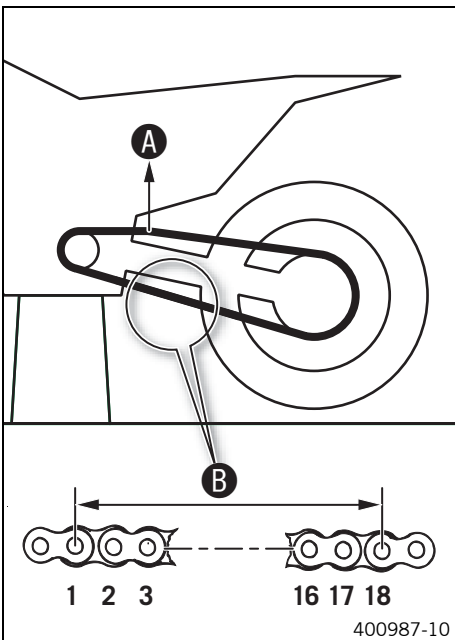

- Pull on the upper part of the chain with the specified weight **A**.

Guideline

Weight, chain wear measurement	10... 15 kg (22... 33 lb.)
--------------------------------	----------------------------

- Measure the distance **B** of 18 chain links in the lower chain section.

i Info
 Chain wear is not always even; repeat this measurement at different chain positions.

Maximum distance B at the longest chain section	272 mm (10.71 in)
--	-------------------

- » If the distance **B** is greater than the specified measurement:
 - Change the chain. ☛

i Info
 When you replace the chain, you should also change the rear sprocket and engine sprocket.
 New chains wear out faster on old, worn sprockets.



- Check the chain sliding guard for wear.
 - » If the lower edge of the chain pins is in line with or below the chain sliding guard:
 - Change the chain sliding guard. 🛠️
- Check the chain sliding guard for tightness.
 - » If the chain sliding guard is loose:
 - Tighten the chain sliding guard.

Guideline

Screw, chain sliding guard	M6	6 Nm (4.4 lbf ft)	Loctite® 243™
----------------------------	----	----------------------	----------------------



- Check the chain sliding piece for wear.
 - » If the lower edge of the chain pins is in line with or below the chain sliding piece:
 - Change the chain sliding piece. 🛠️
- Check the chain sliding piece for tightness.
 - » If the chain sliding piece is loose:
 - Tighten the chain sliding piece.

Guideline

Screw, chain sliding piece	M8	15 Nm (11.1 lbf ft)	
----------------------------	----	------------------------	--

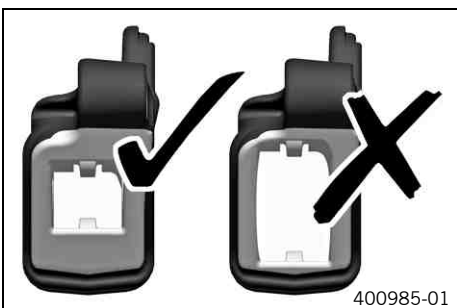

- Check the chain guide for wear.



Info

Wear can be seen on the front of the chain guide.

- » If the light part of the chain guide is worn:
 - Change the chain guide. 🛠️

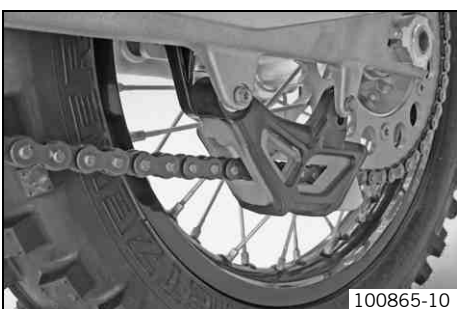

- Check the chain guide for tightness.
 - » If the chain guide is loose:
 - Tighten the chain guide.

Guideline

Remaining screws, chassis	M6	10 Nm (7.4 lbf ft)	
Remaining nuts, chassis	M6	15 Nm (11.1 lbf ft)	

- Remove the motorcycle from the lift stand. (🔧 p. 45)

Adjusting the chain tension

- Warning**
Danger of accidents Danger caused by incorrect chain tension.
- If the chain tension is too high, the components of the secondary power train (chain, engine sprocket, rear sprocket, bearings in transmission and rear wheel) are under additional load. Apart from premature wear, in extreme cases the chain can rupture or the countershaft of the transmission can break. On the other hand, if the chain is loose, it can fall off the engine sprocket or the rear sprocket and block the rear wheel or damage the engine. Check the chain tension and correct if necessary.

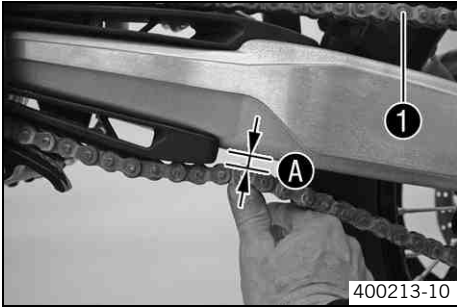

- Raise the motorcycle with the lift stand. (☛ p. 45)
- Push the chain at the end of the chain sliding component upwards to measure the chain tension **A**.

i Info
 The upper chain section **1** must be taut.
 Chain wear is not always even, so you should repeat this measurement at different chain positions.

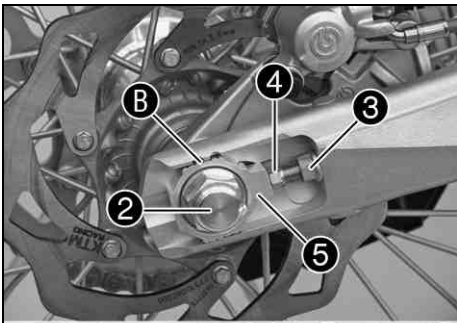

- Loosen nut **2**.
- Loosen nuts **3**.
- Adjust the chain tension by turning the adjusting screws **4** left and right.

Guideline

Chain tension	8... 10 mm (0.31... 0.39 in)	
Turn adjusting screws 4 on the left and right so that the markings on the left and right chain adjusters are in the same position relative to the reference marks B . The rear wheel is then correctly aligned.		

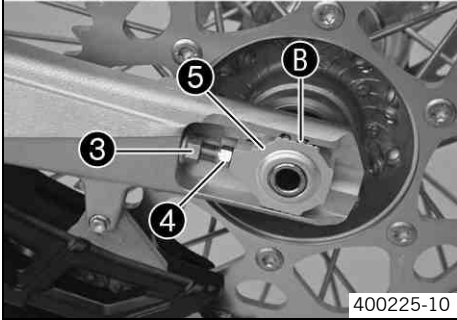

- Tighten nuts **3**.
- Make sure that chain adjusters **5** are fitted correctly on adjusting screws **4**.
- Tighten nut **2**.

Guideline

Nut, rear wheel spindle	M20x1.5	80 Nm (59 lbf ft)
-------------------------	---------	-------------------

i Info
 The wide adjustment range of the chain adjusters (32 mm (1.18 in)) enables different secondary ratios with the same chain length.
 Chain adjusters **5** can be turned by 180°.

- Remove the motorcycle from the lift stand. (☛ p. 45)

Adjusting the chain guide

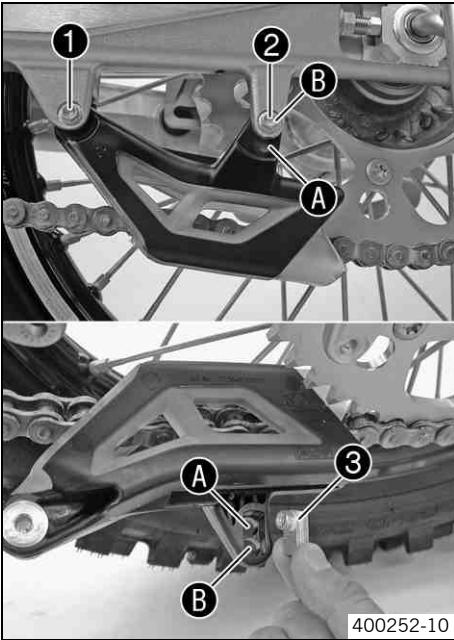

- Remove the nut of screw ❶.
- Remove screws ❶ and ❷. Take off the chain guide.

Condition

Number of teeth: ≤ 44 teeth

- Insert nut ❸ in hole ❶. Position the chain guide.
- Mount and tighten screws ❶ and ❷.

Guideline

Remaining screws, chassis	M6	10 Nm (7.4 lbf ft)
---------------------------	----	-----------------------

- Mount the nut on screw ❶ and tighten.

Guideline

Remaining nuts, chassis	M6	15 Nm (11.1 lbf ft)
-------------------------	----	------------------------

Condition

Number of teeth: ≥ 45 teeth

- Insert nut ❸ in hole ❷. Position the chain guide.
- Mount and tighten screws ❶ and ❷.

Guideline

Remaining screws, chassis	M6	10 Nm (7.4 lbf ft)
---------------------------	----	-----------------------

- Mount the nut on screw ❶ and tighten.

Guideline

Remaining nuts, chassis	M6	15 Nm (11.1 lbf ft)
-------------------------	----	------------------------

Checking the throttle cable routing



- Remove the fuel tank. (☞ p. 59)

(All 125/200 models)

- Check the throttle cable routing.

The throttle cable must be routed to the carburetor on the left side of the upper frame tube behind the handlebars.

- » If the throttle cable is not routed as specified:
 - Correct the throttle cable routing.



(All 250/300 models)

- Check the throttle cable routing.

The throttle cable must be routed to the carburetor on the left side of the upper frame tube behind the handlebars.

- » If the throttle cable is not routed as specified:
 - Correct the throttle cable routing.
- Install the fuel tank. 🛠️ (📄 p. 60)

Adjusting the basic position of the clutch lever

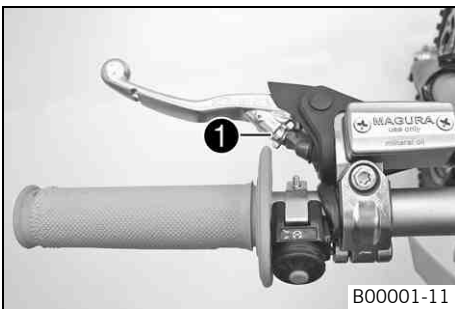

(All 125/200 models)

- Adjust the basic setting of the clutch lever to your hand size by turning adjusting screw ❶.

i Info
 Turn the adjusting screw counterclockwise to increase the distance between the clutch lever and the handlebar.
 Turn the adjusting screw clockwise to decrease the distance between the clutch lever and the handlebar.
 The range of adjustment is limited.
 Turn the adjusting screw by hand only, and do not apply any force.
 Do not make any adjustments while riding!

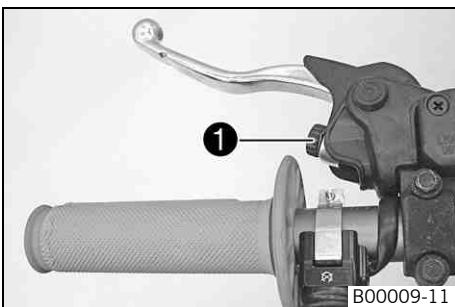

(All 250/300 models)

- Adjust the basic setting of the clutch lever to your hand size by turning adjusting screw ❶.

i Info
 Turn the adjusting screw counterclockwise to decrease the distance between the clutch lever and the handlebar.
 Turn the adjusting screw clockwise to increase the distance between the clutch lever and the handlebar.
 The range of adjustment is limited.
 Turn the adjusting screw by hand only, and do not apply any force.
 Do not make any adjustments while riding!

Checking the fluid level of the hydraulic clutch

i Info
 The fluid level rises with increasing wear of the clutch lining discs.

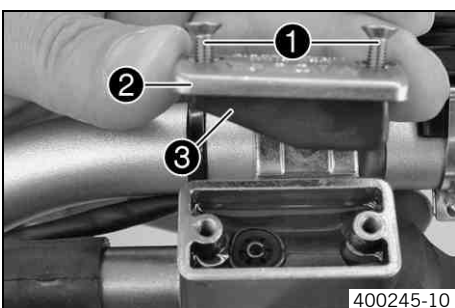

(All 125/200 models)

- Move the clutch fluid reservoir mounted on the handlebar to a horizontal position.
- Remove screws ❶.
- Remove cover ❷ with membrane ❸.
- Check the fluid level.

Fluid level under top edge of container	4 mm (0.16 in)
---	----------------

- » If the level of the fluid does not meet specifications:
 - Correct the fluid level of the hydraulic clutch.

Hydraulic fluid (15) (☛ p. 126)

- Position the cover with the membrane. Mount and tighten the screws.

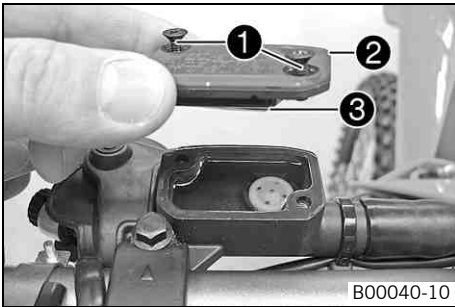

(All 250/300 models)

- Move the clutch fluid reservoir mounted on the handlebar to a horizontal position.
- Remove screws ①.
- Remove cover ② with membrane ③.
- Check the fluid level.

Fluid level under top edge of container	4 mm (0.16 in)
---	----------------

- » If the level of the fluid does not meet specifications:
 - Correct the fluid level of the hydraulic clutch.

Brake fluid DOT 4 / DOT 5.1 (☛ p. 125)

- Position the cover with the membrane. Mount and tighten the screws.

Changing the hydraulic clutch fluid ☛

Warning
Environmental hazard Hazardous substances cause environmental damage.

- Oil, grease, filters, fuel, cleaners, brake fluid, etc., should be disposed of as stipulated in applicable regulations.

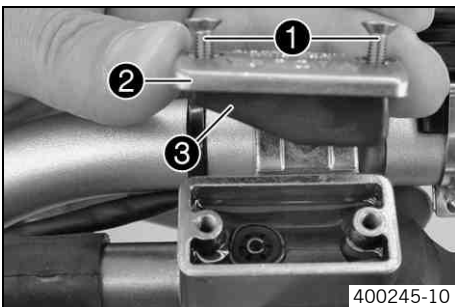

(All 125/200 models)

- Move the clutch fluid reservoir mounted on the handlebar to a horizontal position.
- Remove screws ①.
- Remove cover ② with membrane ③.

- Fill bleeding syringe ④ with the appropriate hydraulic fluid.

Bleed syringe (50329050000)	
Hydraulic fluid (15) (☛ p. 126)	

- On the slave cylinder, remove bleeder screw ⑤ and mount bleeding syringe ④.

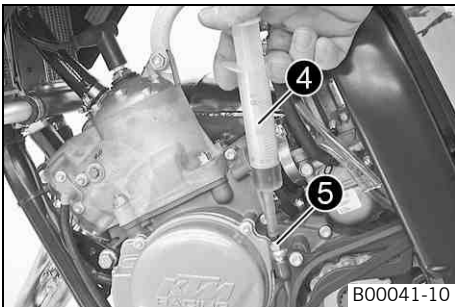

- Inject the liquid into the system until it escapes from hole ⑥ of the master cylinder without bubbles.
- To prevent overflow, drain fluid occasionally from the master cylinder reservoir.
- Remove the bleeding syringe. Mount and tighten the bleeder screw.
- Correct the fluid level of the hydraulic clutch.

Guideline

Fluid level under top edge of container	4 mm (0.16 in)
---	----------------

- Position the cover with the membrane. Mount and tighten the screws.

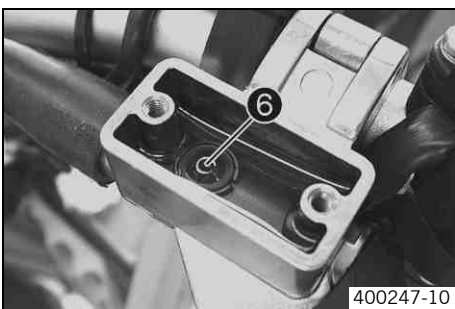

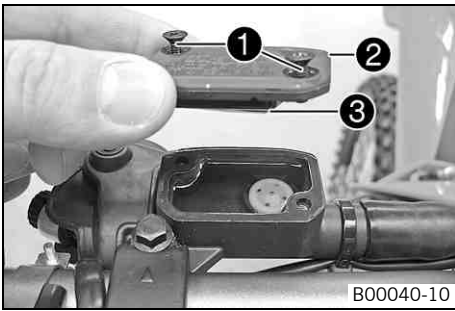

(All 250/300 models)

- Move the clutch fluid reservoir mounted on the handlebar to a horizontal position.
- Remove screws ①.
- Remove cover ② with membrane ③.

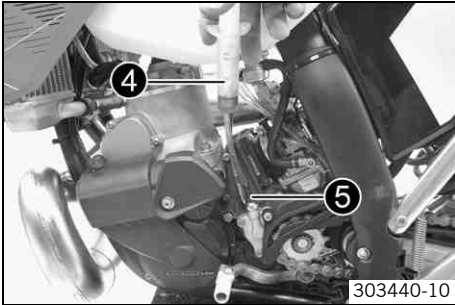

- Fill bleeding syringe ④ with the appropriate hydraulic fluid.

Bleed syringe (50329050000)
Brake fluid DOT 4 / DOT 5.1 (☛ p. 125)

- On the slave cylinder, remove bleeder screw ⑤ and mount bleeding syringe ④.

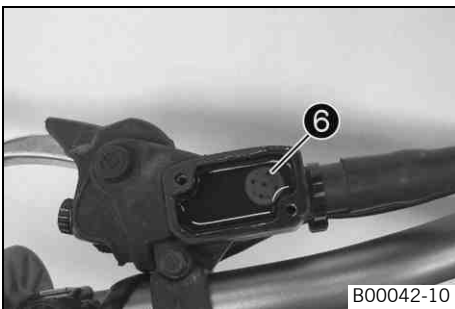

- Inject the liquid into the system until it escapes from hole ⑥ of the master cylinder without bubbles.
- To prevent overflow, drain fluid occasionally from the master cylinder reservoir.
- Remove the bleeding syringe. Mount and tighten the bleeder screw.
- Correct the fluid level of the hydraulic clutch.

Guideline

Fluid level under top edge of container	4 mm (0.16 in)
---	----------------

- Position the cover with the membrane. Mount and tighten the screws.

Checking free travel of hand brake lever



Warning

Danger of accidents Brake system failure.

- If there is no free travel on the hand brake lever, pressure builds up in the front brake circuit. The front brake can fail due to overheating. Adjust free travel on hand brake lever according to specifications.

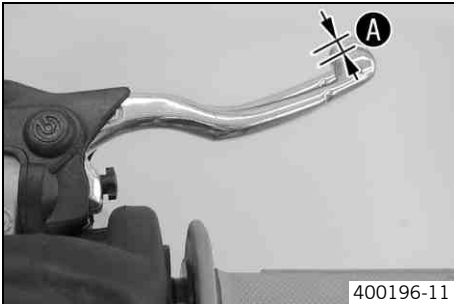

400196-11

(XC-W)

- Push the hand brake lever forwards and check free travel **A**.

Free travel of hand brake lever	$\geq 3 \text{ mm } (\geq 0.12 \text{ in})$
---------------------------------	---

- » If the free travel does not meet specifications:
 - Adjust the basic position of the hand brake lever. (☛ p. 69)



400196-13

(EXC, EXC Factory Edition, EXC SIX DAYS)

- Push the hand brake to the handlebar and check free travel **A**.

Free travel of hand brake lever	$\geq 3 \text{ mm } (\geq 0.12 \text{ in})$
---------------------------------	---

- » If the free travel does not meet specifications:
 - Adjust the free travel of the hand brake lever. (☛ p. 69)

Adjusting the basic position of the hand brake lever (XC-W)

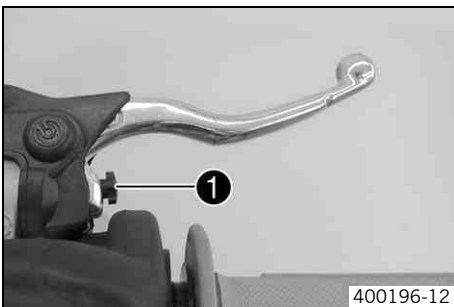

400196-12

- Check the free travel of the hand brake lever. (☛ p. 69)
- Adjust the basic setting of the hand brake lever to your hand size by turning adjusting screw **1**.



Info

Turn the adjusting screw clockwise to increase the distance between the hand brake lever and the handlebar.
Turn the adjusting screw counterclockwise to decrease the distance between the hand brake lever and the handlebar.
The range of adjustment is limited.
Turn the adjusting screw by hand only, and do not apply any force.
Do not make any adjustments while riding!

Adjusting free travel of hand brake lever (EXC, EXC Factory Edition, EXC SIX DAYS)

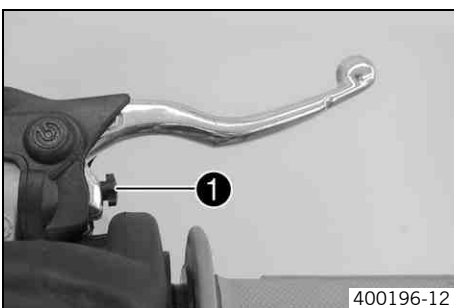

400196-12

- Check the free travel of the hand brake lever. (☛ p. 69)
- Adjust the free travel of the hand brake lever with the adjustment screw **1**.



Info

Turn the adjustment screw clockwise to reduce free travel. The pressure point moves away from the handlebar.
Turn the adjustment screw counterclockwise to increase free travel. The pressure point moves towards the handlebar.
The range of adjustment is limited.
Turn the adjusting screw by hand only, and do not apply any force.
Do not make any adjustments while riding!

Checking the brake discs



Warning

Danger of accidents Reduced braking efficiency due to worn brake disc(s).

- Change the worn brake disc(s) without delay. (Your authorized KTM workshop will be glad to help.)

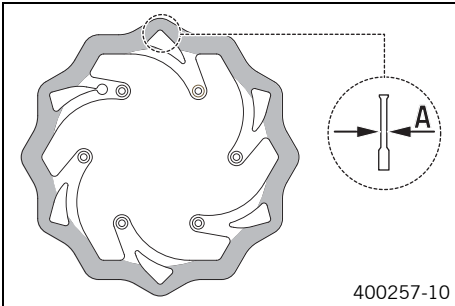

- Check the thickness of the front and rear brake discs at several places on the disc to see if it conforms to measurement **A**.



Info

Wear reduces the thickness of the brake disc around the area used by the brake linings.

Brake discs - wear limit	
Front	2.5 mm (0.098 in)
Rear	3.5 mm (0.138 in)

- » If the brake disc thickness is less than the specified value:
 - Change the brake disc.
- Check the front and rear brake discs for damage, cracking and deformation.
 - » If the brake disc exhibits damage, cracking or deformation:
 - Change the brake disc.

Checking the front brake fluid level



Warning

Danger of accidents Failure of the brake system.

- If the brake fluid level falls below the **MIN** mark, this indicates a leakage in the brake system or worn-out brake linings. Check the brake system and do not continue riding. (Your authorized KTM workshop will be glad to help.)



Warning

Danger of accidents Reduced braking effect caused by old brake fluid.

- Change the brake fluid of the front and rear brake according to the service schedule. (Your authorized KTM workshop will be glad to help.)

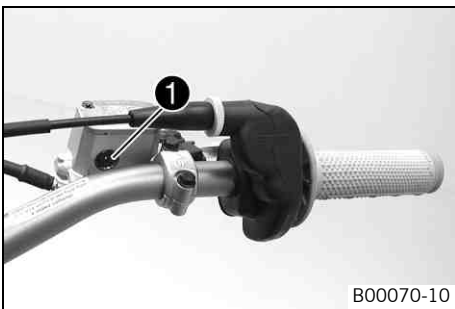

- Move the brake fluid reservoir mounted on the handlebar to a horizontal position.
- Check the brake fluid level in the viewer **1**.
 - » If the brake fluid is below the **MIN** marking:
 - Add front brake fluid. 🛠️ (📄 p. 70)

Adding front brake fluid 🛠️



Warning

Danger of accidents Failure of the brake system.

- If the brake fluid level falls below the **MIN** mark, this indicates a leakage in the brake system or worn-out brake linings. Check the brake system and do not continue riding. (Your authorized KTM workshop will be glad to help.)



Warning

Skin irritation Brake fluid can cause skin irritation on contact.

- Avoid contact with skin and eyes, and keep out of the reach of children.
- Wear suitable protective clothing and goggles.
- If brake fluid comes into contact with the eyes, flush the eyes thoroughly with water and consult a physician immediately.

- Warning**
Danger of accidents Reduced braking effect caused by old brake fluid.
- Change the brake fluid of the front and rear brake according to the service schedule. (Your authorized KTM workshop will be glad to help.)

- Warning**
Environmental hazard Hazardous substances cause environmental damage.
- Oil, grease, filters, fuel, cleaners, brake fluid, etc., should be disposed of as stipulated in applicable regulations.

- Info**
- Never use DOT 5 brake fluid! It is silicone-based and purple in color. Oil seals and brake lines are not designed for DOT 5 brake fluid.
 Avoid contact between brake fluid and painted parts. Brake fluid attacks paint!
 Use only clean brake fluid from a sealed container!

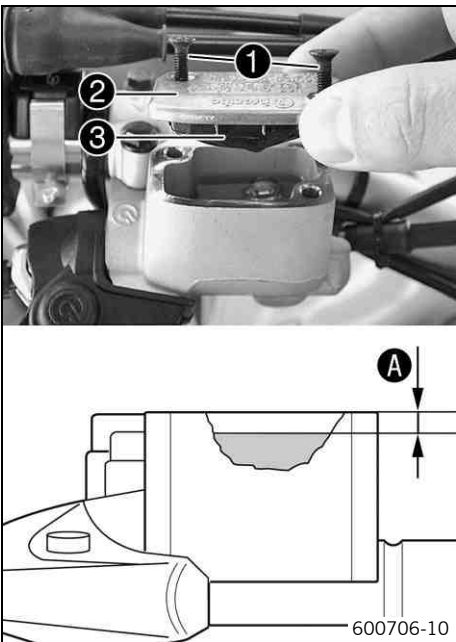

- Move the brake fluid reservoir mounted on the handlebar to a horizontal position.
- Remove screws ❶.
- Remove cover ❷ with membrane ❸.
- Add brake fluid to level A.

Guideline

Dimension A (brake fluid level below top edge of container)	5 mm (0.2 in)
---	---------------

Brake fluid DOT 4 / DOT 5.1 (☞ p. 125)

- Position the cover with the membrane. Mount and tighten the screws.

- Info**
 Clean up overflowed or spilt brake fluid immediately with water.

Checking the front brake linings

- Warning**
Danger of accidents Reduced braking efficiency caused by worn brake linings.
- Change worn brake linings immediately. (Your authorized KTM workshop will be glad to help.)

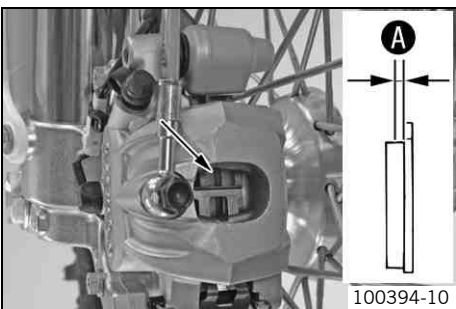

- Check the brake linings for minimum thickness A.

Minimum thickness A	≥ 1 mm (≥ 0.04 in)
---------------------	--------------------

- » If the minimum thickness is less than specified:
 - Change the front brake linings. ☞ (☞ p. 72)
- Check the brake linings for damage and cracking.
 - » If damage or cracking is visible:
 - Change the front brake linings. ☞ (☞ p. 72)

Changing the front brake linings

- Warning**
Danger of accident Brake system failure.
- Maintenance work and repairs must be carried out professionally. (Your authorized KTM workshop will be glad to help.)
- Warning**
Skin irritation Brake fluid can cause skin irritation on contact.
- Avoid contact with skin and eyes, and keep out of the reach of children.
 - Wear suitable protective clothing and goggles.
 - If brake fluid comes into contact with the eyes, flush the eyes thoroughly with water and consult a physician immediately.
- Warning**
Danger of accidents Reduced braking effect caused by old brake fluid.
- Change the brake fluid of the front and rear brake according to the service schedule. (Your authorized KTM workshop will be glad to help.)
- Warning**
Danger of accidents Reduced braking efficiency due to oil or grease on the brake discs.
- Always keep the brake discs free of oil and grease, and clean them with brake cleaner when necessary.
- Warning**
Danger of accidents Reduced braking efficiency due to use of non-approved brake linings.
- Brake linings available from accessory suppliers are often not tested and approved for use on KTM vehicles. The construction and friction factor of the brake linings and therefore the brake power can differ considerably from the original KTM brake linings. If brake linings are used that differ from the originals, there is no guarantee that they comply with the original license. The vehicle no longer corresponds to the condition at delivery, and the warranty is no longer valid.
-  **Warning**
Environmental hazard Hazardous substances cause environmental damage.
- Oil, grease, filters, fuel, cleaners, brake fluid, etc., should be disposed of as stipulated in applicable regulations.

- i** **Info**
Never use DOT 5 brake fluid! It is silicone-based and purple in color. Oil seals and brake lines are not designed for DOT 5 brake fluid.
Avoid contact between brake fluid and painted parts. Brake fluid attacks paint!
Use only clean brake fluid from a sealed container!

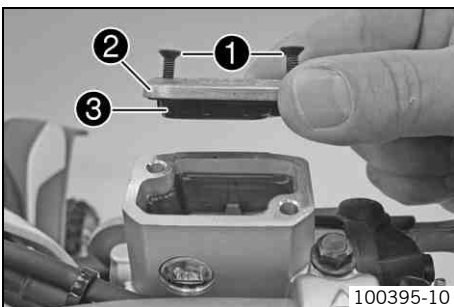

- Move the brake fluid reservoir mounted on the handlebar to a horizontal position.
- Remove screws **1**.
- Remove cover **2** with membrane **3**.
- Press the brake caliper onto the brake disc by hand in order to push back the brake pistons. Ensure that brake fluid does not overflow from the brake fluid reservoir, using suction to remove it if it does.

- i** **Info**
Make sure when pushing back the brake pistons that you do not press the brake caliper against the spokes.

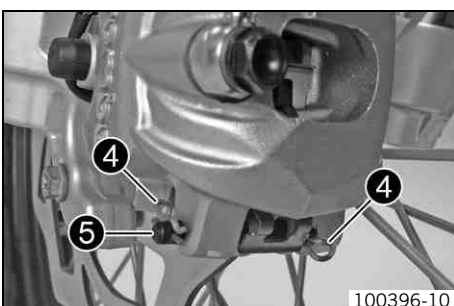

- Remove locking split pins **4**, withdraw bolt **5**, and take out the brake linings.
- Clean the brake caliper and brake caliper support.

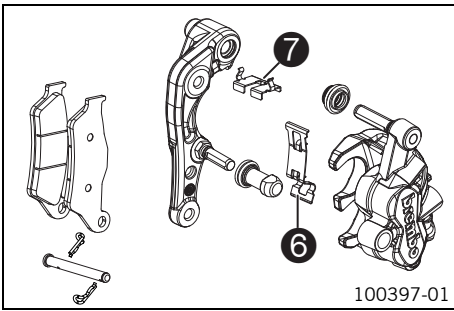

- Check that leaf spring 6 in the brake caliper and sliding plate 7 in the brake caliper support are seated correctly.

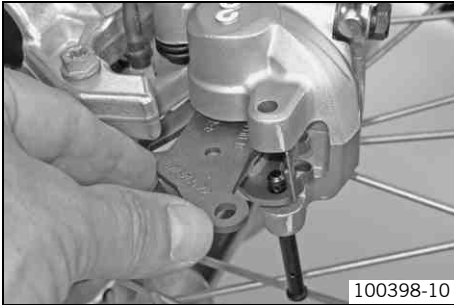

- Fit the brake linings, insert the bolt, and mount the locking split pins.
- Operate the hand brake lever several times until the brake linings are lying correctly against on the brake disc and there is a pressure point.

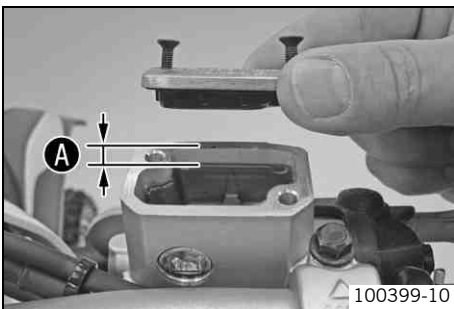

- Correct the brake fluid quantity to level A.

Guideline

Dimension A (brake fluid level below top edge of container)	5 mm (0.2 in)
---	---------------

Brake fluid DOT 4 / DOT 5.1 (☞ p. 125)
--

- Position the cover with the membrane. Mount and tighten the screws.

Info
Clean up overflowed or spilt brake fluid immediately with water.

Checking free travel of foot brake lever

Warning
Danger of accidents Brake system failure.

- If there is no free travel on the foot brake lever, pressure builds up on the rear brake circuit. The rear brake can fail due to overheating. Adjust free travel on foot brake lever according to specifications.

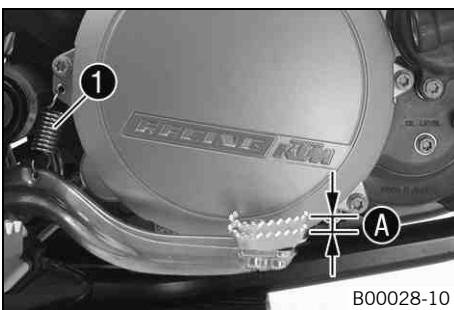

- Disconnect spring 1.
- Move the foot brake lever backwards and forwards between the end stop and the foot brake cylinder piston bracket and check free travel A.

Guideline

Free travel at foot brake lever	3... 5 mm (0.12... 0.2 in)
---------------------------------	----------------------------

- » If the free travel does not meet specifications:
 - Adjust the basic position of the foot brake lever. ☞ (☞ p. 73)
- Reconnect spring 1.

Adjusting basic position of foot brake lever ☞

Warning
Danger of accidents Brake system failure.

- If there is no free travel on the foot brake lever, pressure builds up on the rear brake circuit. The rear brake can fail due to overheating. Adjust free travel on foot brake lever according to specifications.

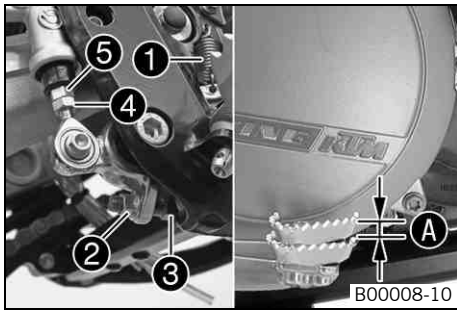

- Disconnect spring ❶.
- Loosen nut ❷ and, with push rod ❸, turn it back until you have maximum free travel.
- To adjust the basic position of the foot brake lever individually, loosen nut ❸ and turn screw ❹ accordingly.

i Info
The range of adjustment is limited.

- Turn push rod ❸ accordingly until you have free travel A. If necessary, adjust the basic position of the foot brake lever.

Guideline

Free travel at foot brake lever	3... 5 mm (0.12... 0.2 in)
---------------------------------	----------------------------

- Hold screw ❹ and tighten nut ❷.

Guideline

Nut, foot brake lever stop	M8	20 Nm (14.8 lbf ft)
----------------------------	----	------------------------

- Hold push rod ❸ and tighten nut ❷.

Guideline

Remaining nuts, chassis	M6	15 Nm (11.1 lbf ft)
-------------------------	----	------------------------

- Reconnect spring ❶.

Checking the rear brake fluid level

Warning
Danger of accidents Failure of the brake system.

- If the brake fluid level falls below the **MIN** mark, this indicates a leakage in the brake system or worn-out brake linings. Check the brake system and do not continue riding. (Your authorized KTM workshop will be glad to help.)

Warning
Danger of accidents Reduced braking effect caused by old brake fluid.

- Change the brake fluid of the front and rear brake according to the service schedule. (Your authorized KTM workshop will be glad to help.)

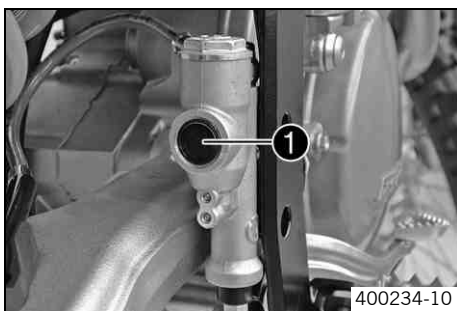

- Stand the vehicle upright.
- Check the brake fluid level in the viewer ❶.
 - » If an air bubble is visible in viewer ❶:
 - Add brake fluid for the rear brake. (p. 74)

Adding brake fluid for the rear brake

Warning
Danger of accidents Failure of the brake system.

- If the brake fluid level falls below the **MIN** mark, this indicates a leakage in the brake system or worn-out brake linings. Check the brake system and do not continue riding. (Your authorized KTM workshop will be glad to help.)

Warning
Skin irritation Brake fluid can cause skin irritation on contact.

- Avoid contact with skin and eyes, and keep out of the reach of children.
- Wear suitable protective clothing and goggles.
- If brake fluid comes into contact with the eyes, flush the eyes thoroughly with water and consult a physician immediately.

- Warning**
Danger of accidents Reduced braking effect caused by old brake fluid.
- Change the brake fluid of the front and rear brake according to the service schedule. (Your authorized KTM workshop will be glad to help.)

- Warning**
Environmental hazard Hazardous substances cause environmental damage.
- Oil, grease, filters, fuel, cleaners, brake fluid, etc., should be disposed of as stipulated in applicable regulations.

i Info
 Never use DOT 5 brake fluid! It is silicone-based and purple in color. Oil seals and brake lines are not designed for DOT 5 brake fluid.
 Avoid contact between brake fluid and painted parts. Brake fluid attacks paint!
 Use only clean brake fluid from a sealed container!

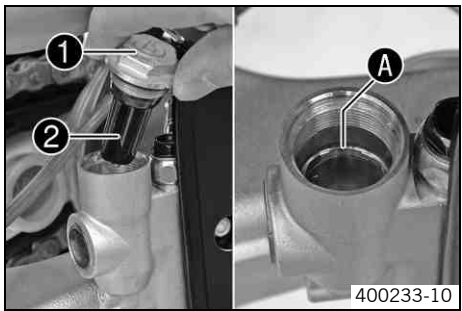

- Stand the vehicle upright.
 - Remove screw cap ① with membrane ② and the O-ring.
 - Add brake fluid to level A.
- | |
|--|
| Brake fluid DOT 4 / DOT 5.1 (☞ p. 125) |
|--|
- Mount the screw cap with the membrane and the O-ring.

i Info
 Clean up overflowed or spilt brake fluid immediately with water.

Checking the rear brake linings

- Warning**
Danger of accidents Reduced braking efficiency caused by worn brake linings.
- Change worn brake linings immediately. (Your authorized KTM workshop will be glad to help.)

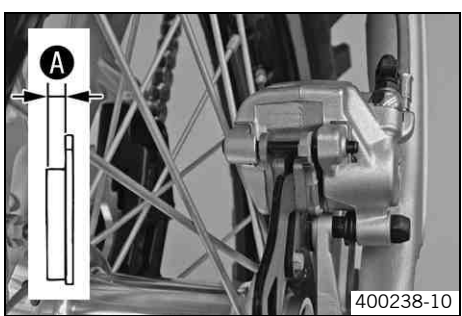

- Check the brake linings for minimum thickness A.
- | | |
|---------------------|--------------------|
| Minimum thickness A | ≥ 1 mm (≥ 0.04 in) |
|---------------------|--------------------|
- » If the minimum thickness is less than specified:
 - Change the rear brake linings. ☞ (☞ p. 76)
 - Check the brake linings for damage and cracking.
 - » If damage or cracking is visible:
 - Change the rear brake linings. ☞ (☞ p. 76)

Removing the rear brake linings ☞

- Warning**
Danger of accident Brake system failure.
- Maintenance work and repairs must be carried out professionally. (Your authorized KTM workshop will be glad to help.)

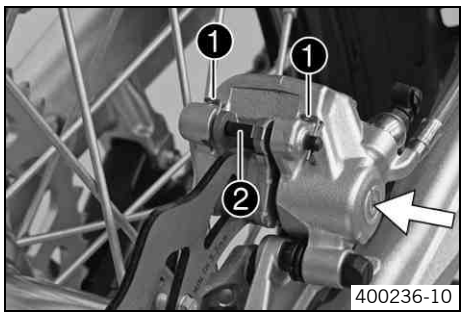

- Press the brake caliper onto the brake disc by hand in order to push back the brake piston.
- i Info**
 Make sure when pushing back the brake piston that you do not press the brake caliper against the spokes.
- Remove locking split pins ①, withdraw bolt ②, and take out the brake linings.
 - Clean the brake caliper and brake caliper support.

Installing the rear brake linings



Warning

Danger of accidents Reduced braking efficiency due to oil or grease on the brake discs.

- Always keep the brake discs free of oil and grease, and clean them with brake cleaner when necessary.



Warning

Danger of accidents Reduced braking efficiency due to use of non-approved brake linings.

- Brake linings available from accessory suppliers are often not tested and approved for use on KTM vehicles. The construction and friction factor of the brake linings and therefore the brake power can differ considerably from the original KTM brake linings. If brake linings are used that differ from the originals, there is no guarantee that they comply with the original license. The vehicle no longer corresponds to the condition at delivery, and the warranty is no longer valid.

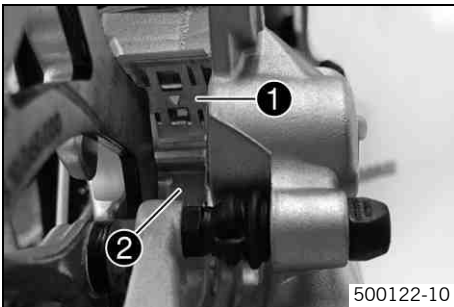

500122-10

- Check the brake discs. ( p. 70)
- Check that leaf spring **1** in the brake caliper and sliding plate **2** in the brake caliper support are seated correctly.



Info

The arrow on the leaf spring points in the rotation direction of the brake disc.

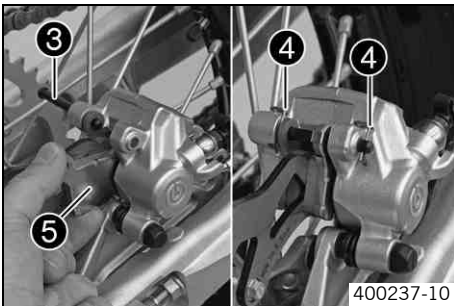

400237-10

- Insert the brake linings, insert bolt **3**, and mount locking split pins **4**.



Info

Make sure that the decoupling plate **5** is mounted on the piston side of the brake lining.

- Operate the foot brake lever several times until the brake linings are lying correctly against the brake disc and there is a pressure point.

Changing the rear brake linings



Warning

Skin irritation Brake fluid can cause skin irritation on contact.

- Avoid contact with skin and eyes, and keep out of the reach of children.
- Wear suitable protective clothing and goggles.
- If brake fluid comes into contact with the eyes, flush the eyes thoroughly with water and consult a physician immediately.



Warning

Danger of accidents Reduced braking effect caused by old brake fluid.

- Change the brake fluid of the front and rear brake according to the service schedule. (Your authorized KTM workshop will be glad to help.)



Warning

Environmental hazard Hazardous substances cause environmental damage.

- Oil, grease, filters, fuel, cleaners, brake fluid, etc., should be disposed of as stipulated in applicable regulations.



Info

Never use DOT 5 brake fluid! It is silicone-based and purple in color. Oil seals and brake lines are not designed for DOT 5 brake fluid.

Avoid contact between brake fluid and painted parts. Brake fluid attacks paint!

Use only clean brake fluid from a sealed container!

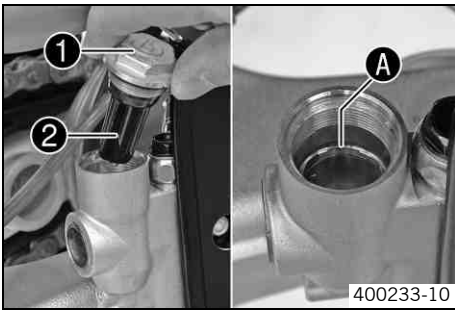

- Remove the rear brake linings. 🛠️ (📖 p. 75)
- Stand the vehicle upright.
- Remove screw cap ❶ with membrane ❷ and the O-ring.
- Press the brake piston back to its basic position and make sure that no brake fluid overflows from the brake fluid reservoir.
- Install the rear brake linings. 🛠️ (📖 p. 76)
- Add brake fluid to level A.

Brake fluid DOT 4 / DOT 5.1 (📖 p. 125)

- Mount the screw cap with the membrane and the O-ring.

**Info**

Clean up overflowed or spilt brake fluid immediately with water.

Removing the front wheel

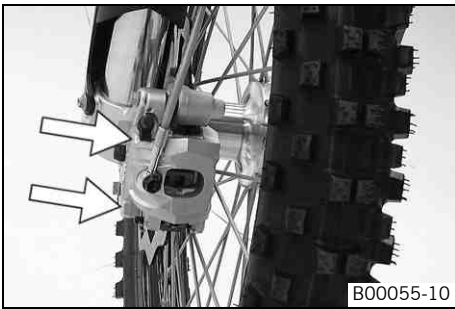

- Raise the motorcycle with the lift stand. (☛ p. 45)
- Press the brake caliper onto the brake disc by hand in order to push back the brake pistons.

i **Info**

Make sure when pushing back the brake pistons that you do not press the brake caliper against the spokes.

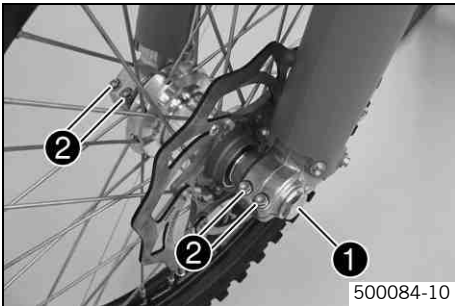

- Remove screw ❶.
- Loosen screws ❷.



- Holding the front wheel, withdraw the wheel spindle. Take the front wheel out of the fork.

i **Info**

Do not pull the hand brake lever when the front wheel is removed. Always lay the wheel down in such a way that the brake disc is not damaged.

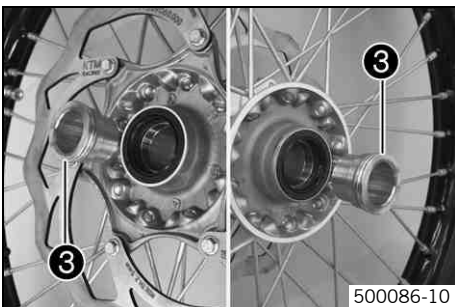

- Remove spacers ❸.

Installing the front wheel



Warning

Danger of accidents Reduced braking efficiency due to oil or grease on the brake discs.

- Always keep the brake discs free of oil and grease, and clean them with brake cleaner when necessary.

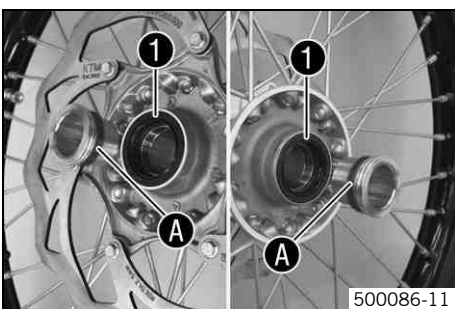

- Check the wheel bearing for damage and wear.
 - » If the wheel bearing is damaged or worn:
 - Change the wheel bearing. ☛
- Clean and grease shaft seal rings ❶ and bearing surface A of the spacers.

Long-life grease (☛ p. 127)

- Insert the spacers.

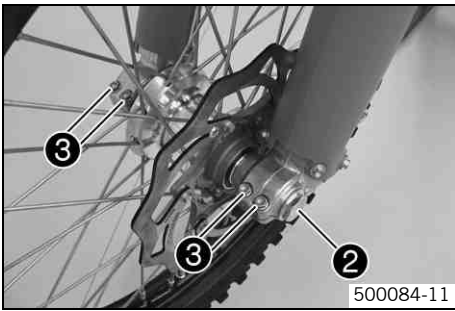

- Lift the front wheel into the fork, position it, and insert the wheel spindle.
- Mount and tighten screw ②.

Guideline

Screw, front wheel spindle	M24x1.5	45 Nm (33.2 lbf ft)
----------------------------	---------	------------------------

- Operate the hand brake lever several times until the brake linings are lying correctly against on the brake disc.
- Remove the motorcycle from the lift stand. (☛ p. 45)
- Pull the front wheel brake and push down hard on the fork several times to align the fork legs.
- Tighten screws ③.

Guideline

Screw, fork stub	M8	15 Nm (11.1 lbf ft)
------------------	----	------------------------

Removing the rear wheel ☛

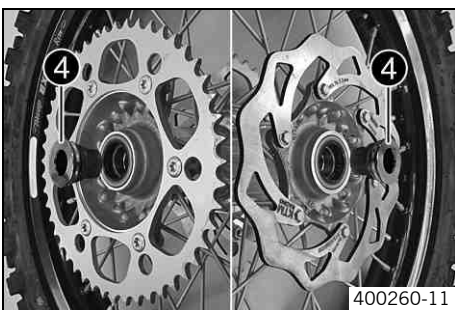
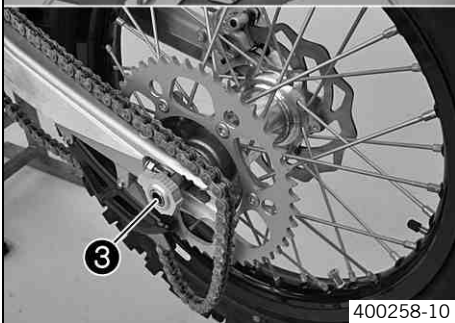
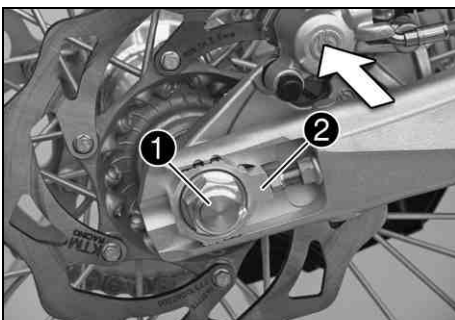

- Raise the motorcycle with the lift stand. (☛ p. 45)
- Press the brake caliper onto the brake disc by hand in order to push back the brake piston.

i Info

Make sure when pushing back the brake piston that you do not press the brake caliper against the spokes.

- Remove nut ①.
- Remove chain adjuster ②. Withdraw wheel spindle ③ only enough to allow the rear wheel to be pushed forward.
- Push the rear wheel forward as far as possible. Remove the chain from the rear sprocket.
- Holding the rear wheel, withdraw the wheel spindle. Take the rear wheel out of the swingarm.

i Info

Do not operate the foot brake when the rear wheel is removed. Always lay the wheel down in such a way that the brake disc is not damaged.

- Remove spacers ④.

Installing the rear wheel ☛

Warning

Danger of accidents Reduced braking efficiency due to oil or grease on the brake discs.

- Always keep the brake discs free of oil and grease, and clean them with brake cleaner when necessary.

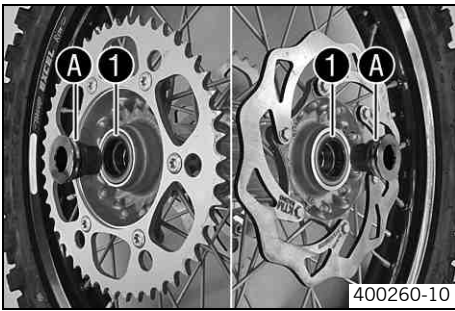

400260-10

- Check the wheel bearing for damage and wear.
 - » If the wheel bearing is damaged or worn:
 - Change the wheel bearing. 🛠️
- Clean and grease shaft seal rings **1** and bearing surface **A** of the spacers.

Long-life grease (🔧 p. 127)

- Insert the spacers.

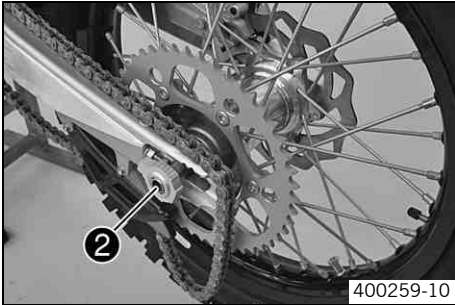

400259-10

- Lift the rear wheel into the swing arm, position it, and insert wheel spindle **2**.
- Apply the chain.

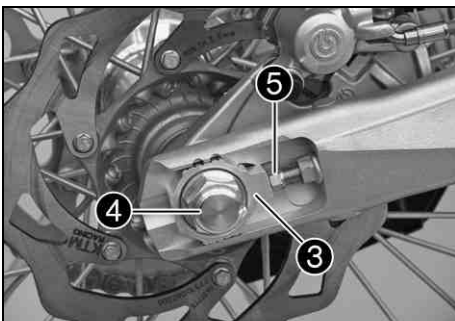

400225-12

- Position chain adjuster **3**. Mount nut **4**, but do not tighten it yet.
- Make sure that chain adjusters **3** are fitted correctly on adjusting screws **5**.
- Check the chain tension. (🔧 p. 62)
- Tighten nut **4**.

Guideline

Nut, rear wheel spindle	M20x1.5	80 Nm (59 lbf ft)
-------------------------	---------	-------------------



Info

The wide adjustment range of the chain adjusters (32 mm (1.18 in)) enables different secondary ratios with the same chain length. Chain adjusters **3** can be turned by 180°.

- Operate the foot brake lever several times until the brake linings are lying correctly against the brake disc and there is a pressure point.
- Remove the motorcycle from the lift stand. (🔧 p. 45)

Checking the tire condition

i Info
 Only mount tires approved and/or recommended by KTM.
 Other tires could have a negative effect on handling characteristics.
 The type, condition and air pressure of the tires all have an important impact on the handling characteristics of the motorcycle.
 The front and rear wheels must be mounted with tires with similar profiles.
 Worn tires have a negative effect on handling characteristics, especially on wet surfaces.

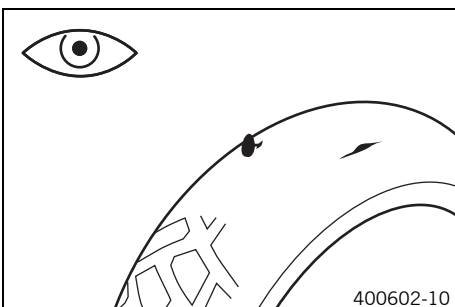

400602-10

- Check the front and rear tires for cuts, run-in objects and other damage.
 - » If the tire exhibits cuts, run-in objects or other damage:
 - Change the tire.
- Check the depth of the tread.



Info

Note local national regulations concerning the minimum tread depth.

Minimum tread depth	≥ 2 mm (≥ 0.08 in)
---------------------	--------------------

- » If the tread depth is less than the minimum permissible depth:

- Change the tire.
- Check the tire age.



Info

The tire's date of manufacture is usually part of the tire markings and is indicated by the last four digits of the **DOT** marking. The first two digits indicate the week of manufacture and the last two digits the year of manufacture.

KTM recommends that the tires are changed at the latest after 5 years, regardless of the actual state of wear.

- » If the tire is older than five years:
 - Change the tire.

Checking the tire air pressure



Info

Low tire air pressure leads to abnormal wear and overheating of the tire. Correct tire air pressure ensures optimal riding comfort and maximum tire service life.

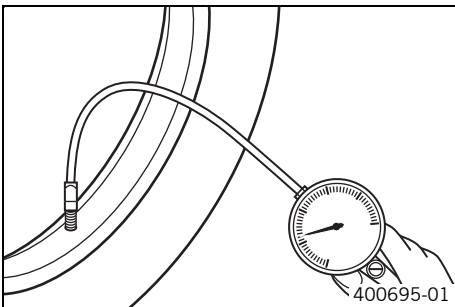

- Remove the dust cap.
- Check the tire air pressure when the tires are cold.

Tire air pressure off road	
Front	1.0 bar (15 psi)
Rear	1.0 bar (15 psi)

Tire air pressure, road (EXC, EXC Factory Edition, EXC SIX DAYS)	
Front	1.5 bar (22 psi)
Rear	2.0 bar (29 psi)

- » If the tire pressure does not meet specifications:
 - Correct the tire pressure.
- Mount the dust cap.

Checking the spoke tension



Warning

Danger of accidents Instable handling due to incorrect spoke tension.

- Ensure that the spoke tension is correct. (Your authorized KTM workshop will be glad to help.)



Info

A loose spoke causes wheel imbalance and rapidly leads to more loose spokes. If the spokes are too tight, they can break due to local overload. Check the spoke tension regularly, especially on a new motorcycle.

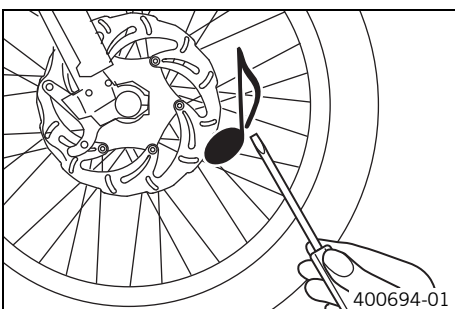

- Briefly strike each spoke with the tip of a screwdriver.



Info

The tone frequency depends on the length of the spoke and the spoke diameter.

If you hear different tone frequencies from different spokes of equal length and diameter, this is an indication of different spoke tensions.

You should hear a high note.

- » If the spoke tension varies:
 - Correct the spoke tension. 🛠️
- Check the spoke torque.

Guideline

Spoke nipple, front wheel	M4.5	5... 6 Nm (3.7... 4.4 lbf ft)
Spoke nipple, rear wheel	M5	5... 6 Nm (3.7... 4.4 lbf ft)

Torque wrench with various accessories in set (58429094000)

Removing the battery ↘ (All 250/300 models)

- Warning**
Risk of injury Battery acid and battery gases cause serious cauterization.
- Keep batteries out of the reach of children.
 - Wear suitable protective clothing and goggles.
 - Avoid contact with battery acid and battery gases.
 - Keep the battery away from sparks or open fire. Charge only in well ventilated rooms.
 - Flush with copious amounts of water in case of skin contact. If battery acid comes into contact with the eyes, flush the eyes with water for at least 15 minutes and consult a physician.

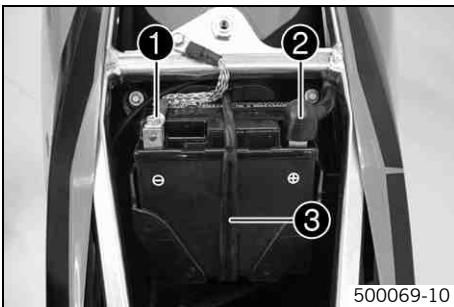

- Switch off all power consumers and switch off the engine.
- Remove the seat. (↖ p. 56)
- Disconnect the negative (minus) cable **1** of the battery.
- Pull back the plus pole cover **2** and disconnect the positive (plus) cable of the battery.
- Hang the rubber band **3** out to the bottom.
- Lift the battery up.

Installing the battery ↘ (All 250/300 models)

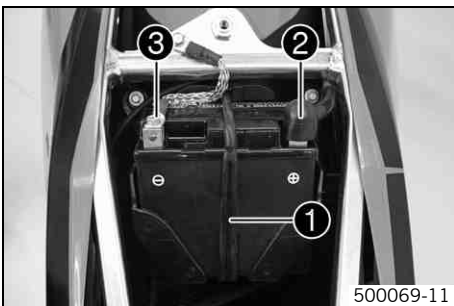

- Place the battery in the battery holder.
- Battery (YTX4L-BS) (↖ p. 118)
- Reconnect the rubber band **1**.
 - Attach the plus cable and replace the plus pole cover **2**.
 - Attach the minus cable **3**.
 - Mount the seat. (↖ p. 56)

Recharging the battery ↘ (All 250/300 models)

- Warning**
Risk of injury Battery acid and battery gases cause serious cauterization.
- Keep batteries out of the reach of children.
 - Wear suitable protective clothing and goggles.
 - Avoid contact with battery acid and battery gases.
 - Keep the battery away from sparks or open fire. Charge only in well ventilated rooms.
 - Flush with copious amounts of water in case of skin contact. If battery acid comes into contact with the eyes, flush the eyes with water for at least 15 minutes and consult a physician.

- Warning**
Environmental hazard Battery parts and acid are harmful to the environment.
- Do not discard batteries with the household trash. Dispose of a defective battery in an environmentally compatible manner. Give the battery to your KTM dealer or to a recycling center that accepts used batteries.

- Warning**
Environmental hazard Hazardous substances cause environmental damage.
- Oil, grease, filters, fuel, cleaners, brake fluid, etc., should be disposed of as stipulated in applicable regulations.

i **Info**

Even when there is no load on the battery, it still loses power steadily. The charge state and the type of charge are very important for the service life of the battery. Rapid recharging with a high charging current shortens the battery's service life. If the charging current, charging voltage and charging time are exceeded, electrolyte escapes through the safety valves. This reduces the battery capacity. If the battery is depleted from starting the vehicle repeatedly, the battery must be charged immediately. If the battery is left in a discharged state for an extended period, it will become over-discharged and sulfate, destroying the battery. The battery is maintenance-free, i.e., the acid level does not have to be checked.



- Switch off all power consumers and switch off the engine.
- Remove the seat. (☛ p. 56)
- Disconnect the minus (negative) cable of the battery to avoid damage to the motorcycle's electronics.
- Connect the battery charger to the battery. Switch on the battery charger.

Battery charger (58429074000)

You can also use the battery charger to test rest potential and start potential of the battery, and to test the alternator. With this device, you cannot overcharge the battery.

i **Info**

Never remove the lid ❶. Charge the battery with at most 10% of the capacity specified on the battery ❷.

- Switch off the charger after charging. Disconnect the battery.

Guideline

The charge current, charge voltage and charge time must not be exceeded.	
Charge the battery regularly when the motorcycle is not in use	3 months

- Mount the seat. (☛ p. 56)

Removing the main fuse (All 250/300 models)

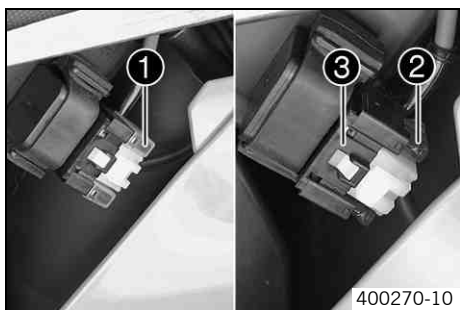

- Switch off all power consumers and switch off the engine.
- Remove the air filter box lid. (☛ p. 57)
- Remove the protection cover ❶.

i **Info**

The main fuse ❷ is located in the starter relay ❸ under the filter box cover.

- Remove main fuse ❷.

Installing the main fuse (All 250/300 models)

⚠ Warning

Fire hazard The electrical system can be overloaded by the use of incorrect fuses.

- Use only fuses with the prescribed amperage. Never by-pass or repair fuses.

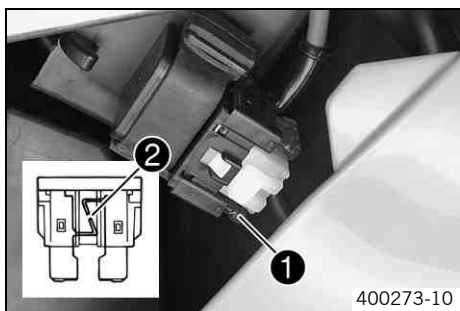

- Insert the main fuse.

Fuse (58011109110)



Info

A reserve fuse ❶ is located in the starter relay.
Replace a burned-out fuse ❷ only by an equivalent fuse.

- Replace the protection cover.
- Install the air filter box lid. (☛ p. 57)

Removing the headlight mask with the headlight (EXC, EXC Factory Edition, EXC SIX DAYS)

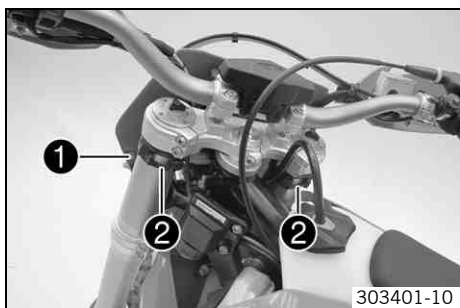

- Switch off all power consumers.
- Remove screw ❶ and take off the clamp.
- Release rubber band ❷. Slide the headlight mask up and swing it forward.

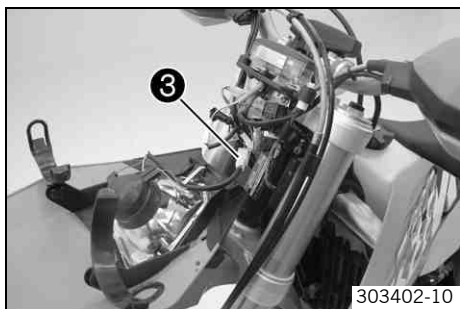

- Disconnect the electrical plug-in connection ❸ and take off the headlight mask with the headlight.

Refitting the headlight mask with the headlight (EXC, EXC Factory Edition, EXC SIX DAYS)

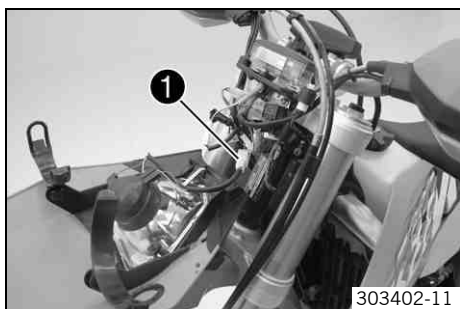

- Connect the electric plug connector ❶.

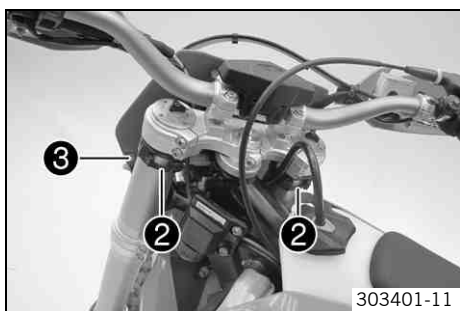

- Position the headlight mask and fix it with the rubber band ❷.



Info

Ensure that the holding lugs engage in the fender.

- Position the brake line and wiring harness. Put on the clamp and mount and tighten screw ❸.
- Check the headlight setting. (☛ p. 86)

Changing the headlight bulb (EXC, EXC Factory Edition, EXC SIX DAYS)

Note

Damage to reflector Reduced luminance.

- Grease on the lamp will evaporate due to the heat and be deposited on the reflector. Clean the lamp and keep it free of grease before mounting.

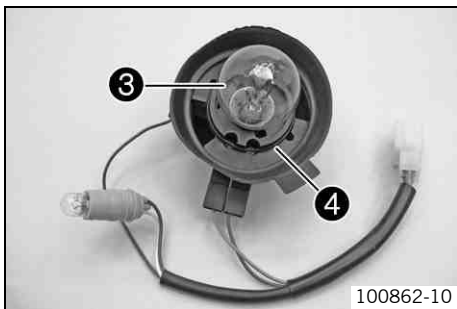
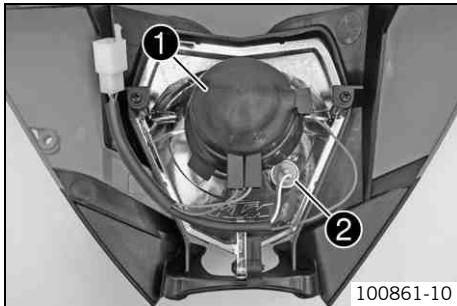

- Remove the headlight mask with the headlight. (☛ p. 85)
- Turn rubber cap ① together with the underlying lamp socket counterclockwise all the way and remove it.
- Pull lamp socket ② of the parking light out of the reflector.

- Press headlight bulb ③ lightly into the lamp socket, turn it counterclockwise and pull it out.
- Insert the new headlight bulb.

Headlight (S2 / socket BA20d) (☛ p. 119)
--

- Insert the rubber cap with the lamp socket into the reflector and turn it clockwise all the way.

Info

Ensure that the O-ring ④ is seated properly.

- Insert the lamp socket of the parking light into the reflector.
- Refit the headlight mask with the headlight. (☛ p. 85)

Checking the headlight setting (EXC, EXC Factory Edition, EXC SIX DAYS)

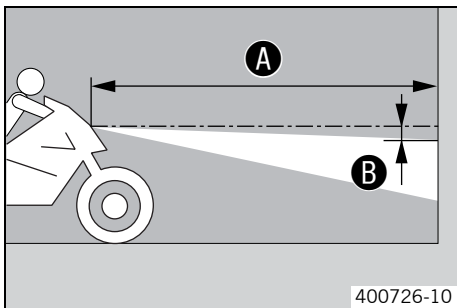

- Position the vehicle upright on a horizontal surface in front of a light wall and make a mark at the height of the center of the low beam headlight.
- Make another mark a distance ⑤ under the first mark.

Guideline

Distance ⑤	5 cm (2 in)
------------	-------------

- Position the vehicle vertically a distance ⑥ away from the wall.

Guideline

Distance ⑥	5 m (16 ft)
------------	-------------

- The rider now sits down on the motorcycle.
- Switch on the low beam.
- Check the headlight setting.

The boundary between light and dark must be exactly on the lower mark for an operational motorcycle with a rider.

- » If the boundary between light and dark does not meet specifications:
 - Adjust the headlight range. (☛ p. 87)

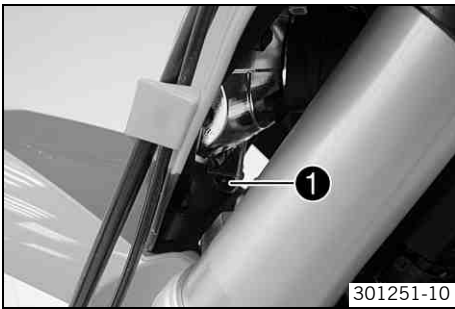
Adjusting the headlight range (EXC, EXC Factory Edition, EXC SIX DAYS)

- Check the headlight setting. (☛ p. 86)
- Loosen screw ❶.
- Adjust the headlight range by moving the headlight.

Guideline

The boundary between light and dark must be exactly on the lower mark for an operational motorcycle with a rider (to prepare the mark, see: Checking the headlight setting).

**Info**

The headlight range may need to be corrected if luggage is carried on the vehicle.

- Tighten screw ❶.

Changing the speedometer battery**(EXC, EXC Factory Edition, EXC SIX DAYS)**

- Remove the headlight mask with the headlight. (☛ p. 85)

(XC-W)

- Remove the start number plate. (☛ p. 54)
- Remove screws ❶.
- Pull the speedometer up and out of the holder.

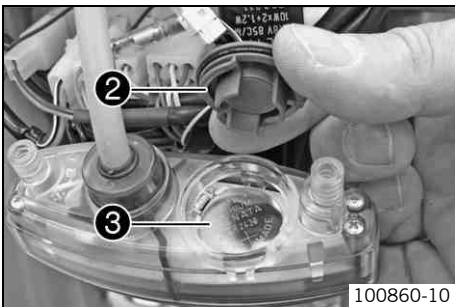
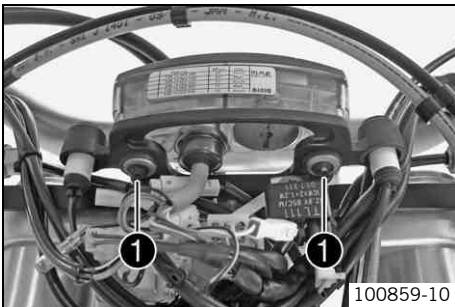

- Turn locking cap ❷ counterclockwise all the way using a coin and remove it.
- Remove speedometer battery ❸.
- Insert the new battery with the lettering facing up.

Speedometer battery (CR 2430)

- Check that the O-Ring of the locking cap is seated properly.

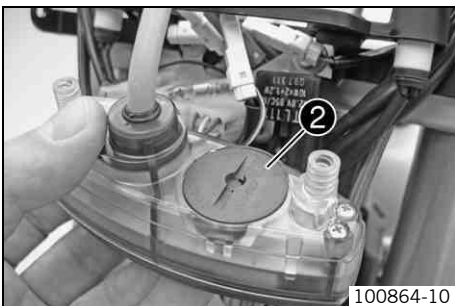

- Position locking cap ❷ and turn it clockwise all the way using a coin.
- Press any button on the speedometer.
 - ✓ The speedometer is activated.
- Position the speedometer in the holder.
- Mount and tighten the screws with the washers.

(EXC, EXC Factory Edition, EXC SIX DAYS)

- Refit the headlight mask with the headlight. (☛ p. 85)

(XC-W)

- Install the start number plate. (☛ p. 54)
- Set kilometers or miles. (☛ p. 16)
- Adjust the speedometer functions. (☛ p. 17)
- Set the clock. (☛ p. 16)

Cooling system

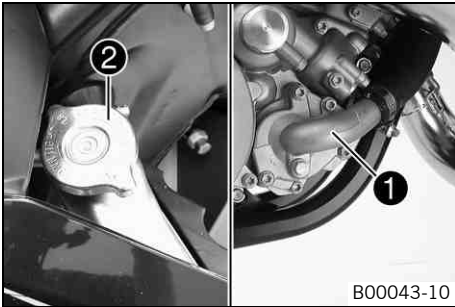

(All 125/200 models)

Water pump ❶ in the engine circulates the coolant.

The pressure resulting from the warming of the cooling system is regulated by a valve in radiator cap ❷. This ensures that operating the vehicle at the specified coolant temperature will not result in a risk of malfunctions.

120 °C (248 °F)

Cooling is effected by the air stream.

The lower the speed, the less the cooling effect. Dirty cooling fins also reduce the cooling effect.

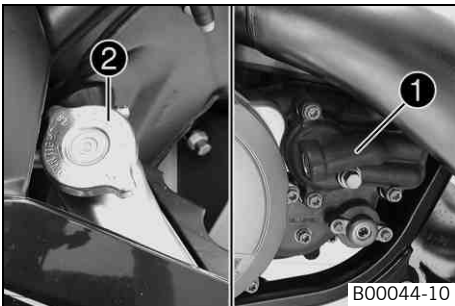

(All 250/300 models)

Water pump ❶ in the engine circulates the coolant.

The pressure resulting from the warming of the cooling system is regulated by a valve in radiator cap ❷. This ensures that operating the vehicle at the specified coolant temperature will not result in a risk of malfunctions.

120 °C (248 °F)

Cooling is effected by the air stream.

The lower the speed, the less the cooling effect. Dirty cooling fins also reduce the cooling effect.

Checking the antifreeze and coolant level

Warning

Danger of scalding During motorcycle operation, the coolant gets very hot and is under pressure.

- Do not remove the radiator cap, radiator hoses or other cooling system components when the engine is hot. Allow the engine and cooling system to cool down. In case of scalding, rinse immediately with lukewarm water.

Warning

Danger of poisoning Coolant is poisonous and a health hazard.

- Avoid contact between coolant and skin, eyes and clothing. If it gets into your eyes, rinse immediately with water and contact a doctor. Wash affected skin areas immediately with soap and water. If coolant is swallowed, contact a doctor immediately. Change clothes that have come into contact with coolants. Keep coolant out of the reach of children.

Condition

The engine is cold.

- Stand the motorcycle upright on a horizontal surface.
- Remove the radiator cap.
- Check the coolant antifreeze.

-25... -45 °C (-13... -49 °F)

» If the coolant antifreeze does not meet specifications:

- Correct the coolant antifreeze.

- Check the coolant level in the radiator.

Coolant level ❶ above the radiator fins.	10 mm (0.39 in)
--	-----------------

» If the level of the coolant does not meet specifications:

- Correct the coolant level.

Alternative 1

Coolant (☛ p. 125)

Alternative 2

Coolant (mixed ready to use) (☛ p. 125)

- Mount the radiator cap.

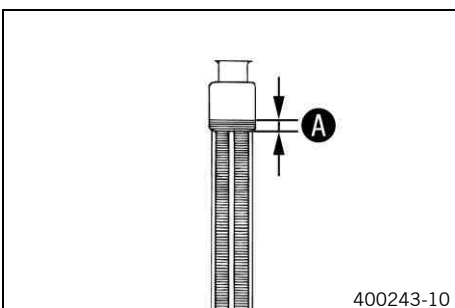

Checking the coolant level



Warning

Danger of scalding During motorcycle operation, the coolant gets very hot and is under pressure.

- Do not remove the radiator cap, radiator hoses or other cooling system components when the engine is hot. Allow the engine and cooling system to cool down. In case of scalding, rinse immediately with lukewarm water.



Warning

Danger of poisoning Coolant is poisonous and a health hazard.

- Avoid contact between coolant and skin, eyes and clothing. If it gets into your eyes, rinse immediately with water and contact a doctor. Wash affected skin areas immediately with soap and water. If coolant is swallowed, contact a doctor immediately. Change clothes that have come into contact with coolants. Keep coolant out of the reach of children.

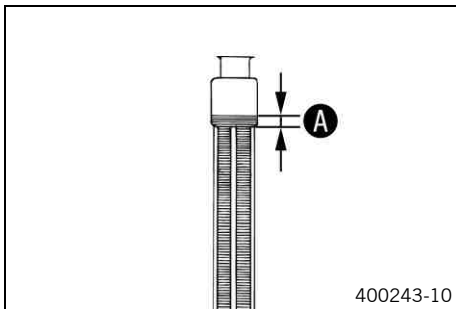

Condition

The engine is cold.

- Stand the motorcycle upright on a horizontal surface.
- Remove the radiator cap.
- Check the coolant level in the radiator.

Coolant level A above the radiator fins.	10 mm (0.39 in)
---	-----------------

» If the level of the coolant does not meet specifications:

- Correct the coolant level.

Alternative 1

Coolant (☞ p. 125)

Alternative 2

Coolant (mixed ready to use) (☞ p. 125)

- Mount the radiator cap.

Draining the coolant



Warning

Danger of scalding During motorcycle operation, the coolant gets very hot and is under pressure.

- Do not remove the radiator cap, radiator hoses or other cooling system components when the engine is hot. Allow the engine and cooling system to cool down. In case of scalding, rinse immediately with lukewarm water.



Warning

Danger of poisoning Coolant is poisonous and a health hazard.

- Avoid contact between coolant and skin, eyes and clothing. If it gets into your eyes, rinse immediately with water and contact a doctor. Wash affected skin areas immediately with soap and water. If coolant is swallowed, contact a doctor immediately. Change clothes that have come into contact with coolants. Keep coolant out of the reach of children.

Condition

The engine is cold.

- Position the motorcycle upright.
- Place a suitable container under the water pump cover.

(All 125/200 models)

- Remove screw **1**. Remove radiator cap **2**.
- Completely drain the coolant.
- Mount screw **1** with a new seal ring and tighten it.

Guideline

Drain plug, water pump cover	M10x1	15 Nm (11.1 lbf ft)
------------------------------	-------	------------------------

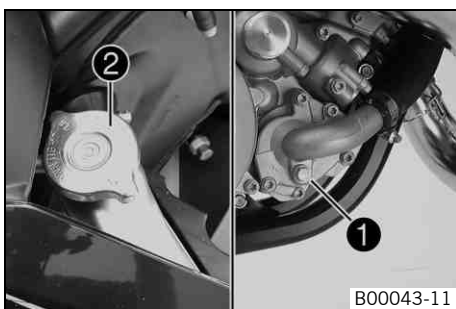

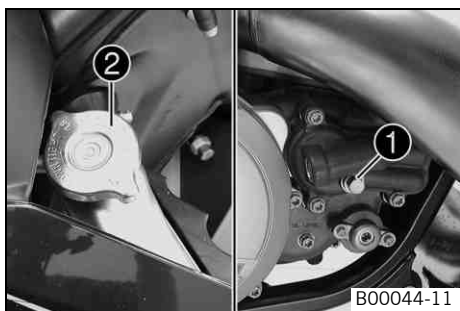

(All 250/300 models)

- Remove screw ❶. Remove radiator cap ❷.
- Completely drain the coolant.
- Mount screw ❶ with a new seal ring and tighten it.

Guideline

Drain plug, water pump cover	M10x1	15 Nm (11.1 lbf ft)
------------------------------	-------	------------------------

Refilling with coolant



Warning

Danger of poisoning Coolant is poisonous and a health hazard.

- Avoid contact between coolant and skin, eyes and clothing. If it gets into your eyes, rinse immediately with water and contact a doctor. Wash affected skin areas immediately with soap and water. If coolant is swallowed, contact a doctor immediately. Change clothes that have come into contact with coolants. Keep coolant out of the reach of children.

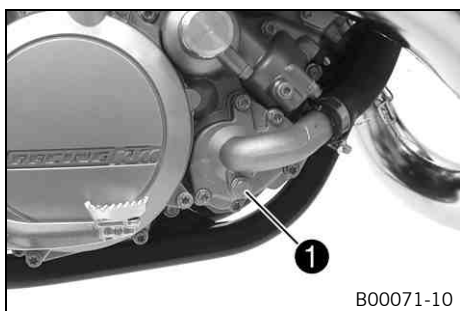

(All 125/200 models)

- Make sure that screw ❶ is tightened.
- Position the motorcycle upright.
- Fill the radiator completely with coolant.

Coolant	1.2 l (1.3 qt.)	Coolant (☛ p. 125)
		Coolant (mixed ready to use) (☛ p. 125)

- Loosen screw ❸ until coolant that does not contain any bubbles escapes. Replace and retighten screw ❸.

Guideline

Bleeder screw, cylinder head	M6	10 Nm (7.4 lbf ft)
------------------------------	----	-----------------------

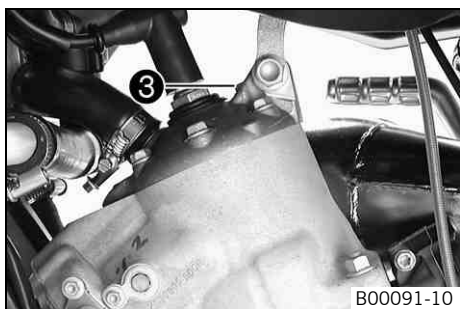

(All 250/300 models)

- Make sure that screw ❶ is tightened.
- Position the motorcycle upright.
- Fill the radiator completely with coolant.

Coolant	1.2 l (1.3 qt.)	Coolant (☛ p. 125)
		Coolant (mixed ready to use) (☛ p. 125)

- Position the vehicle as shown and secure it against rolling away. A height difference of A must be reached.

Guideline

Height difference A	75 cm (29.5 in)
---------------------	-----------------

i Info

To ensure that all of the air can escape from the cooling system, the front of the vehicle must be jacked up. A poorly bled cooling system is less effective at cooling and may result in overheating of the engine.

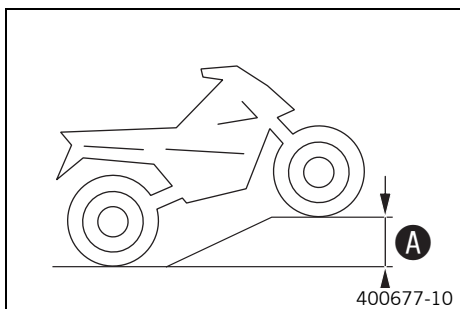

- Place the vehicle back on a level surface.



- Fill the radiator completely with coolant.
- Mount radiator cap ②.
- Run the engine until it is warm.
- Check the coolant level. (➔ p. 89)

Checking the play in the throttle cable

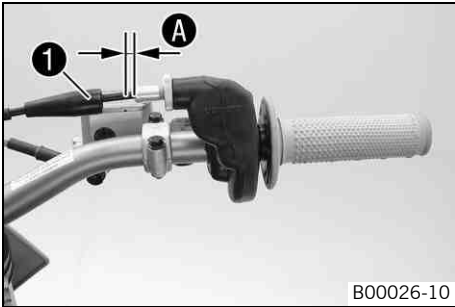

B00026-10

- Move the handlebar to the straight-ahead position.
- Push back sleeve ❶.
- Pull back the throttle cable casing until you sense a resistance.
- Now check throttle cable play ❷.

Play in throttle cable	3... 5 mm (0.12... 0.2 in)
------------------------	----------------------------

- » If the throttle cable play does not meet specifications:
 - Adjust the play in the throttle cable. 🛠️ (👉 p. 92)
- Slide on sleeve ❶. Check the throttle grip for smooth operation.

Adjusting the play in the throttle cable 🛠️

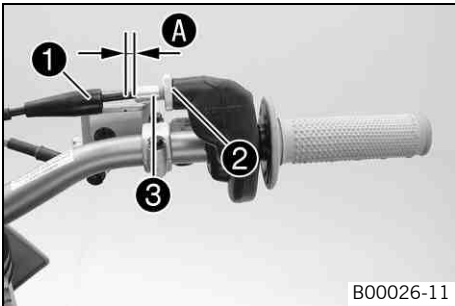

B00026-11

- Move the handlebar to the straight-ahead position.
- Push back bellows ❶.
- Loosen nut ❷. Turn adjusting screw ❸ in as far as possible.
- Turn the adjusting screw so that there is play ❷ at the outer casing of the throttle cable.

Guideline

Play in throttle cable	3... 5 mm (0.12... 0.2 in)
------------------------	----------------------------

- Tighten the nut.
- Slide on sleeve ❶. Check the throttle grip for smooth operation.

Carburetor

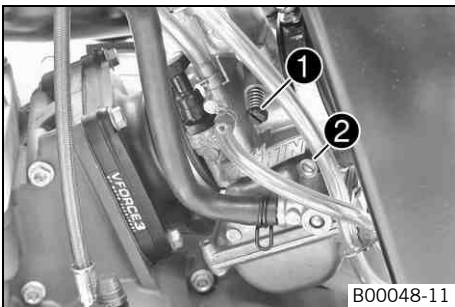

B00048-11

The idle setting of the carburetor has a big influence on the starting behavior, stable idling and the response to throttle opening. That means that an engine with a correctly set idle speed is easier to start than if the idle is set wrongly.

Info

The carburetor and its components are subject to increased wear caused by engine vibration. Wear can result in malfunctioning.

The factory setting for the carburetor is set for the following values.

Elevation above sea level	500 m (1,640 ft)
Ambient temperature	20 °C (68 °F)

Super unleaded gasoline, mixed with 2-stroke engine oil (1:60) (👉 p. 126)

The idle speed is adjusted with adjusting screw ❶.
The idle mixture is adjusted with the idle air adjusting screw ❷.

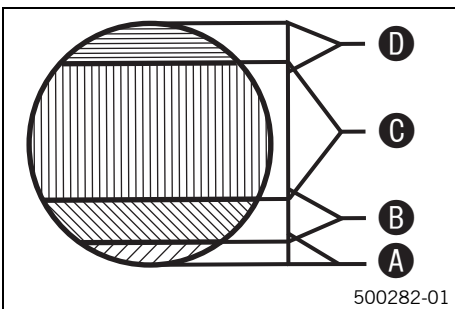

500282-01

Idle air range A

Operation with the throttle slide closed. This range is influenced by adjusting screw ❶ and the idle air adjusting screw ❷.

Transition range B

Behavior of the engine when the throttle slide is being opened. This range is influenced by the idling jet and by the form of the throttle slide.

If the engine sputters and smokes heavily when it starts despite a good idle and part-load setting, and if it abruptly reaches full power at a high rpm, the carburetor setting is too rich, or the float level is too high or the float needle valve is leaky.

Part-load range C

Operation with the throttle slide partially open. This range is influenced by the jet needle (form and position). The idle setting influences the engine tuning in the lower range, and the main jet influences the engine tuning in the upper range.

If the engine sputters when accelerating with a partially open throttle slide, the jet needle must be lowered by one notch. If the engine knocks when accelerating at the full power rpm range, the jet needle must be raised. If the above events occur on idle or just above it, the idle system must be set to a leaner setting if the engine is stuttering or to a richer setting if the engine is knocking.

Full-load range D

Operation with the throttle slide open (full throttle). This range is influenced by the main jet and jet needle.

If the insulator of a new spark plug is very light or white after a brief ride at full throttle, or if the engine knocks, a larger main jet needs to be used. If the insulator is dark brown or sooty, a smaller main jet needs to be used.

Carburetor - adjusting the idle speed 🛠️

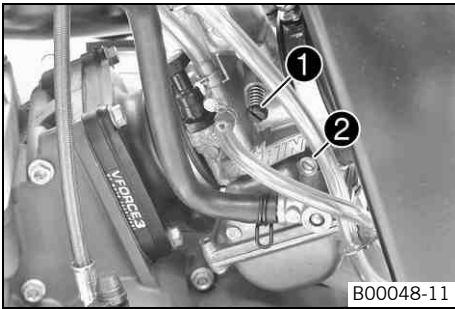

- Screw in idle air adjusting screw ② all the way and turn it to the specified basic position.

Guideline

Idle air adjusting screw (All 125 models)	
Open	2.5 turns
Idle air adjusting screw (XC-W)	
Open	2.0 turns
Idle air adjusting screw (200 EXC EU)	
Open	1.5 turns
Idle air adjusting screw (200 EXC AUS)	
Open	1.0 turn
Idle air adjusting screw (250/300 EXC AUS)	
Open	3.5 turns
Idle air adjusting screw (All 250 EXC EU models)	
Open	1.75 turns
Idle air adjusting screw (All 300 EXC EU models)	
Open	1.75 turns

- Run the engine until warm.

Guideline

Warm-up time	≥ 5 min
--------------	---------



Danger

Danger of poisoning Exhaust gases are poisonous and inhaling them may result in unconsciousness and/or death.

- When running the engine, always make sure there is sufficient ventilation, and do not start or run the engine in an enclosed space without an effective exhaust extraction system.

- Adjust the idle speed with adjusting screw ①.

Guideline

Choke function deactivated – The choke lever is pushed in all the way. (EXC AUS, XC-W) (☛ p. 23)	
Choke function deactivated – The choke lever is pushed back to the stop. (EXC EU, EXC SIX DAYS, EXC Factory Edition) (☛ p. 12)	
Idle speed	1,400... 1,500 rpm

- Turn idle air adjusting screw ② slowly in a clockwise direction until the idle speed begins to fall.
- Note the position and turn the idle air adjusting screw slowly counterclockwise until the idle speed falls again.
- Adjust to the point between these two positions with the highest idle speed.



Info

If there is a large engine speed rise, reduce the idle speed to a normal level and repeat the above steps.

If the procedure described here does not lead to satisfactory results, the cause may be a wrongly dimensioned idling jet.

If you can turn the idle air adjusting screw to the end without any change of engine speed, you need to install a smaller idling jet.

After changing the idling jet, repeat the adjusting steps from the beginning. Following extreme air temperature or altitude changes, adjust the idle speed again.

Emptying the carburetor float chamber



Danger

Fire hazard Fuel is highly flammable.

- Never refuel the vehicle near open flames or burning cigarettes, and always switch off the engine first. Be careful that no fuel is spilt, especially on hot vehicle components. Clean up spilt fuel immediately.
- Fuel in the fuel tank expands when warm and can escape if the tank is overfilled. See the notes on refueling.



Warning

Danger of poisoning Fuel is poisonous and a health hazard.

- Avoid contact between fuel and skin, eyes and clothing. Do not inhale fuel vapors. If fuel gets into your eyes, rinse immediately with water and contact a doctor. Wash affected skin areas immediately with soap and water. If fuel is swallowed, contact a doctor immediately. Change clothing that has come into contact with fuel. Store fuel in a suitable canister according to regulations and keep it out of the reach of children.



Warning

Environmental hazard Improper handling of fuel is a danger to the environment.

- Do not allow fuel to get into the ground water, the ground, or the sewage system.



Info

Carry out this work with a cold engine.
Water in the float chamber results in malfunctioning.

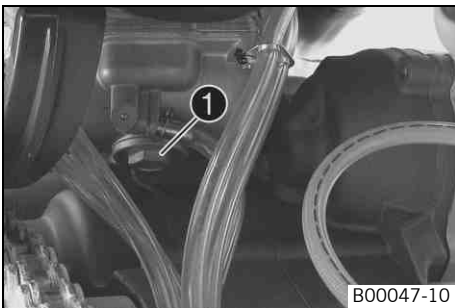

B00047-10

- Turn handle ❶ of the fuel tap to the **OFF** position.
 - ✓ No more fuel flows from the tank to the carburetor.
- Place a cloth beneath the carburetor to soak up emerging fuel.
- Remove plug ❶.
- Completely drain the fuel.
- Mount and tighten the plug.

Checking the basic position of the shift lever

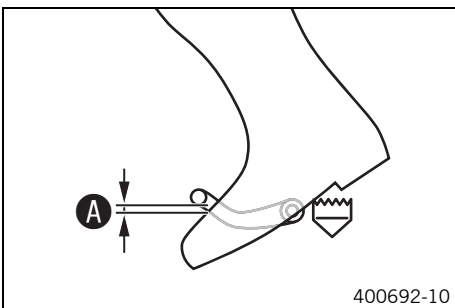

400692-10

- Sit on the vehicle in the riding position and determine the distance **A** between the upper edge of your boot and the shift lever.

Distance between shift lever and upper edge of boot	10... 20 mm (0.39... 0.79 in)
---	-------------------------------

- » If the distance does not meet specifications:
 - Adjust the basic position of the shift lever.  (p. 94)

Adjusting the basic position of the shift lever

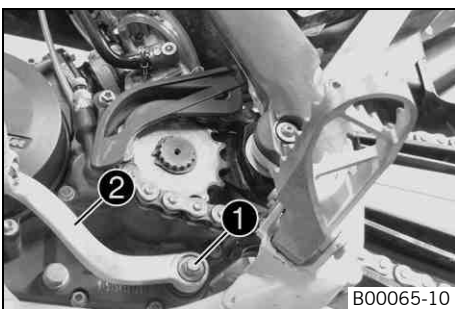

B00065-10

- Remove screw ❶ and remove shift lever ❷.

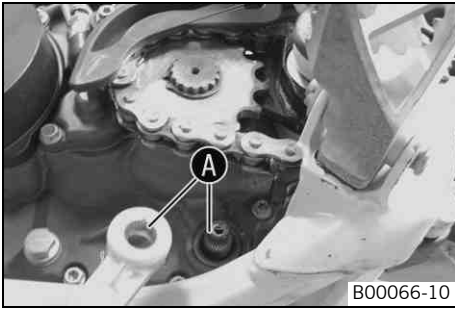

B00066-10

- Clean gear teeth **A** of the shift lever and shift shaft.
- Mount the shift lever on the shift shaft in the required position and engage the gearing.



Info

The range of adjustment is limited. The shift lever must not come into contact with any other vehicle components during the shift procedure.

- Mount and tighten the screw.

Guideline

Screw, shift lever	M6	14 Nm (10.3 lbf ft)	Loctite® 243™
--------------------	----	------------------------	---------------

Engine characteristic - auxiliary spring (All 250/300 models)

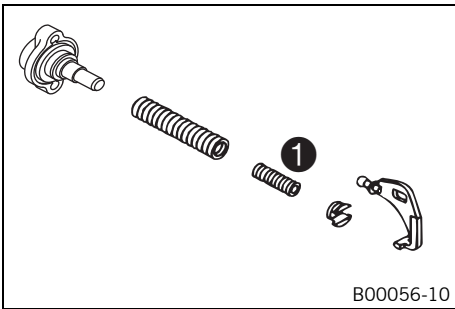

B00056-10

The auxiliary spring is located on the right side of the engine below the water pump cover.

Possible states

- Auxiliary spring with yellow marking – Auxiliary spring mounted at the factory with medium tuning (standard) for good rideability.
- Auxiliary spring with green marking – Auxiliary spring contained in the separate enclosure for softer performance.
- Auxiliary spring with red marking – Auxiliary spring contained in the separate enclosure for more aggressive performance.

The engine characteristic can be influenced by different spring strengths of the auxiliary spring **1**.

Engine characteristic - adjusting the auxiliary spring (All 250/300 models)



Warning

Danger of burns Some vehicle components become very hot when the vehicle is operated.

- Do not touch hot components such as exhaust system, radiator, engine, shock absorber and brakes. Allow these components to cool down before starting work on them.

- Tilt the motorcycle approx. 45° to the left and secure it in this position to prevent it from falling over.

- Remove screws **1**.

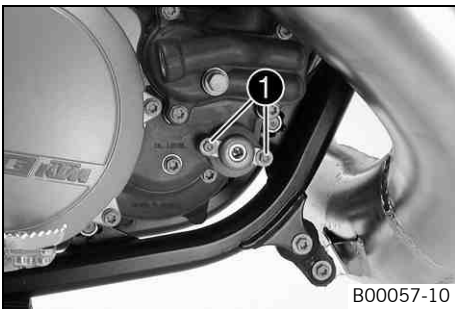

B00057-10

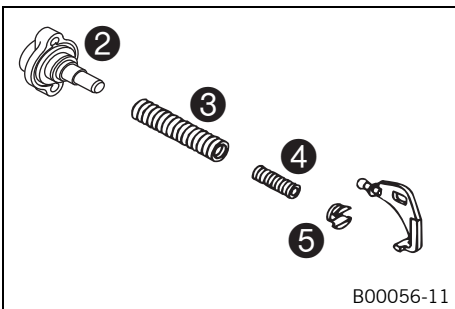

B00056-11

- Take locking cap **2**, adjusting spring **3**, auxiliary spring **4** and spring insert **5** out of the clutch cover.

- Pull both springs off of the spring insert.

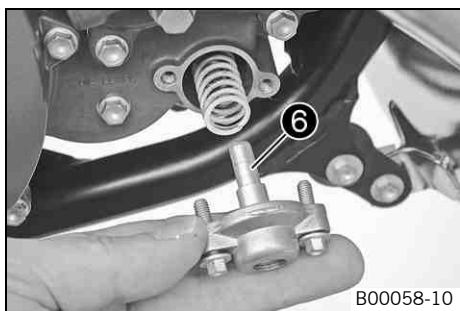

B00058-10

- Mount the desired auxiliary spring ④ and adjusting spring ③ and slide them into the clutch cover together.

Auxiliary spring with yellow marking (54637072300)
Auxiliary spring with green marking (54837072100)
Auxiliary spring with red marking (54837072000)

- ✓ The cut-out of spring insert ⑤ engages in the angle lever.



Info

Under no circumstances should screw ⑥ be turned as this would have a negative effect on the engine characteristic.

- Check the O-ring in the locking cap.
- Position the locking cap.
- Mount and tighten the screws.

Guideline

Screw, exhaust control cover	M5	5 Nm (3.7 lbf ft)
------------------------------	----	-------------------

Checking the gear oil level



Info

The gear oil level must be checked when the engine is cold.

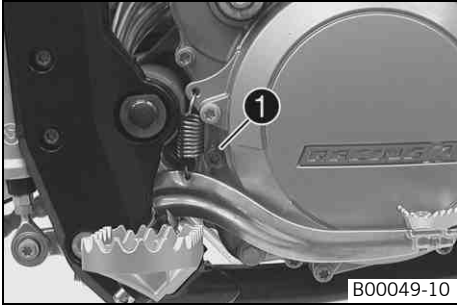

– Stand the motorcycle upright on a horizontal surface.

(All 125/200 models)

- Remove gear oil level check screw ❶.
- Check the gear oil level.

A small amount of gear oil should flow out of the hole.

- » If no gear oil flows out:
 - Add gear oil. 🛠️ (📖 p. 99)

– Mount and tighten the gear oil level check screw.

Guideline

Screw, gear oil level check	M6	10 Nm (7.4 lbf ft)
-----------------------------	----	-----------------------

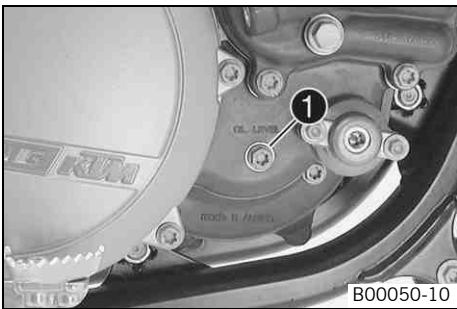

(All 250/300 models)

- Remove gear oil level check screw ❶.
- Check the gear oil level.

A small amount of gear oil should flow out of the hole.

- » If no gear oil flows out:
 - Add gear oil. 🛠️ (📖 p. 99)

– Mount and tighten the gear oil level check screw.

Guideline

Screw, gear oil level check	M6	10 Nm (7.4 lbf ft)
-----------------------------	----	-----------------------

Changing the gear oil 🛠️

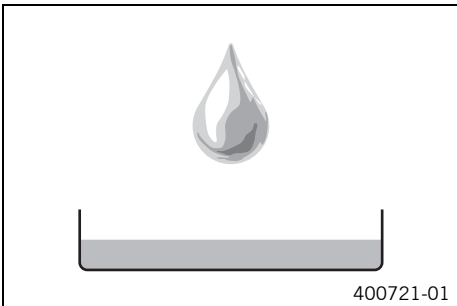

– Drain the gear oil. 🛠️ (📖 p. 98)

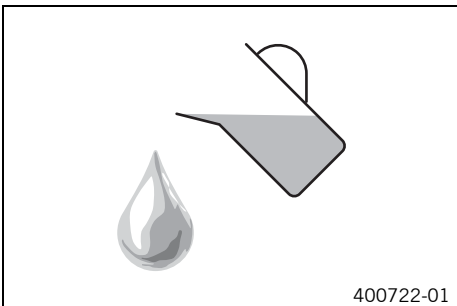

– Refill with gear oil. 🛠️ (📖 p. 98)

Draining the gear oil



Warning

Danger of scalding Engine oil and gear oil get very hot when the motorcycle is ridden.

- Wear appropriate protective clothing and safety gloves. In case of burns, rinse immediately with lukewarm water.



Warning

Environmental hazard Hazardous substances cause environmental damage.

- Oil, grease, filters, fuel, cleaners, brake fluid, etc., should be disposed of as stipulated in applicable regulations.



Info

Drain the gear oil only when the engine is warm.

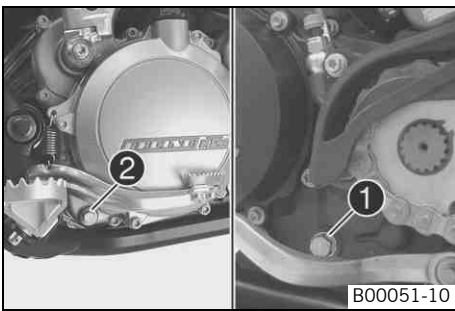

B00051-10

- Place the motorcycle on a level surface.
- Place a suitable container under the engine.

(All 125/200 models)

- Remove the gear oil drain plug with magnet ❶.
- Remove the gear oil drain plug ❷.
- Completely drain the gear oil.
- Clean the gear oil drain plug thoroughly.
- Clean the sealing area on the engine.
- Mount the gear oil drain plug with magnet ❶ and the seal ring and tighten it.

Guideline

Gear oil drain plug with magnet	M12x1.5	20 Nm (14.8 lbf ft)
---------------------------------	---------	------------------------

- Mount gear oil drain plug ❷ with the seal ring and tighten it.

Guideline

Gear oil drain plug	M10x1	15 Nm (11.1 lbf ft)
---------------------	-------	------------------------

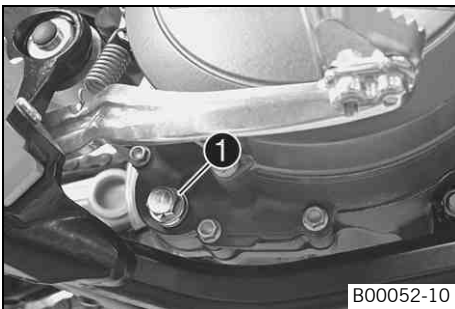

B00052-10

(All 250/300 models)

- Remove the gear oil drain plug with magnet ❶.
- Completely drain the gear oil.
- Thoroughly clean the gear oil drain plug with a magnet.
- Clean the sealing area on the engine.
- Mount the gear oil drain plug with magnet ❶ and the seal ring and tighten it.

Guideline

Gear oil drain plug with magnet	M12x1.5	20 Nm (14.8 lbf ft)
---------------------------------	---------	------------------------

Refilling with gear oil



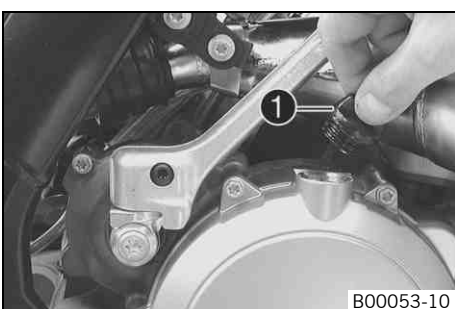

Info

Too little gear oil or poor-quality oil results in premature wear of the transmission.



B00053-10

- Remove screw cap ❶ and fill up gear oil.

Gear oil (All 125/200 models)	0.70 l (0.74 qt.)	Engine oil (15W/50) ( p. 125)
Gear oil (All 250/300 models)	0.80 l (0.85 qt.)	Engine oil (15W/50) ( p. 125)

- Mount and tighten the screw cap.



Danger

Danger of poisoning Exhaust gases are poisonous and inhaling them may result in unconsciousness and/or death.

- When running the engine, always make sure there is sufficient ventilation, and do not start or run the engine in an enclosed space without an effective exhaust extraction system.

- Start the engine and check that it is oil-tight.
- Check the gear oil level. (🔧 p. 97)

Adding gear oil 🛠️

i Info

Too little gear oil or poor-quality oil results in premature wear of the transmission. The gear oil must be added when the engine is cold.

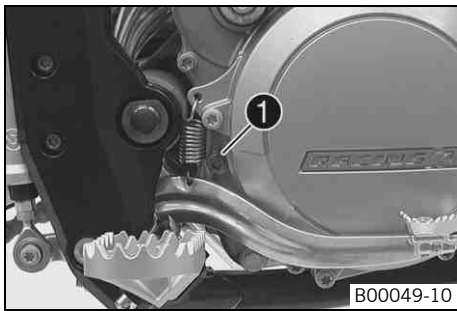

- Place the motorcycle on a level surface.

(All 125/200 models)

- Remove gear oil level check screw ❶.

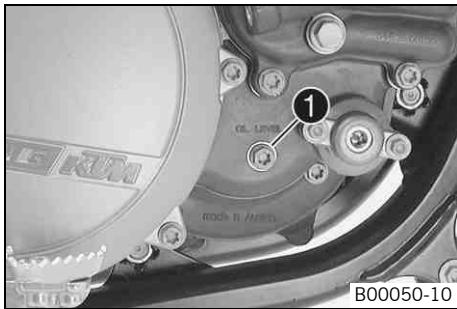

(All 250/300 models)

- Remove gear oil level check screw ❶.

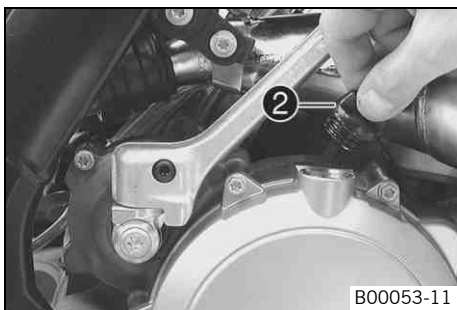

- Remove screw cap ❷.
- Add gear oil until it flows out of the hole of the gear oil level check screw.

Engine oil (15W/50) (🔧 p. 125)

- Mount and tighten the gear oil level check screw.

Guideline

Screw, gear oil level check	M6	10 Nm (7.4 lbf ft)
-----------------------------	----	--------------------

- Mount and tighten screw cap ❷.



Danger

Danger of poisoning Exhaust gases are poisonous and inhaling them may result in unconsciousness and/or death.

- When running the engine, always make sure there is sufficient ventilation, and do not start or run the engine in an enclosed space without an effective exhaust extraction system.

- Start the engine and check that it is oil-tight.

Cleaning the motorcycle

Note

Material damage Damage and destruction of components by high-pressure cleaning equipment.

- Never clean the vehicle with high-pressure cleaning equipment or a strong water-jet. The excessive pressure can penetrate electrical components, socket connects, throttle cables, and bearings, etc., and can damage or destroy these parts.

Warning



Environmental hazard Hazardous substances cause environmental damage.

- Oil, grease, filters, fuel, cleaners, brake fluid, etc., should be disposed of as stipulated in applicable regulations.

Info

If you clean the motorcycle regularly, its value and appearance will be maintained over a long period. Avoid direct sunlight on the motorcycle during cleaning.

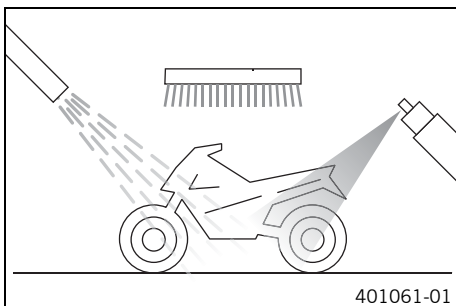

- Close off the exhaust system to prevent water from entering.
- Remove coarse dirt particles by spraying gently with water.
- Spray very dirty areas with a normal motorcycle cleaner and then clean with a soft brush.

Motorcycle cleaner (☛ p. 127)

Info

Clean the vehicle with warm water containing normal motorcycle cleaner and a soft sponge.

- After rinsing the motorcycle with a gentle water spray, allow it to dry thoroughly.
- Empty the carburetor float chamber. ☛ (☛ p. 94)



Warning

Danger of accidents Reduced braking efficiency due to wet or dirty brakes.

- Clean or dry dirty or wet brakes by riding and braking gently.

- After cleaning, take a short ride until the engine reaches operating temperature.

Info

The heat produced causes water at inaccessible positions in the engine and the brakes to evaporate.

- Push back the protection caps on the handlebar controls to allow water that may have penetrated there to evaporate.
- After the motorcycle has cooled down, lubricate all moving parts and bearings.
- Clean the chain. (☛ p. 61)
- Treat bare metal parts (except for brake discs and exhaust system) with anti-corrosion materials.

Cleaning and preserving materials for metal, rubber and plastic (☛ p. 127)

- Treat all plastic parts and powder-coated parts with a mild cleaning and care product.

Cleaning and preserving materials for metal, rubber and plastic (☛ p. 127)

(EXC, EXC Factory Edition, EXC SIX DAYS)

- Lubricate the steering lock.

Universal oil spray (☛ p. 128)

Protection for winter operation

- i Info** If the motorcycle is used in the winter, salt can be expected on the roads. Precautions need to be taken against the aggressive road salt.
If the vehicle has been used on salted roads, clean it with cold water. Warm water intensifies the effects of salt.

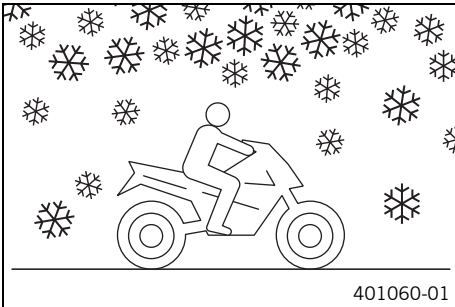

401060-01

- Clean the motorcycle. (☛ p. 100)
- Treat the engine, swingarm and all other bright and zinc-plated parts (except for the brake discs) with a wax-based corrosion inhibitor.

- i Info** Corrosion inhibitor is not permitted to come in contact with the brake discs as this would greatly reduce the braking force.
After riding on salted roads, thoroughly wash the motorcycle with cold water and dry it well.

- Clean the chain. (☛ p. 61)

Storage

**Warning**

Danger of poisoning Fuel is poisonous and a health hazard.

- Avoid contact between fuel and skin, eyes and clothing. Do not inhale fuel vapors. If fuel gets into your eyes, rinse immediately with water and contact a doctor. Wash affected skin areas immediately with soap and water. If fuel is swallowed, contact a doctor immediately. Change clothing that has come into contact with fuel. Store fuel in a suitable canister according to regulations and keep it out of the reach of children.

**Info**

If you want to put the motorcycle into storage for a longer period, take the following actions.

Before storing the motorcycle, check all parts for function and wear. If service, repairs or replacements are necessary, you should do this during the storage period (less workshop overload). In this way, you can avoid long workshop waiting times at the start of the new season.

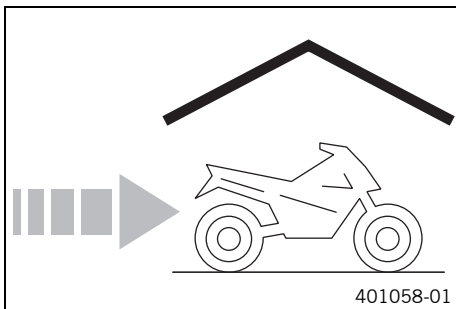

- Clean the motorcycle. (🔧 p. 100)
- Change the gear oil. 🛢️ (🔧 p. 97)
- Check the antifreeze and coolant level. (🔧 p. 88)
- Drain the fuel from the tank into a suitable container.
- Empty the carburetor float chamber. 🛢️ (🔧 p. 94)
- Check the tire air pressure. (🔧 p. 81)

(All 250/300 models)

- Remove the battery. 🛢️ (🔧 p. 83)
- Recharge the battery. 🛢️ (🔧 p. 83)

Guideline

Storage temperature of battery without direct sunlight	0... 35 °C (32... 95 °F)
--	--------------------------

- Store the vehicle in a dry location that is not subject to large fluctuations in temperature.

**Info**

KTM recommends raising the motorcycle.

- Raise the motorcycle with the lift stand. (🔧 p. 45)
- Cover the vehicle with a tarp or cover that is permeable to air.

**Info**

Do not use non-porous materials since they prevent humidity from escaping, thus causing corrosion.

Avoid running the engine for a short time only. Because the engine will not warm up sufficiently, the water vapor produced during combustion will condense, causing engine parts and the exhaust system to rust.

Putting into operation after storage

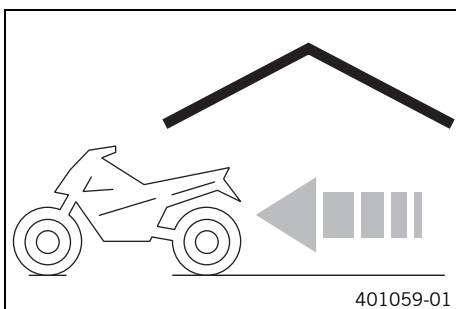

- Remove the motorcycle from the lift stand. (🔧 p. 45)

(All 250/300 models)

- Install the battery. 🛢️ (🔧 p. 83)
- Refuel. (🔧 p. 33)
- Perform checks and maintenance work when preparing the vehicle for use. (🔧 p. 31)
- Make a test ride.

Faults	Possible cause	Action
The engine cannot be cranked (electric starter) (All 250/300 models)	Operating error	– Go through the steps of starting the engine. (☛ p. 31)
	Battery discharged	– Recharge the battery. ☛ (☛ p. 83) – Check the charging voltage. ☛ – Check the closed current. ☛ – Check the alternator. ☛
	Main fuse is blown	– Remove the main fuse. (☛ p. 84) – Install the main fuse. (☛ p. 84)
	Starter relay faulty	– Check the starter relay. ☛
	Starter motor faulty	– Check the starter motor. ☛
Engine turns but does not start	Operating error	– Go through the steps of starting the engine. (☛ p. 31)
	Motorcycle was out of use for a long time and there is old fuel in the float chamber	– Empty the carburetor float chamber. ☛ (☛ p. 94)
	Fuel feed interrupted	– Check the fuel tank breather. – Clean the fuel tap. – Check/set the carburetor components.
	Spark plug oily or wet	– Clean and dry the spark plug, or change it if necessary.
	Electrode distance (plug gap) of spark plug too wide	– Adjust the plug gap. Guideline (All 125/200 models) Spark plug electrode gap 0.60 mm (0.0236 in) (All 250/300 models) Spark plug electrode gap 0.60 mm (0.0236 in)
	Fault in ignition system	– Check the ignition system. ☛
	Short circuit cable in wiring harness frayed, kill switch defective	– Check the short circuit button. ☛
	Socket connector or ignition coil is loose or oxidized	– Clean the plug-in connector and treat it with contact spray.
Engine has no idle	Idling jet blocked	– Check/set the carburetor components.
	Adjusting screws on carburetor distorted	– Carburetor - adjust the idle speed. ☛ (☛ p. 93)
	Spark plug defective	– Change the spark plug.
	Ignition system defective	– Check the ignition coil. ☛ – Check the spark plug connector. ☛
Engine does not speed up	Carburetor running over because float needle dirty or worn	– Check/set the carburetor components.
	Loose carburetor jets	– Check/set the carburetor components.
	Fault in ignition system	– Check the ignition system. ☛
Engine has too little power	Fuel feed interrupted	– Check the fuel tank breather. – Clean the fuel tap. – Check/set the carburetor components.
	Air filter very dirty	– Clean the air filter and air filter box. ☛ (☛ p. 58)
	Exhaust system leaky, deformed or too little glass fiber yarn filling in main silencer	– Check exhaust system for damage. – Change the glass fiber yarn filling of the main silencer. ☛ (☛ p. 59)
	Fault in ignition system	– Check the ignition system. ☛
	Diaphragm or reed valve housing damaged	– Check the diaphragm and reed valve housing.

Faults	Possible cause	Action
Engine stalls or is popping into the carburetor	Lack of fuel	<ul style="list-style-type: none"> - Turn handle ❶ of the fuel tap to the ON position. - Refuel. (☞ p. 33)
	Engine takes in bad air	<ul style="list-style-type: none"> - Check the intake flange and carburetor for tightness.
	Socket connector or ignition coil is loose or oxidized	<ul style="list-style-type: none"> - Clean the plug-in connector and treat it with contact spray.
Engine overheats	Too little coolant in cooling system	<ul style="list-style-type: none"> - Check the cooling system for leakage. - Check the coolant level. (☞ p. 89)
	Too little air stream	<ul style="list-style-type: none"> - Switch off engine when stationary.
	Radiator fins very dirty	<ul style="list-style-type: none"> - Clean the radiator fins.
	Foam formation in cooling system	<ul style="list-style-type: none"> - Drain the coolant. 🛠️ (☞ p. 89) - Refill with coolant. 🛠️ (☞ p. 90)
	Damaged cylinder head or cylinder head gasket	<ul style="list-style-type: none"> - Check the cylinder head or cylinder head gasket.
	Bent radiator hose	<ul style="list-style-type: none"> - Change the radiator hose. 🛠️
	Incorrect ignition point due to loose stator	<p>(All 125/200 models)</p> <ul style="list-style-type: none"> - Adjust the ignition. 🛠️
White smoke emission (steam in exhaust gas)	Damaged cylinder head or cylinder head gasket	<ul style="list-style-type: none"> - Check the cylinder head or cylinder head gasket.
Gear oil exits at the vent hose	Too much gear oil added	<ul style="list-style-type: none"> - Check the gear oil level. (☞ p. 97)
Water in the gear oil	Damaged shaft seal ring or water pump	<ul style="list-style-type: none"> - Check the shaft seal ring and water pump.

All 125 models

Design	1-cylinder 2-stroke engine, water-cooled, with reed intake and exhaust control
Displacement	124.8 cm ³ (7.616 cu in)
Stroke	54.5 mm (2.146 in)
Bore	54 mm (2.13 in)
Crankshaft bearing	1 grooved ball bearing/1 roller bearing
Conrod bearing	Needle bearing
Piston pin bearing	Needle bearing
Pistons	Aluminum cast
Piston rings	2 half keystone rings
X (upper edge of piston to upper edge of cylinder)	0... 0.10 mm (0... 0.0039 in)
Z (height of control flap)	43.7 mm (1.72 in)
Primary transmission	23:73
Clutch	Multidisc clutch in oil bath/hydraulically activated
Gearbox	6-gear, claw shifted
Transmission ratio	
1st gear	12:33
2nd gear	15:31
3rd gear	17:28
4th gear	19:26
5th gear	21:25
6th gear	20:20
Ignition	Contactless controlled fully electronic ignition with digital ignition adjustment, type Kokusan
Ignition point (BTDC)	1.4 mm (0.055 in)
Spark plug	NGK BR9 ECMVX
Spark plug electrode gap	0.60 mm (0.0236 in)
Starting aid	Kickstarter

All 200 models

Design	1-cylinder 2-stroke engine, water-cooled, with reed intake and exhaust control
Displacement	193 cm ³ (11.78 cu in)
Stroke	60 mm (2.36 in)
Bore	64 mm (2.52 in)
Crankshaft bearing	1 grooved ball bearing/1 roller bearing
Conrod bearing	Needle bearing
Piston pin bearing	Needle bearing
Pistons	Aluminum cast
Piston rings	2 rectangular rings
X (upper edge of piston to upper edge of cylinder)	0... 0.10 mm (0... 0.0039 in)
Z (height of control flap)	47 mm (1.85 in)
Primary transmission	23:73
Clutch	Multidisc clutch in oil bath/hydraulically activated
Gearbox	6-gear, claw shifted
Transmission ratio	
1st gear	13:33
2nd gear	15:31
3rd gear	17:28
4th gear	19:26
5th gear	17:19

6th gear	22:20
Ignition	Contactless controlled fully electronic ignition with digital ignition adjustment, type Kokusan
Ignition point (BTDC)	1.6 mm (0.063 in)
Spark plug	NGK BR 8 EG
Spark plug electrode gap	0.60 mm (0.0236 in)
Starting aid	Kickstarter

All 250 models

Design	1-cylinder 2-stroke engine, water-cooled, with reed intake and exhaust control
Displacement	249 cm ³ (15.19 cu in)
Stroke	72 mm (2.83 in)
Bore	66.4 mm (2.614 in)
Exhaust valve - Beginning of adjustment	5,600 rpm
Exhaust valve - end of adjustment with red auxiliary spring	7,200 rpm
Exhaust valve - end of adjustment with yellow auxiliary spring	7,900 rpm
Exhaust valve - end of adjustment with green auxiliary spring	8,400 rpm
Crankshaft bearing	1 grooved ball bearing/1 roller bearing
Conrod bearing	Needle bearing
Piston pin bearing	Needle bearing
Pistons	Aluminum cast
Piston rings	2 half keystone rings
X (upper edge of piston to upper edge of cylinder)	0... 0.10 mm (0... 0.0039 in)
Z (height of control flap)	48 mm (1.89 in)
Primary transmission	26:72
Clutch	Multidisc clutch in oil bath/hydraulically activated
Gearbox	6-gear, claw shifted
Transmission ratio	
1st gear	14:32
2nd gear	16:26
3rd gear	20:25
4th gear	22:23
5th gear	25:22
6th gear	26:20
Ignition	Contactless controlled fully electronic ignition with digital ignition adjustment, type Kokusan
Ignition point (BTDC)	1.9 mm (0.075 in)
Spark plug	NGK BR 7 ES
Spark plug electrode gap	0.60 mm (0.0236 in)
Starting aid	Kick starter and electric starter

All 300 models

Design	1-cylinder 2-stroke engine, water-cooled, with reed intake and exhaust control
Displacement	293 cm ³ (17.88 cu in)
Stroke	72 mm (2.83 in)
Bore	72 mm (2.83 in)
Exhaust valve - Beginning of adjustment	5,600 rpm
Exhaust valve - end of adjustment with red auxiliary spring	7,200 rpm
Exhaust valve - end of adjustment with yellow auxiliary spring	7,900 rpm
Exhaust valve - end of adjustment with green auxiliary spring	8,400 rpm
Crankshaft bearing	1 grooved ball bearing/1 roller bearing

Conrod bearing	Needle bearing
Piston pin bearing	Needle bearing
Pistons	Aluminum cast
Piston rings	2 rectangular rings
X (upper edge of piston to upper edge of cylinder)	0... 0.10 mm (0... 0.0039 in)
Z (height of control flap)	48 mm (1.89 in)
Primary transmission	26:72
Clutch	Multidisc clutch in oil bath/hydraulically activated
Gearbox	6-gear, claw shifted
Transmission ratio	
1st gear	14:32
2nd gear	16:26
3rd gear	20:25
4th gear	22:23
5th gear	25:22
6th gear	26:20
Ignition	Contactless controlled fully electronic ignition with digital ignition adjustment, type Kokusan
Ignition point (BTDC)	1.9 mm (0.075 in)
Spark plug	NGK BR 7 ES
Spark plug electrode gap	0.60 mm (0.0236 in)
Starting aid	Kick starter and electric starter

Capacity - transmission oil

Gear oil (All 125/200 models)	0.70 l (0.74 qt.)	Engine oil (15W/50) (☛ p. 125)
Gear oil (All 250/300 models)	0.80 l (0.85 qt.)	Engine oil (15W/50) (☛ p. 125)

Capacity - coolant

Coolant	1.2 l (1.3 qt.)	Coolant (☛ p. 125)
		Coolant (mixed ready to use) (☛ p. 125)

All 125/200 models

Screw, membrane	M4	2 Nm (1.5 lbf ft)	Loctite® 243™
Locking screw for bearing	M5	6 Nm (4.4 lbf ft)	Loctite® 243™
Screw, alternator cover	M5	5 Nm (3.7 lbf ft)	–
Screw, exhaust control cover	M5	5 Nm (3.7 lbf ft)	–
Screw, exhaust flange	M5	6 Nm (4.4 lbf ft)	–
Screw, ignition system/stator	M5	6 Nm (4.4 lbf ft)	Loctite® 222
Screw, lock washer, axle for control flap	M5	6 Nm (4.4 lbf ft)	Loctite® 243™
Screw, locking lever	M5	6 Nm (4.4 lbf ft)	Loctite® 243™
Screw, water pump wheel	M5	6 Nm (4.4 lbf ft)	Loctite® 243™
Bleeder screw, cylinder head	M6	10 Nm (7.4 lbf ft)	–
Screw, clutch cover	M6	10 Nm (7.4 lbf ft)	–
Screw, clutch slave cylinder	M6	10 Nm (7.4 lbf ft)	Loctite® 243™
Screw, clutch spring	M6	10 Nm (7.4 lbf ft)	–
Screw, engine housing	M6	10 Nm (7.4 lbf ft)	–
Screw, exhaust control	M6	10 Nm (7.4 lbf ft)	–
Screw, gear oil level check	M6	10 Nm (7.4 lbf ft)	–
Screw, intake flange/reed valve housing	M6	10 Nm (7.4 lbf ft)	–
Screw, kick starter stop plate	M6	10 Nm (7.4 lbf ft)	Loctite® 243™
Screw, shift lever	M6	14 Nm (10.3 lbf ft)	Loctite® 243™
Screw, shifting gate	M6	10 Nm (7.4 lbf ft)	Loctite® 243™
Screw, water pump cover	M6	10 Nm (7.4 lbf ft)	Loctite® 243™
Screw, cylinder head (All 125 models)	M7	18 Nm (13.3 lbf ft)	–
Axle for control flap, exhaust control	M8	Step 1 3 Nm (2.2 lbf ft) Step 2 (loosen, counter-clockwise) 1/4 turn	–
Nut, cylinder base	M8	30 Nm (22.1 lbf ft)	–
Screw, cylinder base	M8	35 Nm (25.8 lbf ft)	–
Screw, kickstarter	M8	25 Nm (18.4 lbf ft)	Loctite® 243™
Drain plug, water pump cover	M10x1	15 Nm (11.1 lbf ft)	–
Gear oil drain plug	M10x1	15 Nm (11.1 lbf ft)	–
Nut, rotor	M12x1	60 Nm (44.3 lbf ft)	–
Gear oil drain plug with magnet	M12x1.5	20 Nm (14.8 lbf ft)	–
Spark plug	M14x1.25	25 Nm (18.4 lbf ft)	–
Nut, primary gear	M16LHx1.5	130 Nm (95.9 lbf ft)	Loctite® 243™
Nut, inner clutch hub	M18x1.5	130 Nm (95.9 lbf ft)	Loctite® 243™
Nut, exhaust control, bearing support	M26x1	35 Nm (25.8 lbf ft)	–

All 250/300 models

Screw, angle lever, exhaust control	M5	6 Nm (4.4 lbf ft)	Loctite® 243™
Screw, exhaust control cover	M5	5 Nm (3.7 lbf ft)	–
Screw, ignition pulse generator	M5	6 Nm (4.4 lbf ft)	Loctite® 243™
Screw, locking lever	M5	6 Nm (4.4 lbf ft)	Loctite® 243™
Screw, retaining bracket of exhaust control	M5	7 Nm (5.2 lbf ft)	Loctite® 243™
Screw, water pump wheel	M5	6 Nm (4.4 lbf ft)	Loctite® 243™
Screw, clutch cover	M6	10 Nm (7.4 lbf ft)	–
Screw, clutch slave cylinder	M6	10 Nm (7.4 lbf ft)	Loctite® 243™
Screw, clutch spring	M6	10 Nm (7.4 lbf ft)	–

Screw, control flap, exhaust control	M6	10 Nm (7.4 lbf ft)	Loctite® 243™
Screw, engine housing	M6	10 Nm (7.4 lbf ft)	–
Screw, exhaust flange	M6	8 Nm (5.9 lbf ft)	–
Screw, gear oil level check	M6	10 Nm (7.4 lbf ft)	–
Screw, intake flange/reed valve housing	M6	10 Nm (7.4 lbf ft)	–
Screw, kick starter stop plate	M6	10 Nm (7.4 lbf ft)	Loctite® 243™
Screw, kickstarter spring	M6	10 Nm (7.4 lbf ft)	Loctite® 243™
Screw, shift drum bearing retainer	M6	10 Nm (7.4 lbf ft)	Loctite® 243™
Screw, shift drum locating	M6	10 Nm (7.4 lbf ft)	Loctite® 243™
Screw, shift lever	M6	14 Nm (10.3 lbf ft)	Loctite® 243™
Screw, starter motor	M6	8 Nm (5.9 lbf ft)	–
Screw, stator	M6	8 Nm (5.9 lbf ft)	Loctite® 243™
Screw, water pump cover	M6	10 Nm (7.4 lbf ft)	–
Screw, cylinder head	M8	27 Nm (19.9 lbf ft)	–
Screw, kickstarter	M8	25 Nm (18.4 lbf ft)	Loctite® 2701
Screw, shift drum locating	M8	25 Nm (18.4 lbf ft)	Loctite® 243™
Nut, cylinder base	M10	35 Nm (25.8 lbf ft)	–
Drain plug, water pump cover	M10x1	15 Nm (11.1 lbf ft)	–
Nut, rotor	M12x1	60 Nm (44.3 lbf ft)	–
Gear oil drain plug with magnet	M12x1.5	20 Nm (14.8 lbf ft)	–
Spark plug	M14x1.25	25 Nm (18.4 lbf ft)	–
Nut, inner clutch hub	M18x1.5	100 Nm (73.8 lbf ft)	Loctite® 2701
Nut, primary gear	M18LHx1.5	150 Nm (110.6 lbf ft)	Loctite® 243™

All 125 models

Carburetor type	KEIHIN PWK 36S AG
Carburetor identification number	FK0191
Needle position	5th position from top
Jet needle	N84I (NOZF / NOZG / NOZH)
Main jet	140 (168 / 170 / 172)
Idling jet	38X38 (45)
Starting jet	50 (85)
Idle air adjusting screw	
Open	2.5 turns
Throttle slide	7 with cut-out
Slide stop	-

200 EXC EU

Carburetor type	KEIHIN PWK 36S AG
Carburetor identification number	FK0211
Needle position	4th position from top
Jet needle	N84I (NOZH / NOZI / NOZJ)
Main jet	100 (160 / 162)
Idling jet	35x35 (42)
Starting jet	50 (85)
Idle air adjusting screw	
Open	1.5 turns
Throttle slide	7 with cut-out
Slide stop	Present

200 EXC AUS

Carburetor type	KEIHIN PWK 36S AG
Carburetor identification number	FK0121
Needle position	3rd position from top
Jet needle	R1475J (NOZH / NOZI / NOZJ)
Main jet	162 (160)
Idling jet	35 (42)
Starting jet	85
Idle air adjusting screw	
Open	1.0 turn
Throttle slide	7 with cut-out
Slide stop	Present

200 XC-W USA

Carburetor type	KEIHIN PWK 36S AG
Carburetor identification number	BC2 0
Needle position	4th position from top
Jet needle	NOZI (NOZH / NOZJ)
Main jet	160 (162)
Idling jet	42
Starting jet	85
Idle air adjusting screw	
Open	2.0 turns
Throttle slide	7 with cut-out
Slide stop	-

All 250 EXC EU models

Carburetor type	KEIHIN PWK 36S AG
Carburetor identification number	FK0251
Needle position	3rd position from top
Jet needle	N84K (N8RW / N8RJ / N8RK)
Main jet	115 (162 / 165)
Idling jet	38X38 (35)
Starting jet	50 (85)
Idle air adjusting screw	
Open	1.75 turns
Throttle slide	7 with cut-out
Slide stop	Present

250 EXC AUS

Carburetor type	KEIHIN PWK 36S AG
Carburetor identification number	3600C
Needle position	1st position from top
Jet needle	N3CJ (N8RW / N8RJ / N8RK / N2ZK / N2ZJ / N2ZL)
Main jet	160 (162 / 165)
Idling jet	35
Starting jet	85
Idle air adjusting screw	
Open	3.5 turns
Throttle slide	7 with cut-out
Slide stop	Present

250 XC-W USA

Carburetor type	KEIHIN PWK 36S AG
Carburetor identification number	BC4 0
Needle position	4th position from top
Jet needle	N8RJ (N8RW / N8RK)
Main jet	165 (162)
Idling jet	35
Starting jet	85
Idle air adjusting screw	
Open	2.0 turns
Throttle slide	7 with cut-out
Slide stop	-

All 300 EXC EU models

Carburetor type	KEIHIN PWK 36S AG
Carburetor identification number	FK0261
Needle position	3rd position from top
Jet needle	N84K (N2ZJ / N2ZK / N2ZL)
Main jet	115 (162 / 165)
Idling jet	38X38 (35)
Starting jet	50 (85)
Idle air adjusting screw	
Open	1.75 turns
Throttle slide	7 with cut-out
Slide stop	Present

300 EXC AUS

Carburetor type	KEIHIN PWK 36S AG
Carburetor identification number	3600C
Needle position	1st position from top
Jet needle	N3CJ (N8RW / N8RJ / N8RK / N2ZK / N2ZJ / N2ZL)
Main jet	160 (162 / 165)
Idling jet	35
Starting jet	85
Idle air adjusting screw	
Open	3.5 turns
Throttle slide	7 with cut-out
Slide stop	Present

300 XC-W USA

Carburetor type	KEIHIN PWK 36S AG
Carburetor identification number	BC5 0
Needle position	4th position from top
Jet needle	N2ZK (N2ZJ / N2ZL)
Main jet	165 (162)
Idling jet	35
Starting jet	85
Idle air adjusting screw	
Open	2.0 turns
Throttle slide	7 with cut-out
Slide stop	-

Carburetor configuration (All 125 models)

 **Danger**
Loss of approval for road use and insurance coverage The motorcycle is authorized for public road traffic in the homologous (reduced) version only.

- In the derestricted version, the motorcycle must be used only on closed off property remote from public road traffic.

KEIHIN PWK 36S AG							
M/FT ASL ↓	TEMP →	-20°C ... -7°C	-6°C ... 5°C	6°C ... 15°C	16°C ... 24°C	25°C ... 36°C	37°C ... 49°C
		-2°F ... 20°F	19°F ... 41°F	42°F ... 60°F	61°F ... 78°F	79°F ... 98°F	99°F ... 120°F
3.000 m 10,000 ft ↑ 2.301 m 7,501 ft	ASO IJ NDL POS MJ	1,5 45 NOZG 4 170	1,5 42 NOZG 4 168	2 42 NOZH 3 165	2,5 40 NOZH 3 162	3 40 NOZI 2 160	
2.300 m 7,500 ft ↑ 1.501 m 5,001 ft	ASO IJ NDL POS MJ	1,5 45 NOZF 4 172	1,5 45 NOZG 4 170	1,5 42 NOZG 4 168	2 42 NOZH 3 165	2,5 40 NOZH 3 162	3 40 NOZI 2 160
1.500 m 5,000 ft ↑ 751 m 2,501 ft	ASO IJ NDL POS MJ	1,5 48 NOZF 4 175	1,5 45 NOZF 4 172	1,5 45 NOZG 4 170	1,5 42 NOZG 4 168	2 42 NOZH 3 165	2,5 40 NOZH 3 162
750 m 2,500 ft ↑ 301 m 1,001 ft	ASO IJ NDL POS MJ	1 48 NOZE 5 178	1,5 48 NOZF 4 175	1,5 45 NOZF 4 172	1,5 45 NOZG 4 170	1,5 42 NOZG 4 168	2 42 NOZH 3 165
300 m 1,000 ft ↑ 0 m 0 ft	ASO IJ NDL POS MJ	1 50 NOZE 5 180	1 48 NOZE 5 178	1,5 48 NOZF 4 175	1,5 45 NOZF 4 172	1,5 45 NOZG 4 170	1,5 42 NOZG 4 168

401041-01

M/FT ASL	Sea level
TEMP	Temperature
ASO	Idle air adjusting screw is open
IJ	Idling jet
NDL	Needle
POS	Needle position from above
MJ	Main jet

Does not apply to sand surfaces!

Carburetor configuration (All 200 models) ↘

Danger
Loss of approval for road use and insurance coverage The motorcycle is authorized for public road traffic in the homologous (reduced) version only.

- In the derestricted version, the motorcycle must be used only on closed off property remote from public road traffic.

KEIHIN PWK 36S AG							
M/FT ASL ↓	TEMP →	-20°C ... -7°C	-6°C ... 5°C	6°C ... 15°C	16°C ... 24°C	25°C ... 36°C	37°C ... 49°C
		-2°F ... 20°F	19°F ... 41°F	42°F ... 60°F	61°F ... 78°F	79°F ... 98°F	99°F ... 120°F
3.000 m 10,000 ft ↑	ASO IJ NDL POS MJ	2 42 NOZI 4 160	2 42 NOZI 3 158	2,5 42 NOZJ 3 155	2,5 40 NOZJ 2 152	3 40 NOZK 2 150	
2.300 m 7,500 ft ↑	ASO IJ NDL POS MJ	2 45 NOZI 4 162	2 42 NOZI 4 160	2 42 NOZI 3 158	2,5 42 NOZJ 3 155	2,5 40 NOZJ 2 152	3 40 NOZK 2 150
1.500 m 5,000 ft ↑	ASO IJ NDL POS MJ	1,5 45 NOZH 4 165	2 45 NOZI 4 162	2 42 NOZI 4 160	2 42 NOZI 3 158	2,5 42 NOZJ 3 155	2,5 40 NOZJ 2 152
750 m 2,500 ft ↑	ASO IJ NDL POS MJ	1,5 48 NOZH 4 168	1,5 45 NOZH 4 165	2 45 NOZI 4 162	2 42 NOZI 4 160	2 42 NOZI 3 158	2,5 42 NOZJ 3 155
300 m 1,000 ft ↑	ASO IJ NDL POS MJ	1 48 NOZG 5 170	1,5 48 NOZH 4 168	1,5 45 NOZH 4 165	2 45 NOZI 4 162	2 42 NOZI 4 160	2 42 NOZI 3 158

401042-01

M/FT ASL	Sea level
TEMP	Temperature
ASO	Idle air adjusting screw is open
IJ	Idling jet
NDL	Needle
POS	Needle position from above
MJ	Main jet

Does not apply to sand surfaces!

Carburetor configuration (All 250 models) ↘

Danger
Loss of approval for road use and insurance coverage The motorcycle is authorized for public road traffic in the homologous (reduced) version only.

- In the derestricted version, the motorcycle must be used only on closed off property remote from public road traffic.

KEIHIN PWK 36S AG							
M/FT ASL ↓	TEMP →	-20°C ... -7°C	-6°C ... 5°C	6°C ... 15°C	16°C ... 24°C	25°C ... 36°C	37°C ... 49°C
		-2°F ... 20°F	19°F ... 41°F	42°F ... 60°F	61°F ... 78°F	79°F ... 98°F	99°F ... 120°F
3.000 m 10,000 ft ↑	ASO IJ NDL POS MJ	2 35 N8RJ 4 165	2 35 N8RJ 3 165	2,5 35 N8RK 3 162	2,5 35 N8RK 2 160	3 35 N8RL 2 158	
2.300 m 7,500 ft ↑	ASO IJ NDL POS MJ	1,5 35 N8RW 4 168	2 35 N8RJ 4 165	2 35 N8RJ 3 165	2,5 35 N8RK 3 162	2,5 35 N8RK 2 160	3 35 N8RL 2 158
1.500 m 5,000 ft ↑	ASO IJ NDL POS MJ	1,5 38 N8RH 4 170	1,5 35 N8RW 4 168	2 35 N8RJ 4 165	2 35 N8RJ 3 165	2,5 35 N8RK 3 162	2,5 35 N8RK 2 160
750 m 2,500 ft ↑	ASO IJ NDL POS MJ	1 40 N8RH 5 172	1,5 38 N8RH 4 170	1,5 35 N8RW 4 168	2 35 N8RJ 4 165	2 35 N8RJ 3 165	2,5 35 N8RK 3 162
300 m 1,000 ft ↑	ASO IJ NDL POS MJ	1 40 N8RG 5 175	1 40 N8RH 5 172	1,5 38 N8RH 4 170	1,5 35 N8RW 4 168	2 35 N8RJ 4 165	2 35 N8RJ 3 165

401043-01

M/FT ASL	Sea level
TEMP	Temperature
ASO	Idle air adjusting screw is open
IJ	Idling jet
NDL	Needle
POS	Needle position from above
MJ	Main jet

Does not apply to sand surfaces!

Carburetor configuration (All 300 models) ↘

Danger
Loss of approval for road use and insurance coverage The motorcycle is authorized for public road traffic in the homologous (reduced) version only.

- In the derestricted version, the motorcycle must be used only on closed off property remote from public road traffic.

KEIHIN PWK 36S AG							
M/FT ASL ↓	TEMP →	-20°C ... -7°C	-6°C ... 5°C	6°C ... 15°C	16°C ... 24°C	25°C ... 36°C	37°C ... 49°C
		-2°F ... 20°F	19°F ... 41°F	42°F ... 60°F	61°F ... 78°F	79°F ... 98°F	99°F ... 120°F
3.000 m 10,000 ft ↑ 2.301 m 7,501 ft	ASO IJ NDL POS MJ	2 35 N2ZK 4 165	2 35 N2ZK 3 165	2,5 35 N2ZL 3 162	3 35 N2ZL 2 160	3,5 35 N2ZL 2 158	
2.300 m 7,500 ft ↑ 1.501 m 5,001 ft	ASO IJ NDL POS MJ	1,5 35 N2ZJ 4 168	2 35 N2ZK 4 165	2 35 N2ZK 3 165	2,5 35 N2ZL 3 162	3 35 N2ZL 2 160	3,5 35 N2ZL 2 158
1.500 m 5,000 ft ↑ 751 m 2,501 ft	ASO IJ NDL POS MJ	1,5 38 N2ZW 4 170	1,5 35 N2ZJ 4 168	2 35 N2ZK 4 165	2 35 N2ZK 3 165	2,5 35 N2ZL 3 162	3 35 N2ZL 2 160
750 m 2,500 ft ↑ 301 m 1,001 ft	ASO IJ NDL POS MJ	1 40 N2ZW 5 172	1,5 38 N2ZW 4 170	1,5 35 N2ZJ 4 168	2 35 N2ZK 4 165	2 35 N2ZK 3 165	2,5 35 N2ZL 3 162
300 m 1,000 ft ↑ 0 m 0 ft	ASO IJ NDL POS MJ	1 40 N2ZH 5 175	1 40 N2ZW 5 172	1,5 38 N2ZW 4 170	1,5 35 N2ZJ 4 168	2 35 N2ZK 4 165	2 35 N2ZK 3 165

401044-01

M/FT ASL	Sea level
TEMP	Temperature
ASO	Idle air adjusting screw is open
IJ	Idling jet
NDL	Needle
POS	Needle position from above
MJ	Main jet

Does not apply to sand surfaces!

General carburetor configuration ↴

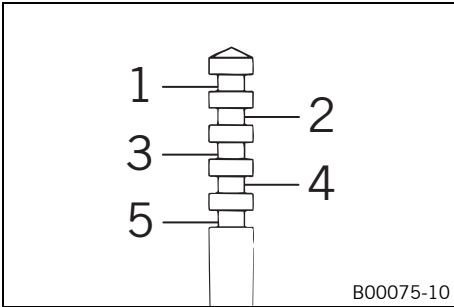

1... 5	Needle position from above
--------	----------------------------

The five needle positions are shown here.
 The carburetor configuration depends on the defined ambient and operating conditions.

Frame	Central tube frame made of chrome molybdenum steel tubing	
Fork	WP Suspension Up Side Down 4860 MXMA PA	
Suspension travel		
Front	300 mm (11.81 in)	
Rear	335 mm (13.19 in)	
Fork offset (All 125/200 EXC models)	22 mm (0.87 in)	
Fork offset (250/300 EXC AUS, 250 EXC EU, 300 EXC EU)	20 mm (0.79 in)	
Fork offset (250/300 EXC SIX DAYS, 250/300 EXC Factory Edition)	19 mm (0.75 in)	
Fork offset (200 XC-W USA)	22 mm (0.87 in)	
Fork offset (250/300 XC-W)	19 mm (0.75 in)	
Shock absorber	WP Suspension PDS 5018 DCC	
Brake system	Disc brakes, brake calipers on floating bearings	
Brake discs - diameter		
Front	260 mm (10.24 in)	
Rear	220 mm (8.66 in)	
Brake discs - wear limit		
Front	2.5 mm (0.098 in)	
Rear	3.5 mm (0.138 in)	
Tire air pressure, road (EXC, EXC Factory Edition, EXC SIX DAYS)		
Front	1.5 bar (22 psi)	
Rear	2.0 bar (29 psi)	
Tire air pressure off road		
Front	1.0 bar (15 psi)	
Rear	1.0 bar (15 psi)	
Secondary ratio (All 125 models)	14:42 (13:50)	
Secondary ratio (200 EXC EU, 200 EXC AUS)	14:42 (14:45)	
Secondary ratio (All 250/300 EXC models)	13:40 (13:50)	
Secondary ratio (250/300 XC-W)	13:50	
Secondary ratio (200 XC-W USA)	14:48	
Chain	5/8 x 1/4"	
Rear sprockets available	38, 40, 42, 45, 48, 49, 50, 51, 52	
Steering head angle	63.5°	
Wheelbase (All 125/200 models)	1,471±10 mm (57.91±0.39 in)	
Wheelbase (All 250/300 models)	1,475±10 mm (58.07±0.39 in)	
Seat height unloaded	985 mm (38.78 in)	
Ground clearance unloaded (All 125/200 models)	390 mm (15.35 in)	
Ground clearance unloaded (All 250/300 models)	385 mm (15.16 in)	
Weight without fuel, approx. (All 125/200 EXC models)	97 kg (214 lb.)	
Weight without fuel, approx. (200 XC-W USA)	94.8 kg (209 lb.)	
Weight without fuel, approx. (All 250 EXC EU models, 250 EXC AUS)	103 kg (227 lb.)	
Weight without fuel, approx. (All 300 EXC EU models, 300 EXC AUS)	103.1 kg (227.3 lb.)	
Weight without fuel, approx. (250/300 XC-W)	100.4 kg (221.3 lb.)	
Maximum permissible front axle load	145 kg (320 lb.)	
Maximum permissible rear axle load	190 kg (419 lb.)	
Maximum permissible overall weight	335 kg (739 lb.)	
Battery (All 250/300 models)	YTX4L-BS	Battery voltage: 12 V Nominal capacity: 3 Ah maintenance-free

Lighting equipment

Headlight (EXC, EXC Factory Edition, EXC SIX DAYS)	S2 / socket BA20d	12 V 35/35 W
Parking light (EXC, EXC Factory Edition, EXC SIX DAYS)	W5W / socket W2.1x9.5d	12 V 5 W
Indicator lamps (EXC, EXC Factory Edition, EXC SIX DAYS)	W2.3W / socket W2x4.6d	12 V 2.3 W
Turn signal (EXC, EXC Factory Edition, EXC SIX DAYS)	R10W / socket BA15s	12 V 10 W
Brake/tail light (EXC, EXC Factory Edition, EXC SIX DAYS)	LED	
License plate lamp (EXC, EXC Factory Edition, EXC SIX DAYS)	W5W / socket W2.1x9.5d	12 V 5 W

Tires

Validity	Front tire	Rear tire
(All 125/200 EXC models)	90/90 - 21 M/C 54M M+S TT Metzeler MCE 6 DAYS EXTREME	120/90 - 18 M/C 65M M+S TT Metzeler MCE 6 DAYS EXTREME
(All 250/300 EXC models)	90/90 - 21 M/C 54M M+S TT Metzeler MCE 6 DAYS EXTREME	140/80 - 18 M/C 70M M+S TT Metzeler MCE 6 DAYS EXTREME
(200 XC-W USA)	80/100 - 21 51M TT Bridgestone M59	100/100 - 18 59M TT Bridgestone M402
(250/300 XC-W)	80/100 - 21 51M TT Bridgestone M59	110/100 - 18 64M TT Bridgestone M402

Additional information is available in the Service section under:
<http://www.ktm.com>

Capacity - fuel

Total fuel tank capacity, approx. (EXC EU, EXC SIX DAYS, EXC Factory Edition)	9.5 l (2.51 US gal)	Super unleaded gasoline, mixed with 2-stroke engine oil (1:60) (☛ p. 126)
Total fuel tank capacity, approx. (EXC AUS, XC-W)	11.5 l (3.04 US gal)	Super unleaded gasoline, mixed with 2-stroke engine oil (1:60) (☛ p. 126)
Fuel reserve, approx.	2 l (2 qt.)	

All 125/200 models

Fork part number	14.18.7J.02	
Fork	WP Suspension Up Side Down 4860 MXMA PA	
Compression damping		
Comfort	26 clicks	
Standard	22 clicks	
Sport	18 clicks	
Rebound damping		
Comfort	24 clicks	
Standard	20 clicks	
Sport	20 clicks	
Spring preload - Preload Adjuster		
Comfort	0 turn	
Standard	2 turns	
Sport	4 turns	
Spring length with preload spacer(s)		
Weight of rider: 65... 75 kg (143... 165 lb.)	510 mm (20.08 in)	
Weight of rider: 75... 85 kg (165... 187 lb.)	513 mm (20.2 in)	
Weight of rider: 85... 95 kg (187... 209 lb.)	510 mm (20.08 in)	
Spring rate		
Weight of rider: 65... 75 kg (143... 165 lb.)	3.8 N/mm (21.7 lb/in)	
Weight of rider: 75... 85 kg (165... 187 lb.)	4.0 N/mm (22.8 lb/in)	
Weight of rider: 85... 95 kg (187... 209 lb.)	4.2 N/mm (24 lb/in)	
Fork length	940 mm (37.01 in)	
Air chamber length	110 ⁺²⁰ ₋₃₀ mm (4.33 ^{+0.79} _{-1.18} in)	
Fork oil per fork leg	628 ml (21.23 fl. oz.)	Fork oil (SAE 5) (☛ p. 125)

All 250/300 models

Fork part number	14.18.7J.04	
Fork	WP Suspension Up Side Down 4860 MXMA PA	
Compression damping		
Comfort	26 clicks	
Standard	22 clicks	
Sport	18 clicks	
Rebound damping		
Comfort	24 clicks	
Standard	20 clicks	
Sport	20 clicks	
Spring preload - Preload Adjuster		
Comfort	0 turn	
Standard	2 turns	
Sport	4 turns	
Spring length with preload spacer(s)		
Weight of rider: 65... 75 kg (143... 165 lb.)	510 mm (20.08 in)	
Weight of rider: 75... 85 kg (165... 187 lb.)	513 mm (20.2 in)	
Weight of rider: 85... 95 kg (187... 209 lb.)	510 mm (20.08 in)	
Spring rate		
Weight of rider: 65... 75 kg (143... 165 lb.)	4.0 N/mm (22.8 lb/in)	
Weight of rider: 75... 85 kg (165... 187 lb.)	4.2 N/mm (24 lb/in)	
Weight of rider: 85... 95 kg (187... 209 lb.)	4.4 N/mm (25.1 lb/in)	
Fork length	940 mm (37.01 in)	

Air chamber length	110 ⁺²⁰ ₋₃₀ mm (4.33 ^{+0.79} _{-1.18} in)	
Fork oil per fork leg	626 ml (21.17 fl. oz.)	Fork oil (SAE 5) (☛ p. 125)

All 125/200 models

Shock absorber part number	12.18.7J.02
Shock absorber	WP Suspension PDS 5018 DCC
Compression damping, low-speed	
Comfort	22 clicks
Standard	20 clicks
Sport	15 clicks
Compression damping, high-speed	
Comfort	2 turns
Standard	1.5 turns
Sport	1.25 turns
Rebound damping	
Comfort	26 clicks
Standard	24 clicks
Sport	22 clicks
Spring preload	6 mm (0.24 in)
Spring rate	
Weight of rider: 65... 75 kg (143... 165 lb.)	63 N/mm (360 lb/in)
Weight of rider: 75... 85 kg (165... 187 lb.)	66 N/mm (377 lb/in)
Weight of rider: 85... 95 kg (187... 209 lb.)	69 N/mm (394 lb/in)
Spring length	250 mm (9.84 in)
Gas pressure	10 bar (145 psi)
Static sag	35 mm (1.38 in)
Riding sag	105 mm (4.13 in)
Fitted length	411 mm (16.18 in)
Shock absorber oil (☛ p. 126)	SAE 2,5

All 250/300 models

Shock absorber part number	12.18.7J.04
Shock absorber	WP Suspension PDS 5018 DCC
Compression damping, low-speed	
Comfort	22 clicks
Standard	20 clicks
Sport	15 clicks
Compression damping, high-speed	
Comfort	2 turns
Standard	1.5 turns
Sport	1.25 turns
Rebound damping	
Comfort	26 clicks
Standard	24 clicks
Sport	22 clicks
Spring preload	8 mm (0.31 in)
Spring rate	
Weight of rider: 65... 75 kg (143... 165 lb.)	66 N/mm (377 lb/in)
Weight of rider: 75... 85 kg (165... 187 lb.)	69 N/mm (394 lb/in)
Weight of rider: 85... 95 kg (187... 209 lb.)	72 N/mm (411 lb/in)
Spring length	250 mm (9.84 in)
Gas pressure	10 bar (145 psi)
Static sag	35 mm (1.38 in)
Riding sag	105 mm (4.13 in)
Fitted length	411 mm (16.18 in)

Shock absorber oil (☛ p. 126)	SAE 2,5
-------------------------------	---------

Spoke nipple, front wheel	M4.5	5... 6 Nm (3.7... 4.4 lbf ft)	–
Screw, spoiler on fuel tank (XC-W)	M5x12	1.5 Nm (1.11 lbf ft)	–
Spoke nipple, rear wheel	M5	5... 6 Nm (3.7... 4.4 lbf ft)	–
Remaining nuts, chassis	M6	15 Nm (11.1 lbf ft)	–
Remaining screws, chassis	M6	10 Nm (7.4 lbf ft)	–
Screw, ball joint of push rod on foot brake cylinder	M6	10 Nm (7.4 lbf ft)	–
Screw, chain sliding guard	M6	6 Nm (4.4 lbf ft)	Loctite® 243™
Screw, front brake disc	M6	14 Nm (10.3 lbf ft)	Loctite® 243™
Screw, rear brake disc	M6	14 Nm (10.3 lbf ft)	Loctite® 243™
Screw, shock absorber adjusting ring	M6	5 Nm (3.7 lbf ft)	–
Nut, foot brake lever stop	M8	20 Nm (14.8 lbf ft)	–
Nut, rear sprocket screw	M8	35 Nm (25.8 lbf ft)	Loctite® 2701
Nut, rim lock	M8	10 Nm (7.4 lbf ft)	–
Remaining nuts, chassis	M8	30 Nm (22.1 lbf ft)	–
Remaining screws, chassis	M8	25 Nm (18.4 lbf ft)	–
Screw, bottom triple clamp (EXC EU/AUS)	M8	15 Nm (11.1 lbf ft)	–
Screw, bottom triple clamp (EXC SIX DAYS, EXC Factory Edition, XC-W)	M8	12 Nm (8.9 lbf ft)	–
Screw, chain sliding piece	M8	15 Nm (11.1 lbf ft)	–
Screw, engine brace	M8	33 Nm (24.3 lbf ft)	–
Screw, fork stub	M8	15 Nm (11.1 lbf ft)	–
Screw, front brake caliper	M8	25 Nm (18.4 lbf ft)	Loctite® 243™
Screw, handlebar clamp	M8	20 Nm (14.8 lbf ft)	–
Screw, side stand attachment	M8	40 Nm (29.5 lbf ft)	Loctite® 2701
Screw, subframe	M8	35 Nm (25.8 lbf ft)	Loctite® 2701
Screw, top steering stem (EXC EU/AUS)	M8	20 Nm (14.8 lbf ft)	–
Screw, top steering stem (EXC SIX DAYS, EXC Factory Edition, XC-W)	M8	17 Nm (12.5 lbf ft)	Loctite® 243™
Screw, top triple clamp (EXC EU/AUS)	M8	20 Nm (14.8 lbf ft)	–
Screw, top triple clamp (EXC SIX DAYS, EXC Factory Edition, XC-W)	M8	17 Nm (12.5 lbf ft)	–
Engine bracket screw	M10	60 Nm (44.3 lbf ft)	–
Remaining nuts, chassis	M10	50 Nm (36.9 lbf ft)	–
Remaining screws, chassis	M10	45 Nm (33.2 lbf ft)	–
Screw, handlebar support	M10	40 Nm (29.5 lbf ft)	Loctite® 243™
Screw, bottom shock absorber	M12	80 Nm (59 lbf ft)	Loctite® 2701
Screw, top shock absorber	M12	80 Nm (59 lbf ft)	Loctite® 2701
Nut, seat fixing	M12x1	20 Nm (14.8 lbf ft)	–
Nut, swingarm pivot	M16x1.5	100 Nm (73.8 lbf ft)	–
Nut, rear wheel spindle	M20x1.5	80 Nm (59 lbf ft)	–
Screw, top steering head	M20x1.5	10 Nm (7.4 lbf ft)	–
Screw-in nozzles, cooling system	M20x1.5	12 Nm (8.9 lbf ft)	Loctite® 243™
Screw, front wheel spindle	M24x1.5	45 Nm (33.2 lbf ft)	–

2-stroke engine oil

According to

- JASO FC (☛ p. 129)

Guideline

- Only use high quality 2-stroke engine oil of a well-known brand. KTM recommends **Motorex®** products.

Fully synthetic

Supplier

Motorex®

- **Cross Power 2T**

Brake fluid DOT 4 / DOT 5.1

According to

- DOT

Guideline

- Use only brake fluid that complies with the specified standard (see specifications on the container) and that possesses the corresponding properties. KTM recommends **Castrol** and **Motorex®** products.

Supplier

Castrol

- **RESPONSE BRAKE FLUID SUPER DOT 4**

Motorex®

- **Brake Fluid DOT 5.1**

Coolant

Guideline

- Use only suitable coolant (also in countries with high temperatures). Use of low-quality antifreeze can lead to corrosion and foaming. KTM recommends **Motorex®** products.

Mixture ratio

Antifreeze protection: -25... -45 °C (-13... -49 °F)	50 % corrosion inhibitor/antifreeze 50 % distilled water
--	---

Coolant (mixed ready to use)

Antifreeze	-40 °C (-40 °F)
------------	-----------------

Supplier

Motorex®

- **Anti Freeze**

Engine oil (15W/50)

According to

- JASO T903 MA (☛ p. 129)
- SAE (☛ p. 129) (15W/50)

Guideline

- Use only engine oils that comply with the specified standards (see specifications on the container) and that possess the corresponding properties. KTM recommends **Motorex®** products.

Supplier

Motorex®

- **Top Speed 4T**

Fork oil (SAE 5)

According to

- SAE (☛ p. 129) (SAE 5)

Guideline

- Use only oils that comply with the specified standards (see specifications on the container) and that possess the corresponding properties. KTM recommends **Motorex®** products.

Supplier

Motorex®

- **Racing Fork Oil**

Hydraulic fluid (15)

According to

- ISO VG (15)

Guideline

- Use only hydraulic oil that complies with the specified standard (see specifications on the container) and that possesses the corresponding properties. KTM recommends **Motorex®** products.

Supplier

Motorex®

- Hydraulic Fluid 75

Shock absorber oil (SAE 2,5) (50180342S1)

According to

- SAE (☛ p. 129) (SAE 2,5)

Guideline

- Use only oils that comply with the specified standards (see specifications on the container) and that possess the corresponding properties.

Super unleaded gasoline, mixed with 2-stroke engine oil (1:60)

According to

- DIN EN 228
- JASO FC (☛ p. 129) (1:60)

Mixture ratio

1:60	2-stroke engine oil (☛ p. 125) Super unleaded (ROZ 95 / RON 95 / PON 91)
------	---

Air filter cleaner**Guideline**

- KTM recommends **Motorex®** products.

Supplier**Motorex®**

- **Twin Air Dirt Bio Remover**

Chain cleaner**Guideline**

- KTM recommends **Motorex®** products.

Supplier**Motorex®**

- **Chain Clean**

Cleaning and preserving materials for metal, rubber and plastic**Guideline**

- KTM recommends **Motorex®** products.

Supplier**Motorex®**

- **Protect & Shine**

High viscosity grease**Guideline**

- KTM recommends **SKF®** products.

Supplier**SKF®**

- **LGHB 2**

Long-life grease**Guideline**

- KTM recommends **Motorex®** products.

Supplier**Motorex®**

- **Bike Grease 2000**

Motorcycle cleaner**Guideline**

- KTM recommends **Motorex®** products.

Supplier**Motorex®**

- **Moto Clean 900**

Off-road chain spray**Guideline**

- KTM recommends **Motorex®** products.

Supplier**Motorex®**

- **Chainlube Offroad**

Oil for foam air filter**Guideline**

- KTM recommends **Motorex®** products.

Supplier**Motorex®**

- **Twin Air Liquid Bio Power**

Universal oil spray

Guideline

- KTM recommends **Motorex®** products.

Supplier

Motorex®

- **Joker 440 Synthetic**

JASO FC

JASO FC is a classification for a 2-stroke engine oil that was specifically developed for the extreme demands of racing. Thanks to first rate synthetic esters and specially designed additives, superb combustion is achieved even under extreme operating conditions.

JASO T903 MA

Different technical development directions required a new specification for 4-stroke motorcycles – the JASO T903 MA Standard. Earlier, engine oils from the automobile industry were used for 4-stroke motorcycles because there was no separate motorcycle specification. Whereas long service intervals are demanded for automobile engines, high performance at high engine speeds are in the foreground for motorcycle engines. With most motorcycles, the gearbox and the clutch are lubricated with the same oil as the engine. The JASO MA Standard meets these special requirements.

SAE

The SAE viscosity classes were defined by the Society of Automotive Engineers and are used for classifying oils according to their viscosity. The viscosity describes only one property of oil and says nothing about quality.

A

Accessories 6

Air filter

 cleaning 58

 installing 57

 removing 57

Air filter box

 cleaning 58

Air filter box lid

 installing 57

 removing 57

Antifreeze

 checking 88

B

Basic chassis setting

 checking with rider's weight 37

Battery

 installing 83

 recharging 83

 removing 83

Brake discs

 checking 70

Brake fluid

 front brake, adding 70

 rear brake, adding 74

Brake fluid level

 front brake, checking 70

 rear brake, checking 74

Brake linings

 front brake, changing 72

 front brake, checking 71

 rear brake, changing 76

 rear brake, checking 75

 rear brake, installing 76

 rear brake, removing 75

C

Carburetor 92

 float chamber, emptying 94

 idle speed, adjusting 93

Chain

 checking 62

 cleaning 61

Chain guide

 adjusting 65

 checking 62

Chain tension

 adjusting 64

 checking 62

Chassis number 10

Choke 12, 23

Cleaning, care 100-101

Clutch

 fluid level, checking 66

 fluid, changing 67

Clutch lever 12

 basic position, adjusting 66

Compression damping

 fork, adjusting 41

Compression damping, high-speed

 shock absorber, adjusting 37

Compression damping, low-speed

 shock absorber, adjusting 38

Coolant

 draining 89

 refilling 90

Coolant level

 checking 88-89

Cooling system 88

D

Difficult operating conditions 27

 dry sand 27

 high temperatures 30

 low temperatures 30

 muddy surfaces 29

 riding at low speeds 30

 snow 30

 wet sand 28

 wet surfaces 29

E

Electric starter button 14

Emergency OFF switch 14

Engine

 running in 27

Engine characteristic

 auxiliary spring 95

 auxiliary spring, setting 95

Engine number 11

Engine sprocket

 checking 62

Environment 7

F

Filler cap

 closing 23

 opening 22

Filling up

 fuel 33

Foot brake lever 24

 basic position, adjusting 73

Foot brake pedal

 free travel, checking 73

Fork

 basic setting, checking 41

Fork legs

 bleeding 45

 dust boots, cleaning 46

 installing 47

 removing 46

Fork part number 11

Fork protector

 installing 48

 removing 48

Front fender
 installing 55
 removing 54

Front wheel
 installing 78
 removing 78

Fuel tank
 installing 60
 removing 59

Fuel tap 22

Fuel, oils, etc. 6

Fuse
 main fuse, installing 84
 main fuse, removing 84

G

Gear oil
 adding 99
 changing 97
 draining 98
 refilling 98

Gear oil level
 checking 97

H

Hand brake lever 12
 basic position, adjusting 69
 free travel, adjusting 69
 free travel, checking 69

Handlebar position 43
 adjusting 43

Headlight
 range, adjusting 87

Headlight bulb
 changing 86

Headlight mask with headlight
 installing 85
 removing 85

Headlight setting
 checking 86

Horn button 13

K

Key number 10

Kickstarter 23

L

Light switch 13-14

Lower triple clamp
 installing 49, 51
 removing 48-49

M

Main fuse
 installing 84
 removing 84

Main silencer
 glass fiber yarn filling, changing 59
 installing 59
 removing 58

Motorcycle
 cleaning 100
 raising with lift stand 45
 removing from lift stand 45

O

Overview of indicator lamps 15

Owner's manual 7

P

Protection for winter operation 101

Putting into operation
 advice on first use 26
 after storage 102
 checks and maintenance work when preparing for use .. 31

R

Rear sprocket
 checking 62

Rear wheel
 installing 79
 removing 79

Rebound damping
 fork, adjusting 42
 shock absorber, adjusting 38

Riding sag
 adjusting 41

S

Seat
 mounting 56
 removing 56

Service 6

Service schedule 35-36

Shift lever 23
 basic position, adjusting 94
 basic position, checking 94

Shock absorber
 compression damping, general information 37
 installing 55
 removing 55
 riding sag, checking 40
 spring preload of the shock absorber, adjusting 40
 static sag, checking 39

Shock absorber part number 11

Short circuit button 13

Side stand 24

Spare parts 6

Speedometer
 adjusting 17
 battery, changing 87
 clock, setting 16
 function description 15
 kilometers or miles, setting 16

Spoke tension
 checking 81

Spring preload
 fork, adjusting 43

Start number plate
 installing 54

removing 54

Starting 31

Steering

locking 24

unlocking 25

Steering head bearing

greasing 54

Steering head bearing play

adjusting 53

checking 53

Storage 102

T

Technical data

carburetor 110-117

chassis 118-119

chassis tightening torques 124

engine 105-107

engine tightening torques 108-109

fork 120-121

shock absorber 122-123

Throttle cable play

adjusting 92

checking 92

Throttle cable routing

checking 65

Throttle grip 12

Tire air pressure

checking 81

Tire condition

checking 80

Transport 6

Troubleshooting 103-104

Turn signal switch 13

Type label 10

U

Use definition 6

V

View of vehicle

right rear 9

W

Warranty 6

Work rules 6



3211688en



09/2010 Photo: Mitterbauer



KTM-Sportmotorcycle AG
5230 Mattighofen/Austria
<http://www.ktm.com>