

# SETUP INSTRUCTIONS 2012

**250 EXC-F EU**

**250 EXC-F AUS**

**250 EXC-F SIX DAYS EU**

**250 XCF-W USA**

Art. no. 3211776en



**KTM**



The work described in these setup instructions must be performed before the vehicle is delivered to the customer.

Read the setup instructions in their entirety before beginning work.

Print out the current **PDI** form found on the **KTM DEALER.NET**.

These setup instructions were written to correspond to the latest state of this series. We reserve the right to make changes in the interest of technical advancement without at the same time updating this manual.

We shall not provide a description of general workshop methods. Likewise, safety rules that apply in a workshop are not specified here. It is assumed that the work will be performed by a fully trained mechanic.

All specifications are non-binding. KTM Sportmotorcycle AG specifically reserves the right to modify or delete technical specifications, prices, colors, forms, materials, services, designs, equipment, etc., without prior notice and without specifying reasons, to adapt these to local conditions, as well as to stop production of a particular model without prior notice. KTM accepts no liability for delivery options, deviations from illustrations and descriptions, as well as misprints and other errors. The models portrayed partly contain special equipment that does not belong to the regular scope of delivery.

© 2011 KTM-Sportmotorcycle AG, Mattighofen Austria

All rights reserved

Reproduction, even in part, as well as copying of all kinds, is permitted only with the express written permission of the copyright owner.



ISO 9001(12 100 6061)

According to the international quality management standard ISO 9001, KTM uses quality assurance processes that lead to the maximum possible quality of the products.

Issued by: TÜV Management Service

REG.NO. 12 100 6061

KTM-Sportmotorcycle AG

5230 Mattighofen, Austria

## Symbols used

The meaning of specific symbols is described below.



Indicates an expected reaction (e.g. of a work step or a function).



Indicates an unexpected reaction (e.g. of a work step or a function).



Indicates a page reference (more information is provided on the specified page).



Indicates information with more details or tips.



Indicates the result of a testing step.



Denotes a voltage measurement.



Denotes a current measurement.



Denotes a resistance measurement.

## Formats used

The typographical formats used in this document are explained below.

**Proprietary name** Identifies a proprietary name.

**Name<sup>®</sup>** Identifies a protected name.

**Brand<sup>™</sup>** Identifies a trademark.

## Unpacking and setting up the vehicle



### Packaging 2

- Remove the box and the plastic packaging.

**i** **Info**

To avoid damaging the motorcycle during the setup, leave the protective film on the vehicle until you have finished.

- Remove the separate enclosure and unpack it. Check that the scope of delivery is complete on the basis of the enclosed packing list.
- Have a lift stand available.

Lift stand (54829055000)

- Carefully loosen and remove the footrest mount.

**i** **Info**

An assistant prevents the motorcycle from falling over.

- Together with an assistant, take the vehicle off the palette.
- Position the vehicle on a lift stand.
- Check the vehicle for transport damage.
- Remove the headlight mask with the headlight. (☛ p. 7)

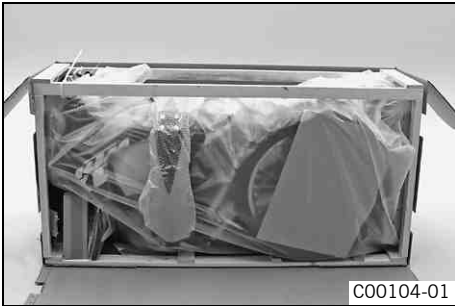

### Package 12

- Remove the box and the plastic packaging.

**i** **Info**

An assistant prevents the motorcycle from falling over.  
To avoid damaging the motorcycle during the setup, leave the protective film on the vehicle until you have finished.

- Remove the separate enclosure and unpack it. Check that the scope of delivery is complete on the basis of the enclosed packing list.

- Have a lift stand available.

Lift stand (54829055000)

- Together with an assistant, take the vehicle off the palette.
- Position the vehicle on a lift stand.
- Check the vehicle for transport damage.
- Install the shock absorber. (☛ p. 8)



### (All EXC-F models)

- Insert the indicator lamp with the blue and brown cable colors into socket 1.
- Insert the indicator lamp with the blue and violet cable colors into socket 2.
- Insert the indicator lamp with the brown/red and yellow/blue cable colors into socket 3.
- Insert indicator lamp **LED** with the white and orange cable colors into socket 4.

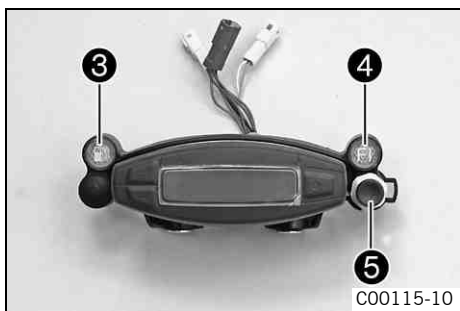

**(XCF-W)**

- Insert the indicator lamp with the brown/red and yellow/blue cable colors into socket ③.
- Insert indicator lamp **LED** with the white and orange cable colors into socket ④.
- Connect pull switch ⑤ with the yellow and white cables.

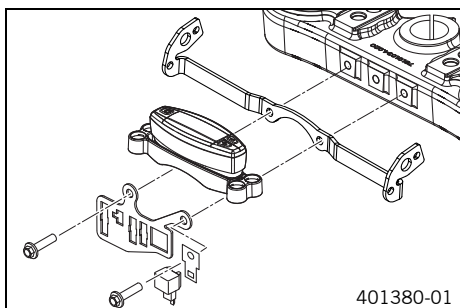

**(All EXC-F models)**

- Attach the retaining bracket for the connector, the turn signal bracket with the turn signal, and the speedometer to the upper triple clamp.

Guideline

Remaining screws, chassis	M6	10 Nm (7.4 lbf ft)
---------------------------	----	-----------------------

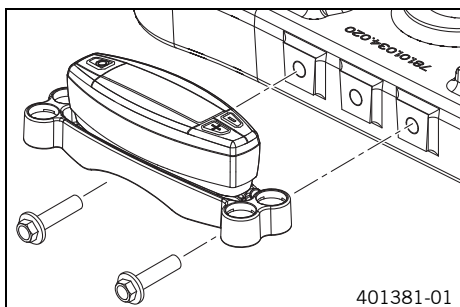

**(XCF-W)**

- Attach the speedometer to the upper triple clamp.

Guideline

Remaining screws, chassis	M6	10 Nm (7.4 lbf ft)
---------------------------	----	-----------------------

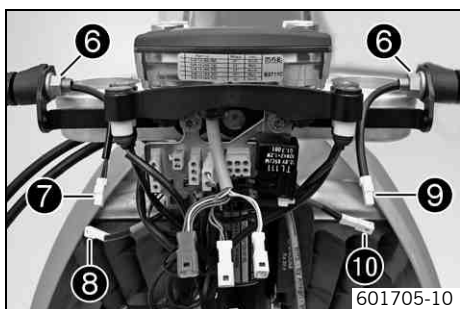

**(All EXC-F models)**

- Mount and tighten nuts ⑥ of the turn signals on both sides.
- Connect connector ⑥ of the right turn signal with connector ⑦, which is marked green.
- Connect connector ⑧ of the left turn signal with connector ⑨, which is marked red.



- Route the clutch line with the clutch master cylinder toward the front between the upper and lower triple clamps.
- Position the fork legs and tighten the screws of the triple clamp.

Guideline

Screw, top triple clamp (XCF-W, EXC-F EU, EXC-F AUS)	M8	20 Nm (14.8 lbf ft)
Screw, bottom triple clamp (XCF-W, EXC-F EU, EXC-F AUS)	M8	15 Nm (11.1 lbf ft)
Screw, top triple clamp (EXC-F SIX DAYS)	M8	17 Nm (12.5 lbf ft)
Screw, bottom triple clamp (EXC-F SIX DAYS)	M8	12 Nm (8.9 lbf ft)

**i Info**

The topmost milled groove in the fork leg must be flush with the top edge of the upper triple clamp.  
Position bleeder screws ⑩ toward the front.



C00108-10

- Position the handlebar.



**Info**

Make sure cables and wiring are positioned correctly.

- Position the handlebar clamps. Mount and tighten the screws.

Guideline

Screw, handlebar clamp	M8	20 Nm (14.8 lbf ft)
------------------------	----	------------------------



**Info**

The markings on the handlebar should be at the center of the handlebar clamps.

Keep the gap widths equal when tightening.

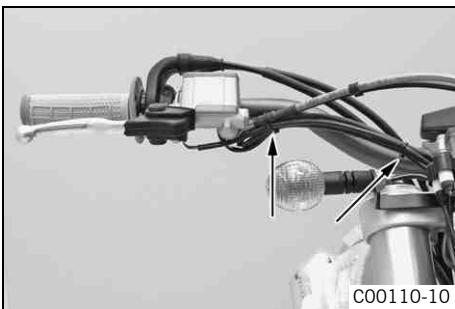

C00110-10

- Position the controls on the right half of the handlebar.



**Info**

The routing of the cables and throttle cables can be seen in the figure.

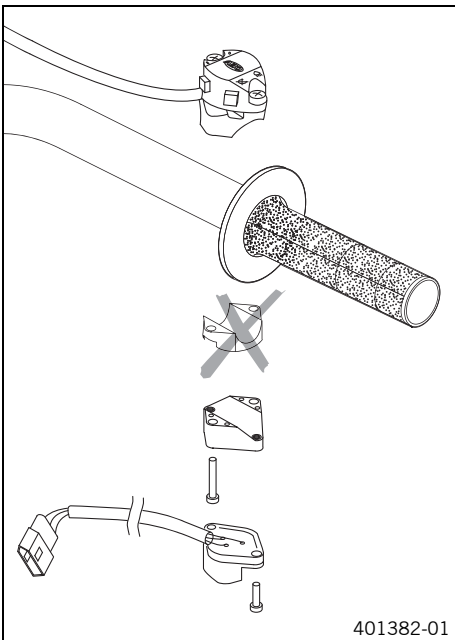

401382-01

**(All EXC-F models)**

- Mount the turn signal switch.



C00111-10

- Position the controls on the left half of the handlebar.



**Info**

The figure shows how to route the clutch line and wiring harness.

- Install the front fender. (☛ p. 9)
- Refit the headlight mask with the headlight. (☛ p. 7)
- Install the front wheel. (☛ p. 8)
- Correctly mount the fuel tank breather.



601710-01

- Secure the handlebar cushion with two cable binders.

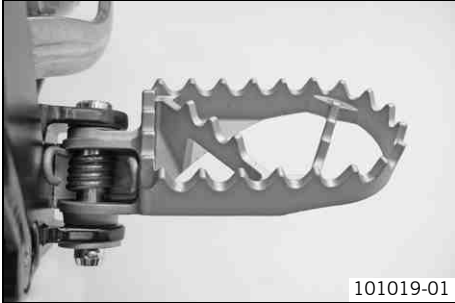

101019-01

- Mount the footrests with the springs and bolts. Secure the bolts using the washers and pins.

Pliers for footrest spring (58429083000)



601711-01

- Mount the license plate holder with the license plate lamp, turn signals, and reflector.
- Connect the electrical components.
- Connect the connector of the left turn signal with connector that is marked red.
- Connect the connector of the right turn signal with connector that is marked green.



800035-10

- 
-  **Warning**  
**Risk of injury** Battery acid and battery gases cause serious chemical burns.
    - Keep batteries out of the reach of children.
    - Wear suitable protective clothing and goggles.
    - Avoid contact with battery acid and battery gases.
    - Keep the battery away from sparks or open flames. Charge only in well-ventilated areas.
    - In the event of skin contact, rinse with large amounts of water. If battery acid gets in the eyes, rinse with water for at least 15 minutes and contact a physician.
- 

- Fill the battery.
- 

-  **Info**  
 Read the notes in the battery package.
- 

- Charge the battery. (☛ p. 10)
  - Install the battery. (☛ p. 9)
  - Unpack and mount the **KTM PowerParts** included in the delivery (optional).
- 

-  **Info**  
 Read the accompanying **KTM PowerParts** installation instructions.
- 

- Apply the label included in the delivery (optional).
- Refuel. (☛ p. 11)
- Position all controls in their exact positions on the handlebar. Tighten all screws.
- Print out the current **PDI** form found on **KTM DEALER.NET** and perform the delivery inspection.



**Removing headlight mask with headlight**

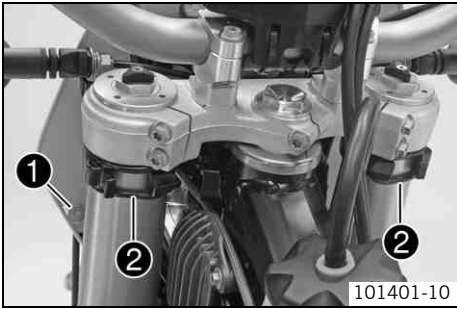

- Switch off all electrical equipment.
- Remove screw ① and take off clamp.
- Loosen the rubber band ②. Push up the headlight mask and swing it forwards.

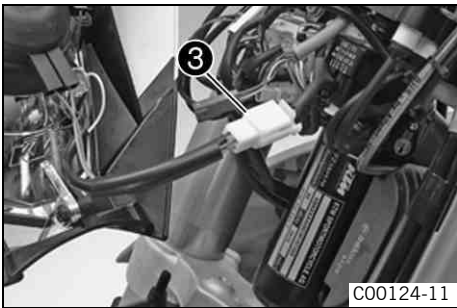

- Pull out the electric plug connector ③ and remove the headlight mask with the headlight.

**Refitting the headlight mask with the headlight**

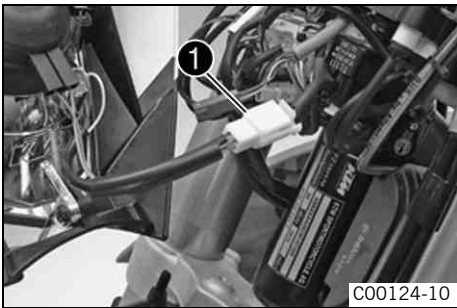

**Main work**

- Connect the electric plug connector ①.

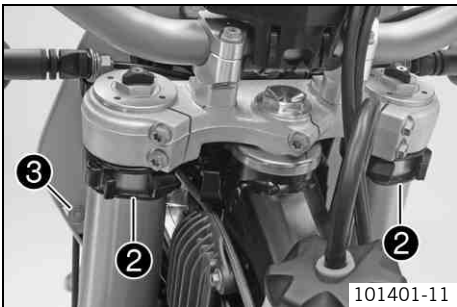

- Position the headlight mask and fix it with the rubber band ②.



**Info**

Ensure that the retaining lugs engage in the fender.

- Position the brake line and wiring harness. Put the clamp on, mount and tighten screw ③.

**Subsequent work**

- Check the headlight setting. (☛ p. 7)

**Checking the headlight setting**

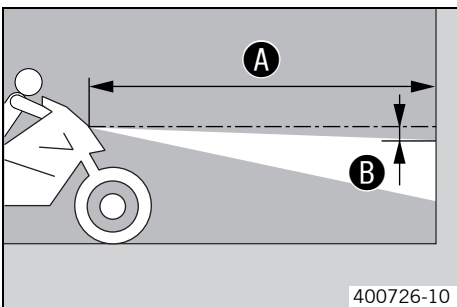

- Position the vehicle upright on a horizontal surface in front of a light wall and make a mark at the height of the center of the low beam headlight.
- Make another mark a distance ② under the first mark.

**Guideline**

Distance ②	5 cm (2 in)
------------	-------------

- Position the vehicle vertically a distance ① away from the wall.

**Guideline**

Distance ①	5 m (16 ft)
------------	-------------

- The rider now sits down on the motorcycle.
- Switch on the low beam.

- Check the headlight setting.

The boundary between light and dark must be exactly on the lower mark for a motorcycle with driver.

- » If the light-dark border does not meet specifications:
  - Adjust the headlight range.

### Installing the shock absorber

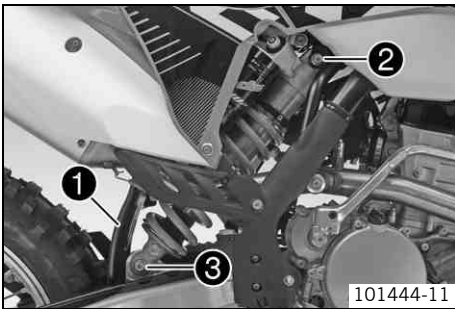

#### Main work

- Push splash protector ① to the side and position the shock absorber. Mount and tighten screw ②.

#### Guideline

Screw, top shock absorber	M12	80 Nm (59 lbf ft)	Loctite® 2701
---------------------------	-----	----------------------	---------------

- Mount and tighten screw ③.

#### Guideline

Screw, bottom shock absorber	M12	80 Nm (59 lbf ft)	Loctite® 2701
------------------------------	-----	----------------------	---------------



#### Info

The heim joint for the shock absorber at the swing arm is Teflon coated. It must not be greased with grease or with other lubricants. Lubricants dissolve the Teflon coating, thereby drastically reducing the service life.

#### Subsequent work

- Remove the motorcycle from the lift stand.

### Installing the front wheel



#### Warning

**Danger of accidents** Reduced braking efficiency due to oil or grease on the brake discs.

- Always keep the brake discs free of oil and grease, and clean them with brake cleaner when necessary.

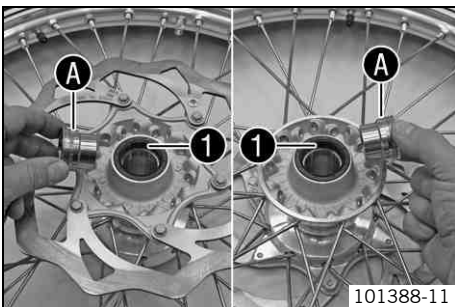

- Check the wheel bearing for damage and wear.
  - » If the wheel bearing is damaged or worn:
    - Change the wheel bearing.
- Clean and grease shaft seal rings ① and bearing surface ① of the spacers.

Long-life grease (☛ p. 15)

- Insert the spacers.

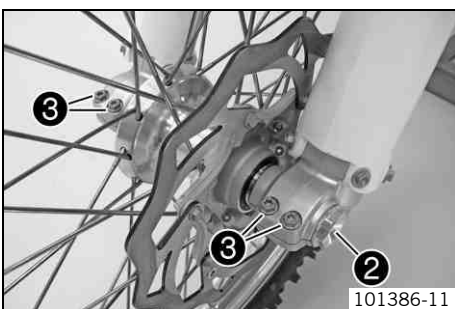

- Lift the front wheel into the fork, position it, and insert the wheel spindle.
- Mount and tighten screw ②.

#### Guideline

Screw, front wheel spindle	M24x1.5	45 Nm (33.2 lbf ft)
----------------------------	---------	------------------------

- Activate the hand brake lever multiple times until the brake linings are in contact with the brake disc.
- Remove the motorcycle from the lift stand.
- Pull the front wheel brake and push down hard on the fork several times to align the fork legs.
- Fully tighten screw ③.

#### Guideline

Screw, fork stub	M8	15 Nm (11.1 lbf ft)
------------------	----	------------------------

**Installing the front fender**

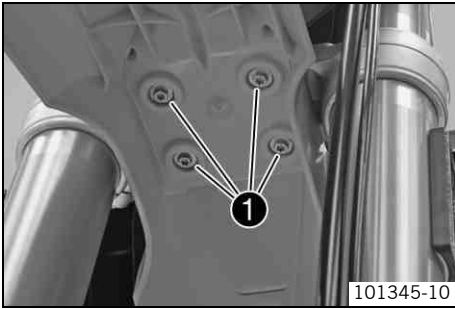

101345-10

- Ensure that the spacers are mounted in the fender.
- Position the front fender. Mount and tighten screws ❶.

Guideline

Remaining screws, chassis	M6	10 Nm (7.4 lbf ft)
---------------------------	----	--------------------

**i Info**  
Make sure the holding lugs engage in the start number plate or headlight mask.

**Removing the seat**

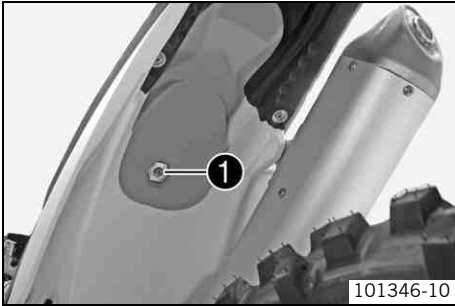

101346-10

- Remove screw ❶.
- Lift up the seat at the rear, pull it back and then remove it from above.

**Mounting the seat**

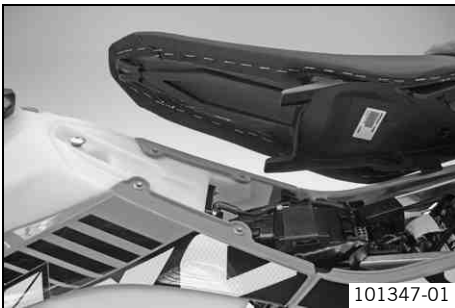

101347-01

- Hook in the front of the seat at the collar sleeve of the fuel tank, lower it at the rear and simultaneously push it forward.
- Make sure that the seat is correctly locked in.
- Mount and tighten the screw of the seat fixing.

Guideline

Remaining screws, chassis	M6	10 Nm (7.4 lbf ft)
---------------------------	----	--------------------

**Installing the battery**

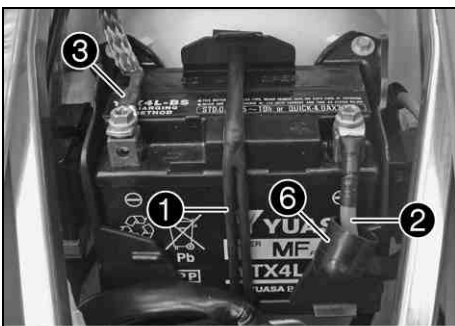

101394-10

**Main work**

- Insert battery into the battery compartment with the terminals facing to the front.

Battery (YTX4L-BS)
--------------------

- Reconnect rubber band ❶.
- Connect positive cable ❷ and negative cable ❸.

Guideline

Screw, battery terminal	M5	2.5 Nm (1.84 lbf ft)
-------------------------	----	-------------------------

**i Info**  
Contact disks ❹ must be mounted between battery terminals ❷ and cable sockets ❸ with the claws facing up.

- Slide positive terminal cover ❺ over the positive terminal.

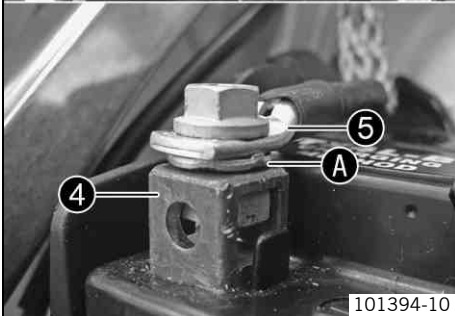

101394-10

**Subsequent work**

- Mount the seat. (☛ p. 9)

**Charging the battery**

- Warning**  
**Risk of injury** Battery acid and battery gases cause serious chemical burns.
- Keep batteries out of the reach of children.
  - Wear suitable protective clothing and goggles.
  - Avoid contact with battery acid and battery gases.
  - Keep the battery away from sparks or open flames. Charge only in well-ventilated areas.
  - In the event of skin contact, rinse with large amounts of water. If battery acid gets in the eyes, rinse with water for at least 15 minutes and contact a physician.

- Warning**  
**Environmental hazard** The battery contains elements that are harmful to the environment.
- Do not discard batteries with the household trash. Dispose of a defective battery in an environmentally compatible manner. Give the battery to your KTM dealer or to a recycling center that accepts used batteries.

- Warning**  
**Environmental hazard** Hazardous substances cause environmental damage.
- Oil, grease, filters, fuel, cleaners, brake fluid, etc., should be disposed of as stipulated in applicable regulations.

**i Info**  
 Even when there is no load on the battery, it still loses power steadily. The charge state and the type of charge are very important for the service life of the battery. Rapid recharging with a high charging current shortens the battery's service life. If the charging current, charging voltage and charging time are exceeded, electrolyte escapes through the safety valves. This reduces the battery capacity. If the battery is depleted from starting the vehicle repeatedly, the battery must be charged immediately. If the battery is left in a discharged state for an extended period, it will become over-discharged and sulfate, destroying the battery. The battery is maintenance-free, which means that the acid level does not need to be checked.

**Preliminary work**

- Switch off all power consumers and switch off the engine.
- Remove the seat. (☛ p. 9)
- Disconnect the negative cable of the battery to avoid damage to the onboard electronics.

**Main work**

- Connect the battery charger to the battery. Switch on the battery charger.

Battery charger (58429074000)
-------------------------------

You can also use the battery charger to test the open-circuit voltage and starting voltage of the battery, and to test the alternator. With this device, you cannot over-charge the battery.

**i Info**  
 Never remove lid ❶.  
 Charge the battery with at most 10% of the capacity specified on the battery housing ❷.

- Switch off the battery charger after charging. Disconnect the battery.

**Guideline**

The charge current, charge voltage, and charge time must not be exceeded.	
Charge the battery regularly when the motorcycle is not in use	3 months

**Subsequent work**

- Mount the seat. (☛ p. 9)



## Opening filler cap



### Danger

**Fire hazard** Fuel is highly flammable.

- Never refuel the vehicle near open flames or burning cigarettes, and always switch off the engine first. Be careful that no fuel is spilt, especially on hot vehicle components. Clean up spilt fuel immediately.
- Fuel in the fuel tank expands when warm and can escape if the tank is overfilled. See the notes on refueling.



### Warning

**Danger of poisoning** Fuel is poisonous and a health hazard.

- Avoid contact between fuel and skin, eyes and clothing. Do not inhale fuel vapors. If fuel gets into your eyes, rinse immediately with water and contact a doctor. Wash affected skin areas immediately with soap and water. If fuel is swallowed, contact a doctor immediately. Change clothing that has come into contact with fuel. Store fuel in a suitable canister according to regulations and keep it out of the reach of children.



### Warning

**Environmental hazard** Improper handling of fuel is a danger to the environment.

- Do not allow fuel to get into the ground water, the ground, or the sewage system.

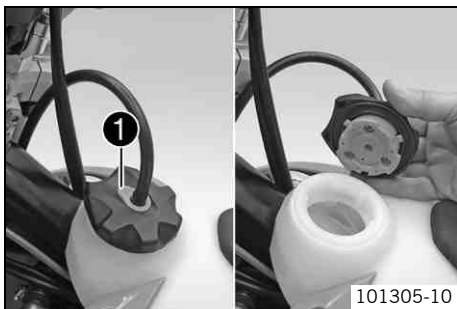

- Press release button ❶, turn filler cap counterclockwise and lift it upwards and remove.

## Closing filler cap

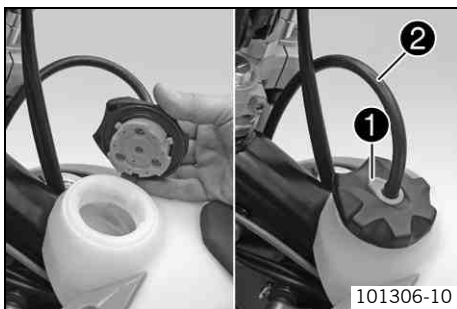

- Replace the filler cap and turn clockwise until the release button ❶ locks in place.



### Info

Route the fuel tank breather hose ❷ without kinking.

## Refueling



### Danger

**Fire hazard** Fuel is highly flammable.

- Never refuel the vehicle near open flames or burning cigarettes, and always switch off the engine first. Be careful that no fuel is spilt, especially on hot vehicle components. Clean up spilt fuel immediately.
- Fuel in the fuel tank expands when warm and can escape if the tank is overfilled. See the notes on refueling.



### Warning

**Danger of poisoning** Fuel is poisonous and a health hazard.

- Avoid contact of the fuel with skin, eyes and clothing. Do not inhale fuel vapors. If fuel gets into your eyes, rinse immediately with water and contact a doctor. Wash affected skin areas immediately with soap and water. If fuel is swallowed, contact a doctor immediately. Change clothing that has come into contact with fuel.

### Note

**Material damage** Premature clogging of the fuel filter.

- In some countries and regions, the available fuel quality and cleanliness may not be sufficient. This will result in problems with the fuel system.

- Only refuel with clean fuel that meets the specified standards.



**Warning**

**Environmental hazard** Improper handling of fuel is a danger to the environment.

- Do not allow fuel to get into the ground water, the ground, or the sewage system.

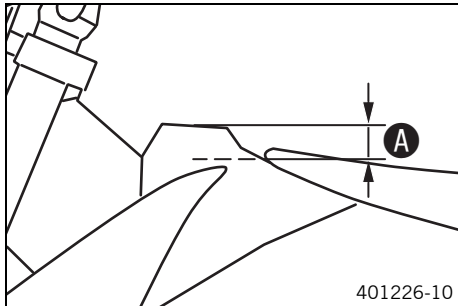

- Switch off engine.
- Open the filler cap. (☛ p. 11)
- Fill the fuel tank with fuel up to measurement **A**.

Guideline

Measurement of <b>A</b>	35 mm (1.38 in)	
Total fuel tank capacity, approx. (XCF-W)	8.5 l (2.25 US gal)	Super unleaded (ROZ 95/RON 95/PON 91) (☛ p. 14)
Total fuel tank capacity, approx. (All EXC-F models)	9 l (2.4 US gal)	Super unleaded (ROZ 95/RON 95/PON 91) (☛ p. 14)

- Close the filler cap. (☛ p. 11)

Spoke nipple, front wheel	M4.5	5... 6 Nm (3.7... 4.4 lbf ft)	–
Screw, battery terminal	M5	2.5 Nm (1.84 lbf ft)	–
Screw, intake air temperature sensor	M5	2 Nm (1.5 lbf ft)	–
Screw, shock absorber adjusting ring	M5	5 Nm (3.7 lbf ft)	–
Screw, spoiler on fuel tank (XCF-W)	M5x12	1.5 Nm (1.11 lbf ft)	–
Spoke nipple, rear wheel	M5	5... 6 Nm (3.7... 4.4 lbf ft)	–
Remaining nuts, chassis	M6	10 Nm (7.4 lbf ft)	–
Remaining screws, chassis	M6	10 Nm (7.4 lbf ft)	–
Screw, ball joint of push rod on foot brake cylinder	M6	10 Nm (7.4 lbf ft)	<b>Loctite® 243™</b>
Screw, chain sliding guard	M6	6 Nm (4.4 lbf ft)	<b>Loctite® 243™</b>
Screw, front brake disc	M6	14 Nm (10.3 lbf ft)	<b>Loctite® 243™</b>
Screw, rear brake disc	M6	14 Nm (10.3 lbf ft)	<b>Loctite® 243™</b>
Fuel connection on fuel pump	M8	10 Nm (7.4 lbf ft)	–
Nut, foot brake lever stop	M8	20 Nm (14.8 lbf ft)	–
Nut, rear sprocket screw	M8	35 Nm (25.8 lbf ft)	<b>Loctite® 2701</b>
Nut, rim lock	M8	10 Nm (7.4 lbf ft)	–
Remaining nuts, chassis	M8	25 Nm (18.4 lbf ft)	–
Remaining screws, chassis	M8	25 Nm (18.4 lbf ft)	–
Screw, bottom triple clamp (EXC-F SIX DAYS)	M8	12 Nm (8.9 lbf ft)	–
Screw, bottom triple clamp (XCF-W, EXC-F EU, EXC-F AUS)	M8	15 Nm (11.1 lbf ft)	–
Screw, chain sliding piece	M8	15 Nm (11.1 lbf ft)	–
Screw, engine brace	M8	33 Nm (24.3 lbf ft)	–
Screw, fork stub	M8	15 Nm (11.1 lbf ft)	–
Screw, front brake caliper	M8	25 Nm (18.4 lbf ft)	<b>Loctite® 243™</b>
Screw, handlebar clamp	M8	20 Nm (14.8 lbf ft)	–
Screw, side stand attachment	M8	45 Nm (33.2 lbf ft)	<b>Loctite® 2701</b>
Screw, subframe	M8	35 Nm (25.8 lbf ft)	<b>Loctite® 2701</b>
Screw, top steering stem (EXC-F SIX DAYS)	M8	17 Nm (12.5 lbf ft)	<b>Loctite® 243™</b>
Screw, top steering stem (XCF-W, EXC-F EU, EXC-F AUS)	M8	20 Nm (14.8 lbf ft)	–
Screw, top triple clamp (EXC-F SIX DAYS)	M8	17 Nm (12.5 lbf ft)	–
Screw, top triple clamp (XCF-W, EXC-F EU, EXC-F AUS)	M8	20 Nm (14.8 lbf ft)	–
Engine attachment bolt	M10	60 Nm (44.3 lbf ft)	–
Remaining nuts, chassis	M10	45 Nm (33.2 lbf ft)	–
Remaining screws, chassis	M10	45 Nm (33.2 lbf ft)	–
Screw, handlebar support	M10	40 Nm (29.5 lbf ft)	<b>Loctite® 243™</b>
Nut, fuel pump fixation	M12	15 Nm (11.1 lbf ft)	–
Screw, bottom shock absorber	M12	80 Nm (59 lbf ft)	<b>Loctite® 2701</b>
Screw, top shock absorber	M12	80 Nm (59 lbf ft)	<b>Loctite® 2701</b>
Nut, seat fixing	M12x1	20 Nm (14.8 lbf ft)	–
Nut, swingarm pivot	M16x1.5	100 Nm (73.8 lbf ft)	–
Nut, rear wheel spindle	M20x1.5	80 Nm (59 lbf ft)	–
Screw, top steering head	M20x1.5	12 Nm (8.9 lbf ft)	–
Screw-in nozzles, cooling system	M20x1.5	12 Nm (8.9 lbf ft)	<b>Loctite® 243™</b>
Screw, front wheel spindle	M24x1.5	45 Nm (33.2 lbf ft)	–

## Super unleaded (ROZ 95/RON 95/PON 91)

### According to

- DIN EN 228 (ROZ 95/RON 95/PON 91)

### Guideline

- Only use unleaded super fuel that matches or is equivalent to the specified fuel grade.
- Fuel with an ethanol content of up to 10 % (E10 fuel) is safe to use.



### Info

Do **not** use fuel containing methanol (e. g. M15, M85, M100) or more than 10 % ethanol (e. g. E15, E25, E85, E100).

---



## Long-life grease

### Guideline

- KTM recommends **Motorex®** products.

### Supplier

#### Motorex®

- **Bike Grease 2000**



3211776en



09/2011 | Photo: Mittenbauer



KTM-Sportmotorcycle AG  
5230 Mattighofen/Austria  
<http://www.ktm.com>