

SETUP INSTRUCTIONS 2012

65 SX

Art. no. 3211879en



KTM

The work described in these setup instructions must be performed before the vehicle is delivered to the customer.

Read the setup instructions in their entirety before beginning work.

Print out the current **PDI** form found on the **KTM DEALER.NET**.

These setup instructions were written to correspond to the latest state of this series. We reserve the right to make changes in the interest of technical advancement without at the same time updating this manual.

We shall not provide a description of general workshop methods. Likewise, safety rules that apply in a workshop are not specified here. It is assumed that the work will be performed by a fully trained mechanic.

All specifications are non-binding. KTM Sportmotorcycle AG specifically reserves the right to modify or delete technical specifications, prices, colors, forms, materials, services, designs, equipment, etc., without prior notice and without specifying reasons, to adapt these to local conditions, as well as to stop production of a particular model without prior notice. KTM accepts no liability for delivery options, deviations from illustrations and descriptions, as well as misprints and other errors. The models portrayed partly contain special equipment that does not belong to the regular scope of delivery.

© 2012 KTM-Sportmotorcycle AG, Mattighofen Austria

All rights reserved

Reproduction, even in part, as well as copying of all kinds, is permitted only with the express written permission of the copyright owner.



REG.NO. 12 100 6061

ISO 9001(12 100 6061)

According to the international quality management standard ISO 9001, KTM uses quality assurance processes that lead to the maximum possible quality of the products.

Issued by: TÜV Management Service

KTM-Sportmotorcycle AG
5230 Mattighofen, Austria

Symbols used

The meaning of specific symbols is described below.



Indicates an expected reaction (e.g. of a work step or a function).



Indicates an unexpected reaction (e.g. of a work step or a function).



Indicates a page reference (more information is provided on the specified page).



Indicates information with more details or tips.



Indicates the result of a testing step.



Denotes a voltage measurement.



Denotes a current measurement.



Denotes a resistance measurement.

Formats used

The typographical formats used in this document are explained below.

Proprietary name Identifies a proprietary name.

Name[®] Identifies a protected name.

Brand[™] Identifies a trademark.

Unpacking and setting up the vehicle



- Open the box.



Info

To avoid damaging the vehicle during assembly, do not remove the protective plastic from a part until just before mounting it and leave the plastic sheeting on the vehicle until work is completed.

- Remove the front wheel, fender, hand protectors, and enclosed package from the box.
- Remove the separate enclosure and unpack it. Check that the scope of delivery is complete on the basis of the enclosed packing list.
- Lift the vehicle out of the box with the help of another person.
- Raise the motorcycle with a lift stand. (☛ p. 4)
- Check the vehicle for transport damage.
- Remove screw ❶.
- Loosen screws ❷.
- Remove the wheel spindle.
- Install the front wheel. ☛ (☛ p. 4)
- Remove the protective plastic from the handlebar.

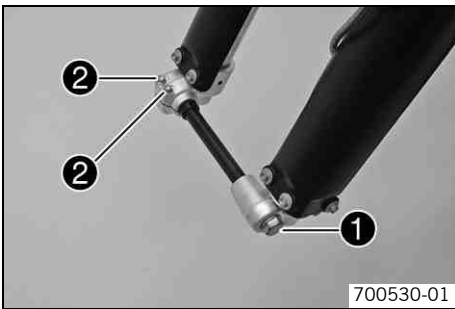

- Position the handlebar with handlebar clamps ❸.
- Mount and tighten the screws.

Guideline

Screw, handlebar clamp	M8	20 Nm (14.8 lbf ft)
------------------------	----	------------------------

- Check the handlebar position.
 - » If the handlebar position is not adjusted as the customer requires:
 - Adjust the handlebar position. ☛ (☛ p. 5)
- Install the front fender. (☛ p. 5)
- Check the wiring harness, throttle cables and brake line for free movement and correct routing.
- Check that all controls on the handlebar are in the correct location and seated firmly.
- Mount the footrests with the springs and bolts. Secure the bolts using the washers and pins.

Pliers for footrest spring (58429083000)

- Fill up with fuel. (☛ p. 6)
- Print out the current **PDI** form found on **KTM DEALER.NET** and perform the delivery inspection.

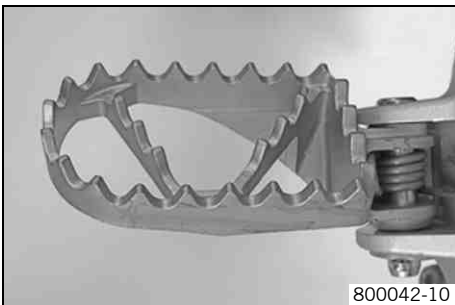
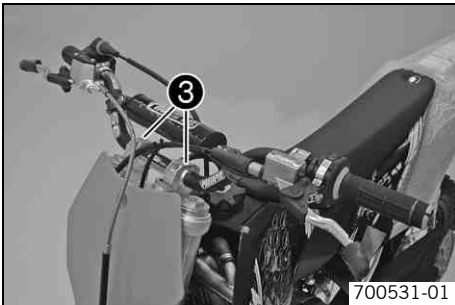

Raising the motorcycle with a lift stand

Note

Danger of damage The parked vehicle may roll away or fall over.

- Always place the vehicle on a firm and even surface.

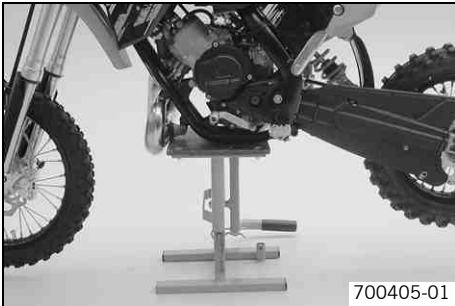

- Raise the motorcycle at the frame underneath the engine.

Lift stand (59229055000)

- ✓ The tires should no longer be in contact with the ground.
- Secure the motorcycle against falling over.

Removing the motorcycle from the lift stand

Note

Danger of damage The parked vehicle may roll away or fall over.

- Always place the vehicle on a firm and even surface.

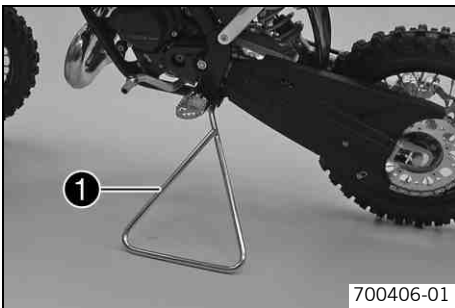

- Remove the motorcycle from the lift stand.
- Remove the lift stand.
- To park the motorcycle, insert plug-in stand ❶ into the plug-in stand bracket on the left side of the vehicle.



Info

Remove the plug-in stand before riding.

Installing the front wheel



Warning

Danger of accidents Reduced braking efficiency due to oil or grease on the brake discs.

- Always keep the brake discs free of oil and grease, and clean them with brake cleaner when necessary.

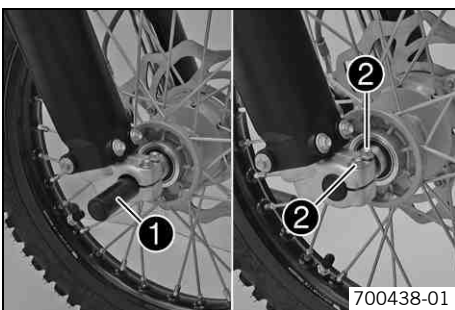

- Check the wheel bearing for damage and wear.
 - » If the wheel bearing is broken or worn:
 - Change the wheel bearing. 🛠️
- Clean and grease wheel spindle ❶.

Long-life grease (🔧 p. 9)

- Lift the front wheel into the fork, position it, and insert wheel spindle ❶.
- Tighten screws ❷.

Guideline

Screw, fork stub	M6	10 Nm (7.4 lbf ft)
------------------	----	--------------------

- Mount and tighten screw ❸.

Guideline

Screw, front wheel spindle	M10	40 Nm (29.5 lbf ft)
----------------------------	-----	---------------------

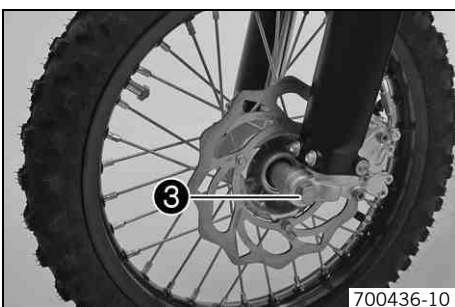

- Remove the motorcycle from the lift stand. (🔧 p. 4)

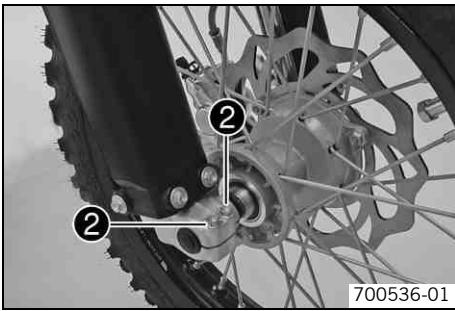

- Operate the hand brake lever several times until the brake linings are in contact with the brake disc.
- Loosen screws ②.
- Pull the front wheel brake and push down hard on the fork several times.
 - ✓ This aligns the fork legs.
- Tighten screws ②.

Guideline

Screw, fork stub	M6	10 Nm (7.4 lbf ft)
------------------	----	--------------------

Adjusting handlebar position ↩



Warning

Danger of accidents Handlebar breakage.

- If the handlebar is bent or straightened it will cause material fatigue, and the handlebar can break. Always replace handlebar.

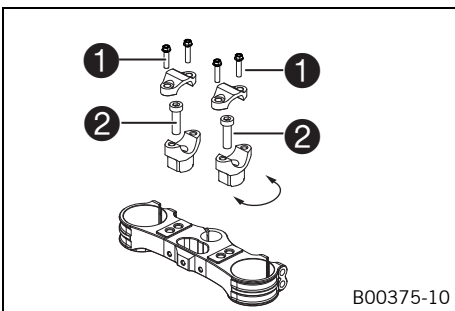

- Remove the four screws ①. Remove the handlebar clamps. Remove the handlebar and lay it to one side.



Info

Protect the motorcycle and its attachments from damage by covering them. Do not bend the cables and lines.

- Remove the two screws ②. Remove the handlebar support.
- Place the handlebar support in the required position. Mount and tighten the two screws ②.

Guideline

Screw, handlebar support	M10	40 Nm (29.5 lbf ft)	Loctite® 243™
--------------------------	-----	---------------------	----------------------

- Position the handlebar.



Info

Make sure cables and wiring are positioned correctly.

- Position the handlebar clamps. Mount and evenly tighten the four screws ①.

Guideline

Screw, handlebar clamp	M8	20 Nm (14.8 lbf ft)
------------------------	----	---------------------



Info

Make sure the gap width is even.

Installing the front fender

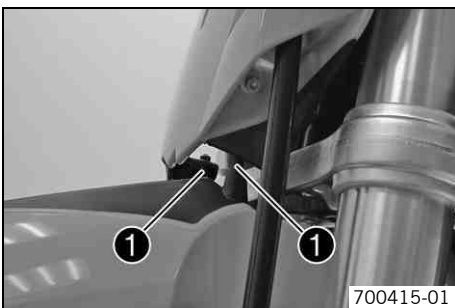

- Position the fender with holding lugs ① into the drill holes on the start number plate.

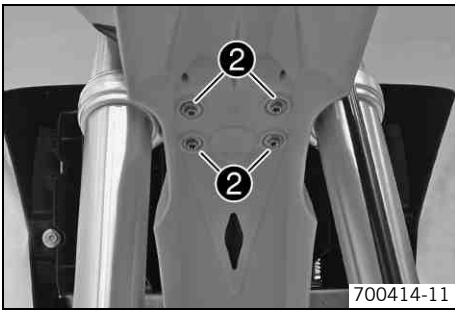

- Position the front fender. Mount and tighten screws ②.

Guideline

Remaining screws, chassis	M6	10 Nm (7.4 lbf ft)
---------------------------	----	--------------------

Refueling



Danger

Fire hazard Fuel is highly flammable.

- Never refuel the vehicle near open flames or burning cigarettes, and always switch off the engine first. Be careful that no fuel is spilt, especially on hot vehicle components. Clean up spilt fuel immediately.
- Fuel in the fuel tank expands when warm and can escape if the tank is overfilled. See the notes on refueling.



Warning

Danger of poisoning Fuel is poisonous and a health hazard.

- Avoid contact of the fuel with skin, eyes and clothing. Do not inhale fuel vapors. If fuel gets into your eyes, rinse immediately with water and contact a doctor. Wash affected skin areas immediately with soap and water. If fuel is swallowed, contact a doctor immediately. Change clothing that has come into contact with fuel.



Warning

Environmental hazard Improper handling of fuel is a danger to the environment.

- Do not allow fuel to get into the ground water, the ground, or the sewage system.

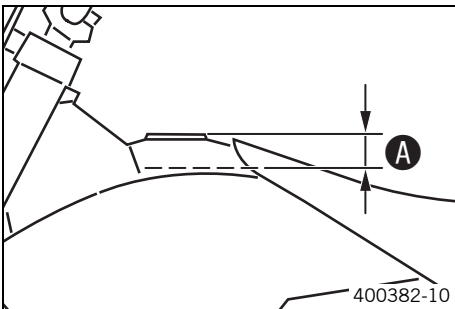

- Switch off the engine.
- Open the filler cap.
- Fill the fuel tank with fuel up to measurement ①.

Guideline

Measurement of ①	35 mm (1.38 in)	
------------------	-----------------	--

Fuel tank capacity, approx.	3.5 l (3.7 qt.)	Super unleaded gasoline, mixed with 2-stroke engine oil (1:60) (☛ p. 8)
-----------------------------	-----------------	---

2-stroke engine oil (☛ p. 8)		
------------------------------	--	--

- Close the filler cap.

Spoke nipple	M3.5	3 Nm (2.2 lbf ft)	–
Remaining nuts, chassis	M6	10 Nm (7.4 lbf ft)	–
Remaining screws, chassis	M6	10 Nm (7.4 lbf ft)	–
Screw, ball joint of push rod on foot brake cylinder	M6	10 Nm (7.4 lbf ft)	–
Screw, foot brake cylinder	M6	10 Nm (7.4 lbf ft)	–
Screw, fork stub	M6	10 Nm (7.4 lbf ft)	–
Screw, front brake disc	M6	14 Nm (10.3 lbf ft)	Loctite® 243™
Screw, rear brake disc	M6	14 Nm (10.3 lbf ft)	Loctite® 243™
Screw, throttle grip	M6	4.5 Nm (3.32 lbf ft)	–
Nut, rim lock	M8	10 Nm (7.4 lbf ft)	–
Remaining nuts, chassis	M8	25 Nm (18.4 lbf ft)	–
Remaining screws, chassis	M8	25 Nm (18.4 lbf ft)	–
Screw, bottom triple clamp	M8	15 Nm (11.1 lbf ft)	–
Screw, brake caliper	M8	20 Nm (14.8 lbf ft)	Loctite® 243™
Screw, engine bracket	M8	30 Nm (22.1 lbf ft)	–
Screw, foot brake lever	M8	35 Nm (25.8 lbf ft)	Loctite® 243™
Screw, handlebar clamp	M8	20 Nm (14.8 lbf ft)	–
Screw, rear sprocket	M8	25 Nm (18.4 lbf ft)	Loctite® 243™
Screw, tail piece	M8	35 Nm (25.8 lbf ft)	Loctite® 243™
Screw, top triple clamp	M8	20 Nm (14.8 lbf ft)	–
Remaining nuts, chassis	M10	45 Nm (33.2 lbf ft)	–
Remaining screws, chassis	M10	45 Nm (33.2 lbf ft)	–
Screw, bottom shock absorber	M10	45 Nm (33.2 lbf ft)	–
Screw, front wheel spindle	M10	40 Nm (29.5 lbf ft)	–
Screw, handlebar support	M10	40 Nm (29.5 lbf ft)	Loctite® 243™
Screw, top shock absorber	M10	45 Nm (33.2 lbf ft)	–
Nut, rear wheel spindle	M12x1	40 Nm (29.5 lbf ft)	–
Nut, swingarm pivot	M12x1	40 Nm (29.5 lbf ft)	–
Nut, steering stem	M20x1.5	10 Nm (7.4 lbf ft)	–

2-stroke engine oil

According to

- JASO FC (☛ p. 10)

Guideline

- Only use high quality 2-stroke engine oil of a well-known brand. KTM recommends **Motorex®** products.

Fully synthetic

Supplier

Motorex®

- **Cross Power 2T**

Super unleaded (ROZ 95/RON 95/PON 91)

According to

- DIN EN 228 (ROZ 95/RON 95/PON 91)

Guideline

- Only use unleaded super fuel that matches or is equivalent to the specified fuel grade.
- Fuel with an ethanol content of up to 10 % (E10 fuel) is safe to use.



Info

Do **not** use fuel containing methanol (e. g. M15, M85, M100) or more than 10 % ethanol (e. g. E15, E25, E85, E100).

Super unleaded gasoline, mixed with 2-stroke engine oil (1:60)

According to

- DIN EN 228
- JASO FC (☛ p. 10) (1:60)

Mixture ratio

1:60	2-stroke engine oil (☛ p. 8) Super unleaded (ROZ 95/RON 95/PON 91) (☛ p. 8)
------	--

Supplier

Motorex®

- **Cross Power 2T**

Long-life grease

Guideline

- KTM recommends **Motorex®** products.

Supplier

Motorex®

- **Bike Grease 2000**

JASO FC

JASO FC is a classification for a 2-stroke engine oil that was specifically developed for the extreme demands of racing. Thanks to first rate synthetic esters and specially designed additives, superb combustion is achieved even under extreme operating conditions.



3211879en



02/2012 Photo: Mitterbauer



KTM-Sportmotorcycle AG
5230 Mattighofen/Austria
<http://www.ktm.com>