

450 Rally Factory Replica

Art. no. 3211865en



KTM

DEAR KTM CUSTOMER

Congratulations on your decision to purchase a KTM motorcycle. You are now the owner of a state-of-the-art sports motorcycle that will give you enormous pleasure if you service and maintain it accordingly.

We wish you a lot of enjoyment in riding this vehicle.

Enter the serial numbers of your vehicle below.

Chassis number (☛ p. 10)	Dealer's stamp
Engine number (☛ p. 10)	
Key number (☛ p. 10)	

The Owner's Manual contained the latest information for this model at the time of going to print. Slight deviations resulting from continuing development and design can, however, not be completely excluded.

All specifications are non-binding. KTM Sportmotorcycle AG specifically reserves the right to modify or delete technical specifications, prices, colors, forms, materials, services, designs, equipment, etc., without prior notice and without specifying reasons, to adapt these to local conditions, as well as to stop production of a particular model without prior notice. KTM accepts no liability for delivery options, deviations from illustrations and descriptions, as well as misprints and other errors. The models portrayed partly contain special equipment that does not belong to the regular scope of delivery.

© 2012 KTM-Sportmotorcycle AG, Mattighofen Austria

All rights reserved

Reproduction, even in part, as well as copying of all kinds, is permitted only with the express written permission of the copyright owner.



ISO 9001(12 100 6061)

According to the international quality management standard ISO 9001, KTM uses quality assurance processes that lead to the maximum possible quality of the products.

Issued by: TÜV Management Service

REG.NO. 12 100 6061

KTM-Sportmotorcycle AG
5230 Mattighofen, Austria

TABLE OF CONTENTS









































1	MEANS OF REPRESENTATION	4	6.11.20	Table of conditions and menu activation	20
1.1	Symbols used	4	6.12	Fuel tank	20
1.2	Formats used	4	6.13	Fuel tap	20
2	SAFETY ADVICE	5	6.14	Choke	21
2.1	Use definition - intended use	5	6.15	Shift lever	21
2.2	Safety advice	5	6.16	Foot brake lever	22
2.3	Degrees of risk and symbols	5	6.17	Side stand	22
2.4	Tampering warning	5	6.18	Steering lock	22
2.5	Safe operation	6	6.19	Locking the steering	22
2.6	Protective clothing	6	6.20	Unlocking the steering	23
2.7	Work rules	6	7	PREPARING FOR USE	24
2.8	Environment	6	7.1	Advice on first use	24
2.9	Owner's Manual	6	7.2	Running in the engine	25
3	IMPORTANT NOTES	7	8	RIDING INSTRUCTIONS	26
3.1	Guarantee, warranty	7	8.1	Checks and maintenance when preparing for use	26
3.2	Operating and auxiliary substances	7	8.2	Starting	26
3.3	Spare parts, accessories	7	8.3	Starting off	27
3.4	Service	7	8.4	Shifting, riding	27
3.5	Figures	7	8.5	Braking	27
3.6	Customer service	7	8.6	Stopping, parking	28
4	VIEW OF VEHICLE	8	8.7	Transport	28
4.1	View of vehicle, front left	8	8.8	Refueling	29
4.2	View of vehicle, rear right	9	9	SERVICE SCHEDULE	30
5	SERIAL NUMBERS	10	9.1	Service schedule	30
5.1	Chassis number	10	9.2	Service work (as additional order)	31
5.2	Type label	10	10	TUNING THE CHASSIS	32
5.3	Engine number	10	10.1	Checking the basic chassis setting with the rider's weight	32
5.4	Key number	10	10.2	Compression damping of the shock absorber	32
5.5	Fork part number	10	10.3	Adjusting the high-speed compression damping of the shock absorber	32
5.6	Shock absorber part number	11	10.4	Adjusting the low-speed compression damping of the shock absorber	33
6	CONTROLS	12	10.5	Adjusting the rebound damping of the shock absorber	33
6.1	Clutch lever	12	10.6	Measuring the unloaded rear wheel sag	33
6.2	Hand brake lever	12	10.7	Checking the static sag of the shock absorber	34
6.3	Throttle grip	12	10.8	Checking the riding sag of the shock absorber	34
6.4	Kill switch	12	10.9	Adjusting the spring preload of the shock absorber 	34
6.5	Light switch	12	10.10	Adjusting the riding sag 	35
6.6	Turn signal switch	13	10.11	Checking the basic setting of the fork	35
6.7	Horn button	13	10.12	Adjusting the compression damping of the fork	36
6.8	Electric starter button	13	10.13	Adjusting the rebound damping of the fork	36
6.9	Indicator lamp overview	13	10.14	Fork offset	36
6.10	Ignition switch	13	10.15	Setting the fork offset 	37
6.11	Speedometer	14	10.16	Handlebar position	38
6.11.1	Overview	14	10.17	Adjusting the handlebar position 	38
6.11.2	Activation and test	14	11	SERVICE WORK ON THE CHASSIS	40
6.11.3	Tripmaster switch	14	11.1	Raising the motorcycle with the lift stand	40
6.11.4	Setting kilometers or miles	14	11.2	Removing the motorcycle from the lift stand	40
6.11.5	Setting the clock	15	11.3	Bleeding the fork legs	40
6.11.6	Adjusting the speedometer functions	15	11.4	Cleaning the dust boots of the fork legs	41
6.11.7	Querying lap time	16	11.5	Dismounting the front fender	41
6.11.8	Display mode SPEED (speed)	16	11.6	Installing the front fender	41
6.11.9	Display mode SPEED/H (operating hours)	16	11.7	Removing the fork legs 	42
6.11.10	Display mode SPEED/CLK (clock)	17	11.8	Removing the fork legs 	42
6.11.11	Display mode SPEED/LAP (lap time)	17	11.9	Installing the fork legs 	43
6.11.12	Display mode SPEED/ODO (odometer)	17	11.10	Removing the lower triple clamp 	43
6.11.13	Display mode SPEED/TR1 (trip master 1)	17	11.11	Installing the lower triple clamp 	44
6.11.14	Display mode SPEED/TR2 (trip master 2)	18			
6.11.15	Display mode SPEED/A1 (average speed 1)	18			
6.11.16	Display mode SPEED/A2 (average speed 2)	18			
6.11.17	Display mode SPEED/S1 (stop watch 1)	19			
6.11.18	Display mode SPEED/S2 (stop watch 2)	19			
6.11.19	Table of functions	19			

TABLE OF CONTENTS

11.12	Checking the steering head bearing play.....	46	14.4	Changing the main fuse.....	74
11.13	Adjusting the play of the steering head bearing 	46	14.5	Changing fuses of individual power consumers.....	75
11.14	Greasing the steering head bearing 	47	14.6	Checking the headlight setting	75
11.15	Removing the seat	48	14.7	Adjusting the headlight range.....	76
11.16	Mounting the seat	48	15	COOLING SYSTEM	77
11.17	Removing the air filter 	48	15.1	Cooling system	77
11.18	Installing the air filter 	49	15.2	Checking the antifreeze and coolant level.....	77
11.19	Removing the main silencer	49	15.3	Checking the coolant level	77
11.20	Installing the main silencer.....	50	15.4	Draining the coolant 	78
11.21	Changing the glass fiber yarn filling of the main silencer 	50	15.5	Refilling coolant 	78
11.22	Removing the fuel tank toward the front.....	50	16	TUNING THE ENGINE.....	80
11.23	Installing the fuel tank at the front	51	16.1	Checking the play in the throttle cable	80
11.24	Checking the chain for dirt accumulation	51	16.2	Adjusting the play in the throttle cable 	80
11.25	Cleaning the chain	52	16.3	Carburetor - idle.....	80
11.26	Checking the chain tension	52	16.4	Carburetor - adjusting the idle speed 	81
11.27	Adjusting the chain tension.....	53	16.5	Emptying the carburetor float chamber 	82
11.28	Checking the chain, rear sprocket, engine sprocket, and chain guide.....	53	16.6	Checking the basic position of the shift lever	83
11.29	Checking the frame 	55	16.7	Adjusting the basic position of the shift lever 	83
11.30	Checking the swingarm 	55	17	SERVICE WORK ON THE ENGINE	84
11.31	Checking the rubber grip	55	17.1	Checking the engine oil level.....	84
11.32	Additionally securing the rubber grip.....	56	17.2	Changing the engine oil and oil filter, cleaning the oil screen 	84
11.33	Adjusting the basic position of the clutch lever.....	56	17.3	Adding engine oil	86
11.34	Checking the fluid level of the hydraulic clutch.....	56	18	CLEANING, CARE	88
11.35	Changing the hydraulic clutch fluid 	56	18.1	Cleaning motorcycle	88
11.36	Removing the trim	57	18.2	Checks and maintenance steps for winter operation.....	89
11.37	Mounting the trim	57	19	STORAGE	90
12	BRAKE SYSTEM	59	19.1	Storage	90
12.1	Checking the free travel on the hand brake lever	59	19.2	Preparing for use after storage.....	90
12.2	Adjusting the free travel of the hand brake lever	59	20	TECHNICAL DATA.....	91
12.3	Checking the brake discs	59	20.1	Engine	91
12.4	Checking the front brake fluid level	60	20.2	Engine tightening torques	91
12.5	Adding front brake fluid 	60	20.3	Capacities	93
12.6	Checking the front brake linings	61	20.3.1	Engine oil	93
12.7	Changing the front brake linings 	61	20.3.2	Coolant	93
12.8	Checking the free travel of the foot brake lever	63	20.3.3	Fuel	93
12.9	Adjusting the free travel of the foot brake lever 	63	20.4	Chassis	93
12.10	Checking the rear brake fluid level.....	64	20.5	Electrical system.....	94
12.11	Adding rear brake fluid 	64	20.6	Tires.....	94
12.12	Checking the rear brake linings	65	20.7	Fork.....	94
12.13	Changing the rear brake linings 	65	20.8	Shock absorber.....	95
13	WHEELS, TIRES	67	20.9	Chassis tightening torques	95
13.1	Removing the front wheel 	67	20.10	Carburetor with carburetor configuration (carburetor sheets)	97
13.2	Mounting the front wheel 	67	21	WIRING DIAGRAM	98
13.3	Removing the rear wheel 	68	21.1	Page 1 of 9	98
13.4	Installing the rear wheel 	69	21.2	Page 2 of 9	100
13.5	Checking the rear hub rubber dampers 	70	21.3	Page 3 of 9	102
13.6	Checking the tire condition	70	21.4	Page 4 of 9	104
13.7	Checking the tire air pressure.....	71	21.5	Page 5 of 9	106
13.8	Checking the spoke tension.....	71	21.6	Page 6 of 9	108
14	ELECTRICAL SYSTEM	73	21.7	Page 7 of 9	110
14.1	Removing the battery 	73	21.8	Page 8 of 9	112
14.2	Installing the battery 	73	21.9	Page 9 of 9	114
14.3	Recharging the battery 	73	22	SUBSTANCES	116
			23	AUXILIARY SUBSTANCES	118
			24	STANDARDS	120
				INDEX.....	121

1.1 Symbols used

The meaning of specific symbols is described below.

-
- | | |
|--|---|
|  | Indicates an expected reaction (e.g. of a work step or a function). |
|  | Indicates an unexpected reaction (e.g. of a work step or a function). |
|  | All work marked with this symbol requires specialist knowledge and technical understanding. In the interest of your own safety, have these jobs performed by an authorized KTM workshop. There, your motorcycle will be optimally cared for by specially trained experts using the specialist tools required. |
|  | Indicates a page reference (more information is provided on the specified page). |
-

1.2 Formats used

The typographical formats used in this document are explained below.

-
- | | |
|----------------------|--|
| Specific name | Identifies a proprietary name. |
| Name® | Identifies a protected name. |
| Brand™ | Identifies a brand available on the open market. |
-

2.1 Use definition - intended use

KTM sport motorcycles are designed and built to withstand the normal stresses and strains of competitive use. The motorcycles comply with currently valid regulations and categories of the top international motorsport organizations.

- i Info**
The motorcycle is authorized for public road traffic in the homologous (reduced) version only.
In the derestricted version, the motorcycle must be used only on closed off properties remote from public road traffic.
This motorcycle is designed for use in offroad endurance competition and not primarily for use in motocross.

2.2 Safety advice

A number of safety instructions need to be followed to operate the vehicle safely. Therefore, read this manual carefully. The safety instructions are highlighted in the text and are referred to at the relevant passages.

- i Info**
The vehicle has various information and warning labels at prominent locations. Do not remove information/warning labels. If they are missing, you or others may not recognize dangers and may therefore be injured.

2.3 Degrees of risk and symbols

- ⚠ Danger**
Identifies a danger that will immediately and invariably lead to fatal or serious permanent injury if the appropriate measures are not taken.

- ⚠ Warning**
Identifies a danger that is likely to lead to fatal or serious injury if the appropriate measures are not taken.

- ⚠ Caution**
Identifies a danger that may lead to minor injuries if the appropriate measures are not taken.

Note
Identifies a danger that will lead to considerable machine and material damage if the appropriate measures are not taken.

- ☀ Warning**
Identifies a danger that will lead to environmental damage if the appropriate measures are not taken.

2.4 Tampering warning



Tampering with the noise control system is prohibited. Federal law prohibits the following acts or the causing thereof:

- 1 The removal or rendering inoperative by any person other than for purposes of maintenance, repair, or replacement, of any device or element of design incorporated into any new vehicle for the purpose of noise control prior to its sale or delivery to the ultimate purchaser or while it is in use, or
- 2 the use of the vehicle after such device or element of design has been removed or rendered inoperative by any person.

Among those acts presumed to constitute tampering are the acts listed below:

- 1 Removal or puncturing of the main silencer, baffles, header pipes or any other components which conduct exhaust gases.
- 2 Removal or puncturing of any part of the intake system.
- 3 Lack of proper maintenance.
- 4 Replacing any moving part of the vehicle, or parts of the exhaust or intake system, with parts other than those specified by the manufacturer.

2.5 Safe operation

-  **Danger**
Danger of accidents Danger arising from the rider's judgement being impaired.
- Do not operate the vehicle while under the influence of alcohol, drugs and certain medications or physically or mentally impaired.
-  **Danger**
Danger of poisoning Exhaust gases are toxic and inhaling them may result in unconsciousness and/or death.
- When running the engine, always make sure there is sufficient ventilation, and do not start or run the engine in an enclosed space without an effective exhaust extraction system.
-  **Warning**
Danger of burns Some vehicle components become very hot when the vehicle is operated.
- Do not touch hot components such as exhaust system, radiator, engine, shock absorber, and the brake system. Allow these components to cool down before starting work on them.

Only operate the vehicle when it is in perfect technical condition, in accordance with its intended use, and in a safe and environmentally compatible manner.

The vehicle should only be used by trained persons. An appropriate driver's license is needed to ride the vehicle on public roads. Have malfunctions that impair safety promptly eliminated by an authorized KTM workshop. Adhere to the information and warning labels on the vehicle.

2.6 Protective clothing

-  **Warning**
Risk of injury Missing or poor protective clothing presents an increased safety risk.
- Wear protective clothing (helmet, boots, gloves, pants and jacket with protectors) every time you ride the vehicle. Always wear protective clothing that is in good condition and meets the legal requirements.

In the interest of your own safety, KTM recommends that you only operate the vehicle while wearing protective clothing.

2.7 Work rules

Special tools are necessary for certain tasks. The tools are not contained in the vehicle but can be ordered under the number in parentheses. E.g.: bearing puller (15112017000)

During assembly, non-reusable parts (e.g. self-locking screws and nuts, seals and seal rings, O-rings, pins, lock washers) must be replaced by new parts.

In some instances, a thread locker (e.g. **Loctite**®) is required. The manufacturer instructions for use must be followed.

After disassembly, clean the parts that are to be reused and check them for damage and wear. Change damaged or worn parts.

After you complete the repair or service work, check the operating safety of the vehicle.

2.8 Environment

If you use your motorcycle responsibly, you can ensure that problems and conflicts do not occur. To protect the future of the motorcycle sport, make sure that you use your motorcycle legally, display environmental consciousness, and respect the rights of others. When disposing of used oil, other operating and auxiliary fluids, and used components, comply with the laws and regulations of the respective country.

Because motorcycles are not subject to the EU regulations governing the disposal of used vehicles, there are no legal regulations that pertain to the disposal of an end-of-life motorcycle. Your authorized KTM dealer will be glad to advise you.

2.9 Owner's Manual

It is important that you read this Owner's Manual carefully and completely before making your first trip. The Owner's Manual contains useful information and many tips on how to operate, handle, and maintain your motorcycle. Only then will you find out how to customize the vehicle ideally for your own use and how you can protect yourself from injury.

Keep the Owner's Manual in an accessible place to enable you to refer to it as needed.

If you would like to know more about the vehicle or have questions on the material you read, please contact an authorized KTM dealer. The Owner's Manual is an important component of the vehicle and should be handed over to the new owner if the vehicle is sold.

3.1 Guarantee, warranty

The work prescribed in the service schedule must be carried out by an authorized KTM workshop only and confirmed in the customer's service record and in the **KTM dealer.net**; otherwise, all warranty claims will be void. No warranty claims can be considered for damage resulting from manipulations and/or alterations to the vehicle.

Additional information on the guarantee or warranty and the procedures involved can be found in the service record.

3.2 Operating and auxiliary substances



Warning

Environmental hazard Improper handling of fuel is a danger to the environment.

- Do not allow fuel to get into the ground water, the ground, or the sewage system.

Use operating and auxiliary substances (such as fuel and lubricants) as specified in the Owner's Manual.

3.3 Spare parts, accessories

For your own safety, only use spare parts and accessory products that are approved and/or recommended by KTM and have them installed by an authorized KTM workshop. KTM accepts no liability for other products and any resulting damage or loss. Certain spare parts and accessory products are specified in parentheses in the descriptions. Your KTM dealer will be glad to advise you.

The current **KTM PowerParts** for your vehicle can be found on the KTM website.

International KTM Website: <http://www.ktm.com>

3.4 Service

A prerequisite for perfect operation and prevention of premature wear is that the service, care, and tuning work on the engine and chassis is properly carried out as described in the Owner's Manual. Incorrect adjustment and tuning of the engine and chassis can lead to damage and breakage of components.

Use of the vehicle under difficult conditions, such as on sand or on wet and muddy surfaces, can lead to considerably more rapid wear of components such as the drive train, brake system, or suspension components. For this reason, it may be necessary to inspect or replace parts before the next scheduled service.

It is imperative that you adhere to the stipulated run-in times and service intervals. If you observe these exactly, you will ensure a much longer service life for your motorcycle.

3.5 Figures

The figures contained in the manual may depict special equipment.

In the interest of clarity, some components may be shown disassembled or may not be shown at all. It is not always necessary to disassemble the component to perform the activity in question. Please follow the instructions in the text.

3.6 Customer service

Your authorized KTM dealer will be happy to answer any questions you may have on your vehicle and KTM.

A list of authorized KTM dealers can be found on the KTM website.

International KTM Website: <http://www.ktm.com>

4.1 View of vehicle, front left



1	Choke (☛ p. 21)
2	Kill switch (☛ p. 12)
2	Light switch (☛ p. 12)
2	Turn signal switch (☛ p. 13)
2	Horn button (☛ p. 13)
3	Clutch lever (☛ p. 12)
4	Steering lock (☛ p. 22)
5	Shift lever (☛ p. 21)
6	Side stand (☛ p. 22)
7	Seat release strap

4.2 View of vehicle, rear right



601286-10

- | | |
|---|----------------------------|
| 1 | Ignition switch (☛ p. 13) |
| 2 | Overview (☛ p. 14) |
| 3 | Throttle grip (☛ p. 12) |
| 4 | Fuel tap (☛ p. 20) |
| 5 | Foot brake lever (☛ p. 22) |
| 6 | Hand brake lever (☛ p. 12) |

5.1 Chassis number

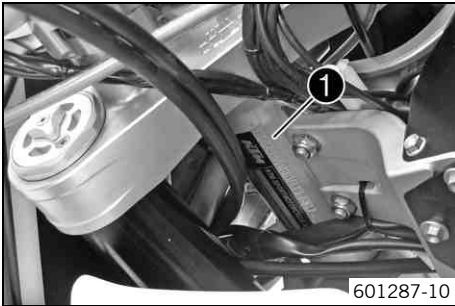

Chassis number ❶ is embossed in the steering head at the right.

5.2 Type label

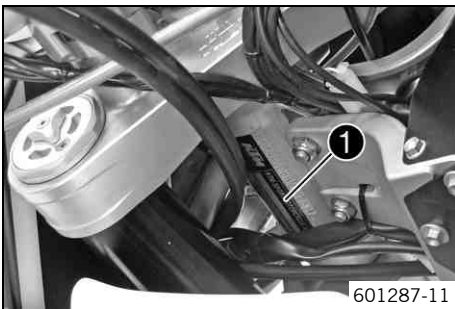

Type label ❶ is fixed to the right of the steering head.

5.3 Engine number

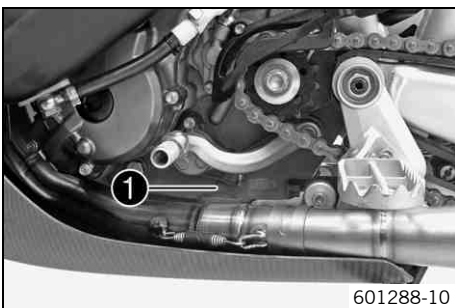

The engine number ❶ is stamped on the left side of the engine under the engine sprocket.

5.4 Key number

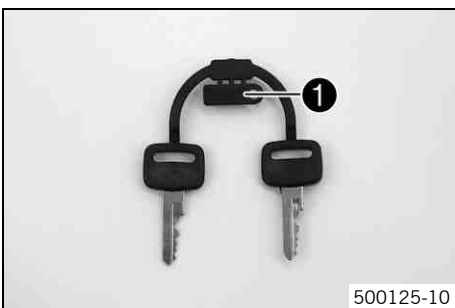

The key number ❶ for the steering lock is stamped onto the key connector.

5.5 Fork part number



The fork part number ❶ is stamped on the inner side of the fork stub.

5.6 Shock absorber part number

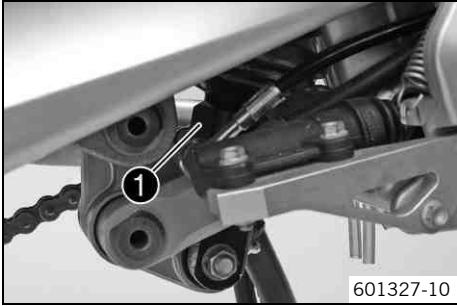

Shock absorber part number ❶ is attached to the lower part of the shock absorber at the rear, opposite to the direction of travel.

6.1 Clutch lever

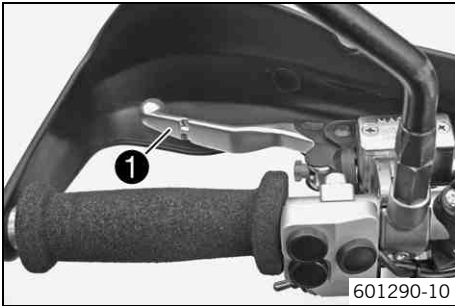

The clutch lever ❶ is fitted on the left side of the handlebar. The clutch is hydraulically operated and self-adjusting.

6.2 Hand brake lever



The hand brake lever ❶ is fitted on the right side of the handlebar. The hand brake lever operates the front brake.

6.3 Throttle grip



The throttle grip ❶ is fitted on the right side of the handlebar.

6.4 Kill switch

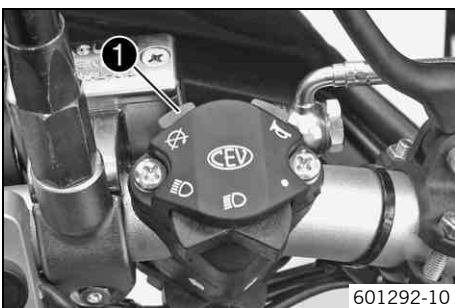

The kill switch ❶ is fitted on the left side of the handlebar.

Possible states

- Kill switch ☒ in basic position – In this position, the ignition circuit is closed, and the engine can be started.
- Kill switch ☒ pressed – In this position, the ignition circuit is interrupted, a running engine stops, and a non-running engine will not start.

6.5 Light switch

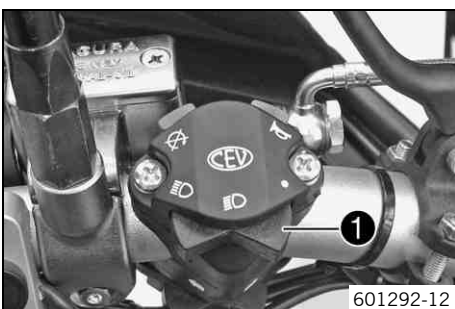

The light switch ❶ is fitted on the left side of the handlebar.

Possible states

●	Light off – Light switch is turned to the right. In this position, the light is switched off.
☞	Low beam on – Light switch is in the central position. In this position, the low beam and tail light are switched on.
☜	High beam on – Light switch is turned to the left. In this position, the high beam and the tail light are switched on.

6.6 Turn signal switch



The turn signal switch ❶ is fitted on the left side of the handlebar.

Possible states

	Turn signal off – Turn signal switch is in the central position.
←	Turn signal, left, on – Turn signal switch turned to the left.
→	Turn signal, right, on – Turn signal switch turned to the right.

6.7 Horn button



The horn button ❶ is fitted on the left side of the handlebar.

Possible states

- Horn button ⇄ in neutral position
- Horn button ⇄ pressed – The horn is operated in this position.

6.8 Electric starter button

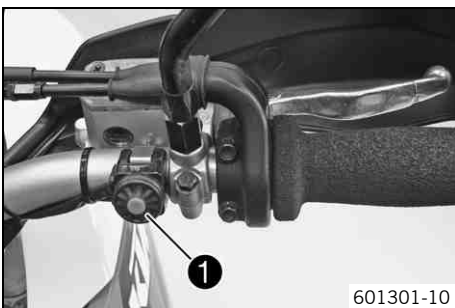

The electric starter button ❶ is fitted on the right side of the handlebar.

Possible states

- Electric starter button Ⓢ in basic position
- Electric starter button Ⓢ pressed – In this position, the electric starter is actuated.

6.9 Indicator lamp overview

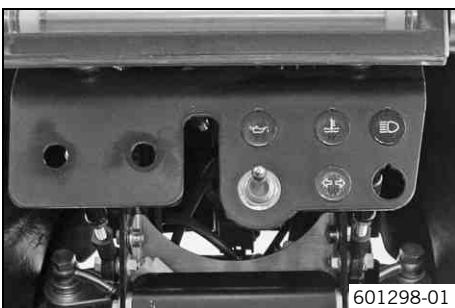

Possible states

	High beam indicator lamp lights up blue – High beam is switched on.
	Turn signal indicator light flashes green – Turn signal is switched on.
	The oil pressure warning lamp lights up red – The oil pressure is too low.
	The temperature warning lamp lights up red – The coolant temperature has reached a critical value.

6.10 Ignition switch

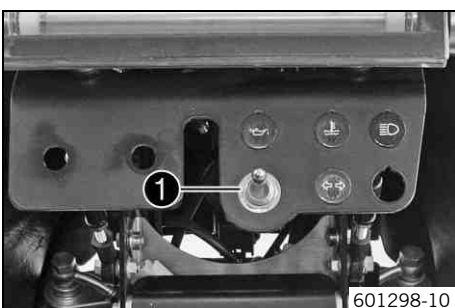

The ignition switch ❶ is located to the left of the indicator lamp on the instrument support.

Possible states

- Ignition off – Ignition switch flipped up. In this position, the ignition circuit is interrupted, a running engine stops, and a non-running engine will not start.
- Ignition on – Ignition switch flipped down. In this position, the ignition circuit is closed, and the engine can be started.

6.11 Speedometer

6.11.1 Overview

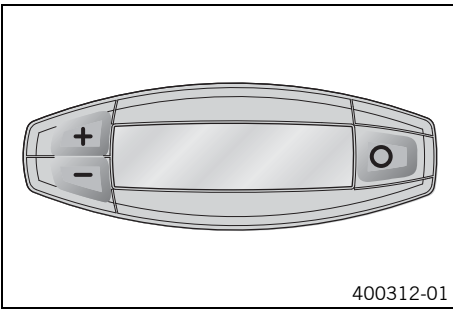

- Press the button to change the display mode or change to one of the Setup menus.
- Press the button to control different functions.
- Press the button to control different functions.

i Info
When the vehicle is delivered, only the **SPEED/H** and **SPEED/ODO** display modes are activated.

6.11.2 Activation and test

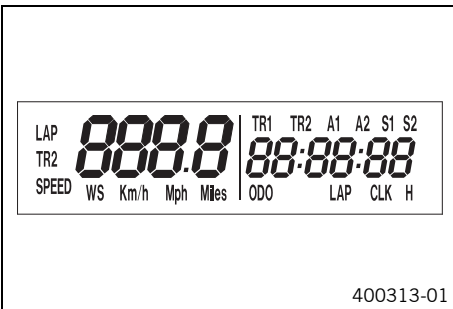

Activating the speedometer

The speedometer is activated when one of the buttons is pressed or an impulse comes from the wheel speed sensor.

Display test

To enable you to check that the display is functioning properly, all display segments light up briefly.

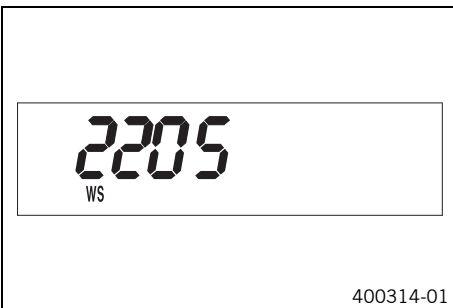

WS (wheel size)

After the display function check, the wheel size **WS** is displayed briefly.

i Info
The number 2205 equals the circumference of the 21" front wheel with standard tires.

The display then changes to the last selected mode.

6.11.3 Tripmaster switch

(Option: Tripmaster switch)

The tripmaster switch is used to control the functions of the speedometer from the handlebar.

i Info
The trip master is an optional accessory.

6.11.4 Setting kilometers or miles

i Info
If you change the unit of measure, the **ODO** value is retained and converted accordingly. The values **TR1**, **TR2**, **A1**, **A2** and **S1** are cleared when the unit of measure is changed.

Condition

The motorcycle is stationary.



- Press the button briefly and repeatedly until **H** appears at the bottom right of the display.
- Press the button for 3 - 5 seconds.
 - ✓ The Setup menu is displayed and the active functions are shown.
- Press the button repeatedly until the **Km/h/Mph** display flashes.

Adjusting Km/h

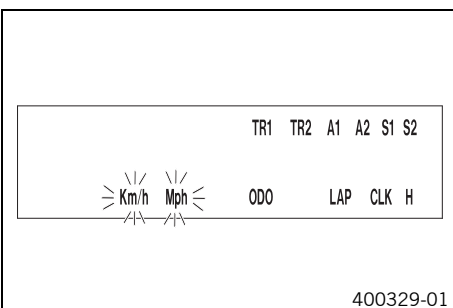
- Press the button .



Adjusting Mph

- Press the button .
- Press the button  for 3 - 5 seconds.
- ✓ The settings are stored and the Setup menu is closed.



Info





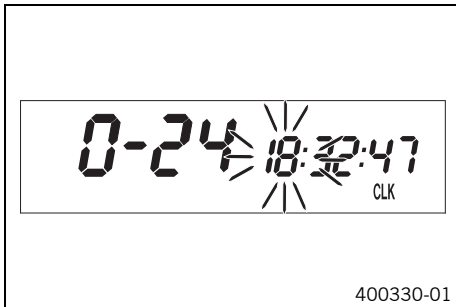

If no button is pressed for 20 seconds, or if no impulse comes from the wheel speed sensor, the settings are automatically saved and the Setup menu is closed.

6.11.5 Setting the clock



Condition

The motorcycle is stationary.

- Press the button  briefly and repeatedly until **CLK** appears at the bottom right of the display.
- Press the button  for 3 - 5 seconds.
- ✓ The hour display flashes.
- Set the hour display with the button  and/or button .
- Press the button  briefly.
- ✓ The next segment of the display flashes and can be set.
- You can set the following segments in the same way as the hours by pressing the button  and the button .



Info

The seconds can only be set to zero.

- Press the button  for 3 - 5 seconds.
- ✓ The settings are stored and the Setup menu is closed.



Info

If no button is pressed for 20 seconds, or if no impulse comes from the wheel speed sensor, the settings are automatically saved and the Setup menu is closed.

6.11.6 Adjusting the speedometer functions



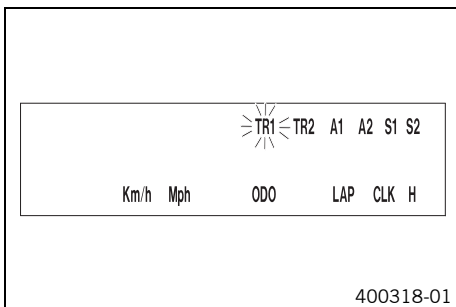

Info

When the vehicle is delivered, only the **SPEED/H** and **SPEED/ODO** display modes are activated.



Condition

The motorcycle is stationary.

- Press the button  briefly and repeatedly until **H** appears at the bottom right of the display.
- Press the button  for 3 - 5 seconds.
- ✓ The Setup menu is displayed and the activated functions are shown.
- Change to the desired function by pressing the button  briefly.
- ✓ The selected function flashes.

Activating a function

- Press the button .
- ✓ The symbol remains on the screen and the display changes to the next function.

Deactivating the function

- Press the button .
- ✓ The symbol on the screen goes out and the display changes to the next function.

- All desired functions are activated or deactivated accordingly.
- Press the button  for 3 - 5 seconds.
- ✓ The settings are stored and the Setup menu is closed.

i Info
If no button is pressed for 20 seconds, or if no impulse comes from the wheel speed sensor, the settings are automatically saved and the Setup menu is closed.

6.11.7 Querying lap time

i Info
This function can be called up only if lap times are measured.

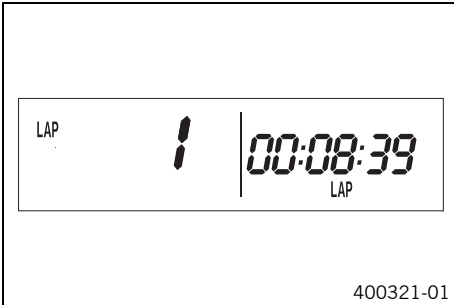

Condition

The motorcycle is stationary.

- Press the button briefly and repeatedly until **LAP** appears at the bottom right of the display.
- Press the button briefly.
- ✓ **LAP 1** appears on the left side of the display.
- Laps 1-10 can be displayed by pressing the button .
- The button has no function.
- Press the button briefly.
- ✓ Next display mode

i Info
If an impulse is received from the wheel speed sensor, the left side of the display changes back to the **SPEED** mode.

6.11.8 Display mode SPEED (speed)

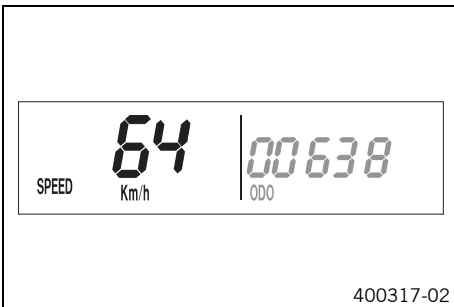

- Press the button briefly and repeatedly until **SPEED** appears on the left side of the display.

The current speed is displayed in the **SPEED** display mode.
The current speed can be displayed in **Km/h** or **Mph**.

i Info
Making the setting according to the country.
When an impulse comes from the front wheel, the left side of the speedometer display changes to the **SPEED** mode and the current speed is shown.

6.11.9 Display mode SPEED/H (operating hours)



Condition

- The motorcycle is stationary.

- Press the button briefly and repeatedly until **H** appears at the bottom right of the display.

In display mode **H**, the operating hours of the engine are displayed.
The operating hours counter stores the total traveling time.

i Info
The service hour counter is necessary for ensuring that service work is carried out at the right intervals.
If the speedometer is in **H** display mode at the start of the journey, it automatically changes to the **ODO** display mode.
The **H** display mode is suppressed during the journey.

Press the button .	No function
Press the button .	No function
Press the button for 3 - 5 seconds.	The display changes to the Setup menu of the speedometer functions.
Press the button briefly.	Next display mode

6.11.10 Display mode SPEED/CLK (clock)

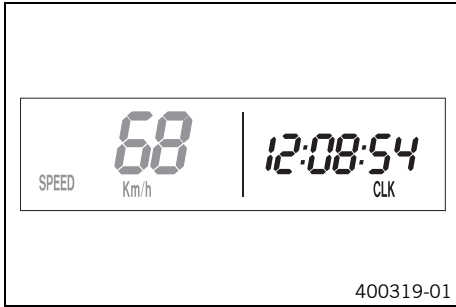

- Press the button briefly and repeatedly until **CLK** appears at the bottom right of the display.

The time is displayed in **CLK** display mode.

Press the button .	No function
Press the button .	No function
Press the button for 3 - 5 seconds.	The display changes to the Setup menu of the clock.
Press the button briefly.	Next display mode

6.11.11 Display mode SPEED/LAP (lap time)

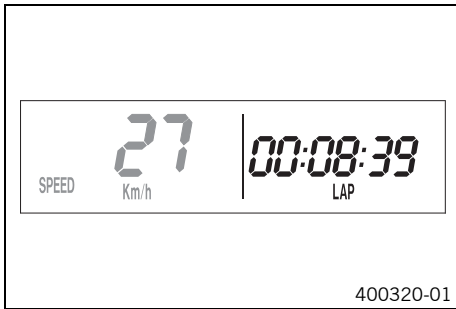

- Press the button briefly and repeatedly until **LAP** appears at the bottom right of the display.

In the **LAP** display mode, up to 10 lap times can be timed with the stop watch.

i Info
If the lap time continues after you press the button , 9 memory locations are already occupied.
Lap 10 must be timed with the button .

Press the button .	Starts or stops the clock.
Press the button .	Stops the current lap time and saves it, and the stop watch starts the next lap.
Press the button for 3 - 5 seconds.	The stop watch and the lap time are reset.
Press the button briefly.	Next display mode

6.11.12 Display mode SPEED/ODO (odometer)

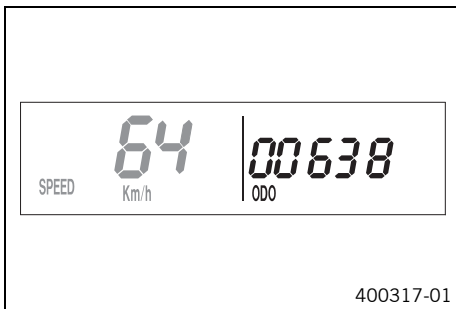

- Press the button briefly and repeatedly until **ODO** appears at the bottom right of the display.

The total distance traveled is displayed in the **ODO** display mode.

Press the button .	No function
Press the button .	No function
Press the button for 3 - 5 seconds.	–
Press the button briefly.	Next display mode

6.11.13 Display mode SPEED/TR1 (trip master 1)

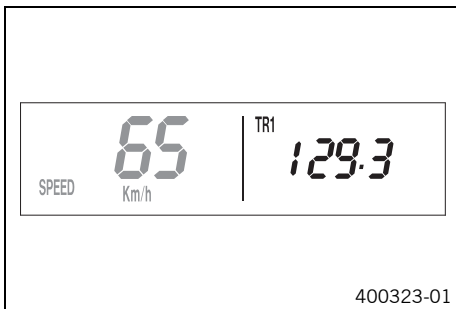

- Press the button briefly and repeatedly until **TR1** appears at the top right of the display.

TR1 (trip master 1) runs constantly and counts to 999.9.

You can use it to measure trips or the distance between refueling stops.

TR1 is coupled with **A1** (average speed 1) and **S1** (stop watch 1).

i Info
If 999.9 is exceeded, the values of **TR1**, **A1** and **S1** are automatically reset to 0.0.

Press the button .	No function
Press the button .	No function
Press the button for 3 - 5 seconds.	The TR1 , A1 and S1 displays are reset to 0.0.
Press the button briefly.	Next display mode

6.11.14 Display mode SPEED/TR2 (trip master 2)

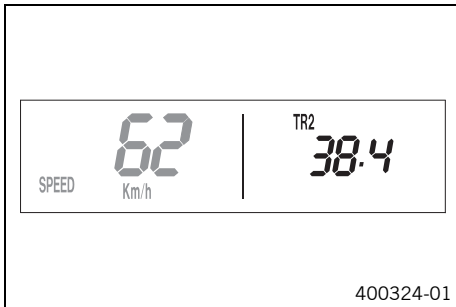

- Press the button briefly and repeatedly until **TR2** appears at the top right of the display.

TR2 (trip master 2) runs constantly and counts up to 999.9.

The displayed value can be set manually with the button and the button . This is a very practical function when riding using the road book.

i Info
The **TR2** value can also be corrected manually during the journey with the button and the button . If 999.9 is exceeded, the value of **TR2** is automatically reset to 0.0.

Press the button .	Increases value of TR2 .
Press the button .	Reduces value of TR2 .
Press the button for 3 - 5 seconds.	Deletes value of TR2 .
Press the button briefly.	Next display mode

6.11.15 Display mode SPEED/A1 (average speed 1)

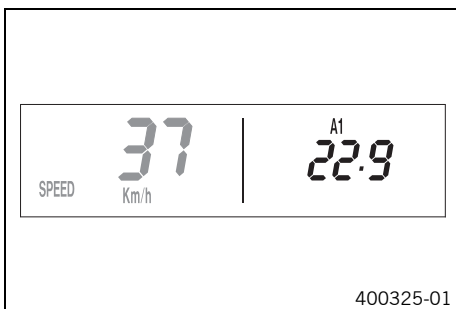

- Press the button briefly and repeatedly until **A1** appears at the top right of the display.

A1 (average speed 1) shows the average speed calculated on the basis of **TR1** (trip master 1) and **S1** (stop watch 1).

The calculation of this value is activated by the first impulse of the wheel speed sensor and ends 3 seconds after the last impulse.

Press the button .	No function
Press the button .	No function
Press the button for 3 - 5 seconds.	The TR1 , A1 and S1 displays are reset to 0.0.
Press the button briefly.	Next display mode

6.11.16 Display mode SPEED/A2 (average speed 2)

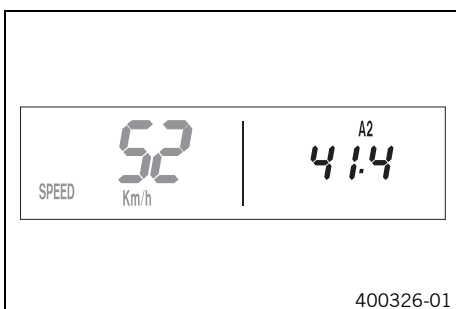

- Press the button briefly and repeatedly until **A2** appears at the top right of the display.

A2 (average speed 2) shows the average speed on the basis of the current speed if the stop watch **S2** (stop watch 2) is running.

i Info
The displayed value can differ from the actual average speed if **S2** is not stopped after the ride.

Press the button .	No function
Press the button .	No function
Press the button for 3 - 5 seconds.	–
Press the button briefly.	Next display mode

6.11.17 Display mode SPEED/S1 (stop watch 1)



– Press the button briefly and repeatedly until **S1** appears at the top right of the display.

S1 (stop watch 1) displays the journey time on the basis of **TR1** and continues when an impulse is received from the wheel speed sensor.

The calculation of this value starts with the first impulse of the wheel speed sensor and ends 3 seconds after the last impulse.

Press the button .	No function
Press the button .	No function
Press the button for 3 - 5 seconds.	Displays of TR1 , A1 and S1 are reset to 0.0.
Press the button briefly.	Next display mode

6.11.18 Display mode SPEED/S2 (stop watch 2)

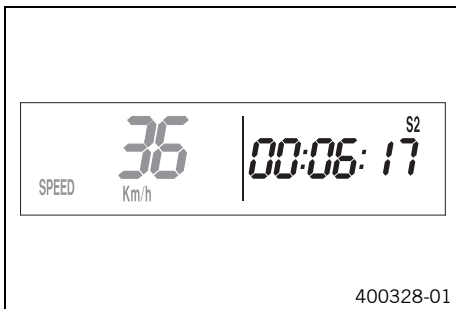

– Press the button briefly and repeatedly until **S2** appears at the top right of the display.

S2 (stop watch 2) is a manual stop watch.

If **S2** is running in the background, the **S2** display flashes in the speedometer display.

Press the button .	Starts or stops S2 .
Press the button .	No function
Press the button for 3 - 5 seconds.	Displays of S2 and A2 are reset to 0.0.
Press the button briefly.	Next display mode

6.11.19 Table of functions

Display	Press the button .	Press the button .	Press the button for 3 - 5 seconds.	Press the button briefly.
Display mode SPEED/H (operating hours)	No function	No function	The display changes to the Setup menu of the speedometer functions.	Next display mode
Display mode SPEED/CLK (clock)	No function	No function	The display changes to the Setup menu of the clock.	Next display mode
Display mode SPEED/LAP (lap time)	Starts or stops the clock.	Stops the current lap time and saves it, and the stop watch starts the next lap.	The stop watch and the lap time are reset.	Next display mode
Display mode SPEED/ODO (odometer)	No function	No function	–	Next display mode
Display mode SPEED/TR1 (trip master 1)	No function	No function	The TR1 , A1 and S1 displays are reset to 0.0.	Next display mode
Display mode SPEED/TR2 (trip master 2)	Increases value of TR2 .	Reduces value of TR2 .	Deletes value of TR2 .	Next display mode
Display mode SPEED/A1 (average speed 1)	No function	No function	The TR1 , A1 and S1 displays are reset to 0.0.	Next display mode
Display mode SPEED/A2 (average speed 2)	No function	No function	–	Next display mode
Display mode SPEED/S1 (stop watch 1)	No function	No function	Displays of TR1 , A1 and S1 are reset to 0.0.	Next display mode
Display mode SPEED/S2 (stop watch 2)	Starts or stops S2 .	No function	Displays of S2 and A2 are reset to 0.0.	Next display mode

6.11.20 Table of conditions and menu activation

Display	The motorcycle is stationary.	Menu can be activated
Display mode SPEED/H (operating hours)	•	
Display mode SPEED/CLK (clock)		•
Display mode SPEED/LAP (lap time)		•
Display mode SPEED/TR1 (trip master 1)		•
Display mode SPEED/TR2 (trip master 2)		•
Display mode SPEED/A1 (average speed 1)		•
Display mode SPEED/A2 (average speed 2)		•
Display mode SPEED/S1 (stop watch 1)		•
Display mode SPEED/S2 (stop watch 2)		•

6.12 Fuel tank

This model has three separate fuel tanks controlled by a fuel tap. Two fuel tanks are located in front of the seat and one fuel tank is located beneath the seat.

The right fuel tank is filled via filler cap ❶ and the left fuel tank is filled via filler cap ❷.

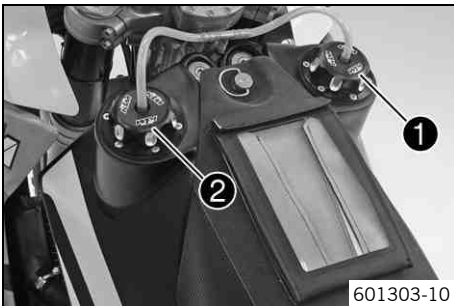

601303-10



601304-10

The rear fuel tank is filled via filler cap ❸.

6.13 Fuel tap

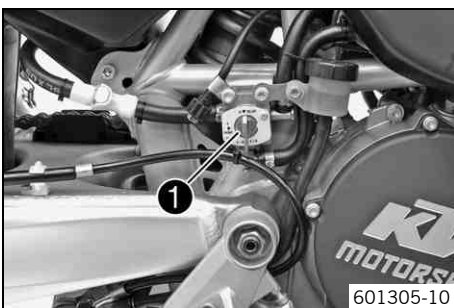

601305-10

Fuel tap ❶ is located on the right over the pivot point of the swingarm.

The fuel tap can be used to control the individual fuel tanks. The fuel tap does not have an **OFF** position since the fuel pump does not let fuel pass when the engine is stopped.

Possible states

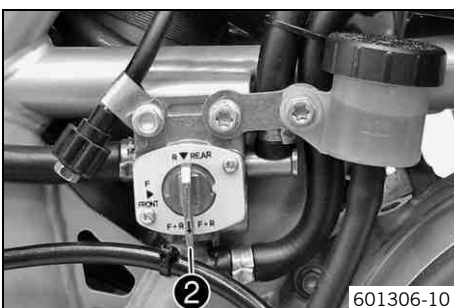

601306-10

- **F+R** – If tap handle ❷ of the fuel tap points down, fuel is taken from all three fuel tanks. All fuel tanks empty out completely.

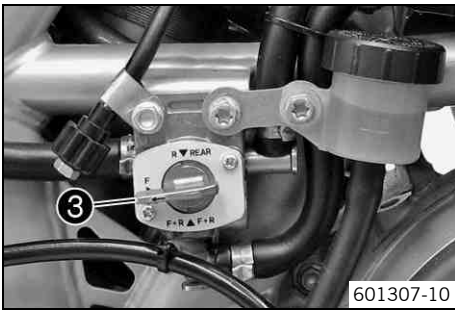

- **F FRONT** – If the tap handle ③ of the fuel tap points toward the rear, fuel is taken from the two front fuel tanks. Only the front fuel tanks empty out completely.

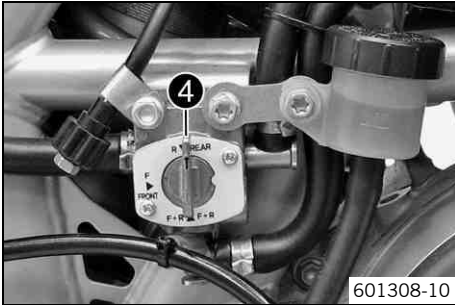

- **R REAR** – If tap handle ④ of the fuel tap points up, fuel is taken from the rear fuel tank. Only the rear fuel tank empties out completely.

6.14 Choke

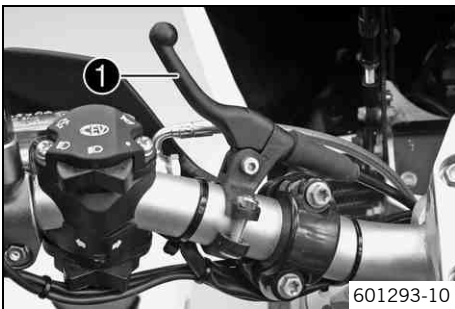

The choke lever ① is fitted on the left side of the handlebar. Activating the choke function frees an opening through which the engine can draw extra fuel. This creates a richer fuel-air mixture, as is required for a cold start.

i Info
If the engine is warm, the choke function must be deactivated.

Possible states

- Choke function activated – The choke lever is pulled to the stop.
- Choke function deactivated – The choke lever is pushed back to the stop.

6.15 Shift lever

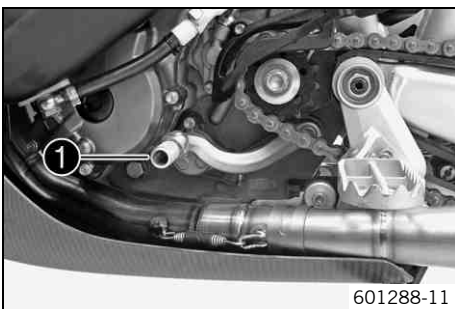

The shift lever ① is mounted on the left side of the engine.

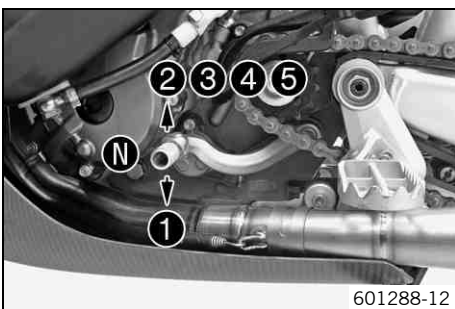

The gear positions can be seen in the photograph. The neutral or idle position is between the first and second gears.

6.16 Foot brake lever



Foot brake lever ❶ is located in front of the right footrest. The rear brake is engaged with the foot brake lever.

6.17 Side stand

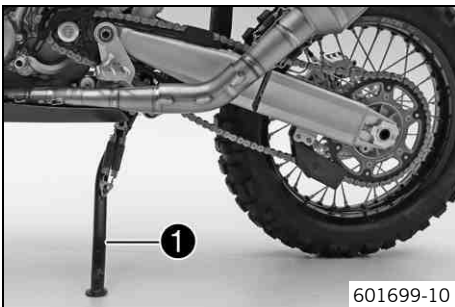

The side stand ❶ is on the left side of the vehicle.

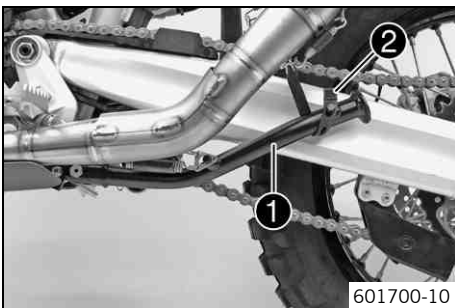

The side stand is used to park the motorcycle.

i Info
When you are riding, the side stand ❶ must be folded up and secured with the rubber band ❷.

6.18 Steering lock

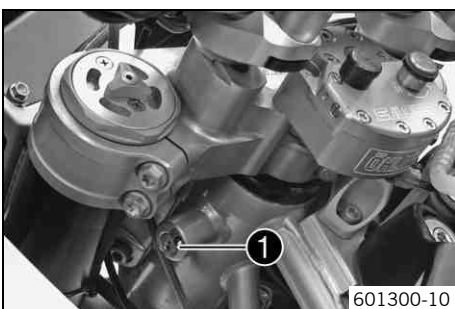

The steering lock ❶ is fitted on the left of the steering head. The steering lock is used to lock the steering. Steering, and therefore riding, is no longer possible.

6.19 Locking the steering

Note

Danger of damage The parked vehicle may roll away or fall over.

- Always place the vehicle on a firm and even surface.



- Park the vehicle.
 - Turn the handlebar as far as possible to the right.
 - Insert the key in the steering lock, turn it to the left, press it in, and turn it to the right. Remove the key.
- ✓ Steering is no longer possible.



Info

Never leave the key in the steering lock.

6.20 Unlocking the steering



- Insert the key in the steering lock, turn it to the left, pull it out, and turn it to the right. Remove the key.
- ✓ You can now steer the bike again.



Info

Never leave the key in the steering lock.

7.1 Advice on first use



Danger

Danger of accidents Danger arising from the rider's judgement being impaired.

- Do not operate the vehicle while under the influence of alcohol, drugs and certain medications or physically or mentally impaired.



Warning

Risk of injury Missing or poor protective clothing presents an increased safety risk.

- Wear protective clothing (helmet, boots, gloves, pants and jacket with protectors) every time you ride the vehicle. Always wear protective clothing that is in good condition and meets the legal requirements.



Warning

Danger of crashing Poor vehicle handling due to different tire tread patterns on front and rear wheels.

- The front and rear wheels must be fitted with tires with similar tread patterns to prevent loss of control over the vehicle.



Warning

Danger of accidents Critical riding behavior due to inappropriate riding.

- Adapt your riding speed to the road conditions and your riding ability.



Warning

Danger of accidents Accident risk caused by presence of a passenger.

- Your vehicle is not designed to carry passengers. Do not ride with a passenger.



Warning

Danger of accidents Failure of brake system.

- If the foot brake lever is not released, the brake linings drag continuously. The rear brake may fail due to overheating. Take your foot off the foot brake lever when you are not braking.



Warning

Danger of accidents Unstable riding behavior.

- Do not exceed the maximum permissible weight and axle loads.



Warning

Risk of misappropriation Usage by unauthorized persons.

- Never leave the vehicle while the engine is running. Secure the vehicle against use by unauthorized persons.



Info

When using your motorcycle, remember that others may feel disturbed by excessive noise.

- Make sure that the pre-delivery inspection work has been carried out by an authorized KTM workshop.
 - ✓ You receive a delivery certificate and the service record at vehicle handover.
- Before your first trip, read the entire operating instructions carefully.
- Get to know the controls.
- Adjust the basic position of the clutch lever. (☞ p. 56)
- Adjust the free travel of the hand brake lever. (☞ p. 59)
- Adjust the free travel of the foot brake lever. ☞ (☞ p. 63)
- Adjust the basic position of the shift lever. ☞ (☞ p. 83)
- Get used to handling the motorcycle on a suitable piece of land before making a longer trip.



Info

Offroad, you should be accompanied by another person on another machine so that you can help each other.

- Try also to ride as slowly as possible and in a standing position to get a better feeling for the vehicle.
- Do not make any offroad trips that over-stress your ability and experience.
- Hold the handlebar firmly with both hands and keep your feet on the footrests when riding.
- If you carry any baggage, make sure it is fixed firmly as close as possible to the center of the vehicle and ensure even weight distribution between the front and rear wheels.

**Info**

Motorcycles react sensitively to any changes of weight distribution.

- Do not exceed the overall maximum permitted weight and the axle loads.

Guideline

Maximum permissible overall weight	400 kg (882 lb.)
Maximum permissible front axle load	190 kg (419 lb.)
Maximum permissible rear axle load	250 kg (551 lb.)

- Run in the engine. (🔍 p. 25)

7.2 Running in the engine

- During the running-in phase, do not exceed the specified engine speed and engine performance.

Guideline

Maximum engine speed	
During the first operating hour	7,000 rpm
Maximum engine performance	
During the first 3 operating hours	≤ 75 %

- Avoid fully opening the throttle!

8.1 Checks and maintenance when preparing for use



Info

Before every trip, check the condition of the vehicle and ensure that it is safe to operate. The vehicle must be in perfect technical condition when used.

- Check the engine oil level. (☛ p. 84)
- Check the electrical system.
- Check the front brake fluid level. (☛ p. 60)
- Check the rear brake fluid level. (☛ p. 64)
- Check the front brake linings. (☛ p. 61)
- Check the rear brake linings. (☛ p. 65)
- Check that the brake system is functioning properly.
- Check the coolant level. (☛ p. 77)
- Check the chain for dirt accumulation. (☛ p. 51)
- Check the chain, rear sprocket, engine sprocket, and chain guide. (☛ p. 53)
- Check the chain tension. (☛ p. 52)
- Check the tire condition. (☛ p. 70)
- Check the tire air pressure. (☛ p. 71)
- Check the spoke tension. (☛ p. 71)
- Clean the dust boots of the fork legs. (☛ p. 41)
- Bleed the fork legs. (☛ p. 40)
- Check the air filter.
- Check the fuel filter.
- Check the settings of all controls and ensure that they can be operated smoothly.
- Check all screws, nuts, and hose clamps regularly for tightness.
- Check the fuel reserves.

8.2 Starting



Danger

Danger of poisoning Exhaust gases are toxic and inhaling them may result in unconsciousness and/or death.

- When running the engine, always make sure there is sufficient ventilation, and do not start or run the engine in an enclosed space without an effective exhaust extraction system.

Note

Engine failure High engine speeds in cold engines have a negative effect on the service life of the engine.

- Always warm up the engine at low engine speeds.



Info

If the motorcycle is unwilling to start, the cause may be old fuel in the float chamber. The flammable elements of the fuel evaporate after a long time of standing.

If the float chamber is filled with fresh fuel, the engine starts immediately.

Press the starter for a maximum of 5 seconds. Wait for at least 5 seconds before trying again.

Engine has been out of use for more than 1 week

- Empty the carburetor float chamber. ☛ (☛ p. 82)
- Raise the motorcycle off of the stand and secure the stand with rubber band ❶.
- Shift gear to neutral.
- Flip the ignition switch down.

The engine is cold

- Pull the choke lever to the stop.



600012-11

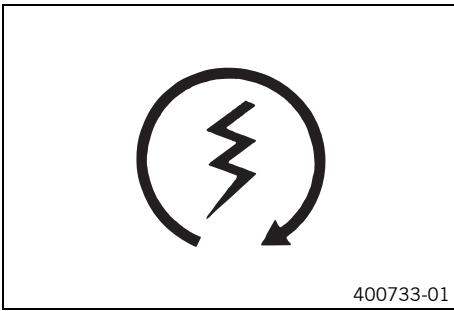

- Press the electric starter button.

**Info**

Do not rev up.

8.3 Starting off

**Info**

Switch on the light before riding the motorcycle. You will then be seen earlier by other motorists. When you are riding, the side stand must be folded up and secured with the rubber band.

- Pull the clutch lever, engage 1st gear, release the clutch lever slowly and simultaneously open the throttle carefully.

8.4 Shifting, riding

**Warning**

Danger of accidents If you change down at high engine speed, the rear wheel can lock up.

- Do not change into a low gear at high engine speed. The engine races and the rear wheel can lock up.

**Info**

If you hear unusual noises while riding, stop immediately, switch off the engine, and contact an authorized KTM workshop. First gear is used for starting off or for steep inclines.

- When conditions allow (incline, road situation, etc.), you can shift into a higher gear. To do so, release the throttle while simultaneously pulling the clutch lever, shift into the next gear, release the clutch, and open the throttle.
- If the choke function was activated, deactivate it after the engine has warmed up.
- After reaching maximum speed by fully opening the throttle grip, turn the throttle back so it is $\frac{3}{4}$ open. This will barely reduce the speed but fuel consumption will be considerably lower.
- Always open the throttle only as much as the engine can handle – abrupt throttle opening increases fuel consumption.
- To shift down, brake and close the throttle at the same time.
- Pull the clutch lever and shift into a lower gear, release the clutch lever slowly and open the throttle or shift again.
- Switch off the engine if you expect to be standing for a long time.

Guideline

≥ 2 min

- Avoid frequent and longer slipping of the clutch. This heats the engine oil, the engine, and the cooling system.
- Ride with a lower engine speed instead of with a high engine speed and a slipping clutch.

8.5 Braking

**Warning**

Danger of accidents If you brake too hard, the wheels can lock.

- Adapt your braking to the traffic situation and the road conditions.

**Warning**

Danger of accidents Reduced braking efficiency caused by spongy pressure point of front or rear brake.

- Check the brake system and do not continue riding. (Your authorized KTM workshop will be glad to help.)

**Warning**

Danger of accidents Reduced braking efficiency due to a wet or dirty brake system.

- Clean or dry a dirty or wet brake system by riding and braking gently.

- On sandy, wet or slippery surfaces, use the rear brake.
- Braking should always be completed before you go into a bend. Change down to a lower gear appropriate to your road speed.
- On long downhill stretches, use the braking effect of the engine. To do so, shift back one or two gears, but do not overrev the engine. You will need to apply the brakes far less often and the brake system will not overheat.

8.6 Stopping, parking



Warning

Risk of misappropriation Usage by unauthorized persons.

- Never leave the vehicle while the engine is running. Secure the vehicle against use by unauthorized persons.



Warning

Danger of burns Some vehicle components become very hot when the vehicle is operated.

- Do not touch hot components such as exhaust system, radiator, engine, shock absorber, and the brake system. Allow these components to cool down before starting work on them.

Note

Danger of damage The parked vehicle may roll away or fall over.

- Always place the vehicle on a firm and even surface.

Note

Fire hazard Some vehicle components become very hot when the vehicle is operated.

- Do not park the vehicle near flammable or explosive substances. Do not place objects on the vehicle while it is still warm from being run. Always let the vehicle cool first.

Note

Material damage Damage and destruction of components by excessive load.

- The side stand is designed for the weight of the motorcycle only. Do not sit on the motorcycle when it is supported by the side stand only. The side stand and/or the frame could be damaged and the motorcycle could fall over.

- Brake the motorcycle.
- Shift gear to neutral.
- With the engine idling, flip the ignition switch up until the engine stops.
- Park the motorcycle on firm ground.

8.7 Transport

Note

Danger of damage The parked vehicle may roll away or fall over.

- Always place the vehicle on a firm and even surface.

Note

Fire hazard Some vehicle components become very hot when the vehicle is operated.

- Do not park the vehicle near flammable or explosive substances. Do not place objects on the vehicle while it is still warm from being run. Always let the vehicle cool first.

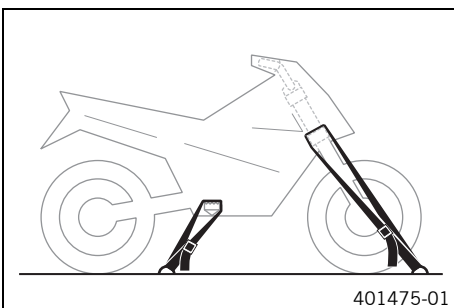

- Switch off the engine.
- Use tension belts or other suitable devices to secure the motorcycle against accidents or falling over.

8.8 Refueling



Danger

Fire hazard Fuel is highly flammable.

- Never refuel the vehicle near open flames or burning cigarettes, and always switch off the engine first. Be careful that no fuel is spilt, especially on hot vehicle components. Clean up spilt fuel immediately.
- Fuel in the fuel tank expands when warm and can escape if the tank is overfilled. See the notes on refueling.



Warning

Danger of poisoning Fuel is poisonous and a health hazard.

- Avoid contact of the fuel with skin, eyes and clothing. Do not inhale fuel vapors. If fuel gets into your eyes, rinse immediately with water and contact a doctor. Wash affected skin areas immediately with soap and water. If fuel is swallowed, contact a doctor immediately. Change clothing that has come into contact with fuel.



Warning

Environmental hazard Improper handling of fuel is a danger to the environment.

- Do not allow fuel to get into the ground water, the ground, or the sewage system.

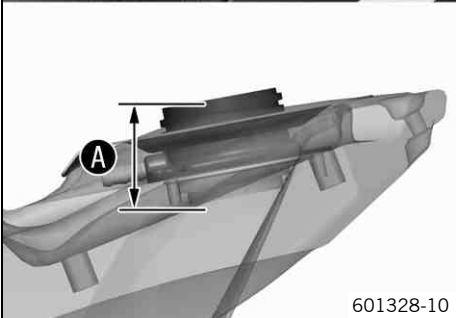
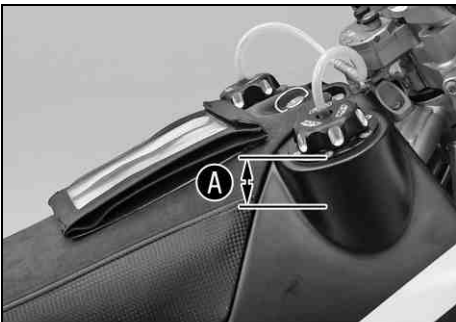

601328-10

- Switch off the engine.
- Unscrew the filler cap.
- Fill the fuel tank with fuel up to measurement **A**.

Guideline

Measurement of A	45 mm (1.77 in)
-------------------------	-----------------

Fuel tank capacity		
Fuel tank half, front left, approx.	9.0 l (2.38 US gal)	Super unleaded (ROZ 95/RON 95/PON 91) (☛ p. 117)
Fuel tank half, front right, approx.	9.0 l (2.38 US gal)	Super unleaded (ROZ 95/RON 95/PON 91) (☛ p. 117)
Rear fuel tank, approx.	18.0 l (4.76 US gal)	Super unleaded (ROZ 95/RON 95/PON 91) (☛ p. 117)
Total fuel capacity, approx.	36.0 l (9.51 US gal)	Super unleaded (ROZ 95/RON 95/PON 91) (☛ p. 117)

- Replace the filler cap and turn clockwise until the fuel tank is tightly closed.



Info

Run the fuel tank breather hoses without kinks.

9.1 Service schedule

	S1N	S10A	S20A	S30A
Check that the electrical equipment is functioning properly.	•	•	•	•
Check and charge the battery. 🛠️		•	•	•
Change the engine oil and oil filter, clean the oil screen. 🛠️ (📖 p. 84)	•	•	•	•
Check the front brake linings. (📖 p. 61)		•	•	•
Check the rear brake linings. (📖 p. 65)		•	•	•
Check the brake discs. (📖 p. 59)		•	•	•
Check the brake lines for damage and leakage.		•	•	•
Check the rear brake fluid level. (📖 p. 64)		•	•	•
Check the free travel of the foot brake lever. (📖 p. 63)		•	•	•
Check the frame and swingarm. 🛠️		•	•	•
Check the swingarm bearing. 🛠️			•	
Check the heim joints at the top and bottom of the shock absorber. 🛠️		•	•	•
Check the shock absorber linkage. 🛠️		•	•	•
Conduct a minor fork service. 🛠️		•	•	•
Conduct a major fork service. 🛠️				•
Check the tire condition. (📖 p. 70)	•	•	•	•
Check the tire air pressure. (📖 p. 71)	•	•	•	•
Check the wheel bearing for play. 🛠️		•	•	•
Check the wheel hubs. 🛠️		•	•	•
Check the rim run-out. 🛠️	•	•	•	•
Check the spoke tension. (📖 p. 71)	•	•	•	•
Check the chain, rear sprocket, engine sprocket, and chain guide. (📖 p. 53)		•	•	•
Check the chain tension. (📖 p. 52)	•	•	•	•
Lubricate all moving parts (e.g., hand lever, chain, ...) and check for smooth operation. 🛠️		•	•	•
Check the fluid level of the hydraulic clutch. (📖 p. 56)		•	•	•
Check the front brake fluid level. (📖 p. 60)		•	•	•
Check the free travel on the hand brake lever. (📖 p. 59)		•	•	•
Check the steering head bearing play. (📖 p. 46)	•	•	•	•
Check the valve clearance. 🛠️		•	•	•
Check the clutch. 🛠️		•	•	•
Change the absorbing elements in the outer clutch hub. 🛠️				•
Check all hoses (e.g. fuel, cooling, bleeder, drainage, etc.) and sleeves for cracking, leaks, and incorrect routing. 🛠️	•	•	•	•
Check the antifreeze and coolant level. (📖 p. 77)	•	•	•	•
Check the cables for damage and routing without sharp bends. 🛠️		•	•	•
Check that the cables are undamaged, routed without sharp bends and set correctly.	•	•	•	•
Clean the air filter and air filter box.	•	•	•	•
Change the fuel filter. 🛠️		•	•	•
Change the glass fiber yarn filling of the main silencer. 🛠️ (📖 p. 50)		•	•	•
Check the screws and nuts for tightness. 🛠️	•	•	•	•
Check the headlight setting. (📖 p. 75)	•	•	•	•
Check the idle. 🛠️	•	•	•	•
Final check: Check the vehicle for safe operation and take a test ride.	•	•	•	•
Make the service entry in KTM DEALER.NET and in the service record. 🛠️	•	•	•	•

S1N: Once after 1 operating hour

S10A: Every 10 operating hours/after every race

S20A: Every 20 operating hours

S30A: Every 30 operating hours

9.2 Service work (as additional order)

	S20N	S20A	S40A	S80A	J1A
Change the front brake fluid. 🛠️			•	•	•
Change the rear brake fluid. 🛠️			•	•	•
Change the hydraulic clutch fluid. 🛠️ (🔧 p. 56)				•	•
Grease the steering head bearing. 🛠️ (🔧 p. 47)			•	•	•
Check/set the carburetor components.			•	•	•
Service the shock absorber. 🛠️	•		•	•	
Change the spark plug and spark plug connector. 🛠️			•	•	
Change the piston. 🛠️			•	•	
Change the piston. (in difficult operating conditions) 🛠️		•	•	•	
Check/measure the cylinder. 🛠️			•	•	
Check the cylinder head. 🛠️			•	•	
Change the valves, valve springs and valve spring seats. 🛠️			•	•	
Check the camshaft and cam lever. 🛠️			•	•	
Change the connecting rod, conrod bearing and crank pin. 🛠️			•	•	
Change the crankshaft bearing. 🛠️			•	•	
Check the transmission and shift mechanism. 🛠️			•	•	
Check the oil pressure. 🛠️		•	•	•	
Check the oil pressure regulator valve. 🛠️			•	•	
Check the oil pumps and lubrication system. 🛠️			•	•	
Check the timing assembly. 🛠️			•	•	
Change all engine bearings. 🛠️				•	

S20N: Once after 20 operating hours

S20A: Every 20 operating hours

S40A: Every 40 operating hours

S80A: Every 80 operating hours

J1A: Annually

10.1 Checking the basic chassis setting with the rider's weight

i Info
When adjusting the basic chassis setting, first adjust the shock absorber and then the fork.

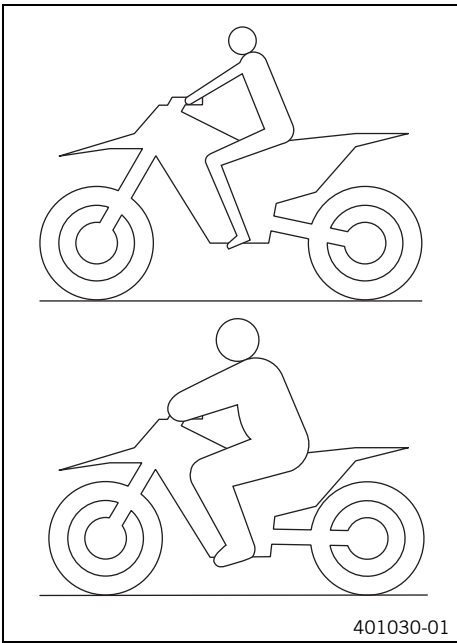

- For optimal motorcycle riding characteristics and to avoid damage to forks, shock absorbers, swingarm and frame, the basic settings of the suspension components must match the rider's weight.
- As delivered, KTM offroad motorcycles are adjusted for a standard rider weight (with full protective clothing).

Guideline

Standard rider weight	80 kg (176 lb.)
-----------------------	-----------------

- If the rider's weight is above or below this range, the basic setting of the suspension components must be adjusted accordingly.
- Small weight differences can be compensated by adjusting the spring preload, but in the case of large weight differences, the springs must be replaced.

10.2 Compression damping of the shock absorber

The compression damping of the shock absorber is divided into two ranges: high-speed and low-speed. High-speed and low-speed refer to the compression speed of the rear wheel suspension and not to the vehicle speed. The high-speed setting, for example, has an effect on the landing after a jump: the rear wheel suspension compresses more quickly. The low-speed setting, for example, has an effect when riding over long ground swells: the rear wheel suspension compresses more slowly. These two ranges can be adjusted separately, although the transition between high-speed and low-speed is gradual. Thus, changes in the high-speed range affect the compression damping in the low-speed range and vice versa.

10.3 Adjusting the high-speed compression damping of the shock absorber

⚠ Caution
Danger of accidents Disassembly of pressurized parts can lead to injury.

- The shock absorber is filled with high density nitrogen. Adhere to the description provided. (Your authorized KTM workshop will be glad to help.)

i Info
The high-speed setting can be seen during the fast compression of the shock absorber.

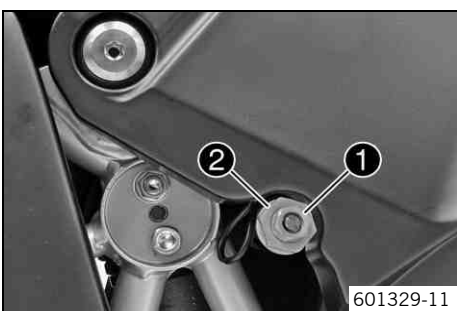

- Turn adjusting screw ❶ all the way clockwise with a socket wrench.

i Info
Do not loosen nut ❷!

- Turn back counterclockwise by the number of turns corresponding to the shock absorber type.

Guideline

Compression damping, high-speed	
Standard	1.5 turns

i Info
Turn clockwise to increase damping; turn counterclockwise to reduce damping.

10.4 Adjusting the low-speed compression damping of the shock absorber

Caution
Danger of accidents Disassembly of pressurized parts can lead to injury.

- The shock absorber is filled with high density nitrogen. Adhere to the description provided. (Your authorized KTM workshop will be glad to help.)

Info
 The low-speed setting can be seen during the slow to normal compression of the shock absorber.

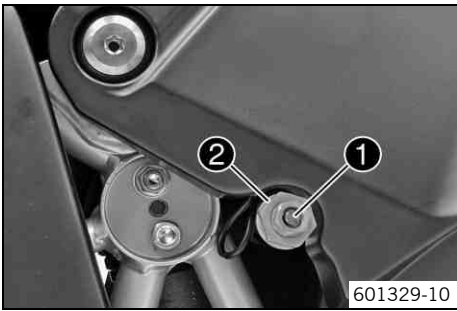

- Turn adjusting screw ❶ clockwise with a screwdriver up to the last perceptible click.

Info
 Do not loosen nut ❷!

- Turn back counterclockwise by the number of clicks corresponding to the shock absorber type.

Guideline

Compression damping, low-speed	
Standard	10 clicks

Info
 Turn clockwise to increase damping; turn counterclockwise to reduce damping.

10.5 Adjusting the rebound damping of the shock absorber

Caution
Danger of accidents Disassembly of pressurized parts can lead to injury.

- The shock absorber is filled with high density nitrogen. Adhere to the description provided. (Your authorized KTM workshop will be glad to help.)

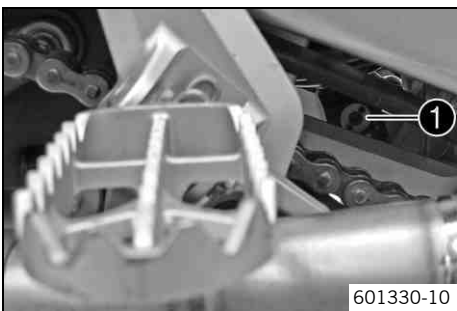

- Turn adjusting screw ❶ clockwise up to the last perceptible click.
- Turn back counterclockwise by the number of clicks corresponding to the shock absorber type.

Guideline

Rebound damping	
Standard	18 clicks

Info
 Turn clockwise to increase damping; turn counterclockwise to reduce damping.

10.6 Measuring the unloaded rear wheel sag

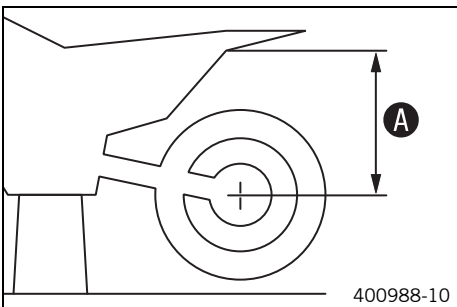

Preparatory work

- Raise the motorcycle with the lift stand. (☛ p. 40)

Main work

- Measure the vertical distance between the rear axle and a fixed point such as a marking on the side cover.
- Note down the value as dimension ❶.

Finishing work

- Remove the motorcycle from the lift stand. (☛ p. 40)

10.7 Checking the static sag of the shock absorber

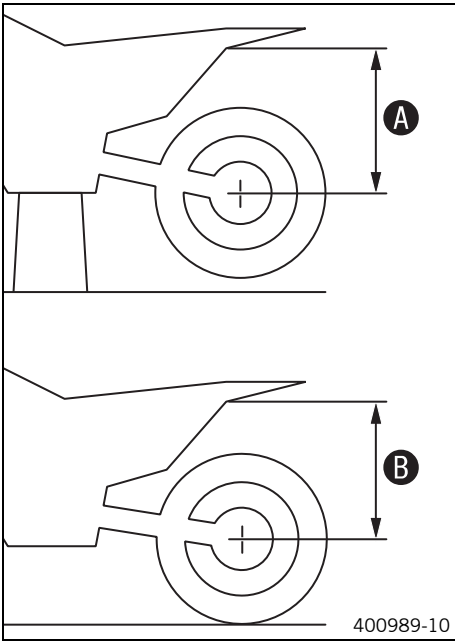

Condition

The fuel tanks are half full.

- Measure distance **A** of rear wheel unloaded. (🔧 p. 33)
- Hold the motorcycle upright with the aid of an assistant.
- Measure the distance between the rear axle and the fixed point again.
- Note down the value as dimension **B**.

Info

The static sag is the difference between measurements **A** and **B**.

- Check the static sag.

Static sag	36 mm (1.42 in)
------------	-----------------

- » If the static sag is less or more than the specified value:
 - Adjust the spring preload of the shock absorber. 🛠️ (🔧 p. 34)

10.8 Checking the riding sag of the shock absorber

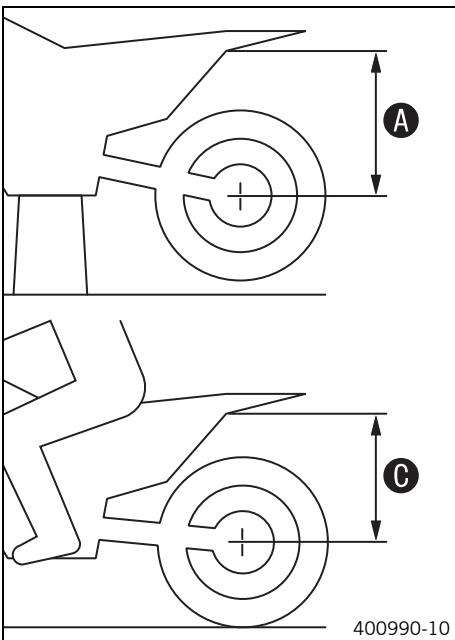

Condition

The fuel tanks are half full.

- Measure distance **A** of rear wheel unloaded. (🔧 p. 33)
- With another person holding the motorcycle, the rider, wearing full protective clothing, sits on the seat in a normal sitting position (feet on footrests) and bounces up and down a few times.
 - ✓ The rear wheel suspension levels out.
- Another person now measures the distance between the rear axle and a fixed point.
- Note down the value as dimension **C**.

Info

The riding sag is the difference between measurements **A** and **C**.

- Check the riding sag.

Riding sag	100 mm (3.94 in)
------------	------------------

- » If the riding sag differs from the specified measurement:
 - Adjust the riding sag. 🛠️ (🔧 p. 35)

10.9 Adjusting the spring preload of the shock absorber 🛠️

Caution

Danger of accidents Disassembly of pressurized parts can lead to injury.

- The shock absorber is filled with high density nitrogen. Adhere to the description provided. (Your authorized KTM workshop will be glad to help.)

Info

Before changing the spring preload, make a note of the present setting, e.g., by measuring the length of the spring.

Preparatory work

- Remove the shock absorber. 🛠️

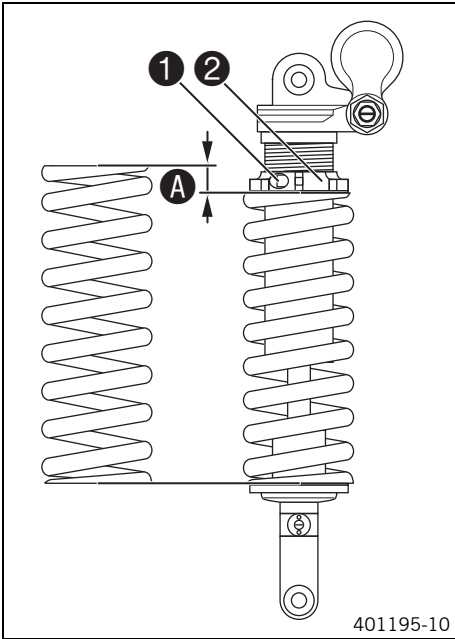

- After removing the shock absorber, clean it thoroughly.

Main work

- Loosen screw ❶.
- Turn adjusting ring ❷ until the spring is no longer under tension.

Combination wrench (50329080000)
Hook wrench (T106S)

- Measure the overall spring length when not under tension.
- Tighten the spring by turning adjusting ring ❷ to measurement A.

Guideline

Spring preload	
Standard	17 mm

i Info

Depending on the static sag and/or the riding sag, it may be necessary to increase or decrease the spring preload.

- Tighten screw ❶.

Guideline

Screw, shock absorber adjusting ring	M5	5 Nm (3.7 lbf ft)
--------------------------------------	----	-------------------

Finishing work

- Install the shock absorber. 🛠️

10.10 Adjusting the riding sag 🛠️

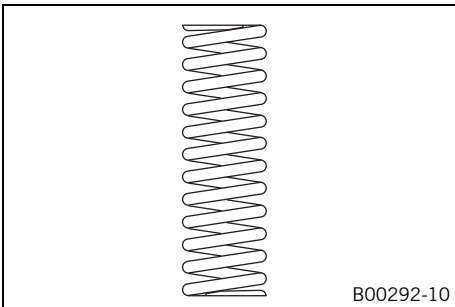

Preparatory work

- Remove the shock absorber. 🛠️
- After removing the shock absorber, clean it thoroughly.

Main work

- Choose and mount a suitable spring.

Guideline

Spring rate	
Weight of rider.: 75... 85 kg (165... 187 lb.)	80 N/mm (457 lb/in)

i Info

The spring rate is shown on the outside of the spring.

Finishing work

- Install the shock absorber. 🛠️
- Check the static sag of the shock absorber. (👉 p. 34)
- Check the riding sag of the shock absorber. (👉 p. 34)
- Adjust the rebound damping of the shock absorber. (👉 p. 33)

10.11 Checking the basic setting of the fork

i Info

For various reasons, no exact riding sag can be determined for the forks.

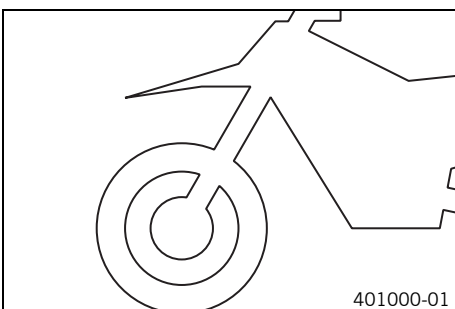

- As with the shock absorber, small differences in the rider's weight can be compensated by the spring preload.
- However, if the fork is often overloaded (hard end stop on compression), harder springs must be fit to avoid damage to the fork and frame.

10.12 Adjusting the compression damping of the fork

i Info
The hydraulic compression damping determines the fork suspension behavior.

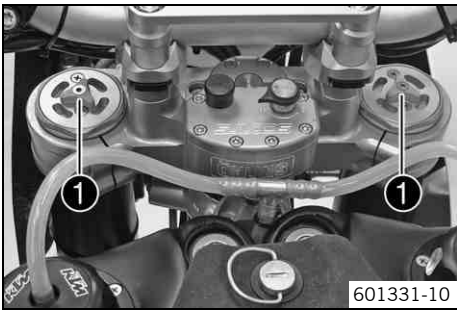

- Turn adjusting screws ❶ clockwise all the way.

i Info
Adjusting screws ❶ are located at the top end of the fork legs. Make the same adjustment on both fork legs.

- Turn back counterclockwise by the number of clicks corresponding to the fork type.

Compression damping	
Standard	10 clicks

i Info
Turn clockwise to increase damping; turn counterclockwise to reduce damping.

10.13 Adjusting the rebound damping of the fork

i Info
The hydraulic rebound damping determines the fork suspension behavior.

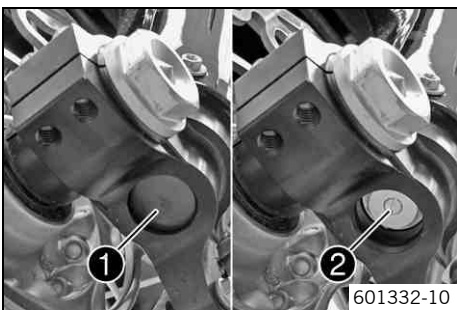

- Remove protection caps ❶.
- Turn adjusting screws ❷ clockwise all the way.

i Info
Adjusting screws ❷ are located at the bottom end of the fork legs. Make the same adjustment on both fork legs.

- Turn back counterclockwise by the number of clicks corresponding to the fork type.

Rebound damping	
Standard	20 clicks

i Info
Turn clockwise to increase damping; turn counterclockwise to reduce damping.

- Mount protection caps ❶.

10.14 Fork offset

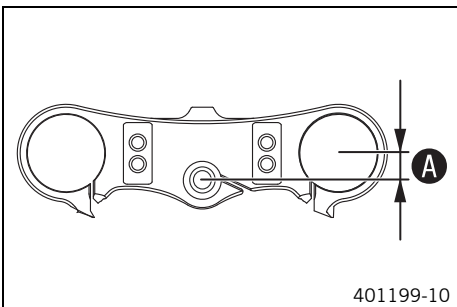

The fork offset **A** has an impact on the handling of the vehicle. It is calculated from the center of the fork leg to the center of the steering head bearing. The fork offset can optionally be adjusted.

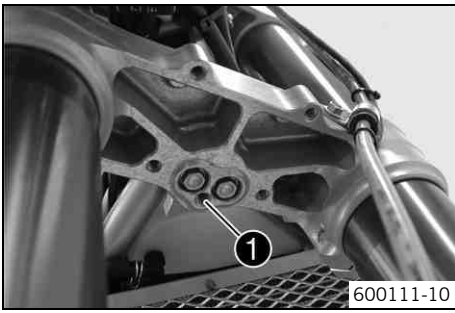

When mark 1 is visible in drill hole ❶ (as delivered), you will achieve better handling in bends.

Fork offset	
Mark 1 visible	20 mm (0.79 in)

If mark 1 is not visible in drill hole ❶, you will achieve better riding stability on fast stretches.

Fork offset	
No mark	22 mm (0.87 in)

10.15 Setting the fork offset 🛠️

Preparatory work

- Raise the motorcycle with the lift stand. (🔧 p. 40)
- Remove the front wheel. 🛠️ (🔧 p. 67)
- Dismount the front fender. (🔧 p. 41)
- Remove the fork legs. 🛠️ (🔧 p. 42)
- Remove the lower triple clamp. 🛠️ (🔧 p. 43)

Main work

- Remove screws ❶. Remove the steering stem.
- Rotate the steering stem 180° and insert into the triple clamp. Mount and tighten screws ❶.

Guideline

Screw, steering stem, bottom	M8	25 Nm (18.4 lbf ft)	Loctite® 243™
------------------------------	----	------------------------	---------------

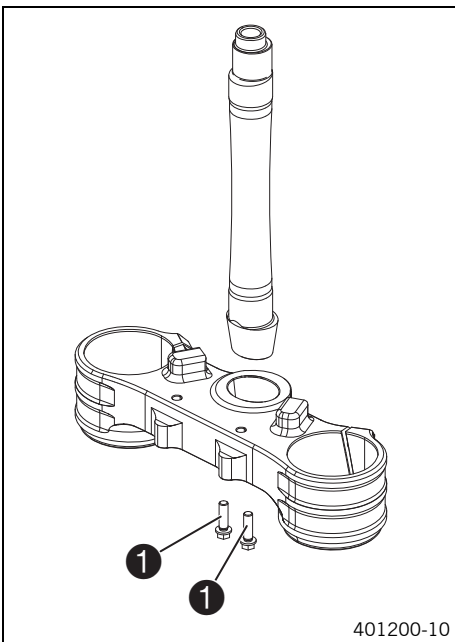

Finishing work

- Install the lower triple clamp. 🛠️ (🔧 p. 44)
- Check that the wiring harness, cables, and brake and clutch lines can move freely and are routed correctly.
- Install the front fender. (🔧 p. 41)
- Mount the front wheel. 🛠️ (🔧 p. 67)
- Check the steering head bearing play. (🔧 p. 46)
- Remove the motorcycle from the lift stand. (🔧 p. 40)

10.16 Handlebar position

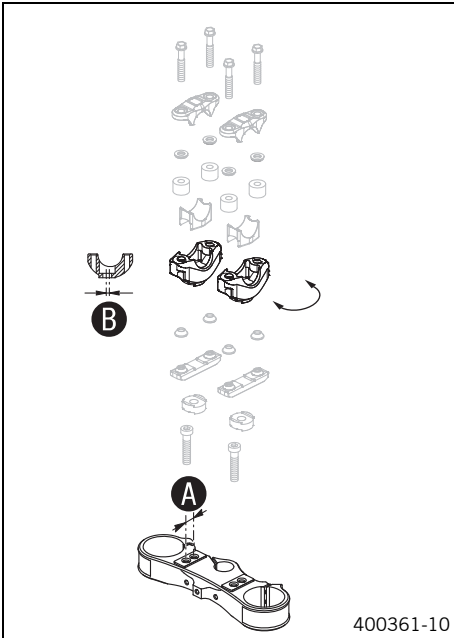

On the upper triple clamp, there are 2 holes at a distance **A** to each other.

Distance A between holes	15 mm (0.59 in)
---------------------------------	-----------------

The holes on the handlebar support are placed at a distance of **B** from the center.

Distance B between holes	3.5 mm (0.138 in)
---------------------------------	-------------------

The handlebar can be mounted in 4 different positions. In this way, the handlebar can be installed in the position most comfortable for the rider.

The handlebar supports can also be mounted at 2 different heights (with and without spacer).

Spacer height	9 mm (0.35 in)
---------------	----------------

10.17 Adjusting the handlebar position



Warning

Danger of accidents Handlebar breakage.

- If the handlebar is bent or straightened it will cause material fatigue, and the handlebar can break. Always replace handlebar.

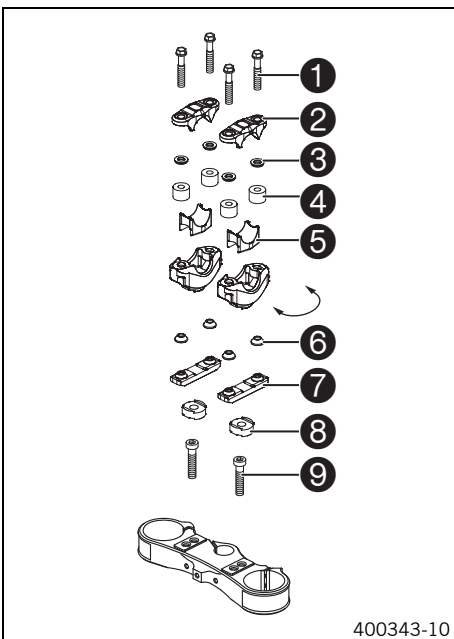

- Remove the four screws **1**. Remove handlebar clamps **2** with rubber washers **3** and elastomers **4**.
- Remove the handlebar and lay it to one side.



Info

Protect the motorcycle and its attachments against damage by covering them.
Do not bend the cables and lines.

- Remove the lower shells **5**.
- Take out clamp bar **7** with the rubber cones **6**.
- Remove the two screws **9**. Remove the handlebar supports.
- Place the handlebar supports in the required position. Mount and tighten the two screws **8**.

Guideline

Screw, handlebar support	M10	40 Nm (29.5 lbf ft)	Loctite® 243™
--------------------------	-----	------------------------	---------------

Condition

Spacer **3** mounted:

Use a M10x35 screw

Condition

Without a spacer **3**:

Use a M10x25 screw



Info

Position the left and right handlebar supports evenly.

- Insert rubber cones **6** and clamp bar **7**.

- Insert lower shells ⑤.
- Position the handlebar.



Info

Make sure cables and wiring are positioned correctly.

- Position handlebar clamps ② with rubber washers ③ and elastomers ④.

Elastomer kit green - soft quality (SXS05125203)
Elastomer kit yellow - medium quality (standard) (SXS05125204)
Elastomer kit red - hard quality (SXS05125205)



Info

The elastomers are available in different versions.

- Mount and evenly tighten the four screws ①.

Guideline

Screw, handlebar clamp	M8	16 Nm (11.8 lbf ft)
------------------------	----	------------------------



Info

Make sure the gap width is even.

11.1 Raising the motorcycle with the lift stand

Note

Danger of damage The parked vehicle may roll away or fall over.

- Always place the vehicle on a firm and even surface.



- Raise the motorcycle at the frame underneath the engine.

Lift stand (54829055000)

- ✓ The wheels must no longer touch the ground.
- Secure the motorcycle against falling over.

11.2 Removing the motorcycle from the lift stand

Note

Danger of damage The parked vehicle may roll away or fall over.

- Always place the vehicle on a firm and even surface.

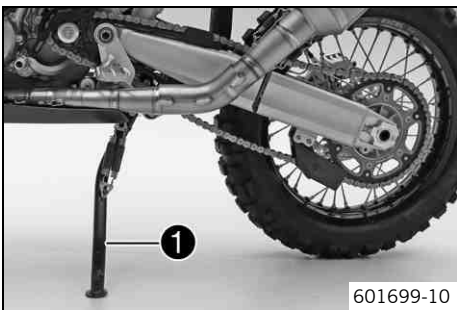

- Remove the motorcycle from the lift stand.
- Remove the lift stand.
- To park the motorcycle, press the side stand ❶ with your foot to the ground and lean the motorcycle on it.



Info

When you are riding, the side stand must be folded up and secured with the rubber band.

11.3 Bleeding the fork legs

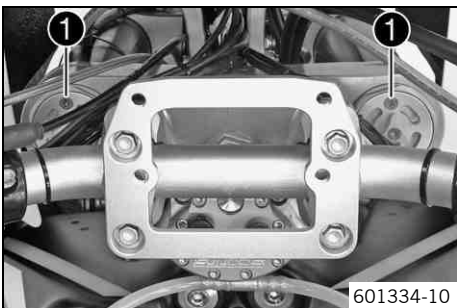

Preparatory work

- Raise the motorcycle with the lift stand. (☛ p. 40)

Main work

- Remove bleeder screws ❶ briefly.
 - ✓ Any excess pressure escapes from the interior of the fork.
- Mount and tighten the bleeder screws.

Finishing work

- Remove the motorcycle from the lift stand. (☛ p. 40)

11.4 Cleaning the dust boots of the fork legs



Preparatory work

- Raise the motorcycle with the lift stand. (☞ p. 40)
- Dismount the front fender. (☞ p. 41)

Main work

- Push dust boots ❶ of both fork legs downward.

Info

The dust boots should remove dust and coarse dirt particles from the fork tubes. Over time, dirt can penetrate behind the dust boots. If this dirt is not removed, the oil seals behind can start to leak.

Warning

Danger of accidents Reduced braking efficiency due to oil or grease on the brake discs.

- Always keep the brake discs free of oil and grease, and clean them with brake cleaner when necessary.

- Clean and oil the dust boots and inner fork tube of both fork legs.

Universal oil spray (☞ p. 119)

- Press the dust boots back into their normal position.
- Remove excess oil.

Finishing work

- Install the front fender. (☞ p. 41)
- Remove the motorcycle from the lift stand. (☞ p. 40)

11.5 Dismounting the front fender

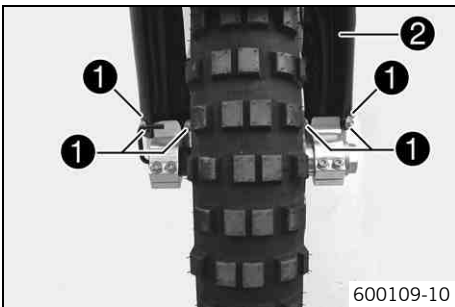

- Remove screws ❶. Remove front fender ❷.

11.6 Installing the front fender

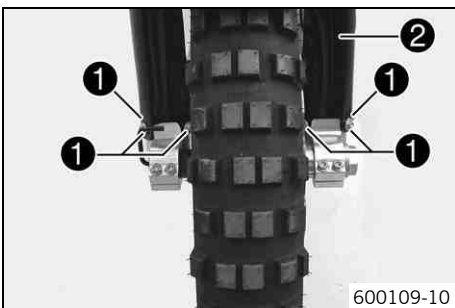

- Position front fender ❷. Mount and tighten screws ❶.

Guideline

Remaining screws, chassis	M6	10 Nm (7.4 lbf ft)
---------------------------	----	--------------------

11.7 Removing the fork legs

Preparatory work

- Raise the motorcycle with the lift stand. (☞ p. 40)
- Remove the front wheel. (☞ p. 67)
- Dismount the front fender. (☞ p. 41)

Main work

- Remove screws ❶.
- Allow the brake caliper and brake line to hang tension-free to the side.

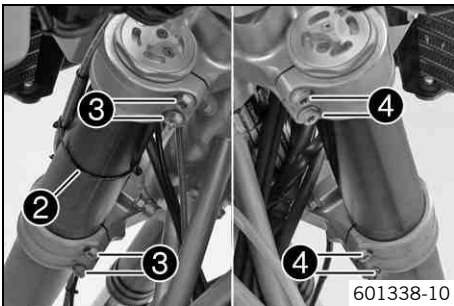
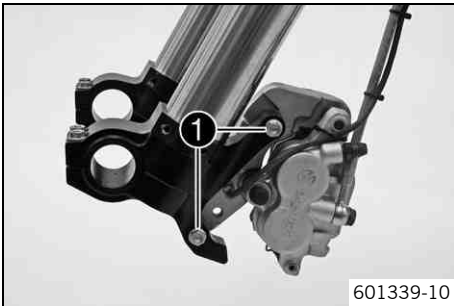

- Remove cable binder ❷.
- Loosen screws ❸. Take out the left fork leg.
- Loosen screws ❹. Take out the right fork leg.

11.8 Removing the fork legs

Preparatory work

- Raise the motorcycle with the lift stand. (☞ p. 40)
- Remove the front wheel. (☞ p. 67)
- Dismount the front fender. (☞ p. 41)

Main work

- Remove screws ❶.
- Allow the brake caliper and brake line to hang tension-free to the side.

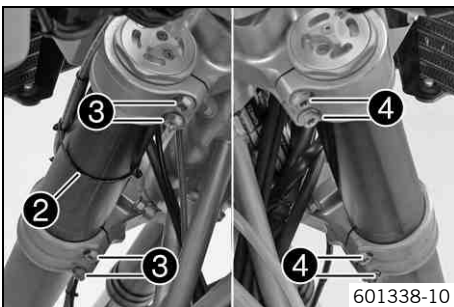
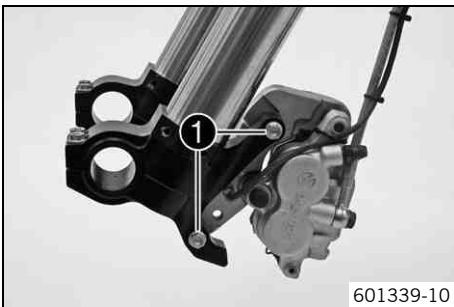

- Remove cable binder ❷.
- Loosen screws ❸. Take out the left fork leg.
- Loosen screws ❹. Take out the right fork leg.

11.9 Installing the fork legs

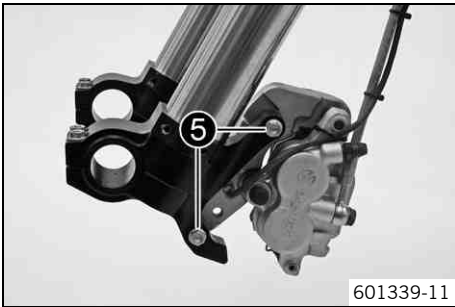
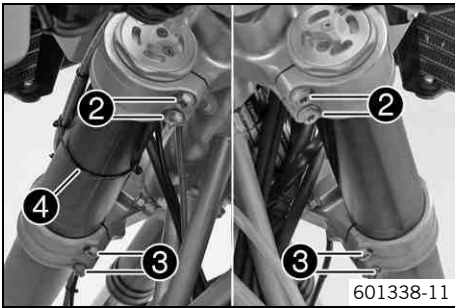
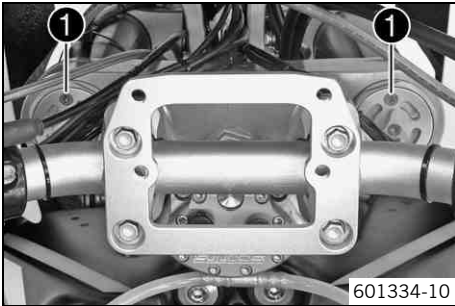

Main work

- Position the fork legs.

Info

The upper triple clamp must be flush with the upper edge of the fork legs. Position bleeder screws 1 toward the front.

- Tighten screws 2.

Guideline

Screw, top triple clamp	M8	17 Nm (12.5 lbf ft)
-------------------------	----	------------------------

- Tighten screws 3.

Guideline

Screw, bottom triple clamp	M8	12 Nm (8.9 lbf ft)
----------------------------	----	--------------------

- Secure the brake line with cable binder 4.

- Position the brake caliper. Mount and tighten screws 5.

Guideline

Screw, front brake caliper	M8	30 Nm (22.1 lbf ft)	Loctite® 243™
----------------------------	----	------------------------	---------------

Finishing work

- Install the front fender. (☞ p. 41)
- Mount the front wheel. (☞ p. 67)

11.10 Removing the lower triple clamp

Preparatory work

- Raise the motorcycle with the lift stand. (☞ p. 40)
- Remove the front wheel. (☞ p. 67)
- Dismount the front fender. (☞ p. 41)
- Remove the fork legs. (☞ p. 42)

Main work

- Remove screw 1.
- Allow the brake caliper and brake line to hang tension-free to the side.

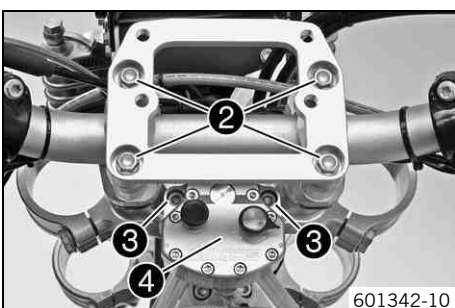
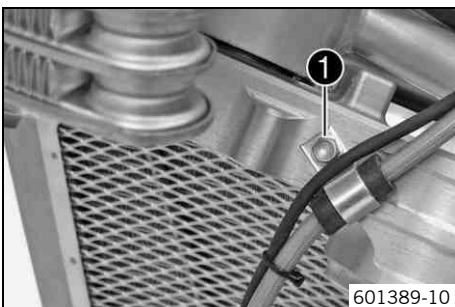

- Remove screws 2. Remove the holding plate with handlebar clamps.
- Remove screws 3. Remove steering damper 4.

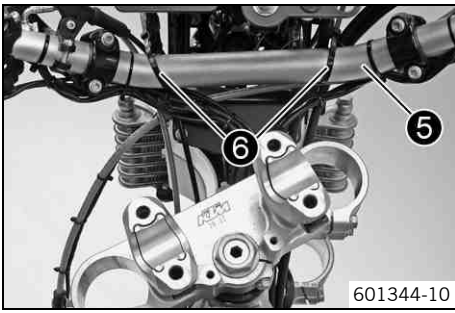

- Fix handlebar 5 onto the instrument support with cable binders 6.

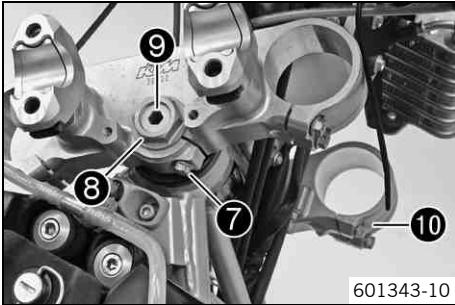

- Loosen screws 7 and 8.
- Remove screw 9 and secure against falling out under triple clamp 10.

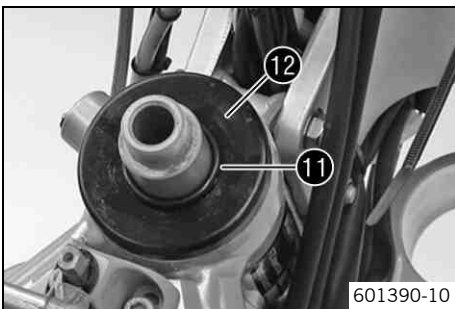

- Remove O-ring 11. Remove protective ring 12 and take off the seal ring beneath it.
- Take out the lower triple clamp with the steering stem.
- Remove the upper steering head bearing.

11.11 Installing the lower triple clamp

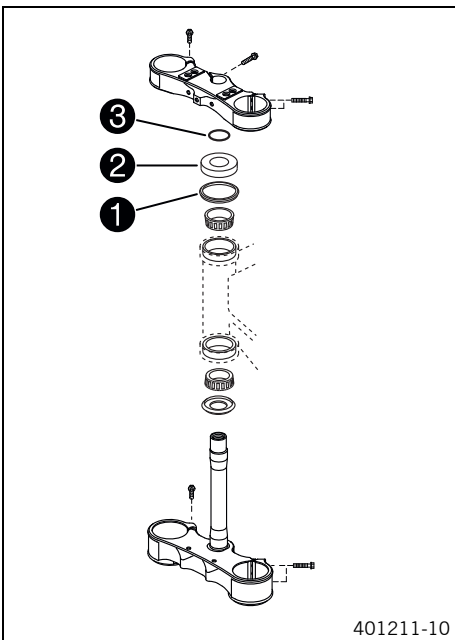

Main work

- Clean the bearing and sealing elements, check for damage, and grease.

High viscosity grease (☛ p. 118)

- Insert the lower triple clamp with the steering stem. Mount the upper steering head bearing.
- Check whether the top steering head seal 1 is correctly positioned.
- Slide on protective ring 2 and O-ring 3.

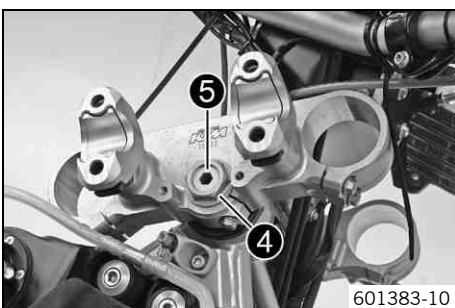

- Position the upper triple clamp.
- Mount nut 4 with screw 5 but do not tighten yet.

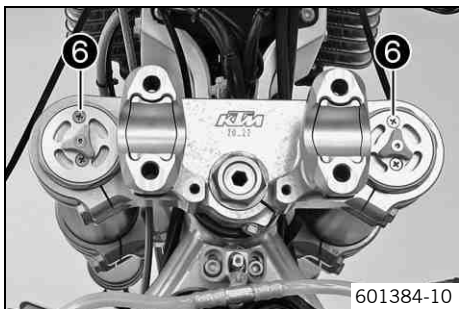

- Position the fork legs.



Info

The fork legs must be flush with the upper edge of the upper triple clamp. Position bleeder screws 6 toward the front.

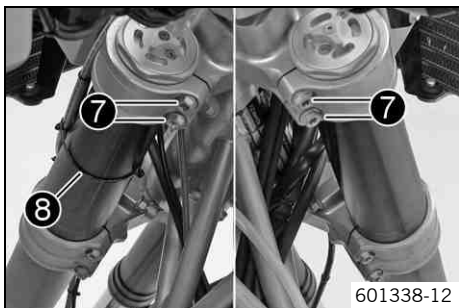

- Tighten screws 7.

Guideline

Screw, top triple clamp	M8	17 Nm (12.5 lbf ft)
-------------------------	----	---------------------

- Secure the brake line on the fork leg with cable binder 8.

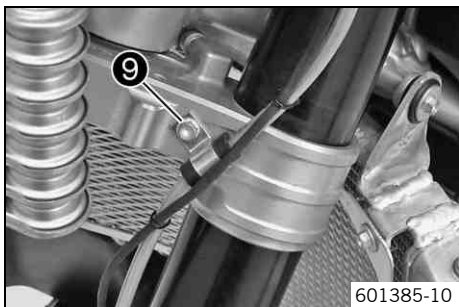

- Mount and tighten screws 9.

Guideline

Screw, brake line holder on bottom triple clamp	M5	2 Nm (1.5 lbf ft)
---	----	-------------------

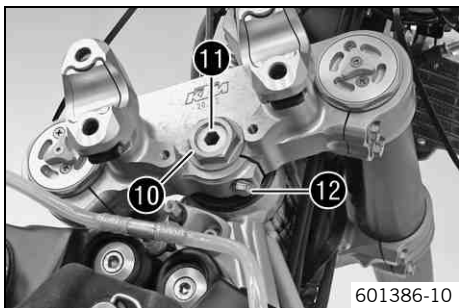

- Tighten nut 10.

Guideline

Nut, upper steering head	M20x1	12 Nm (8.9 lbf ft)
--------------------------	-------	--------------------

- Lock screw 11 with nut 10.

Guideline

Screw, top steering head	M20x1	12 Nm (8.9 lbf ft)
--------------------------	-------	--------------------

- Tighten screw 12.

Guideline

Screw, top steering stem	M8	20 Nm (14.8 lbf ft)
--------------------------	----	---------------------

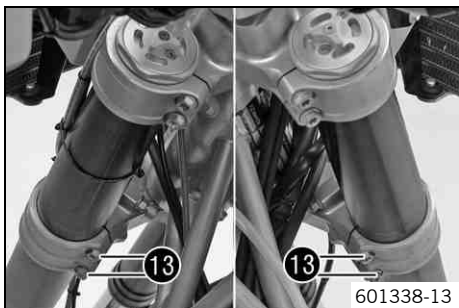

- Tighten screws 13.

Guideline

Screw, bottom triple clamp	M8	12 Nm (8.9 lbf ft)
----------------------------	----	--------------------

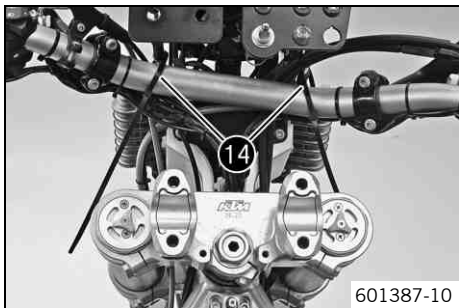

- Remove cable binders 14 and place the handlebar onto the handlebar clamp base.

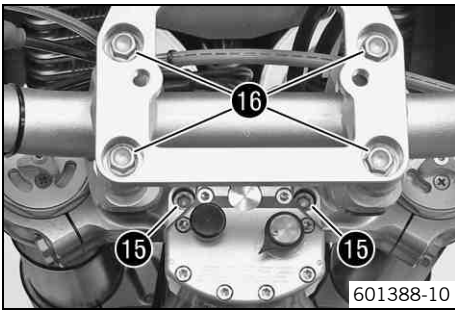

- Position the steering damper. Mount and tighten screws 15.

Guideline

Screw, steering damper	M6	15 Nm (11.1 lbf ft)
------------------------	----	------------------------

- Mount the holding plate with the handlebar clamps and position the handlebar. Mount and tighten screws 16.

Guideline

Screw, handlebar clamp	M8	16 Nm (11.8 lbf ft)
------------------------	----	------------------------

Finishing work

- Check that the wiring harness, cables, and brake and clutch lines can move freely and are routed correctly.
- Install the front fender. (☞ p. 41)
- Mount the front wheel. 🛠️ (☞ p. 67)
- Check the steering head bearing play. (☞ p. 46)
- Remove the motorcycle from the lift stand. (☞ p. 40)

11.12 Checking the steering head bearing play

Warning
Danger of accidents Unstable vehicle handling from incorrect steering head bearing play.

- Adjust the steering head bearing play without delay. (Your authorized KTM workshop will be glad to help.)

Info
 If the bike is ridden with play in the steering head bearing, the bearing and the bearing seats in the frame can become damaged over time.

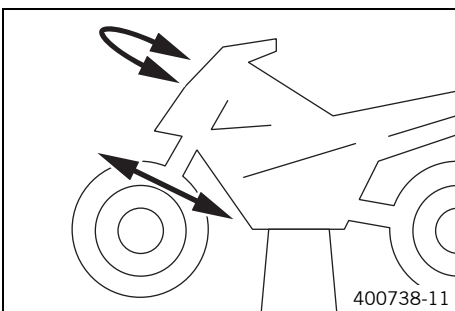

Preparatory work

- Raise the motorcycle with the lift stand. (☞ p. 40)

Main work

- Move the handlebar to the straight-ahead position. Move the fork legs to and fro in the direction of travel.

No play should be noticeable in the steering head bearing.

- » If there is noticeable play present:
 - Adjust the play of the steering head bearing. 🛠️ (☞ p. 46)
- Move the handlebar to and fro over the entire steering range.

The handlebar must be able to move easily over the entire steering range. No resting locations should be noticeable.

- » If click positions are noticeable:
 - Adjust the play of the steering head bearing. 🛠️ (☞ p. 46)
 - Check the steering head bearing and replace if required.

Finishing work

- Remove the motorcycle from the lift stand. (☞ p. 40)

11.13 Adjusting the play of the steering head bearing 🛠️

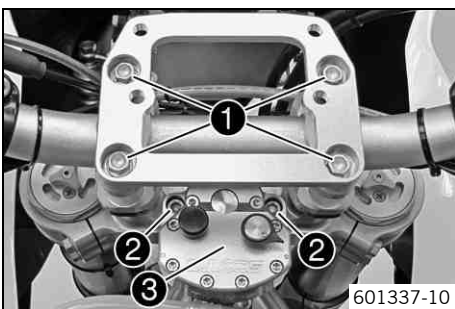

- Remove screws 1. Remove the holding plate with handlebar clamps.
- Remove screws 2. Take off steering damper 3.

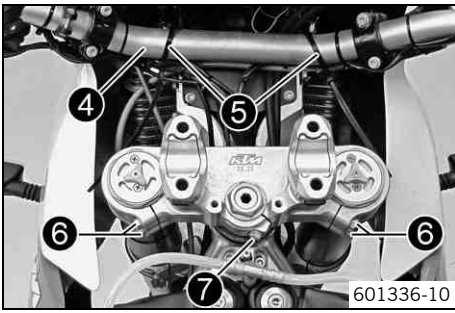

- Fix handlebar ④ onto the instrument support with cable binders ⑤.
- Loosen screws ⑥ and ⑦.

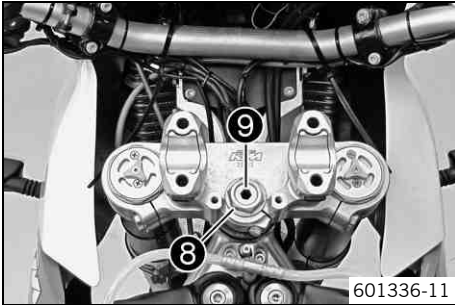

- Loosen nut ⑧ and screw ⑨.
- Retighten nut ⑧.

Guideline

Nut, upper steering head	M20x1	12 Nm (8.9 lbf ft)
--------------------------	-------	--------------------

- Lock screw ⑨ and nut ⑧.

Guideline

Screw, top steering head	M20x1	12 Nm (8.9 lbf ft)
--------------------------	-------	--------------------

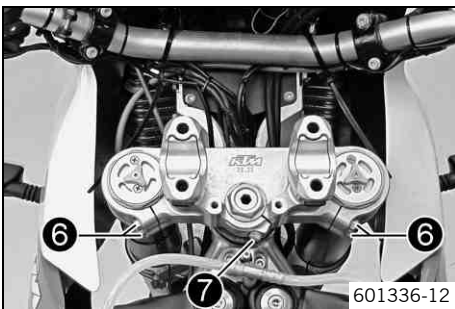

- Tighten screw ⑦.

Guideline

Screw, top steering stem	M8	20 Nm (14.8 lbf ft)
--------------------------	----	------------------------

- Tighten screws ⑥.

Guideline

Screw, top triple clamp	M8	17 Nm (12.5 lbf ft)
-------------------------	----	------------------------

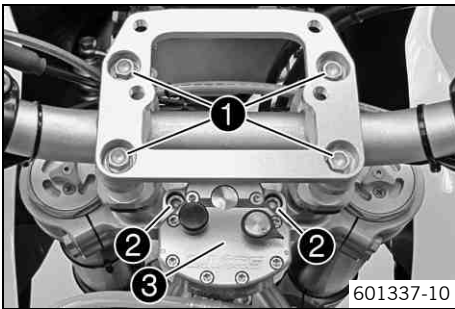

- Position steering damper ③. Mount and tighten screws ②.

Guideline

Screw, steering damper	M6	15 Nm (11.1 lbf ft)
------------------------	----	------------------------

- Remove the cable binders and place the handlebar onto the handlebar clamp base.
- Mount the holding plate with the handlebar clamps and position the handlebar. Mount and tighten screws ①.

Guideline

Screw, handlebar clamp	M8	16 Nm (11.8 lbf ft)
------------------------	----	------------------------

11.14 Greasing the steering head bearing 🛠️

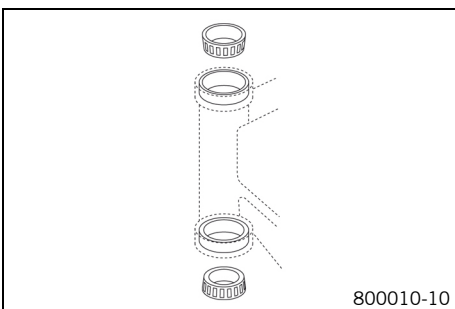

- Remove the lower triple clamp. 🛠️ (📄 p. 43)
- Install the lower triple clamp. 🛠️ (📄 p. 44)

11.15 Removing the seat



- Lift and turn quick release bracket ❶.
- Pull on loop ❷. At the same time, lift the seat at the rear and take it off.

11.16 Mounting the seat

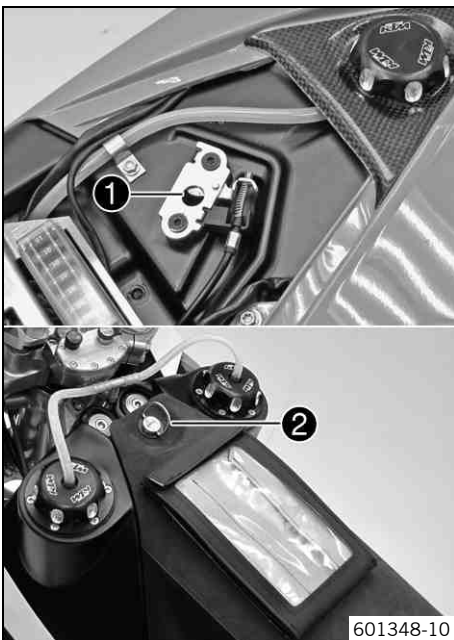

- Let the locking pin of the seat engage in lock housing ❶.
- Lock the seat at the front with quick release ❷.
- Make sure that the seat is correctly locked in.

11.17 Removing the air filter

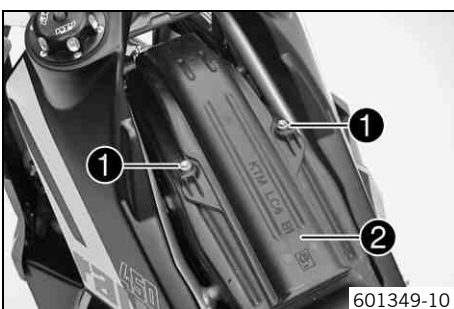

Preparatory work

- Remove the seat. (☛ p. 48)

Main work

- Remove screws ❶. Take off air filter box lid ❷.

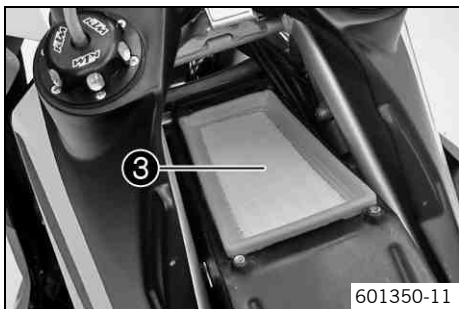

Note

Engine failure Unfiltered intake air has a negative effect on the service life of the engine.

- Never ride the vehicle without an air filter since dust and dirt can get into the engine and result in increased wear.

- Remove air filter ③.

11.18 Installing the air filter



Main work

- Clean the air filter box.
- Mount air filter ①.



Info

The air filter must lie flush against the air filter box along the entire sealing surface.

- Hook air filter box lid ② into the front of the air filter box and swing down.

- Mount and tighten screws ③.

Guideline

Screw, air filter box top	M6	2 Nm (1.5 lbf ft)
---------------------------	----	-------------------

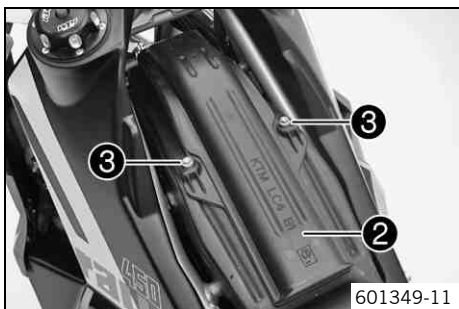

Finishing work

- Mount the seat. (☛ p. 48)

11.19 Removing the main silencer



Warning

Danger of burns The exhaust system gets very hot when the vehicle is driven.

- Allow the exhaust system to cool down. Do not touch hot components.

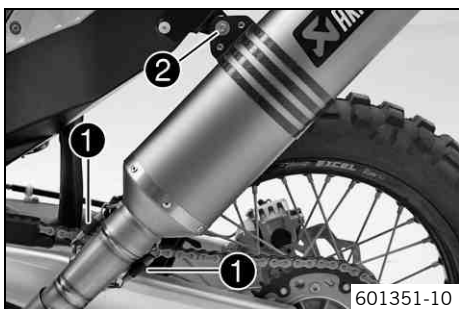

- Detach springs ①.
- Remove screw ② and take off the main silencer.

11.20 Installing the main silencer

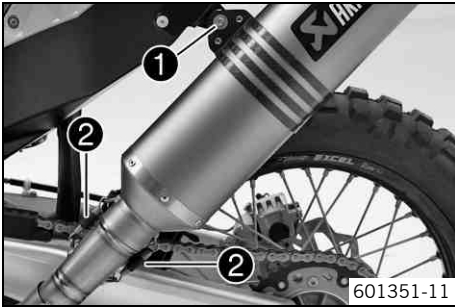

- Mount the main silencer. Mount and tighten screw ①.

Guideline

Remaining screws, chassis	M6	10 Nm (7.4 lbf ft)
---------------------------	----	--------------------

- Attach springs ②.

11.21 Changing the glass fiber yarn filling of the main silencer



Warning

Danger of burns The exhaust system gets very hot when the vehicle is driven.

- Allow the exhaust system to cool down. Do not touch hot components.



Info

Over a period, the fibers of the insulating material vanish into the air, and the silencer "burns out". Not only is the noise level higher, the performance characteristic changes.

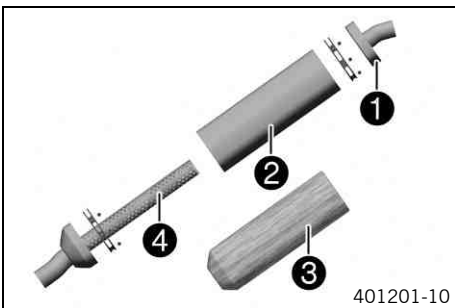

Preparatory work

- Remove the main silencer. (☛ p. 49)

Main work

- Drill out all rivets on the main silencer and remove the steel bands. Carefully hammer the rivets inward.
- Remove locking cap ① and outer tube ②.
- Pull the glass fiber yarn filling ③ from inner tube ④.
- Clean the parts that are to be reinstalled.
- Wind adhesive tape around the end of the inner tube.
- Mount the new glass fiber yarn filling on the inner tube.
- Remove the adhesive tape from the inner tube.
- Slide the outer tube over the glass fiber yarn filling.
- Insert the locking cap into the outer tube.
- Position the steel bands and mount the rivets.

Finishing work

- Install the main silencer. (☛ p. 50)

11.22 Removing the fuel tank toward the front



Danger

Fire hazard Fuel is highly flammable.

- Never refuel the vehicle near open flames or burning cigarettes, and always switch off the engine first. Be careful that no fuel is spilt, especially on hot vehicle components. Clean up spilt fuel immediately.
- Fuel in the fuel tank expands when warm and can escape if the tank is overfilled. See the notes on refueling.



Warning

Danger of poisoning Fuel is poisonous and a health hazard.

- Avoid contact between fuel and skin, eyes and clothing. Do not inhale fuel vapors. If fuel gets into your eyes, rinse immediately with water and contact a doctor. Wash affected skin areas immediately with soap and water. If fuel is swallowed, contact a doctor immediately. Change clothing that has come into contact with fuel. Store fuel in a suitable canister according to regulations and keep it out of the reach of children.

Preparatory work

- Remove the trim. (☛ p. 57)
- Remove the seat. (☛ p. 48)

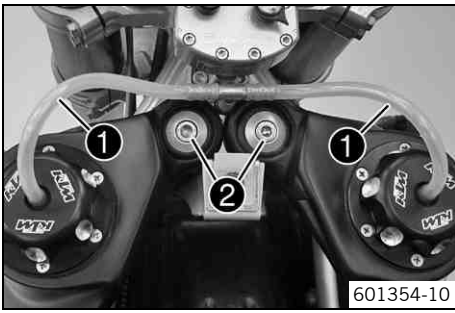

Main work

- Pull off the fuel tank breathers ❶.
- Remove screws ❷.

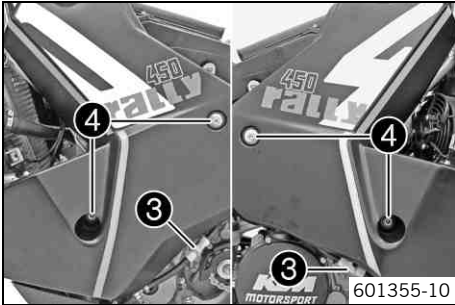

- Open the quick release of the fuel line ❸ on the left and right.
- Remove screws ❹ of the left and right halves of the fuel tank.
- Remove the fuel tank on the left and right.



Info

Set the fuel tank halves down in an upright position as otherwise fuel can escape from the fuel tank breathers at the filler cap.

11.23 Installing the fuel tank at the front

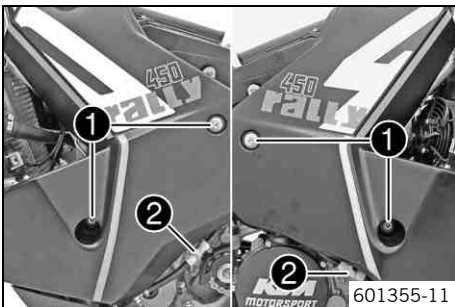

Main work

- Position the fuel tank. Mount and tighten screws ❶.

Guideline

Screw, front fuel tank	M8	8 Nm (5.9 lbf ft)
------------------------	----	-------------------

- Clean quick release of fuel line ❷ and connect it.
- Repeat the operation on the opposite side.

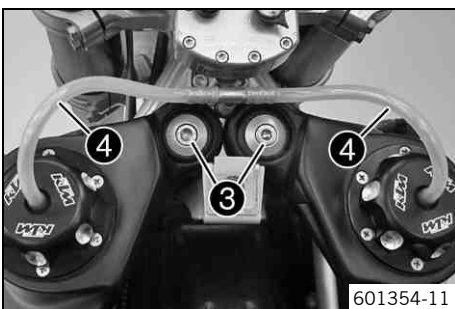

- Mount and tighten screws ❸.

Guideline

Screw, front fuel tank	M8	8 Nm (5.9 lbf ft)
------------------------	----	-------------------

- Connect the hoses ❹ of the fuel tank breather without kinking.

Finishing work

- Mount the seat. (☛ p. 48)
- Mount the trim. (☛ p. 57)

11.24 Checking the chain for dirt accumulation

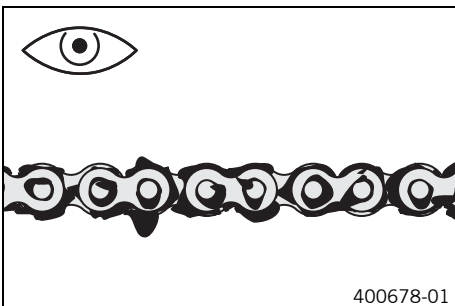

- Check the chain for coarse dirt accumulation.
 - » If the chain is very dirty:
 - Clean the chain. (☛ p. 52)

11.25 Cleaning the chain

Warning
Danger of accidents Oil or grease on the tires reduces their grip.
 – Remove oil and grease with a suitable cleaning material.

Warning
Danger of accidents Reduced braking efficiency due to oil or grease on the brake discs.
 – Always keep the brake discs free of oil and grease, and clean them with brake cleaner when necessary.

Warning
Environmental hazard Hazardous substances cause environmental damage.
 – Oil, grease, filters, fuel, cleaners, brake fluid, etc., should be disposed of as stipulated in applicable regulations.

Info
 The service life of the chain depends largely on its maintenance.

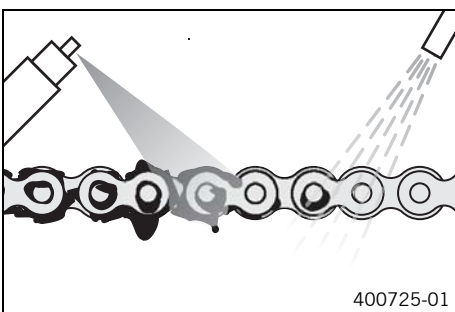

– Clean the chain regularly and then treat with chain spray.

Chain cleaner (☛ p. 118)
Off-road chain spray (☛ p. 118)

11.26 Checking the chain tension

Warning
Danger of accidents Danger caused by incorrect chain tension.
 – If the chain tension is too high, the components of the secondary power train (chain, engine sprocket, rear sprocket, bearings in transmission and rear wheel) are under additional load. Apart from premature wear, in extreme cases the chain can rupture or the countershaft of the transmission can break. On the other hand, if the chain is loose, it can fall off the engine sprocket or the rear sprocket and block the rear wheel or damage the engine. Check the chain tension and correct if necessary.

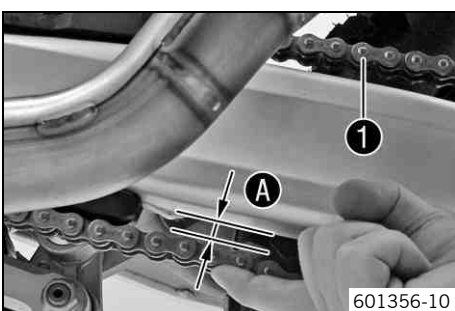

Preparatory work

– Raise the motorcycle with the lift stand. (☛ p. 40)

Main work

– Push the chain upward at the end of the chain sliding guard to measure chain tension **A**.

Info
 The upper chain section **1** must be taut.
 Chain wear is not always even, so you should repeat this measurement at different chain positions.

Chain tension	5 mm
---------------	------

» If the chain tension does not meet specifications:
 – Adjust the chain tension. (☛ p. 53)

Finishing work

– Remove the motorcycle from the lift stand. (☛ p. 40)

11.27 Adjusting the chain tension

Warning
Danger of accidents Danger caused by incorrect chain tension.

- If the chain tension is too high, the components of the secondary power train (chain, engine sprocket, rear sprocket, bearings in transmission and rear wheel) are under additional load. Apart from premature wear, in extreme cases the chain can rupture or the countershaft of the transmission can break. On the other hand, if the chain is loose, it can fall off the engine sprocket or the rear sprocket and block the rear wheel or damage the engine. Check the chain tension and correct if necessary.

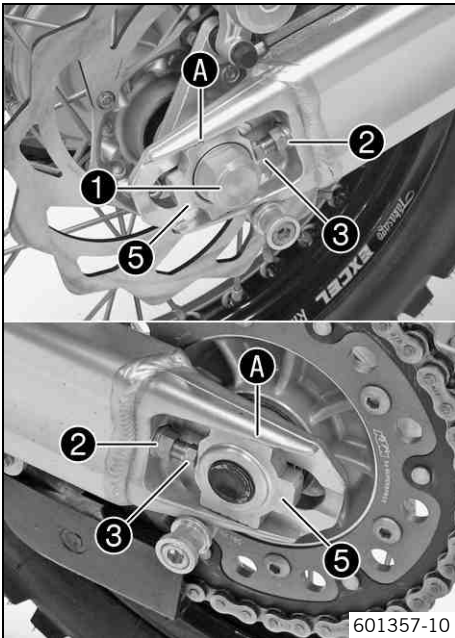

Preparatory work

- Raise the motorcycle with the lift stand. (☛ p. 40)

Main work

- Loosen nut ①.
- Loosen nuts ②.
- Adjust the chain tension by turning adjusting screws ③ left and right.

Guideline

Chain tension	5 mm
Turn adjusting screws ③ on the left and right so that the markings on the left and right chain adjusters are in the same position relative to the reference marks ④. The rear wheel is then correctly aligned.	

- Tighten nuts ②.
- Make sure that chain adjusters ④ are fitted correctly on adjusting screws ③.
- Tighten nut ①.

Guideline

Nut, rear wheel spindle	M25x1.5	90 Nm (66.4 lbf ft)
-------------------------	---------	------------------------

i Info
 The wide adjustment range of the chain adjusters enables different secondary ratios with the same chain length.
 Chain adjusters ④ can be turned by 180°.

Finishing work

- Remove the motorcycle from the lift stand. (☛ p. 40)

11.28 Checking the chain, rear sprocket, and chain guide

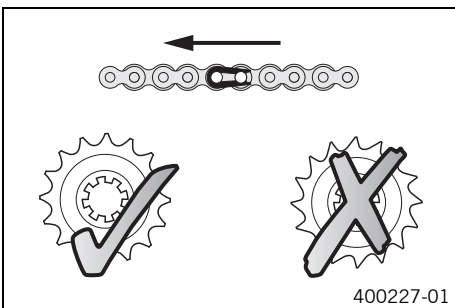

Preparatory work

- Raise the motorcycle with the lift stand. (☛ p. 40)

Main work

- Shift gear to neutral.
- Check the rear sprocket and engine sprocket for wear.
 - » If the rear sprocket and engine sprocket are worn:
 - Replace the rear sprocket or engine sprocket. ☛

i Info
 The engine sprocket, rear sprocket, and chain should always be replaced together.

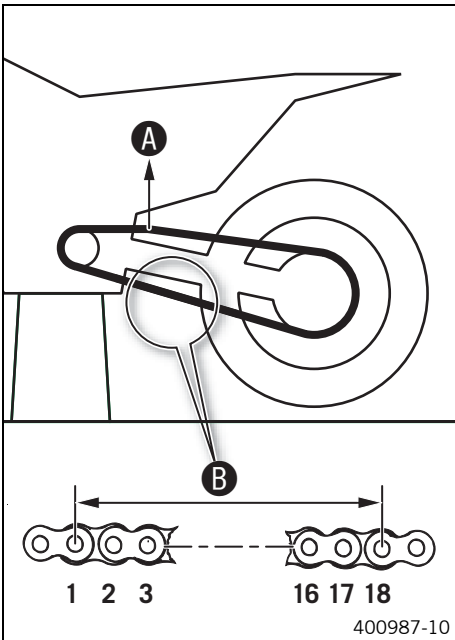

- Pull on the upper part of the chain with the specified weight **A**.

Guideline

Weight, chain wear measurement	10... 15 kg (22... 33 lb.)
--------------------------------	----------------------------

- Measure the distance **B** of 18 chain links in the lower chain section.

i **Info**

Chain wear is not always even, so you should repeat this measurement at different chain positions.

Maximum distance B at the longest chain section	272 mm (10.71 in)
--	-------------------

- » If the distance **B** is greater than the specified measurement:
 - Replace the chain. 🛠️

i **Info**

When the chain is replaced, the rear sprocket, and engine sprocket should also be changed.
New chains wear out faster on old, worn sprockets.



- Check the chain sliding guard for wear.
 - » If the bottom edge of the chain bolt is in line with or below the chain sliding guard:
 - Change the chain sliding guard. 🛠️
- Check that the chain sliding guard is firmly seated.
 - » If the chain sliding guard is loose:
 - Tighten the chain sliding guard.

Guideline

Screw, chain sliding guard	M6	6 Nm (4.4 lbf ft)	Loctite® 243™
----------------------------	----	-------------------	----------------------

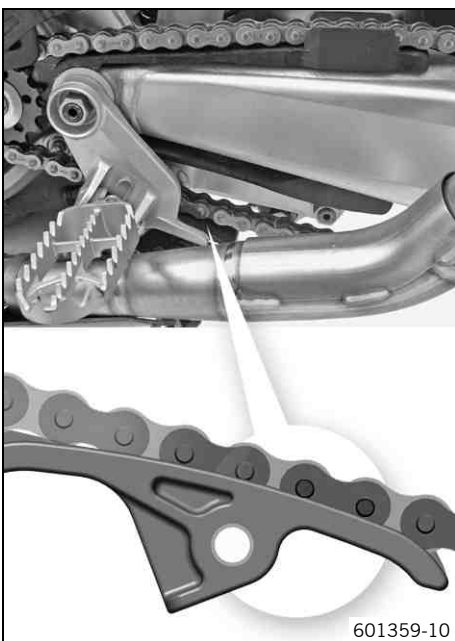

- Check the chain sliding piece for wear.
 - » If the bottom edge of the chain bolt is in line with or below the chain sliding piece:
 - Change the chain sliding piece. 🛠️
- Check that the chain sliding piece is firmly seated.
 - » If the chain sliding piece is loose:
 - Tighten the chain sliding piece.

Guideline

Screw, chain sliding piece	M8	15 Nm (11.1 lbf ft)
----------------------------	----	---------------------

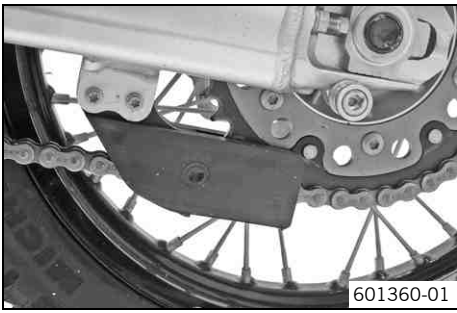

- Check the chain guide for wear.



Info

Wear is visible on the front of the chain guide.

- » If the chain guide is worn:
 - Change the chain guide. 🛠️
- Check that the chain guide is firmly seated.
 - » If the chain guide is loose:
 - Tighten the chain guide.

Guideline

Remaining screws, chassis	M6	10 Nm (7.4 lbf ft)
Remaining nuts, chassis	M6	10 Nm (7.4 lbf ft)

Finishing work

- Remove the motorcycle from the lift stand. (👉 p. 40)

11.29 Checking the frame 🛠️

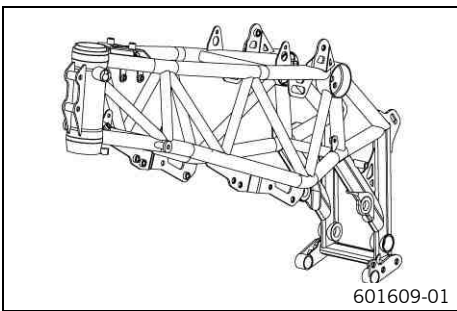

- Check the frame for cracks and deformation.
 - » If the frame exhibits cracks or deformation due to a mechanical impact:
 - Change the frame. 🛠️



Info

A frame that has been damaged due to a mechanical impact must always be changed. Repair of the frame is not authorized by KTM.

11.30 Checking the swingarm 🛠️

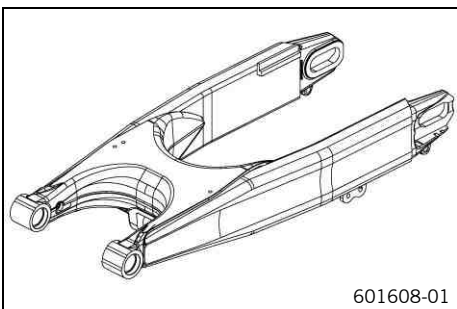

- Check the swingarm for damage, cracking, and deformation.
 - » If the swingarm shows signs of damage, cracking, or deformation:
 - Change the swingarm. 🛠️



Info

A damaged swingarm must always be changed. Repair of the swingarm is not authorized by KTM.

11.31 Checking the rubber grip

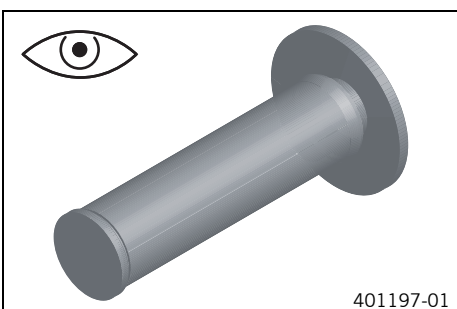

- Check the rubber grips on the handlebar for damage, wear, and looseness.
 - » If a rubber grip is damaged, worn, or loose:
 - Change and secure the rubber grip.

Rubber grip adhesive (00062030051) (👉 p. 119)

11.32 Additionally securing the rubber grip

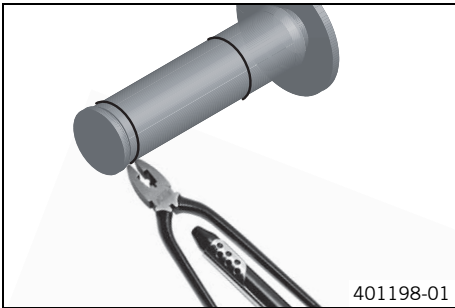

Preparatory work

- Check the rubber grip. (☞ p. 55)

Main work

- Secure the rubber grip at two points using the securing wire.

Securing wire (54812016000)

Wire twister forceps (U6907854)

- ✓ The twisted wire ends face away from the hands and are bent toward the rubber grip.

11.33 Adjusting the basic position of the clutch lever



- Adjust the basic setting of the clutch lever to your hand size by turning adjusting screw ❶.

Info

Turn the adjusting screw clockwise to increase the distance between the clutch lever and the handlebar.
Turn the adjusting screw counterclockwise to decrease the distance between the clutch lever and the handlebar.
The range of adjustment is limited.
Turn the adjusting screw by hand only, and do not apply any force.
Do not make any adjustments while riding!

11.34 Checking the fluid level of the hydraulic clutch

Info
The fluid level rises with increased wear of the clutch lining discs.
Do not use brake fluid.

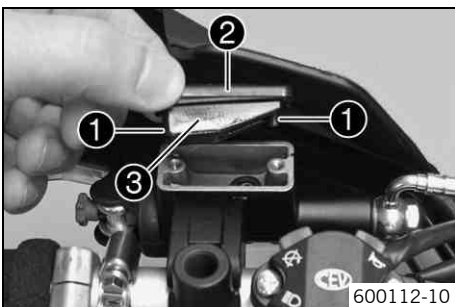

- Move the clutch fluid reservoir mounted on the handlebar to a horizontal position.
- Remove screws ❶.
- Remove cover ❷ with membrane ❸.
- Check the fluid level.

Fluid level under top level of container	4 mm (0.16 in)
--	----------------

- » If the fluid level does not meet specifications:
 - Correct the fluid level of the hydraulic clutch.

Hydraulic fluid (15) (☞ p. 117)

- Position the cover with the membrane. Mount and tighten the screws.

11.35 Changing the hydraulic clutch fluid

Warning
Environmental hazard Hazardous substances cause environmental damage.

- Oil, grease, filters, fuel, cleaners, brake fluid, etc., should be disposed of as stipulated in applicable regulations.

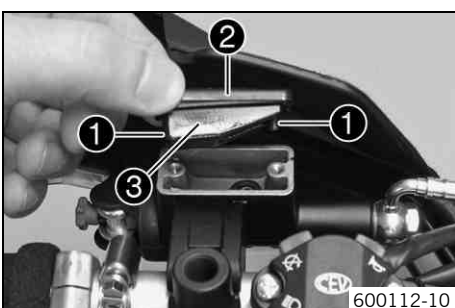

- Move the clutch fluid reservoir mounted on the handlebar to a horizontal position.
- Remove screws ❶.
- Remove cover ❷ with membrane ❸.

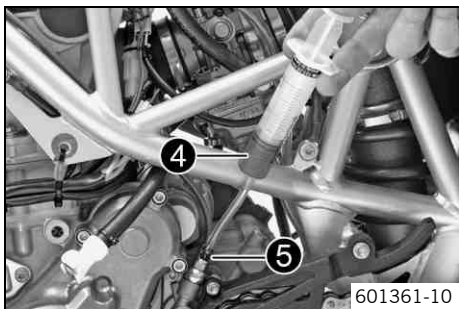

- Fill bleeding syringe 4 with the appropriate fluid.

Bleed syringe (50329050000)
Hydraulic fluid (15) (p. 117)

- On the slave cylinder, remove bleeder screw 5 and mount bleeding syringe 4.

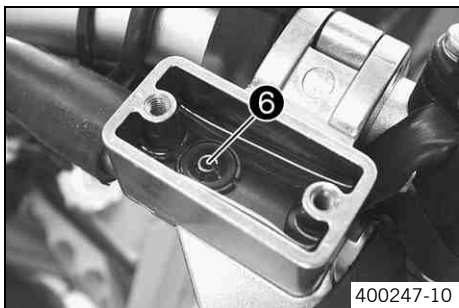

- Inject the fluid into the system until it escapes from hole 6 of the master cylinder without bubbles.
- To prevent overflow, drain the fluid occasionally from the master cylinder reservoir.
- Remove the bleeding syringe. Mount and tighten the bleeder screw.
- Correct the fluid level of the hydraulic clutch.

Guideline

Fluid level under top level of container	4 mm (0.16 in)
--	----------------

- Position the cover with the membrane. Mount and tighten the screws.

11.36 Removing the trim

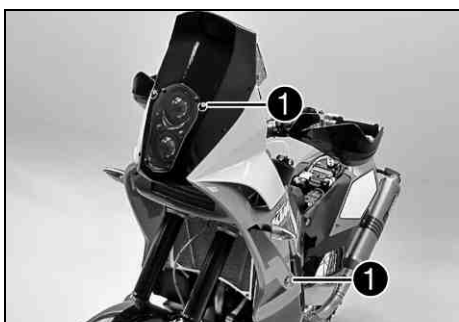

- Detach the plug-in connectors on the turn signal cables.
- Open quick releases 1.
- Remove the trim toward the front.



11.37 Mounting the trim

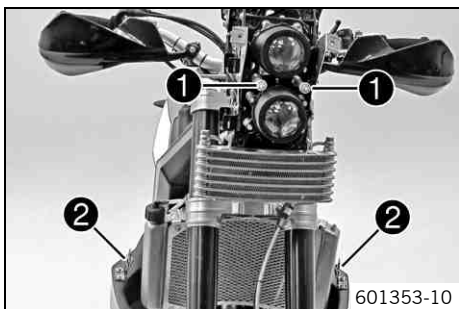

- Attach the trim to guides 1.

i Info
When positioning the trim, exercise caution with counterpieces 2 of the quick releases to ensure that you do not damage the trim.

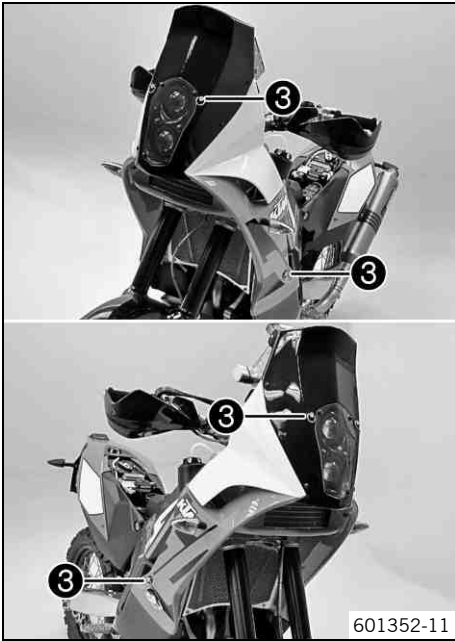

- Position the trim and attach it with quick releases ③.

12.1 Checking the free travel on the hand brake lever

Warning
Danger of accidents Brake system failure.

- If there is no free travel on the hand brake lever, pressure builds up on the front brake circuit. The front brake can fail due to overheating. Adjust the free travel on hand brake lever according to specifications.



- Push the hand brake to the handlebar and check free travel **A**.

Free travel of hand brake lever	$\geq 3 \text{ mm } (\geq 0.12 \text{ in})$
---------------------------------	---

- » If the free travel does not meet specifications:
 - Adjust the free travel of the hand brake lever. (☛ p. 59)

12.2 Adjusting the free travel of the hand brake lever

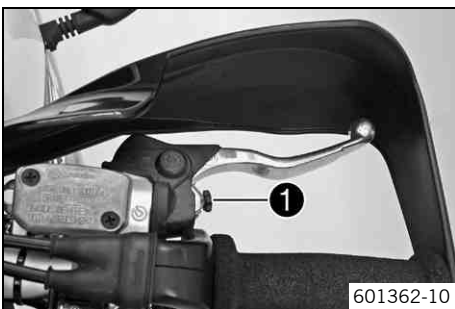

- Check the free travel on the hand brake lever. (☛ p. 59)
- Adjust the free travel of the hand brake lever with adjusting screw **1**.

i Info
 Turn the adjusting screw clockwise to reduce free travel. The pressure point moves away from the handlebar.
 Turn the adjusting screw counterclockwise to increase free travel. The pressure point moves towards the handlebar.
 The range of adjustment is limited.
 Turn the adjusting screw by hand only, and do not apply any force.
 Do not make any adjustments while riding!

12.3 Checking the brake discs

Warning
Danger of accidents Reduced braking efficiency due to worn brake disc(s).

- Change the worn brake disc(s) without delay. (Your authorized KTM workshop will be glad to help.)

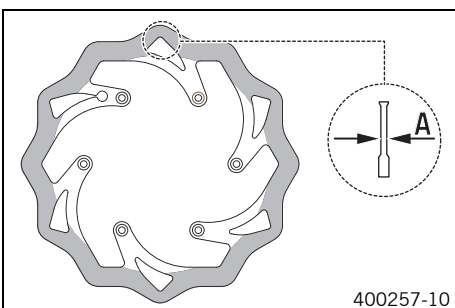

- Check the thickness of the front and rear brake discs at several places on the disc to see if it conforms to measurement **A**.

i Info
 Wear reduces the thickness of the brake disc around the area used by the brake linings.

Brake discs - wear limit	
Front	4.5 mm (0.177 in)
Rear	3.5 mm (0.138 in)

- » If the brake disc thickness is less than the specified value.
 - Change the brake disc.
- Check the front and rear brake discs for damage, cracks, and deformation.
 - » If damage, cracks, or deformation are visible on the brake disc:
 - Change brake disc.

12.4 Checking the front brake fluid level

Warning
Danger of accidents Failure of the brake system.

- If the brake fluid level falls below the **MIN** mark, this indicates a leakage in the brake system or worn-out brake linings. Check the brake system and do not continue riding. (Your authorized KTM workshop will be glad to help.)

Warning
Danger of accidents Reduced braking efficiency due to old brake fluid.

- Change the brake fluid of the front and rear brake according to the service schedule. (Your authorized KTM workshop will be glad to help.)

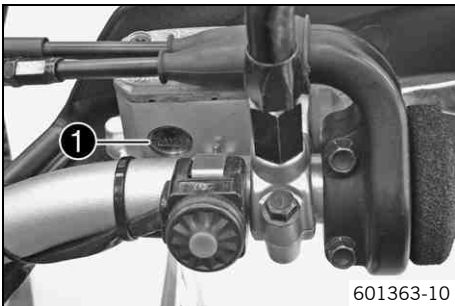

- Move the brake fluid reservoir mounted on the handlebar to a horizontal position.
- Check the brake fluid level in the viewer ①.
 - » If the brake fluid level is below the **MIN** mark:
 - Add brake fluid of the front brake. 🛠️ (📄 p. 60)

12.5 Adding front brake fluid 🛠️

Warning
Danger of accidents Failure of the brake system.

- If the brake fluid level falls below the **MIN** mark, this indicates a leakage in the brake system or worn-out brake linings. Check the brake system and do not continue riding. (Your authorized KTM workshop will be glad to help.)

Warning
Skin irritation Brake fluid can cause skin irritation on contact.

- Avoid contact with skin and eyes, and keep out of the reach of children.
- Wear suitable protective clothing and goggles.
- If brake fluid comes into contact with the eyes, flush the eyes thoroughly with water and consult a physician immediately.

Warning
Danger of accidents Reduced braking efficiency due to old brake fluid.

- Change the brake fluid of the front and rear brake according to the service schedule. (Your authorized KTM workshop will be glad to help.)

Warning
Environmental hazard Hazardous substances cause environmental damage.

- Oil, grease, filters, fuel, cleaners, brake fluid, etc., should be disposed of as stipulated in applicable regulations.

i Info
 Never use DOT 5 brake fluid! It is silicone-based and purple in color. Oil seals and brake lines are not designed for DOT 5 brake fluid.
 Avoid contact between brake fluid and painted parts. Brake fluid is corrosive!
 Use only clean brake fluid from a sealed container.

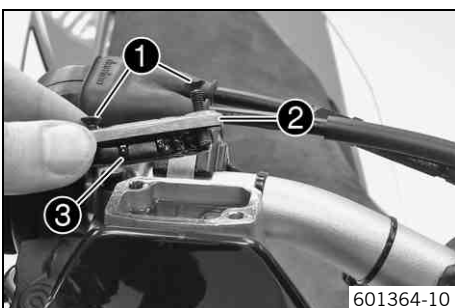

- Move the brake fluid reservoir mounted on the handlebar to a horizontal position.
- Remove screws ①.
- Remove cover ② with membrane ③.

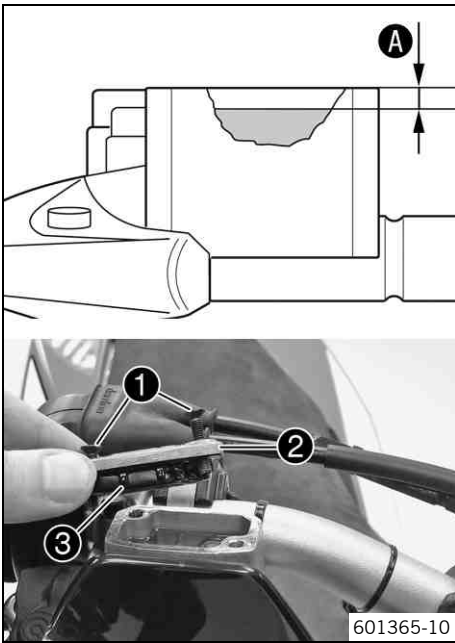

- Add brake fluid to level **A**.

Brake fluid DOT 4 / DOT 5.1 (☞ p. 116)
--

- Position cover **2** with membrane **3**.
- Mount and tighten screws **1**.

i Info

Clean up overflowed or spilt brake fluid immediately with water.

12.6 Checking the front brake linings



Warning

Danger of accidents Reduced braking efficiency caused by worn brake linings.

- Change worn brake linings immediately. (Your authorized KTM workshop will be glad to help.)

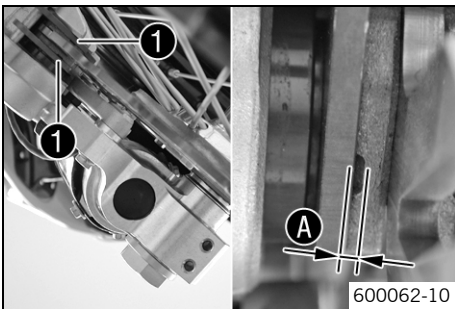

- Check brake linings **1** for minimum thickness **A**.

Minimum thickness A	≥ 1 mm (≥ 0.04 in)
----------------------------	--------------------

- » If the minimum thickness is less than specified:
 - Change the front brake linings. ☞ (☞ p. 61)
- Check the brake linings for damage and cracking.
 - » If damage or cracking is visible:
 - Change the front brake linings. ☞ (☞ p. 61)

12.7 Changing the front brake linings ☞



Warning

Danger of accident Brake system failure.

- Maintenance work and repairs must be carried out professionally. (Your authorized KTM workshop will be glad to help.)



Warning

Skin irritation Brake fluid can cause skin irritation on contact.

- Avoid contact with skin and eyes, and keep out of the reach of children.
- Wear suitable protective clothing and goggles.
- If brake fluid comes into contact with the eyes, flush the eyes thoroughly with water and consult a physician immediately.



Warning

Danger of accidents Reduced braking efficiency due to old brake fluid.

- Change the brake fluid of the front and rear brake according to the service schedule. (Your authorized KTM workshop will be glad to help.)



Warning

Danger of accidents Reduced braking efficiency due to oil or grease on the brake discs.

- Always keep the brake discs free of oil and grease, and clean them with brake cleaner when necessary.

- Warning**
Danger of accidents Reduced braking efficiency due to use of non-approved brake linings.
- Brake linings available from accessory suppliers are often not tested and approved for use on KTM vehicles. The construction and friction factor of the brake linings and therefore the brake power can differ considerably from the original KTM brake linings. If brake linings are used that differ from the originals, there is no guarantee that they comply with the original license. The vehicle no longer corresponds to the condition at delivery, and the warranty is no longer valid.

- Warning**
Environmental hazard Hazardous substances cause environmental damage.
- Oil, grease, filters, fuel, cleaners, brake fluid, etc., should be disposed of as stipulated in applicable regulations.

Info
 Never use DOT 5 brake fluid! It is silicone-based and purple in color. Oil seals and brake lines are not designed for DOT 5 brake fluid.
 Avoid contact between brake fluid and painted parts. Brake fluid is corrosive!
 Use only clean brake fluid from a sealed container.

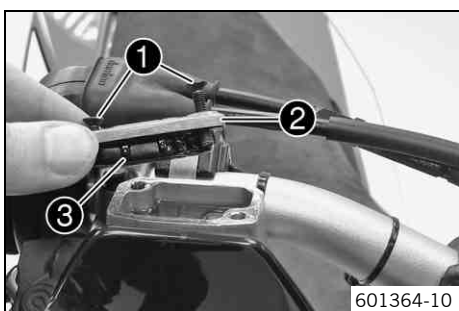

- Move the brake fluid reservoir mounted on the handlebar to a horizontal position.
- Remove screws ①.
- Remove cover ② with membrane ③.

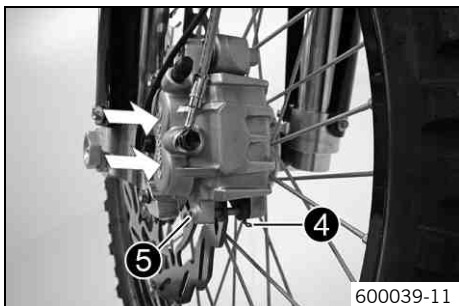

- Press the brake caliper by hand on to the brake disc in order to press back the brake pistons. Ensure that brake fluid does not overflow from the brake fluid reservoir, using suction to remove it if it does.

Info
 Make sure when pushing back the brake pistons that you do not press the brake caliper against the spokes.

- Remove cotter pin ④, withdraw pin ⑤, and take out the brake linings.

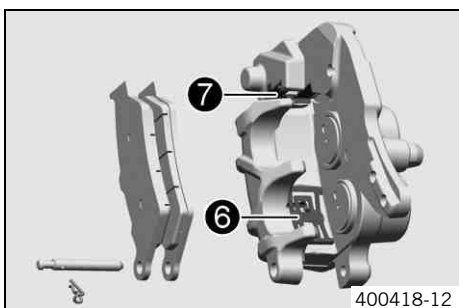

- Clean the brake caliper and brake caliper support.
- Check that leaf spring ⑥ in the brake caliper and sliding plate ⑦ in the brake caliper support are seated correctly.

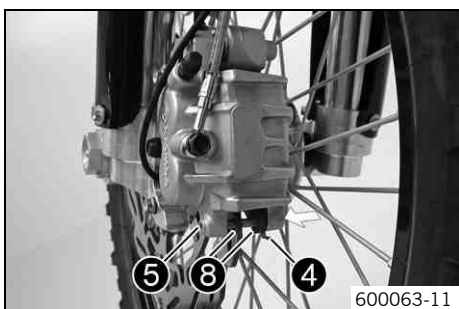

- Insert brake linings ⑧, insert pin ⑤, and mount cotter pin ④.

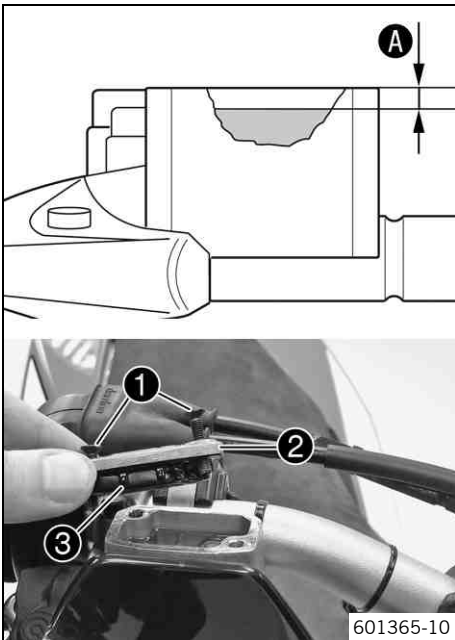

- Operate the hand brake lever repeatedly until the brake linings are in contact with the brake disc and there is a pressure point.
- Add brake fluid to level **A**.

Guideline

Measurement of A	5 mm (0.2 in)
-------------------------	---------------

Brake fluid DOT 4 / DOT 5.1 (☞ p. 116)
--

- Position cover **2** with membrane **3**.
- Mount and tighten screws **1**.

i Info
Clean up overflowed or spilt brake fluid immediately with water.

12.8 Checking the free travel of the foot brake lever

Warning
Danger of accidents Brake system failure.

- If there is no free travel on the foot brake lever, pressure builds up on the rear brake circuit. The rear brake can fail due to overheating. Adjust the free travel on foot brake lever according to specifications.

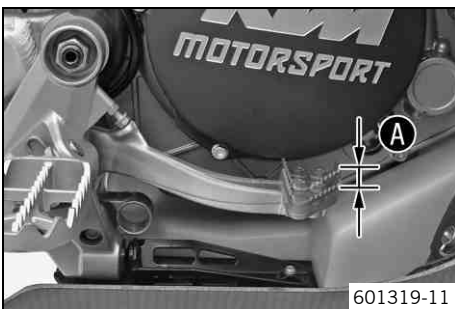

- Detach the spring from the foot brake lever.
- Move the foot brake lever back and forth between the end stop and the contact to the foot brake cylinder piston and check free travel **A**.

Guideline

Free travel at the foot brake lever	3... 5 mm (0.12... 0.2 in)
-------------------------------------	----------------------------

- » If the free travel does not meet specifications:
 - Adjust the free travel of the foot brake lever. ☞ (☞ p. 63)
- Attach the spring to the foot brake lever.

12.9 Adjusting the free travel of the foot brake lever ☞

Warning
Danger of accidents Brake system failure.

- If there is no free travel on the foot brake lever, pressure builds up on the rear brake circuit. The rear brake can fail due to overheating. Adjust the free travel on foot brake lever according to specifications.

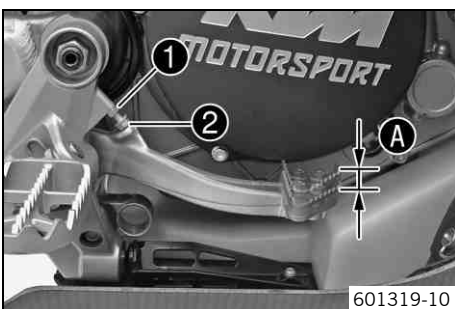

- Loosen nut **1** and use screw **2** to adjust free travel **A**.

Guideline

Free travel at the foot brake lever	3... 5 mm (0.12... 0.2 in)
-------------------------------------	----------------------------

- Hold screw **2** and tighten nut **1**.

Guideline

Remaining nuts, chassis	M6	10 Nm (7.4 lbf ft)
-------------------------	----	--------------------

12.10 Checking the rear brake fluid level

Warning
Danger of accidents Failure of the brake system.

- If the brake fluid level falls below the **MIN** mark, this indicates a leakage in the brake system or worn-out brake linings. Check the brake system and do not continue riding. (Your authorized KTM workshop will be glad to help.)

Warning
Danger of accidents Reduced braking efficiency due to old brake fluid.

- Change the brake fluid of the front and rear brake according to the service schedule. (Your authorized KTM workshop will be glad to help.)

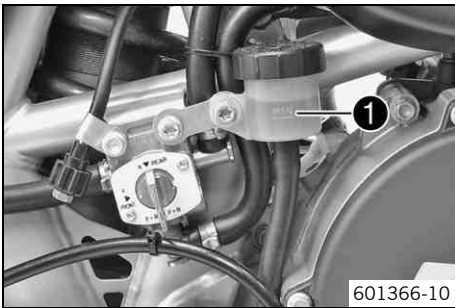

- Stand the vehicle upright.
- Check the brake fluid level in the brake fluid reservoir.
 - » If the fluid level reaches the **MIN** mark ❶:
 - Add rear brake fluid. 🛠️ (👉 p. 64)

12.11 Adding rear brake fluid 🛠️

Warning
Danger of accidents Failure of the brake system.

- If the brake fluid level falls below the **MIN** mark, this indicates a leakage in the brake system or worn-out brake linings. Check the brake system and do not continue riding. (Your authorized KTM workshop will be glad to help.)

Warning
Skin irritation Brake fluid can cause skin irritation on contact.

- Avoid contact with skin and eyes, and keep out of the reach of children.
- Wear suitable protective clothing and goggles.
- If brake fluid comes into contact with the eyes, flush the eyes thoroughly with water and consult a physician immediately.

Warning
Danger of accidents Reduced braking efficiency due to old brake fluid.

- Change the brake fluid of the front and rear brake according to the service schedule. (Your authorized KTM workshop will be glad to help.)

Warning
Environmental hazard Hazardous substances cause environmental damage.

- Oil, grease, filters, fuel, cleaners, brake fluid, etc., should be disposed of as stipulated in applicable regulations.

i Info
 Never use DOT 5 brake fluid! It is silicone-based and purple in color. Oil seals and brake lines are not designed for DOT 5 brake fluid.
 Avoid contact between brake fluid and painted parts. Brake fluid is corrosive!
 Use only clean brake fluid from a sealed container.

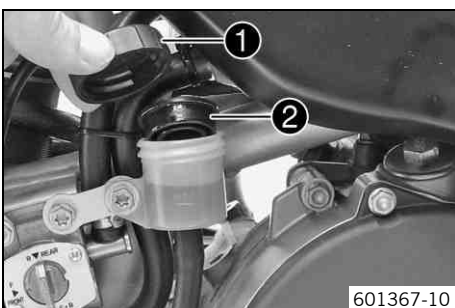

- Stand the vehicle upright.
 - Remove screw cap ❶ with the washer and membrane ❷.
 - Add brake fluid to the **MAX** level.
- Brake fluid DOT 4 / DOT 5.1 (👉 p. 116)
- Mount the screw cap with the washer and membrane.

i Info
 Clean up overflowed or spilt brake fluid immediately with water.

12.12 Checking the rear brake linings



Warning

Danger of accidents Reduced braking efficiency caused by worn brake linings.

- Change worn brake linings immediately. (Your authorized KTM workshop will be glad to help.)

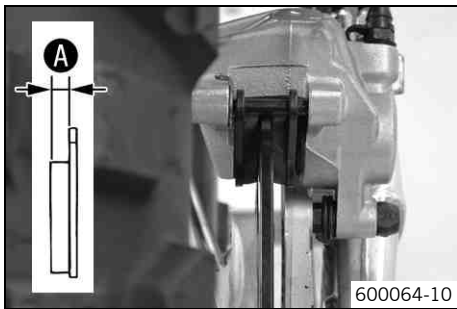

- Check the brake linings for minimum thickness **A**.

Minimum thickness A	$\geq 1 \text{ mm } (\geq 0.04 \text{ in})$
----------------------------	---

- » If the minimum thickness is less than specified:
 - Change the rear brake linings. (p. 65)
- Check the brake linings for damage and cracking.
 - » If damage or cracking is visible:
 - Change the rear brake linings. (p. 65)

12.13 Changing the rear brake linings



Warning

Danger of accident Brake system failure.

- Maintenance work and repairs must be carried out professionally. (Your authorized KTM workshop will be glad to help.)



Warning

Skin irritation Brake fluid can cause skin irritation on contact.

- Avoid contact with skin and eyes, and keep out of the reach of children.
- Wear suitable protective clothing and goggles.
- If brake fluid comes into contact with the eyes, flush the eyes thoroughly with water and consult a physician immediately.



Warning

Danger of accidents Reduced braking efficiency due to old brake fluid.

- Change the brake fluid of the front and rear brake according to the service schedule. (Your authorized KTM workshop will be glad to help.)



Warning

Danger of accidents Reduced braking efficiency due to oil or grease on the brake discs.

- Always keep the brake discs free of oil and grease, and clean them with brake cleaner when necessary.



Warning

Danger of accidents Reduced braking efficiency due to use of non-approved brake linings.

- Brake linings available from accessory suppliers are often not tested and approved for use on KTM vehicles. The construction and friction factor of the brake linings and therefore the brake power can differ considerably from the original KTM brake linings. If brake linings are used that differ from the originals, there is no guarantee that they comply with the original license. The vehicle no longer corresponds to the condition at delivery, and the warranty is no longer valid.



Warning

Environmental hazard Hazardous substances cause environmental damage.

- Oil, grease, filters, fuel, cleaners, brake fluid, etc., should be disposed of as stipulated in applicable regulations.



Info

Never use DOT 5 brake fluid! It is silicone-based and purple in color. Oil seals and brake lines are not designed for DOT 5 brake fluid.

Avoid contact between brake fluid and painted parts. Brake fluid is corrosive!

Use only clean brake fluid from a sealed container.

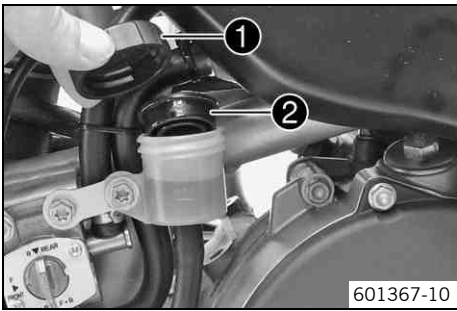

- Stand the vehicle upright.
- Remove screw cap ① with the washer and membrane ②.
- Press the brake caliper by hand on to the brake disc in order to press back the brake piston. Ensure that brake fluid does not overflow from the brake fluid reservoir, using suction to remove it if it does.



Info

Make sure when pushing back the brake piston that you do not press the brake caliper against the spokes.

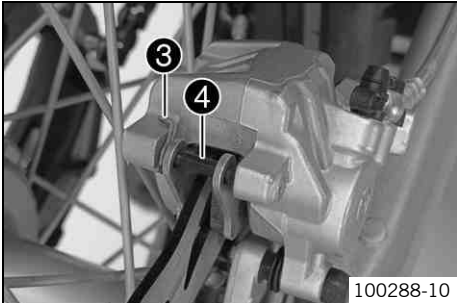

- Remove cotter pin ③, remove bolt ④ toward the left by striking it and remove the brake linings.
- Clean the brake caliper and brake caliper support.

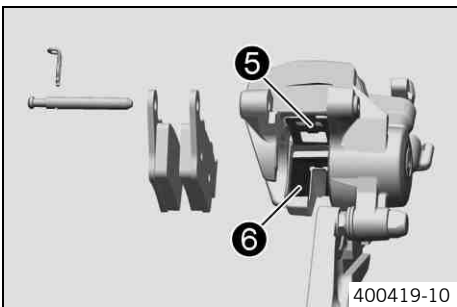

- Check that leaf spring ⑤ in the brake caliper and sliding plate ⑥ in the brake caliper support are seated correctly.

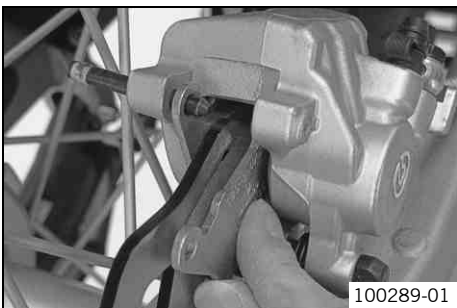

- Insert the brake linings, insert the bolt, and mount the cotter pin.
- Operate the foot brake lever repeatedly until the brake linings are in contact with the brake disc and there is a pressure point.
- Adjust the brake fluid level to the **MAX** mark.

Brake fluid DOT 4 / DOT 5.1 (☛ p. 116)

- Mount the screw cap with the washer and membrane.



Info

Clean up overflowed or spilt brake fluid immediately with water.

13.1 Removing the front wheel



Preparatory work

- Raise the motorcycle with the lift stand. (☛ p. 40)

Main work

- Press the brake caliper by hand on to the brake disc in order to press back the brake pistons.

i Info

Make sure when pushing back the brake pistons that you do not press the brake caliper against the spokes.

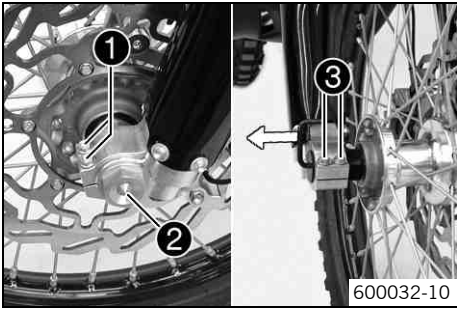

- Loosen screws ❶.
- Remove screw ❷.
- Loosen screws ❸.
- Holding the front wheel, withdraw the wheel spindle. Take the front wheel out of the fork.

i Info

Do not pull the hand brake lever when the front wheel is removed. Always lay the wheel down in such a way that the brake disc is not damaged.

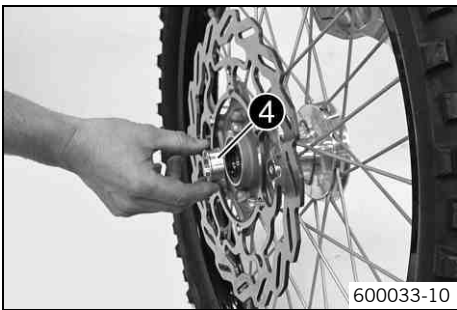

- Remove spacer ❹.

13.2 Mounting the front wheel

! Warning

Danger of accidents Reduced braking efficiency due to oil or grease on the brake discs.

- Always keep the brake discs free of oil and grease, and clean them with brake cleaner when necessary.

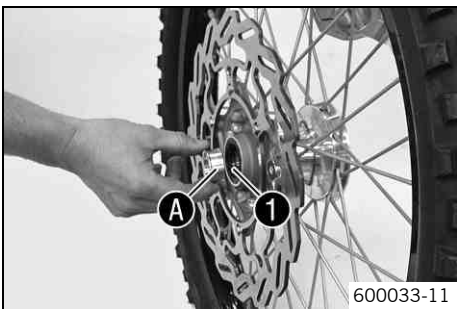

- Check the wheel bearing for damage and wear.
 - » If the wheel bearing is damaged or worn:
 - Change the wheel bearing. ☛
- Clean and grease shaft seal ring ❶ and bearing surface A of the spacer. Clean and grease the shaft seal ring on the right and the running surface of the wheel spindle.

Long-life grease (☛ p. 118)

- Insert the spacer.

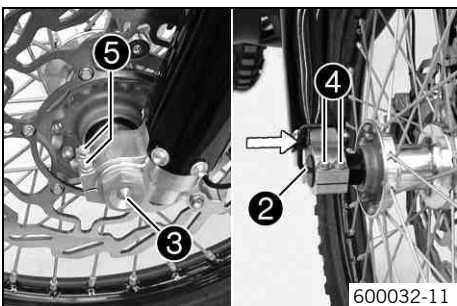

- Lift the front wheel into the fork, position it, and insert wheel spindle ❷.
- Mount and tighten screw ❸.

Guideline

Screw, front wheel spindle	M24x1.5	40 Nm (29.5 lbf ft)
----------------------------	---------	------------------------

i Info

Ensure that the grip of the wheel spindle does not contact with the right fork leg.

- Activate the hand brake lever multiple times until the brake linings are in contact with the brake disc.
- Remove the motorcycle from the lift stand. (☛ p. 40)
- Pull the front brake and compress the fork powerfully a few times.
✓ The fork legs straighten.
- Tighten screws ④ and ⑤.

Guideline

Screw, fork stub	M8	15 Nm (11.1 lbf ft)
------------------	----	------------------------

13.3 Removing the rear wheel ☛

Preparatory work

- Raise the motorcycle with the lift stand. (☛ p. 40)

Main work

- Press the brake caliper by hand on to the brake disc in order to press back the brake piston.

i Info
Make sure when pushing back the brake piston that you do not press the brake caliper against the spokes.

- Remove nut ①.
- Remove chain adjuster ②.
- Withdraw wheel spindle ③ only enough to allow the rear wheel to be pushed forward.
- Push the rear wheel forward as far as possible. Remove the chain from the rear sprocket.
- Holding the rear wheel, withdraw wheel spindle ③. Take the rear wheel out of the swingarm.

i Info
Do not operate the foot brake when the rear wheel is removed. Always lay the wheel down in such a way that the brake disc is not damaged.

- Remove spacer ④.

- Remove the rear sprocket carrier ⑤.

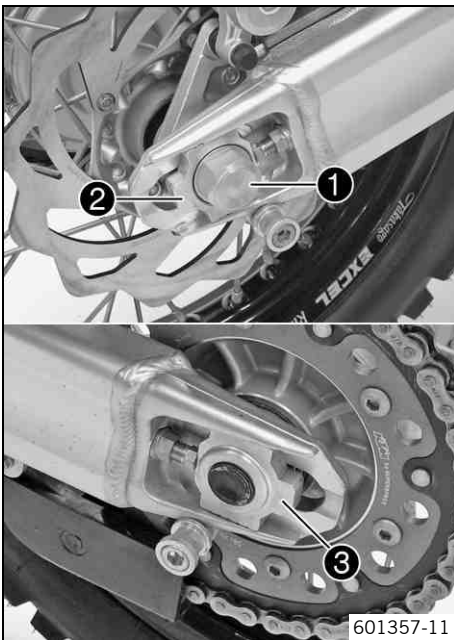

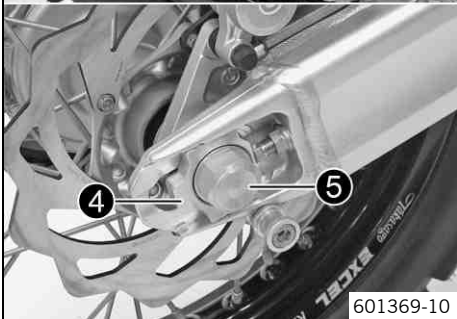
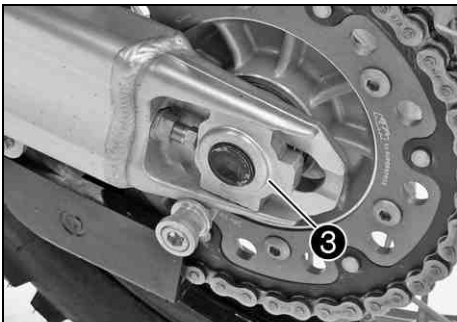

13.4 Installing the rear wheel

Warning
Danger of accidents Reduced braking efficiency due to oil or grease on the brake discs.
 – Always keep the brake discs free of oil and grease, and clean them with brake cleaner when necessary.



Main work

- Check the rear hub rubber dampers.  (☞ p. 70)
- Check the wheel bearing for damage and wear.
 - » If the wheel bearing is damaged or worn:
 - Change the wheel bearing. 
- Clean and grease the shaft seal rings and bearing surface of the spacer.

Long-life grease (☞ p. 118)
- Insert spacers ❶.
- Clean and grease the shaft seal rings and bearing surface of the spacer in the rear sprocket carrier.
- Insert the rear sprocket carrier ❷ into the rear hub.

- Lift the rear wheel into the swingarm, position it, and insert wheel spindle ❸.
- Attach the chain.
- Position chain adjuster ❹. Mount nut ❺, but do not tighten it yet.
- Check the chain tension. (☞ p. 52)
- Make sure that the chain adjusters are fitted correctly on the adjusting screws.
- Tighten nut ❺.

Guideline

Nut, rear wheel spindle	M25x1.5	90 Nm (66.4 lbf ft)
-------------------------	---------	------------------------

i Info
 The wide adjustment range of the chain adjusters enables different secondary ratios with the same chain length.
 The chain adjusters can be turned by 180°.

- Operate the foot brake lever repeatedly until the brake linings are in contact with the brake disc and there is a pressure point.

Finishing work

- Remove the motorcycle from the lift stand. (☞ p. 40)

13.5 Checking the rear hub rubber dampers

i Info
The engine power is transmitted from the rear sprocket to the rear wheel via 6 rubber dampers. They eventually wear out during operation. If the rubber dampers are not changed in time, the rear sprocket carrier and the rear hub will be damaged.

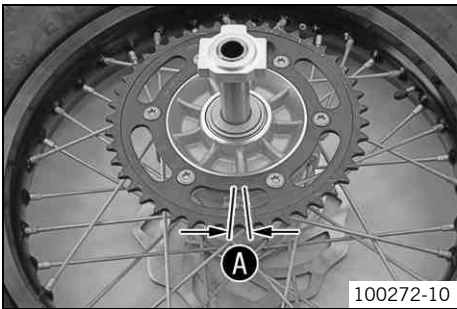
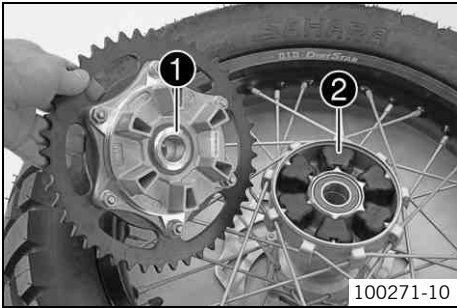

Preparatory work

- Raise the motorcycle with the lift stand. (☞ p. 40)
- Remove the rear wheel. (☞ p. 68)

Main work

- Check bearing ①.
 - » If the bearing is damaged or worn:
 - Change the bearing. (☞)
- Check rubber dampers ② of the rear hub for damage and wear.
 - » If the rubber dampers of the rear hub are damaged or worn:
 - Change all rubber dampers in the rear hub.

- Lay the rear wheel on a workbench with the rear sprocket facing upward and insert the wheel spindle in the hub.
- To check the play ④, hold the rear wheel tight and try to rotate the rear sprocket.

i Info
Measure the play on the outside of the rear sprocket.

Play in rubber dampers, rear wheel	≤ 5 mm (≤ 0.2 in)
------------------------------------	-------------------

- » If play ④ is larger than the specified value:
 - Change all rubber dampers in the rear hub.

Finishing work

- Install the rear wheel. (☞ p. 69)
- Remove the motorcycle from the lift stand. (☞ p. 40)

13.6 Checking the tire condition

i Info
Only mount tires approved and/or recommended by KTM.
Other tires could have a negative effect on riding behavior.
The type, condition and air pressure of the tires all have an important impact on the riding behavior of the motorcycle.
The tires mounted on the front and rear wheels must have a similar profile.
Worn tires have a negative effect on riding behavior, especially on wet surfaces.

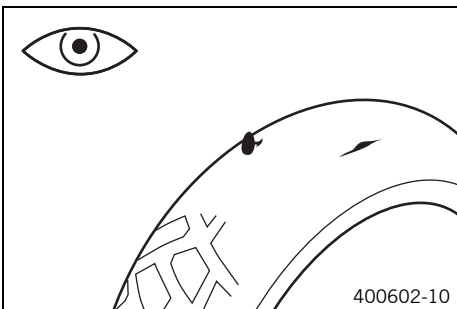

- Examine the front and rear tires for cuts, foreign bodies, and other damage.
 - » If you find cuts, foreign bodies, or other damage on a tire:
 - Change the tire.
- Check the depth of the tread.

i Info
Note local national regulations concerning the minimum tread depth.

Minimum tread depth	≥ 2 mm (≥ 0.08 in)
---------------------	--------------------

- » If the tread depth is less than the minimum allowable depth:
 - Change the tire.
- Check the tire age.



Info

The tire manufacture date is usually included in the tire identification number and comprises the last four digits of the **DOT** code. The first two digits indicate the week of manufacture and the last two digits the year of manufacture.

KTM recommends that the tires be changed after 5 years at the latest, regardless of the actual state of wear.

- » If the tire is older than five years:
 - Change the tire.

13.7 Checking the tire air pressure



Info

Low tire air pressure leads to abnormal wear and overheating of the tire. Correct tire air pressure ensures optimal riding comfort and maximum tire service life.

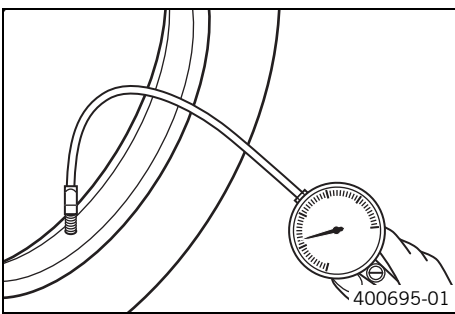

- Remove the dust cap.
- Check tire air pressure when tires are cold.

Tire air pressure off road	
Front	1.0... 1.5 bar (15... 22 psi)
Rear	1.0... 1.5 bar (15... 22 psi)

Tire air pressure on road	
Front	1.5 bar (22 psi)
Rear	1.5 bar (22 psi)

- » If the tire pressure does not meet specifications:
 - Correct the tire air pressure.
- Fit the dust cap.

13.8 Checking the spoke tension



Warning

Danger of accidents Instable handling due to incorrect spoke tension.

- Ensure that the spoke tension is correct. (Your authorized KTM workshop will be glad to help.)



Info

A loose spoke causes wheel imbalance and rapidly leads to more loose spokes. If the spokes are too tight, they can break due to local overload. Check the spoke tension regularly, especially on a new motorcycle.

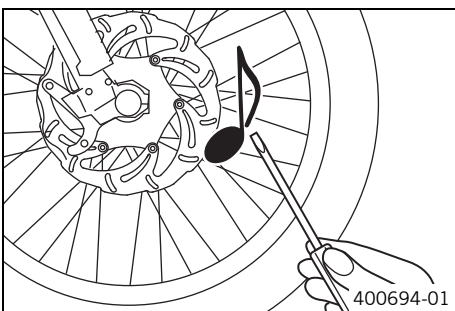

- Briefly strike each spoke with a screwdriver blade.



Info

The frequency of the tone is a function of the spoke length and spoke diameter.

If you hear different tone frequencies from individual spokes of the same length and thickness, this is an indication of different spoke tensions.

You should hear a high note.

- » If the spoke tensions differ:
 - Correct the spoke tension. 🛠️
- Check the spoke tension.

Guideline

Spoke nipple, front wheel	M4.5	5... 6 Nm (3.7... 4.4 lbf ft)
Spoke nipple, rear wheel	M5	5... 6 Nm (3.7... 4.4 lbf ft)

Torque wrench with various accessories in set (58429094000)

14.1 Removing the battery

Warning
Risk of injury Battery acid and battery gases cause serious chemical burns.

- Keep batteries out of the reach of children.
- Wear suitable protective clothing and goggles.
- Avoid contact with battery acid and battery gases.
- Keep the battery away from sparks or open flames. Charge only in well-ventilated areas.
- In the event of skin contact, rinse with large amounts of water. If battery acid gets in the eyes, rinse with water for at least 15 minutes and contact a physician.

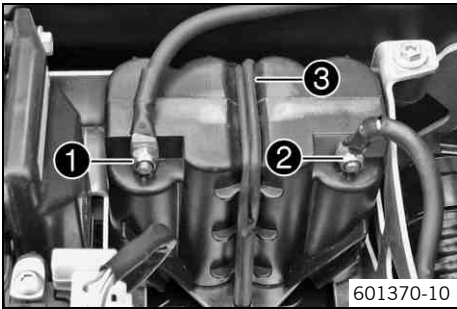

Preparatory work

- Switch off all power consumers and switch off the engine.
- Remove the seat. (☛ p. 48)

Main work

- Disconnect the negative (minus) cable ❶ of the battery.
- Disconnect the positive (plus) cable ❷ of the battery.
- Detach rubber band ❸ from the bottom.
- Lift the battery up and remove it.

14.2 Installing the battery

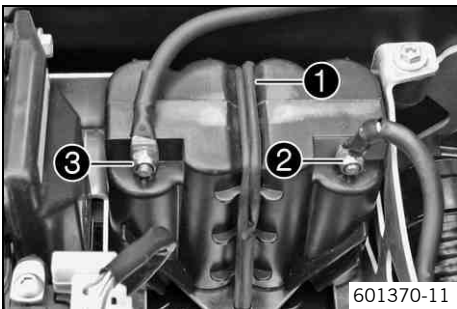

Main work

- Place the battery in the battery holder.

Lithium-ion battery (☛ p. 94)

- Reconnect rubber band ❶.
- Connect positive cable ❷.

Guideline

Nut, cable on battery	M6	5 Nm (3.7 lbf ft)
-----------------------	----	-------------------

- Attach negative cable ❸.

Guideline

Nut, cable on battery	M6	5 Nm (3.7 lbf ft)
-----------------------	----	-------------------

Finishing work

- Mount the seat. (☛ p. 48)

14.3 Recharging the battery

Warning
Environmental hazard The battery contains elements that are harmful to the environment.

- Do not discard batteries with the household trash. Dispose of a defective battery in an environmentally compatible manner. Give the battery to your KTM dealer or to a recycling center that accepts used batteries.

Info

Even when there is no load on the battery, it still loses power steadily. The charging voltage of the battery must not exceed 14.4 V. The charge state and the type of charge are very important for the service life of the battery. If the charging voltage is exceeded, the battery capacity will be reduced. If the battery is depleted from starting the vehicle repeatedly, the battery must be charged immediately.

Preparatory work

- Switch off all power consumers and switch off the engine.
- Remove the seat. (☛ p. 48)



- Disconnect the negative cable of the battery to avoid damage to the onboard electronics.

Main work

- Connect the battery charger to the battery. Switch on the battery charger.

Battery charger (58429074000)

You can also use the battery charger to test the open-circuit voltage and starting voltage of the battery, and to test the alternator. With this device, you cannot over-charge the battery.

i Info

Only charge the battery with the specified battery charge. This is the only way to ensure that a charging voltage of 14.4 V is not exceeded.

- Switch off the battery charger after charging. Disconnect the battery.

Finishing work

- Mount the seat. (☛ p. 48)

14.4 Changing the main fuse

Warning

Fire hazard The electrical system can be overloaded if the wrong fuses are used.

- Use only fuses with the prescribed amperage. Never by-pass or repair fuses.

i Info

The main fuse protects all power consumers of the vehicle. It is located in the starter relay housing under the seat.

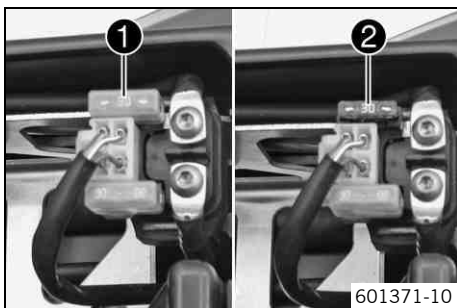

Preparatory work

- Switch off all power consumers and switch off the engine.
- Remove the seat. (☛ p. 48)

Main work

- Remove protection cap ❶.
- Remove the faulty main fuse ❷.

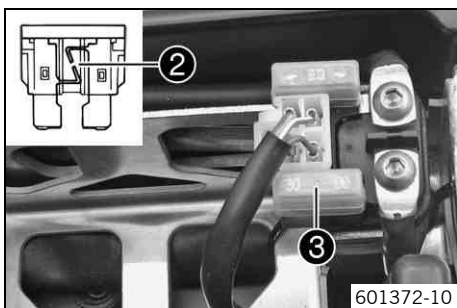

- Fit a new main fuse.

Fuse (58011109130) (☛ p. 94)

i Info

Replace a faulty fuse ❷ by an equivalent fuse only. A reserve fuse ❸ is located in the starter relay.

- Check that the electrical equipment is functioning properly.

i Tip

Insert the spare fuse so that it is available if needed.

- Attach the protection caps.

Finishing work

- Mount the seat. (☛ p. 48)

14.5 Changing fuses of individual power consumers

i Info
The fuse box containing the fuses of individual power consumers is located under the seat.

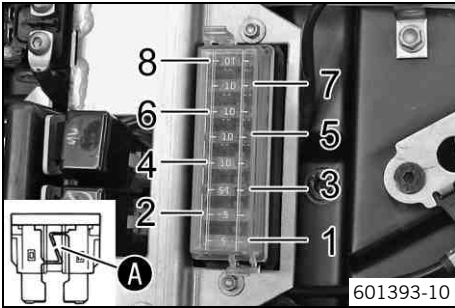

Preparatory work

- Switch off all power consumers and switch off the engine.
- Remove the seat. (☛ p. 48)

Main work

- Open the fuse box cover.
- Remove the defective fuse.

Guideline

Fuse 1 - 5 A - for auxiliary equipment (accessories connected to the ignition switch)
Fuse 2 - 5 A - for auxiliary equipment (permanent positive)
Fuse 3 - 15 A - high beam, low beam, parking light, tail light, license plate lamp, speedometer, horn
Fuse 4 - 10 A - for auxiliary equipment (permanent positive)
Fuse 5 - 10 A - for auxiliary equipment (accessories connected to the ignition switch)
Fuse 6 - 10 A - brake light, turn signal
Fuse 7 - 10 A - radiator fan
Fuse 8 - 10 A - CDI controller

i Info
A defective fuse is shown by a burned-out fuse wire **A**.

! Warning
Fire hazard The electrical system can be overloaded if the wrong fuses are used.

- Use only fuses with the prescribed amperage. Never by-pass or repair fuses.

- Use spare fuses with the correct rating only.

Fuse (58011109105) (☛ p. 94)
Fuse (58011109110) (☛ p. 94)
Fuse (58011109115) (☛ p. 94)

- Check that the power consumer is functioning properly.
- Close the fuse box cover.

Finishing work

- Mount the seat. (☛ p. 48)

14.6 Checking the headlight setting

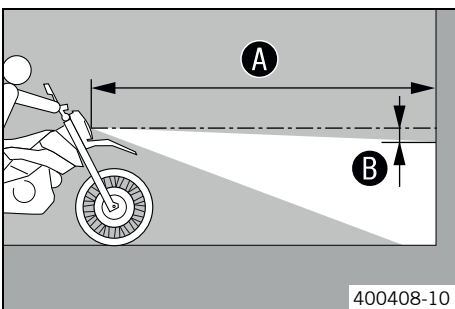

- Position the vehicle upright on a horizontal surface in front of a light wall and make a mark at the height of the center of the low beam headlight.
- Make another mark a distance **B** under the first mark.

Guideline

Distance B	5 cm (2 in)
-------------------	-------------

- Position the vehicle vertically a distance **A** away from the wall.

Guideline

Distance A	5 m (16 ft)
-------------------	-------------

- The rider now sits down on the motorcycle.
- Switch on the low beam.
- Check the headlight setting.

The boundary between light and dark must be exactly on the lower mark for a motorcycle with driver.

- » If the boundary between light and dark does not meet specifications:
 - Adjust the headlight range. (🔧 p. 76)

14.7 Adjusting the headlight range

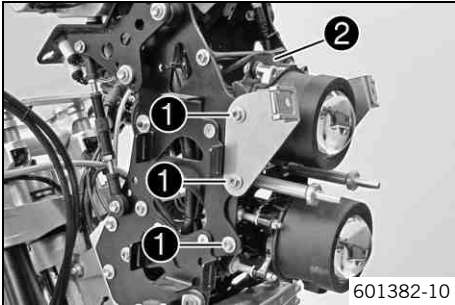

Preparatory work

- Check the headlight setting. (🔧 p. 75)
- Remove the trim. (🔧 p. 57)

Main work

- Loosen screw ❶.
- Adjust the headlight range by moving the headlight.

Guideline

The boundary between light and dark must be exactly on the lower mark for an operational motorcycle with a rider (to prepare the mark, see: Checking the headlight setting).



Info

A change in weight on the vehicle may require a correction of the headlight range.

- Tighten screw ❶.

Finishing work

- Mount the trim. (🔧 p. 57)

15.1 Cooling system

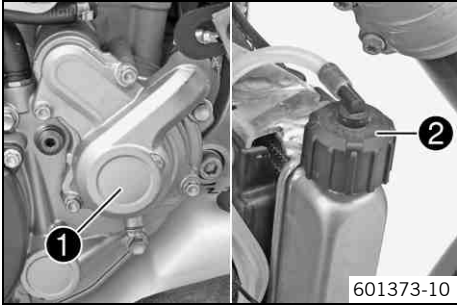

Water pump ❶ in the engine circulates the coolant. The pressure resulting from the warming of the cooling system is regulated by a valve in radiator cap ❷. This ensures that operating the vehicle at the specified coolant temperature will not result in a risk of malfunctions.

120 °C (248 °F)

Cooling is effected by the air stream. The lower the speed, the less the cooling effect. Dirty cooling fins also reduce the cooling effect. The radiator fan provides extra cooling. It is controlled by a thermostat.

15.2 Checking the antifreeze and coolant level

Warning
Danger of scalding During motorcycle operation, the coolant gets very hot and is under pressure.

- Do not remove the radiator cap, radiator hoses or other cooling system components when the engine is hot. Allow the engine and cooling system to cool down. In case of scalding, rinse immediately with lukewarm water.

Warning
Danger of poisoning Coolant is poisonous and a health hazard.

- Avoid contact between coolant and skin, eyes and clothing. If it gets into your eyes, rinse immediately with water and contact a doctor. Wash affected skin areas immediately with soap and water. If coolant is swallowed, contact a doctor immediately. Change clothes that have come into contact with coolants. Keep coolant out of the reach of children.

Condition
 The engine is cold.

- Stand the motorcycle upright on a horizontal surface.
- Remove the radiator cap.
- Check the coolant antifreeze.

-25... -45 °C (-13... -49 °F)

- » If the coolant antifreeze does not meet specifications:
 - Correct the coolant antifreeze.

- Check the coolant level in the radiator.

Coolant level ❶ above the radiator fins.	10 mm (0.39 in)
--	-----------------

- » If the coolant level does not meet specifications:
 - Correct the coolant level.

Alternative 1

Coolant (☞ p. 116)

Alternative 2

Coolant (mixed ready to use) (☞ p. 116)

- Mount the radiator cap.

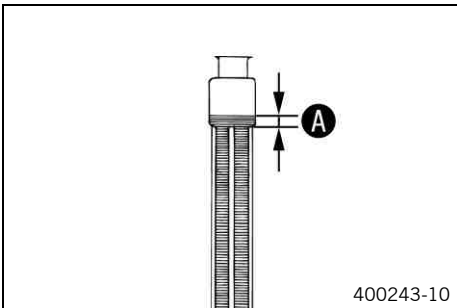

15.3 Checking the coolant level

Warning
Danger of scalding During motorcycle operation, the coolant gets very hot and is under pressure.

- Do not remove the radiator cap, radiator hoses or other cooling system components when the engine is hot. Allow the engine and cooling system to cool down. In case of scalding, rinse immediately with lukewarm water.

Warning
Danger of poisoning Coolant is poisonous and a health hazard.

- Avoid contact between coolant and skin, eyes and clothing. If it gets into your eyes, rinse immediately with water and contact a doctor. Wash affected skin areas immediately with soap and water. If coolant is swallowed, contact a doctor immediately. Change clothes that have come into contact with coolants. Keep coolant out of the reach of children.

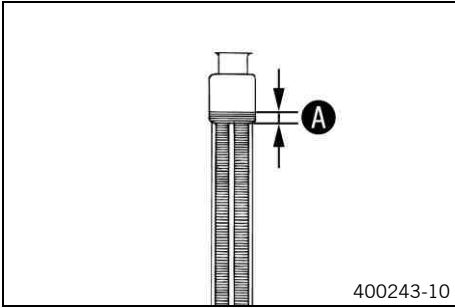

Condition

The engine is cold.

- Stand the motorcycle upright on a horizontal surface.
- Remove the radiator cap.
- Check the coolant level in the radiator.

Coolant level A above the radiator fins.	10 mm (0.39 in)
---	-----------------

- » If the coolant level does not meet specifications:
 - Correct the coolant level.

Alternative 1

Coolant (☛ p. 116)

Alternative 2

Coolant (mixed ready to use) (☛ p. 116)

- Mount the radiator cap.

15.4 Draining the coolant ☛



Warning

Danger of scalding During motorcycle operation, the coolant gets very hot and is under pressure.

- Do not remove the radiator cap, radiator hoses or other cooling system components when the engine is hot. Allow the engine and cooling system to cool down. In case of scalding, rinse immediately with lukewarm water.



Warning

Danger of poisoning Coolant is poisonous and a health hazard.

- Avoid contact between coolant and skin, eyes and clothing. If it gets into your eyes, rinse immediately with water and contact a doctor. Wash affected skin areas immediately with soap and water. If coolant is swallowed, contact a doctor immediately. Change clothes that have come into contact with coolants. Keep coolant out of the reach of children.

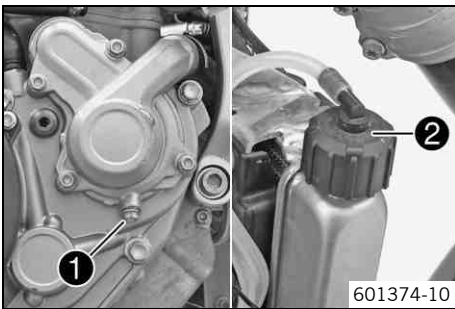

Condition

The engine is cold.

- Stand the motorcycle upright.
- Place a suitable container under the water pump cover.
- Remove screw **1**. Remove radiator cap **2**.
- Completely drain the coolant.
- Mount and tighten screw **1** with a new seal ring.

Guideline

Screw, water pump cover	M6	10 Nm (7.4 lbf ft)
-------------------------	----	--------------------

15.5 Refilling coolant ☛



Warning

Danger of poisoning Coolant is poisonous and a health hazard.

- Avoid contact between coolant and skin, eyes and clothing. If it gets into your eyes, rinse immediately with water and contact a doctor. Wash affected skin areas immediately with soap and water. If coolant is swallowed, contact a doctor immediately. Change clothes that have come into contact with coolants. Keep coolant out of the reach of children.

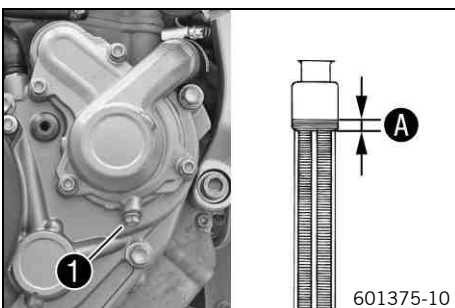

- Make sure that screw **1** is tightened.
- Stand the motorcycle upright.
- Pour coolant in up to measurement **A** above the radiator fins.

Guideline

Coolant level A above the radiator fins	10 mm (0.39 in)
--	-----------------

Coolant	1.2 l (1.3 qt.)	Coolant (☛ p. 116)
		Coolant (mixed ready to use) (☛ p. 116)

- Mount the radiator cap.
- Take a short test ride.
- Check the coolant level. (☛ p. 77)

16.1 Checking the play in the throttle cable

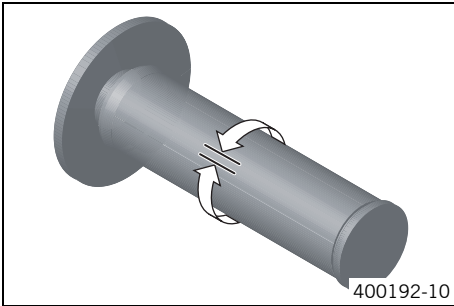

- Check the throttle grip for smooth operation.
- Move the handlebar to the straight-ahead position. Move the throttle grip backwards and forwards to ascertain the play in the throttle cable.

Play in throttle cable	3... 5 mm (0.12... 0.2 in)
------------------------	----------------------------

- » If the throttle cable play does not meet specifications:
 - Adjust the play in the throttle cable. (🔧 p. 80)



Danger

Danger of poisoning Exhaust gases are toxic and inhaling them may result in unconsciousness and/or death.

- When running the engine, always make sure there is sufficient ventilation, and do not start or run the engine in an enclosed space without an effective exhaust extraction system.

- Start the engine and let it run idle. Move the handlebar to and fro over the entire steering range.

The idle speed must not change.

- » If the idle speed changes:
 - Adjust the play in the throttle cable. (🔧 p. 80)

16.2 Adjusting the play in the throttle cable 🛠️

Preparatory work

- Remove the trim. (🔧 p. 57)
- Remove the seat. (🔧 p. 48)
- Remove the fuel tank toward the front. (🔧 p. 50)
- Check the throttle cable routing.

Main work

- Move the handlebar to the straight-ahead position.
- Push back sleeves ❶.
- Loosen nut ❷. Turn adjusting screw ❸ in as far as possible.
- Loosen nut ❹. Turn adjusting screw ❺ so that there is play in the throttle cable at the throttle grip.

Guideline

Play in throttle cable	3... 5 mm (0.12... 0.2 in)
------------------------	----------------------------

- Tighten nut ❹.
- Press and hold the throttle grip in the closed setting. Turn out adjusting screw ❸ until there is no play in the upper throttle cable.
- Tighten nut ❷.
- Push sleeves ❶ on. Check the throttle grip for smooth operation.

Finishing work

- Install the fuel tank at the front. (🔧 p. 51)
- Mount the seat. (🔧 p. 48)
- Mount the trim. (🔧 p. 57)
- Check the play in the throttle cable. (🔧 p. 80)

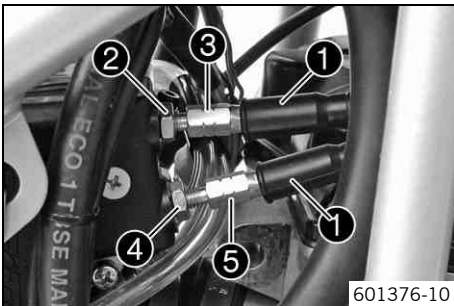

16.3 Carburetor - idle

The idle setting of the carburetor has a big influence on the starting behavior, stable idling, and the response to throttle opening. That means that an engine with a correctly set idle speed is easier to start than if the idle is set wrongly.



Info

The carburetor and its components are subject to increased wear caused by engine vibration. Wear can result in malfunctioning.



The idle mixture is adjusted with the idle adjusting screw ❶.

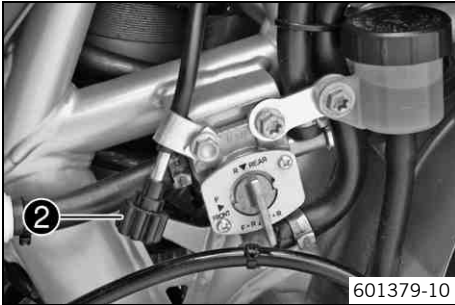

The idle speed is adjusted with adjusting screw ❷.

16.4 Carburetor - adjusting the idle speed



- Screw in idle adjusting screw ❶ until it stops and then to the prescribed basic setting.

Guideline

Idle mixture adjusting screw	
Open	1.5 turns

- Run the engine until warm.

Guideline

Warm-up time	≥ 5 min
--------------	---------



Danger

Danger of poisoning Exhaust gases are toxic and inhaling them may result in unconsciousness and/or death.

- When running the engine, always make sure there is sufficient ventilation, and do not start or run the engine in an enclosed space without an effective exhaust extraction system.

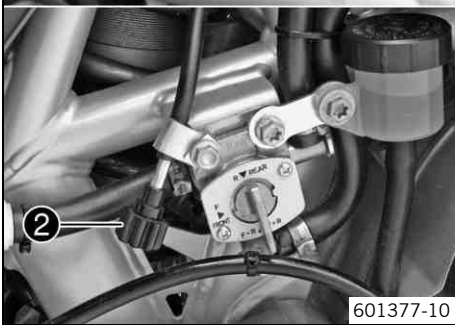

- Adjust the idle speed with adjusting screw ❷.

Guideline

Choke function deactivated – The choke lever is pushed back to the stop. (☛ p. 21)	
Idle speed	1,550... 1,650 rpm

- Turn idle adjusting screw ❶ slowly clockwise until the idle speed begins to fall.
- Note the position and turn the idle adjusting screw slowly counterclockwise until the idle speed falls.
- Adjust to the point between these two positions with the highest idle speed.



Info

If there is a big engine speed rise, reduce the idle speed to a normal level and repeat the above steps.

The extreme sport motorcyclist will set the mixture about ¼ of a turn back from this ideal value (leaner, in a clockwise direction) since the engine becomes hotter in sporting use.

If the procedure described here does not lead to satisfactory results, the cause may be a wrongly dimensioned idling jet.

If you can turn the idle adjusting screw to the end without any change of engine speed, you have to fit a smaller idling jet.

The idle adjusting screw must not be opened more than two turns. If more than two turns are necessary (rich mixture), use a larger idling jet.

After changing the idling jet, start from the beginning with the adjusting steps.

- Adjust the idle speed with adjusting screw ②.

Guideline

Choke function deactivated – The choke lever is pushed back to the stop. (☞ p. 21)	
Idle speed	1,550... 1,650 rpm



Info

Following extreme air temperature or altitude changes, adjust the idle speed again.

16.5 Emptying the carburetor float chamber ☞



Danger

Fire hazard Fuel is highly flammable.

- Never refuel the vehicle near open flames or burning cigarettes, and always switch off the engine first. Be careful that no fuel is spilt, especially on hot vehicle components. Clean up spilt fuel immediately.
- Fuel in the fuel tank expands when warm and can escape if the tank is overfilled. See the notes on refueling.



Warning

Danger of poisoning Fuel is poisonous and a health hazard.

- Avoid contact between fuel and skin, eyes and clothing. Do not inhale fuel vapors. If fuel gets into your eyes, rinse immediately with water and contact a doctor. Wash affected skin areas immediately with soap and water. If fuel is swallowed, contact a doctor immediately. Change clothing that has come into contact with fuel. Store fuel in a suitable canister according to regulations and keep it out of the reach of children.



Warning

Environmental hazard Improper handling of fuel is a danger to the environment.

- Do not allow fuel to get into the ground water, the ground, or the sewage system.



Info

Carry out this work with a cold engine.



601378-11

- Direct the hose of the float chamber into a suitable container.



Info

Water in the float chamber results in malfunctioning.

- Loosen screw ① by several turns.
✓ The fuel drains out of the float chamber.
- Tighten screw ①.

16.6 Checking the basic position of the shift lever

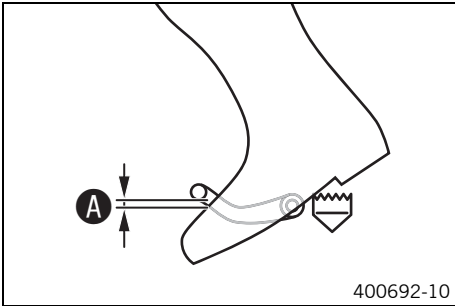

- Sit on the vehicle in the riding position and determine distance **A** between the upper edge of your boot and the shift lever.

Distance between shift lever and upper edge of boot	10... 20 mm (0.39... 0.79 in)
---	-------------------------------

- » If the distance does not meet specifications:
 - Adjust the basic position of the shift lever. (p. 83)

16.7 Adjusting the basic position of the shift lever

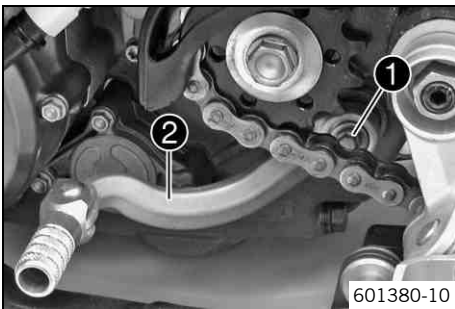

- Remove screw **1** and take off shift lever **2**.

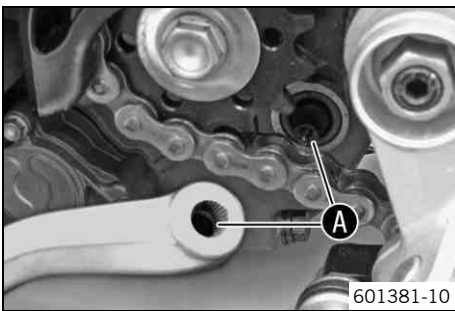

- Clean gear teeth **A** of the shift lever and shift shaft.
- Mount the shift lever on the shift shaft in the required position and engage the gearing.

i Info
 The range of adjustment is limited.
 The shift lever must not come into contact with any other vehicle components during the shift procedure.

- Mount and tighten the screw.

Guideline

Screw, shift lever	M6	14 Nm (10.3 lbf ft)	Loctite® 243™
--------------------	----	------------------------	---------------

17.1 Checking the engine oil level

i Info
The engine oil level can be checked when the engine is cold or warm.

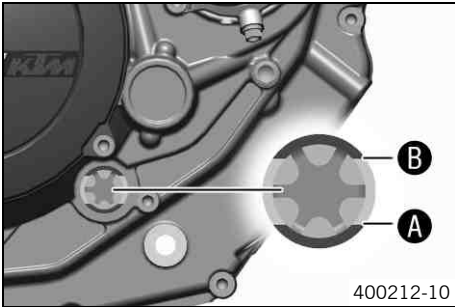

Preparatory work

- The motorcycle is positioned on a horizontal surface.

Condition

The engine is cold.

- Check the engine oil level.

The engine oil level is up to the bottom edge **A** of the level viewer.

- » If the engine oil is not up to the bottom edge of the level viewer:
 - Add engine oil. (☛ p. 86)

Condition

The engine is at normal operating temperature.

- Check the engine oil level.

i Info
After switching off the engine, wait a minute and then check.

The engine oil level is up to the top edge of the level viewer **B**.

- » If the engine oil is not up to the top edge of the level viewer:
 - Add engine oil. (☛ p. 86)

17.2 Changing the engine oil and oil filter, cleaning the oil screen

⚠ Warning
Danger of scalding Engine oil and gear oil get very hot when the motorcycle is ridden.

- Wear appropriate protective clothing and safety gloves. In case of burns, rinse immediately with lukewarm water.

🌿 Warning
Environmental hazard Hazardous substances cause environmental damage.

- Oil, grease, filters, fuel, cleaners, brake fluid, etc., should be disposed of as stipulated in applicable regulations.

i Info
Drain the engine oil only when the engine is warm.

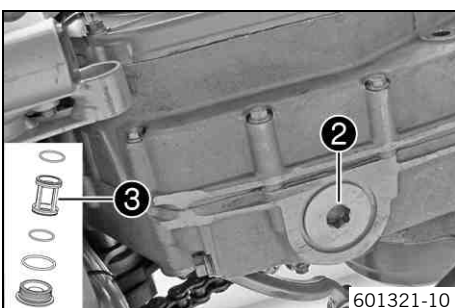
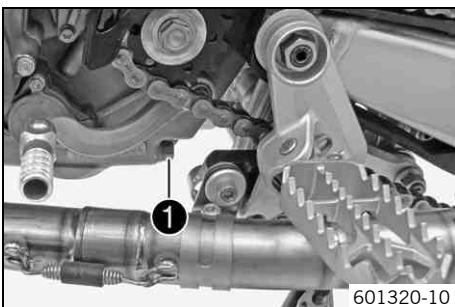

Preparatory work

- Park the motorcycle on a level surface.

Main work

- Place a suitable container under the engine.
- Remove oil drain plug **1** with the seal ring.

- Loosen screw plug **2** by striking it lightly with a hammer a few times.
- Remove plug **2** with oil screen **3** and the O-rings.
- Completely drain the engine oil.
- Thoroughly clean the parts and sealing surfaces.
- Mount and tighten screw plug **2** with oil screen **3** and the O-rings.

Guideline

Plug, oil screen	M32x1.5	30 Nm (22.1 lbf ft)	Lubricated with engine oil
------------------	---------	------------------------	----------------------------

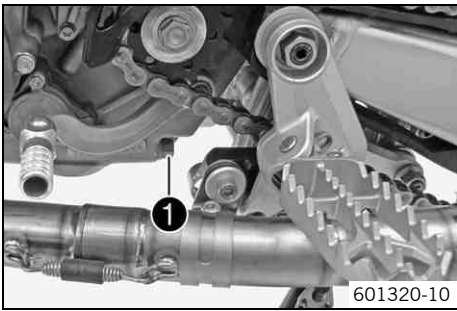

- Mount and tighten oil drain plug **1** with the seal ring.

Guideline

Oil drain plug with magnet	M12x1.5	20 Nm (14.8 lbf ft)
----------------------------	---------	------------------------

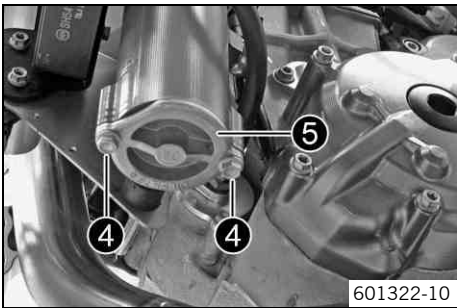

- Remove screws **4**. Remove the lower oil filter cover **5** with the O-ring.

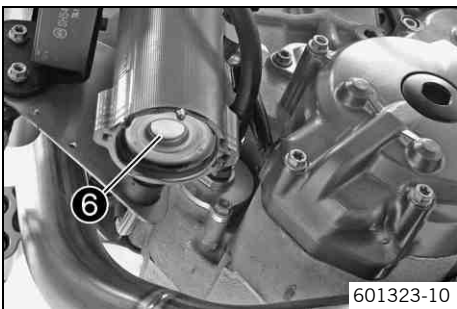

- Pull oil filter **6** out of the oil filter housing.

Circlip pliers reverse (51012011000)

- Completely drain the engine oil.
- Thoroughly clean the parts and sealing area.



- Oil O-ring **7** and mount on the oil filter cover.

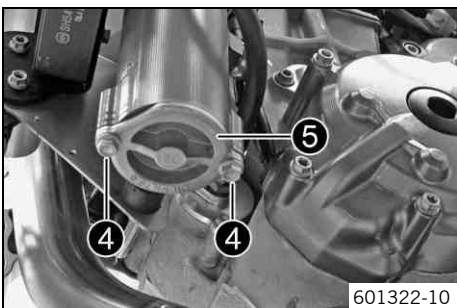

- Position the lower oil filter cover **5**. Mount and tighten screws **4**.

Guideline

Screw, oil filter cover	M5	6 Nm (4.4 lbf ft)
-------------------------	----	-------------------

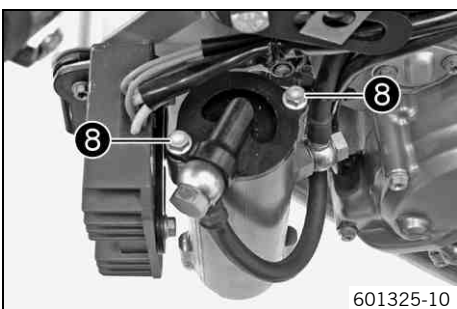

- Remove screws **8**. Remove the upper oil filter cover with the O-ring.

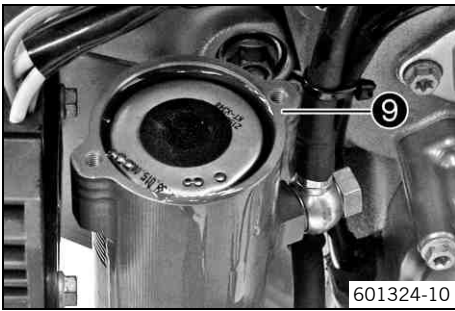

- Fill the oil filter housing 9 with oil and wait until air bubbles stop rising.

Engine oil (SAE 10W/60) (00062010035) (☛ p. 116)
Engine oil (SAE 10W/50) (☛ p. 116)

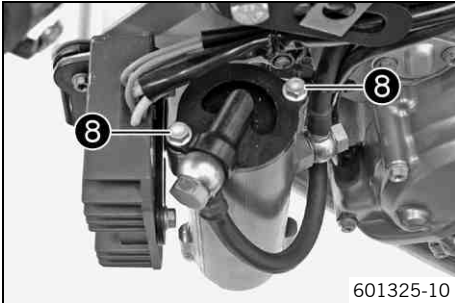

- Position the upper oil filter cover. Mount and tighten screws 8.

Guideline

Screw, oil filter cover	M5	6 Nm (4.4 lbf ft)
-------------------------	----	-------------------

- Wipe away excess engine oil.



- Remove the oil filler plug 10 on the clutch cover and fill up with engine oil.

Engine oil		
Oil change	1.20 l (1.27 qt.)	Engine oil (SAE 10W/60) (00062010035) (☛ p. 116)
		Engine oil (SAE 10W/50) (☛ p. 116)

i Info
Too little engine oil or poor-quality engine oil results in premature wear of the engine.

- Mount and tighten the oil filler plug.

! Danger
Danger of poisoning Exhaust gases are toxic and inhaling them may result in unconsciousness and/or death.

- When running the engine, always make sure there is sufficient ventilation, and do not start or run the engine in an enclosed space without an effective exhaust extraction system.

- Start the engine and check that it is oil-tight.

Finishing work

- Check the engine oil level. (☛ p. 84)

17.3 Adding engine oil

i Info
Too little engine oil or poor-quality engine oil results in premature wear to the engine.



Main work

- Remove the oil filler plug 1 on the clutch cover and fill up with engine oil.

Engine oil (SAE 10W/60) (00062010035) (☛ p. 116)
Engine oil (SAE 10W/50) (☛ p. 116)

i Info
For optimal performance of the engine oil, do not mix different types of engine oil.
We recommend making an oil change in this case.

- Mount and tighten the oil filler plug.

**Danger**

Danger of poisoning Exhaust gases are toxic and inhaling them may result in unconsciousness and/or death.

- When running the engine, always make sure there is sufficient ventilation, and do not start or run the engine in an enclosed space without an effective exhaust extraction system.

-
- Start the engine and check that it is oil-tight.

Finishing work

- Check the engine oil level. (🔧 p. 84)

18.1 Cleaning motorcycle

Note

Material damage Damage and destruction of components by high-pressure cleaning equipment.

- When cleaning the vehicle with a pressure cleaner, do not point the water jet directly onto electrical components, connectors, cables, bearings, etc. Maintain a minimum distance of 60 cm between the nozzle of the pressure cleaner and the component. Excessive pressure can cause malfunctions or destroy these parts.

 **Warning**

Environmental hazard Hazardous substances cause environmental damage.

- Oil, grease, filters, fuel, cleaners, brake fluid, etc., should be disposed of as stipulated in applicable regulations.

 **Info**

If you clean the motorcycle regularly, its value and appearance will be maintained over a long period. Avoid direct sunshine on the motorcycle during cleaning.

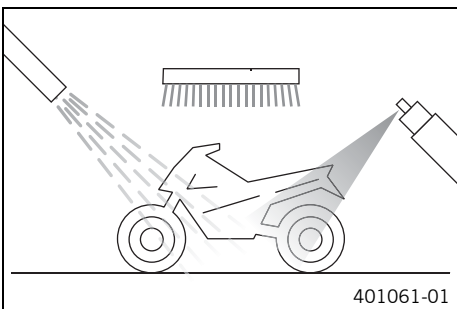

- Seal the exhaust system to keep water out.
- First remove coarse dirt particles with a gentle water spray.
- Spray very dirty areas with a normal motorcycle cleaner and then clean with a paintbrush.

Motorcycle cleaner (☛ p. 118)

 **Info**

Use warm water containing normal motorcycle cleaner and a soft sponge.

- After rinsing the motorcycle with a gentle spray of water, allow it to dry thoroughly.
- Remove the closure on the exhaust system.



Warning

Danger of accidents Reduced braking efficiency due to a wet or dirty brake system.

- Clean or dry a dirty or wet brake system by riding and braking gently.

- After cleaning, ride a short distance until the engine reaches operating temperature.

 **Info**

The heat produced causes water at inaccessible locations in the engine and the brake system to evaporate.

- After the motorcycle has cooled off, lubricate all moving parts and bearings.
- Clean the chain. (☛ p. 52)
- Empty the carburetor float chamber. ☛ (☛ p. 82)
- Treat bare metal parts (except for brake discs and exhaust system) with anti-corrosion materials.

Cleaning and preserving materials for metal, rubber and plastic (☛ p. 118)

- Treat all plastic parts and powder-coated parts with a mild cleaning and care products.

Paint cleaner and polish for high-gloss and matte finishes, bare metal and plastic surfaces (☛ p. 118)

- Oil the steering lock.

Universal oil spray (☛ p. 119)

18.2 Checks and maintenance steps for winter operation

- i Info**
If you use the motorcycle in winter, you can expect salt on the roads. Precautions need to be taken against the aggressive road salt.
If the vehicle was operated in road salt, clean it with cold water after riding. Warm water would enhance the corrosive effects of salt.

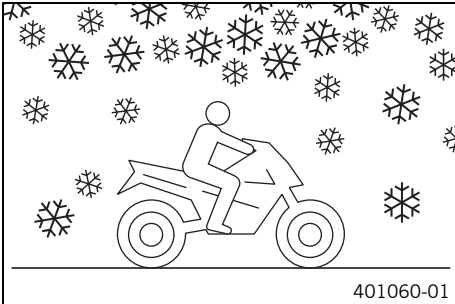

- Clean the motorcycle. (☛ p. 88)
- Clean the brake system.

- i Info**
After **EVERY** trip on salted roads, thoroughly wash the brake calipers and brake linings with cold water and dry carefully. This should be done after the parts are cooled down and while they are installed.
After riding on salted roads, thoroughly wash the motorcycle with cold water and dry it well.

- Treat the engine, swingarm, and all other bright and zinc-plated parts (except for the brake discs) with a wax-based corrosion inhibitor.

- i Info**
Corrosion inhibitor is not permitted to come in contact with the brake discs as this would greatly reduce the braking force.

- Clean the chain. (☛ p. 52)

19.1 Storage

Warning
Danger of poisoning Fuel is poisonous and a health hazard.

- Avoid contact between fuel and skin, eyes and clothing. Do not inhale fuel vapors. If fuel gets into your eyes, rinse immediately with water and contact a doctor. Wash affected skin areas immediately with soap and water. If fuel is swallowed, contact a doctor immediately. Change clothing that has come into contact with fuel. Store fuel in a suitable canister according to regulations and keep it out of the reach of children.

Info
 If you want to garage the motorcycle for a longer period, take the following actions. Before storing the motorcycle, check all parts for function and wear. If service, repairs or replacements are necessary, you should do this during the storage period (less workshop overload). In this way, you can avoid long workshop waiting times at the start of the new season.

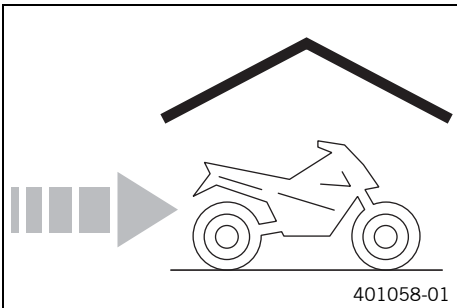

- Clean the motorcycle. (☞ p. 88)
- Change the engine oil and oil filter, clean the oil screen. 🛠️ (☞ p. 84)
- Check the antifreeze and coolant level. (☞ p. 77)
- Add fuel additive the last time you refuel before taking the motorcycle out of service.

Fuel additive (☞ p. 118)

- Drain the fuel from the fuel tanks into a suitable container.
- Empty the carburetor float chamber. 🛠️ (☞ p. 82)
- Check the tire air pressure. (☞ p. 71)
- Remove the battery. 🛠️ (☞ p. 73)
- Recharge the battery. 🛠️ (☞ p. 73)

Guideline

Storage temperature of battery without direct sunshine	0... 35 °C (32... 95 °F)
Charging level of the battery for storage	50... 75 %

- Place the vehicle on a dry storage place that is not subject to large temperature variations.

Info
 KTM recommends raising the motorcycle.

- Raise the motorcycle with the lift stand. (☞ p. 40)
- Cover the vehicle with an air-permeable cover or blanket.

Info
 Do not use non-porous materials since they prevent humidity from escaping, thus causing corrosion.
 Avoid running the engine for a short time only. Because the engine will not warm up sufficiently, the water vapor produced during combustion will condense, causing engine parts and the exhaust system to rust.

19.2 Preparing for use after storage

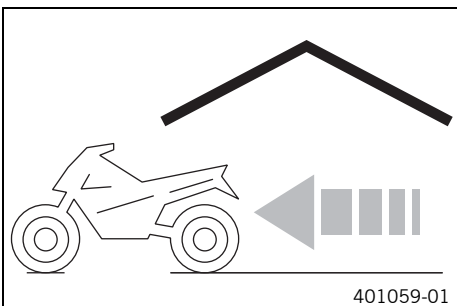

- Remove the motorcycle from the lift stand. (☞ p. 40)
- Install the battery. 🛠️ (☞ p. 73)
- Fill up with fuel. (☞ p. 29)
- Perform checks and maintenance steps when preparing for use. (☞ p. 26)
- Take a test ride.

20.1 Engine

Design	1-cylinder 4-stroke engine, water-cooled
Displacement	449.3 cm ³ (27.418 cu in)
Stroke	60.8 mm (2.394 in)
Bore	97 mm (3.82 in)
Compression ratio	12.5:1
Idle speed	1,550... 1,650 rpm
Control	DOHC, four valves controlled via cam lever, drive via helical gear pair and tooth-wheel chain
Valve diameter, intake	40.4 mm (1.591 in)
Valve diameter, exhaust	31.7 mm (1.248 in)
Valve clearance, cold, intake	0.10... 0.15 mm (0.0039... 0.0059 in)
Valve clearance, cold, exhaust	0.15... 0.20 mm (0.0059... 0.0079 in)
Crankshaft bearing	2 cylinder roller bearing
Conrod bearing	Needle bearing
Piston pin bearing	No bearing bush - piston pin made of TiAl alloy with DLC coating
Pistons	Forged light alloy
Engine lubrication	Pressure circulation lubrication with 3 rotor pumps
Primary transmission	29:74
Clutch	Multidisc clutch in oil bath/hydraulically activated
Transmission ratio	
1st gear	14:35
2nd gear	17:33
3rd gear	19:30
4th gear	21:28
5th gear	23:26
Alternator	12 V, 200 W
Ignition	Contactless controlled fully electronic ignition with digital ignition adjustment
Spark plug	NGK CR 9 EKB
Spark plug electrode gap	0.7 mm (0.028 in)
Cooling	Water cooling, permanent circulation of coolant by water pump
Starting aid	Electric starter

20.2 Engine tightening torques

Jet, engine case breather	M4	On block	Loctite® 243™
Oil jet, cam lever lubrication	M4	6 Nm (4.4 lbf ft)	Loctite® 243™
Oil jet, piston cooling	M4	4 Nm (3 lbf ft)	Loctite® 243™
Locking screw for bearing	M5	6 Nm (4.4 lbf ft)	Loctite® 243™
Oil jet, clutch oil supply	M5	6 Nm (4.4 lbf ft)	Loctite® 243™
Screw, bearing bolt of oil pump idler shaft	M5	6 Nm (4.4 lbf ft)	Loctite® 243™
Screw, camshaft bearing retaining bracket	M5	6 Nm (4.4 lbf ft)	Loctite® 243™
Screw, ignition pulse generator	M5	6 Nm (4.4 lbf ft)	Loctite® 243™
Screw, ignition pulse generator adapter	M5	6 Nm (4.4 lbf ft)	Loctite® 243™
Screw, locking lever	M5	6 Nm (4.4 lbf ft)	Loctite® 243™
Screw, oil filter cover	M5	6 Nm (4.4 lbf ft)	–
Screw, oil pump cover	M5	6 Nm (4.4 lbf ft)	Loctite® 243™
Screw, stator bracket	M5	6 Nm (4.4 lbf ft)	Loctite® 243™

Screw, stator cable holder	M5	6 Nm (4.4 lbf ft)	Loctite® 243™
Screw, timing train axle retaining bracket	M5	6 Nm (4.4 lbf ft)	Loctite® 243™
Nut, cylinder head	M6	10 Nm (7.4 lbf ft)	Lubricated with engine oil
Nut, water-pump wheel	M6	6 Nm (4.4 lbf ft)	Loctite® 243™
Oil jet, timing chain tensioner	M6	6 Nm (4.4 lbf ft)	Loctite® 243™
Screw, alternator cover	M6	10 Nm (7.4 lbf ft)	–
Screw, clutch cover	M6	10 Nm (7.4 lbf ft)	–
Screw, clutch slave cylinder	M6	10 Nm (7.4 lbf ft)	–
Screw, clutch spring	M6	10 Nm (7.4 lbf ft)	–
Screw, engine case	M6	10 Nm (7.4 lbf ft)	–
Screw, exhaust flange	M6	10 Nm (7.4 lbf ft)	Loctite® 243™
Screw, ignition pulse generator cable holder	M6	10 Nm (7.4 lbf ft)	Loctite® 243™
Screw, oil pump casing	M6	10 Nm (7.4 lbf ft)	Loctite® 243™
Screw, shift drum locating	M6	10 Nm (7.4 lbf ft)	Loctite® 243™
Screw, shift lever	M6	14 Nm (10.3 lbf ft)	Loctite® 243™
Screw, starter motor	M6	10 Nm (7.4 lbf ft)	–
Screw, valve cover	M6	8 Nm (5.9 lbf ft)	–
Screw, water pump cover	M6	10 Nm (7.4 lbf ft)	–
Stud, cylinder head	M6	10 Nm (7.4 lbf ft)	–
Screw, camshaft bearing bridge	M7x1	14 Nm (10.3 lbf ft)	Lubricated with engine oil
Screw, clutch cover	M7x1	14 Nm (10.3 lbf ft)	–
Screw, engine case	M7x1	14 Nm (10.3 lbf ft)	–
Plug, crankshaft location	M8	20 Nm (14.8 lbf ft)	–
Screw, engine sprocket	M10	60 Nm (44.3 lbf ft)	Loctite® 2701
Spark plug	M10	10... 12 Nm (7.4... 8.9 lbf ft)	–
Plug, cam lever axle	M10x1	10 Nm (7.4 lbf ft)	–
Plug, oil channel	M10x1	10 Nm (7.4 lbf ft)	–
Screw, camshaft gear	M10x1	50 Nm (36.9 lbf ft)	Lubricated with engine oil
Screw, rotor	M10x1	80 Nm (59 lbf ft)	Lubricated with engine oil
Screw, unlocking of timing chain tensioner	M10x1	10 Nm (7.4 lbf ft)	–
Nut, cylinder head	M10x1.25	Tightening sequence: Tighten in diagonal sequence. Tightening stage 1 10 Nm (7.4 lbf ft) Tightening stage 2 30 Nm (22.1 lbf ft) Tightening stage 3 50°	Lubricated with engine oil
Stud, cylinder head	M10x1.25	20 Nm (14.8 lbf ft)	–
Oil drain plug with magnet	M12x1.5	20 Nm (14.8 lbf ft)	–
Screw-in fitting, clutch cover	M12x1.5	20 Nm (14.8 lbf ft)	Loctite® 243™
Axle, timing chain guide rail	M14x1	15 Nm (11.1 lbf ft)	–
Axle, timing chain tensioning rail	M14x1	15 Nm (11.1 lbf ft)	–
Nut, compensating sprocket	M14x1	20 Nm (14.8 lbf ft)	Loctite® 243™
Oil suction pipe	M14x1	15 Nm (11.1 lbf ft)	Loctite® 243™
Oil pressure regulator valve plug	M14x1.5	18 Nm (13.3 lbf ft)	–
Nut, inner clutch hub	M18x1.5	80 Nm (59 lbf ft)	Loctite® 243™
Plug, timing chain tensioner	M24x1.5	25 Nm (18.4 lbf ft)	–
Screw, alternator cover	M24x1.5	8 Nm (5.9 lbf ft)	–

Nut, freewheel hub	M27x1	80 Nm (59 lbf ft)	Loctite® 243™
Nut, primary gear	M27x1	80 Nm (59 lbf ft)	Loctite® 243™
Plug, oil screen	M32x1.5	30 Nm (22.1 lbf ft)	Lubricated with engine oil

20.3 Capacities

20.3.1 Engine oil

Engine oil			
Oil change	1.20 l (1.27 qt.)	Engine oil (SAE 10W/60) (00062010035) (☛ p. 116)	
		Engine oil (SAE 10W/50) (☛ p. 116)	
Engine service	1.50 l (1.59 qt.)	Engine oil (SAE 10W/60) (00062010035) (☛ p. 116)	
		Engine oil (SAE 10W/50) (☛ p. 116)	

20.3.2 Coolant

Coolant	1.2 l (1.3 qt.)	Coolant (☛ p. 116)
		Coolant (mixed ready to use) (☛ p. 116)

20.3.3 Fuel

Fuel tank capacity		
Fuel tank half, front left, approx.	9.0 l (2.38 US gal)	Super unleaded (ROZ 95/RON 95/PON 91) (☛ p. 117)
Fuel tank half, front right, approx.	9.0 l (2.38 US gal)	Super unleaded (ROZ 95/RON 95/PON 91) (☛ p. 117)
Rear fuel tank, approx.	18.0 l (4.76 US gal)	Super unleaded (ROZ 95/RON 95/PON 91) (☛ p. 117)
Total fuel capacity, approx.	36.0 l (9.51 US gal)	Super unleaded (ROZ 95/RON 95/PON 91) (☛ p. 117)

20.4 Chassis

Frame	Lattice frame of chromium-molybdenum steel tubes, powder-coated	
Suspension travel		
Front	300 mm (11.81 in)	
Rear	310 mm (12.2 in)	
Fork offset		
Mark 1 visible	20 mm (0.79 in)	
No mark	22 mm (0.87 in)	
Brake system	Disc brakes, brake calipers on floating bearings	
Brake discs - diameter		
Front	300 mm (11.81 in)	
Rear	240 mm (9.45 in)	
Brake discs - wear limit		
Front	4.5 mm (0.177 in)	
Rear	3.5 mm (0.138 in)	
Tire air pressure on road		
Front	1.5 bar (22 psi)	
Rear	1.5 bar (22 psi)	
Tire air pressure off road		
Front	1.0... 1.5 bar (15... 22 psi)	
Rear	1.0... 1.5 bar (15... 22 psi)	
Secondary drive ratio	15:44 (15:48)	
Rear sprockets available	44, 46, 48, 49, 50, 51	
Chain	5/8 x 1/4"	
Wheelbase	1,535±10 mm (60.43±0.39 in)	

Steering head angle	62.5°
Seat height unloaded	980 mm (38.58 in)
Ground clearance unloaded	320 mm (12.6 in)
Weight without fuel, approx.	145 kg (320 lb.)
Maximum permissible front axle load	190 kg (419 lb.)
Maximum permissible rear axle load	250 kg (551 lb.)
Maximum permissible overall weight	400 kg (882 lb.)
Standard rider weight	80 kg (176 lb.)

20.5 Electrical system

Lithium-ion battery	Battery voltage: 13.2 V Nominal capacity: 4.6 Ah maintenance-free	
Fuse	58011109105	5 A
Fuse	58011109110	10 A
Fuse	58011109115	15 A
Fuse	58011109130	30 A
High beam	HB3 / socket P20d	12 V 60 W
Low beam	HB3 / socket P20d	12 V 60 W
Parking light	W5W / socket W2.1x9.5d	12 V 5 W
Indicator lamps	W1.2W / socket W2x4.6d	12 V 1.2 W
Turn signal	RY10W / socket BAU15s	12 V 10 W
Brake / tail light	LED	
License plate lamp	W5W / socket W2.1x9.5d	12 V 5 W

20.6 Tires

Front tires	Rear tires
90/90 - 21 54S TT Michelin T63	130/80 - 18 66S TT Michelin T63
Additional information is available in the Service section under: http://www.ktm.com	

20.7 Fork

Fork part number	14.18.7K.51
Fork	WP Suspension Up Side Down 4860 MXMA CC
Compression damping	
Standard	10 clicks
Rebound damping	
Standard	20 clicks
Spring length with preload spacer(s)	492 mm (19.37 in)
Spring rate	
Weight of rider: 65... 75 kg (143... 165 lb.)	4.6 N/mm (26.3 lb/in)
Weight of rider (standard): 75... 85 kg (165... 187 lb.)	4.8 N/mm (27.4 lb/in)
Weight of rider (hard): 75... 85 kg (165... 187 lb.)	5.0 N/mm (28.6 lb/in)
Gas pressure	1.8 bar (26 psi)
Fork length	950 mm (37.4 in)

Oil capacity fork leg without cartridge	400 ml (13.52 fl. oz.)	Fork oil (SAE 4) (48601166S1) (☛ p. 117)
---	------------------------	--

20.8 Shock absorber

Shock absorber part number	12.18.7K.51	
Shock absorber	WP Suspension 5018 DACC	
Compression damping, low-speed		
Standard	10 clicks	
Compression damping, high-speed		
Standard	1.5 turns	
Rebound damping		
Standard	18 clicks	
Spring preload		
Standard	17 mm	
Spring rate		
Weight of rider:: 75... 85 kg (165... 187 lb.)	80 N/mm (457 lb/in)	
Spring length	250 mm (9.84 in)	
Gas pressure	10 bar (145 psi)	
Static sag	36 mm (1.42 in)	
Riding sag	100 mm (3.94 in)	
Fitted length	432 mm (17.01 in)	
Shock absorber oil	Shock absorber oil (SAE 2.5) (50180342S1) (☛ p. 117)	

20.9 Chassis tightening torques

Screw, license plate holder, bottom	EJOT	3 Nm (2.2 lbf ft)	–
Screw, license plate lamp	EJOT PT K50x18 T20	1.5 Nm (1.11 lbf ft)	–
Screw, tail light	EJOT PT K60x20	2 Nm (1.5 lbf ft)	–
Spoke nipple, front wheel	M4.5	5... 6 Nm (3.7... 4.4 lbf ft)	–
Remaining nuts, chassis	M5	5 Nm (3.7 lbf ft)	–
Remaining screws, chassis	M5	5 Nm (3.7 lbf ft)	–
Screw, additional tail light	M5	2 Nm (1.5 lbf ft)	–
Screw, air baffle	M5	1 Nm (0.7 lbf ft)	–
Screw, brake line holder on bottom triple clamp	M5	2 Nm (1.5 lbf ft)	–
Screw, foot brake lever foothold	M5	6 Nm (4.4 lbf ft)	Loctite® 243™
Screw, fuel tank closure flange	M5	2.5 Nm (1.84 lbf ft)	–
Screw, fuel tap on frame	M5	5 Nm (3.7 lbf ft)	–
Screw, headlight cover	M5	1 Nm (0.7 lbf ft)	–
Screw, shock absorber adjusting ring	M5	5 Nm (3.7 lbf ft)	–
Screw, trim	M5	2 Nm (1.5 lbf ft)	–
Spoke nipple, rear wheel	M5	5... 6 Nm (3.7... 4.4 lbf ft)	–
Nut, cable on battery	M6	5 Nm (3.7 lbf ft)	–
Nut, cable on starter motor	M6	10 Nm (7.4 lbf ft)	–
Remaining nuts, chassis	M6	10 Nm (7.4 lbf ft)	–
Remaining screws, chassis	M6	10 Nm (7.4 lbf ft)	–
Screw connection, foot brake cylinder	M6	10 Nm (7.4 lbf ft)	Loctite® 243™
Screw connection, spring holder at side stand bracket	M6	10 Nm (7.4 lbf ft)	Loctite® 243™
Screw connection, voltage regulator	M6	8 Nm (5.9 lbf ft)	Loctite® 243™
Screw, air filter box top	M6	2 Nm (1.5 lbf ft)	–
Screw, bottom radiator bracket	M6	5 Nm (3.7 lbf ft)	–

Screw, brake fluid reservoir of rear brake	M6	5 Nm (3.7 lbf ft)	–
Screw, cable on starter relay	M6	5 Nm (3.7 lbf ft)	–
Screw, chain sliding guard	M6	6 Nm (4.4 lbf ft)	Loctite® 243™
Screw, engine guard bracket on engine bearer	M6	15 Nm (11.1 lbf ft)	–
Screw, front brake disc	M6	14 Nm (10.3 lbf ft)	Loctite® 243™
Screw, rear brake disc	M6	14 Nm (10.3 lbf ft)	Loctite® 243™
Screw, seat holder	M6	15 Nm (11.1 lbf ft)	–
Screw, seat lock	M6	5 Nm (3.7 lbf ft)	–
Screw, steering damper	M6	15 Nm (11.1 lbf ft)	–
Screw, steering damper bracket	M6	15 Nm (11.1 lbf ft)	–
Silentblock, air filter box	M6	2 Nm (1.5 lbf ft)	–
Nut, rear sprocket screw	M8	35 Nm (25.8 lbf ft)	Loctite® 243™
Nut, rim lock	M8	10 Nm (7.4 lbf ft)	–
Remaining nuts, chassis	M8	30 Nm (22.1 lbf ft)	–
Remaining screws, chassis	M8	25 Nm (18.4 lbf ft)	–
Screw connection, rear fuel tank, bottom	M8	25 Nm (18.4 lbf ft)	Loctite® 243™
Screw, bottom triple clamp	M8	12 Nm (8.9 lbf ft)	–
Screw, chain sliding piece	M8	15 Nm (11.1 lbf ft)	–
Screw, connection lever on frame	M8	30 Nm (22.1 lbf ft)	Loctite® 243™
Screw, engine bearer on frame	M8	35 Nm (25.8 lbf ft)	Loctite® 243™
Screw, foot brake lever	M8	25 Nm (18.4 lbf ft)	Loctite® 243™
Screw, fork stub	M8	15 Nm (11.1 lbf ft)	–
Screw, front brake caliper	M8	30 Nm (22.1 lbf ft)	Loctite® 243™
Screw, front fuel tank	M8	8 Nm (5.9 lbf ft)	–
Screw, fuel tank bracket	M8	15 Nm (11.1 lbf ft)	–
Screw, handlebar clamp	M8	16 Nm (11.8 lbf ft)	–
Screw, license plate holder, top	M8	20 Nm (14.8 lbf ft)	–
Screw, motor guard	M8	25 Nm (18.4 lbf ft)	–
Screw, rear fuel tank, top	M8	25 Nm (18.4 lbf ft)	Loctite® 243™
Screw, side stand bracket	M8	25 Nm (18.4 lbf ft)	Loctite® 243™
Screw, steering stem, bottom	M8	25 Nm (18.4 lbf ft)	Loctite® 243™
Screw, top steering stem	M8	20 Nm (14.8 lbf ft)	–
Screw, top triple clamp	M8	17 Nm (12.5 lbf ft)	–
Remaining nuts, chassis	M10	50 Nm (36.9 lbf ft)	–
Remaining screws, chassis	M10	45 Nm (33.2 lbf ft)	–
Screw connection, engine mounting bracket	M10	45 Nm (33.2 lbf ft)	Loctite® 243™
Screw connection, shock absorber, bottom	M10	45 Nm (33.2 lbf ft)	Loctite® 243™
Screw connection, shock absorber, top	M10	45 Nm (33.2 lbf ft)	Loctite® 243™
Screw, handlebar support	M10	40 Nm (29.5 lbf ft)	Loctite® 243™
Screw, side stand	M10	35 Nm (25.8 lbf ft)	Loctite® 243™
Banjo bolt	M10x1	12 Nm (8.9 lbf ft)	–
Nut, turn signal	M10x1.25	8 Nm (5.9 lbf ft)	–
Nut, angle lever on swingarm	M14x1.5	100 Nm (73.8 lbf ft)	–
Nut, linkage lever to angle lever	M14x1.5	100 Nm (73.8 lbf ft)	–
Nut, swingarm pivot	M14x1.5	100 Nm (73.8 lbf ft)	–
Nut, upper steering head	M20x1	12 Nm (8.9 lbf ft)	–
Screw, top steering head	M20x1	12 Nm (8.9 lbf ft)	–
Screw, front wheel spindle	M24x1.5	40 Nm (29.5 lbf ft)	–

Nut, rear wheel spindle	M25x1.5	90 Nm (66.4 lbf ft)	–
-------------------------	---------	---------------------	---

20.10 Carburetor with carburetor configuration (carburetor sheets)

Carburetor type	KEIHIN FCR-MX 41
Carburetor identification number	4100D
Needle position	3 th position from top
Idle mixture adjusting screw	
Open	1.5 turns
Main jet	185
Jet needle	OBDVT (OBDTQ)
Idling jet	42
Idle air jet	100
Cold start jet	85

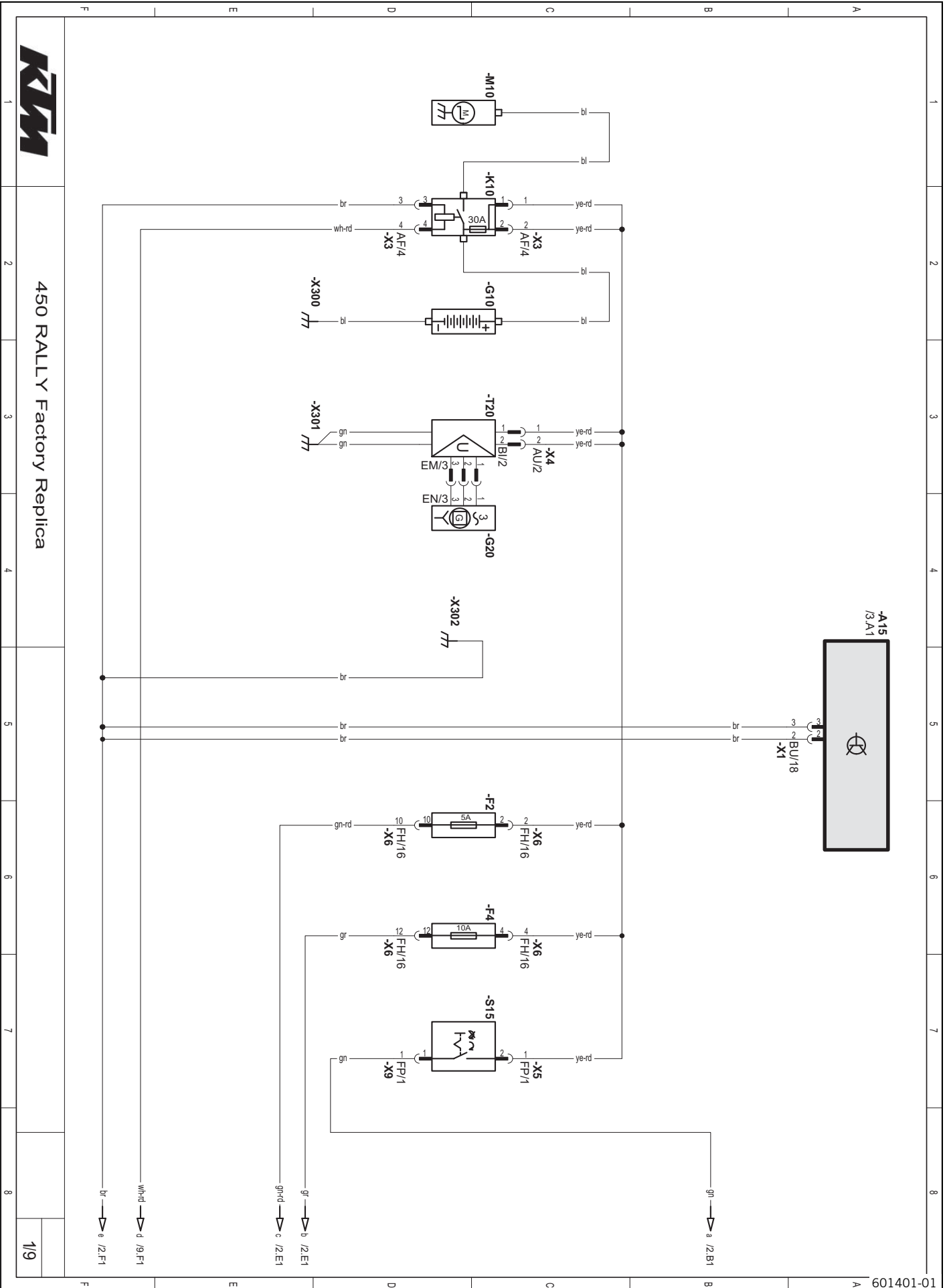

450 RALLY Factory Replica

Components:

A15	CDI controller
F2	Fuse
F4	Fuse
G10	Battery
G20	Alternator
K10	Starter relay with main fuse
M10	Starter motor
T20	Voltage regulator
S15	Ignition switch

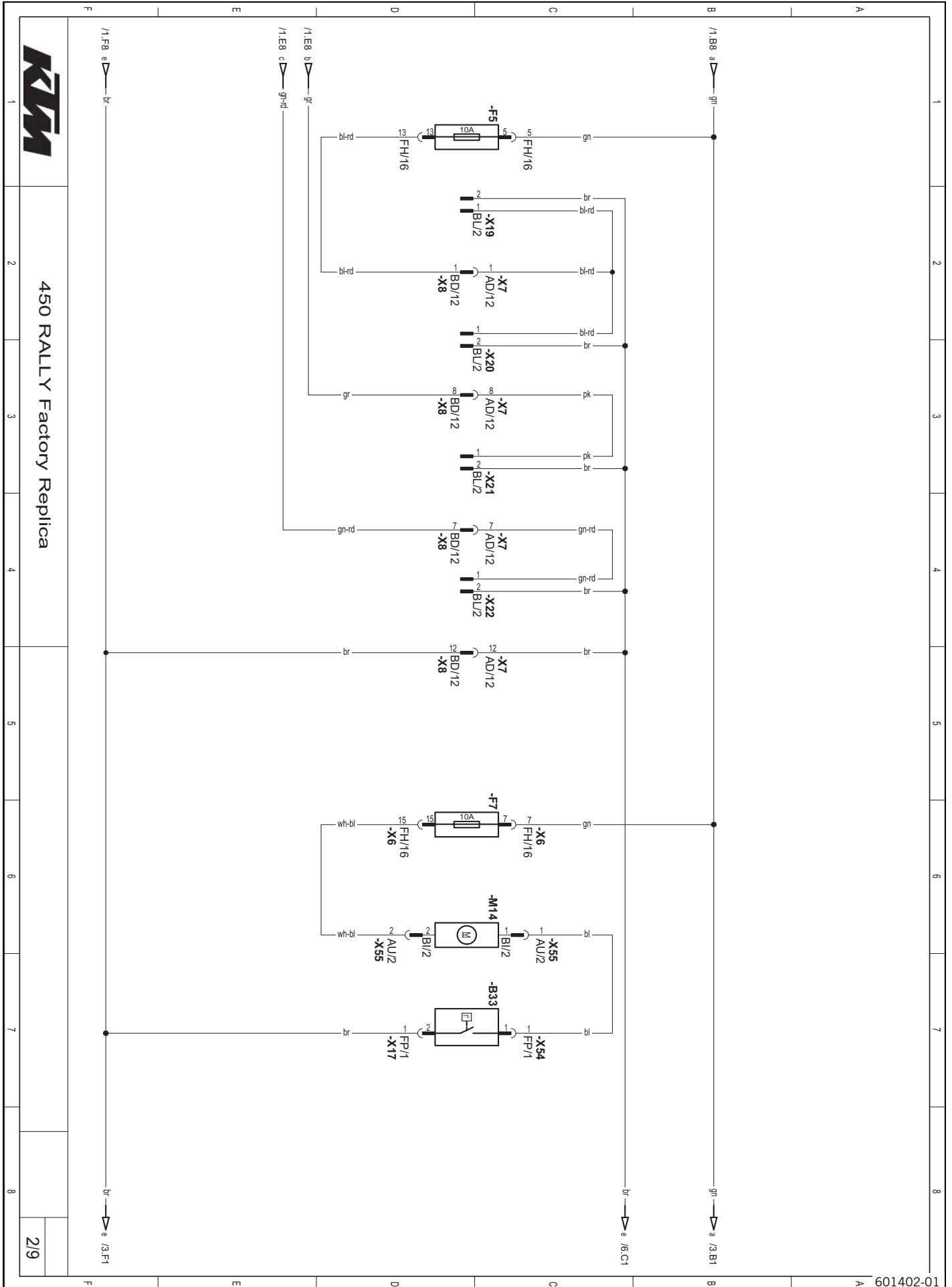

450 RALLY Factory Replica

Components:

B33	Radiator fan temperature switch
-----	---------------------------------

F5	Fuse
----	------

F7	Fuse
----	------

M14	Radiator fan
-----	--------------

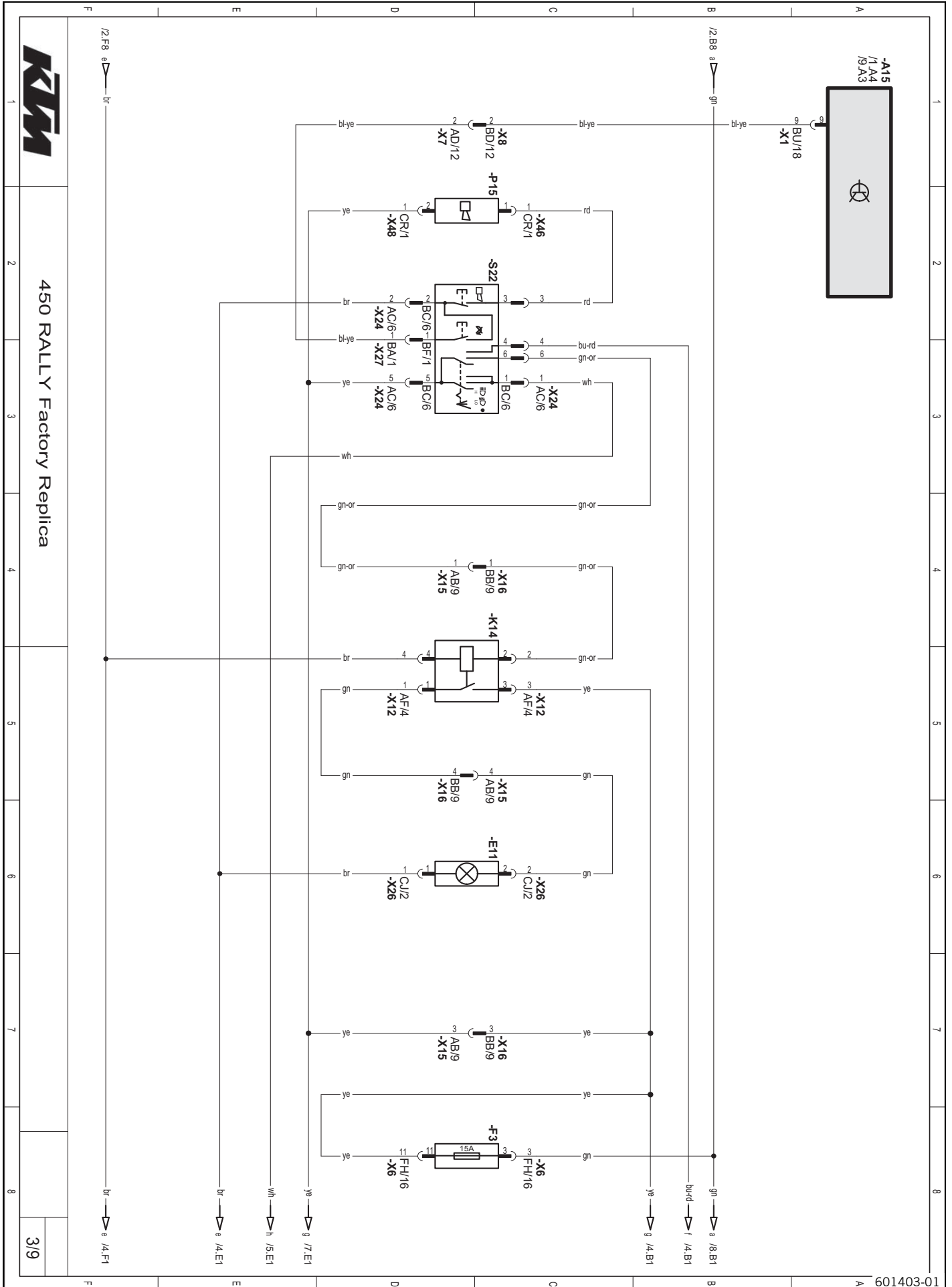

450 RALLY Factory Replica

Components:

A15	CDI controller
E11	Low beam
F3	Fuse
K14	Low beam relay
P15	Horn
S22	Light switch, horn button, kill switch

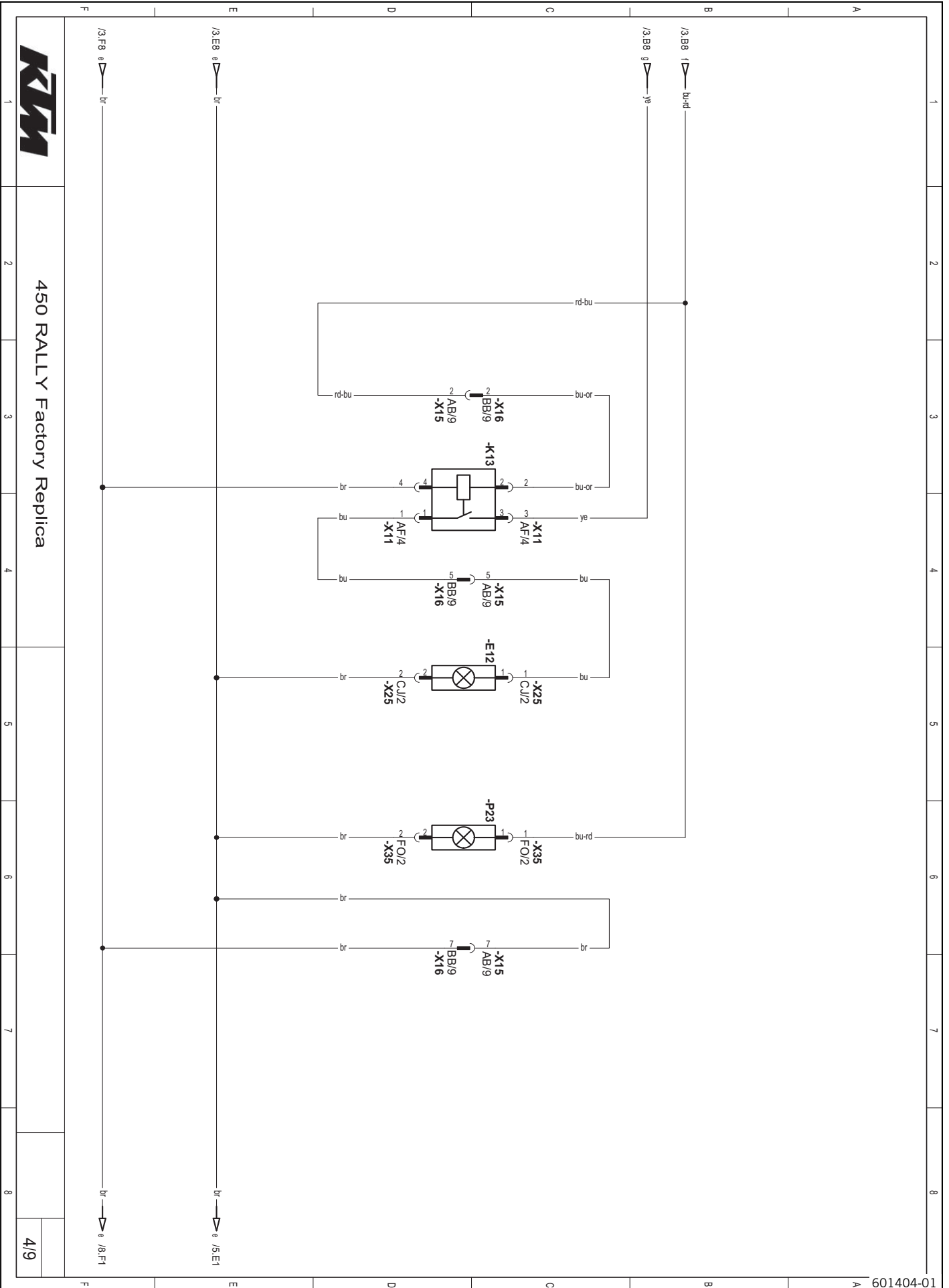

Components:

E12	High beam
K13	High beam relay
P23	High beam indicator light

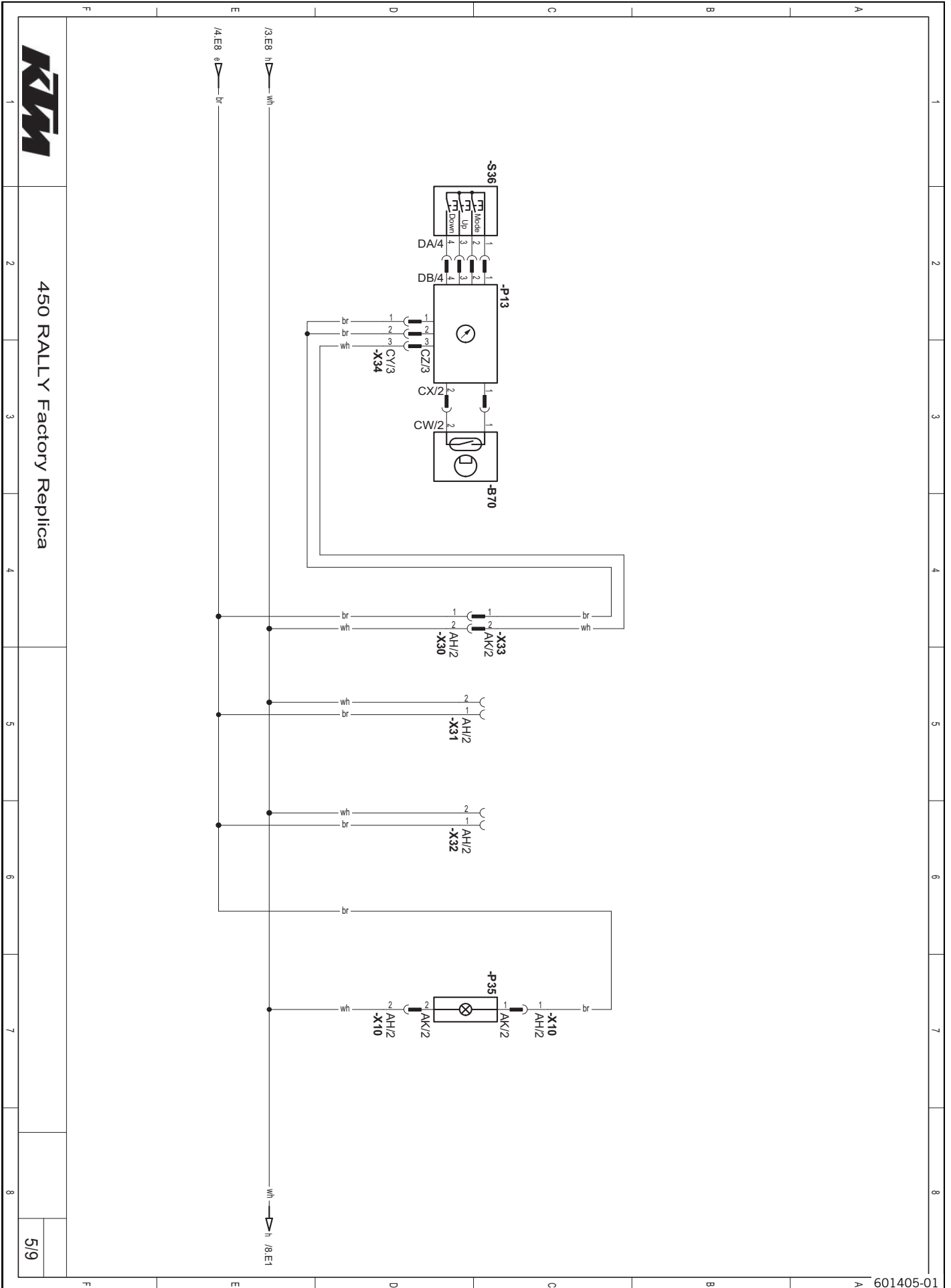

450 RALLY Factory Replica

Components:

B70	Wheel speed sensor, front
P13	Speedometer
P35	Parking light
S36	Tripmaster switch

Components:

K20	Turn signal relay
P21	Turn signal indicator light
P22	Idling speed indicator lamp
P41	Front left turn signal
P42	Front right turn signal
P45	Rear left turn signal
P46	Rear right turn signal
S25	Turn signal switch

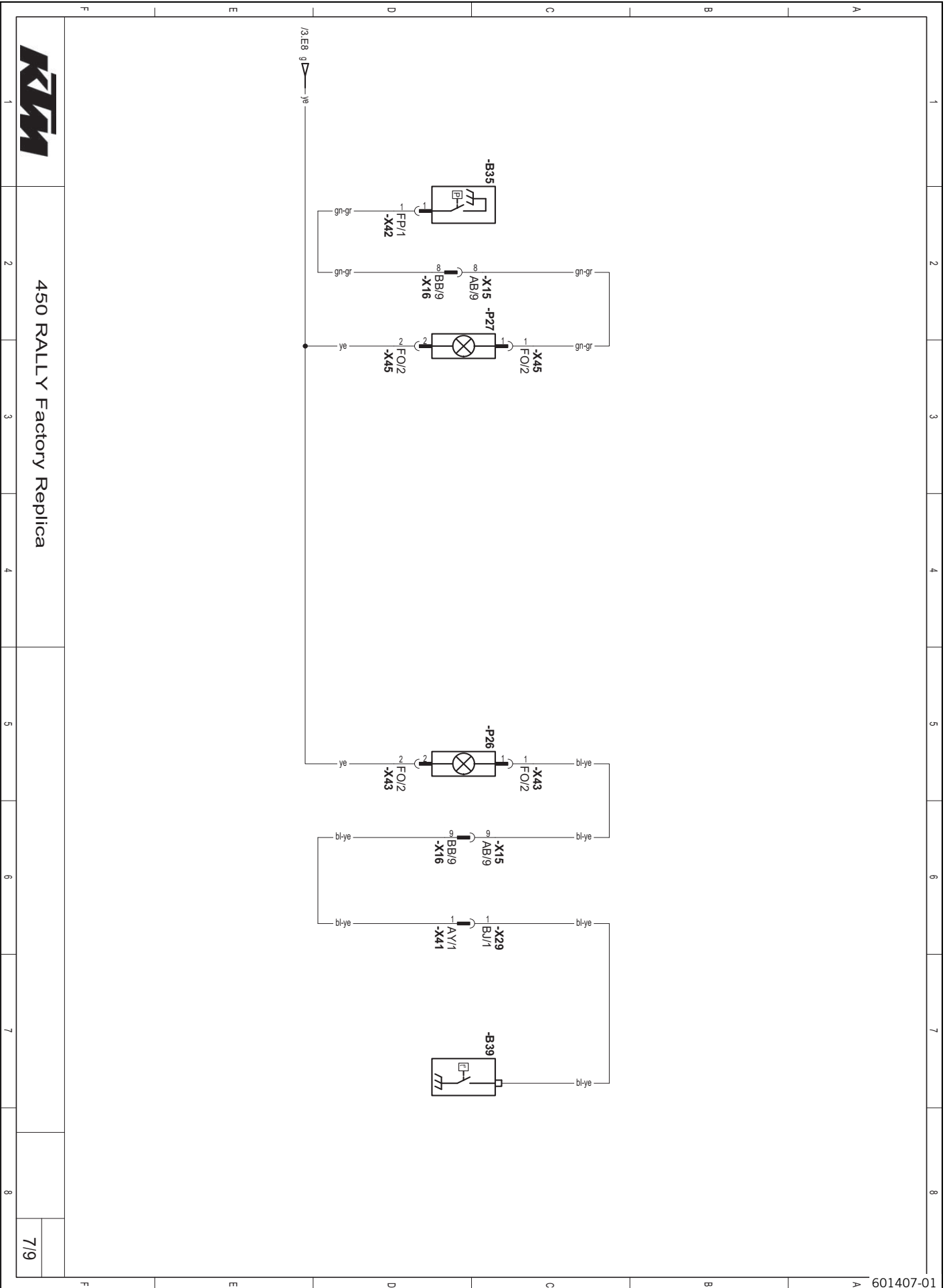

Components:

B35	Oil pressure sensor
B39	Temperature switch indicator lamp
P26	Temperature warning lamp
P27	Oil pressure warning lamp

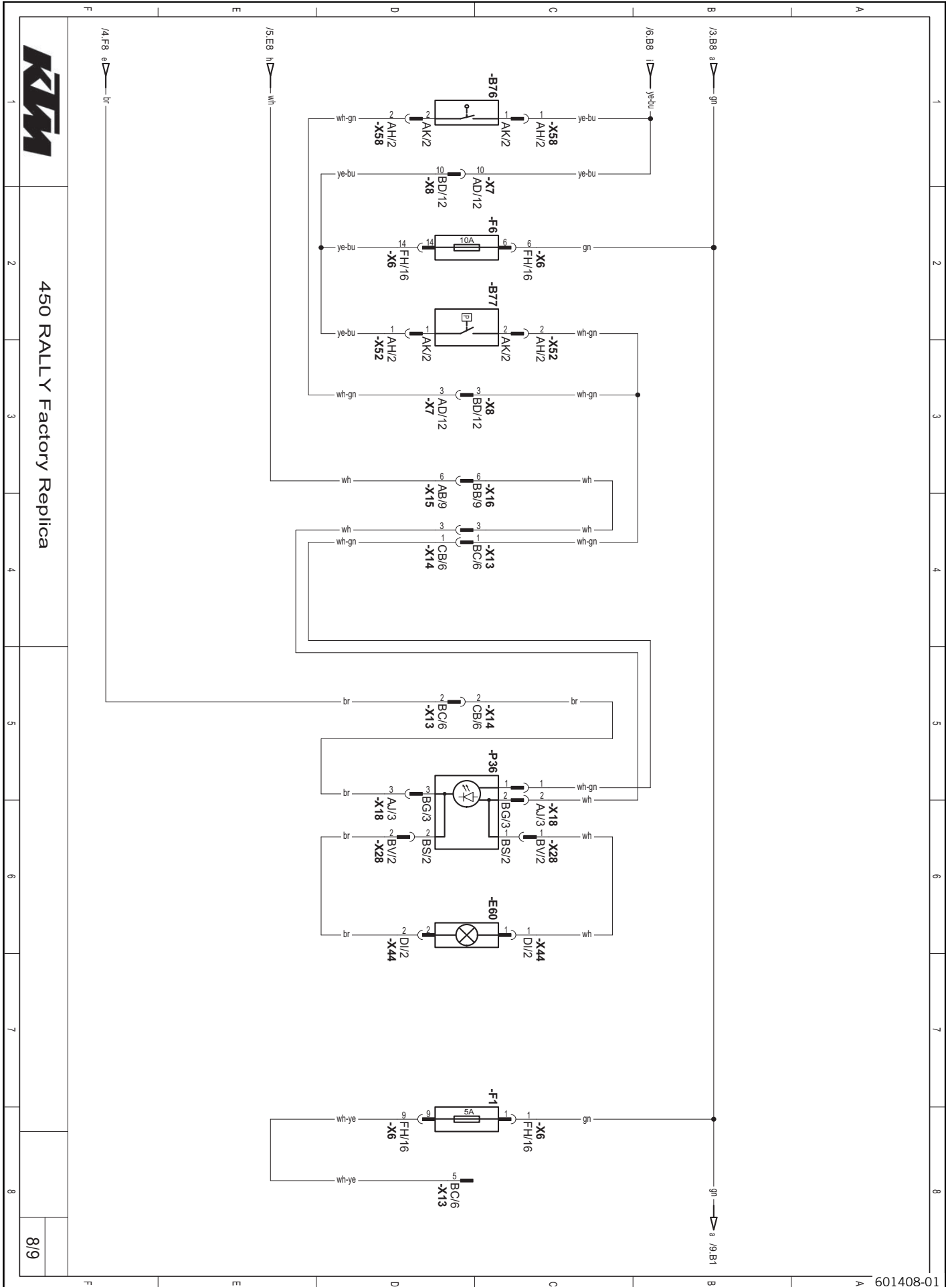

450 RALLY Factory Replica

Components:

B76	Front brake light switch
B77	Rear brake light switch
E60	License plate lamp
F1	Fuse
F6	Fuse
P36	Brake/tail light

Components:

A15	CDI controller
B10	Throttle position sensor circuit A
B37	Pulse generator
F8	Fuse
R51	Ignition coil (cylinder 1)
S23	Emergency OFF switch, electric starter button
X280	Connector, ignition curve
X281	Connector, ignition curve

Cable colors:

bl	Black
br	Brown
bu	Blue
gn	Green
gr	Gray
lbu	Light blue
or	Orange
pk	Pink
pu	Violet
rd	Red
wh	White
ye	Yellow

Brake fluid DOT 4 / DOT 5.1

According to

- DOT

Guideline

- Use only brake fluid that complies with the specified standard (see specifications on the container) and that possesses the corresponding properties. KTM recommends **Castrol** and **Motorex®** products.

Supplier

Castrol

- **RESPONSE BRAKE FLUID SUPER DOT 4**

Motorex®

- **Brake Fluid DOT 5.1**

Coolant

Guideline

- Use only suitable coolant (also in countries with high temperatures). Use of low-quality antifreeze can lead to corrosion and foaming. KTM recommends **Motorex®** products.

Mixture ratio

Antifreeze protection: -25... -45 °C (-13... -49 °F)	50 % corrosion inhibitor/antifreeze 50 % distilled water
--	---

Coolant (mixed ready to use)

Antifreeze	-40 °C (-40 °F)
------------	-----------------

Supplier

Motorex®

- **COOLANT G48**

Engine oil (SAE 10W/60) (00062010035)

According to

- JASO T903 MA (☛ p. 120)
- SAE (☛ p. 120) (SAE 10W/60)
- KTM LC4 2007+

Guideline

- Use only engine oils that comply with the specified standards (see specifications on the container) and that possess the corresponding properties. KTM recommends **Motorex®** products.

Synthetic engine oil

Supplier

Motorex®

- **Cross Power 4T**

Engine oil (SAE 10W/50)

According to

- JASO T903 MA (☛ p. 120)
- SAE (☛ p. 120) (SAE 10W/50)

Guideline

- Use only engine oils that comply with the specified standards (see specifications on the container) and that possess the corresponding properties. KTM recommends **Motorex®** products.

Synthetic engine oil

Supplier

Motorex®

- **Cross Power 4T**

Fork oil (SAE 4) (48601166S1)

According to

- SAE (☛ p. 120) (SAE 4)

Guideline

- Use only oils that comply with the specified standards (see specifications on the container) and that possess the corresponding properties.

Hydraulic fluid (15)

According to

- ISO VG (15)

Guideline

- Use only hydraulic oil that complies with the specified standard (see specifications on the container) and that possesses the corresponding properties. KTM recommends **Motorex®** products.

Supplier

Motorex®

- Hydraulic Fluid 75

Shock absorber oil (SAE 2.5) (50180342S1)

According to

- SAE (☛ p. 120) (SAE 2.5)

Guideline

- Use only oils that comply with the specified standards (see specifications on the container) and that possess the corresponding properties.

Super unleaded (ROZ 95/RON 95/PON 91)

According to

- DIN EN 228 (ROZ 95/RON 95/PON 91)

Guideline

- Only use unleaded super fuel that matches or is equivalent to the specified fuel grade.
- Fuel with an ethanol content of up to 10 % (E10 fuel) is safe to use.



Info

Do **not** use fuel containing methanol (e. g. M15, M85, M100) or more than 10 % ethanol (e. g. E15, E25, E85, E100).

Chain cleaner

Guideline

- KTM recommends **Motorex®** products.

Supplier

Motorex®

- **Chain Clean**

Cleaning and preserving materials for metal, rubber and plastic

Guideline

- KTM recommends **Motorex®** products.

Supplier

Motorex®

- **Protect & Shine**

Fuel additive

Guideline

- KTM recommends **Motorex®** products.

Supplier

Motorex®

- **Fuel Stabilizer**

High viscosity grease

Guideline

- KTM recommends **SKF®** products.

Supplier

SKF®

- **LGHB 2**

Long-life grease

Guideline

- KTM recommends **Motorex®** products.

Supplier

Motorex®

- **Bike Grease 2000**

Motorcycle cleaner

Guideline

- KTM recommends **Motorex®** products.

Supplier

Motorex®

- **Moto Clean 900**

Off-road chain spray

Guideline

- KTM recommends **Motorex®** products.

Supplier

Motorex®

- **Chainlube Offroad**

Paint cleaner and polish for high-gloss and matte finishes, bare metal and plastic surfaces

Guideline

- KTM recommends **Motorex®** products.

Supplier

Motorex®

- **Clean & Polish**

Rubber grip adhesive (00062030051)

Supplier

KTM-Sportmotorcycle AG

- **GRIP GLUE**

Universal oil spray

Guideline

- KTM recommends **Motorex®** products.

Supplier

Motorex®

- **Joker 440 Synthetic**

JASO T903 MA

Different technical development directions required a new specification for 4-stroke motorcycles – the JASO T903 MA Standard. Earlier, engine oils from the automobile industry were used for 4-stroke motorcycles because there was no separate motorcycle specification. Whereas long service intervals are demanded for automobile engines, high performance at high engine speeds are in the foreground for motorcycle engines. In most motorcycles, the gearbox and the clutch are lubricated with the same oil as the engine. The JASO MA Standard meets these special requirements.

SAE

The SAE viscosity classes were defined by the Society of Automotive Engineers and are used for classifying oils according to their viscosity. The viscosity describes only one property of oil and says nothing about quality.

A	
Accessories	7
Air filter	
installing	49
removing	48
Antifreeze	
checking	77
Auxiliary substances	7
B	
Basic chassis setting	
checking with rider's weight	32
Battery	
installing	73
recharging	73
removing	73
Brake discs	
checking	59
Brake fluid	
front brake, adding	60
rear brake, adding	64
Brake fluid level	
front brake, checking	60
rear brake, checking	64
Brake linings	
front brake, changing	61
front brake, checking	61
rear brake, changing	65
rear brake, checking	65
C	
Capacities	
coolant	78, 93
engine oil	93
fuel	29, 93
Carburetor	
float chamber, emptying	82
idle	80
idle, adjusting	81
Chain	
checking	53
cleaning	52
Chain guide	
checking	53
Chain tension	
adjusting	53
checking	52
Chassis number	10
Choke	21
Cleaning	88-89
Clutch	
fluid level, checking	56
fluid, changing	56
Clutch lever	12
basic position, adjusting	56
Compression damping	
fork, adjusting	36

Compression damping, high-speed	
shock absorber, adjusting	32
Compression damping, low-speed	
shock absorber, adjusting	33
Coolant	
draining	78
refilling	78
Coolant level	
checking	77
Cooling system	77
Customer service	7
E	
Electric starter button	13
Engine	
running in	25
Engine number	10
Engine oil	
adding	86
changing	84
Engine oil level	
checking	84
Engine sprocket	
checking	53
Environment	6
F	
Figures	7
Foot brake lever	22
free travel, adjusting	63
free travel, checking	63
Fork legs	
basic setting, checking	35
bleeding	40
dust boots, cleaning	41
installing	43
removing	42
Fork offset	36
setting	37
Frame	
checking	55
Front fender	
dismounting at front	41
installing at front	41
Front wheel	
installing	67
removing	67
Fuel tank	20
Fuel tank, front	
installing	51
removing	50
Fuel tap	20
Fuse	
main fuse, changing	74
of individual power consumer, changing	75

H	
Hand brake lever	12
free travel, adjusting	59
free travel, checking	59
Handlebar position	38
adjusting	38
Headlight	
headlight range, adjusting	76
Headlight setting	
checking	75
Horn button	13
I	
Ignition switch	13
Indicator lamp overview	13
Intended use	5
K	
Key number	10
Kill switch	12
L	
Light switch	12
Lower triple clamp	
installing	44
removing	43
M	
Main fuse	
changing	74
Main silencer	
glass fiber yarn filling, changing	50
installing	50
removing	49
Motorcycle	
cleaning	88
raising with lift stand	40
removing from lift stand	40
O	
Oil filter	
changing	84
Oil screen	
cleaning	84
Operating substances	7
Owner's Manual	6
P	
Play in throttle cable	
adjusting	80
checking	80
Preparing for use	
advice on first use	24
after storage	90
checks and maintenance when preparing for use	26
Protective clothing	6
R	
Rear hub rubber dampers	
checking	70

Rear sprocket	
checking	53
Rear wheel	
installing	69
removing	68
Rebound damping	
fork, adjusting	36
shock absorber, adjusting	33
Refueling	
fuel	29
Riding sag	
adjusting	35
Rubber grip	
checking	55
securing	56
S	
Safe operation	6
Seat	
mounting	48
removing	48
Service	7
Service schedule	30-31
Shift lever	21
basic position, adjusting	83
basic position, checking	83
Shock absorber	
compression damping, general	32
riding sag, checking	34
spring preload, adjusting	34
static sag, checking	34
Side stand	22
Spare parts	7
Speedometer	
adjusting	15
clock, setting	15
kilometers or miles, setting	14
overview	14
Spoke tension	
checking	71
Starting	26
Steering	
locking	22
unlocking	23
Steering head bearing	
greasing	47
Steering head bearing play	
adjusting	46
checking	46
Steering lock	22
Storage	90
Swingarm	
checking	55
T	
Technical data	
capacities	93

chassis	93
chassis tightening torques	95
electrical system	94
engine	91
engine tightening torques	91
fork	94
shock absorber	95
tires	94
Throttle grip	12
Tire air pressure	
checking	71
Tire condition	
checking	70
Transport	28
Trim	
mounting	57
removing	57
Turn signal switch	13
Type label	10
U	
Use definition	5
V	
View of vehicle	
front left	8
rear right	9
W	
Warranty	7
Winter operation	
checks and maintenance steps	89
Wiring diagram	
page 1 of 9	98
page 2 of 9	100
page 3 of 9	102
page 4 of 9	104
page 5 of 9	106
page 6 of 9	108
page 7 of 9	110
page 8 of 9	112
page 9 of 9	114
Work rules	6



3211865en

06/2012

