

1290 Super Duke R EU
1290 Super Duke R AUS
1290 Super Duke R FR

Art. no. 3213109en



DEAR KTM CUSTOMER

Congratulations on your decision to purchase a KTM motorcycle. You are now the owner of a state-of-the-art sports motorcycle that will give you enormous pleasure if you service and maintain it accordingly.

We wish you a lot of enjoyment in riding this vehicle.

Enter the serial numbers of your vehicle below.

Chassis number (☛ p. 20)	Dealer's stamp
Engine number (☛ p. 22)	
Key number (☛ p. 21)	

The Owner's Manual contained the latest information for this model series at the time of going to print. Minor differences due to developments in design cannot be ruled out completely.

All specifications are non-binding. KTM Motorrad AG specifically reserves the right to modify or delete technical specifications, prices, colors, forms, materials, services, designs, equipment, etc., without prior notice and without specifying reasons, to adapt these to local conditions, as well as to stop production of a particular model without prior notice. KTM accepts no liability for delivery options, deviations from illustrations and descriptions, misprints, and other errors. The models portrayed partly contain special equipment that does not belong to the regular scope of supply.

© 2014 KTM Motorrad AG, Mattighofen Austria

All rights reserved

Reproduction, even in part, as well as copying of all kinds, is permitted only with the express written permission of the copyright owner.

DEAR KTM CUSTOMER



ISO 9001(12 100 6061)

According to the international quality management standard ISO 9001, KTM uses quality assurance processes that lead to the maximum possible quality of the products.

Issued by: TÜV Management Service

REG.NO. 12 100 6061

KTM Motorrad AG

5230 Mattighofen, Austria

TABLE OF CONTENTS

1	MEANS OF REPRESENTATION	7	5.6	Shock absorber part number	23
1.1	Symbols used	7	5.7	Steering damper item number	23
1.2	Formats used.....	7	6	CONTROLS.....	24
2	SAFETY ADVICE.....	8	6.1	Clutch lever.....	24
2.1	Use definition - intended use	8	6.2	Hand brake lever.....	24
2.2	Safety advice.....	8	6.3	Throttle grip	25
2.3	Degrees of risk and symbols	9	6.4	Switches on the left side of the handlebar	25
2.4	Tampering warning.....	9	6.4.1	Combination switch.....	25
2.5	Safe operation	10	6.4.2	Light switch	26
2.6	Protective clothing	11	6.4.3	Hazard warning flasher switch.....	26
2.7	Work rules	11	6.4.4	Menu switch.....	27
2.8	Environment.....	11	6.4.5	Turn signal switch.....	27
2.9	Owner's Manual	12	6.4.6	Horn button	28
3	IMPORTANT NOTES.....	13	6.5	Switches on the right side of the handlebar	28
3.1	Guarantee, warranty	13	6.5.1	Emergency OFF switch	28
3.2	Operating and auxiliary substances	13	6.5.2	Electric starter button	29
3.3	Spare parts, accessories	13	6.6	Ignition/steering lock	29
3.4	Service	13	6.7	Immobilizer	30
3.5	Figures	14	6.8	Opening the filler cap.....	30
3.6	Customer service.....	14	6.9	Closing the filler cap	32
4	VIEW OF VEHICLE	16	6.10	Seat lock.....	33
4.1	View of vehicle, front left (example)	16	6.11	Baggage lugs	34
4.2	View of vehicle, rear right (example)	18	6.12	Tool set.....	34
5	SERIAL NUMBERS	20	6.13	Supporting strap	35
5.1	Chassis number	20	6.14	Helmet lock.....	35
5.2	Type label	20	6.15	Passenger footrests	36
5.3	Key number.....	21	6.16	Shift lever	36
5.4	Engine number	22	6.17	Foot brake lever	37
5.5	Fork part number	22	6.18	Side stand.....	38

TABLE OF CONTENTS



7	COMBINATION INSTRUMENT	39	7.9.20	"DRL"	55
7.1	Overview	39	8	ERGONOMICS	56
7.2	Activation and test	39	8.1	Handlebar position	56
7.3	Matrix display	40	8.2	Adjusting the handlebar position 	56
7.4	Segment display	40	8.3	Setting the basic setting of the clutch lever	57
7.5	Indicator lamps	41	8.4	Adjusting the basic position of the hand brake lever	58
7.6	Message on the matrix display	42	8.5	Adjusting the basic position of the foot brake lever 	58
7.7	Shift warning light	43	8.6	Setting the step plate of the foot brake lever	59
7.8	Service display	44	8.7	Checking the basic position of the shift lever	60
7.9	Matrix display menu	44	8.8	Adjusting the basic position of the shift lever 	60
7.9.1	"Favorites"	44	8.9	Setting the shift lever stub	61
7.9.2	"Trip 1"	45	9	PREPARING FOR USE	62
7.9.3	"Trip 2"	45	9.1	Advice on first use	62
7.9.4	"General Info"	46	9.2	Running in the engine	63
7.9.5	"Set Favorites"	46	9.3	Loading the vehicle	64
7.9.6	"Settings"	47	10	RIDING INSTRUCTIONS	66
7.9.7	"Warning"	47	10.1	Checks and maintenance measures when preparing for use	66
7.9.8	"Heat Grip" (optional)	48	10.2	Starting	67
7.9.9	"MTC/ABS"	48	10.3	Starting off	68
7.9.10	"Drive Mod"	49	10.4	Shifting, riding	68
7.9.11	Menu overview	50	10.5	Applying the brakes	72
7.9.12	"Language"	51	10.6	Stopping, parking	74
7.9.13	"Distance"	52	10.7	Transport	75
7.9.14	"Temp"	52	10.8	Refueling	76
7.9.15	"Pressure"	53	11	SERVICE SCHEDULE	78
7.9.16	"Fuel Cons"	53	11.1	Additional information	78
7.9.17	"Clock/Date"	54	11.2	Required work	78
7.9.18	"Shift Light"	54			
7.9.19	"Heat Grip"	55			

TABLE OF CONTENTS

11.3	Recommended work	80	13.15	Adjusting the chain tension.....	100
12	SUSPENSION SETTING.....	81	13.16	Checking the chain, rear sprocket, engine sprocket, and chain guide.....	101
12.1	Fork/shock absorber	81	13.17	Checking/correcting the fluid level of the hydraulic clutch.....	104
12.2	Adjusting the compression damping of the fork.....	81	14	BRAKE SYSTEM	106
12.3	Adjusting the rebound damping of the fork.....	82	14.1	ABS/antilock brake system.....	106
12.4	Compression damping of the shock absorber.....	83	14.2	Checking the brake discs	108
12.5	Adjusting the low-speed compression damping of the shock absorber	84	14.3	Checking the brake fluid level of the front brake.....	109
12.6	Adjusting the high-speed compression damping of the shock absorber	85	14.4	Adding front brake fluid 🛠.....	109
12.7	Adjusting the rebound damping of the shock absorber.....	86	14.5	Checking the front brake linings	111
12.8	Adjusting the spring preload of the shock absorber 🛠.....	86	14.6	Checking the rear brake fluid level.....	112
13	SERVICE WORK ON THE CHASSIS.....	89	14.7	Adding rear brake fluid 🛠.....	113
13.1	Lifting the motorcycle with the rear lifting gear	89	14.8	Checking the brake linings of the rear brake	115
13.2	Removing the rear of motorcycle from the lifting gear.....	89	15	WHEELS, TIRES	116
13.3	Lifting the motorcycle with the front lifting gear....	90	15.1	Removing the front wheel 🛠.....	116
13.4	Taking the motorcycle from the front lifting gear ...	91	15.2	Installing the front wheel 🛠.....	117
13.5	Removing the passenger seat	91	15.3	Removing the rear wheel 🛠.....	120
13.6	Mounting the passenger seat.....	92	15.4	Installing the rear wheel 🛠.....	121
13.7	Removing the front rider's seat	92	15.5	Checking the tire condition	123
13.8	Mounting the front rider's seat.....	93	15.6	Checking the tire air pressure.....	125
13.9	Mounting the helmet lock on the vehicle	93	16	ELECTRICAL SYSTEM	126
13.10	Disassembling the main silencer 🛠.....	94	16.1	Daytime running light.....	126
13.11	Installing the main silencer 🛠.....	96	16.2	Removing the battery 🛠.....	126
13.12	Checking the chain for dirt.....	97	16.3	Installing the battery 🛠.....	128
13.13	Cleaning the chain	97	16.4	Recharging the battery 🛠.....	131
13.14	Checking the chain tension	99	16.5	Changing the main fuse.....	135
			16.6	Changing the fuses in the fuse box	138
			16.7	Changing the headlight bulb	141

TABLE OF CONTENTS

16.8	Checking the headlight setting	143	23.3.3	Fuel	175
16.9	Adjusting the headlight range.....	144	23.4	Chassis	175
16.10	Activating/deactivating the ignition key	145	23.5	Electrical system.....	176
17	COOLING SYSTEM	150	23.6	Tires	177
17.1	Checking the coolant level in the compensating tank.....	150	23.7	Fork.....	177
17.2	Correcting the coolant level in the compensating tank.....	151	23.8	Shock absorber	178
18	ENGINE TUNING	153	23.9	Chassis tightening torques	180
18.1	"Drive Mod"	153	24	SUBSTANCES	185
18.2	MTC/motorcycle traction control	153	25	AUXILIARY SUBSTANCES	188
19	SERVICE WORK ON THE ENGINE	154	26	STANDARDS	190
19.1	Checking the engine oil level.....	154	INDEX	191	
19.2	Changing the engine oil and filter, cleaning the oil screens 🐼.....	155			
19.3	Adding engine oil	159			
20	CLEANING, CARE	162			
20.1	Cleaning motorcycle	162			
20.2	Checks and maintenance steps for winter operation.....	164			
21	STORAGE.....	166			
21.1	Storage	166			
21.2	Preparing for use after storage.....	167			
22	TROUBLESHOOTING	168			
23	TECHNICAL DATA.....	170			
23.1	engine	170			
23.2	Engine tightening torques	171			
23.3	Capacities	174			
23.3.1	Engine oil	174			
23.3.2	Coolant	175			

1 MEANS OF REPRESENTATION

1.1 Symbols used

The meaning of specific symbols is described below.



Indicates an expected reaction (e.g. of a work step or a function).



Indicates an unexpected reaction (e.g. of a work step or a function).



All work marked with this symbol requires specialist knowledge and technical understanding. In the interest of your own safety, have these jobs performed by an authorized KTM workshop. There, your motorcycle will be optimally cared for by specially trained experts using the specialist tools required.



Indicates a page reference (more information is provided on the specified page).

1.2 Formats used

The typographical formats used in this document are explained below.

Specific name Identifies a proprietary name.

Name® Identifies a protected name.

Brand™ Identifies a brand available on the open market.

2.1 Use definition - intended use

KTM sport motorcycles are designed and constructed to meet the normal demands of regular road operation and also for use on race courses, but not for offroad use.



Info

The motorcycle is only authorized for operation on public roads in the homologated version.

2.2 Safety advice

A number of safety instructions need to be followed to operate the vehicle safely. Therefore, read this manual carefully. The safety instructions are highlighted in the text and are referred to at the relevant passages.



Info

The vehicle has various information and warning labels at prominent locations. Do not remove information/warning labels. If they are missing, you or others may not recognize dangers and may therefore be injured.

2.3 Degrees of risk and symbols

**Danger**

Indicates a danger that will immediately and invariably lead to fatal or serious permanent injury if the appropriate measures are not taken.

**Warning**

Indicates a danger that is likely to lead to fatal or serious injury if the appropriate measures are not taken.

**Caution**

Indicates a danger that may lead to minor injuries if the appropriate measures are not taken.

Note

Indicates a danger that will lead to considerable machine and material damage if the appropriate measures are not taken.

**Warning**

Indicates a danger that will lead to environmental damage if the appropriate measures are not taken.

2.4 Tampering warning

Tampering with the noise control system is prohibited. Federal law prohibits the following acts or the causing thereof:

- 1 The removal or rendering inoperative by any person other than for purposes of maintenance, repair, or replacement, of any device or element of design incorporated into any new vehicle for the purpose of noise control prior to its sale or delivery to the ultimate purchaser or while it is in use, or
- 2 the use of the vehicle after such device or element of design has been removed or rendered inoperative by any person.

Among those acts presumed to constitute tampering are the acts listed below:

- 1 Removal or puncturing of the main silencer, baffles, header pipes or any other components which conduct exhaust gases.
- 2 Removal or puncturing of parts of the intake system.
- 3 Lack of proper maintenance.
- 4 Replacing moving part of the vehicle, or parts of the exhaust or intake system, with parts other than those specified by the manufacturer.

2.5 Safe operation



Danger

Danger of accidents Danger arising from the rider's judgement being impaired.

- Do not operate the vehicle while under the influence of alcohol, drugs and certain medications or physically or mentally impaired.



Danger

Danger of poisoning Exhaust gases are toxic and inhaling them may result in unconsciousness and/or death.

- When running the engine, always make sure there is sufficient ventilation, and do not start or run the engine in an enclosed space without an effective exhaust extraction system.



Warning

Danger of burns Some vehicle components become very hot when the vehicle is operated.

- Do not touch hot components such as exhaust system, radiator, engine, shock absorber, and the brake system. Allow these components to cool down before starting work on them.

Only operate the vehicle when it is in perfect technical condition, in accordance with its intended use, and in a safe and environmentally compatible manner.

The vehicle should only be used by trained persons. An appropriate driver's license is needed to ride the vehicle on public roads.

Have malfunctions that impair safety promptly eliminated by an authorized KTM workshop.

Adhere to the information and warning labels on the vehicle.

2.6 Protective clothing



Warning

Risk of injury Missing or poor protective clothing presents an increased safety risk.

- Wear protective clothing (helmet, boots, gloves, pants and jacket with protectors) every time you ride the vehicle. Always wear protective clothing that is in good condition and meets the legal requirements.

In the interest of your own safety, KTM recommends that you only operate the vehicle while wearing protective clothing.

2.7 Work rules

Special tools are necessary for certain tasks. The tools are not contained in the vehicle but can be ordered under the number in parentheses. E.g.: bearing puller (15112017000)

During assembly, non-reusable parts (e.g. self-locking screws and nuts, seals and seal rings, O-rings, pins, lock washers) must be replaced by new parts.

In some instances, a thread locker (e.g. **Loctite**®) is required. The manufacturer instructions for use must be followed.

After disassembly, clean the parts that are to be reused and check them for damage and wear. Change damaged or worn parts.

After you complete the repair or service work, check the operating safety of the vehicle.

2.8 Environment

If you use your motorcycle responsibly, you can ensure that problems and conflicts do not occur. To protect the future of the motorcycle sport, make sure that you use your motorcycle legally, display environmental consciousness, and respect the rights of others. When disposing of used oil, other operating and auxiliary fluids, and used components, comply with the laws and regulations of the respective country.

Because motorcycles are not subject to the EU regulations governing the disposal of used vehicles, there are no legal regulations that pertain to the disposal of an end-of-life motorcycle. Your authorized KTM dealer will be glad to advise you.

2.9 Owner's Manual

It is important that you read this Owner's Manual carefully and completely before making your first trip. The Owner's Manual contains useful information and many tips on how to operate, handle, and maintain your motorcycle. Only then will you find out how to customize the vehicle ideally for your own use and how you can protect yourself from injury.

Keep the Owner's Manual in an accessible place to enable you to refer to it as needed.

If you would like to know more about the vehicle or have questions on the material you read, please contact an authorized KTM dealer.

The Owner's Manual is an important component of the vehicle and should be handed over to the new owner if the vehicle is sold.

3.1 Guarantee, warranty

The work prescribed in the service schedule must be carried out by an authorized KTM workshop only and confirmed in the customer's Service & Warranty Booklet and in the **KTM Dealer.net**; otherwise, all warranty claims will be void. No warranty claims can be considered for damage resulting from manipulations and/or alterations to the vehicle.

Additional information on the guarantee or warranty and the procedures involved can be found in the Service & Warranty Booklet.

3.2 Operating and auxiliary substances



Warning

Environmental hazard Improper handling of fuel is a danger to the environment.

- Do not allow fuel to get into the ground water, the ground, or the sewage system.

Use operating and auxiliary substances (such as fuel and lubricants) as specified in the Owner's Manual.

3.3 Spare parts, accessories

For your own safety, only use spare parts and accessory products that are approved and/or recommended by KTM and have them installed by an authorized KTM workshop. KTM accepts no liability for other products and any resulting damage or loss.

Certain spare parts and accessory products are specified in parentheses in the descriptions. Your authorized KTM dealer will be glad to advise you.

The current **KTM PowerParts** for your vehicle can be found on the KTM website.

International KTM Website: <http://www.ktm.com>

3.4 Service

A prerequisite for perfect operation and prevention of premature wear is that the service, care, and tuning work on the engine and chassis is properly carried out as described in the Owner's Manual. Incorrect adjustment and tuning of the engine and chassis can lead to damage and breakage of components.

Use of the vehicle under difficult conditions, such in rain, high heat or with a heavy load, can lead to considerably more rapid wear of components such as the drive train, brake system, or suspension components. For this reason, it may be necessary to inspect or replace parts before the next scheduled service.

It is imperative that you adhere to the stipulated run-in times and service intervals. If you observe these exactly, you will ensure a much longer service life for your motorcycle.

3.5 Figures

The figures contained in the manual may depict special equipment.

In the interest of clarity, some components may be shown disassembled or may not be shown at all. It is not always necessary to disassemble the component to perform the activity in question. Please follow the instructions in the text.

3.6 Customer service

Your authorized KTM dealer will be happy to answer any questions you may have on your vehicle and KTM.

A list of authorized KTM dealers can be found on the KTM website.

International KTM Website: <http://www.ktm.com>

4 VIEW OF VEHICLE

4.1 View of vehicle, front left (example)

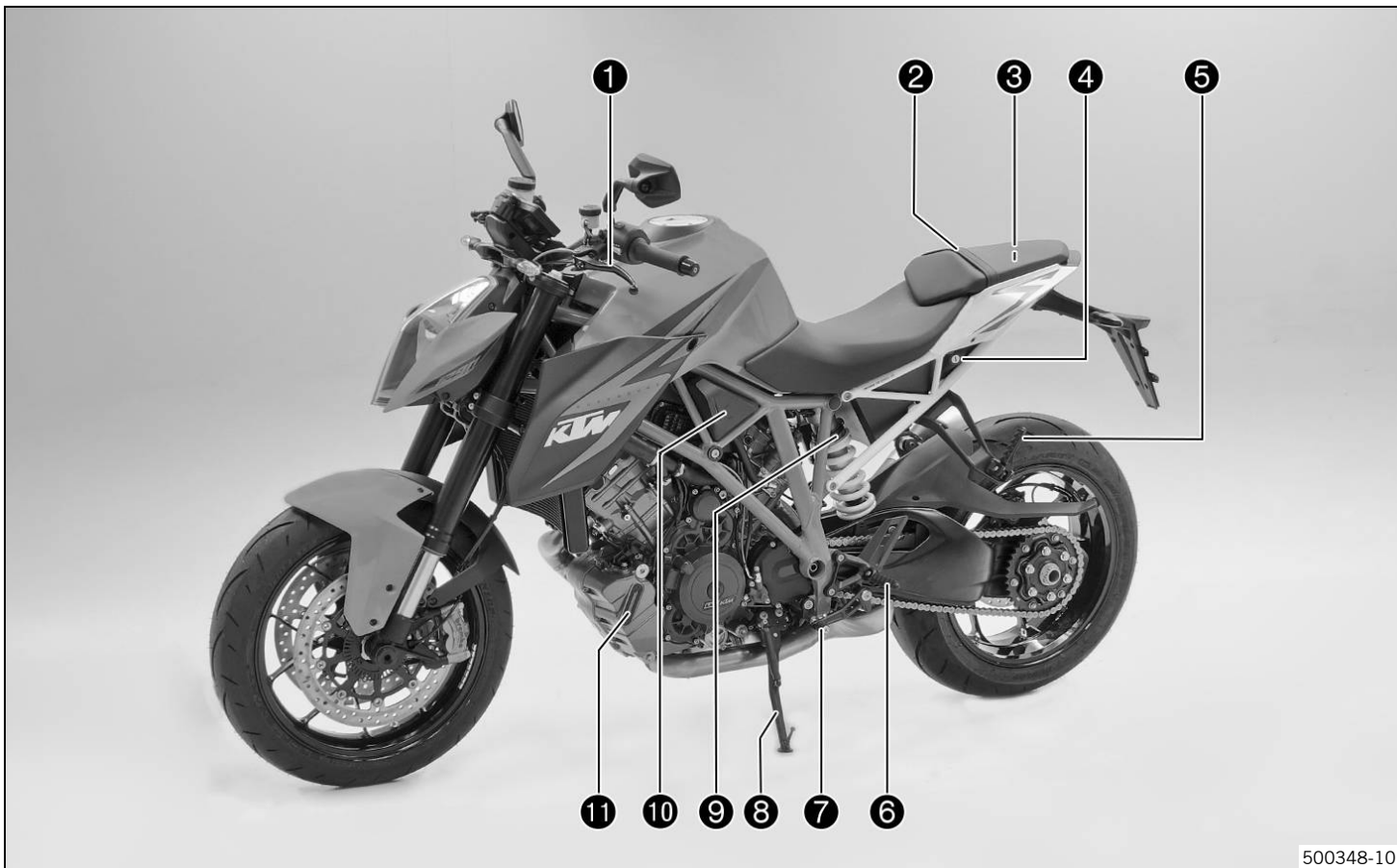

4 VIEW OF VEHICLE

1	Clutch lever (☛ p. 24)
2	Supporting strap (☛ p. 35)
3	Tool set (☛ p. 34)
4	Seat lock (☛ p. 33)
5	Passenger footrests (☛ p. 36)
6	Rider footrests
7	Shift lever (☛ p. 36)
8	Side stand (☛ p. 38)
9	Shock absorber, spring preload setting
10	Cooling system compensating tank
11	Engine oil level viewer

4 VIEW OF VEHICLE

4.2 View of vehicle, rear right (example)

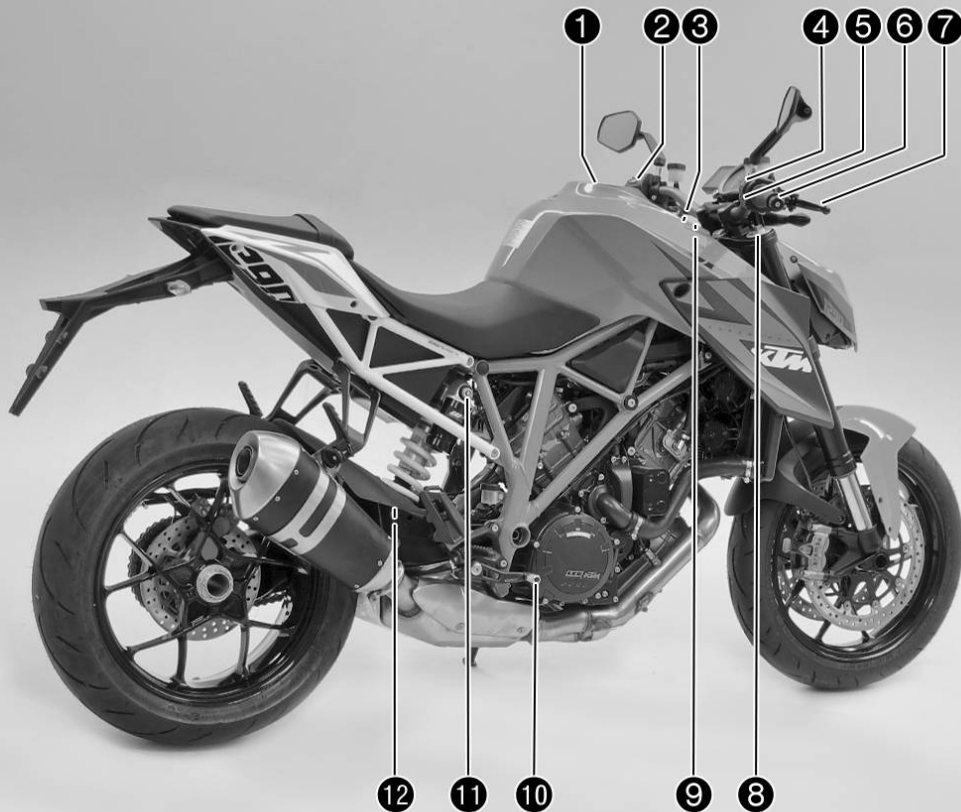

4 VIEW OF VEHICLE

1	Filler cap
2	Combination switch (☛ p. 25)
3	Ignition/steering lock (☛ p. 29)
4	Emergency OFF switch (☛ p. 28)
5	Electric starter button (☛ p. 29)
6	Throttle grip (☛ p. 25)
7	Hand brake lever (☛ p. 24)
8	Fork compression adjustment
9	Fork rebound adjustment
10	Foot brake lever (☛ p. 37)
11	Compression damping of the shock absorber (☛ p. 83)
12	Shock absorber rebound adjustment

5.1 Chassis number

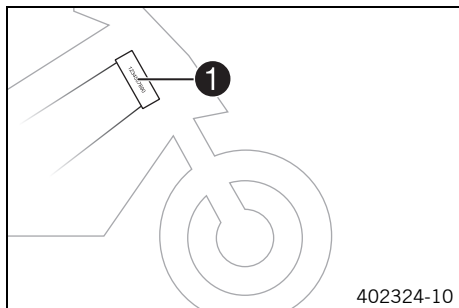

The chassis number **1** is stamped on the right side of the steering head.
The chassis number is also shown on the type label.

5.2 Type label

(1290 Super Duke R EU, 1290 Super Duke R FR)

The type label EU **1** is located on the steering head on the left.

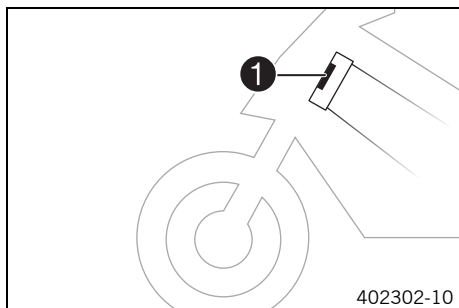

5 SERIAL NUMBERS

(1290 Super Duke R AUS)

The type label Australia **1** is located on the frame on the right.

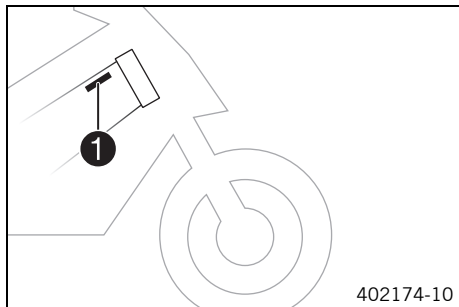

5.3 Key number

Key number **Code number 1** can be found on the **KEYCODECARD**.



Info

You need the key number to order a spare key. Keep the **KEYCODECARD** in a safe place.

With the orange programming key, you can activate or deactivate the black ignition key. Keep the orange programming key in a safe location; it may only be used for learning and programming functions.

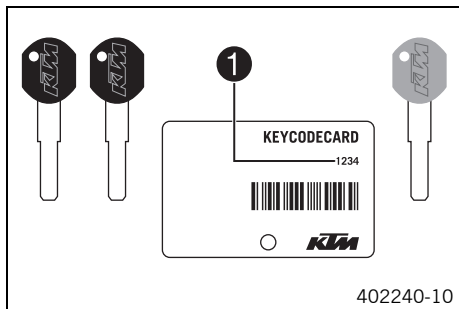

5.4 Engine number

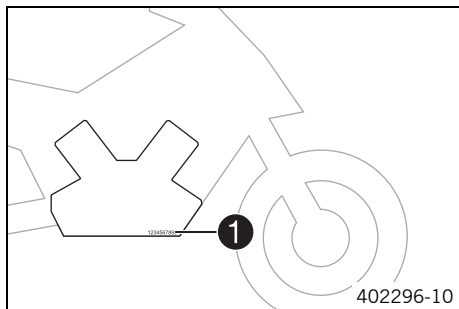

The engine number ❶ is stamped on the right side of the engine.

5.5 Fork part number

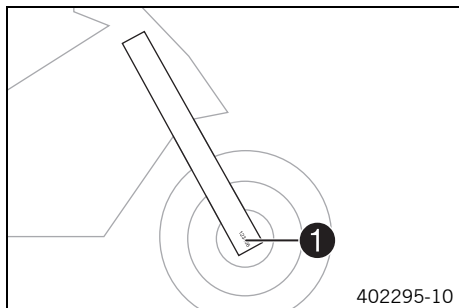

The fork part number ❶ is stamped on the inside of the axle clamp.

5.6 Shock absorber part number

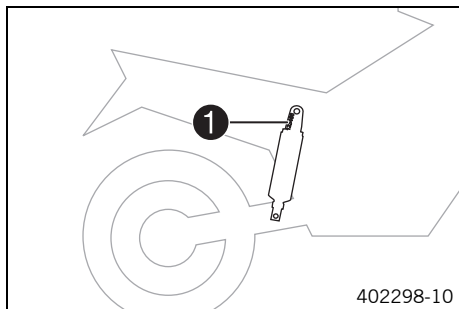

The shock absorber part number **1** is stamped on the top part of the shock absorber above the adjusting ring on the engine side.

5.7 Steering damper item number

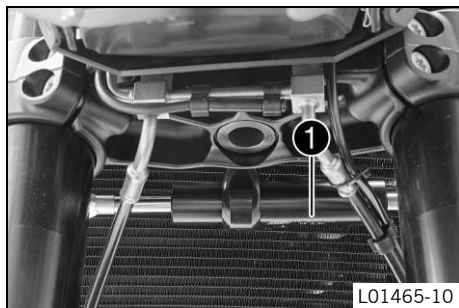

Steering damper item number **1** is embossed on the underside of the steering damper.

6.1 Clutch lever

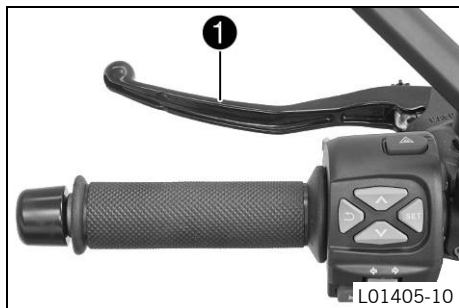

Clutch lever **1** is fitted on the handlebar on the left.
The clutch is activated hydraulically and adjusts itself automatically.

6.2 Hand brake lever

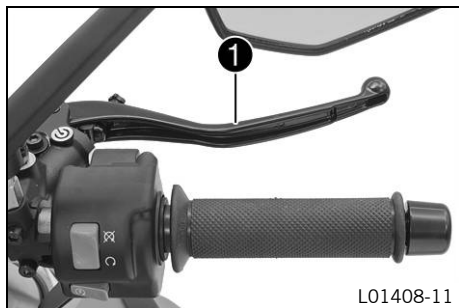

The hand brake lever **1** is fitted on the right side of the handlebar.
The front brake is engaged using the hand brake lever.

6.3 Throttle grip

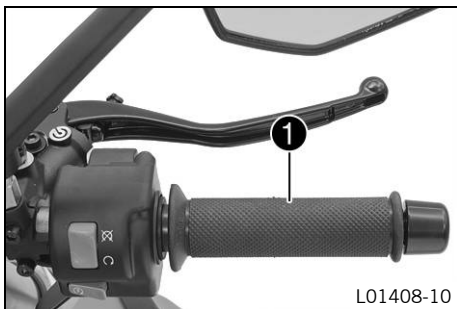

The throttle grip ❶ is fitted on the right side of the handlebar.

6.4 Switches on the left side of the handlebar

6.4.1 Combination switch

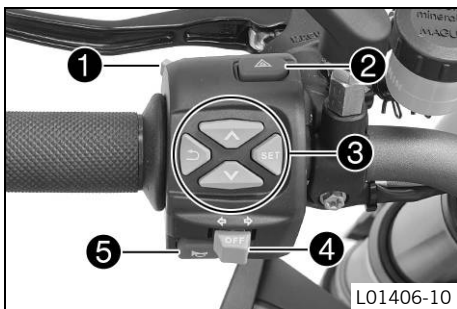

The combination switch is fitted on the left side of the handlebar.

Overview of the left combination switch

- | | |
|---|---|
| 1 | Light switch (☛ p. 26) |
| 2 | Hazard warning flasher switch (☛ p. 26) |
| 3 | Menu switch (☛ p. 27) |
| 4 | Turn signal switch (☛ p. 27) |
| 5 | Horn button (☛ p. 28) |

6.4.2 Light switch

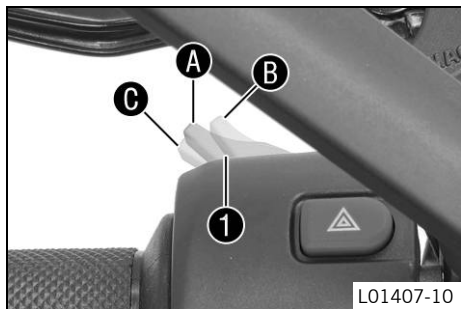

The light switch ❶ is fitted on the combination switch on the left.

Possible states

	Low beam on – Light switch in position ❶ A. In this position, the low beam and tail light are switched on.
	High beam on – Light switch in position ❶ B. In this position, the high beam and tail light are switched on.
	Headlight flasher – Push the light switch into position ❶ C.

6.4.3 Hazard warning flasher switch



The hazard warning flasher switch ❶ is fitted on the combination switch on the left. The hazard warning flasher is used to indicate emergency situations.



Info

The hazard warning flasher can be activated or deactivated while the ignition is switched on or up to 60 seconds after the ignition is switched off. Only keep the hazard warning flasher activated as long as necessary as it depletes the battery.

Possible states

	Hazard warning flasher on – All four turn signals and the green turn signal indicator lights in the combination instrument flash.
--	---

6.4.4 Menu switch

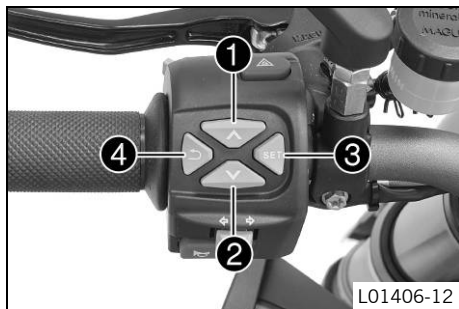

L01406-12

The menu switch is fitted in the middle of the left combination switch. The menu buttons are used to control the matrix display on the combination instrument.

Button **1** is the **UP** button.

Button **2** is the **DOWN** button.

Button **3** is the **SET** button.

Button **4** is the **BACK** button.



6.4.5 Turn signal switch



L01406-13

The turn signal switch **1** is fitted on the combination switch on the left.

Possible states

OFF	Turn signal off – Press the turn signal switch.
	Turn signal, left, on – Turn signal switch pressed to the left. The turn signal switch returns automatically to the central position after use.
	Turn signal, right, on – Turn signal switch pressed to the right. The turn signal switch returns automatically to the central position after use.



To switch off the turn signal, press the turn signal switch towards the switch case.

6.4.6 Horn button



The horn button ❶ is fitted on the combination switch on the left.

Possible states

- Horn button  in basic position.
- Horn button  pressed – The horn is operated in this position.

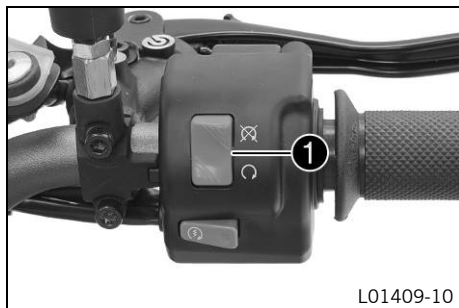

6.5 Switches on the right side of the handlebar

6.5.1 Emergency OFF switch



The emergency OFF switch ❶ is fitted on the right side of the handlebar.

Possible states

	<p>Emergency OFF switch off – In this position, the ignition circuit is interrupted, a running engine stops, and a non-running engine cannot be started. A message appears on the matrix display.</p>
	<p>Emergency OFF switch on – This position is required for operation; the ignition circuit is closed.</p>

6.5.2 Electric starter button



The electric starter button ❶ is fitted on the right side of the handlebar.

Possible states

- Electric starter button ❸ in basic position.
- Electric starter button ❸ is pressed – In this position, the electric starter is actuated.

6.6 Ignition/steering lock

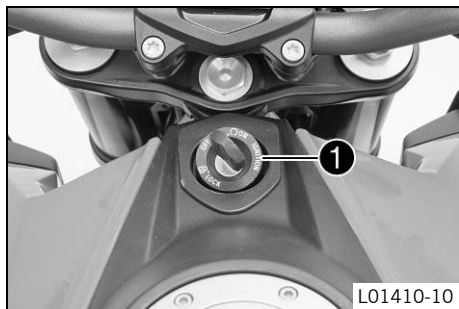

The ignition/steering lock ❶ is located in front of the upper triple clamp.



Info

The ignition may only be switched on using a black ignition key. With the orange programming key, you can activate or deactivate the black ignition key.

Possible states

	<p>Ignition off OFF – In this position, the ignition circuit is interrupted, a running engine stops, and a non-running engine will not start. The black ignition key can be removed.</p>
	<p>Ignition on ON – In this position, the ignition circuit is closed and the engine can be started.</p>
	<p>Steering locked – In this position, the ignition circuit is interrupted and the steering locked. The black ignition key can be removed.</p>

6.7 Immobilizer

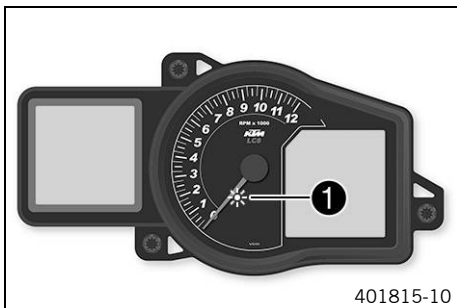

The electronic immobilizer secures the vehicle against unauthorized use. The immobilizer is activated automatically and the engine electronics are locked when the ignition key is withdrawn.

The immobilizer indicator lamp ❶ can indicate errors by flashing.

If the optional alarm system is installed, the immobilizer indicator lamp ❶ flashes when the alarm system is switched on.



Info

The ignition key contains electronic components. Never attach multiple ignition keys to a single key ring; this may cause mutual interference.

A lost black ignition key must be deactivated to prevent unauthorized persons from operating the vehicle.

The black ignition keys are activated when delivered.

Another two spare ignition keys (key number on the **KEYCODECARD**) can be ordered from an authorized KTM workshop; they need to be activated for use.

6.8 Opening the filler cap



Danger

Fire hazard Fuel is highly flammable.

- Never refuel the vehicle near open flames or burning cigarettes, and always switch off the engine first. Be careful that no fuel is spilt, especially on hot vehicle components. Clean up spilt fuel immediately.
- The fuel in the fuel tank expands when warm and may emerge if overfilled. Follow the instructions on refueling.



Warning

Danger of poisoning Fuel is poisonous and a health hazard.

- Fuel must not come into contact with the skin, eyes, or clothing. Do not breathe in the fuel vapors. If contact occurs with the eyes, rinse with water immediately and contact a physician. Immediately clean contaminated areas on the skin with soap and water. If fuel is swallowed, contact a physician immediately. Change clothing that is contaminated with fuel. Store fuel properly in a suitable canister and keep away from children.



Warning

Environmental hazard Improper handling of fuel is a danger to the environment.

- Do not allow fuel to get into the ground water, the ground, or the sewage system.

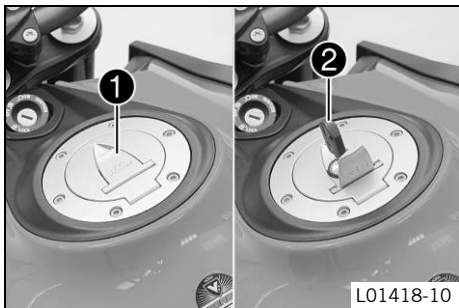

- Lift cover **1** of the filler cap and insert ignition key **2** in the fuel tank lock.

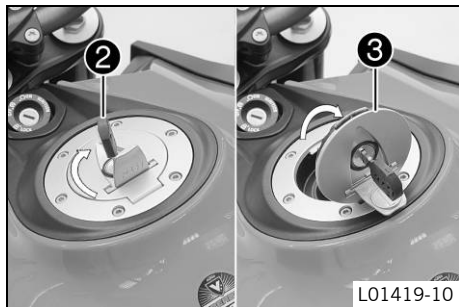

Note

Danger of damage Ignition key breakage.

- To take pressure off of the ignition key, push down on the filler cap. Damaged ignition keys must be replaced.

- Turn ignition key ② clockwise.
- Fold open filler cap ③.

6.9 Closing the filler cap

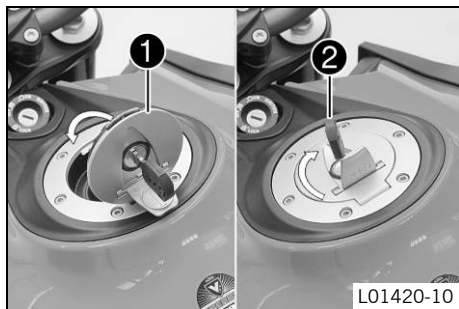

- Fold down filler cap ①.
- Turn ignition key ② clockwise.

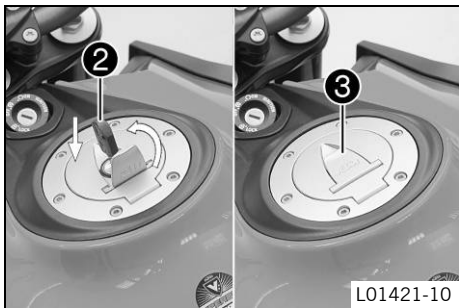

- Press down the filler cap and turn back ignition key ② until the fuel tank lock locks.



Warning

Fire hazard Fuel is highly flammable, poisonous and harmful to your health.

- After closing the filler cap, ensure that it is locked properly. Change clothing that has been contaminated with fuel. Immediately clean contaminated areas on the skin with soap and water.
-
- Remove ignition key ② and close cover ③.

6.10 Seat lock

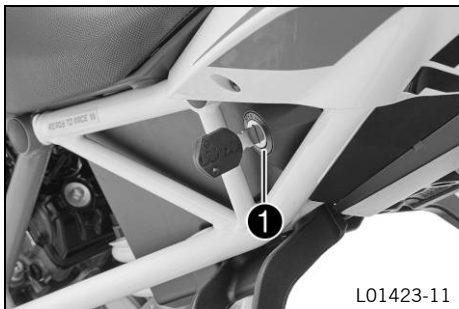

The seat lock ① is located on the left side of the vehicle. It can be unlocked using the ignition key.

6.11 Baggage lugs

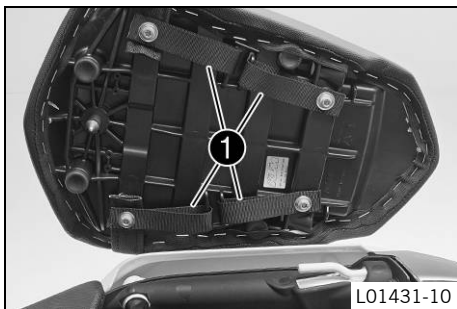

The baggage lugs **1** are located on the bottom of the passenger seat.



Info

When the passenger seat is mounted, the lugs are accessible if they are turned outward.

No more than one small piece of luggage with the specified weight may be attached to the turned-out baggage lugs.

Maximum luggage weight	5 kg (11 lb.)
------------------------	---------------

6.12 Tool set



The storage compartment under the passenger seat contains tool set **1**.

6.13 Supporting strap



The supporting strap ❶ is attached to the passenger seat. The supporting strap is provided for the passenger to hold on to.

6.14 Helmet lock



Warning

Danger of accidents Impairment of vehicle handling and vehicle operation if a helmet or helmet lock is attached to the vehicle.

- Do not use the helmet lock for holding a helmet or other objects during the journey. Always remove the helmet lock before starting out.

The steel cable ❶ in the tool set can be used to lock a helmet to the vehicle to prevent it from being stolen.

6.15 Passenger footrests

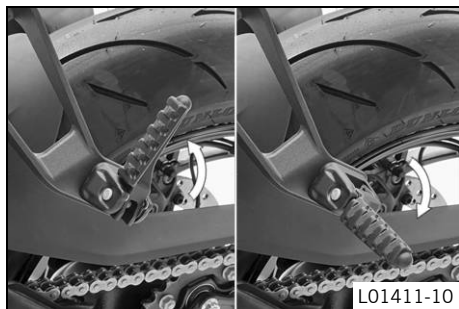

The passenger footrests can be folded up and down.

Possible states

- Passenger footrests folded up – For operation without a passenger.
- Passenger footrests folded down – For operation with a passenger.

6.16 Shift lever

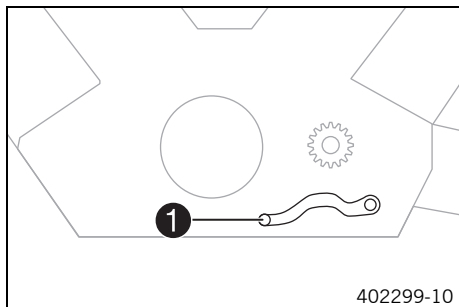

The shift lever **1** is fitted on the left side of the engine.

6 CONTROLS

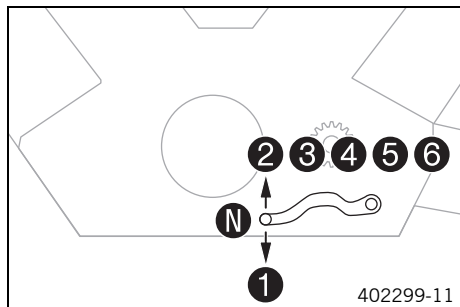

The gear positions can be seen in the figure.
The idle position is between the first and second gears.

6.17 Foot brake lever

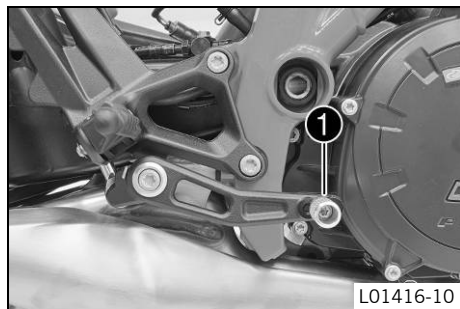

Foot brake lever ① is located in front of the right footrest.
The rear brake is engaged with the foot brake lever.

6.18 Side stand

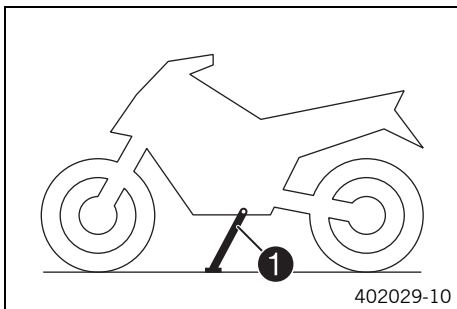

The side stand **1** is located on the left side of the vehicle.
The side stand is used for parking the motorcycle.



Info

The side stand must be folded up during motorcycle use.
The side stand is coupled with the safety starting system; see the instructions in the "Stopping, parking" chapter.

Possible states

- Side stand folded out – The vehicle can be supported on the side stand. The safety starting system is active.
- Side stand folded in – This position is mandatory when riding the motorcycle. The safety starting system is inactive.

7.1 Overview

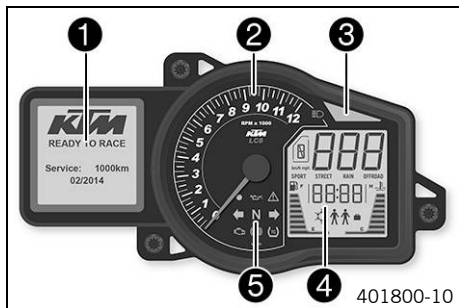

- 1 Matrix display (☛ p. 40)
- 2 Tachometer
- 3 Shift warning light (☛ p. 43)
- 4 Segment display
- 5 Indicator lamps (☛ p. 41)

7.2 Activation and test



Activation

The combination instrument is activated when the ignition is switched on.

i Info

The brightness of the displays is controlled by a brightness sensor in the combination instrument.

Test

The segment display, the indicator lamps, and the tachometer are briefly activated for a function test.

The welcome text and information on the next service (☛ p. 44) appear on the matrix display.

i Info

If the battery was disconnected, the time and date must be set.

7.3 Matrix display

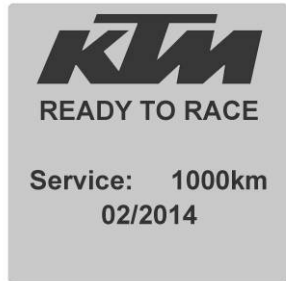

401821-01

The matrix display is controlled using the menu switch (☛ p. 27). After the ignition is switched on, the display shows when the next service (☛ p. 44) is due. If the General warning lamp  lights up among the indicator lamps (☛ p. 41), the corresponding message appears in the matrix display. The **Set** button is used to confirm receipt of the information and the message is cleared.

Messages appear	10 s
-----------------	------

7.4 Segment display













L01432-10

1	Fuel level
2	Time
3	Unit for the speedometer
4	Gear display
5	Speed
6	"Drive Mod" (☛ p. 153)
7	Coolant temperature
8	Ice warning

7.5 Indicator lamps









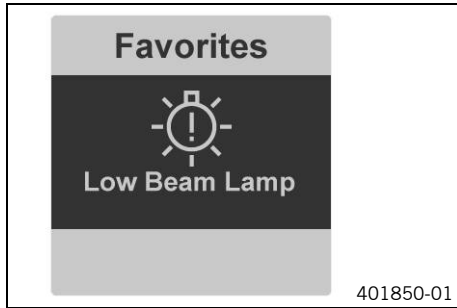



Possible states



	The high beam indicator lamp lights up blue – The high beam is switched on.
	The immobilizer indicator lamp lights up/ flashes red – Status or error message for immobilizer/ alarm system.
	The oil pressure warning lamp lights up red – Engine oil pressure is too low.
	The general warning lamp lights up yellow – An operating safety (warning) message was detected. This is also shown on the matrix display.
	The left turn signal lamp flashes green simultaneously with the turn signal – The left turn signal is switched on.
	The idle indicator lamp lights up green – The transmission is shifted to idle.
	The right turn signal lamp flashes green simultaneously with the turn signal – The right turn signal is switched on.
	The engine warning lamp lights up/ flashes yellow – The engine control unit has detected a fault.
	The ABS lamp lights up/ flashes yellow – ABS is not active. The ABS lamp also lights up when a fault is detected.
	The TC lamp lights up/ flashes yellow – Traction control is not enabled or is currently intervening. The TC lamp also lights up when a fault is detected.

7.6 Message on the matrix display



Possible states

	Engine malfunction – The engine control unit has detected a fault. Visit an authorized KTM workshop.
	General message – General message on operating safety. Visit an authorized KTM workshop.
	ABS warning – ABS is not available. Visit an authorized KTM workshop.
	Traction control – Traction control is not available. Visit an authorized KTM workshop.
	Engine oil pressure – Engine oil pressure is too low. Switch off the engine immediately. Contact an authorized KTM workshop.
	Engine oil level – The engine oil level is too low. Check the engine oil level and correct it.
	Lighting system – Lights up if an element of the lighting system has failed. Change the faulty light, or visit an authorized KTM workshop.
	Cooling water temperature – The cooling water temperature is too high. Switch off the engine. Contact an authorized KTM workshop.
	Fuel reserve – The fuel supply is dwindling. Refuel at the next opportunity.
	Icy road symbol – The roads may be icy. Adjust your speed to the road conditions.
	Battery voltage – The battery voltage is too low. Recharge the battery with a suitable battery charger.

	Service – A service is due. Contact an authorized KTM workshop.
	Emergency OFF switch – The emergency OFF switch is off.

The messages are displayed in the **"Warning"** menu.

7.7 Shift warning light

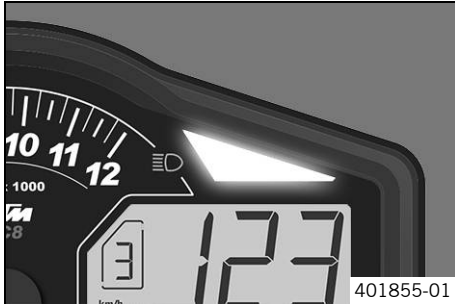

The shift warning light flashes or lights up when the transmission should be shifted. In the **"Shift Light"** menu, the engine speed for the shift warning light can be set. The shift warning light flashes at **"RPM1"** and lights up at **"RPM2"**.

Engine oil temperature	> 35 °C (> 95 °F)
"RPM1" shift warning light	Flashes
"RPM2" shift warning light	Lights up
Engine oil temperature	≤ 35 °C (≤ 95 °F)
The shift warning light always lights up at	6,500 rpm

7.8 Service display



401821-01

After the ignition is switched on, the service display appears briefly. The service intervals depend on the distance traveled or the elapsed time. The event that occurs first applies. The exact service intervals can be found in the service schedule.

7.9 Matrix display menu

7.9.1 "Favorites"

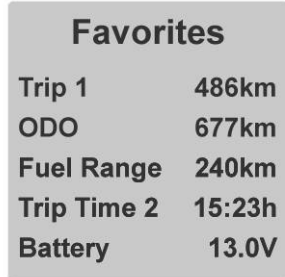

The image shows a rectangular matrix display menu. The title 'Favorites' is at the top. Below it, there are five rows of information:

Trip 1	486km
ODO	677km
Fuel Range	240km
Trip Time 2	15:23h
Battery	13.0V

L01440-10

- Press the **UP** or **DOWN** button until the "**Favorites**" menu appears on the matrix display. Pressing the **SET** button opens the menu.
- Press the **UP** or **DOWN** button to select the menu item and activate it with the **SET** button.
- Pressing the **BACK** button twice always opens the "**Favorites**" menu.

You can directly open five menus in the "**Favorites**" menu. The "**Favorites**" menu can be configured in the "**Set Favorites**" menu.

7.9.2 "Trip 1"

Trip 1	
Trip 1	973km
Ø Speed 1	89km/h
Ø Cons 1	10.3l
Trip Time 1	15:23h
Fuel Range	240km

401826-01

- Press the **UP** or **DOWN** button until the **"Trip 1"** menu appears on the matrix display. **"Trip 1"** shows the distance since the last reset, such as between two refueling stops. **"Trip 1"** runs continuously and counts the distance up to **9999**. **"Ø Speed 1"** indicates the average speed based on **"Trip 1"** and **"Trip Time 1"**. **"Ø Cons 1"** indicates the average fuel consumption based on **"Trip 1"** and **"Trip Time 1"**. **"Trip Time 1"** indicates the riding time based on **"Trip 1"** and starts running as soon as a speed signal comes in. **"Fuel Range"** indicates the possible range with the fuel reserve.

Press and hold the SET button for 3–5 seconds.	All entries in the "Trip 1" menu are cleared.
---	--

7.9.3 "Trip 2"

Trip 2	
Trip 2	973km
Ø Speed 2	89km/h
Ø Cons 2	10.3l
Trip Time 2	15:23h
Fuel Range	240km

401825-01

- Press the **UP** or **DOWN** button until the **"Trip 2"** menu appears on the matrix display. **"Trip 2"** shows the distance since the last reset, such as between two refueling stops. **"Trip 2"** runs continuously and counts the distance up to **9999**. **"Ø Speed 2"** indicates the average speed based on **"Trip 2"** and **"Trip Time 2"**. **"Ø Cons 2"** indicates the average fuel consumption based on **"Trip 2"** and **"Trip Time 2"**. **"Trip Time 2"** indicates the riding time based on **"Trip 2"** and starts running as soon as a speed signal comes in. **"Fuel Range"** indicates the possible range with the fuel reserve.

Press and hold the SET button for 3–5 seconds.	All entries in the "Trip 2" menu are cleared.
---	--

7.9.4 "General Info"

General Info

Air Temp	14.0°C
Date	01.04.2013
ODO	677km
Battery	13.0V
Oil Temp	75°C

401824-01

- Press the **UP** oder **DOWN** button until the "**General Info**" menu appears on the matrix display.

"**Air Temp**" indicates the ambient air temperature.

"**Date**" indicates the date.

"**ODO**" indicates the total distance covered.

"**Battery**" indicates the battery voltage.

"**Oil Temp**" indicates the engine oil temperature.

7.9.5 "Set Favorites"

Set Favorites

Trip 1	486km
ODO	677km
Fuel Range	240km
Trip Time 2	15:23h
Battery	13.0V

L01441-10

Condition

- The vehicle is stationary.

- Press the **UP** or **DOWN** button until the "**Set Favorites**" menu appears on the matrix display. Pressing the **SET** button opens the menu.
- Press the **UP** or **DOWN** button to select the menu. Press the **SET** button to set the menu for quick selection.

The "**Favorites**" menu can be configured in the "**Set Favorites**" menu.

7.9.6 "Settings"

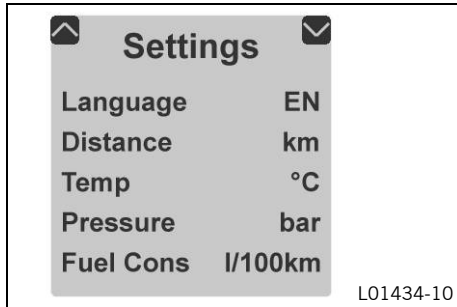

Condition

- The vehicle is stationary.
- Press the **UP** or **DOWN** button until the **"Settings"** menu appears on the matrix display. Pressing the **SET** button opens the menu.

Setting for units or various values are made in the **"Settings"** menu. Several functions can be enabled or disabled.

7.9.7 "Warning"

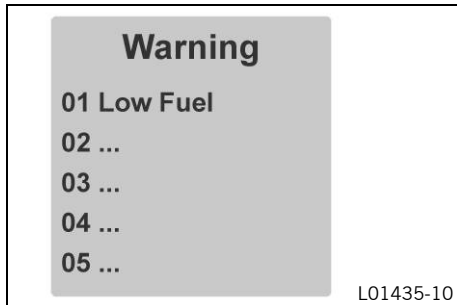

Condition

- Message or warning
- Press the **UP** or **DOWN** button until the **"Warning"** menu appears on the matrix display. Pressing the **SET** button opens the menu.
- Use the **UP** or **DOWN** button to navigate through the warnings.

In the **"Warning"** menu, warnings that occurred are displayed and stored until they are no longer active.

7.9.8 "Heat Grip" (optional)

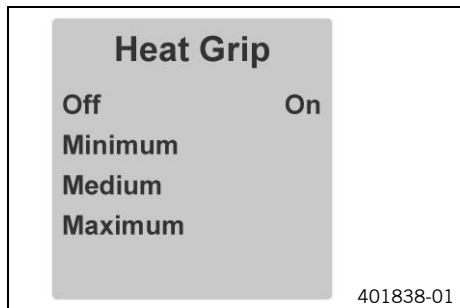

- Press the **UP** or **DOWN** button until the **"Heat Grip"** menu appears on the matrix display. Pressing the **SET** button opens the menu.
- Use the **UP** or **DOWN** button to navigate through the menu. Use the **SET** button to select a heating level or to switch off the heated grips.

7.9.9 "MTC/ABS"

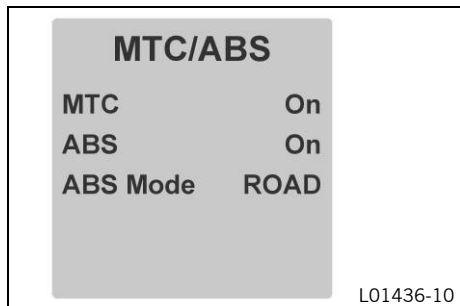

Condition

- The vehicle is stationary.
- Press the **UP** or **DOWN** button until the **"MTC/ABS"** menu appears on the matrix display. In the **"MTC/ABS"** menu, **"MTC"** and **"ABS"** can be switched off. In **"ABS Mode"**, a choice can be made between **"Road"** and **"SUP MOT"**.



Info

After the ignition is switched on, traction control and ABS are enabled again. In the **"ROAD"** ABS mode, the ABS controls both wheels. In the **"SUP MOT"** ABS mode, the ABS only controls the front wheel. There is no ABS intervention on the rear wheel. The ABS lamp flashes slowly to remind you that the **"SUP MOT"** ABS mode is enabled. In the **"SUP MOT"** ABS mode, the rear wheel may block and there is a risk of crashing.

7.9.10 "Drive Mod"

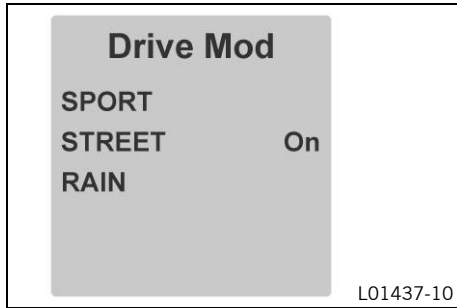

- Press the **UP** or **DOWN** button until the "**Drive Mod**" menu appears on the matrix display. Pressing the **SET** button opens the menu.
- Use the **UP** or **DOWN** button to navigate through the menu. The **SET** button can be used to select engine and traction control settings that are coordinated with each other.
 - ✓ SPORT – homologated performance with very direct response; the traction control allows greater slip on the rear wheel
 - ✓ STREET – homologated performance with balanced response; the traction control allows normal slip on the rear wheel
 - ✓ RAIN – reduced homologated performance for better rideability; the traction control allows normal slip on the rear wheel

7.9.11 Menu overview

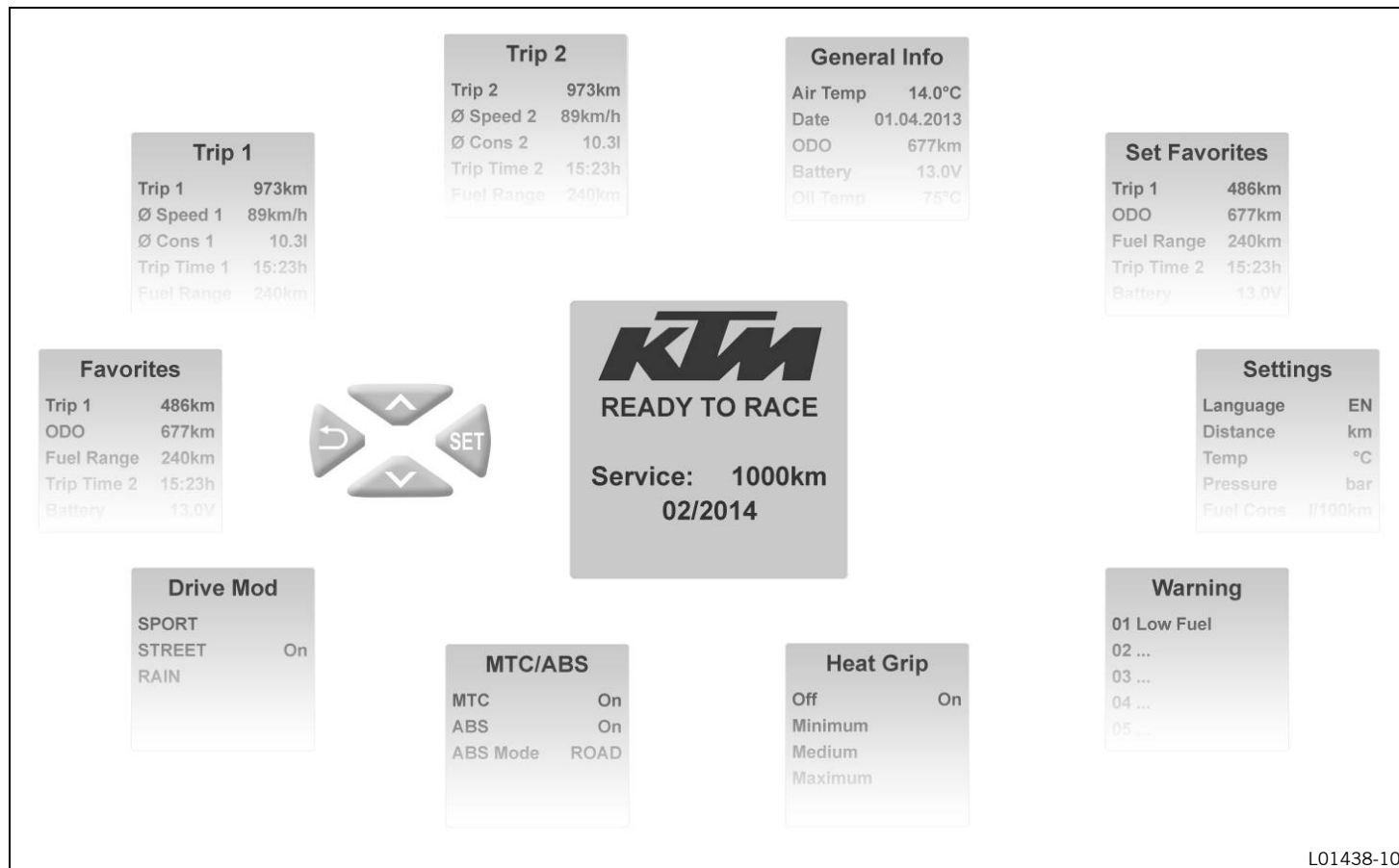

KTM start screen

Menu buttons

"Favorites"

"Trip 1"

"Trip 2"

"General Info"

"Set Favorites"

"Settings"

"Warning" (only active if there are messages)

"Heat Grip" (optional)

"MTC/ABS"

"Drive Mod"

7.9.12 "Language"

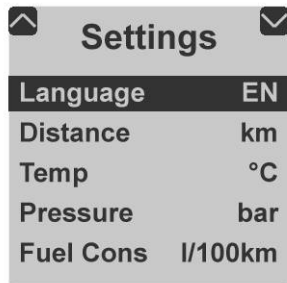

L01439-10

Condition

- The vehicle is stationary.
- Press the **UP** or **DOWN** button until the "**Settings**" menu appears on the matrix display. Pressing the **SET** button opens the menu.
- Press the **SET** button again to select the language.

The menu languages are English, German, Italian, French, and Spanish.

7.9.13 "Distance"

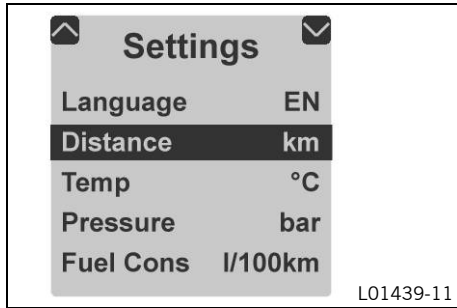

Condition

- The vehicle is stationary.
- Press the **UP** or **DOWN** button until the **"Settings"** menu appears on the matrix display. Pressing the **SET** button opens the menu.
- Press the **UP** or **DOWN** button until **"Distance"** is highlighted in black on the matrix display. Pressing the **SET** button again sets the unit of measure.

Select kilometers **"km"** or miles **"mi"** for the distance.

7.9.14 "Temp"

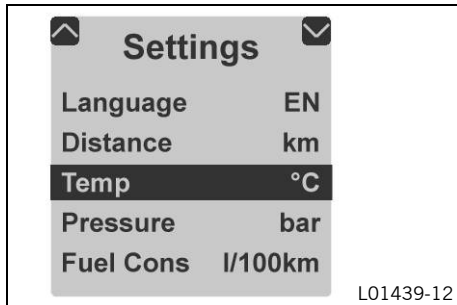

Condition

- The vehicle is stationary.
- Press the **UP** or **DOWN** button until the **"Settings"** menu appears on the matrix display. Pressing the **SET** button opens the menu.
- Press the **UP** or **DOWN** button until **"Temp"** is highlighted in black on the matrix display. Pressing the **SET** button again sets the unit of measure.

Select **"°C"** or **"°F"** for the temperature indicator.

7.9.15 "Pressure"

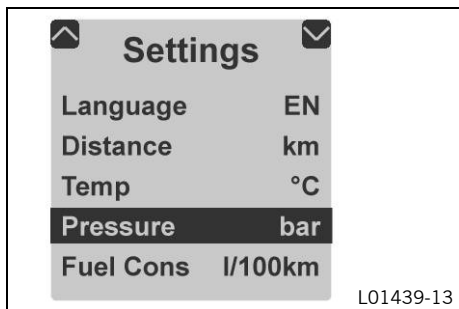

Condition

- The vehicle is stationary.
- Press the **UP** or **DOWN** button until the "**Settings**" menu appears on the matrix display. Pressing the **SET** button opens the menu.
- Press the **UP** or **DOWN** button until "**Pressure**" is highlighted in black on the matrix display. Pressing the **SET** button again sets the unit of measure.

Select "**bar**" or "**psi**" for the tire pressure display.

7.9.16 "Fuel Cons"

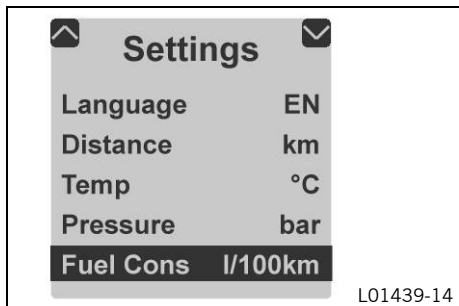

Condition

- The vehicle is stationary.
- Press the **UP** or **DOWN** button until the "**Settings**" menu appears on the matrix display. Pressing the **SET** button opens the menu.
- Press the **UP** or **DOWN** button until "**Fuel Cons**" is highlighted in black on the matrix display. Pressing the **SET** button again sets the unit of measure.

Select one of the available consumption displays.

7.9.17 "Clock/Date"

Clock/Date	
Hour	12
Minute	0
Day	1
Month	1
Year	2013

401990-01

Condition

- The vehicle is stationary.
- Press the **UP** or **DOWN** button until the **"Settings"** menu appears on the matrix display. Pressing the **SET** button opens the menu.
- Press the **UP** or **DOWN** button until **"Clock/Date"** is highlighted in black on the matrix display. Pressing the **SET** button again opens the menu.
- Use the **UP** or **DOWN** button to navigate through the menu. Use the **SET** button to set the time and date.

If the battery was disconnected, the time and date must be set in the matrix display.

7.9.18 "Shift Light"

Shift Light	
RPM1	8500
RPM2	10000
Shift Light	on

L01433-10

Condition

- The vehicle is stationary.
- Press the **UP** or **DOWN** button until the **"Settings"** menu appears on the matrix display. Pressing the **SET** button opens the menu.
- Press the **UP** or **DOWN** button until **"Shift Light"** is highlighted in black on the matrix display. Pressing the **SET** button again opens the menu.
- Press the **UP** or **DOWN** button to select the function. Use the **SET** button to set the engine speed for the shift warning light.

When the engine speed reaches **"RPM 1"**, the shift warning light flashes.

When the engine speed reaches **"RPM 2"**, the shift warning light lights up continuously.

Switch the **"Shift Light"** function on or off.

7.9.19 "Heat Grip"

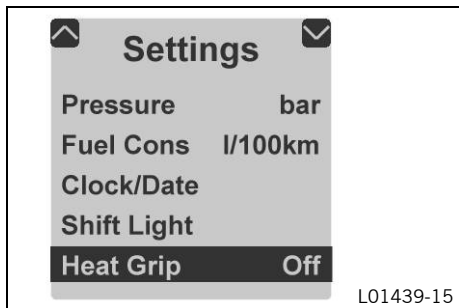

Condition

- The vehicle is stationary.
 - Press the **UP** or **DOWN** button until the "**Settings**" menu appears on the matrix display. Pressing the **SET** button opens the menu.
 - Press the **UP** or **DOWN** button until "**Heat Grip**" is highlighted in black on the matrix display. Pressing the **SET** button again switches the heat grips menu on or off.
- Switch the heat grips menu on and off.

7.9.20 "DRL"

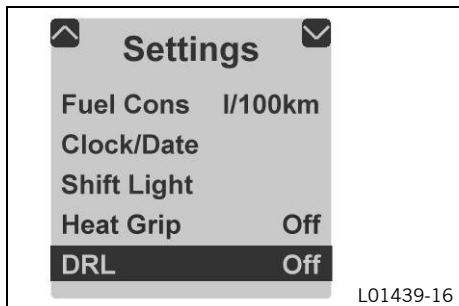

Condition

- The vehicle is stationary.
 - Press the **UP** or **DOWN** button until the "**Settings**" menu appears on the matrix display. Pressing the **SET** button opens the menu.
 - Press the **UP** or **DOWN** button until "**DRL**" is highlighted in black on the matrix display. Pressing the **SET** button again switches daytime running light on or off.
- Switch the daytime running light on or off.



Info

Note the legal regulations regarding the daytime running light.

8.1 Handlebar position

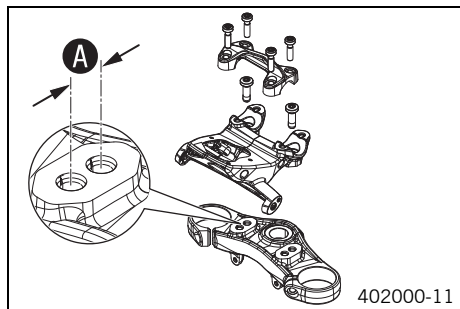

On the upper triple clamp there are two holes a distance of **A** apart.

Hole distance A	15 mm (0.59 in)
------------------------	-----------------

The handlebar can be mounted in two different positions. In this way, the handlebar can be mounted in the position that is most comfortable for the rider.



Info

KTM recommends the front handlebar position when using the vehicle on a race track.

8.2 Adjusting the handlebar position



Warning

Danger of accidents Handlebar breakage.

- If the handlebar is bent or straightened it will cause material fatigue, and the handlebar can break. Always replace handlebar.

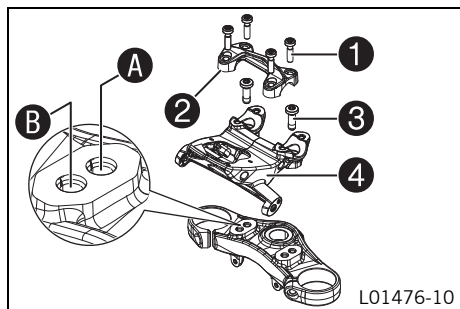

- Remove screws **1**. Take off handlebar clamp **2**. Position the handlebar so that screws **3** are accessible.



Info

Protect the components against damage by covering them. Do not kink the cables and lines.

- Remove screws **3**. Take off instrument support **4**.
- Move the instrument support into the desired position **A** or **B**. Mount and tighten screws **3**.

Guideline

Screw, instrument support	M10	40 Nm (29.5 lbf ft)	Loctite® 243™
---------------------------	-----	------------------------	---------------

- Position the handlebar.



Info

Make sure the cables and wiring are positioned correctly.

- Position the handlebar clamp. Mount and evenly tighten screws **1**.

Guideline

Screw, handlebar clamp	M8	20 Nm (14.8 lbf ft)
------------------------	----	------------------------

8.3 Setting the basic setting of the clutch lever

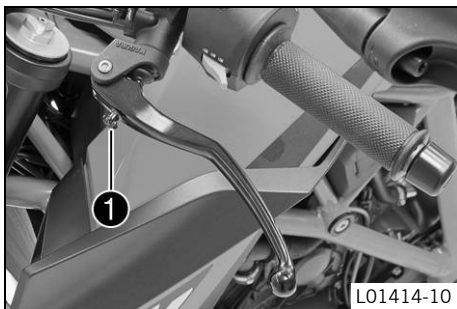

- Adjust the basic setting of the clutch lever to your hand size by turning adjusting screw **1**.



Info

Turn the adjusting screw clockwise to increase the distance between the clutch lever and the handlebar.
 Turn the adjusting screw counterclockwise to decrease the distance between the clutch lever and the handlebar.
 The range of adjustment is limited.
 Turn the adjusting screw by hand only, and do not apply any force.
 Push the clutch lever forward and turn the adjusting wheel.
 Do not make any adjustments while riding.

8.4 Adjusting the basic position of the hand brake lever



- Adjust the basic position of the hand brake lever to your hand size by turning adjusting wheel ❶.

i Info

Turn the adjusting screw clockwise to increase the distance between the hand brake lever and the handlebar.
Turn the adjusting screw counterclockwise to decrease the distance between the hand brake lever and the handlebar.
The range of adjustment is limited.
Turn the adjusting screw by hand only, and do not apply any force.
Push the hand brake lever forward and turn the adjusting wheel.
Do not make any adjustments while riding.

8.5 Adjusting the basic position of the foot brake lever

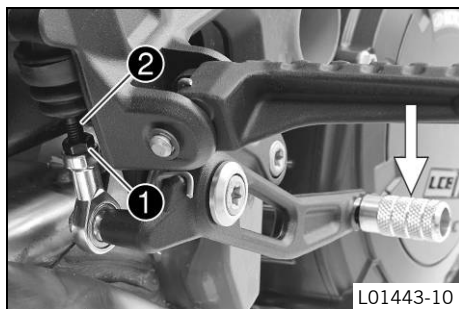

- Loosen nut ❶.
- Press the foot brake lever down to be able to turn push rod ❷ more easily.
- Turn the push rod until the foot brake lever is in the desired position.

i Info

The range of adjustment is limited.
The screw must be screwed into the ball joint by at least five turns.

- Lock nut ❶.

8.6 Setting the step plate of the foot brake lever

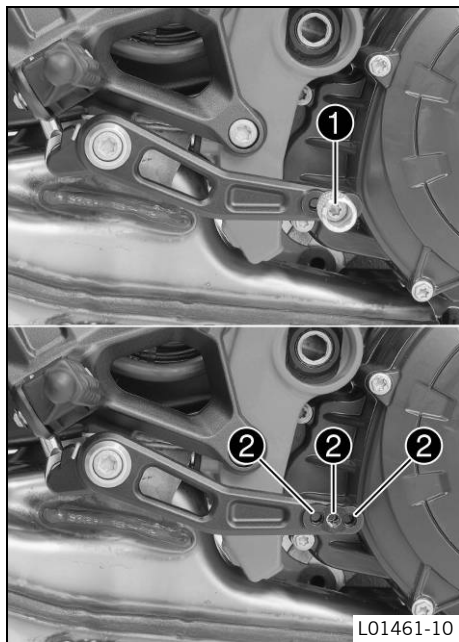

- Remove screw ❶ together with the foot plate of the foot brake lever.
- To adjust the length of the foot brake lever, position the step plate of the foot brake lever using screw ❶ in a drill hole ❷.

Guideline

Standard	Middle hole
----------	-------------

- Tighten screw ❶.

Guideline

Screw, step plate for foot brake lever	M6	10 Nm (7.4 lbf ft)	Loctite® 243™
--	----	-----------------------	---------------

8.7 Checking the basic position of the shift lever

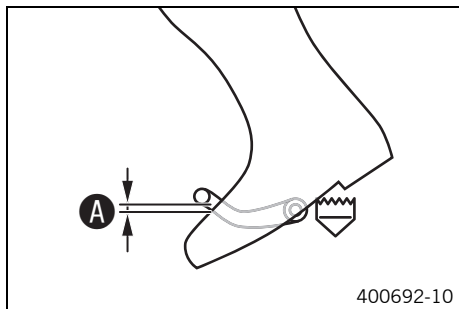

- Sit on the vehicle in the riding position and determine distance **A** between the upper edge of your boot and the shift lever.

Distance between shift lever and upper edge of boot	10... 20 mm (0.39... 0.79 in)
---	-------------------------------

- » If the distance does not meet specifications:
 - Adjust the basic position of the shift lever. 🛠️ (📄 p. 60)

8.8 Adjusting the basic position of the shift lever 🛠️

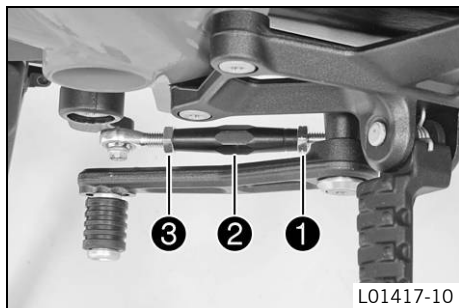

- Loosen nut **1**, holding the threaded rod **2**.

i **Info**
Nut **1** has a left-handed thread.

- Loosen nut **3**, holding the threaded rod **2**.
- Turn threaded rod **2** to adjust the shift lever.

i **Info**
The range of adjustment is limited.
The shift lever must not come into contact with any other vehicle components during the shift procedure.

- Tighten nut **3**, holding the threaded rod **2**.

Guideline

Nut, shift rod	M8	12 Nm (8.9 lbf ft)
----------------	----	--------------------

- Tighten nut ❶, holding the threaded rod ❷.

Guideline

Nut, shift rod	M8LH	12 Nm (8.9 lbf ft)
----------------	------	--------------------

8.9 Setting the shift lever stub

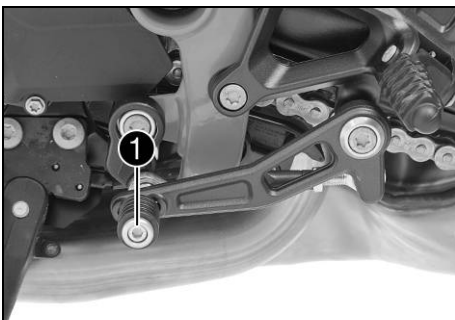

- Remove screw ❶ along with the shift lever stub.
- Position the shift lever stub with the screw in one of the drilled holes ❷ depending on the desired lever length.

Guideline

Standard	Middle hole
----------	-------------

- Tighten the screw.

Guideline

Screw, shift lever stub	M6	10 Nm (7.4 lbf ft)	Loctite® 243™
-------------------------	----	-----------------------	---------------

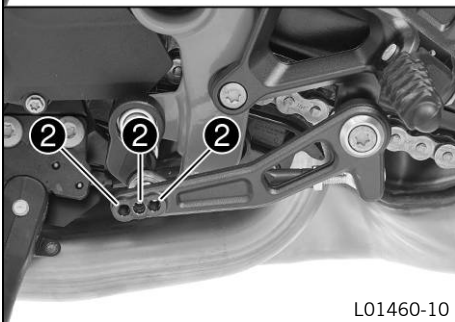

L01460-10

9.1 Advice on first use



Danger

Danger of accidents Danger arising from the rider's judgement being impaired.

- Do not operate the vehicle while under the influence of alcohol, drugs and certain medications or physically or mentally impaired.



Warning

Risk of injury Missing or poor protective clothing presents an increased safety risk.

- Wear protective clothing (helmet, boots, gloves, pants and jacket with protectors) every time you ride the vehicle. Always wear protective clothing that is in good condition and meets the legal requirements.



Warning

Danger of crashing Poor vehicle handling due to different tire tread patterns on front and rear wheels.

- The front and rear wheels must be fitted with tires with similar tread patterns to prevent loss of control over the vehicle.



Warning

Danger of accidents Uncontrollable handling characteristic due to non-approved and/or non-recommended tires/wheels.

- Only tires/wheels approved by KTM and with the corresponding speed index should be used.



Warning

Danger of accidents Reduced road grip with new tires.

- New tires have a smooth rolling surface and therefore cannot provide full road grip. The entire rolling surface must be roughened in the first 200 kilometers (124.3 miles) by moderate riding at alternating angles. The full grip levels are not achieved until the tires have been run in.



Warning

Danger of accidents Failure of brake system.

- If the foot brake lever is not released, the brake linings drag continuously. The rear brake may fail due to overheating. Take your foot off the foot brake lever when you are not braking.



Info

When using your vehicle, remember that others may feel disturbed by excessive noise.

- Make sure that the pre-delivery inspection work has been carried out by an authorized KTM workshop.
 - ✓ You receive a delivery certificate and the Service and Warranty Booklet at vehicle handover.
- Before your first trip, read the entire Owner's Manual carefully.
- Get to know the controls.
- Adjust the motorcycle to your requirements, as described in the "Ergonomics" chapter.
- Get used to handling the motorcycle on a suitable piece of land before making a longer trip. Try also to ride as slowly as possible and in a standing position to get a better feeling for the motorcycle.
- Hold the handlebar firmly with both hands and keep your feet on the footrests when riding.
- Run the engine in.

9.2 Running in the engine

- During the running-in phase, do not exceed the specified engine speed.

Guideline

Maximum engine speed	
During the first: 1,000 km (620 mi)	6,500 rpm
After the first: 1,000 km (620 mi)	10,250 rpm

**Tip**

During the running-in phase, set the shift warning light to the specified engine speed.

- Avoid fully opening the throttle!

9.3 Loading the vehicle

**Warning**

Danger of accidents Unstable handling characteristics.

- Do not exceed the maximum permitted weight and axle loads. The overall weight consists of: motorcycle operational and with a full tank, driver and passenger with protective clothing and helmet, baggage.

**Warning**

Danger of accidents Unstable handling characteristics due to incorrect mounting of suitcase and/or tank rucksack.

- Mount and secure suitcase and tank rucksack according to the manufacturer's instructions.

**Warning**

Danger of accidents Unstable handling characteristics at high speed.

- Adapt your speed according to your payload. Ride more slowly if your motorcycle is loaded with cases or other baggage.
Maximum speed with luggage 130 km/h (80.8 mph)

**Warning**

Danger of accidents Destruction of luggage carrier system.

- If the motorcycle is fitted with luggage cases, note the manufacturer's specifications concerning the maximum payload.

**Warning**

Danger of accidents Poor visibility for other road users due to slipped baggage.

- If the tail light is covered, you are less visible to traffic behind you, especially in the dark. Check that your baggage is fixed properly at regular intervals.

9 PREPARING FOR USE

 **Warning**
Danger of accidents Changed handling characteristics and longer stopping distance with excessive payload.
– Adapt your speed according to your payload.

 **Warning**
Danger of accidents Unstable handling characteristics due to slipped baggage.
– Check the way your baggage is fixed regularly.

 **Warning**
Danger of burns A hot exhaust system can burn baggage.
– Fasten your baggage in such a way that it cannot be burned or singed by the hot exhaust system.

-
- If you take along luggage, it should be safely secured close to the middle of the vehicle and the weight must be evenly distributed between the front and rear wheels.
 - The maximum permissible weight and the maximum permissible axle loads must not be exceeded.

Guideline

Maximum permissible overall weight	406 kg (895 lb.)
Maximum permissible front axle load	160 kg (353 lb.)
Maximum permissible rear axle load	260 kg (573 lb.)

10.1 Checks and maintenance measures when preparing for use



Info

Before every trip, check the condition of the vehicle and ensure that it is roadworthy. The vehicle must be in perfect technical condition when it is being operated.

- Check the engine oil level. (☞ p. 154)
- Check the brake fluid level of the front brake. (☞ p. 109)
- Check the rear brake fluid level. (☞ p. 112)
- Check the front brake linings. (☞ p. 111)
- Check the brake linings of the rear brake. (☞ p. 115)
- Check that the brake system is functioning properly.
- Check the coolant level in the compensating tank. (☞ p. 150)
- Check the chain for dirt. (☞ p. 97)
- Check the chain tension. (☞ p. 99)
- Check the tire condition. (☞ p. 123)
- Check the tire air pressure. (☞ p. 125)
- Check the settings of all controls and ensure that they can be operated smoothly.
- Check that the electrical equipment is functioning properly.
- Check that luggage is properly secured.
- Check the setting of the rear mirror.
- Check the fuel level.

10.2 Starting

 **Danger**
Danger of poisoning Exhaust gases are toxic and inhaling them may result in unconsciousness and/or death.

- When running the engine, always make sure there is sufficient ventilation, and do not start or run the engine in an enclosed space without an effective exhaust extraction system.

 **Caution**
Danger of accidents If the vehicle is operated with a discharged battery or without a battery, electronic components and safety equipment may be damaged.



- Never operate the vehicle with a discharged battery or without a battery.

Note

Engine failure High engine speeds in cold engines have a negative effect on the service life of the engine.

- Always warm up the engine at low engine speeds.



- Press the emergency OFF switch to the position **ON** .
- Switch on the ignition by turning the black ignition key to the position **ON** .
- ✓ After you switch on the ignition, you can hear the fuel pump working for about two seconds. The function check of the combination instrument is run at the same time.
- ✓ The ABS lamp lights up and goes back out after starting off.
- Shift the transmission to idle **N**.
- ✓ The green idling speed indicator lamp **N** lights up.



- Press the electric starter button (⚡).

i Info

Do not press the electric starter button until the combination instrument function check is finished.

When starting, **DO NOT** open the throttle. If you open the throttle during the starting procedure, fuel is not injected by the engine management system and the engine cannot start.

Press the electric starter button (⚡) for at most 5 seconds. Wait for a least 5 seconds before trying again.

This motorcycle is equipped with a safety starting system. You can only start the engine if the transmission is in neutral or if the clutch lever is pulled when a gear is engaged. If the side stand is folded out and you shift into gear, the engine stops.

- Remove the motorcycle from the side stand.

10.3 Starting off

- Pull the clutch lever, shift into first gear, release the clutch lever slowly and at the same time open the throttle gently.

10.4 Shifting, riding



Warning

Danger of accidents Abrupt load alterations can cause the vehicle to get out of control.

- Avoid abrupt load alterations and sudden braking actions, and adapt your speed to the road conditions.



Warning

Danger of accidents If you change down at high engine speed, the rear wheel can lock up.

- Do not change into a low gear at high engine speed. The engine races and the rear wheel can lock up.



Warning

Danger of accidents Malfunctions caused by incorrect ignition key position.

- Do not change the ignition key position during a journey.



Warning

Danger of accidents Distraction from traffic activity by adjustments to the vehicle.

- Make all adjustments when the vehicle is at a standstill.



Warning

Risk of injury Falling off of the passenger.

- The passenger must be seated properly on the passenger seat and hold on to the front rider or the grab handles. The feet must be positioned on the passenger footrests. Note the regulations governing the minimum age of passengers.



Warning

Danger of accidents Danger of accidents caused by dangerous driving.

- Comply with traffic regulations and ride defensively and foresightedly to detect sources of danger early on.



Warning

Danger of accidents Reduced road grip with cold tires.

- On every journey, take the first miles carefully at moderate speed until the tires reach operating temperature and optimal road grip is ensured.



Warning

Danger of accidents Reduced road grip with new tires.

- New tires have a smooth rolling surface and therefore cannot provide full road grip. The entire rolling surface must be roughened in the first 200 kilometers (124.3 miles) by moderate riding at alternating angles. The full grip levels are not achieved until the tires have been run in.



Warning

Danger of accidents Unstable handling characteristics.

- Do not exceed the maximum permitted weight and axle loads. The overall weight consists of: motorcycle operational and with a full tank, driver and passenger with protective clothing and helmet, baggage.



Warning

Danger of accidents Unstable handling characteristics due to slipped baggage.

- Check the way your baggage is fixed regularly.



Warning

Danger of accidents Lack of roadworthiness.

- After a fall, check the vehicle as usual before preparing for use.

Note

Engine failure Unfiltered intake air has a negative effect on the service life of the engine.

- Never operate the vehicle without an air filter as dust and dirt will enter the engine and lead to increased wear.

Note

Engine failure Overheating of engine.

- If the coolant temperature warning lamp lights up, stop and switch off the engine. Allow the engine to cool down and check the coolant level in the radiator, and top up if necessary. If you continue with the coolant temperature warning lamp alight, you may have engine failure.



Info

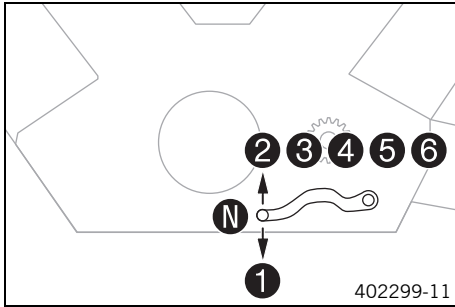

If you hear unusual noises while riding, stop immediately, switch off the engine and contact an authorized KTM workshop.



- When conditions allow (incline, road situation, etc.), you can shift into a higher gear.
- Release the throttle while simultaneously pulling the clutch lever, shift into the next gear, release the clutch lever, and open the throttle.

i Info

You can see the positions of the 6 forward gears in the figure. The idle position is between the first and second gears. First gear is used for starting off or for steep inclines.

-
- After reaching maximum speed by fully opening the throttle grip, turn the throttle back so it is $\frac{3}{4}$ open. This will barely reduce the speed but fuel consumption will be considerably lower.
 - Accelerate only up to a speed suitable for the road surface and weather conditions. Particularly in bends, do not shift, and accelerate very carefully.
 - To shift down, brake if necessary and close the throttle at the same time.
 - Pull the clutch lever and shift into a lower gear, release the clutch lever slowly, and open the throttle or shift again.
 - If the engine stalls (e.g. at a crossroads), just pull the clutch lever and press the electric starter button. You do not have to shift into neutral.
 - Switch off the engine if you expect to be standing for a long time.
 - If the oil pressure warning lamp  lights up during a trip, stop immediately and switch off the engine. Contact an authorized KTM workshop.
 - If the engine warning lamp  lights up during a trip, please contact an authorized KTM workshop as soon as possible.

i Info

From the flash rhythm you can deduce a two-digit number, the so-called blink code. The blink code tells you which component is affected by a malfunction.

-
- If the general warning lamp  lights up during a trip, the matrix display shows a message for 10 seconds.



Info

Very important messages are stored in the **"Warning"** menu.

- If the icy road symbol ❄ appears in the combination instrument, the roads may be icy. Adjust your speed to the road conditions.

10.5 Applying the brakes



Warning

Danger of accidents Reduced braking efficiency due to a wet or dirty brake system.

- Clean or dry a dirty or wet brake system by riding and braking gently.



Warning

Danger of accidents Reduced braking efficiency caused by spongy pressure point of front or rear brake.

- Check the brake system and do not continue riding. (Your authorized KTM workshop will be glad to help.)



Warning

Danger of accidents Failure of brake system.

- If the foot brake lever is not released, the brake linings drag continuously. The rear brake may fail due to overheating. Take your foot off the foot brake lever when you are not braking.



Warning

Danger of accidents Longer stopping distance due to higher overall weight.

- Take the longer stopping distance into account when carrying a passenger and baggage.



Warning

Danger of accidents Delayed brake action on salted roads.

- There may be salt deposits on the brake discs. In order to restore the normal braking efficiency, you will need to remove the deposits from the discs by carefully applying the brakes.



Warning

Danger of accidents Greater stopping distance due to ABS.

- Braking should be appropriate to the driving situation and the road conditions.



Warning

Danger of accidents Excessively forceful braking can cause the wheels to block.

- ABS must be switched on to be effective.



Warning

Danger of accidents Vehicle rollover

- It is not always possible to prevent vehicle rollover in extreme riding situations (e. g. luggage loaded with a high center of gravity, varying road surfaces, steep descents, full braking without disengaging the gear). Adapt your riding style to the road conditions and your riding ability.

-
- When braking, release the throttle and apply the front and rear brakes at the same time.



Info

When ABS is enabled, you can achieve maximum braking power even on low grip surfaces such as sandy, wet, or slippery terrain without locking of the wheels.



Warning

Danger of accidents Locking of the wheels due to braking action of the engine.

- Pull the clutch during emergency braking, full brake application and when braking on a slippery surface.



Warning

Danger of accidents Road grip is reduced when braking with the motorcycle at an angle or on a laterally inclined surface.

- Braking should be completed before you enter into a bend.

-
- Braking should always be completed before you go into a bend. Change down to a lower gear appropriate to your road speed.

- On long downhill stretches, use the braking effect of the engine. Change down one or two gears, but do not over-rev the engine. In this way, you have to brake far less and the brakes do not overheat.

10.6 Stopping, parking



Warning

Risk of misappropriation Usage by unauthorized persons.

- Never leave the vehicle while the engine is running. Secure the vehicle against use by unauthorized persons. If you leave the vehicle, lock the steering and remove the ignition key.



Warning

Danger of burns Some vehicle components become very hot when the vehicle is operated.

- Do not touch hot components such as exhaust system, radiator, engine, shock absorber, and the brake system. Allow these components to cool down before starting work on them.

Note

Danger of damage The parked vehicle may roll away or fall over.

- Always place the vehicle on a firm and even surface.

Note



Fire hazard Some vehicle components become very hot when the vehicle is operated.

- Do not park the vehicle near flammable or explosive substances. Do not place objects on the vehicle while it is still warm from being run. Always let the vehicle cool first.

Note

Material damage Damage to or destruction of components due to excessive load.



- The side stand is only designed for the weight of the motorcycle. Do not sit on the motorcycle when it is resting on the side stand. The side stand or the frame may become damaged and the motorcycle may fall over.
-

- Apply the brakes on the motorcycle.
- Shift the transmission to idle .
- Switch off the ignition by turning the black ignition key to the position **OFF** .



Info

If the engine is switched off with the emergency OFF switch and the ignition remains switched on at the ignition lock, power continues to flow to most power consumers. This discharges the battery. You should therefore always switch off the engine with the ignition key – the emergency OFF switch is intended for emergencies only.

- Park the motorcycle on a firm surface.
- Swing the side stand forward with your foot as far as it will go and lean the vehicle on it.
- Lock the steering by turning the handlebar to the left, pressing the black ignition key down in the position **OFF**  and turning it to the position **LOCK** . To make the steering lock engage more easily, move the handlebar a little to the left and right. Remove the black ignition key.

10.7 Transport

Note

Danger of damage The parked vehicle may roll away or fall over.

- Always place the vehicle on a firm and even surface.

Note

Fire hazard Some vehicle components become very hot when the vehicle is operated.

- Do not park the vehicle near flammable or explosive substances. Do not place objects on the vehicle while it is still warm from being run. Always let the vehicle cool first.

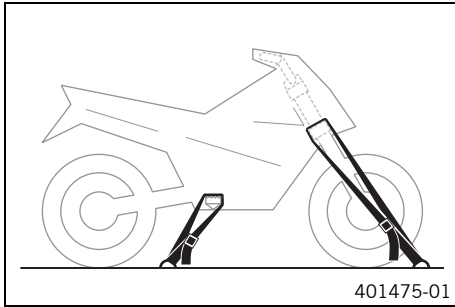

- Switch off the engine.
- Use tension belts or other suitable devices to secure the motorcycle against accidents or falling over.

10.8 Refueling



Danger

Fire hazard Fuel is highly flammable.

- Never refuel the vehicle near open flames or burning cigarettes, and always switch off the engine first. Be careful that no fuel is spilt, especially on hot vehicle components. Clean up spilt fuel immediately.
- The fuel in the fuel tank expands when warm and may emerge if overfilled. Follow the instructions on refueling.



Warning

Danger of poisoning Fuel is poisonous and a health hazard.

- Fuel must not come into contact with the skin, eyes, or clothing. Do not breathe in the fuel vapors. If contact occurs with the eyes, rinse with water immediately and contact a physician. Immediately clean contaminated areas on the skin with soap and water. If fuel is swallowed, contact a physician immediately. Change clothing that is contaminated with fuel.

Note

Material damage Premature clogging of the fuel filter.

- In some countries and regions, the available fuel quality and cleanliness may not be sufficient. This will result in problems with the fuel system. (Your authorized KTM workshop will be glad to help.)

10 RIDING INSTRUCTIONS

- Only refuel with clean fuel that meets the specified standards.



Warning

Environmental hazard Improper handling of fuel is a danger to the environment.

- Do not allow fuel to get into the ground water, the ground, or the sewage system.

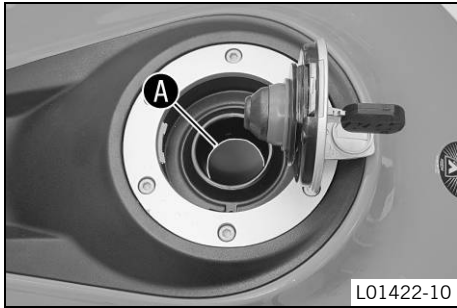

- Switch off the engine.
- Open the filler cap. (☛ p. 30)
- Fill the fuel tank with fuel up to the lower edge **A** of the filler neck.



Total fuel tank capacity, approx.	18 l (4.8 US gal)	Super unleaded (ROZ 95/RON 95/PON 91) (☛ p. 187)
-----------------------------------	-------------------	--

- Close the filler cap. (☛ p. 32)

11.1 Additional information

Any further work that results from the required work or from the recommended work must be ordered separately and can be invoiced separately.

11.2 Required work

	Every two years	Every year	Every 30,000 km (18,600 mi)	After 15,000 km (9,300 mi) / Every 15,000 km (9,300 mi)	After 1,000 km (620 mi)
Read out the fault memory using the KTM diagnostics tool. 	○	●	●	●	●
Check the fuel pressure. 		●	●	●	●
Check that the electrical equipment is functioning properly.	○	●	●	●	●
Change the engine oil and filter, clean the oil screens.  (🔧 p. 155)	○	●	●	●	●
Check the brake discs. (🔧 p. 108)	○	●	●	●	●
Check the front brake linings. (🔧 p. 111)	○	●	●	●	●
Check the brake linings of the rear brake. (🔧 p. 115)	○	●	●	●	●
Check the tire condition. (🔧 p. 123)	○	●	●	●	●
Check the tire air pressure. (🔧 p. 125)	○	●	●	●	●
Check the rear brake fluid level. (🔧 p. 112)	○	●	●	●	
Check the shock absorber and fork for leaks. Perform a fork service and shock absorber service as needed and depending on how the vehicle will be used.	○	●	●	●	●
Clean the dust boots of the fork legs.		●	●		
Check the chain, rear sprocket, engine sprocket, and chain guide. (🔧 p. 101)		●	●	●	●
Check the chain tension. (🔧 p. 99)	○	●	●	●	●

11 SERVICE SCHEDULE

	Every two years				
	Every year				
	Every 30,000 km (18,600 mi)				
	After 15,000 km (9,300 mi) / Every 15,000 km (9,300 mi)				
	After 1,000 km (620 mi)				
Check the brake lines for damage and leakage.	○	●	●	●	●
Check the brake fluid level of the front brake. (🔧 p. 109)	○	●	●	●	●
Check that the rear wheel nut (right side) is tightened to the specified torque.	○	●	●	●	●
Check the coolant level in the compensating tank. (🔧 p. 150)	○	●	●	●	●
Check that the radiator fan is functioning properly. 🛠️	○	●	●	●	●
Change the air filter, clean the air filter box. 🛠️		●	●		
Check the cables for damage and routing without sharp bends. (fuel tank removed) 🛠️		●	●	●	●
Change the spark plugs (air filter removed). 🛠️			●		
Check the valve clearance (air filter removed). 🛠️		○			
Check the valve clearance (air filter and spark plugs removed). 🛠️			●		
Change the secondary air system membranes. 🛠️			●		
Change the front brake fluid. 🛠️					●
Change the rear brake fluid. 🛠️					●
Check the steering head bearing play.	○	●	●	●	●
Check the headlight setting. (🔧 p. 143)	○	●	●		
Final check: Check the vehicle for roadworthiness and take a test ride.	○	●	●	●	●
Read out the error memory after the test ride using the KTM diagnostics tool. 🛠️	○	●	●	●	●
Check the CO adjustment with the KTM diagnostics tool. 🛠️	○	●	●		
Reset the service interval display.	○	●	●	●	●
Make the service entry in the KTM DEALER.NET and in the Service and Warranty Booklet. 🛠️	○	●	●	●	●

11 SERVICE SCHEDULE

- One-time interval
- Periodic interval

11.3 Recommended work

	Every four years				
	Every two years				
	Every year				
	Every 15,000 km (9,300 mi)				
	After 1,000 km (620 mi)				
Check/clean the oil nozzle for clutch lubrication. 🛠️	○	●			
Check the swingarm bearing.		●			
Check the wheel bearings.		●			
Grease all moving parts (e.g., side stand, hand lever, chain, ...) and check for smooth operation. 🛠️	○	●	●	●	●
Check all hoses (e.g. fuel, cooling, bleeder, drainage, etc.) and sleeves for cracking, leaks, and incorrect routing. 🛠️		●	●	●	●
Check the antifreeze. 🛠️	○	●	●	●	●
Check/rectify the fluid level of the hydraulic clutch. (📖 p. 104)		●	●		
Change the hydraulic clutch fluid. 🛠️				●	●
Check the screws and nuts for tightness. 🛠️	○	●	●	●	●
Change the coolant. 🛠️					●

- One-time interval
- Periodic interval

12.1 Fork/shock absorber



The fork and the shock absorber offer many options of adapting the suspension to the riding style and the payload.

i Info

The recommendations for the suspension setting are shown in Table 1. The table is located on the underside of the front rider's seat.

These adjustments are guidelines and should always be the basis for a suspension setting. If the guidelines are not adhered to, the riding characteristics could deteriorate, particularly at high speeds.

12.2 Adjusting the compression damping of the fork

i Info

The hydraulic compression damping determines the fork suspension behavior.

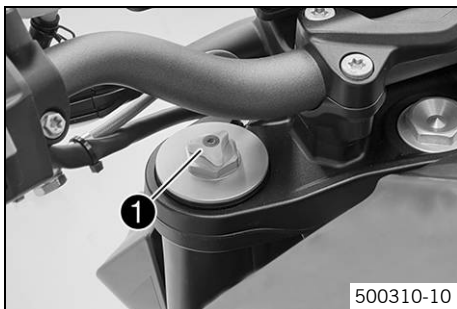

- Turn the white adjusting screw 1 all the way clockwise.

i Info

Adjusting screw 1 is located at the upper end of the left fork leg. The compression damping is located in the left fork leg **COMP** (white adjusting screw). The rebound damping is located in the right fork leg **REB** (red adjusting screw).

- Turn counterclockwise by the number of clicks corresponding to the fork type.

Guideline

Compression damping	
Comfort	17 clicks
Standard	12 clicks
Sport	7 clicks
Full payload	7 clicks



Info

Turn clockwise to increase damping; turn counterclockwise to reduce damping.

12.3 Adjusting the rebound damping of the fork



Info

The hydraulic rebound damping determines the fork suspension behavior.



- Turn the red adjusting screw **1** all the way clockwise.



Info

Adjusting screw **1** is located at the upper end of the right fork leg. The rebound damping is located in the right fork leg **REB** (red adjusting screw). The compression damping is located in the left fork leg **COMP** (white adjusting screw).

- Turn counterclockwise by the number of clicks corresponding to the fork type.

Guideline

Rebound damping	
Comfort	17 clicks
Standard	12 clicks
Sport	7 clicks
Full payload	7 clicks



Info

Turn clockwise to increase damping; turn counterclockwise to reduce damping.

12.4 Compression damping of the shock absorber



The compression damping of the shock absorber is divided into two ranges: high-speed and low-speed.

High-speed and low-speed refer to the compression speed of the rear wheel suspension and not to the vehicle speed.

The high-speed setting, for example, has an effect on the landing after a jump: the rear wheel suspension compresses more quickly.

The low-speed setting, for example, has an effect when riding over long ground swells: the rear wheel suspension compresses more slowly.

These two ranges can be adjusted separately, although the transition between high-speed and low-speed is gradual. Thus, changes in the high-speed range affect the compression damping in the low-speed range and vice versa.

12.5 Adjusting the low-speed compression damping of the shock absorber



Caution

Danger of accidents Disassembly of pressurized parts can lead to injury.

- The shock absorber is filled with high density nitrogen. Adhere to the description provided. (Your authorized KTM workshop will be glad to help.)



Info

The low-speed setting takes effect during the slow to normal compression of the shock absorber.

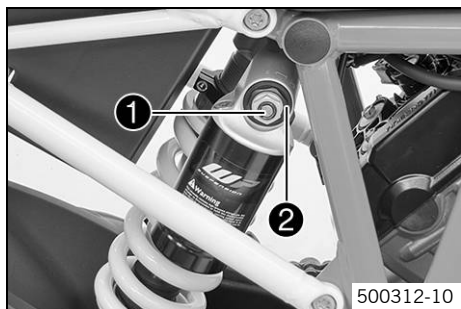

- Turn adjusting screw ❶ clockwise with a screwdriver up to the last perceptible click.



Info

Do not loosen fitting ❷!

- Turn counterclockwise by the number of clicks corresponding to the shock absorber type.

Guideline

Compression damping, low-speed	
Comfort	18 clicks
Standard	15 clicks
Sport	10 clicks
Full payload	10 clicks



Info

Turn clockwise to increase damping; turn counterclockwise to reduce damping.

12.6 Adjusting the high-speed compression damping of the shock absorber



Caution

Danger of accidents Disassembly of pressurized parts can lead to injury.

- The shock absorber is filled with high density nitrogen. Adhere to the description provided. (Your authorized KTM workshop will be glad to help.)



Info

The high-speed setting takes effect during the fast compression of the shock absorber.

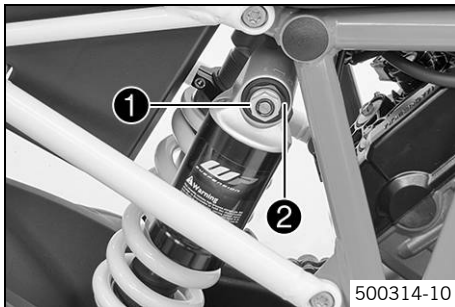

- Turn adjusting screw **1** all the way clockwise with a socket wrench.



Info

Do not loosen fitting **2**!

- Turn counterclockwise by the number of turns corresponding to the shock absorber type.

Guideline

Compression damping, high-speed	
Comfort	1.5 turns
Standard	1.5 turns
Sport	1 turn
Full payload	1 turn



Info

Turn clockwise to increase damping; turn counterclockwise to reduce damping.

12.7 Adjusting the rebound damping of the shock absorber



Caution

Danger of accidents Disassembly of pressurized parts can lead to injury.

- The shock absorber is filled with high density nitrogen. Adhere to the description provided. (Your authorized KTM workshop will be glad to help.)

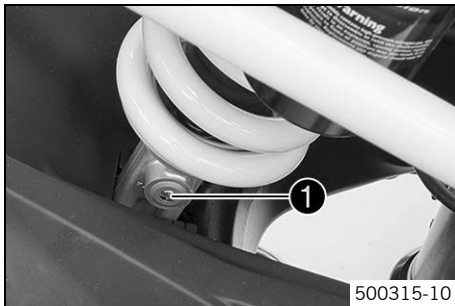

- Turn adjusting screw ① clockwise up to the last perceptible click.
- Turn counterclockwise by the number of clicks corresponding to the shock absorber type.

Guideline

Rebound damping	
Comfort	15 clicks
Standard	12 clicks
Sport	9 clicks
Full payload	9 clicks



Info

Turn clockwise to increase damping; turn counterclockwise to reduce damping.

12.8 Adjusting the spring preload of the shock absorber ↴



Warning

Danger of accidents Modifications to the suspension settings can seriously alter the vehicle's ride behavior.

- Following modifications, ride slowly at first to get the feel of the new ride behavior.

i Info

The spring preload defines the initial situation of the spring process on the shock absorber. The best spring preload setting is achieved when it is set for the weight of the rider and that of any luggage and a passenger, thus ensuring an ideal compromise between maneuverability and stability.

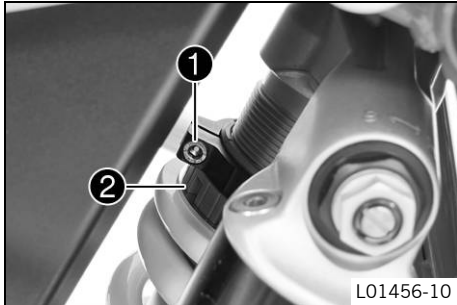

Preparatory work

Condition

- The swingarm is unloaded.

Main work

- Loosen screw ①.
- Turn adjusting ring ② counterclockwise with the hook wrench from the tool set until the spring is no longer under tension.

Hook wrench, shock absorber (61329083000)

12 SUSPENSION SETTING

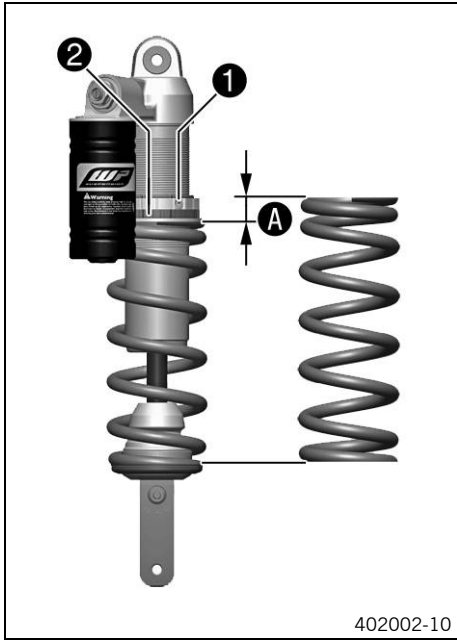

- Tighten the spring by turning adjusting ring ② to the specified measurement ①.

Guideline

Spring preload	
Comfort	5 mm (0.2 in)
Standard	5 mm (0.2 in)
Sport	6 mm (0.24 in)
Full payload	7 mm (0.28 in)

i Info

Turn clockwise to increase the spring preload; turn counterclockwise to reduce the spring preload.

- Tighten screw ①.

Guideline

Screw, shock absorber adjusting ring	M5	5 Nm (3.7 lbf ft)
--------------------------------------	----	-------------------

13.1 Lifting the motorcycle with the rear lifting gear

Note

Danger of damage The parked vehicle may roll away or fall over.

- Always place the vehicle on a firm and even surface.

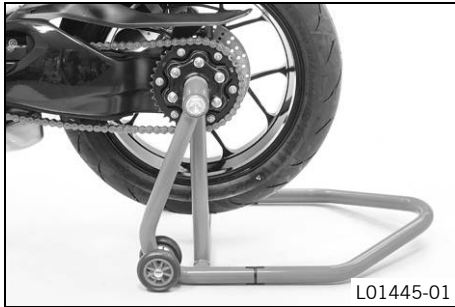

- Place the adapter into the rear lifting gear.

Lifting gear, rear (61329955000)

- Position the motorcycle upright, place the lifting gear in the axle, and raise the motorcycle.

13.2 Removing the rear of motorcycle from the lifting gear

Note

Danger of damage The parked vehicle may roll away or fall over.

- Always place the vehicle on a firm and even surface.

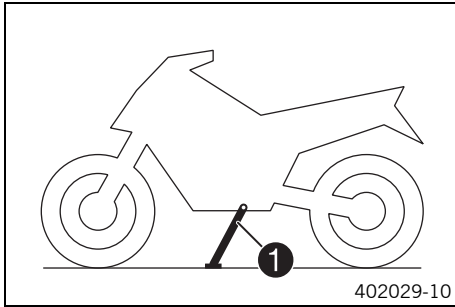

- Secure the motorcycle against falling over.
- Remove the rear wheel stand and lean the vehicle on side stand ①.

13.3 Lifting the motorcycle with the front lifting gear

Note

Danger of damage The parked vehicle may roll away or fall over.

- Always place the vehicle on a firm and even surface.

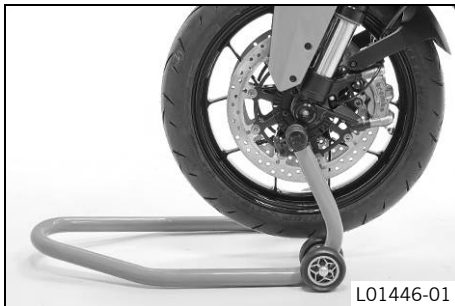

Preparatory work

- Lift the motorcycle with the rear lifting gear. (☛ p. 89)

Main work

- Move the handlebar to the straight-ahead position. Align the front lifting gear with the fork legs.

Front wheel stand (61029055300)

Info

Always raise the motorcycle at the rear first.

- Raise the motorcycle at the front.

13.4 Taking the motorcycle from the front lifting gear

Note

Danger of damage The parked vehicle may roll away or fall over.

- Always place the vehicle on a firm and even surface.



- Secure the motorcycle against falling over.
- Remove the front lifting gear.

13.5 Removing the passenger seat

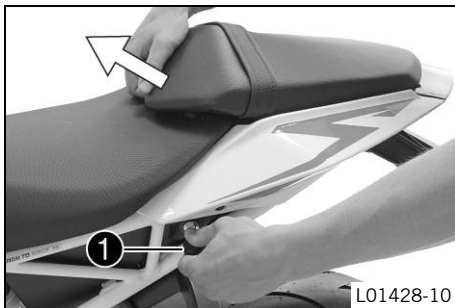

- Insert the ignition key in seat lock ❶ and turn it clockwise.
- Lift the passenger seat at the front and pull it out of the holder toward the front.
- Remove the passenger seat.
- Remove the ignition key.

13.6 Mounting the passenger seat

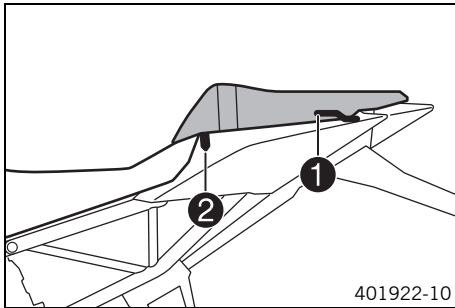

- Attach the recesses of the passenger seat in the guides ❶ and lower at the front while pushing it back.
- Position locking pin ❷ in the lock housing and push down the passenger seat at the front.
 - ✓ The locking pin engages with an audible click.
- Check that the passenger seat is correctly mounted.

13.7 Removing the front rider's seat

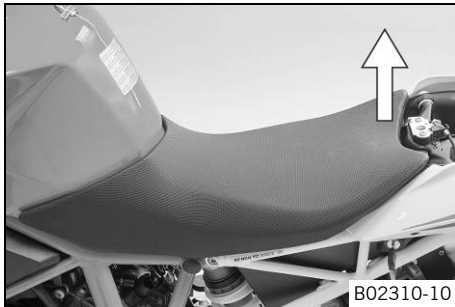

Preparatory work

- Remove the passenger seat. (🔧 p. 91)

Main work

- Raise the rear of the front rider's seat.
- Detach the front of the front rider's seat and remove it.

13.8 Mounting the front rider's seat

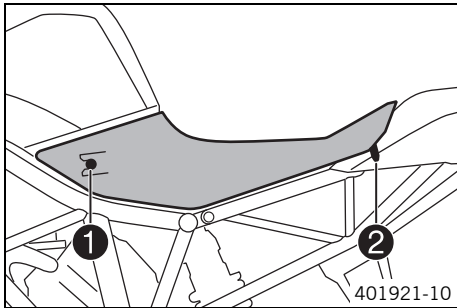

Main work

- Attach recesses ① on the front rider's seat to the fuel tank and push the front rider's seat forward while lowering it.
- ✓ Catch ② is located in the recess.
- Check that the front rider's seat is correctly mounted.

Finishing work

- Mount the passenger seat. (👉 p. 92)

13.9 Mounting the helmet lock on the vehicle



Warning

Danger of accidents Impairment of vehicle handling and vehicle operation if a helmet or helmet lock is attached to the vehicle.

- Do not use the helmet lock for holding a helmet or other objects during the journey. Always remove the helmet lock before starting out.

13 SERVICE WORK ON THE CHASSIS

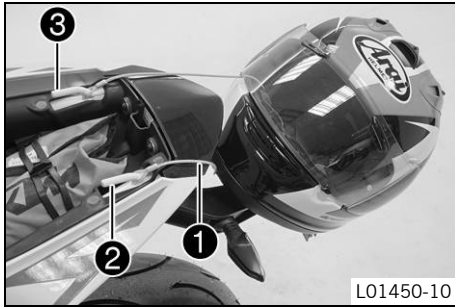

- Remove the passenger seat. (🔧 p. 91)
- Position steel cable ① from the tool set with the loop around catch ②.

Steel cable (60012015000)

- Pass the steel cable through the helmet opening.
- Position the other loop of the steel cable around catch ③.
- Carefully position the helmet on the back of the vehicle.
- Mount the passenger seat. (🔧 p. 92)

13.10 Disassembling the main silencer 🛠️

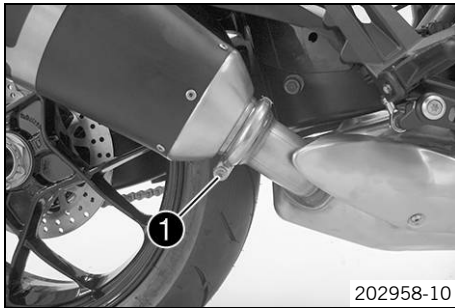

- Remove screw ①.
- Remove the exhaust clamp.

13 SERVICE WORK ON THE CHASSIS

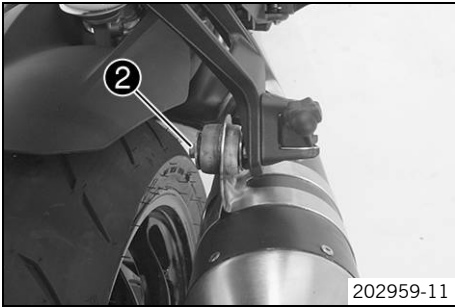

- Remove screw ② with the washer.
- Take off the main silencer.

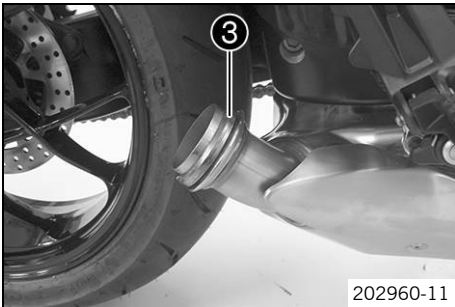

- Remove seal ring ③.

13.11 Installing the main silencer ↗

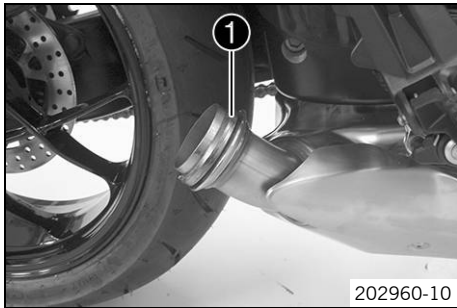

- Mount seal ring ①.

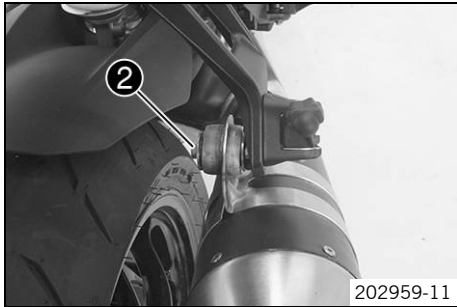

- Position the main silencer.
- Mount screw ② with the washer but do not tighten yet.

Guideline

Remaining screws, chassis	M8	25 Nm (18.4 lbf ft)
---------------------------	----	------------------------

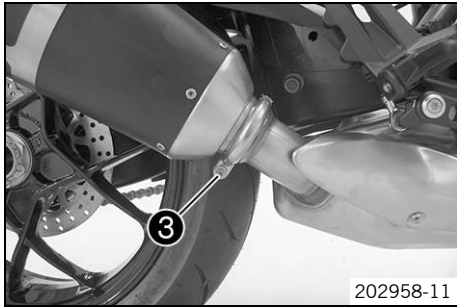

- Position the exhaust clamp.
- Mount and tighten screw ③.

Guideline

Screw, exhaust clamp on main silencer	M6	8 Nm (5.9 lbf ft)
---------------------------------------	----	-------------------

- Tighten screw ②.

Guideline

Remaining screws, chassis	M8	25 Nm (18.4 lbf ft)
---------------------------	----	------------------------

13.12 Checking the chain for dirt

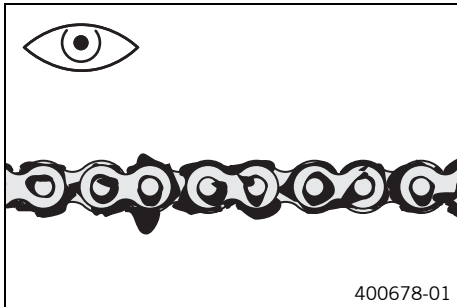

- Check the chain for coarse dirt accumulation.
 - » If the chain is very dirty:
 - Clean the chain. (🔧 p. 97)

13.13 Cleaning the chain



Warning

Danger of accidents Oil or grease on the tires reduces their grip.

- Remove oil and grease with a suitable cleaning material.

13 SERVICE WORK ON THE CHASSIS



Warning

Danger of accidents Reduced braking efficiency due to oil or grease on the brake discs.

- Always keep the brake discs free of oil and grease, and clean them with brake cleaner when necessary.



Warning

Environmental hazard Hazardous substances cause environmental damage.

- Oil, grease, filters, fuel, cleaners, brake fluid, etc., should be disposed of as stipulated in applicable regulations.



Info

The service life of the chain depends largely on its maintenance.

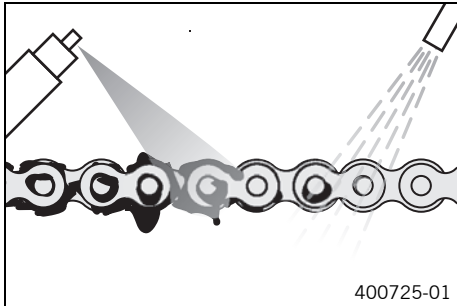

- Clean the chain regularly.
- Rinse off loose dirt with a soft jet of water.
- Remove old grease remains with chain cleaner.

Chain cleaner (☛ p. 188)

- After drying, apply chain spray.

Chain lube for road use (☛ p. 188)

13.14 Checking the chain tension



Warning

Danger of accidents Danger caused by incorrect chain tension.

- If the chain is too taut, the components of the secondary power transmission (chain, engine sprocket, rear sprocket, bearings in the transmission and in the rear wheel) will be under additional load. In addition to premature wear, this can cause the chain or the countershaft of the transmission to break in extreme cases. If the chain is too loose, however, it may fall off the engine sprocket or rear sprocket and block the rear wheel or damage the engine. Ensure that the chain tension is correct and adjust it if necessary.

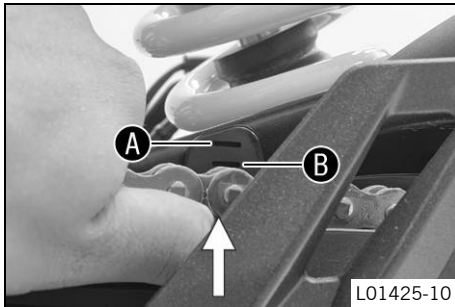

- Place the motorcycle onto the side stand.
- Shift the transmission to idle **N**.
- In the area of markings **A** and **B** on the chain sliding guard, push the chain sliding guard upward and determine the chain tension.



Info

The lower chain section must be taut.

Chain wear is not always even, so you should repeat this measurement at different chain positions.

The upper edge of the chain is located between markings **A** and **B**.

- » If the chain tension does not meet the specification:
 - Adjust the chain tension. (🔧 p. 100)

13.15 Adjusting the chain tension



Warning

Danger of accidents Danger caused by incorrect chain tension.

- If the chain is too taut, the components of the secondary power transmission (chain, engine sprocket, rear sprocket, bearings in the transmission and in the rear wheel) will be under additional load. In addition to premature wear, this can cause the chain or the countershaft of the transmission to break in extreme cases. If the chain is too loose, however, it may fall off the engine sprocket or rear sprocket and block the rear wheel or damage the engine. Ensure that the chain tension is correct and adjust it if necessary.

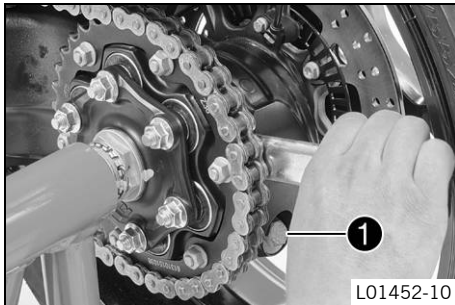

Preparatory work

- Check the chain tension. (☞ p. 99)
- Lift the motorcycle with the rear lifting gear. (☞ p. 89)

Main work

- Loosen screw ❶.
- Set the chain tension by turning the hub housing.

Hook wrench (61329085000)

Handle for ring wrench (60012060000)



Info

Turn clockwise to increase the chain tension; turn counterclockwise to reduce the chain tension.

- Check the chain tension. (☞ p. 99)
- ✓ The chain tension is equal to the specified value.

**Info**

Chain wear is not always even, so you should check the setting at different chain positions.

- Tighten screw ①.

Guideline

Screw, eccentric	M16	70 Nm (51.6 lbf ft)
------------------	-----	------------------------

Finishing work

- Remove the rear of the motorcycle from the lifting gear. (🔧 p. 89)

13.16 Checking the chain, rear sprocket, engine sprocket, and chain guide

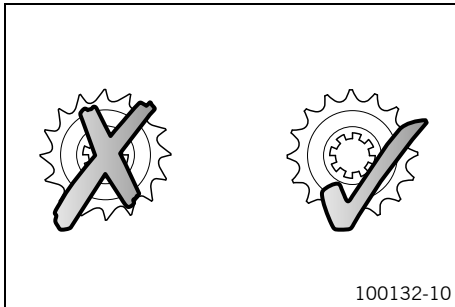

- Check the rear sprocket and engine sprocket for wear.
 - » If the rear sprocket and engine sprocket are worn:
 - Change the drivetrain kit. 🛠️

**Info**

The engine sprocket, rear sprocket, and chain should always be replaced together.

13 SERVICE WORK ON THE CHASSIS

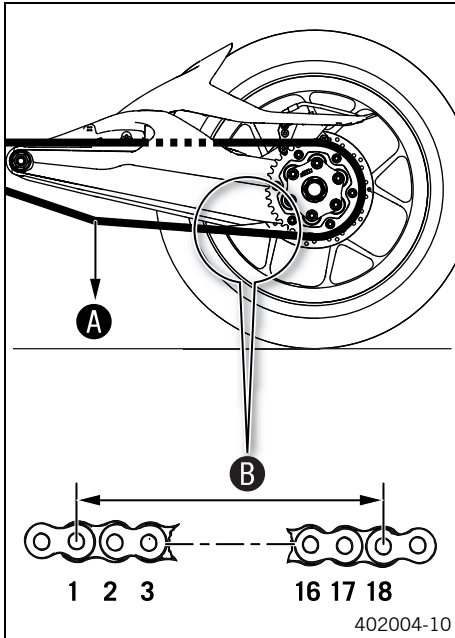

402004-10

- Shift the transmission to idle **N**.
- Pull the lower chain section with specified weight **A**.

Guideline

Weight, chain wear measurement	15 kg (33 lb.)
--------------------------------	----------------

- Measure the distance **B** of 18 chain links in the lower chain section.

i **Info**
Chain wear is not always even, so you should repeat this measurement at different chain positions.

Maximum distance B at the longest chain section	272 mm (10.71 in)
--	-------------------

- » If distance **B** is greater than the specified measurement:
 - Change the drivetrain kit. 

i **Info**
When the chain is replaced, the rear sprocket and engine sprocket should also be changed.
New chains wear out faster on old, worn sprockets.
For safety reasons, the chain has no chain joint.



- Check the chain sliding guard for wear at the cutout.
 - » When rivet **1** of the chain is no longer visible at the bottom edge **C** of the recess of the chain sliding guard:
 - Change the chain sliding guard. 🛠️
- Check that the chain sliding guard is firmly seated.
 - » If the chain sliding guard is loose:
 - Tighten the chain sliding guard.

Guideline

Screw, chain sliding guard	M5	5 Nm (3.7 lbf ft)
----------------------------	----	-------------------

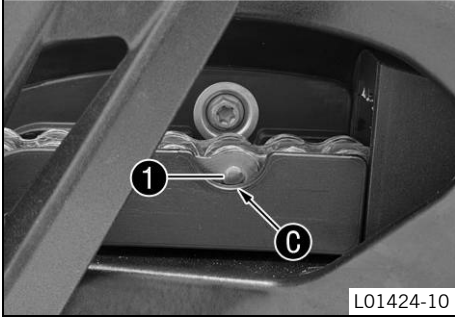

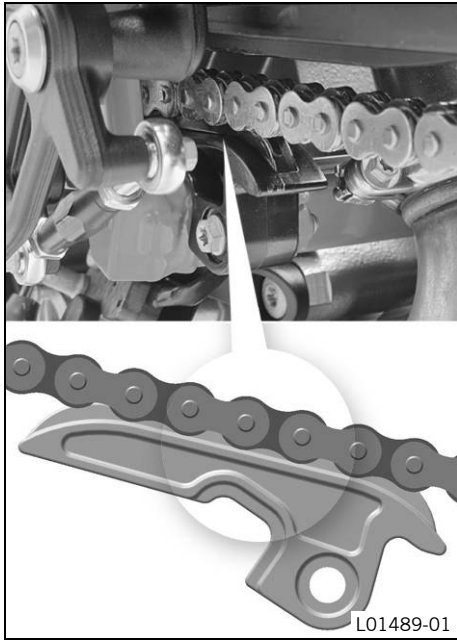

- Check the chain sliding piece for wear.
 - » If the lower edge of the chain pins is in line with or below the chain sliding piece:
 - Change the chain sliding piece. 🛠️
- Check that the chain sliding piece is firmly seated.
 - » If the chain sliding piece is loose:
 - Tighten the chain sliding piece.

Guideline

Remaining screws, chassis	M8	25 Nm (18.4 lbf ft)
---------------------------	----	------------------------

13.17 Checking/correcting the fluid level of the hydraulic clutch

i Info

The fluid level rises with increasing wear of the clutch facing discs.
Do not use brake fluid.

- Move the clutch fluid reservoir mounted on the handlebar to a horizontal position.

13 SERVICE WORK ON THE CHASSIS

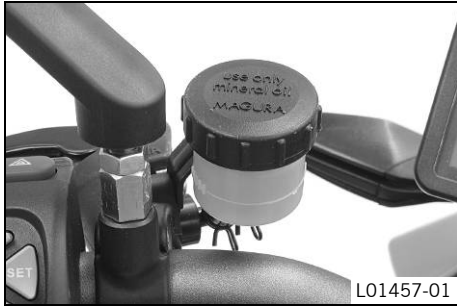

- Check the fluid level.

The fluid level must be between the **MIN** and **MAX** markings.

- » If the coolant level does not meet specifications:
 - Remove the screw cap with the membrane.
 - Correct the fluid level of the hydraulic clutch.

Hydraulic fluid (15) (☛ p. 187)

- Refit the screw cap with the membrane.

14.1 ABS/antilock brake system

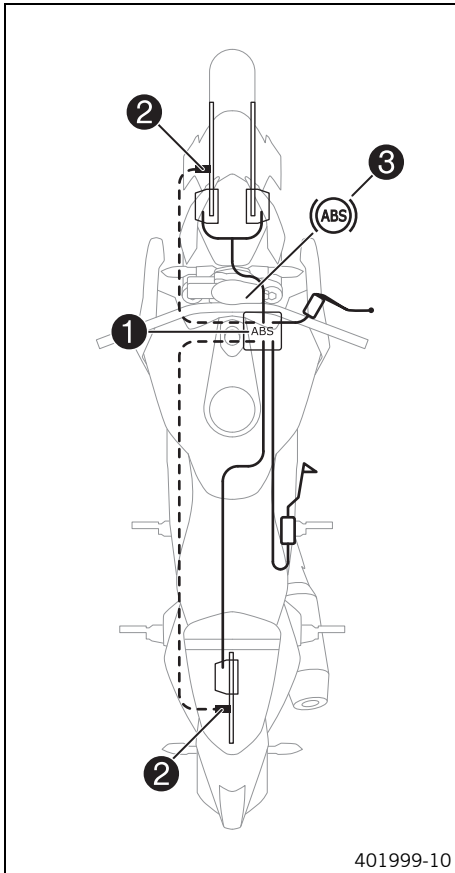

401999-10

The ABS unit **1**, which consists of a hydraulic unit, brake electronics control unit, and return pump, is installed on the right vehicle side below the fuel tank. A wheel speed sensor **2** is located at the front and rear wheels.



Warning

Danger of accidents Functional limitations of the ABS

- The rear wheel may only be spun with the front brake applied (burn out) if the ABS is switched off.
- If the vehicle has been modified, such as shortened or lengthened spring deflections, different rim diameters, different tires, the wrong tire air pressure, different brake linings, etc., the ABS will not function optimally. Optimal functioning of the ABS is only ensured if the brake system only contains spare parts and tires that have been approved and/or recommended by KTM.
- Service work and repairs must be performed properly. (Your authorized KTM workshop will be glad to help.)

The ABS is a safety system that prevents locking of the wheels when driving straight ahead without the influence of lateral forces.



Warning

Danger of accidents Vehicle rollover

- It is not always possible to prevent vehicle rollover in extreme riding situations (e. g. luggage loaded with a high center of gravity, varying road surfaces, steep descents, full braking without disengaging the gear). Adapt your riding style to the road conditions and your riding ability.

ABS has two operating modes: the **"ROAD"** and **"SUP MOT"** ABS modes. In the **"ROAD"** ABS mode, the ABS controls both wheels.

In the **"SUP MOT"** ABS mode, the ABS only controls the front wheel. There is no ABS intervention on the rear wheel. The ABS lamp ③ flashes slowly to remind you that the **"SUP MOT"** ABS mode is enabled.



Info

In the **"SUP MOT"** ABS mode, the rear wheel may block and there is a risk of crashing.

The ABS operates with two independent brake circuits (front and rear brakes). When the brake electronics control unit detects a locking tendency in a wheel, ABS begins regulating the brake pressure. The regulating process causes a slight pulsing of the hand and foot brake levers.

ABS lamp ③ must light up after the ignition is switched on and go out after starting off. If it does not go out after starting off or if it is lit while riding, this indicates a fault in the ABS system. In this case, the ABS is no longer enabled and the wheels may lock during braking. The brake system itself stays functional; only ABS control is not available. The ABS lamp may also light up if the rotating speeds of the front and rear wheels differ greatly under extreme riding conditions, for example when making wheelies or if the rear wheel spins. This causes the ABS to switch off.

To reenale the ABS, the vehicle must be stopped and the ignition switched off. The ABS is reenabled when the vehicle is switched on again. The ABS lamp goes out when you start off.

In the **"MTC/ABS"** menu, ABS can be switched off manually.



Info

After the ignition is switched back on, ABS is enabled again.

14.2 Checking the brake discs



Warning

Danger of accidents Reduced braking efficiency due to worn brake disc(s).

- Change the worn brake disc(s) without delay. (Your authorized KTM workshop will be glad to help.)

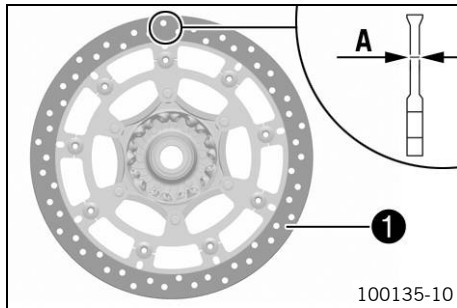

- Check the thickness of the front and rear brake discs at multiple points on each brake disc to ensure it is at least thickness **A**.

i Info

Wear will reduce the thickness of the brake disc at the contact surface **1** of the brake linings.

Brake discs - wear limit

Front	4.5 mm (0.177 in)
Rear	4.5 mm (0.177 in)

- » If the brake disc thickness is less than the specified value.
 - Change the brake disc.
- Check the front and rear brake discs for damage, cracking, and deformation.
 - » If the brake disc exhibits damage, cracking, or deformation:
 - Change the brake disc.

14.3 Checking the brake fluid level of the front brake



Warning

Danger of accidents Failure of the brake system.

- If the brake fluid level falls below the **MIN** mark, this indicates a leakage in the brake system or worn-out brake linings. Check the brake system and do not continue riding. (Your authorized KTM workshop will be glad to help.)



Warning

Danger of accidents Reduced braking efficiency due to old brake fluid.

- Change the brake fluid of the front and rear brake according to the service schedule. (Your authorized KTM workshop will be glad to help.)

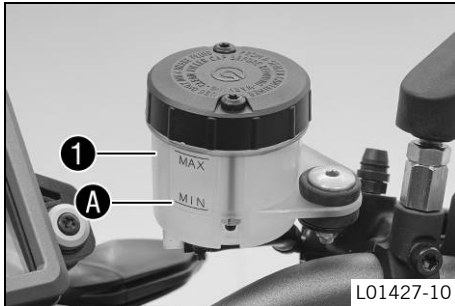

- Move the brake fluid reservoir mounted on the handlebar to a horizontal position.
- Check the brake fluid level in the brake fluid reservoir **1**.
 - » If the brake fluid has dropped below marking **MIN A**:
 - Add front brake fluid. 🛠️ (👉 p. 109)

14.4 Adding front brake fluid 🛠️



Warning

Danger of accidents Failure of the brake system.

- If the brake fluid level falls below the **MIN** mark, this indicates a leakage in the brake system or worn-out brake linings. Check the brake system and do not continue riding. (Your authorized KTM workshop will be glad to help.)



Warning

Skin irritation Brake fluid can cause skin irritation on contact.

- Avoid contact with skin and eyes, and keep out of the reach of children.
- Wear suitable protective clothing and goggles.
- If brake fluid comes into contact with the eyes, flush the eyes thoroughly with water and consult a physician immediately.



Warning

Danger of accidents Reduced braking efficiency due to old brake fluid.

- Change the brake fluid of the front and rear brake according to the service schedule. (Your authorized KTM workshop will be glad to help.)



Warning

Environmental hazard Hazardous substances cause environmental damage.

- Oil, grease, filters, fuel, cleaners, brake fluid, etc., should be disposed of as stipulated in applicable regulations.



Info

Never use DOT 5 brake fluid! It is silicone-based and purple in color. Oil seals and brake lines are not designed for DOT 5 brake fluid.

Avoid contact between brake fluid and painted parts. Brake fluid attacks paint!

Use only clean brake fluid from a sealed container.

Preparatory work

- Check the front brake linings. (👉 p. 111)

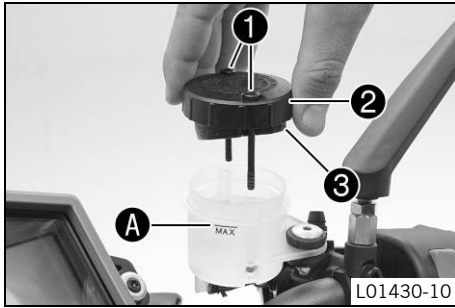

Main work

- Move the brake fluid reservoir mounted on the handlebar to a horizontal position.
- Remove screws ①.
- Remove cover ② with membrane ③.
- Add brake fluid to the **MAX** mark **A**.

Brake fluid DOT 4 / DOT 5.1 (☞ p. 185)

- Position cover ② with membrane ③.
- Mount and tighten screws ①.

Info

Clean up overflowed or split brake fluid immediately with water.

14.5 Checking the front brake linings



Warning

Danger of accidents Reduced braking efficiency caused by worn brake linings.

- Change worn brake linings immediately. (Your authorized KTM workshop will be glad to help.)

Note

Danger of accidents Reduced braking efficiency caused by damaged brake discs.

- If the brake linings are not changed in time, the steel brake lining carriers grind on the brake disc. The braking effect is greatly reduced and the brake discs are destroyed. Check the brake linings regularly.

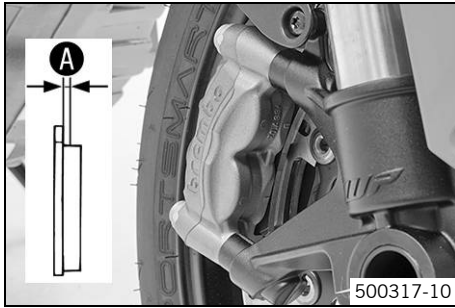

- Check all brake linings on both brake calipers to ensure they have minimum thickness **A**.

Minimum thickness	$\geq 1 \text{ mm } (\geq 0.04 \text{ in})$
-------------------	---

- » If the minimum thickness is less than specified:
 - Change the front brake linings. 🛠️
- Check all brake linings on both brake calipers for damage and cracking.
 - » If there is damage or cracking:
 - Change the front brake linings. 🛠️

14.6 Checking the rear brake fluid level



Warning

Danger of accidents Failure of the brake system.

- If the brake fluid level falls below the **MIN** mark, this indicates a leakage in the brake system or worn-out brake linings. Check the brake system and do not continue riding. (Your authorized KTM workshop will be glad to help.)



Warning

Danger of accidents Reduced braking efficiency due to old brake fluid.

- Change the brake fluid of the front and rear brake according to the service schedule. (Your authorized KTM workshop will be glad to help.)

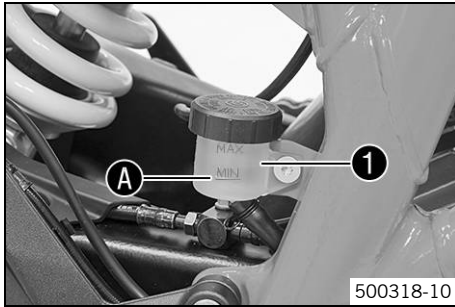

- Stand the vehicle upright.
- Check the brake fluid level in the brake fluid reservoir ①.
 - » If the fluid level reaches the **MIN** marking ②:
 - Add rear brake fluid. 🛠️ (👉 p. 113)

14.7 Adding rear brake fluid 🛠️



Warning

Danger of accidents Failure of the brake system.

- If the brake fluid level falls below the **MIN** mark, this indicates a leakage in the brake system or worn-out brake linings. Check the brake system and do not continue riding. (Your authorized KTM workshop will be glad to help.)



Warning

Skin irritation Brake fluid can cause skin irritation on contact.

- Avoid contact with skin and eyes, and keep out of the reach of children.
- Wear suitable protective clothing and goggles.
- If brake fluid comes into contact with the eyes, flush the eyes thoroughly with water and consult a physician immediately.



Warning

Danger of accidents Reduced braking efficiency due to old brake fluid.

- Change the brake fluid of the front and rear brake according to the service schedule. (Your authorized KTM workshop will be glad to help.)



Warning

Environmental hazard Hazardous substances cause environmental damage.

- Oil, grease, filters, fuel, cleaners, brake fluid, etc., should be disposed of as stipulated in applicable regulations.



Info

Never use DOT 5 brake fluid! It is silicone-based and purple in color. Oil seals and brake lines are not designed for DOT 5 brake fluid.

Avoid contact between brake fluid and painted parts. Brake fluid attacks paint!

Use only clean brake fluid from a sealed container.

Preparatory work

- Check the brake linings of the rear brake. (☞ p. 115)

Main work

- Stand the vehicle upright.
- Remove screw cap ❶ with membrane ❷.
- Add brake fluid to the **MAX** mark **A**.

Brake fluid DOT 4 / DOT 5.1 (☞ p. 185)

- Mount and tighten screw cap ❶ with membrane ❷.



Info

Clean up overflowed or split brake fluid immediately with water.

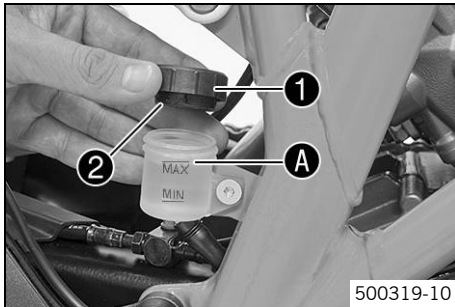

14.8 Checking the brake linings of the rear brake



Warning

Danger of accidents Reduced braking efficiency caused by worn brake linings.

- Change worn brake linings immediately. (Your authorized KTM workshop will be glad to help.)

Note

Danger of accidents Reduced braking efficiency caused by damaged brake discs.

- If the brake linings are not changed in time, the steel brake lining carriers grind on the brake disc. The braking effect is greatly reduced and the brake discs are destroyed. Check the brake linings regularly.

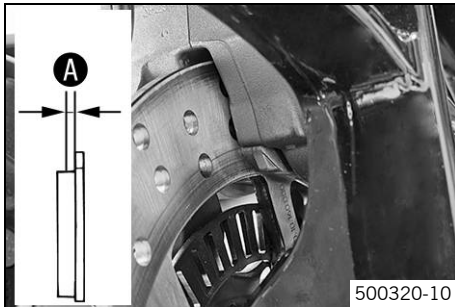

- Check the brake linings for minimum thickness **A**.

Minimum thickness A	$\geq 1 \text{ mm } (\geq 0.04 \text{ in})$
----------------------------	---

- » If the minimum thickness is less than specified:
 - Change the rear brake linings. 🛠️
- Check the brake linings for damage and cracking.
 - » If there is damage or cracking:
 - Change the rear brake linings. 🛠️

15.1 Removing the front wheel ↘

Preparatory work

- Lift the motorcycle with the rear lifting gear. (👉 p. 89)
- Lift the motorcycle with the front lifting gear. (👉 p. 90)

Main work

- Remove screws ① from both brake calipers.
- Press back the brake linings with a light lateral tilting of the brake calipers on the brake disc. Pull the brake calipers carefully back from the brake discs and hang them to one side.

Info

Do not pull the hand brake lever when the brake caliper has been removed.

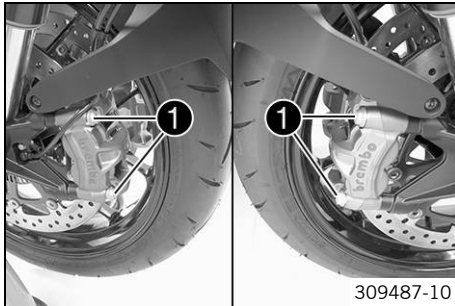

- Loosen screws ② and ③.
- Unscrew screw ② about six turns and press your hand on the screw to push the wheel spindle out of the axle clamp. Remove screw ②.

Warning

Danger of accidents Reduced braking efficiency due to damaged brake discs.

- Always lay down the wheel in such a way that the brake discs are not damaged.
-
- Holding the front wheel, withdraw the wheel spindle. Take the front wheel out of the fork.

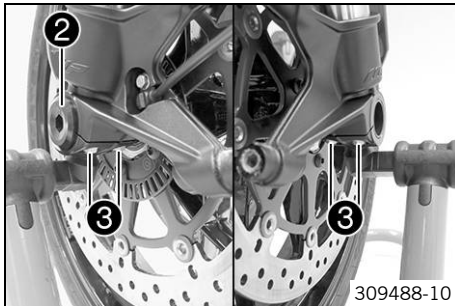

15 WHEELS, TIRES

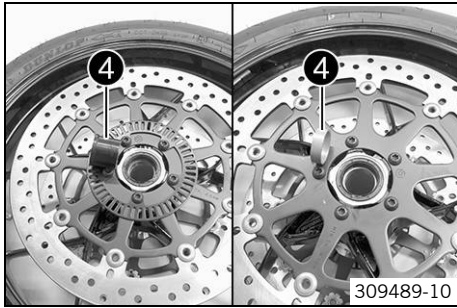

- Remove spacers 4.

15.2 Installing the front wheel ↗

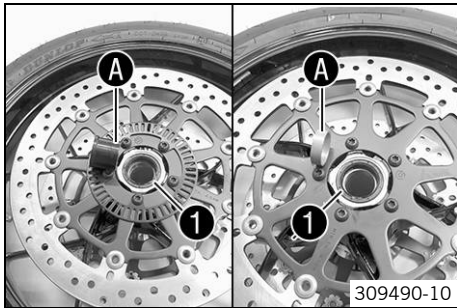

- Check the wheel bearing for damage and wear.
 - » If the wheel bearing is damaged or worn:
 - Change the front wheel bearing. ↗
- Clean and grease the shaft seal rings 1 and mating surfaces A of the spacers.

Long-life grease (↗ p. 188)

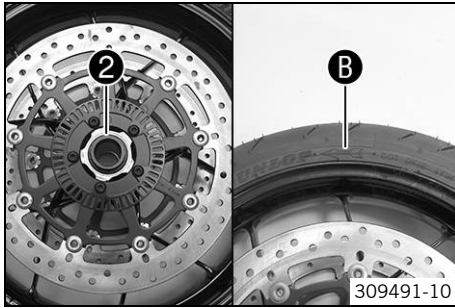

- Insert the wide spacer **2** on the left in the direction of travel.



Info

The arrow **B** indicates the direction of travel of the front wheel.

- Insert the narrow spacer on the right in the direction of travel.



Warning

Danger of accidents Reduced braking efficiency due to oil or grease on the brake discs.

- Always keep the brake discs free of oil and grease, and clean them with brake cleaner when necessary.

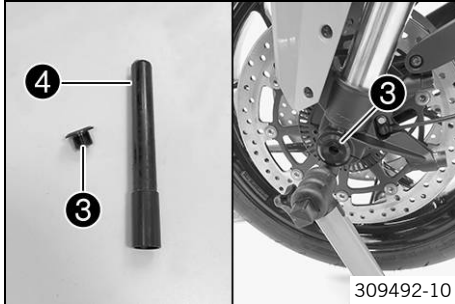

- Clean screw **3** and wheel spindle **4**.
- Lift the front wheel into the fork, position it, and insert the wheel spindle.
- Mount and tighten screw **3**.

Guideline

Bolt, front axle	M25x1.5	45 Nm (33.2 lbf ft)	Thread greased
------------------	---------	------------------------	----------------

15 WHEELS, TIRES

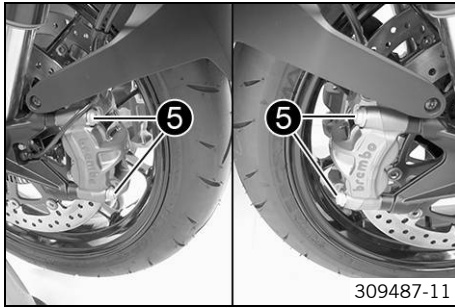

- Position the brake calipers and check that the brake linings are seated correctly.
- Mount screws **5** on both brake calipers but do not tighten yet.
- Operate the hand brake lever repeatedly until the brake linings are in contact with the brake disc and there is a pressure point. Fix the hand brake lever in the activated position.
 - ✓ The brake calipers straighten.
- Tighten screws **5** on both brake calipers.

Guideline

Screw, front brake caliper	M10	45 Nm (33.2 lbf ft)	Loctite® 243™
----------------------------	-----	------------------------	----------------------

- Remove the fixation of the hand brake lever.
- Take the motorcycle from the front lifting gear. (☛ p. 91)
- Remove the rear of the motorcycle from the lifting gear. (☛ p. 89)
- Pull the front brake and compress the fork forcefully a few times.
 - ✓ The fork legs straighten.
- Tighten screws **6**.

Guideline

Screw, axle clamp	M8	15 Nm (11.1 lbf ft)	
-------------------	----	------------------------	--

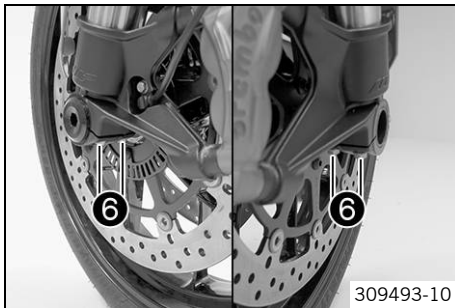

15.3 Removing the rear wheel 🛠️

Preparatory work

- Lift the motorcycle with the rear lifting gear. (👉 p. 89)
- Disassemble the main silencer. 🛠️ (👉 p. 94)

Main work

- Remove the inside locking wire ❶.
- Remove the outside locking wire ❷.

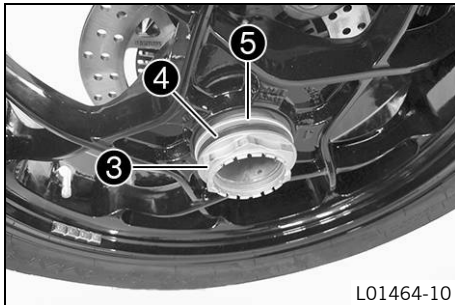
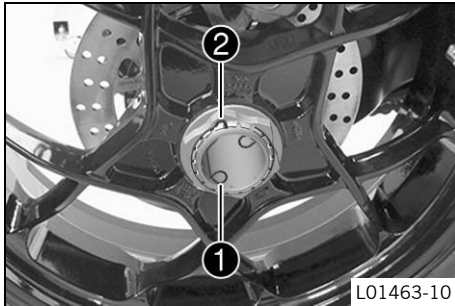

- Have an assistant operate the rear brake.
- Release nut ❸ and remove with washer ❹ and taper ring ❺.



- Take off the rear wheel.

15.4 Installing the rear wheel 🛠️



Warning

Danger of accidents Reduced braking efficiency due to oil or grease on the brake discs.

- Always keep the brake discs free of oil and grease, and clean them with brake cleaner when necessary.



Warning

Danger of accidents No braking effect when operating the rear brake.

- After installing the rear wheel, always operate the foot brake until the pressure point is reached.

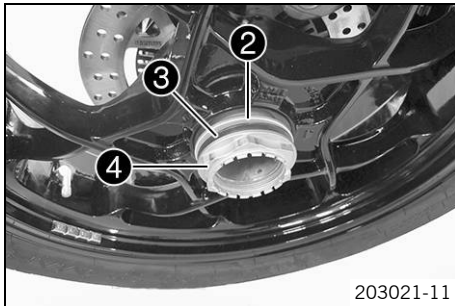
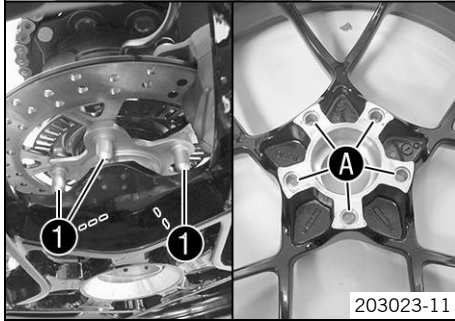

Main work

- Check the rear wheel bearing for damage and wear.
 - » If the rear wheel bearing is damaged or worn:
 - Change the rear wheel bearing. 🛠️
- Clean and grease the threads of the wheel axle and axle nut.

Long-life grease (👉 p. 188)

- Slide the rear wheel onto the axle.
 - ✓ Driving pins ❶ engage in drilled holes ❷ of the rim.

- Mount taper ring ❷, washer ❸ and nut ❹.
- Have an assistant operate the rear brake.
- Tighten nut ❹.

Guideline

Nut, rear axle	M50x1.5	250 Nm (184.4 lbf ft)	Lock the locking wire with locking varnish
----------------	---------	--------------------------	--

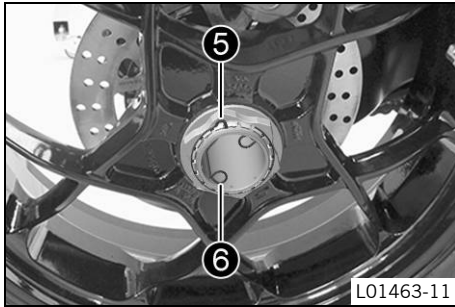

- Mount the outside locking wire 5.
- Mount the inside locking wire 6.
- ✓ The pins of the locking wires engage in the drilled holes of the wheel axle.

Finishing work

- Remove the rear of the motorcycle from the lifting gear. (☞ p. 89)
- Install the main silencer. 🛠️ (☞ p. 96)

15.5 Checking the tire condition



Warning

Danger of accidents Uncontrollable vehicle handling in the event of a flat tire.

- In the interest of safety, replace damaged or worn tires immediately. (Your authorized KTM workshop will be glad to help.)



Warning

Danger of crashing Poor vehicle handling due to different tire tread patterns on front and rear wheels.

- The front and rear wheels must be fitted with tires with similar tread patterns to prevent loss of control over the vehicle.



Warning

Danger of accidents Uncontrollable handling characteristic due to non-approved and/or non-recommended tires/wheels.

- Only tires/wheels approved by KTM and with the corresponding speed index should be used.



Warning

Danger of accidents Reduced road grip with new tires.

- New tires have a smooth rolling surface and therefore cannot provide full road grip. The entire rolling surface must be roughened in the first 200 kilometers (124.3 miles) by moderate riding at alternating angles. The full grip levels are not achieved until the tires have been run in.



Info

Tire type, tire condition, and tire air pressure influence the braking and handling characteristics of the vehicle. Worn tires are particularly unfavorable on wet surfaces.

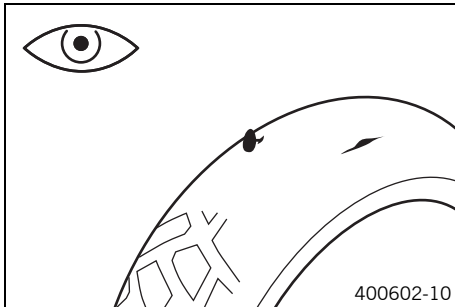

- Check the front and rear tires for cuts, run-in objects, and other damage.
 - » If the tires have cuts, run-in objects or other damage:
 - Change the tires.
- Check the depth of the tread.



Info

Adhere to the legally required minimum tread depth.

Minimum tread depth	$\geq 2 \text{ mm } (\geq 0.08 \text{ in})$
---------------------	---

- » If the tread depth is less than the minimum tread depth:
 - Change the tires.
- Check the tire age.



Info

The tire date of manufacture is usually contained in the tire label and is indicated by the last four digits of the **DOT** number. The first two digits indicate the week of manufacture and the last two digits the year of manufacture. KTM recommends that the tires be changed after 5 years at the latest, regardless of the actual state of wear.

- » If the tire is more than 5 years old:
 - Change the tires.

15.6 Checking the tire air pressure



Info

Low tire air pressure leads to abnormal wear and overheating of the tire. Correct tire air pressure ensures optimal riding comfort and maximum tire service life.

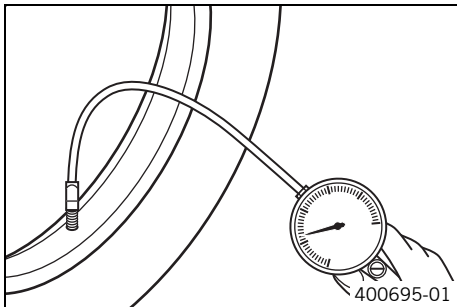

- Remove the dust cap.
- Check the tire air pressure when the tires are cold.

Tire air pressure, solo/with passenger/full payload	
Front: with cold tires	2.5 bar (36 psi)
Rear: with cold tires	2.9 bar (42 psi)

- » If the tire pressure does not meet specifications:
 - Correct the tire pressure.
- Mount the dust cap.

16.1 Daytime running light



The daytime running light/parking light is integrated in the main headlight. The daytime running light can be switched on when visibility conditions are good. Activate the daytime running light in the combination instrument. Control is provided by the brightness sensor in the combination instrument. When visibility conditions are good, the low beam is switched off and the daytime running light is switched on. It is four times brighter than the parking light. When the daytime running light is switched off, it serves as a parking light.



Info

Note the legal regulations regarding the daytime running light.

16.2 Removing the battery



Warning

Risk of injury Battery acid and battery gases cause serious chemical burns.

- Keep batteries out of the reach of children.
- Wear suitable protective clothing and goggles.
- Avoid contact with battery acid and battery gases.
- Keep sparks and open flames away from the battery. Only charge in well-ventilated rooms.
- In the event of skin contact, rinse with large amounts of water. If battery acid gets in the eyes, rinse with water for at least 15 minutes and contact a physician.



Caution

Danger of accidents If the vehicle is operated with a discharged battery or without a battery, electronic components and safety equipment may be damaged.

- Never operate the vehicle with a discharged battery or without a battery.

Preparatory work

- Switch off all power consumers and switch off the engine.
- Remove the passenger seat. (☛ p. 91)
- Remove the front rider's seat. (☛ p. 92)

Main work

- Remove screw ①.
- Lift cover ② at the rear and pull toward the rear.
- Fold up the cover.

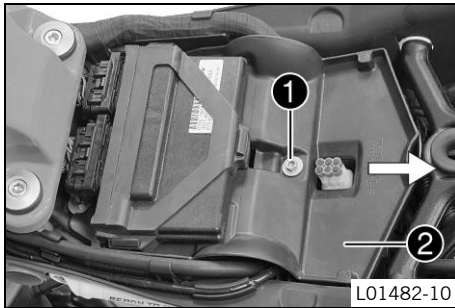

- Disconnect negative cable ③ of the battery.
- Remove positive terminal cover ④ and disconnect the positive cable from the battery.
- Take the battery ⑤ out of the battery compartment.

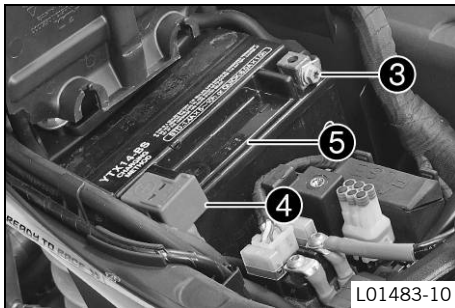

16.3 Installing the battery ↱



Warning

Risk of injury Battery acid and battery gases cause serious chemical burns.

- Keep batteries out of the reach of children.
- Wear suitable protective clothing and goggles.
- Avoid contact with battery acid and battery gases.
- Keep sparks and open flames away from the battery. Only charge in well-ventilated rooms.
- In the event of skin contact, rinse with large amounts of water. If battery acid gets in the eyes, rinse with water for at least 15 minutes and contact a physician.



Caution

Danger of accidents If the vehicle is operated with a discharged battery or without a battery, electronic components and safety equipment may be damaged.

- Never operate the vehicle with a discharged battery or without a battery.

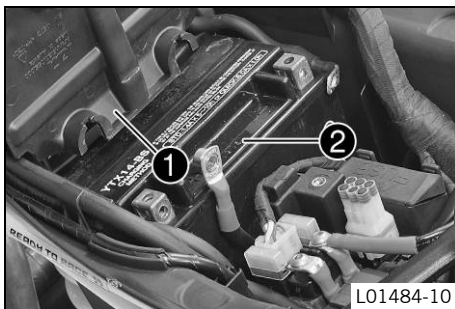

Main work

- Fold up cover ①.
- Place battery ② in the battery compartment.

16 ELECTRICAL SYSTEM

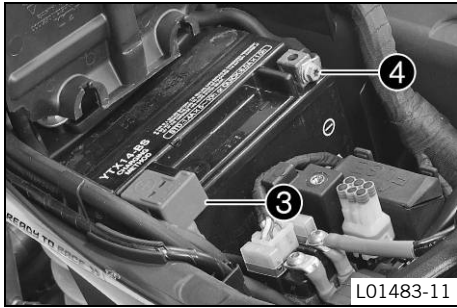

- Position the positive cable and mount and tighten the screw.

Guideline

Screw, battery terminal	M6	4.5 Nm (3.32 lbf ft)
-------------------------	----	-------------------------

- Mount positive terminal cover **3**.
- Position negative cable **4** and mount and tighten the screw.

Guideline

Screw, battery terminal	M6	4.5 Nm (3.32 lbf ft)
-------------------------	----	-------------------------

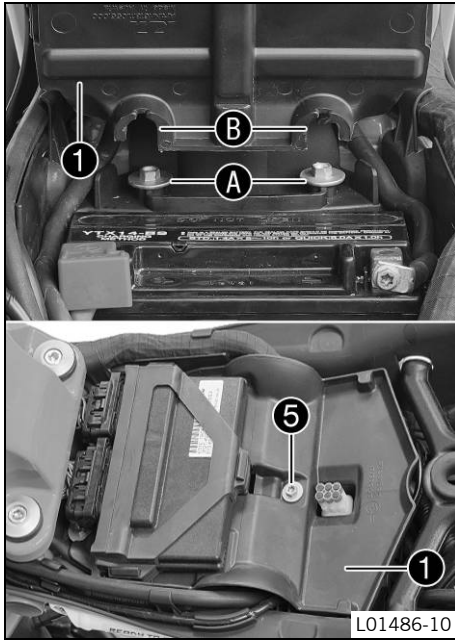

- Position cover ①.
- ✓ Screw heads ① engage in recesses ②.
- Mount and tighten screw ③.

Finishing work

- Mount the front rider's seat. (☛ p. 93)
- Mount the passenger seat. (☛ p. 92)
- Set the time and date.

16.4 Recharging the battery ↴



Warning

Risk of injury Battery acid and battery gases cause serious chemical burns.

- Keep batteries out of the reach of children.
- Wear suitable protective clothing and goggles.
- Avoid contact with battery acid and battery gases.
- Keep sparks and open flames away from the battery. Only charge in well-ventilated rooms.
- In the event of skin contact, rinse with large amounts of water. If battery acid gets in the eyes, rinse with water for at least 15 minutes and contact a physician.



Warning

Environmental hazard The battery contains elements that are harmful to the environment.

- Do not dispose of batteries with the household waste. Dispose of a defective battery in an environmentally friendly manner. Give the battery to your authorized KTM dealer or dispose of it at a collection point for used batteries.



Warning

Environmental hazard Hazardous substances cause environmental damage.

- Oil, grease, filters, fuel, cleaners, brake fluid, etc., should be disposed of as stipulated in applicable regulations.
-

i Info

Even when there is no load on the battery, it discharges steadily.

The charge state and the type of charge are very important for the service life of the battery.

Rapid recharging with a high charging current shortens the battery's service life.

If the charging current, charging voltage, and charging time are exceeded, electrolyte escapes through the safety valves. This reduces the battery capacity.

If the battery is depleted from starting the vehicle repeatedly, the battery must be charged immediately.

If the battery is left in a discharged state for an extended period, it will become over-discharged and sulfate, destroying the battery.

The battery is maintenance-free, i.e., the acid level does not have to be checked.

If the battery is not charged using the KTM battery charger, the battery must be removed for charging. Otherwise, overvoltage may damage electronic components. Charge the battery according to the instructions on the battery housing.

Preparatory work

- Switch off all power consumers and switch off the engine.
- Remove the passenger seat. (☛ p. 91)
- Remove the front rider's seat. (☛ p. 92)

Main work

- Remove screw ①.
- Lift cover ② at the rear and pull toward the rear.
- Fold up the cover.

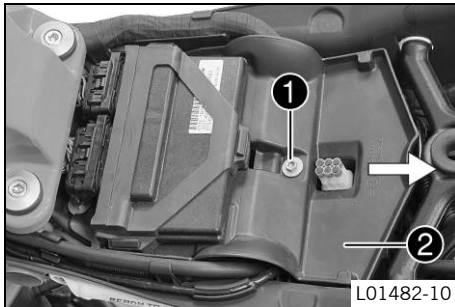

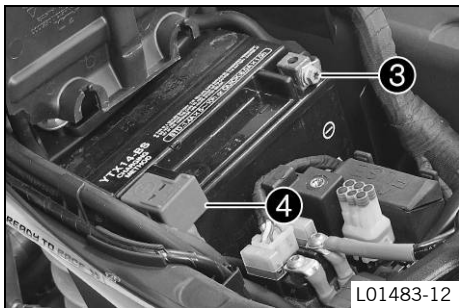

- Disconnect negative cable ③ of the battery to avoid damage to the motorcycle's electronics.
- Remove positive terminal cover ④.



- Connect the battery charger to the battery. Switch on the battery charger.

Battery charger (58429074000)

You can also use the battery charger to test the open-circuit voltage and start potential of the battery, and to test the alternator. With this device, you cannot overcharge the battery.

i Info Charge the battery with a maximum of 10% of the capacity specified on the battery housing.

- Switch off and disconnect the battery charger from the battery after charging.

Guideline

The charging current, charging voltage, and charging time must not be exceeded.	
Charge the battery regularly when the motorcycle is not in use	3 months

16 ELECTRICAL SYSTEM

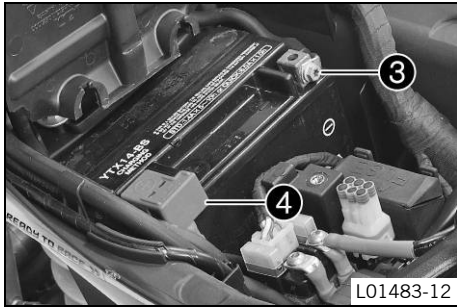

- Mount positive terminal cover 4.
- Position negative cable 3 and mount and tighten the screw.

Guideline

Screw, battery terminal	M6	4.5 Nm (3.32 lbf ft)
-------------------------	----	-------------------------

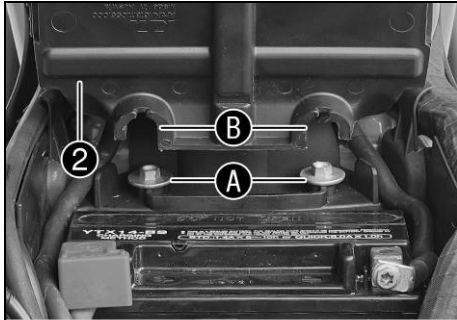

- Position cover 2.
- ✓ Screw heads A engage in recesses B.
- Mount and tighten screw 1.

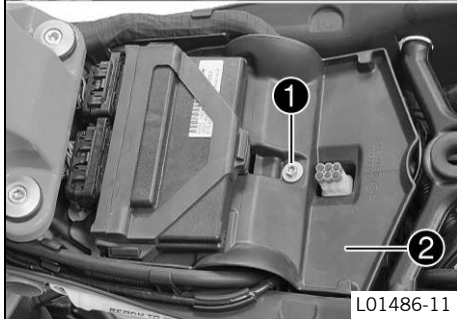

Finishing work

- Mount the front rider's seat. (☛ p. 93)
- Mount the passenger seat. (☛ p. 92)
- Set the time and date.

16.5 Changing the main fuse



Warning

Fire hazard The electrical system can be overloaded if the wrong fuses are used.

- Use only fuses with the prescribed amperage. Never bypass or repair fuses.

Preparatory work

- Switch off all power consumers and switch off the engine.
- Remove the passenger seat. (☛ p. 91)
- Remove the front rider's seat. (☛ p. 92)

Main work

- Remove screw ①.
- Lift cover ② at the rear and pull toward the rear.
- Fold up the cover.

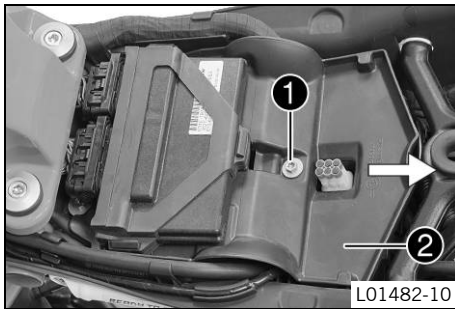

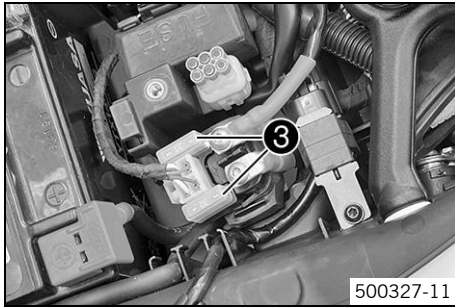

- Remove protection caps **3**.

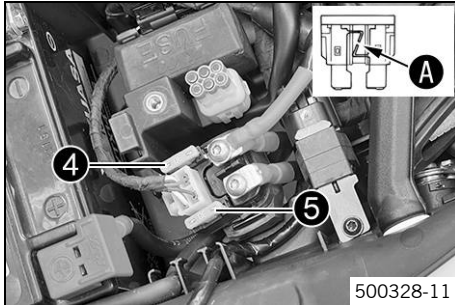

- Remove the faulty main fuse **4**.

i **Info**

A defective fuse is indicated by a burned-out fuse wire **A**.
A spare fuse **5** is located in the starter relay.
The main fuse protects all power consumers of the vehicle.

- Install a new main fuse.

Fuse (58011109130) (👉 p. 177)

- Check that the electrical equipment is functioning properly.
- Mount the protection caps.

i **Tip**

Insert a new spare fuse into the starter relay to have it available when needed.

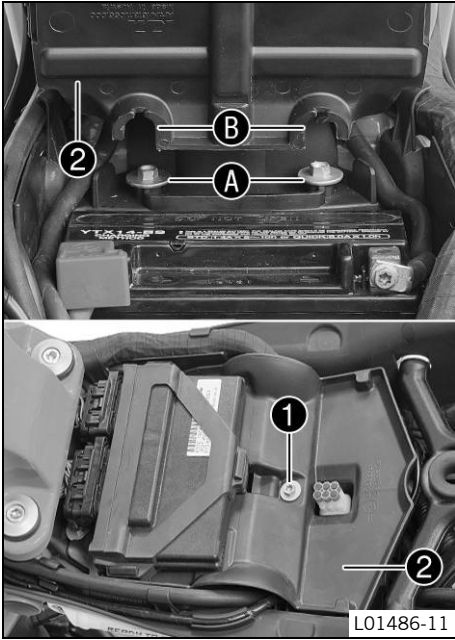

- Position cover ②.
- ✓ Screw heads ① engage in recesses ②.
- Mount and tighten screw ①.

Finishing work

- Mount the front rider's seat. (☛ p. 93)
- Mount the passenger seat. (☛ p. 92)
- Set the time and date.

16.6 Changing the fuses in the fuse box



Warning

Fire hazard The electrical system can be overloaded if the wrong fuses are used.

- Use only fuses with the prescribed amperage. Never bypass or repair fuses.



Info

The fuse box containing the fuses of individual power consumers is located under the seat.

Preparatory work

- Switch off all power consumers and switch off the engine.
- Remove the passenger seat. (☛ p. 91)
- Remove the front rider's seat. (☛ p. 92)

Main work

- Remove screw ①.
- Lift cover ② at the rear and pull toward the rear.
- Fold up the cover.

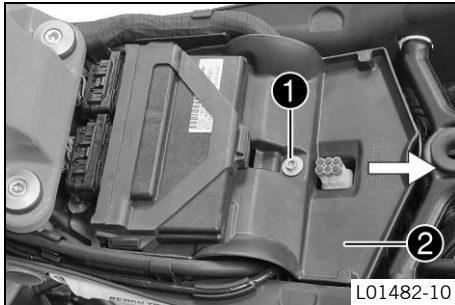

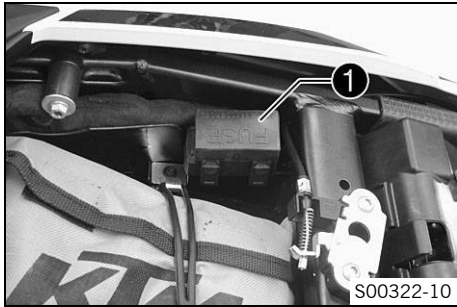

- Open fuse box cover **1**.

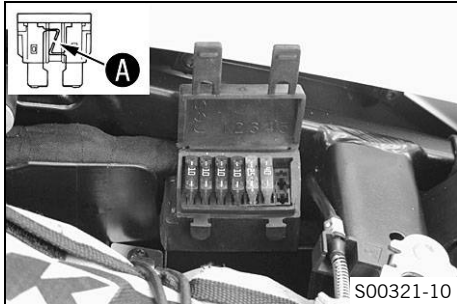

- Check the fuses.

i Info

A defective fuse is indicated by a burned-out fuse wire **A**.

- Remove the defective fuse.

Guideline

Fuse res - 10 A - spare fuses
Fuse 1 - 10 A - power supply for control units and components
Fuse 2 - 10 A - permanent positive for auxiliary equipment (ACC1)
Fuse 3 - 15 A - ABS hydraulic unit
Fuse 4 - 25 A - ABS return pump
Fuse 5 - not used
Fuse res - 15 A - spare fuse
Fuse res - 25 A - spare fuse

- Use spare fuses with the correct rating only.

Fuse (58011109110) (📖 p. 176)

Fuse (58011109115) (☛ p. 176)

Fuse (58011109125) (☛ p. 177)



Tip

Insert a spare fuse so that it is available if needed.

- Check that the power consumer is functioning properly.
- Close the fuse box cover.
- Position cover **2**.
- ✓ Screw heads **A** engage in recesses **B**.
- Mount and tighten screw **1**.

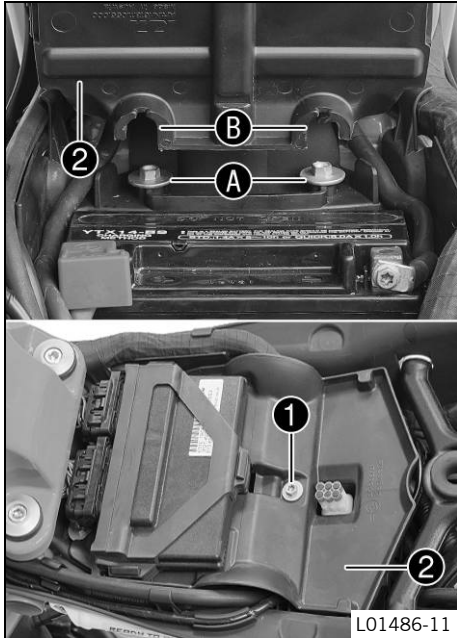

Finishing work

- Mount the front rider's seat. (👉 p. 93)
- Mount the passenger seat. (👉 p. 92)

16.7 Changing the headlight bulb

Note

Damage to reflector Reduced brightness.

- Grease on the lamp will evaporate due to the heat and be deposited on the reflector. Clean the lamp and keep it free of grease before mounting.

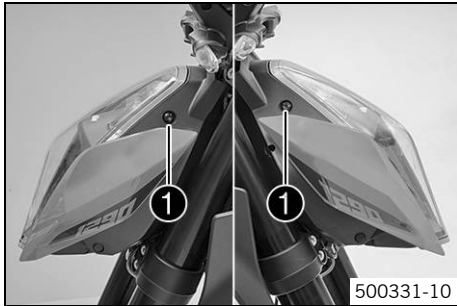

- Remove screws ❶.
- Fold the headlight mask forward.

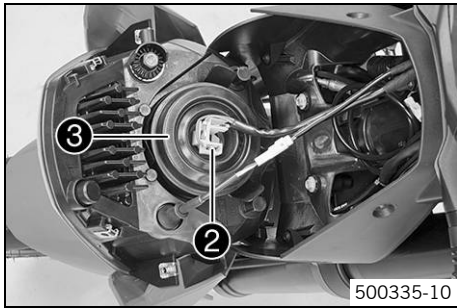

- Detach connector ②.
- Take off rubber cap ③.

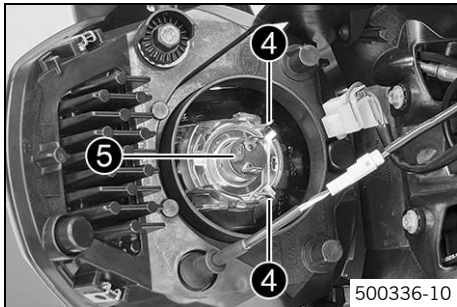

- Detach retaining clamp ④.
- Remove bulb ⑤.
- Position the new bulb in the headlight housing.

Low beam/high beam (H4/socket U37R) (☛ p. 177)



Info

Insert the headlight bulb so that the catches latch into the recesses.

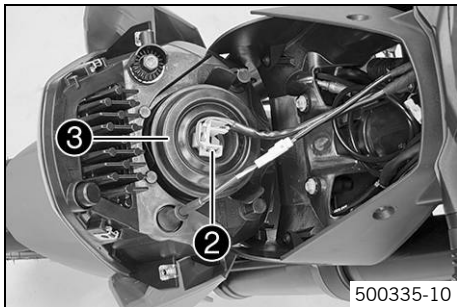

- Attach retaining clamp ④.
- Mount rubber cap ③.
- Plug in connector ②.

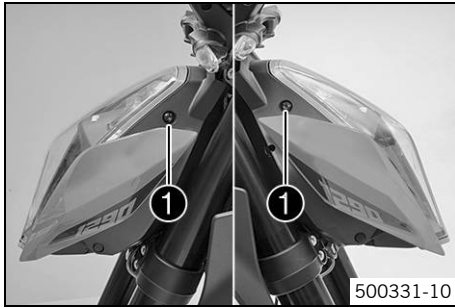

500331-10

- Fold the headlight mask up.
- Mount and tighten screws **1**.

Guideline

Remaining screws, chassis	M5	5 Nm (3.7 lbf ft)
---------------------------	----	-------------------

16.8 Checking the headlight setting

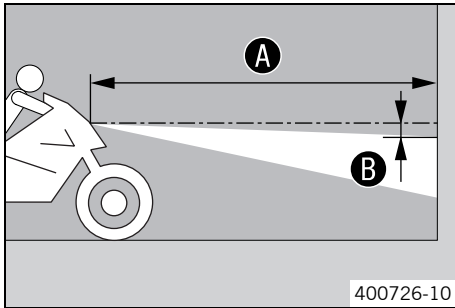

400726-10

- Park the vehicle on a horizontal surface in front of a light-colored wall and make a mark at the height of the center of the low beam headlight.
- Make another mark at a distance **B** under the first mark.

Guideline

Distance B	5 cm (2 in)
-------------------	-------------

- Position the vehicle perpendicular to the wall at a distance **A** from the wall and switch on the low beam.

Guideline

Distance A	5 m (16 ft)
-------------------	-------------

- The rider, with luggage and passenger if applicable, now mounts the motorcycle.
- Check the headlight setting.

The light-dark boundary must lie exactly on the lower mark when the motorcycle is ready to operate with the rider mounted along with any luggage and a passenger if applicable.

- » If the boundary between light and dark does not meet specifications:
 - Adjust the headlight range. (☛ p. 144)

16.9 Adjusting the headlight range

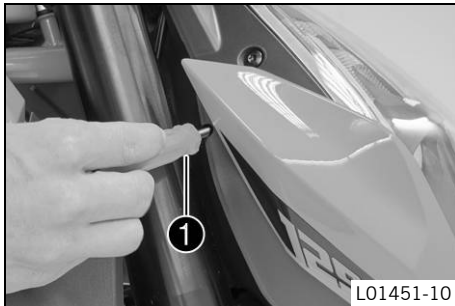

Preparatory work

- Check the headlight setting. (☛ p. 143)

Main work

- Using the cross-head screwdriver **1** from the tool set, adjust the headlight range of the headlight.

Cross-head screwdriver (53012024100)

i Info

Turn clockwise to increase the headlight range; turn counterclockwise to reduce the headlight range.

If you have a payload, you may have to correct the headlight range.

- Set the headlight to marking **B**.

Guideline

The light-dark boundary must lie exactly on the lower mark **B** when the motorcycle is ready to operate with the rider mounted along with any luggage and a passenger if applicable.

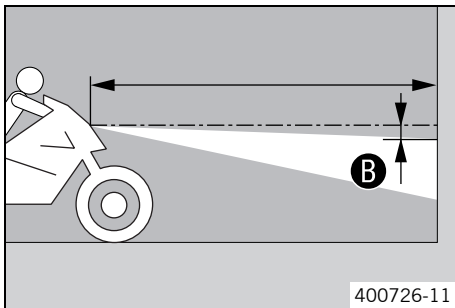

16.10 Activating/deactivating the ignition key

i Info

The orange programming key must only be used for activating and deactivating!

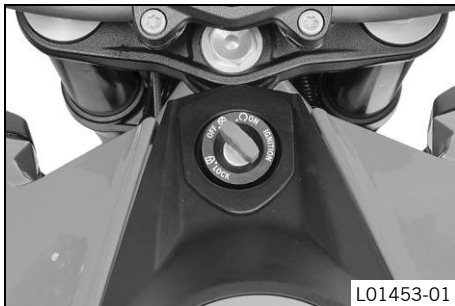
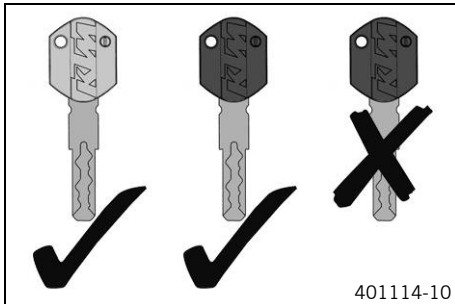

If a black ignition key is lost or needs to be replaced, the individual black ignition keys need to be enabled or disabled using the orange programming key. This prevents the vehicle from being operated with the lost black ignition key.

You can activate or deactivate up to four black ignition keys. Only the black ignition keys programmed during an activation procedure are valid. All black ignition keys not programmed during the activation procedure are invalid, but can be reprogrammed in a further activation procedure.



Loss of a black ignition key (additional black ignition keys are available):

The following procedure deactivates all activated black ignition keys that are not included in the procedure.

- Press the emergency OFF switch to the position **ON** ○.
- Insert the orange programming key in the ignition lock.
- Switch on the ignition by turning the orange programming key to the position **ON** ○.
 - ✓ Immobilizer indicator lamp  lights up.
- Switch off the ignition by turning the orange programming key to the position **OFF** ☒.
- Pull out the orange programming key.
- Insert the black ignition key in the ignition lock.
- Switch on the ignition by turning the black ignition key to the position **ON** ○.
 - ✓ Immobilizer indicator lamp  lights up.

- Switch off the ignition by turning the black ignition key to the position **OFF** ☒.
- Remove the black ignition key.
- Insert the orange programming key in the ignition lock.
- Switch on the ignition by turning the orange programming key to the position **ON** ○.
- ✓ The immobilizer indicator lamp ■ flashes according to the number of functional black ignition keys including the orange programming key. In this case, it flashes twice.
- Switch off the ignition by turning the orange programming key to the position **OFF** ☒.
- Pull out the orange programming key.
- ✓ The lost black ignition key is deactivated.
- ✓ The existing black ignition key is reactivated.

Loss of all black ignition keys (no black ignition keys are available):

This procedure is important to prevent misuse of the lost black ignition key.

- Press the emergency OFF switch to the position **ON** ○.

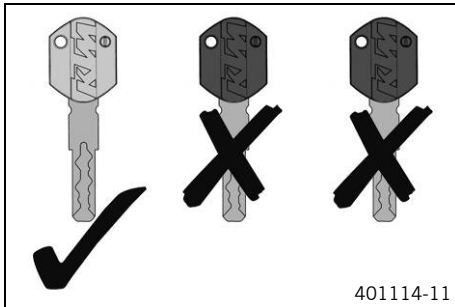

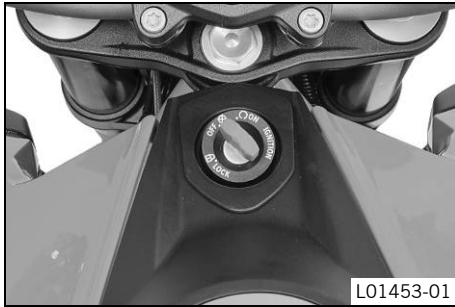

- Insert the orange programming key in the ignition lock.
- Switch on the ignition by turning the orange programming key to the position **ON** ○.
- ✓ Immobilizer indicator lamp ■ lights up.
- Switch off the ignition by turning the orange programming key to the position **OFF** ⊗.
- Switch on the ignition by turning the orange programming key to the position **ON** ○.
- ✓ The immobilizer indicator lamp ■ flashes according to the number of functional black ignition keys including the orange programming key. In this case, it flashes once since all black ignition keys are deactivated.
- Switch off the ignition by turning the orange programming key to the position **OFF** ⊗.
- Pull out the orange programming key.
- ✓ All black ignition keys are deactivated.
- Order a new black ignition key according to the key number on the **KEYCODECARD** and activate it.

To activate up to three black ignition keys:

- Press the emergency OFF switch to the position **ON** ○.
- Insert the orange programming key in the ignition lock.
- Switch on the ignition by turning the orange programming key to the position **ON** ○.
- ✓ Immobilizer indicator lamp ■ lights up.
- Switch off the ignition by turning the orange programming key to the position **OFF** ⊗.
- Pull out the orange programming key.
- Insert the black ignition key in the ignition lock.
- Switch on the ignition by turning the black ignition key to the position **ON** ○.
- ✓ Immobilizer indicator lamp ■ lights up.
- Switch off the ignition by turning the black ignition key to the position **OFF** ⊗.
- Remove the black ignition key.
- If two other black ignition keys are to be activated, repeat the last steps with the respective ignition key.

- If the last black ignition key was activated, insert the orange programming key into the ignition lock.
- Switch on the ignition by turning the orange programming key to the position **ON** ○.
- ✓ The immobilizer indicator lamp ■ flashes according to the number of functional black ignition keys including the orange programming key.
- Switch off the ignition by turning the orange programming key to the position **OFF** ⊗.
- Pull out the orange programming key.



Info

Activation of the ignition key is finished.

To activate four black ignition keys:

- Press the emergency OFF switch to the position **ON** ○.
- Insert the orange programming key in the ignition lock.
- Switch on the ignition by turning the orange programming key to the position **ON** ○.
- ✓ Immobilizer indicator lamp ■ lights up.
- Switch off the ignition by turning the orange programming key to the position **OFF** ⊗.
- Pull out the orange programming key.
- Insert the black ignition key in the ignition lock.
- Switch on the ignition by turning the black ignition key to the position **ON** ○.
- ✓ Immobilizer indicator lamp ■ lights up.
- Switch off the ignition by turning the black ignition key to the position **OFF** ⊗.
- Remove the black ignition key.
- If three other black ignition keys are to be activated, repeat the last steps with the respective ignition key.

**Info**

After the fourth black ignition key has been activated, programming is finished.

17.1 Checking the coolant level in the compensating tank



Warning

Danger of scalding During motorcycle operation, the coolant gets very hot and is under pressure.

- Do not remove the radiator cap, radiator hoses or other cooling system components when the engine is hot. Allow the engine and cooling system to cool down. In case of scalding, rinse immediately with lukewarm water.



Warning

Danger of poisoning Coolant is poisonous and a health hazard.

- Coolant must not come into contact with the skin, eyes, or clothing. If contact occurs with the eyes, rinse with water immediately and contact a physician. Immediately clean contaminated areas on the skin with soap and water. If coolant is swallowed, contact a physician immediately. Change clothing that is contaminated with coolant. Keep coolant out of reach of children.

Condition

The engine is cold.

The radiator is completely full.

- Park the motorcycle on a horizontal surface.
- Check the coolant level in the compensating tank **1**.

The coolant level must be between **MIN** and **MAX**.

- » If there is no coolant in the compensating tank:
 - Check the cooling system for leaks. 🛠️



Info

Do not start up the motorcycle!

- Add coolant/bleed the cooling system. 🛠️
- » If the coolant in the compensating tank is not at the required level, but the tank is not empty:

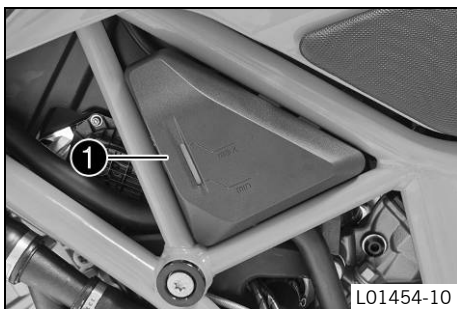

- Correct the coolant level in the compensating tank. (🔧 p. 151)

17.2 Correcting the coolant level in the compensating tank



Warning

Danger of scalding During motorcycle operation, the coolant gets very hot and is under pressure.

- Do not remove the radiator cap, radiator hoses or other cooling system components when the engine is hot. Allow the engine and cooling system to cool down. In case of scalding, rinse immediately with lukewarm water.



Warning

Danger of poisoning Coolant is poisonous and a health hazard.

- Coolant must not come into contact with the skin, eyes, or clothing. If contact occurs with the eyes, rinse with water immediately and contact a physician. Immediately clean contaminated areas on the skin with soap and water. If coolant is swallowed, contact a physician immediately. Change clothing that is contaminated with coolant. Keep coolant out of reach of children.

Condition

The engine is cold.

The radiator is completely full.

Preparatory work

- Check the coolant level in the compensating tank. (🔧 p. 150)



Main work

- Pull off the compensating tank toward the bottom and maneuver it out.

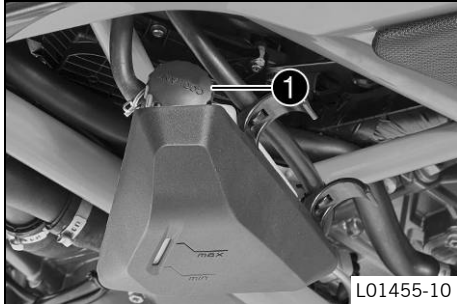

- Remove cover ❶ of the compensating tank.
- Add coolant to the **MAX** marking.

Coolant (☛ p. 185)

- Mount the cover of the compensating tank.
- Mount the compensating tank.

18.1 "Drive Mod"

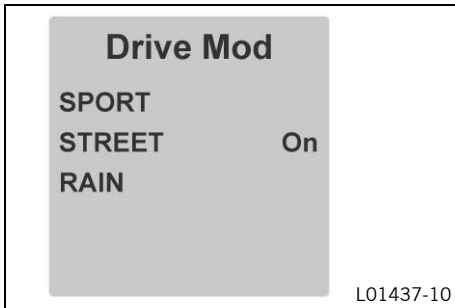

Possible states

- SPORT – Homologated performance with very direct response; the traction control allows greater slip on the rear wheel
- STREET – Homologated performance with balanced response; the traction control allows normal slip on the rear wheel
- RAIN – Reduced homologated performance for better rideability; the traction control allows normal slip on the rear wheel

Various vehicle tunings can be selected in the **"Drive Mod"** menu. You can choose from **"SPORT"**, **"STREET"**, and **"RAIN"**.

The drive mode selected last is displayed on the right in the segment display.



Info

The drive mode selection has no influence on the ABS.

18.2 MTC/motorcycle traction control

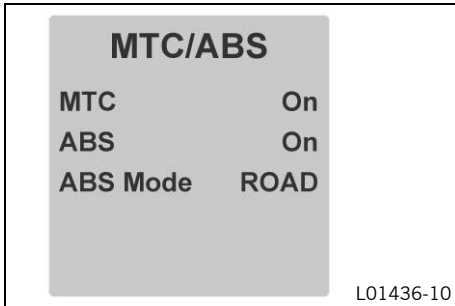

The traction control lowers engine torque in case of loss of traction in the rear wheel.





Info

When traction control is switched off, the rear wheel may spin during high acceleration and on surfaces with low grip.
After the ignition is switched back on, traction control is enabled again.

Traction control is controlled via the **"Drive Mod"** (☛ p. 153) menu on the combination instrument. Traction control can be switched off in the **"MTC/ABS"** menu.



Info

When traction control is active, the TC lamp  flashes.
When traction control is switched off, the TC lamp  is lit.

19.1 Checking the engine oil level



Info

Oil consumption depends on the riding style and the operating conditions.

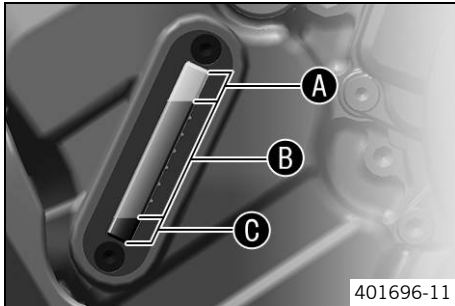

Condition

The engine is at operating temperature.

Preparatory work

- Stand the motorcycle upright on a horizontal surface.

Main work

- Check the engine oil level in the engine oil level viewer.



Info

After switching off the engine, wait one minute before checking the level.

The engine oil level should be in the upper area **B** of the engine oil level viewer.

- » When the engine oil level is in area **A** of the engine oil level viewer:
 - Do not add engine oil.
- » When the engine oil level is in area **B** of the engine oil level viewer:
 - Engine oil can be added.
- » When the engine oil level is in area **C** of the engine oil level viewer:
 - Add engine oil. (🔧 p. 159)

19.2 Changing the engine oil and filter, cleaning the oil screens ↴

-  **Warning**
Danger of scalding Engine oil and gear oil get very hot when the motorcycle is ridden.
- Wear appropriate protective clothing and safety gloves. In case of burns, rinse immediately with lukewarm water.

-  **Warning**
Environmental hazard Hazardous substances cause environmental damage.
- Oil, grease, filters, fuel, cleaners, brake fluid, etc., should be disposed of as stipulated in applicable regulations.

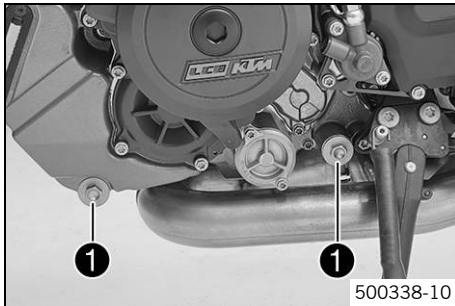

Main work

- Stand the motorcycle on its side stand on a horizontal surface.
- Place a suitable container under the engine.
- Remove the oil drain plugs **1** with the magnet, O-rings, and oil screen.

19 SERVICE WORK ON THE ENGINE

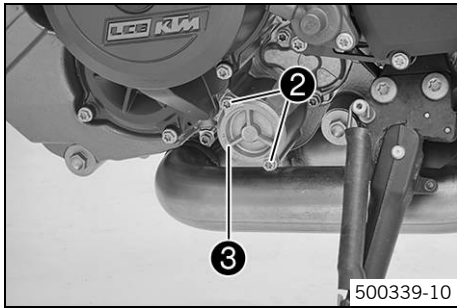

- Remove screws **2**. Remove the oil filter cover **3** with the O-ring.

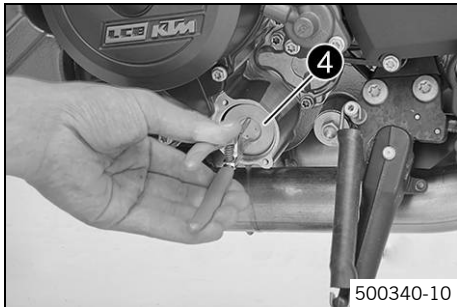

- Pull oil filter **4** out of the oil filter housing.

Circlip pliers reverse (51012011000)

- Completely drain the engine oil.
- Thoroughly clean the parts and sealing surface.

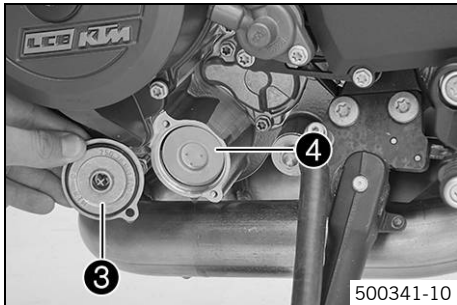

- Insert the new oil filter **4**.
- Lubricate the O-ring of the oil filter cover. Mount the oil filter cover **3**.

19 SERVICE WORK ON THE ENGINE

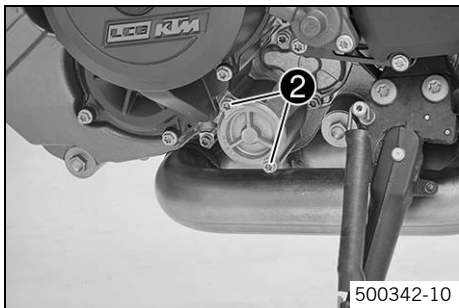

- Mount and tighten screws **2**.

Guideline

Remaining engine screws	M5	6 Nm (4.4 lbf ft)
-------------------------	----	-------------------

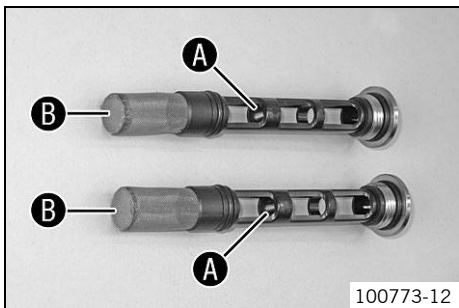

- Thoroughly clean magnet **A** and oil screen **B** of the oil drain plugs.

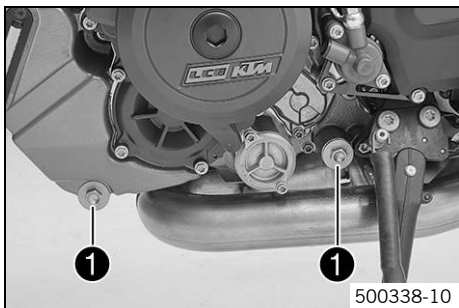

- Mount and tighten the oil drain plugs **1** with the magnet, O-rings, and oil screen.

Guideline

Oil drain plug	M20x1.5	20 Nm (14.8 lbf ft)
----------------	---------	------------------------

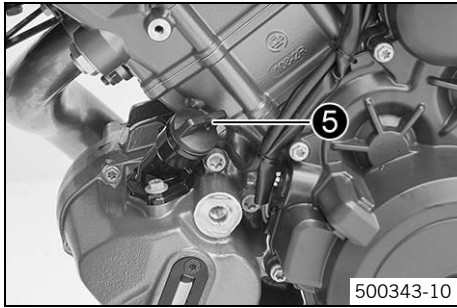

- The oil must be added in two steps.

Engine oil	3.60 l (3.8 qt.)	Outside temperature: ≥ 0 °C (≥ 32 °F)	Engine oil (SAE 10W/50) (☛ p. 185)
		Outside temperature: < 0 °C (< 32 °F)	Engine oil (SAE 5W/40) (☛ p. 186)

- Remove screw plug **5** and fill in engine oil.

Engine oil (1st quantity), approx.	3.0 l (3.2 qt.)	Outside temperature: ≥ 0 °C (≥ 32 °F)	Engine oil (SAE 10W/50) (☛ p. 185)
		Outside temperature: < 0 °C (< 32 °F)	Engine oil (SAE 5W/40) (☛ p. 186)

- Mount screw plug **5**.



Danger

Danger of poisoning Exhaust gases are toxic and inhaling them may result in unconsciousness and/or death.

- When running the engine, always make sure there is sufficient ventilation, and do not start or run the engine in an enclosed space without an effective exhaust extraction system.
-
- Start the engine and check that it is oil-tight.

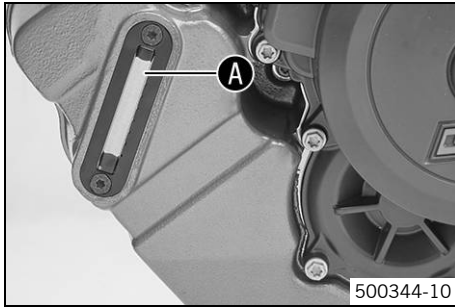

- Remove the screw plug and add the remaining engine oil to the upper marking **A** on the engine oil level viewer.
- Mount the screw plug.



Danger

Danger of poisoning Exhaust gases are toxic and inhaling them may result in unconsciousness and/or death.

- When running the engine, always make sure there is sufficient ventilation, and do not start or run the engine in an enclosed space without an effective exhaust extraction system.
-
- Start the engine and check that it is oil-tight.

Finishing work

- Check the engine oil level. (🔧 p. 154)

19.3 Adding engine oil



Info

Too little engine oil or poor-quality engine oil results in premature wear to the engine. The engine may be damaged if the engine oil level is too high.

Condition

The engine is at operating temperature.

Preparatory work

- Stand the motorcycle upright on a horizontal surface.
- Check the engine oil level. (🔧 p. 154)

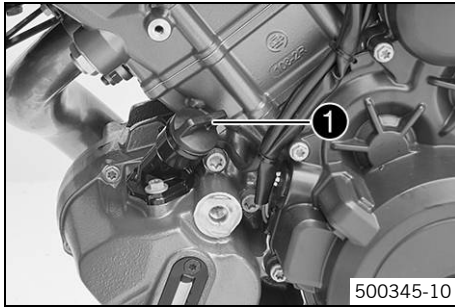

Main work

- Remove screw plug ①.

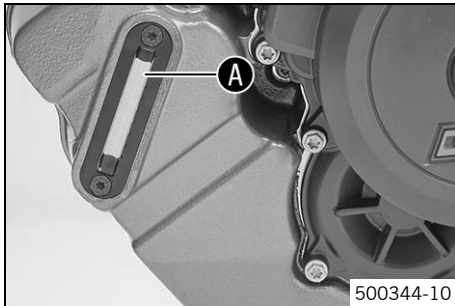

- Add engine oil to the upper marking ① on the engine oil level viewer.

Condition

Outside temperature: $\geq 0\text{ }^{\circ}\text{C}$ ($\geq 32\text{ }^{\circ}\text{F}$)

Engine oil (SAE 10W/50) (☛ p. 185)

Condition

Outside temperature: $< 0\text{ }^{\circ}\text{C}$ ($< 32\text{ }^{\circ}\text{F}$)

Engine oil (SAE 5W/40) (☛ p. 186)



Info

In order to achieve optimal engine performance, it is not advisable to mix different engine oils.

KTM recommends changing the engine oil.

- Mount the screw plug.



Danger

Danger of poisoning Exhaust gases are toxic and inhaling them may result in unconsciousness and/or death.

- When running the engine, always make sure there is sufficient ventilation, and do not start or run the engine in an enclosed space without an effective exhaust extraction system.

-
- Start the engine and check that it is oil-tight.

Finishing work

- Check the engine oil level. (👉 p. 154)

20.1 Cleaning motorcycle

Note

Material damage Damage and destruction of components by high-pressure cleaning equipment.

- When cleaning the vehicle with a pressure cleaner, do not point the water jet directly onto electrical components, connectors, cables, bearings, etc. Maintain a minimum distance of 60 cm between the nozzle of the pressure cleaner and the component. Excessive pressure can cause malfunctions or destroy these parts.



Warning

Environmental hazard Hazardous substances cause environmental damage.

- Oil, grease, filters, fuel, cleaners, brake fluid, etc., should be disposed of as stipulated in applicable regulations.



Info

If you clean the motorcycle regularly, its value and appearance will be maintained over a long period.
Avoid direct sunshine on the motorcycle during cleaning.

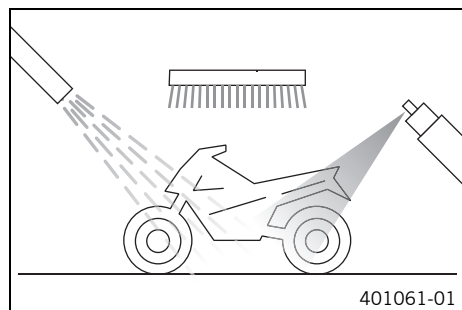

- Close off the exhaust system to keep water from entering.
- First remove coarse dirt particles with a gentle spray of water.
- Spray very dirty areas with a normal motorcycle cleaner and then clean with a brush.

Motorcycle cleaner (☛ p. 188)



Info

Use warm water containing normal motorcycle cleaner and a soft sponge.
Never apply motorcycle cleaner to a dry vehicle; always rinse the vehicle with water first.
If the vehicle was operated in road salt, clean it with cold water. Warm water would enhance the corrosive effects of salt.

- After rinsing the motorcycle with a gentle spray of water, allow it to dry thoroughly.
- Remove the closure of the exhaust system.



Warning

Danger of accidents Reduced braking efficiency due to a wet or dirty brake system.

- Clean or dry a dirty or wet brake system by riding and braking gently.

- After cleaning, ride the vehicle a short distance until the engine warms up.



Info

The heat produced causes water at inaccessible locations in the engine and on the brake system to evaporate.

- Push back the protection caps of the handlebar controls to allow any water that has penetrated to evaporate.
- After the motorcycle has cooled off, lubricate all moving parts and bearings.
- Clean the chain. (🔧 p. 97)
- Treat bare metal parts (except for brake discs and exhaust system) with corrosion inhibitor.

Preserving materials for paints, metal and rubber (🔧 p. 189)

- Treat the painted parts with a mild paint polish.

Perfect Finish and high gloss polish for paints (🔧 p. 189)



Info

Do not polish plastic parts that are matte when the vehicle is delivered as this would seriously impair the material quality.

- Treat the plastic parts and powder-coated parts with a mild cleaning and care product.

Special cleaner for glossy and matte paint finishes, metal and plastic surfaces (☛ p. 189)

- Oil the ignition/steering lock, tank lock, and seat lock.

Universal oil spray (☛ p. 189)

20.2 Checks and maintenance steps for winter operation

i Info

If you use the motorcycle in winter, you must expect salt on the roads. You should therefore take precautions against aggressive road salt.

If the vehicle was operated in road salt, clean it with cold water after riding. Warm water would enhance the corrosive effects of salt.

- Clean the motorcycle. (☛ p. 162)
- Clean the brakes.

i Info

After **EVERY** trip on salted roads, thoroughly wash the brake calipers and brake linings with cold water and dry carefully. This should be done after the parts are cooled down and while they are installed.

After riding on salted roads, thoroughly wash the motorcycle with cold water and dry it well.

- Treat the engine, the swingarm, and all other bare or galvanized parts (except brake discs) with a wax-based corrosion inhibitor.

i Info

Corrosion inhibitor must not come into contact with the brake discs. This would severely lower the braking effect.

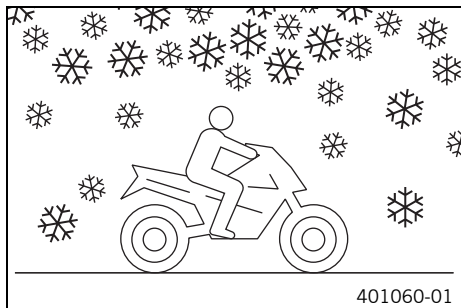

401060-01

- Clean the chain. (👉 p. 97)

21.1 Storage

i Info

If you plan to garage the motorcycle for a longer period, perform the following steps or have them performed. Before storing the motorcycle, check all parts for function and wear. If service, repairs or replacements are necessary, you should do this during the storage period (less workshop overload). In this way, you can avoid long workshop waiting times at the start of the new season.

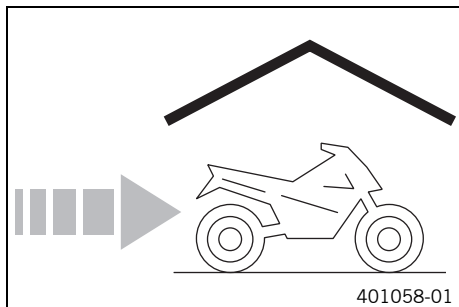

- When refueling for the last time before taking the motorcycle out of service, add fuel additive.

Fuel additive (☞ p. 188)

- Refuel. (☞ p. 76)
- Clean the motorcycle. (☞ p. 162)
- Change the engine oil and filter, clean the oil screens. 🛠️ (☞ p. 155)
- Check the coolant fill level and antifreeze. 🛠️
- Check the tire air pressure. (☞ p. 125)
- Remove the battery. 🛠️ (☞ p. 126)

Guideline

Storage temperature of battery without direct sunshine	0... 35 °C (32... 95 °F)
--	--------------------------

- Recharge the battery. 🛠️ (☞ p. 131)
- Store the vehicle in a dry location that is not subject to large fluctuations in temperature.

i Info

KTM recommends jacking up the motorcycle.

- Lift the motorcycle with the rear lifting gear. (☞ p. 89)

- Lift the motorcycle with the front lifting gear. (🔧 p. 90)
 - Cover the vehicle with a tarp or similar cover that is permeable to air.
-

i **Info**

Do not use non-porous materials since they prevent humidity from escaping, thus causing corrosion.

Avoid running the engine for a short time only. Since the engine cannot warm up properly, the water vapor produced during combustion condenses and causes valves and the exhaust system to rust.

21.2 Preparing for use after storage

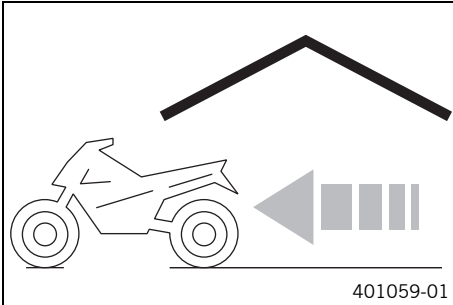

- Take the motorcycle from the front lifting gear. (🔧 p. 91)
 - Remove the rear of the motorcycle from the lifting gear. (🔧 p. 89)
 - Install the battery. 🔧 (🔧 p. 128)
-

i **Info**

If the battery was disconnected, the time and date must be set.

- Perform checks and maintenance measures when preparing for use. (🔧 p. 66)
- Take a test ride.

Faults	Possible cause	Action
The combination instrument shows nothing on the display	Fuse 1 is blown	– Change the fuses in the fuse box. (☞ p. 138)
	The main fuse is blown	– Change the main fuse. (☞ p. 135)
	The battery is discharged	– Recharge the battery. ☹ (☞ p. 131) – Check the open-circuit current. ☹
	The ignition/steering lock is faulty	– Check the ignition/steering lock. ☹
The engine does not crank when the electric starter button is pressed	The emergency OFF switch is off	– Press the emergency OFF switch to the position ON ○.
	Operating error	– Carry out the start procedure. (☞ p. 67)
	The battery is discharged	– Recharge the battery. ☹ (☞ p. 131) – Check the open-circuit current. ☹
	The safety start system is faulty	– Read out the fault memory using the KTM diagnostics tool. ☹
	CAN bus communication error	– Read out the fault memory using the KTM diagnostics tool. ☹
	Fault in EFI control unit.	– Read out the fault memory using the KTM diagnostics tool. ☹
	Fault in the MCU control unit.	– Read out the fault memory using the KTM diagnostics tool. ☹
The engine only turns if the clutch lever is drawn	The vehicle is in gear	– Shift the transmission to idle N .
	The safety start system is faulty	– Read out the fault memory using the KTM diagnostics tool. ☹
The engine turns although a gear is engaged	The safety start system is faulty	– Read out the fault memory using the KTM diagnostics tool. ☹
The engine turns but does not start	The coupling of the fuel hose connection is not connected	– Reconnect the coupling of the fuel hose connection.

Faults	Possible cause	Action
The engine turns but does not start	Defect in the fuel injection system	– Read out the fault memory using the KTM diagnostics tool. 🛠️
	The fuel quality is insufficient	– Add suitable fuel.
The engine dies during the trip	Lack of fuel	– Refuel. (🔧 p. 76)
	Defect in the fuel injection system	– Read out the fault memory using the KTM diagnostics tool. 🛠️
The engine warning lamp lights up/flashes	Defect in the fuel injection system	– Read out the fault memory using the KTM diagnostics tool. 🛠️
The ABS warning lamp lights up	The ABS fuse is blown	– Change the fuses in the fuse box. (🔧 p. 138)
	Large difference in wheel speeds of the front and rear wheels	– Stop the vehicle, switch off the ignition, and start it again.
	Malfunction in ABS	– Read out the fault memory using the KTM diagnostics tool. 🛠️
High oil consumption	The engine oil level is too high	– Check the engine oil level. (🔧 p. 154)
	The engine oil is too thin (low viscosity)	– Change the engine oil and filter, clean the oil screens. 🛠️ (🔧 p. 155)
The battery is discharged	The hazard warning flasher is switched on	– Switch off the hazard warning flasher. – Recharge the battery. 🛠️ (🔧 p. 131)
	The battery is not being charged by the alternator	– Check the charging voltage. 🛠️
	The ignition was not switched off while the vehicle was parked	– Recharge the battery. 🛠️ (🔧 p. 131)

23.1 engine

Design	2-cylinder 4-stroke Otto engine, 75° V arrangement, water-cooled
Displacement	1,301 cm ³ (79.39 cu in)
Stroke	71 mm (2.8 in)
Bore	108 mm (4.25 in)
Compression ratio	13.2:1
Idle speed	1,300... 1,500 rpm
Control	DOHC, 4 valves per cylinder, chain-driven
Valve - valve stem diameter	
Intake	42 mm (1.65 in)
Exhaust	34 mm (1.34 in)
Valve clearance	
Exhaust at: 20 °C (68 °F)	0.25... 0.30 mm (0.0098... 0.0118 in)
Intake at: 20 °C (68 °F)	0.10... 0.15 mm (0.0039... 0.0059 in)
Crankshaft bearing	Sleeve bearing
Conrod bearing	Sleeve bearing
Piston	Forged light alloy
Piston ring	1 upper compression (rectangular) ring, 1 lower compression ring, 1 oil scraper ring
Engine lubrication	Dry sump lubrication system with three rotor pumps
Primary transmission	40:76
Clutch	Antihopping clutch in oil bath/hydraulically operated
Transmission	6-speed claw gears
Transmission ratio	

1st gear	12:35
2nd gear	15:32
3rd gear	18:30
4th gear	20:27
5th gear	24:27
6th gear	27:26
Mixture preparation	Electronically controlled fuel injection
Ignition system	Contactless controlled fully electronic ignition with digital ignition adjustment
Alternator	12 V, 450 W
Spark plug	
Inside spark plug	NGK LKAR9BI9
Outside spark plug	NGK LMAR7A-9
Electrode gap, spark plug	0.9 mm (0.035 in)
Cooling	Water cooling, permanent circulation of coolant by water pump
Cold start device	Electric starter

23.2 Engine tightening torques

Screw, damping plate	EJOT Altracs® M6x10	10 Nm (7.4 lbf ft)	Loctite® 243™
Screw, retaining bracket, valve cover, rear	EJOT Altracs® M6x10	10 Nm (7.4 lbf ft)	–
Hose clip, intake flange	M4	1.5 Nm (1.11 lbf ft)	–
Remaining engine screws	M5	6 Nm (4.4 lbf ft)	–
Screw, bearing retainer	M5	6 Nm (4.4 lbf ft)	Loctite® 243™
Screw, bearing shell retaining bracket	M5	6 Nm (4.4 lbf ft)	Loctite® 243™

23 TECHNICAL DATA

Screw, engine oil level viewer	M5	4 Nm (3 lbf ft)	–
Screw, gear sensor	M5	6 Nm (4.4 lbf ft)	Loctite® 243™
Screw, pulse generator	M5	6 Nm (4.4 lbf ft)	Loctite® 243™
Bleeder screw, water pump cover	M6	10 Nm (7.4 lbf ft)	–
Freewheel ring bolt	M6 – 10.9	15 Nm (11.1 lbf ft)	Loctite® 648™
Nut, cylinder head	M6	9 Nm (6.6 lbf ft)	–
Plug, vacuum connection	M6	5 Nm (3.7 lbf ft)	Loctite® 243™
Remaining engine screws	M6	10 Nm (7.4 lbf ft)	–
Screw, camshaft bearing support	M6 – 10.9	10 Nm (7.4 lbf ft)	–
Screw, clutch cover	M6	10 Nm (7.4 lbf ft)	–
Screw, clutch spring	M6	12 Nm (8.9 lbf ft)	–
Screw, coolant connection on cylinder head	M6	10 Nm (7.4 lbf ft)	–
Screw, engine case	M6x60	10 Nm (7.4 lbf ft)	–
Screw, engine case	M6x80	10 Nm (7.4 lbf ft)	–
Screw, engine case	M6x90	10 Nm (7.4 lbf ft)	–
Screw, freewheel holder	M6	10 Nm (7.4 lbf ft)	Loctite® 243™
Screw, locking lever	M6	10 Nm (7.4 lbf ft)	Loctite® 243™
Screw, oil pump cover	M6	10 Nm (7.4 lbf ft)	Loctite® 243™
Screw, shift drum locating	M6	10 Nm (7.4 lbf ft)	Loctite® 243™
Screw, shift lever	M6	10 Nm (7.4 lbf ft)	Loctite® 243™
Screw, starter motor	M6	10 Nm (7.4 lbf ft)	–
Screw, stator	M6	10 Nm (7.4 lbf ft)	Loctite® 243™
Screw, valve cover	M6	10 Nm (7.4 lbf ft)	–
Screw, water pump cover	M6	10 Nm (7.4 lbf ft)	–

23 TECHNICAL DATA

Screw, water pump wheel	M6	10 Nm (7.4 lbf ft)	Loctite® 243™
Stud, chain shaft	M6	8 Nm (5.9 lbf ft)	–
Vacuum connection	M6	2.5 Nm (1.84 lbf ft)	Loctite® 243™
Nozzle 100	M6x0.75	4 Nm (3 lbf ft)	Loctite® 243™
Oil nozzle	M6x0.75	4 Nm (3 lbf ft)	Loctite® 243™
Plug, crankshaft retainer	M8	15 Nm (11.1 lbf ft)	–
Screw, camshaft bearing support	M8 – 10.9	Step 1 10 Nm (7.4 lbf ft) Step 2 18 Nm (13.3 lbf ft)	–
Screw, engine case	M8	18 Nm (13.3 lbf ft)	–
Screw, timing chain guide rail	M8	15 Nm (11.1 lbf ft)	Loctite® 243™
Screw, timing chain tensioning rail	M8	15 Nm (11.1 lbf ft)	Loctite® 243™
Stud, exhaust flange	M8	10 Nm (7.4 lbf ft)	–
Screw, engine bearer	M10	45 Nm (33.2 lbf ft)	–
Oil pressure sensor	M10x1	10 Nm (7.4 lbf ft)	–
Plug, cam lever axis	M10x1	15 Nm (11.1 lbf ft)	–
Plug, clutch lubrication	M10x1	10 Nm (7.4 lbf ft)	–
Screw plug, spread transmission lock	M10x1	12 Nm (8.9 lbf ft)	–
Screw, conrod bearing	M10x1	Step 1 25 Nm (18.4 lbf ft) Step 2 30 Nm (22.1 lbf ft) Step 3 90°	–
Screw, timing chain tensioner release	M10x1	10 Nm (7.4 lbf ft)	–

Spark plug	M10x1	11 Nm (8.1 lbf ft)	–
Cylinder head screw	M11x1.5	Tightening sequence: Using a crisscross pattern Step 1 15 Nm (11.1 lbf ft) Step 2 30 Nm (22.1 lbf ft) Step 3 90° Step 4 90°	Lubricated with engine oil
Coolant temperature sensor	M12x1.5	12 Nm (8.9 lbf ft)	–
Rotor screw	M12x1.5	90 Nm (66.4 lbf ft)	–
Spark plug	M12x1.5	18 Nm (13.3 lbf ft)	–
Nut of engine sprocket	M20x1.5	100 Nm (73.8 lbf ft)	Loctite® 243™
Oil drain plug	M20x1.5	20 Nm (14.8 lbf ft)	–
Nut, inner clutch hub	M22x1.5	130 Nm (95.9 lbf ft)	Loctite® 243™
Plug, timing-chain tensioner	M24x1.5	25 Nm (18.4 lbf ft)	–
Screw in alternator cover	M24x1.5	8 Nm (5.9 lbf ft)	–
Nut, primary gear	M33LHx1.5	130 Nm (95.9 lbf ft)	Loctite® 243™

23.3 Capacities

23.3.1 Engine oil

Engine oil	3.60 l (3.8 qt.)	Outside temperature: $\geq 0\text{ }^{\circ}\text{C}$ ($\geq 32\text{ }^{\circ}\text{F}$)	Engine oil (SAE 10W/50) (☛ p. 185)
------------	------------------	--	---------------------------------------

Engine oil	3.60 l (3.8 qt.)	Outside temperature: < 0 °C (< 32 °F)	Engine oil (SAE 5W/40) (☛ p. 186)
------------	------------------	---------------------------------------	-----------------------------------

23.3.2 Coolant

Coolant	3.20 l (3.38 qt.)	Coolant (☛ p. 185)
		Coolant (☛ p. 185)

23.3.3 Fuel

Total fuel tank capacity, approx.	18 l (4.8 US gal)	Super unleaded (ROZ 95/RON 95/PON 91) (☛ p. 187)
Fuel reserve, approx.	3.5 l (3.7 qt.)	

23.4 Chassis

Frame	Lattice frame made of chrome molybdenum steel tubing, powder-coated	
Fork	WP Suspension 4860 ROTA SPLIT	
Shock absorber	WP Suspension 4618 BAVP DCC	
Suspension travel		
Front	125 mm (4.92 in)	
Rear	156 mm (6.14 in)	
Brake system		
Front	Double disc brake with radially mounted four-pot brake calipers, floating brake discs	
Rear	Single disc brake with dual-piston brake caliper, fixed brake disc	
Brake discs - diameter		

Front	320 mm (12.6 in)
Rear	240 mm (9.45 in)
Brake discs - wear limit	
Front	4.5 mm (0.177 in)
Rear	4.5 mm (0.177 in)
Tire air pressure, solo/with passenger/full payload	
Front: with cold tires	2.5 bar (36 psi)
Rear: with cold tires	2.9 bar (42 psi)
Secondary drive ratio	17:38
Chain	5/8 x 5/16" (525) X-ring
Steering head angle	65.1°
Wheelbase	1,482 mm (58.35 in)
Seat height unloaded	835 mm (32.87 in)
Ground clearance unloaded	141 mm (5.55 in)
Weight without fuel approx.	189 kg (417 lb.)
Maximum permissible front axle load	160 kg (353 lb.)
Maximum permissible rear axle load	260 kg (573 lb.)
Maximum permissible overall weight	406 kg (895 lb.)

23.5 Electrical system

Battery	YTX14-BS	Battery voltage: 12 V Nominal capacity: 12 Ah Maintenance-free
Fuse	58011109110	10 A
Fuse	58011109115	15 A

Fuse	58011109125	25 A
Fuse	58011109130	30 A
Low beam/high beam	H4/socket U37R	12 V 60/55 W
Parking light	LED	
Instrument lights and indicator lamps	LED	
Turn signal	LED	
Tail light	LED	
Brake light	LED	
License plate lamp	LED	

23.6 Tires

Front tires	Rear tires
120/70 ZR 17 M/C 58W TL Dunlop Sportmax Sportsmart ²	190/55 ZR 17 M/C 75W TL Dunlop Sportmax Sportsmart ²
Additional information is available in the Service section under: http://www.ktm.com	

23.7 Fork

Fork part number	14.18.8N.22
Fork	WP Suspension 4860 ROTA SPLIT
Compression damping	
Comfort	17 clicks
Standard	12 clicks

Sport	7 clicks	
Full payload	7 clicks	
Rebound damping		
Comfort	17 clicks	
Standard	12 clicks	
Sport	7 clicks	
Full payload	7 clicks	
Spring length with preload spacer(s)	253 mm (9.96 in)	
Spring rate		
Medium (standard)	9.5 N/mm (54.2 lb/in)	
Fork length	776 mm (30.55 in)	
Air chamber length	110 \pm ₃₀ ¹⁰ mm (4.33 \pm _{1.18} ^{0.39} in)	
Fork oil per fork leg	660 ml (22.31 fl. oz.)	Fork oil (SAE 4) (48601166S1) (☛ p. 186)

23.8 Shock absorber

Shock absorber part number	15.18.7N.22	
Shock absorber	WP Suspension 4618 BAVP DCC	
Compression damping, low-speed		
Comfort	18 clicks	
Standard	15 clicks	
Sport	10 clicks	
Full payload	10 clicks	
Compression damping, high-speed		
Comfort	1.5 turns	

Standard	1.5 turns
Sport	1 turn
Full payload	1 turn
Rebound damping	
Comfort	15 clicks
Standard	12 clicks
Sport	9 clicks
Full payload	9 clicks
Spring preload	
Comfort	5 mm (0.2 in)
Standard	5 mm (0.2 in)
Sport	6 mm (0.24 in)
Full payload	7 mm (0.28 in)
Spring rate	
Medium (standard)	170 N/mm (971 lb/in)
Spring length	185 mm (7.28 in)
Gas pressure	10 bar (145 psi)
Riding sag	45 mm (1.77 in)
Static sag (standard)	24 mm (0.94 in)
Static sag (race track operation)	18 mm (0.71 in)
Fitted length	383 mm (15.08 in)
Shock absorber fluid (☛ p. 187)	SAE 2.5

23.9 Chassis tightening torques

Remaining screws, chassis	EJOT PT® K50x12	1 Nm (0.7 lbf ft)	–
Remaining screws, chassis	EJOT PT® K50x14	1 Nm (0.7 lbf ft)	–
Remaining screws, chassis	EJOT PT® K50x16	2 Nm (1.5 lbf ft)	–
Remaining screws, chassis	EJOT PT® K50x18	2 Nm (1.5 lbf ft)	–
Screw, fuel tank cover, quick connect nipple	EJOT PT® K60	2 Nm (1.5 lbf ft)	–
Screw, tail light	EJOT PT® K50x14	2.5 Nm (1.84 lbf ft)	–
Screw, combination switch, left	M4	2.5 Nm (1.84 lbf ft)	–
Screw, side stand switch	M4	2 Nm (1.5 lbf ft)	–
Remaining nuts, chassis	M5	5 Nm (3.7 lbf ft)	–
Remaining screws, chassis	M5	5 Nm (3.7 lbf ft)	–
Screw, cable channel	M5	5 Nm (3.7 lbf ft)	–
Screw, chain sliding guard	M5	5 Nm (3.7 lbf ft)	–
Screw, combination switch, right	M5	3.5 Nm (2.58 lbf ft)	–
Screw, cover part	M5x12	3.5 Nm (2.58 lbf ft)	–
Screw, filler cap	M5	3 Nm (2.2 lbf ft)	–
Screw, fuel level indicator	M5	3 Nm (2.2 lbf ft)	–
Screw, shock absorber adjusting ring	M5	5 Nm (3.7 lbf ft)	–
Ground fitting on frame	M6	10 Nm (7.4 lbf ft)	–
Nut, ABS unit attachment	M6	5 Nm (3.7 lbf ft)	–
Nut, cable on starter motor	M6	4 Nm (3 lbf ft)	–
Remaining nuts, chassis	M6	10 Nm (7.4 lbf ft)	–
Remaining screws, chassis	M6	10 Nm (7.4 lbf ft)	–

23 TECHNICAL DATA

Screw, ball joint of push rod on foot brake cylinder	M6	5 Nm (3.7 lbf ft)	Loctite® 243™
Screw, battery terminal	M6	4.5 Nm (3.32 lbf ft)	–
Screw, clutch assembly	M6	5 Nm (3.7 lbf ft)	Loctite® 243™
Screw, connecting piece, rear brake line	M6	10 Nm (7.4 lbf ft)	Loctite® 243™
Screw, cooler retaining bracket	M6	7 Nm (5.2 lbf ft)	–
Screw, exhaust clamp on main silencer	M6	8 Nm (5.9 lbf ft)	–
Screw, exhaust clamp on manifold	M6	8 Nm (5.9 lbf ft)	–
Screw, foot brake cylinder	M6	10 Nm (7.4 lbf ft)	Loctite® 243™
Screw, fuel pump	M6	6 Nm (4.4 lbf ft)	–
Screw, headlight mask, rear wall	M6	5 Nm (3.7 lbf ft)	–
Screw, license plate holder on lower rear panel	M6	12 Nm (8.9 lbf ft)	–
Screw, radiator hose clamp	M6	3 Nm (2.2 lbf ft)	–
Screw, sensor box	M6	6 Nm (4.4 lbf ft)	Loctite® 243™
Screw, shift lever stub	M6	10 Nm (7.4 lbf ft)	Loctite® 243™
Screw, shift rod	M6	5 Nm (3.7 lbf ft)	Loctite® 243™
Screw, shift shaft deflector on shift shaft	M6	18 Nm (13.3 lbf ft)	Loctite® 243™
Screw, side stand stub	M6	6 Nm (4.4 lbf ft)	Loctite® 243™
Screw, steering damper, holder, on frame	M6	8 Nm (5.9 lbf ft)	Loctite® 243™
Screw, step plate for foot brake lever	M6	10 Nm (7.4 lbf ft)	Loctite® 243™
Screw, wheel speed sensor, front	M6	4 Nm (3 lbf ft)	–
Screw, wheel speed sensor, rear	M6	4 Nm (3 lbf ft)	–

23 TECHNICAL DATA

Nut, manifold on cylinder head	M8	Tightening sequence: Tighten the nuts evenly. Do not warp the metal plate. 25 Nm (18.4 lbf ft)	–
Nut, rear sprocket	M8	36 Nm (26.6 lbf ft)	–
Nut, shift rod	M8	12 Nm (8.9 lbf ft)	–
Nut, shift rod	M8LH	12 Nm (8.9 lbf ft)	–
Nut, valve, angled	M8	4 Nm (3 lbf ft)	–
Remaining nuts, chassis	M8	25 Nm (18.4 lbf ft)	–
Remaining screws, chassis	M8	25 Nm (18.4 lbf ft)	–
Screw, axle clamp	M8	15 Nm (11.1 lbf ft)	–
Screw, bottom triple clamp	M8	12 Nm (8.9 lbf ft)	–
Screw, foot brake lever	M8	20 Nm (14.8 lbf ft)	Loctite® 243™
Screw, front brake disc	M8	30 Nm (22.1 lbf ft)	Loctite® 2701™
Screw, front rider footrest bracket	M8	25 Nm (18.4 lbf ft)	Loctite® 243™
Screw, handlebar clamp	M8	20 Nm (14.8 lbf ft)	–
Screw, ignition lock (tamper-proof screw)	M8	25 Nm (18.4 lbf ft)	–
Screw, rear brake caliper	M8	25 Nm (18.4 lbf ft)	Loctite® 2701™
Screw, rear brake disc	M8	30 Nm (22.1 lbf ft)	Loctite® 243™
Screw, shift lever on footrest bracket	M8	20 Nm (14.8 lbf ft)	Loctite® 243™
Screw, shift shaft deflector on frame	M8	10 Nm (7.4 lbf ft)	Loctite® 243™
Screw, side stand bracket	M8	25 Nm (18.4 lbf ft)	Loctite® 243™
Screw, side stand spring	M8	15 Nm (11.1 lbf ft)	Loctite® 2701™
Screw, steering damper on holder	M8	8 Nm (5.9 lbf ft)	Loctite® 243™

Screw, steering damper on triple clamp	M8	8 Nm (5.9 lbf ft)	Loctite® 243™
Screw, top triple clamp	M8	15 Nm (11.1 lbf ft)	–
Remaining nuts, chassis	M10	45 Nm (33.2 lbf ft)	–
Remaining screws, chassis	M10	45 Nm (33.2 lbf ft)	–
Screw, engine bearer	M10	45 Nm (33.2 lbf ft)	Loctite® 243™
Screw, front brake caliper	M10	45 Nm (33.2 lbf ft)	Loctite® 243™
Screw, instrument support	M10	40 Nm (29.5 lbf ft)	Loctite® 243™
Screw, side stand	M10	35 Nm (25.8 lbf ft)	Loctite® 243™
Screw, side stand bracket	M10	45 Nm (33.2 lbf ft)	Loctite® 243™
Screw, side stand retaining plate	M10	45 Nm (33.2 lbf ft)	Loctite® 243™
Banjo bolt, brake line	M10x1	25 Nm (18.4 lbf ft)	–
Banjo bolt, brake line, connecting piece, rear	M10x1	15 Nm (11.1 lbf ft)	–
Nut, rear hub shock absorber carrier	M10x1.25	45 Nm (33.2 lbf ft)	Loctite® 243™
Lambda sensor	M12x1.25	25 Nm (18.4 lbf ft)	–
Screw, bottom shock absorber	M14x1.5	80 Nm (59 lbf ft)	Thread greased
Screw, top shock absorber	M14x1.5	80 Nm (59 lbf ft)	Thread greased
Screw, eccentric	M16	70 Nm (51.6 lbf ft)	–
Nut, swingarm pivot	M19x1.5	130 Nm (95.9 lbf ft)	Thread greased
Nut, seat lock	M22x1.5	6 Nm (4.4 lbf ft)	–
Screw, steering head, top	M22x1.5	50 Nm (36.9 lbf ft)	–
Bolt, front axle	M25x1.5	45 Nm (33.2 lbf ft)	Thread greased

23 TECHNICAL DATA

Nut, steering head	M28x1.0	Step 1 10 Nm (7.4 lbf ft) Step 2 (loosen, counterclockwise) 60°	–
Nut, rear axle, shock absorber side	M35x1.5	200 Nm (147.5 lbf ft)	Loctite® 262™ /lock the locking wire with locking varnish
Nut, rear axle	M50x1.5	250 Nm (184.4 lbf ft)	Lock the locking wire with locking varnish

Brake fluid DOT 4 / DOT 5.1

Standard/classification

- DOT

Guideline

- Use only brake fluid that complies with the specified standard (see specifications on the container) and that exhibits the corresponding properties.

Recommended supplier

Castrol

- **RESPONSE BRAKE FLUID SUPER DOT 4**

Motorex®

- **Brake Fluid DOT 5.1**

Coolant

Guideline

- Only use high quality coolant with corrosion inhibitor for aluminum motors (even in countries with high temperatures). Using inferior antifreeze can result in corrosion and foaming.

Mixture ratio

Antifreeze protection: -25... -45 °C (-13... -49 °F)	anti-corrosion/antifreeze distilled water
--	--

Recommended supplier

Motorex®

- **COOLANT M3.0**

Engine oil (SAE 10W/50)

Standard/classification

- JASO T903 MA (☛ p. 190)
- SAE (☛ p. 190) (SAE 10W/50)

Guideline

- Use only engine oils that comply with the specified standards (see specifications on the container) and that possess the corresponding properties.

Fully synthetic engine oil

Recommended supplier

Motorex®

- Power Synt 4T

Engine oil (SAE 5W/40)

Standard/classification

- JASO T903 MA (☛ p. 190)
- SAE (☛ p. 190) (SAE 5W/40)

Guideline

- Use only engine oils that comply with the specified standards (see specifications on the container) and that possess the corresponding properties.

Synthetic engine oil

Recommended supplier

Motorex®

- Power Synt 4T

Fork oil (SAE 4) (48601166S1)

Standard/classification

- SAE (☛ p. 190) (SAE 4)

Guideline

- Use only oils that comply with the specified standards (see specifications on the container) and that exhibit the corresponding properties.

Hydraulic fluid (15)

Standard/classification

- ISO VG (15)

Guideline

- Use only hydraulic oil that complies with the specified standard (see specifications on the container) and that possesses the corresponding properties.

Recommended supplier

Motorex®

- Hydraulic Fluid 75

Shock absorber fluid (SAE 2.5) (50180751S1)

Standard/classification

- SAE (☛ p. 190) (SAE 2.5)

Guideline

- Use only oils that comply with the specified standards (see specifications on the container) and that exhibit the corresponding properties.

Super unleaded (ROZ 95/RON 95/PON 91)

Standard/classification

- DIN EN 228 (ROZ 95/RON 95/PON 91)

Guideline

- Only use unleaded super fuel that matches or is equivalent to the specified fuel grade.
- Fuel with an ethanol content of up to 10 % (E10 fuel) is safe to use.



Info

Do **not** use fuel containing methanol (e. g. M15, M85, M100) or more than 10 % ethanol (e. g. E15, E25, E85, E100).

Chain cleaner

Recommended supplier

Motorex®

- Chain Clean

Chain lube for road use

Guideline

Recommended supplier

Motorex®

- Chainlube Road

Fuel additive

Recommended supplier

Motorex®

- Fuel Stabilizer

Long-life grease

Recommended supplier

Motorex®

- Bike Grease 2000

Motorcycle cleaner

Recommended supplier

Motorex®

- Moto Clean

Perfect Finish and high gloss polish for paints

Recommended supplier

Motorex®

- Moto Polish & Shine

Preserving materials for paints, metal and rubber

Recommended supplier

Motorex®

- Moto Protect

Special cleaner for glossy and matte paint finishes, metal and plastic surfaces

Recommended supplier

Motorex®

- Quick Cleaner

Universal oil spray

Recommended supplier

Motorex®

- Joker 440 Synthetic

JASO T903 MA

Different technical development directions required a new specification for 4-stroke motorcycles – the JASO T903 MA Standard. Earlier, engine oils from the automobile industry were used for 4-stroke motorcycles because there was no separate motorcycle specification. Whereas long service intervals are demanded for automobile engines, high performance at high engine speeds are in the foreground for motorcycle engines. In most motorcycles, the gearbox and the clutch are lubricated with the same oil as the engine. The JASO MA Standard meets these special requirements.

SAE

The SAE viscosity classes were defined by the Society of Automotive Engineers and are used for classifying oils according to their viscosity. The viscosity describes only one property of oil and says nothing about quality.

A	
ABS	106
Accessories	13
Antilock brake system	106
Applying the brakes	72
Auxiliary substances	13
B	
Baggage lugs	34
Battery	
installing	128
recharging	131
removing	126
Brake discs	
checking	108
Brake fluid	
front brake, adding	109
rear brake, adding	113
Brake fluid level	
front brake, checking	109
rear brake, checking	112
Brake linings	
front brake, checking	111
rear brake, checking	115
Brake system	106-115
Brakes	72

C	
Capacity	
coolant	175
engine oil	158, 174-175
fuel	77, 175
Chain	
checking	101
cleaning	97
dirt, checking for	97
Chain guide	
checking	101
Chain tension	
checking	99
setting	100
Chassis number	20
Clutch	
fluid level, checking/correcting	104
Clutch lever	24
setting	57
Combination instrument	39-55
"ABS"	48
activation and test	39
"Clock/Date"	54
"Distance"	52
"Drive Mod"	49, 153
"DRL"	55
"Favorites"	44

"Fuel Cons"	53
"General Info"	46
"Heat Grip"	55
"Heat Grip" menu	48
indicator lamps	41
"Language"	51
matrix display	40
menu overview	50
message on the matrix display	42
"MTC"	48
overview	39
"Pressure"	53
segment display	40
service display	44
"Set Favorites"	46
"Settings"	47
shift warning light	43
"Shift Light"	54
"Temp"	52
"Trip 1"	45
"Trip 2"	45
"Warning"	47
Combination switch	25
overview	25
Coolant level	
compensating tank, checking	150
compensating tank, correcting	151
Customer service	14

E	
Electric starter button	29
Emergency OFF switch	28
Engine	
running in	63
Engine number	22
Engine oil	
adding	159
changing	155
Engine oil level	
checking	154
Engine sprocket	
checking	101
Environment	11
F	
Figures	14
Filler cap	
closing	32
opening	30
Foot brake lever	37
basic position, adjusting	58
Fork	81
compression damping, setting	81
rebound, adjusting	82
Fork part number	22

Front rider's seat

- mounting 93
- removing 92

Front wheel

- installing 117
- removing 116

Fuses

- in fuse box, changing 138

H

Hand brake lever 24

- basic position, adjusting 58

Handlebar position 56

- setting 56

Hazard warning flasher 26

Hazard warning flasher switch 26

Headlight

- daytime running light 126
- headlight range, adjusting 144

Headlight adjustment

- checking 143

Headlight bulb

- changing 141

Helmet lock 35

- mounting on the vehicle 93

Horn button 28

I

Ignition key

- activating/deactivating 145

Ignition lock 29

Immobilizer 30

Intended use 8

K

Key number 21

L

Light switch 26

Luggage 64

M

Main fuse

- changing 135

Main silencer

- installing 96
- removing 94

Matrix display

- menu 44

Motorcycle

- cleaning 162
- lifting with front lifting gear 90
- lifting with rear lifting gear 89
- removing the rear from the lifting gear 89
- taking from the front lifting gear 91

INDEX

Motorcycle traction control 153

MTC 153

O

Oil filter

changing 155

Oil screens

cleaning 155

Operating substances 13

Owner's Manual 12

P

Parking 74

Passenger footrests 36

Passenger seat

mounting 92

removing 91

Preparing for use

advice on first use 62

after storage 167

checks and maintenance measures when preparing for use . 66

Protective clothing 11

R

Rear sprocket

checking 101

Rear wheel

installing 121

removing 120

Refueling

fuel 76

Riding 68

starting off 68

S

Safe operation 10

Seat lock 33

Service 13

Service schedule 78-80

Shift lever 36

basic position, adjusting 60

basic position, checking 60

Shift lever stub

setting 61

Shifting 68

Shock absorber 81

compression damping, general 83

compression damping, high-speed, adjusting 85

compression damping, low-speed, adjusting 84

rebound damping, adjusting 86

spring preload, adjusting 86

Shock absorber part number 23

Side stand 38

Spare parts 13

Starting 67

Steering damper item number 23

INDEX

195

Steering lock	29
Step plate of foot brake lever	
setting	59
Stopping	74
Storage	166
Supporting strap	35
Suspension setting	81-88

Switches

on the left side of the handlebar	25
on the right side of the handlebar	28

T

Technical data

capacities	174
chassis	175
chassis tightening torques	180
electrical system	176
engine	170-184
engine tightening torques	171
fork	177
shock absorber	178
tires	177

Throttle grip	25
----------------------------	----

Tire air pressure

checking	125
----------------	-----

Tire condition

checking	123
----------------	-----

Tool set	34
Transport	75
Troubleshooting	168-169
Turn signal switch	27
Type label	20

U

Use definition	8
-----------------------------	---

V

Vehicle

loading	64
---------------	----

View of vehicle

front left	16
rear right	18

W

Warranty	13
-----------------------	----

Winter operation

checks and maintenance steps	164
------------------------------------	-----

Work rules	11
-------------------------	----



3213109en

10/2014



KTM Motorrad AG
3230 Mattighofen/Austria
<http://www.ktm.com>



Photo: Mitterbauer/KTM