

690 SMC R EU

Art. no. 3213316en



KTM

The work described in these setup instructions must be performed before the vehicle is delivered to the customer.

Read the setup instructions in their entirety before beginning work.

Print out the current **PDI** form found on the **KTM Dealer.net**.

These setup instructions were written to correspond to the latest state of this series. We reserve the right to make changes in the interest of technical advancement without at the same time updating this manual.

We shall not provide a description of general workshop methods. Likewise, safety rules that apply in a workshop are not specified here. It is assumed that the work will be performed by a fully trained mechanic.

All specifications are non-binding. KTM Sportmotorcycle GmbH specifically reserves the right to modify or delete technical specifications, prices, colors, forms, materials, services, designs, equipment, etc., without prior notice and without specifying reasons, to adapt these to local conditions, as well as to stop production of a particular model without prior notice. KTM accepts no liability for delivery options, deviations from illustrations and descriptions, misprints, and other errors. The models portrayed partly contain special equipment that does not belong to the regular scope of supply.

© 2015 KTM Sportmotorcycle GmbH, Mattighofen Austria

All rights reserved

Reproduction, even in part, as well as copying of all kinds, is permitted only with the express written permission of the copyright owner.



ISO 9001(12 100 6061)

According to the international quality management standard ISO 9001, KTM uses quality assurance processes that lead to the maximum possible quality of the products.

Issued by: TÜV Management Service

REG.NO. 12 100 6061

KTM Sportmotorcycle GmbH
5230 Mattighofen, Austria

1.1 Symbols used

The meaning of specific symbols is described below.



Indicates an expected reaction (e.g. of a work step or a function).



Indicates an unexpected reaction (e.g. of a work step or a function).



Indicates a page reference (more information is provided on the specified page).



Indicates information with more details or tips.



Indicates the result of a testing step.



Denotes a voltage measurement.



Denotes a current measurement.



Denotes a resistance measurement.

1.2 Formats used

The typographical formats used in this document are explained below.

Proprietary name	Identifies a proprietary name.
Name[®]	Identifies a protected name.
Brand[™]	Identifies a trademark.
<u>Underlined terms</u>	Refer to technical details of the vehicle or indicate technical terms, which are explained in the glossary.

2.1 Unpacking and setting up the vehicle

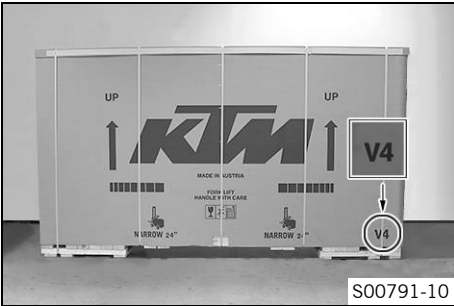

S00791-10

- Remove straps and box.

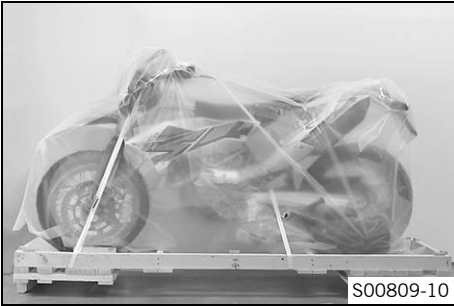

S00809-10

- Remove the adhesive tape in the upper area of the motorcycle.



S00810-10

- Roll down the film at the sides.

i Info

To avoid damaging the motorcycle during unpacking, leave the other films on the vehicle until you have finished work on the vehicle.

- Remove the separate enclosure and unpack it. Check the separate enclosure for completeness.
- Check the vehicle for transport damage.



S00794-10

- Remove the controls from the transport holder.
- Remove the screws and handlebar clamps.
- Remove the transport holder.

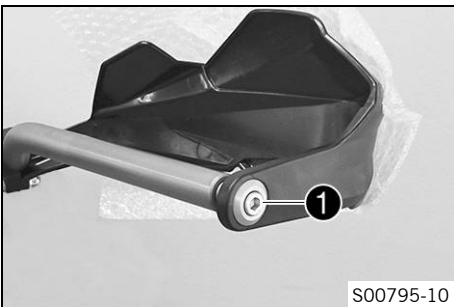

S00795-10

- Remove screw ❶ of the right hand guard.



S00796-10

- Position the controls on the right half of the handlebar.

i Info

The figure shows how to route the cable and lines.

- Mount the screws.

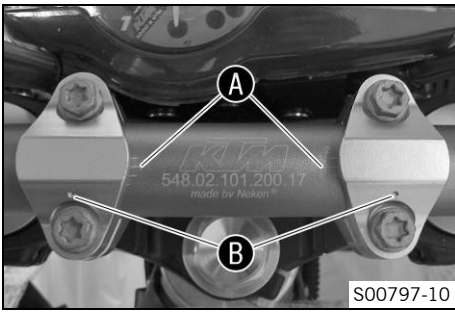

S00797-10

- Position the handlebar.
- Position the handlebar clamps. Mount the four screws and tighten evenly.

Guideline

Screw, handlebar clamp	M8	20 Nm (14.8 lbf ft)
------------------------	----	------------------------

- ✓ The marking **A** of the handlebar scale are located centrally between the handlebar clamps.
- ✓ Markings **B** face backwards.



S00798-10

- Position the controls on the left half of the handlebar.
- Mount the screws.

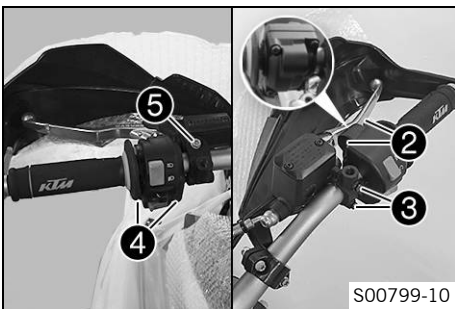

S00799-10

- Position all controls in their exact positions on the handlebar.
- Tighten screws **2** and **3**.

Guideline

Screw, throttle grip	M5	3.5 Nm (2.58 lbf ft)
Screw, brake assembly	M6	5 Nm (3.7 lbf ft)

- Check the throttle grip for smooth operation.
- Mount and tighten the screw of the right hand guard.
- Tighten screws **4** and **5**.

Guideline

Screw, combination switch, left	M5	3.5 Nm (2.58 lbf ft)
Screw, clutch assembly	M6	5 Nm (3.7 lbf ft)



K00062-01

- Mount and tighten the rear mirror adapter and rear mirror on both sides.

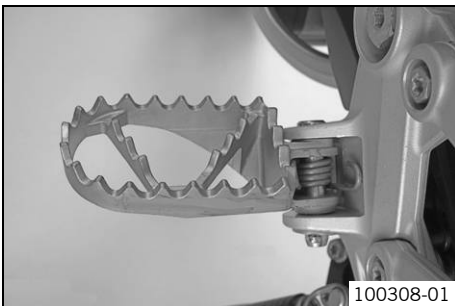

100308-01

- Mount the footrests with springs and pins. Secure the pins using washers and cotter pins.

Pliers for footrest spring (58429083000)

- Remove the protective plastic.
- Carefully loosen and remove the tensioning belt over the link fork.



Info

An assistant prevents the motorcycle from falling over.

- Carefully loosen and remove the tensioning belts around the lower triple clamp.
- ✓ The vehicle is released at the front.
- Together with an assistant, take the vehicle off the pallet.

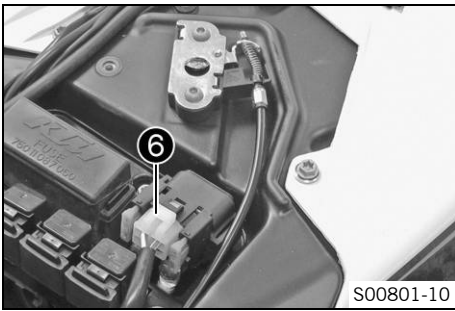

- Recharge the battery. (☛ p. 7)
- Install the battery. (☛ p. 8)
- Plug in connector 6 on the starter relay.

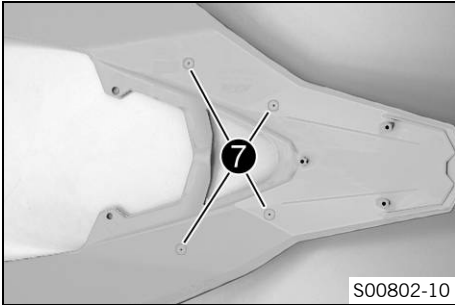

- Remove the rear fairing. (☛ p. 10)
- 4 markings 7 are found on the underside of the rear fairing. At these location, drill holes to the specified diameter in three stages.

Guideline

Hole diameter for grab handles	14.5 mm (0.571 in)
--------------------------------	--------------------

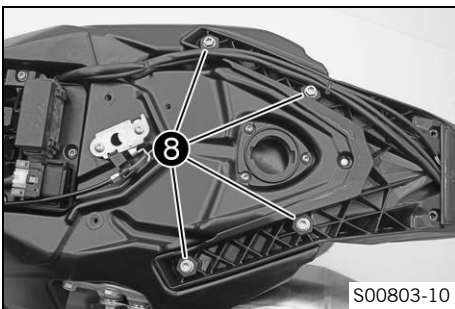

- Remove screws 8.
- Fit the rear fairing. (☛ p. 10)



- Mount the reflector.

Operation as a 2-seater

- Mount rear footrest bracket. (☛ p. 10)

Operation as a 1-seater (only if requested by customer)



Warning

Forfeiture of homologation and insurance cover The vehicle is homologated as 2-seater. If the heel protector is fitted instead of the footrest bracket, the vehicle no longer conforms to the homologation and must not be operated in this form without alterations to the registration papers.

- Set up and operate the vehicle as a 2-seater or have changes made to the registration papers.

- Mount heel protector. (☛ p. 11)
- Refuel. (☛ p. 11)
- Print out the current **PDI** form found on the **KTM Dealer.net** and perform the pre-delivery inspection.
- Set kilometers or miles. (☛ p. 12)

3.1 Removing the seat

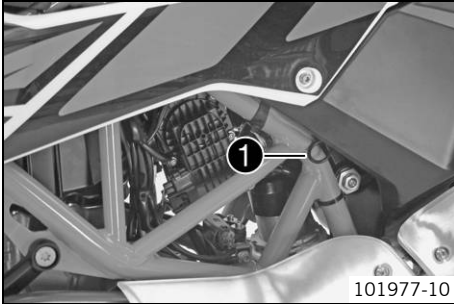

- Pull on strap ① and raise the rear of the seat at the same time.
- Pull back the seat and lift it off.

3.2 Mounting the seat



- Hook slot ① of the seat onto screw ②, press the rear downward and at the same time push it forward.
- Push locking pin ③ into lock housing ④ and push the back of the seat down until the locking pin locks in place with an audible click.
- Finally, check that the seat is correctly mounted.

3.3 Removing the battery



Warning

Risk of injury Battery acid and battery gases cause serious chemical burns.

- Keep batteries out of the reach of children.
- Wear suitable protective clothing and goggles.
- Avoid contact with battery acid and battery gases.
- Keep sparks and open flames away from the battery. Only charge in well-ventilated rooms.
- In the event of skin contact, rinse with large amounts of water. If battery acid gets in the eyes, rinse with water for at least 15 minutes and contact a physician.

Preparatory work

- Switch off all power consumers and switch off the engine.
- Remove the seat. (➔ p. 6)

Main work

- Remove battery cover ①.
- Pull the engine electronics control unit ② off of the holder and set it to one side.

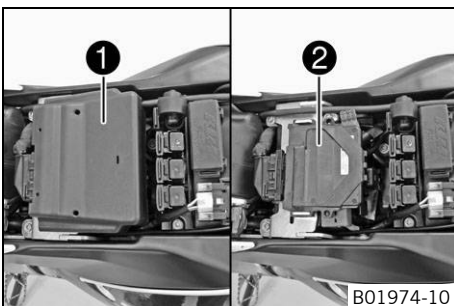

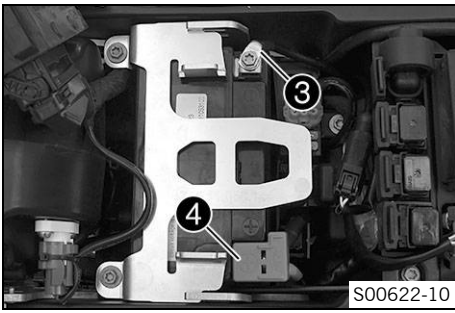

- Disconnect negative cable ③ of the battery.
- Take off the positive pole cover ④.

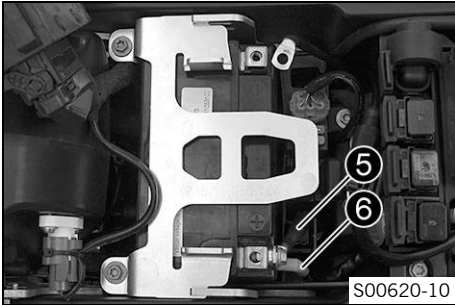

- Disconnect ABS connection cable ⑤ and positive cable ⑥ from the battery.

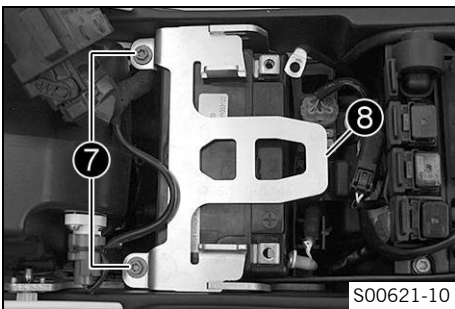

- Remove screws ⑦.
- Pull retaining bracket ⑧ of the battery forward and remove it.
- Remove the battery.

i Info

Never operate the motorcycle with a discharged battery or without a battery. In both cases, electrical components and safety devices can be damaged. The vehicle is therefore no longer roadworthy.

3.4 Recharging the battery



Warning

Risk of injury Battery acid and battery gases cause serious chemical burns.

- Keep batteries out of the reach of children.
- Wear suitable protective clothing and goggles.
- Avoid contact with battery acid and battery gases.
- Keep sparks and open flames away from the battery. Only charge in well-ventilated rooms.
- In the event of skin contact, rinse with large amounts of water. If battery acid gets in the eyes, rinse with water for at least 15 minutes and contact a physician.



Warning

Environmental hazard The battery contains elements that are harmful to the environment.

- Do not dispose of batteries with the household waste. Dispose of a defective battery in an environmentally friendly manner. Give the battery to your authorized KTM dealer or dispose of it at a collection point for used batteries.



Warning

Environmental hazard Hazardous substances cause environmental damage.

- Oil, grease, filters, fuel, cleaners, brake fluid, etc., should be disposed of as stipulated in applicable regulations.



Info

Even when there is no load on the battery, it still loses power steadily. The charging level and the method of charging are very important for the service life of the battery. Rapid recharging with a high charging current shortens the battery's service life. If the charging current, charging voltage and charging time are exceeded, electrolyte escapes through the safety valves. This reduces the battery capacity. If the battery is depleted from starting the vehicle repeatedly, the battery must be charged immediately. If the battery is left in a discharged state for an extended period, it will become over-discharged and sulfate, destroying the battery. The battery is maintenance-free, which means that the acid level does not need to be checked.

Preparatory work

- Switch off all power consumers and switch off the engine.
- Remove the seat. (☛ p. 6)
- Remove the battery. (☛ p. 6)

Main work

- Connect the battery charger to the battery. Switch on the battery charger.

Battery charger (58429074000)

You can also use the battery charger to test rest potential and start potential of the battery, and to test the alternator. With this device, you cannot overcharge the battery.

i Info

Never remove lid ❶.
Charge the battery with a maximum of 10% of the capacity specified on the battery housing ❷.

- Switch off the battery charger after charging and disconnect from the battery.

Guideline

The charge current, charge voltage and charge time must not be exceeded.

Charge the battery regularly when the motorcycle is not in use	3 months
--	----------



Finishing work

- Install the battery. (☛ p. 8)
- Mount the seat. (☛ p. 6)
- Set the clock. (☛ p. 12)

3.5 Installing the battery

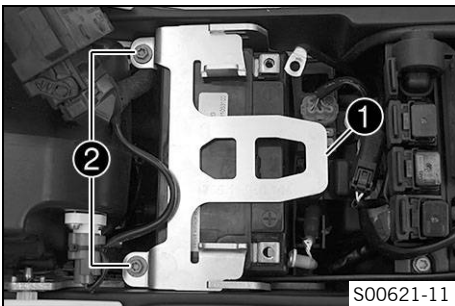

Main work

- Insert the battery into the battery compartment with the terminals facing rearward.

Battery (YTZ10S)

- Position retaining bracket ❶ and mount and tighten screws ❷.

Guideline

Remaining screws, chassis	M6	10 Nm (7.4 lbf ft)
---------------------------	----	--------------------

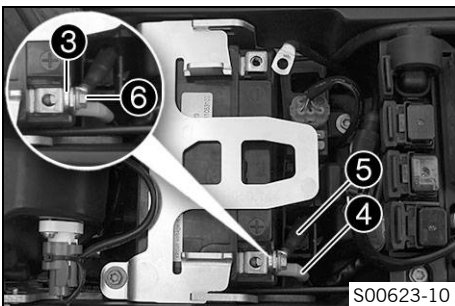

- Position washer ❸, positive cable ❷, and ABS connection cable ❹.
- Mount and tighten screw ❸.

Guideline

Remaining screws, chassis	M6	10 Nm (7.4 lbf ft)
---------------------------	----	--------------------

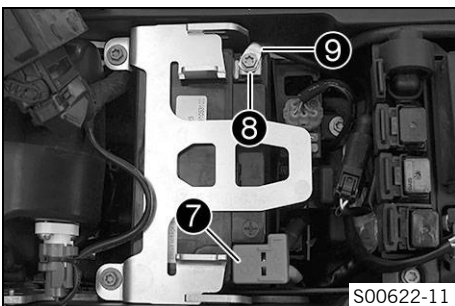

- Position positive terminal cover ❷.
- Position washer ❸ and negative cable ❹ and mount and tighten the screw.

Guideline

Remaining screws, chassis	M6	10 Nm (7.4 lbf ft)
---------------------------	----	--------------------

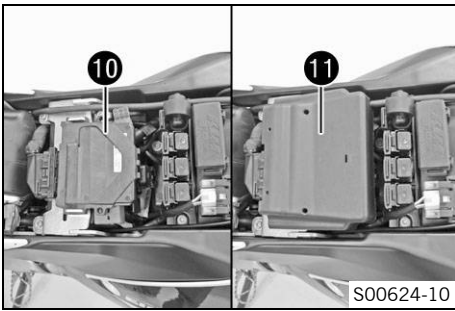

- Position the engine electronics control unit 10.
- Mount battery cover 11.

Finishing work

- Mount the seat. (☛ p. 6)
- Set the clock. (☛ p. 12)

3.6 Opening the filler cap

Danger
Fire hazard Fuel is highly flammable.

- Never refuel the vehicle near open flames or burning cigarettes, and always switch off the engine first. Be careful that no fuel is spilt, especially on hot vehicle components. Clean up spilt fuel immediately.
- The fuel in the fuel tank expands when warm and may emerge if overfilled. Follow the instructions on refueling.

Warning
Danger of poisoning Fuel is poisonous and a health hazard.

- Fuel must not come into contact with the skin, eyes, or clothing. Do not breathe in the fuel vapors. If contact occurs with the eyes, rinse with water immediately and contact a physician. Immediately clean contaminated areas on the skin with soap and water. If fuel is swallowed, contact a physician immediately. Change clothing that has been contaminated with fuel. Store fuel properly in a suitable canister and keep away from children.

Warning
Environmental hazard Improper handling of fuel is a danger to the environment.

- Do not allow fuel to get into the ground water, the ground, or the sewage system.

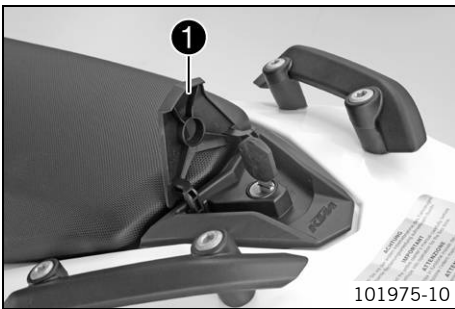

- Lift cover 1 of filler cap and insert the ignition key.
- Turn the ignition key 90° counterclockwise and remove the filler cap.

Info
 The filler cap has a fuel tank breather.

3.7 Closing filler cap



- Put the filler cap back on and turn the ignition key 90° clockwise.
- Remove the ignition key and fold down the cover.

3.8 Removing rear fairing

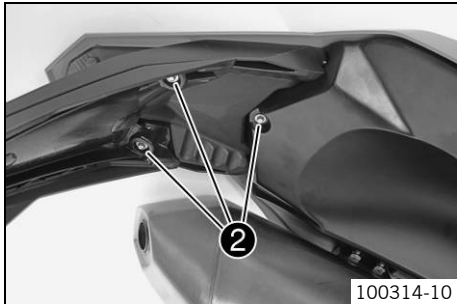
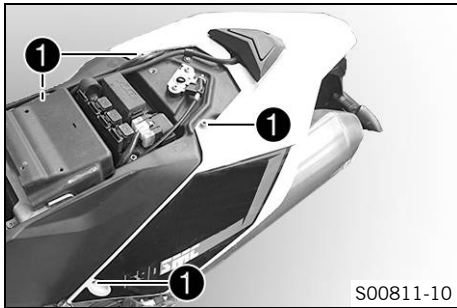

Preparatory work

- Remove the seat. (☞ p. 6)

Main work

- Remove screws ①.
- Remove screws ②.
- Open the filler cap. (☞ p. 9)
- Take off the rear fairing.
- Close the filler cap. (☞ p. 9)

3.9 Fitting rear fairing

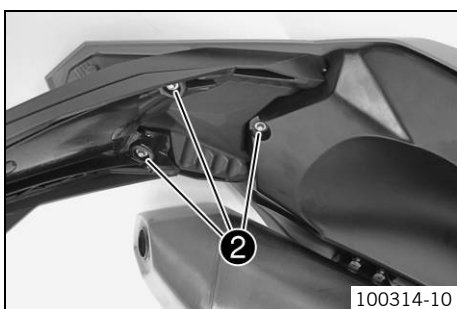

- Position the license plate holder and cable harness.
- Open the filler cap. (☞ p. 9)
- Position the rear fairing and grab handles ① as shown in the figure. Fit and slightly tighten the screws of the grab handles.
- Close the filler cap. (☞ p. 9)
- Fit and tighten the screws on the rear fairing.

Guideline

Remaining screws, chassis	M6	10 Nm (7.4 lbf ft)
---------------------------	----	--------------------

- Mount and tighten screws ②.
- Tighten the screws of the grab handles.

Guideline

Screw, handrail	M8	20 Nm (14.8 lbf ft)
-----------------	----	---------------------

- Mount the seat. (☞ p. 6)

3.10 Mounting rear footrest bracket



Info

The operations are the same for the left and right sides.

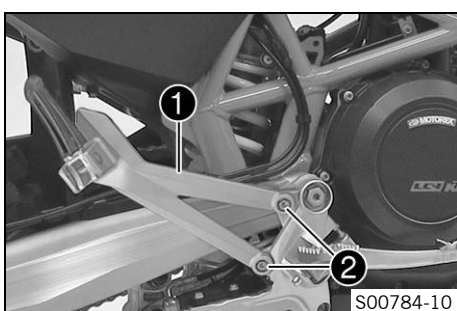

- Position the footrest bracket ①. Mount and tighten screws ②.

Guideline

Screw, rear footrest bracket	M8x16	25 Nm (18.4 lbf ft)
------------------------------	-------	---------------------

3.11 Mounting heel protector



Info

The operations are the same for the left and right sides.

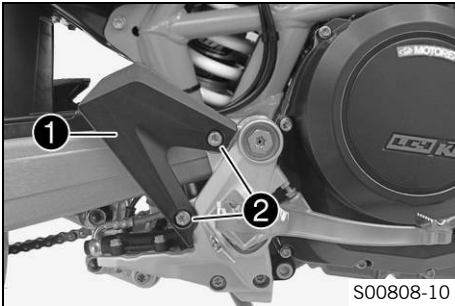

Warning

Forfeiture of homologation and insurance cover The vehicle is homologated as 2-seater. If the heel protector is fitted instead of the footrest bracket, the vehicle no longer conforms to the homologation and must not be operated in this form without alterations to the registration papers.

- Set up and operate the vehicle as a 2-seater or have changes made to the registration papers.

- Position the heel protector ①. Mount and tighten screws ②.

Guideline

Screw, heel protector	M8x12	5 Nm (3.7 lbf ft)	Loctite® 243™
-----------------------	-------	----------------------	---------------

3.12 Refueling



Danger

Fire hazard Fuel is highly flammable.

- Never refuel the vehicle near open flames or burning cigarettes, and always switch off the engine first. Be careful that no fuel is spilt, especially on hot vehicle components. Clean up spilt fuel immediately.
- The fuel in the fuel tank expands when warm and may emerge if overfilled. Follow the instructions on refueling.



Warning

Danger of poisoning Fuel is poisonous and a health hazard.

- Fuel must not come into contact with the skin, eyes, or clothing. Do not breathe in the fuel vapors. If contact occurs with the eyes, rinse with water immediately and contact a physician. Immediately clean contaminated areas on the skin with soap and water. If fuel is swallowed, contact a physician immediately. Change clothing that is contaminated with fuel.

Note

Material damage Premature clogging of the fuel filter.

- In some countries and regions, the available fuel quality and cleanliness may not be sufficient. This will result in problems with the fuel system.
- Only refuel with clean fuel that meets the specified standards.



Warning

Environmental hazard Improper handling of fuel is a danger to the environment.

- Do not allow fuel to get into the ground water, the ground, or the sewage system.

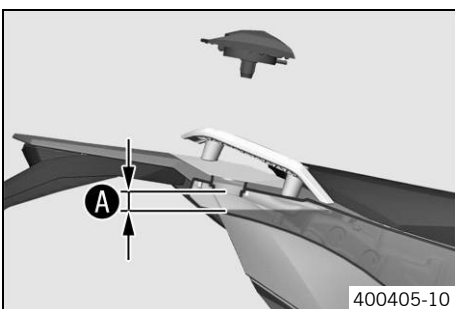

- Switch off the engine.
- Open the filler cap. (☛ p. 9)
- Fill the fuel tank with fuel up to measurement A.

Guideline

Measurement A	20 mm (0.79 in)	
Total fuel tank capacity, approx.	12 l (3.2 US gal)	Super unleaded (ROZ 95/RON 95/PON 91) (☛ p. 15)

- Close the filler cap. (☛ p. 9)

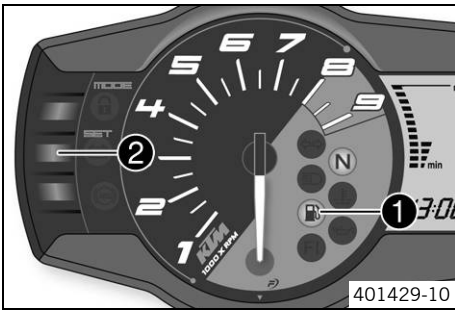

- Press the **SET** button **2** for two seconds.
- ✓ The fuel level warning lamp **1** switches off. **TRIP F** is set to **0.0** and the display returns to the previous display mode.

i Info
If you do not press the **SET** button **2**, the reset takes place automatically after approx. three minutes.

3.13 Setting the clock

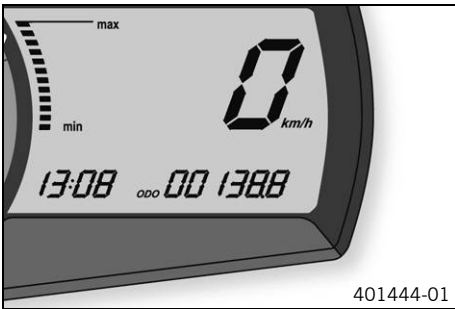

Condition

The motorcycle is stationary.

- Switch on the ignition by turning the ignition key to position **ON** \odot .
- Press the **MODE** button repeatedly until the **ODO** mode is active.
- Keep the **MODE** button and the **SET** button pressed simultaneously.
- ✓ The time display begins to flash.
- Press the **MODE** button to set the hour.
- Press the **SET** button to set the minute.
- Keep the **MODE** button and the **SET** button pressed simultaneously.
- ✓ The time is set.

3.14 Setting kilometers or miles

i Info
If you change the unit, the value **ODO** is retained and converted accordingly. Making the setting according to the country.

Condition

The motorcycle is stationary.

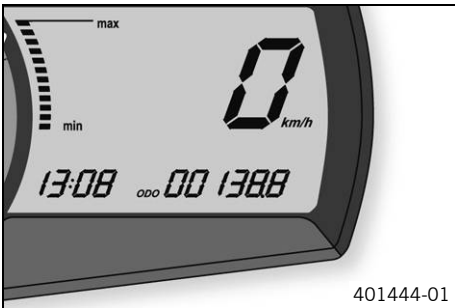

- Switch on the ignition by turning the ignition key to position **ON** \odot .
- Press the **MODE** button repeatedly until the **ODO** mode is active.
- Keep the **MODE** button pressed until the display mode changes from **km/h** to **mph** or from **mph** to **km/h**.

4.1 Chassis tightening torques

Screw, chain guard	EJOT	2 Nm (1.5 lbf ft)	–
Screw, combination instrument	EJOT	1 Nm (0.7 lbf ft)	–
Screw, license plate holder, bottom	EJOT	3 Nm (2.2 lbf ft)	–
Screw, side cover on spoiler	EJOT	1 Nm (0.7 lbf ft)	–
Screw, side stand switch	EJOT	2 Nm (1.5 lbf ft)	–
Screw, SLS valve	EJOT	2 Nm (1.5 lbf ft)	–
Fitting, side stand switch	M4	2 Nm (1.5 lbf ft)	–
Spoke nipple, front wheel	M4.5	4 Nm (3 lbf ft)	–
Spoke nipple, rear wheel	M4.5	4 Nm (3 lbf ft)	–
Bolt, foot brake lever stub	M5	6 Nm (4.4 lbf ft)	Loctite® 243™
Remaining nuts, chassis	M5	4 Nm (3 lbf ft)	–
Remaining screws, chassis	M5	4 Nm (3 lbf ft)	–
Screw, brake line holder on swingarm	M5	4 Nm (3 lbf ft)	–
Screw, cable on starter motor	M5	3 Nm (2.2 lbf ft)	–
Screw, combination switch, left	M5	3.5 Nm (2.58 lbf ft)	–
Screw, electrical holder	M5	3 Nm (2.2 lbf ft)	–
Screw, exhaust heat shield	M5	8 Nm (5.9 lbf ft)	Loctite® 243™
Screw, fuel hose clamp on fuel tank	M5	5 Nm (3.7 lbf ft)	–
Screw, fuel level sensor	M5	3 Nm (2.2 lbf ft)	–
Screw, fuel pump	M5	4 Nm (3 lbf ft)	–
Screw, fuel tank closure flange	M5	2.5 Nm (1.84 lbf ft)	–
Screw, headlight mask	M5	5 Nm (3.7 lbf ft)	–
Screw, pressure regulator	M5	4 Nm (3 lbf ft)	–
Screw, throttle grip	M5	3.5 Nm (2.58 lbf ft)	–
Remaining nuts, chassis	M6	10 Nm (7.4 lbf ft)	–
Remaining screws on fuel tank	M6	5 Nm (3.7 lbf ft)	–
Remaining screws, chassis	M6	10 Nm (7.4 lbf ft)	–
Screw connection, foot brake cylinder	M6	10 Nm (7.4 lbf ft)	–
Screw, ABS control unit	M6	5 Nm (3.7 lbf ft)	–
Screw, air filter box top	M6	2 Nm (1.5 lbf ft)	–
Screw, ball joint of push rod on foot brake cylinder	M6	10 Nm (7.4 lbf ft)	Loctite® 243™
Screw, brake assembly	M6	5 Nm (3.7 lbf ft)	–
Screw, brake fluid reservoir of rear brake	M6	5 Nm (3.7 lbf ft)	–
Screw, chain guard	M6	2 Nm (1.5 lbf ft)	Loctite® 243™
Screw, chain guide	M6	8 Nm (5.9 lbf ft)	–
Screw, chain sliding guard	M6	8 Nm (5.9 lbf ft)	Loctite® 243™
Screw, clutch assembly	M6	5 Nm (3.7 lbf ft)	–
Screw, fan hood	M6	4 Nm (3 lbf ft)	–
Screw, front brake disc	M6	14 Nm (10.3 lbf ft)	Loctite® 243™
Screw, ignition lock	M6	10 Nm (7.4 lbf ft)	Loctite® 243™
Screw, lower radiator bracket	M6	8 Nm (5.9 lbf ft)	–
Screw, magnetic holder on side stand	M6	6 Nm (4.4 lbf ft)	Loctite® 243™
Screw, radiator guard	M6	8 Nm (5.9 lbf ft)	–
Screw, rear brake disc	M6	14 Nm (10.3 lbf ft)	Loctite® 243™
Screw, seat lock	M6	5 Nm (3.7 lbf ft)	–
Screw, side cover	M6	5 Nm (3.7 lbf ft)	–
Screw, upper radiator bracket	M6	10 Nm (7.4 lbf ft)	–
Screw, voltage regulator	M6	8 Nm (5.9 lbf ft)	–
Screw, wheel speed sensor	M6	6 Nm (4.4 lbf ft)	–

Nut, rear sprocket screw	M8	35 Nm (25.8 lbf ft)	Loctite® 2701™
Remaining nuts, chassis	M8	25 Nm (18.4 lbf ft)	–
Remaining screws, chassis	M8	25 Nm (18.4 lbf ft)	–
Screw, bottom triple clamp	M8	12 Nm (8.9 lbf ft)	–
Screw, chain sliding piece	M8	15 Nm (11.1 lbf ft)	–
Screw, connection lever on frame	M8	30 Nm (22.1 lbf ft)	Loctite® 243™
Screw, foot brake lever	M8	25 Nm (18.4 lbf ft)	Loctite® 243™
Screw, fork stub	M8	15 Nm (11.1 lbf ft)	–
Screw, front footrest bracket	M8	25 Nm (18.4 lbf ft)	–
Screw, fuel tank bracket	M8	15 Nm (11.1 lbf ft)	–
Screw, fuel tank, bottom	M8	25 Nm (18.4 lbf ft)	Loctite® 243™
Screw, fuel tank, top	M8	25 Nm (18.4 lbf ft)	Loctite® 243™
Screw, handlebar clamp	M8	20 Nm (14.8 lbf ft)	–
Screw, handrail	M8	20 Nm (14.8 lbf ft)	–
Screw, heel protector	M8x12	5 Nm (3.7 lbf ft)	Loctite® 243™
Screw, license plate holder, top	M8	20 Nm (14.8 lbf ft)	–
Screw, main silencer clamp	M8	12 Nm (8.9 lbf ft)	Copper paste
Screw, main silencer holder	M8	25 Nm (18.4 lbf ft)	–
Screw, main silencer holder on fuel tank	M8	25 Nm (18.4 lbf ft)	–
Screw, rear footrest bracket	M8x16	25 Nm (18.4 lbf ft)	–
Screw, side stand bracket	M8	25 Nm (18.4 lbf ft)	Loctite® 243™
Screw, spring holder on side stand bracket	M8	25 Nm (18.4 lbf ft)	Loctite® 243™
Screw, steering stem	M8	20 Nm (14.8 lbf ft)	–
Screw, top triple clamp	M8	17 Nm (12.5 lbf ft)	–
Engine carrying screw	M10	45 Nm (33.2 lbf ft)	Loctite® 243™
Remaining nuts, chassis	M10	45 Nm (33.2 lbf ft)	–
Remaining screws, chassis	M10	45 Nm (33.2 lbf ft)	–
Screw, bottom shock absorber	M10	45 Nm (33.2 lbf ft)	Loctite® 243™
Screw, engine bearer on frame	M10	45 Nm (33.2 lbf ft)	–
Screw, handlebar support	M10	40 Nm (29.5 lbf ft)	Loctite® 243™
Screw, side stand	M10	35 Nm (25.8 lbf ft)	Loctite® 243™
Screw, top shock absorber	M10	45 Nm (33.2 lbf ft)	Loctite® 243™
Banjo bolt, brake line	M10x1	20 Nm (14.8 lbf ft)	–
Screw, front brake caliper	M10x1.25	45 Nm (33.2 lbf ft)	Loctite® 243™
Screw, swingarm pivot	M12	80 Nm (59 lbf ft)	–
Lambda sensor	M12x1.25	25 Nm (18.4 lbf ft)	Copper paste
Nut, linkage lever on swingarm	M14x1.5	100 Nm (73.8 lbf ft)	–
Nut, linkage lever to rocker arm	M14x1.5	100 Nm (73.8 lbf ft)	–
Screw, bottom steering head	M20x1.5	60 Nm (44.3 lbf ft)	Loctite® 243™
Screw, top steering head	M20x1.5	12 Nm (8.9 lbf ft)	–
Screw, front wheel spindle	M24x1.5	45 Nm (33.2 lbf ft)	–
Nut, rear wheel spindle	M25x1.5	90 Nm (66.4 lbf ft)	–

Super unleaded (ROZ 95/RON 95/PON 91)

Standard/classification

- DIN EN 228 (ROZ 95/RON 95/PON 91)

Guideline

- Only use unleaded super fuel that matches or is equivalent to the specified fuel grade.
- Fuel with an ethanol content of up to 10 % (E10 fuel) is safe to use.



Info

Do **not** use fuel containing methanol (e. g. M15, M85, M100) or more than 10 % ethanol (e. g. E15, E25, E85, E100).



3213316en

03/2015

