



**125 Duke EU
200 Duke EU
200 Duke AR
200 Duke ASIA
200 Duke BR
200 Duke CN
200 Duke 2016 CO
200 Duke MY**

Art. no. 3213323en

The work described in these setup instructions must be performed before the vehicle is delivered to the customer.

Read the setup instructions in their entirety before beginning work.

Print out the current **PDI** form found on the **KTM Dealer.net**.

These setup instructions were written to correspond to the latest state of this series. We reserve the right to make changes in the interest of technical advancement without at the same time updating this manual.

We shall not provide a description of general workshop methods. Likewise, safety rules that apply in a workshop are not specified here. It is assumed that the work will be performed by a fully trained mechanic.

All specifications are non-binding. KTM Sportmotorcycle GmbH specifically reserves the right to modify or delete technical specifications, prices, colors, forms, materials, services, designs, equipment, etc., without prior notice and without specifying reasons, to adapt these to local conditions, as well as to stop production of a particular model without prior notice. KTM accepts no liability for delivery options, deviations from illustrations and descriptions, misprints, and other errors. The models portrayed partly contain special equipment that does not belong to the regular scope of supply.

© 2015 KTM Sportmotorcycle GmbH, Mattighofen Austria

All rights reserved

Reproduction, even in part, as well as copying of all kinds, is permitted only with the express written permission of the copyright owner.



ISO 9001(12 100 6061)

According to the international quality management standard ISO 9001, KTM uses quality assurance processes that lead to the maximum possible quality of the products.

Issued by: TÜV Management Service

REG.NO. 12 100 6061

KTM Sportmotorcycle GmbH
5230 Mattighofen, Austria

1.1 Symbols used

The meaning of specific symbols is described below.



Indicates an expected reaction (e.g. of a work step or a function).



Indicates an unexpected reaction (e.g. of a work step or a function).



Indicates a page reference (more information is provided on the specified page).



Indicates information with more details or tips.



Indicates the result of a testing step.



Denotes a voltage measurement.



Denotes a current measurement.



Denotes a resistance measurement.

1.2 Formats used

The typographical formats used in this document are explained below.

Proprietary name	Identifies a proprietary name.
Name®	Identifies a protected name.
Brand™	Identifies a trademark.
<u>Underlined terms</u>	Refer to technical details of the vehicle or indicate technical terms, which are explained in the glossary.

2.1 Unpacking and setting up the vehicle



S00786-10

- Remove straps and box.



S00790-10

- Remove the adhesive tape in the upper area of the motorcycle.

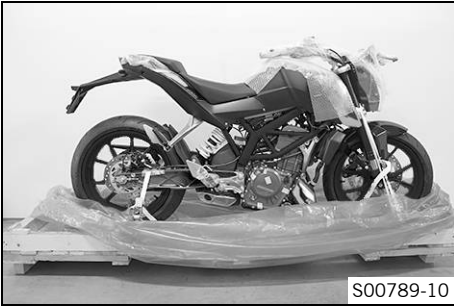

S00789-10

- Roll down the film at the sides.

i Info

To avoid damaging the motorcycle during unpacking, leave the other films on the vehicle until you have finished work on the vehicle.

- Remove the separate enclosure and unpack it. Check the separate enclosure for completeness.
- Check the vehicle for transport damage.

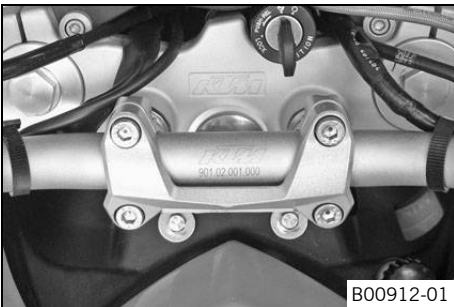

B00912-01

- Position the handlebar.
 - ✓ The lettering on the handlebar is in the middle of the handlebar clamp.
- Position the handlebar clamps. Mount and tighten the screws evenly.

Guideline

Screw, handlebar clamp	M8	21 Nm (15.5 lbf ft)	Loctite® 243™
------------------------	----	------------------------	---------------



B00913-01

- Mount and tighten the rear mirror on both sides.
- Position all controls in their exact positions on the handlebar. Tighten all screws.



700217-01

- Mount the reflector.
- Remove the protective plastic.
- Carefully loosen and remove the tension belt over the swingarm.

i Info

An assistant prevents the motorcycle from falling over.

- Carefully loosen and remove the tension belts around the lower triple clamp.
 - ✓ The vehicle is released at the front.

- Take the vehicle off the pallet.
-

**Warning**

Risk of injury Battery acid and battery gases cause serious chemical burns.

- Keep batteries out of the reach of children.
 - Wear suitable protective clothing and goggles.
 - Avoid contact with battery acid and battery gases.
 - Keep sparks and open flames away from the battery. Only charge in well-ventilated rooms.
 - In the event of skin contact, rinse with large amounts of water. If battery acid gets in the eyes, rinse with water for at least 15 minutes and contact a physician.
-

- Fill the battery.
-

**Info**

Read the notes in the battery package.

- Recharge the battery. (☛ p. 6)
- Install the battery. (☛ p. 7)
- Refuel. (☛ p. 9)
- Print out the current **PDI** form found on the **KTM Dealer.net** and perform the pre-delivery inspection.
- Set kilometers or miles. (☛ p. 9)
- Set the clock. (☛ p. 9)

3.1 Removing the passenger seat



- Insert the ignition key in seat lock **1** and turn it clockwise.
- Raise the rear of the seat, push it towards the rear, and remove it upwards.
- Remove the ignition key from the seat lock.

3.2 Mounting the passenger seat

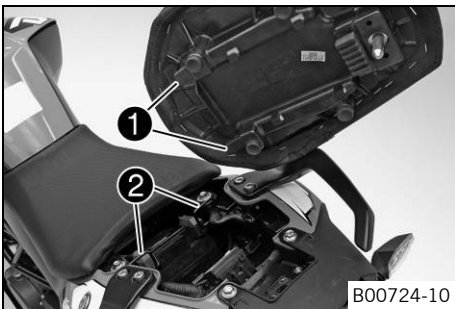

- Attach hooks **1** on the passenger seat to brackets **2** on the subframe, and lower it at the rear while pushing forward.
- Press down the passenger seat until it clicks into place.



Warning

Danger of accidents The passenger seat can come loose from the anchoring if it is not mounted correctly.

- After mounting the passenger seat, check that it is locked correctly by pulling up.

- Finally, check that the passenger seat is correctly mounted.

3.3 Removing the seat

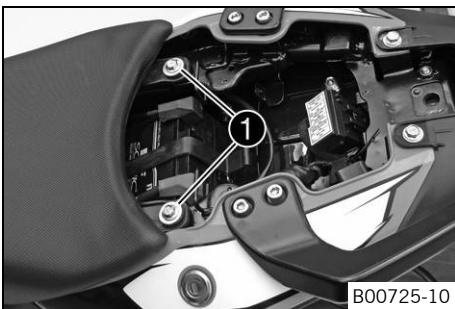

Preparatory work

- Remove the passenger seat. (☛ p. 5)

Main work

- Remove screws **1**.
- Raise the rear of the seat, pull it towards the rear, and remove it upwards.

3.4 Mounting the seat

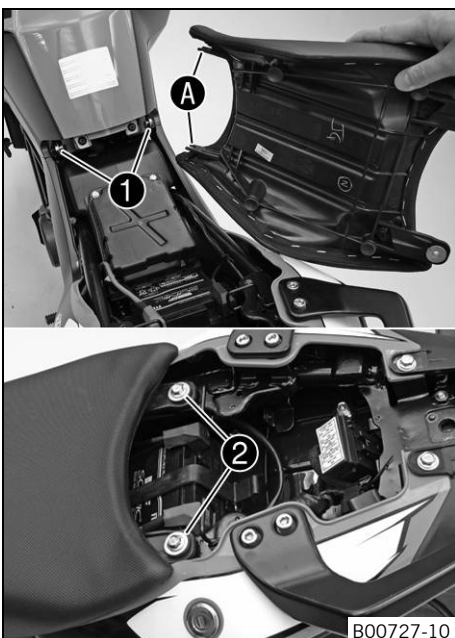

Main work

- Attach seat recesses **A** at screws **1** and lower at the rear.
- Mount and tighten screws **2**.

Guideline

Screw, seat	M6	10 Nm (7.4 lbf ft)
-------------	----	--------------------

Finishing work

- Mount the passenger seat. (☛ p. 5)

3.5 Removing the battery



Warning

Risk of injury Battery acid and battery gases cause serious chemical burns.

- Keep batteries out of the reach of children.
- Wear suitable protective clothing and goggles.
- Avoid contact with battery acid and battery gases.
- Keep sparks and open flames away from the battery. Only charge in well-ventilated rooms.
- In the event of skin contact, rinse with large amounts of water. If battery acid gets in the eyes, rinse with water for at least 15 minutes and contact a physician.

Preparatory work

- Remove the passenger seat. (☛ p. 5)
- Remove the seat. (☛ p. 5)

Main work

- Pull back the negative terminal cover ❶.
- Disconnect negative cable ❷ from the battery.

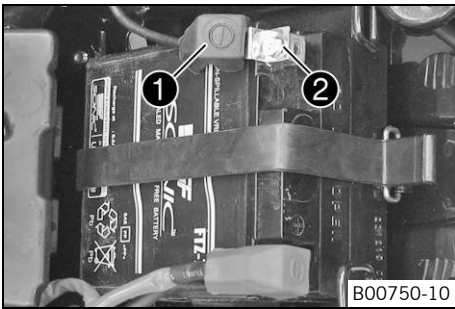

- Pull back the positive terminal cover ❸.
- Disconnect positive cable ❹ from the battery.
- Detach rubber band ❺.
- Pull the battery up and out of the battery holder.

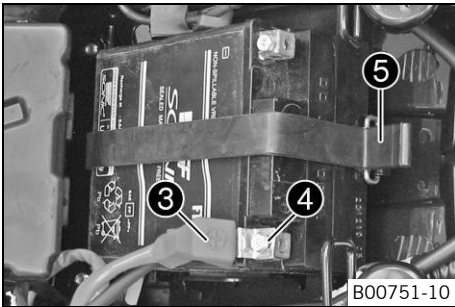

Info

Never operate the motorcycle with a discharged battery or without a battery. In both cases, electrical components and safety devices can be damaged. The vehicle is therefore no longer roadworthy.

3.6 Recharging the battery



Warning

Risk of injury Battery acid and battery gases cause serious chemical burns.

- Keep batteries out of the reach of children.
- Wear suitable protective clothing and goggles.
- Avoid contact with battery acid and battery gases.
- Keep sparks and open flames away from the battery. Only charge in well-ventilated rooms.
- In the event of skin contact, rinse with large amounts of water. If battery acid gets in the eyes, rinse with water for at least 15 minutes and contact a physician.



Warning

Environmental hazard The battery contains elements that are harmful to the environment.

- Do not dispose of batteries with the household waste. Dispose of a defective battery in an environmentally friendly manner. Give the battery to your authorized KTM dealer or dispose of it at a collection point for used batteries.

i Info

Even when there is no load on the battery, it discharges steadily.
 The charging level and the method of charging are very important for the service life of the battery.
 Rapid recharging with a high charging current shortens the battery's service life.
 If the charging current, charging voltage, or charging time is exceeded, electrolyte escapes through the safety valves. This reduces the battery capacity.
 If the battery is depleted from starting the vehicle repeatedly, the battery must be charged immediately.
 If the battery is left in a discharged state for an extended period, it will become over-discharged and sulfate, destroying the battery.
 The battery is maintenance-free. The acid level does not have to be checked.

Preparatory work

- Switch off all power consumers and switch off the engine.
- Remove the passenger seat. (☛ p. 5)
- Remove the seat. (☛ p. 5)
- Disconnect the negative cable of the battery to avoid damage to the onboard electronics.

Main work

- Connect the battery charger to the battery. Switch on the battery charger.

Battery charger (58429074000)

You can also use the battery charger to test rest potential and start potential of the battery, and to test the alternator. With this device, you cannot overcharge the battery.

i Info

Never remove lid **1**.
 Charge the battery with a maximum of 10% of the capacity specified on battery housing **2**.

- Switch off the battery charger after charging and disconnect from the battery.

Guideline

The charge current, charge voltage and charge time must not be exceeded.

Charge the battery regularly when the motorcycle is not in use	3 months
--	----------

- Position the negative cable and mount and tighten the screw.
- Position the negative terminal cover.

Finishing work

- Mount the seat. (☛ p. 5)
- Mount the passenger seat. (☛ p. 5)
- Set the clock. (☛ p. 9)

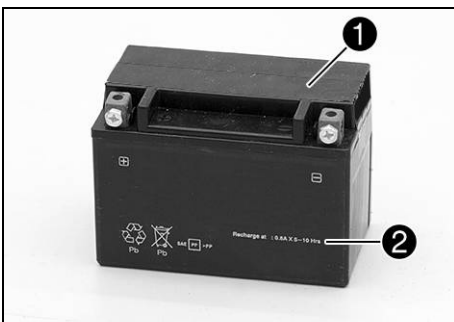

3.7 Installing the battery

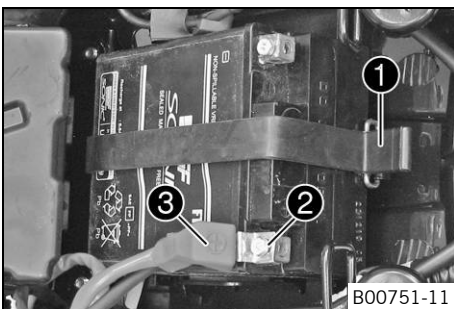

Main work

- Position the battery in the battery holder.

Guideline

The battery terminals must be facing upward.

Alternative 1

(125 Duke)
Battery (FTZ-7)

Alternative 1

(200 Duke)
Battery (FTZ-9)

- Attach rubber band **1**.
- Position the positive cable **2** and mount and tighten the screw.
- Position positive terminal cover **3**.

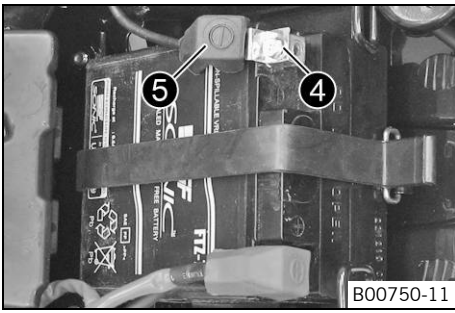

- Position the negative cable ④ and mount and tighten the screw.
- Position the negative terminal cover ⑤.

Finishing work

- Mount the seat. (☛ p. 5)
- Mount the passenger seat. (☛ p. 5)
- Set the clock. (☛ p. 9)

3.8 Opening the filler cap



Danger

Fire hazard Fuel is highly flammable.

- Never refuel the vehicle near open flames or burning cigarettes, and always switch off the engine first. Be careful that no fuel is spilt, especially on hot vehicle components. Clean up spilt fuel immediately.
- The fuel in the fuel tank expands when warm and may emerge if overfilled. Follow the instructions on refueling.



Warning

Danger of poisoning Fuel is poisonous and a health hazard.

- Fuel must not come into contact with the skin, eyes, or clothing. Do not breathe in the fuel vapors. If contact occurs with the eyes, rinse with water immediately and contact a physician. Immediately clean contaminated areas on the skin with soap and water. If fuel is swallowed, contact a physician immediately. Change clothing that has been contaminated with fuel. Store fuel properly in a suitable canister and keep away from children.



Warning

Environmental hazard Improper handling of fuel is a danger to the environment.

- Do not allow fuel to get into the ground water, the ground, or the sewage system.

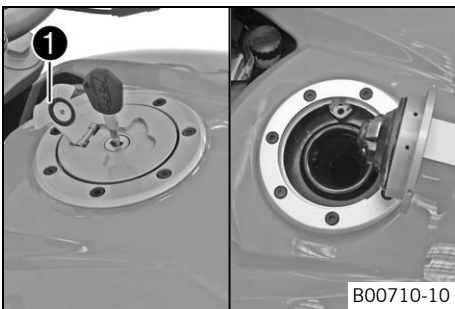

- Lift the cover ① of the filler cap and insert the ignition key in the lock.

Note

Danger of damage Ignition key breakage.

- To take pressure off of the ignition key, push down on the filler cap. Damaged ignition keys must be replaced.

- Turn the ignition key 90° clockwise.
- Open the filler cap.
- Remove the ignition key.

3.9 Closing the filler cap

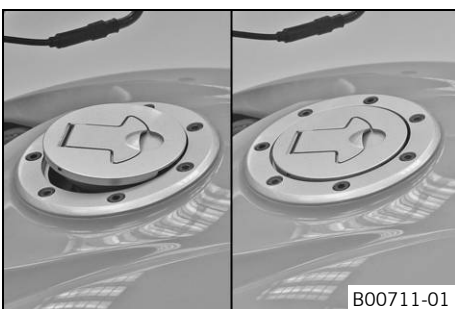

Warning

Fire hazard Fuel is highly flammable, poisonous and harmful to your health.

- After closing the filler cap, ensure that it is locked properly. Change clothing that has been contaminated with fuel. Immediately clean contaminated areas on the skin with soap and water.

- Close the filler cap.
- Push down the filler cap until the lock engages.

3.10 Refueling

Danger
Fire hazard Fuel is highly flammable.

- Never refuel the vehicle near open flames or burning cigarettes, and always switch off the engine first. Be careful that no fuel is spilt, especially on hot vehicle components. Clean up spilt fuel immediately.
- The fuel in the fuel tank expands when warm and may emerge if overfilled. Follow the instructions on refueling.

Warning
Danger of poisoning Fuel is poisonous and a health hazard.

- Fuel must not come into contact with the skin, eyes, or clothing. Do not breathe in the fuel vapors. If contact occurs with the eyes, rinse with water immediately and contact a physician. Immediately clean contaminated areas on the skin with soap and water. If fuel is swallowed, contact a physician immediately. Change clothing that is contaminated with fuel.

Note
Material damage Premature clogging of the fuel filter.

- In some countries and regions, the available fuel quality and cleanliness may not be sufficient. This will result in problems with the fuel system.
- Only refuel with clean fuel that meets the specified standards.

Warning
Environmental hazard Improper handling of fuel is a danger to the environment.

- Do not allow fuel to get into the ground water, the ground, or the sewage system.

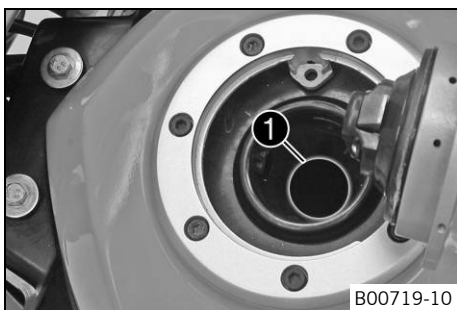

B00719-10

- Switch off the engine.
- Open the filler cap. (☛ p. 8)
- Fill the fuel tank with fuel up to the lower edge **1** of the fuel filler.

Total fuel tank capacity, approx.	11 l (2.9 US gal)	Super unleaded (ROZ 95/RON 95/PON 91) (☛ p. 14)
-----------------------------------	-------------------	---

- Close the filler cap. (☛ p. 8)

3.11 Setting the time



401303-01

Condition
 The ignition is on.
 The motorcycle is stationary.

- Press the **MODE** button briefly and repeatedly until **ODO** appears on the display.
- Press the **MODE** and **SET** buttons for 5 - 10 seconds.
 - ✓ The time display begins to flash.
- Set the hours display using the **MODE** button.
- Set the minutes display using the **SET** button.
- Press the **MODE** and **SET** buttons for 5 - 10 seconds.
 - ✓ The time is set.

3.12 Setting kilometers or miles

Info
 Make the country-specific setting.

Condition
 The ignition is on.
 The motorcycle is stationary.

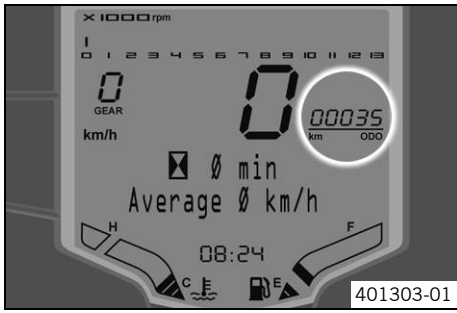

- Press the **MODE** button briefly and repeatedly until **ODO** appears on the display.
- Press the **MODE** button for 5 - 10 seconds.
- ✓ The display changes from **km/h** to **mph** or from **mph** to **km/h**.

4.1 Chassis tightening torques

Exhaust clamp	-	19 Nm (14 lbf ft)	-
Helmet holder screw	EJOT PT®	3 Nm (2.2 lbf ft)	-
Screw, chain guard	EJOT PT®	4 Nm (3 lbf ft)	-
Screw, headlight	EJOT PT®	4 Nm (3 lbf ft)	-
Remaining screws, chassis	M4	4 Nm (3 lbf ft)	-
Screw, EFI control unit	M4	5 Nm (3.7 lbf ft)	-
Screw, license plate lamp	M4	2 Nm (1.5 lbf ft)	-
Screw, trim, subframe, bottom	M4	5 Nm (3.7 lbf ft)	-
Remaining nuts, chassis	M5	5 Nm (3.7 lbf ft)	-
Remaining screws, chassis	M5	5 Nm (3.7 lbf ft)	-
Screw, ABS hose clamp (125 Duke, 200 Duke)	M5	6 Nm (4.4 lbf ft)	-
Screw, brake line holder, rear	M5	7 Nm (5.2 lbf ft)	Loctite® 243™
Screw, chain guard	M5	4 Nm (3 lbf ft)	Loctite® 243™
Screw, fuel pump	M5	5 Nm (3.7 lbf ft)	-
Screw, fuel tank closure flange	M5	5 Nm (3.7 lbf ft)	-
Screw, fuel tank cover	M5	4 Nm (3 lbf ft)	-
Screw, fuel tank trim	M5	5 Nm (3.7 lbf ft)	-
Screw, license plate holder	M5	11 Nm (8.1 lbf ft)	-
Screw, rollover sensor	M5	6 Nm (4.4 lbf ft)	Loctite® 243™
Screw, side stand switch	M5	5 Nm (3.7 lbf ft)	Loctite® 243™
Screw, spoiler	M5	5 Nm (3.7 lbf ft)	-
Screw, subframe cover, bottom	M5	5 Nm (3.7 lbf ft)	-
Screw, tail end lower part	M5	6 Nm (4.4 lbf ft)	-
Screw, tail light	M5	5 Nm (3.7 lbf ft)	-
Screw, windshield	M5	3 Nm (2.2 lbf ft)	-
Clutch cable retaining bracket screw	M6	6 Nm (4.4 lbf ft)	-
Damping rubber frame screw	M6	7 Nm (5.2 lbf ft)	-
Nut, foot brake lever adjustment	M6	9 Nm (6.6 lbf ft)	-
Nut, radiator	M6	5 Nm (3.7 lbf ft)	-
Remaining nuts, chassis	M6	10 Nm (7.4 lbf ft)	-
Remaining screws, chassis	M6	10 Nm (7.4 lbf ft)	-
Screw, ABS module (125 Duke, 200 Duke)	M6	7 Nm (5.2 lbf ft)	-
Screw, air filter box	M6	6 Nm (4.4 lbf ft)	-
Screw, air filter box lid	M6	3 Nm (2.2 lbf ft)	-
Screw, brake fluid reservoir of rear brake	M6	9 Nm (6.6 lbf ft)	-
Screw, cable holder, side stand switch	M6	9 Nm (6.6 lbf ft)	Loctite® 243™
Screw, chain sliding guard	M6	9 Nm (6.6 lbf ft)	-
Screw, compensating tank	M6	13 Nm (9.6 lbf ft)	-
Screw, foot brake cylinder	M6	9 Nm (6.6 lbf ft)	Loctite® 243™
Screw, front fender	M6	11 Nm (8.1 lbf ft)	-
Screw, front seat fixing	M6	6 Nm (4.4 lbf ft)	-
Screw, front spoiler	M6	9 Nm (6.6 lbf ft)	-
Screw, fuel tank	M6	13 Nm (9.6 lbf ft)	-
Screw, headlight holder	M6	11 Nm (8.1 lbf ft)	-
Screw, headlight mask	M6	11 Nm (8.1 lbf ft)	Loctite® 243™
Screw, ignition coil	M6	9 Nm (6.6 lbf ft)	-
Screw, license plate holder	M6	12 Nm (8.9 lbf ft)	Loctite® 243™
Screw, lower rear panel	M6	5 Nm (3.7 lbf ft)	-

Screw, magnetic holder on side stand	M6	5 Nm (3.7 lbf ft)	Loctite® 243™
Screw, main silencer	M6	10 Nm (7.4 lbf ft)	–
Screw, radiator bracket	M6	6 Nm (4.4 lbf ft)	–
Screw, radiator holder	M6	9 Nm (6.6 lbf ft)	–
Screw, rear ABS sensor wheel (125 Duke, 200 Duke)	M6	8 Nm (5.9 lbf ft)	Loctite® 243™
Screw, rear splash protector	M6	9 Nm (6.6 lbf ft)	–
Screw, rollover sensor holder	M6	11 Nm (8.1 lbf ft)	–
Screw, seat	M6	10 Nm (7.4 lbf ft)	–
Screw, shift lever linkage	M6	11 Nm (8.1 lbf ft)	Loctite® 243™
Screw, tail end lower part, front	M6	11 Nm (8.1 lbf ft)	–
Screw, voltage regulator	M6	10 Nm (7.4 lbf ft)	–
Screw, voltage regulator holder	M6	11 Nm (8.1 lbf ft)	–
Screw, wheel speed sensor holder (125 Duke, 200 Duke)	M6	8 Nm (5.9 lbf ft)	–
Silent block retaining bracket screw	M6	7 Nm (5.2 lbf ft)	–
Fitting, engine mounting bracket	M8	48 Nm (35.4 lbf ft)	–
Nut, rear sprocket	M8	27 Nm (19.9 lbf ft)	Loctite® 243™
Remaining nuts, chassis	M8	25 Nm (18.4 lbf ft)	–
Remaining screws, chassis	M8	25 Nm (18.4 lbf ft)	–
Screw, bottom triple clamp	M8	15 Nm (11.1 lbf ft)	–
Screw, engine bearer on frame	M8	26 Nm (19.2 lbf ft)	–
Screw, foot brake lever	M8	16 Nm (11.8 lbf ft)	Loctite® 243™
Screw, fork stub	M8	15 Nm (11.1 lbf ft)	–
Screw, front brake disc	M8	30 Nm (22.1 lbf ft)	Loctite® 243™
Screw, front wheel spindle	M8	26 Nm (19.2 lbf ft)	–
Screw, handlebar clamp	M8	21 Nm (15.5 lbf ft)	Loctite® 243™
Screw, handrail	M8	32 Nm (23.6 lbf ft)	–
Screw, horn	M8	7 Nm (5.2 lbf ft)	–
Screw, main silencer	M8	24 Nm (17.7 lbf ft)	–
Screw, passenger footrest bracket	M8	26 Nm (19.2 lbf ft)	Loctite® 243™
Screw, rear brake disc	M8	30 Nm (22.1 lbf ft)	Loctite® 243™
Screw, shift lever	M8	16 Nm (11.8 lbf ft)	Loctite® 243™
Screw, top triple clamp	M8	11 Nm (8.1 lbf ft)	–
Screw, front brake caliper	M8x1	30 Nm (22.1 lbf ft)	Loctite® 204™
Banjo bolt, brake line	M10	24 Nm (17.7 lbf ft)	–
Fitting side stand	M10	35 Nm (25.8 lbf ft)	Loctite® 243™
Nut mirror image left	M10	16 Nm (11.8 lbf ft)	–
Remaining nuts, chassis	M10	45 Nm (33.2 lbf ft)	–
Remaining screws, chassis	M10	45 Nm (33.2 lbf ft)	–
Screw, engine bearer on engine	M10	47 Nm (34.7 lbf ft)	–
Fitting, bottom shock absorber	M10x1.25	45 Nm (33.2 lbf ft)	–
Fitting, handlebar support	M10x1.25	21 Nm (15.5 lbf ft)	–
Nut, mirror, right	M10LHx1.25	16 Nm (11.8 lbf ft)	–
Nut, turn signal	M10x1.25	6 Nm (4.4 lbf ft)	–
Screw, front footrest bracket	M10x1.25	47 Nm (34.7 lbf ft)	Loctite® 243™
Screw, front footrest bracket / engine bearer	M10x1.25	47 Nm (34.7 lbf ft)	–
Screw, side stand bracket	M10x1.25	25 Nm (18.4 lbf ft)	Loctite® 243™
Screw, top shock absorber	M10x1.25	51 Nm (37.6 lbf ft)	Loctite® 243™
Stud, rear sprocket	M10x1.25	50 Nm (36.9 lbf ft)	–
Nut, rear wheel spindle	M14x1.5	90 Nm (66.4 lbf ft)	–
Nut, swingarm pivot	M14x1.5	100 Nm (73.8 lbf ft)	–

Screw, top steering head	M16x1.5	53 Nm (39.1 lbf ft)	Loctite® 243™
Lambda sensor	M18x1.5	19 Nm (14 lbf ft)	–
Swingarm bearing adjusting ring	M22x1	Tighten and ensure that there is no play	–
Nut, steering head	M30x1	Step 1 55 Nm (40.6 lbf ft) 2nd stage (loosen, counter-clockwise) 2 turns Step 3 5 Nm (3.7 lbf ft)	–

Super unleaded (ROZ 95/RON 95/PON 91)

Standard/classification

- DIN EN 228 (ROZ 95/RON 95/PON 91)

Guideline

- Only use unleaded super fuel that matches or is equivalent to the specified fuel grade.
- Fuel with an ethanol content of up to 10 % (E10 fuel) is safe to use.



Info

Do **not** use fuel containing methanol (e. g. M15, M85, M100) or more than 10 % ethanol (e. g. E15, E25, E85, E100).



3213323en

03/2015

