

1050 Adventure

Art. no. 3213391en



KTM

DEAR KTM CUSTOMER

Congratulations on your decision to purchase a KTM motorcycle. You are now the owner of a state-of-the-art sports motorcycle that will give you enormous pleasure if you service and maintain it properly.

We hope you enjoy your new vehicle!

Please enter the serial numbers of your vehicle below.

Chassis number (☛ p. 22)	Dealer's stamp
Engine number (☛ p. 23)	
Key number (☛ p. 23)	

The Owner's Manual contained the latest information for this model series at the time of going to print. Minor differences due to developments in design cannot be ruled out completely.

All specifications are non-binding. KTM Sportmotorcycle GmbH specifically reserves the right to modify or delete technical specifications, prices, colors, forms, materials, services, designs, equipment, etc., without prior notice and without specifying reasons, to adapt these to local conditions, as well as to stop production of a particular model without prior notice. KTM accepts no liability for delivery options, deviations from illustrations and descriptions, misprints, and other errors. The models portrayed partly contain special equipment that does not belong to the regular scope of supply.

© 2015 KTM Sportmotorcycle GmbH, Mattighofen Austria
All rights reserved



3213391en

10/2015

DEAR KTM CUSTOMER

Reproduction, even in part, as well as copying of all kinds, is permitted only with the express written permission of the copyright owner.



ISO 9001(12 100 6061)

According to the international quality management standard ISO 9001, KTM uses quality assurance processes that lead to the maximum possible quality of the products.

Issued by: TÜV Management Service

REG.NO. 12 100 6061

KTM Sportmotorcycle GmbH
5230 Mattighofen, Austria

This document is valid for the following models:

1050 Adventure EU (F9903PC)

1050 Adventure AU (F9960PC)

1050 Adventure MY (F9989PC)

TABLE OF CONTENTS

1	MEANS OF REPRESENTATION	8	5.6	Shock absorber article number	24
	1.1 Symbols used	8	6	CONTROLS.....	25
	1.2 Formats used.....	9	6.1	Clutch lever	25
2	SAFETY ADVICE.....	10	6.2	Hand brake lever.....	25
	2.1 Use definition - intended use	10	6.3	Throttle grip	26
	2.2 Safety advice.....	10	6.4	Switches on the left side of the handlebar	26
	2.3 Degrees of risk and symbols	11	6.4.1	Combination switch.....	26
	2.4 Tampering warning.....	11	6.4.2	Light switch	27
	2.5 Safe operation	12	6.4.3	Hazard warning flasher switch.....	27
	2.6 Protective clothing	13	6.4.4	Menu switch.....	28
	2.7 Work rules	13	6.4.5	Turn signal switch.....	28
	2.8 Environment.....	13	6.4.6	Horn button	29
	2.9 Owner's Manual	14	6.5	Switches on the right side of the handlebar	30
3	IMPORTANT NOTES.....	15	6.5.1	Emergency OFF switch	30
	3.1 Warranty	15	6.5.2	Electric starter button	30
	3.2 Operating and auxiliary substances	15	6.6	Ignition/steering lock	31
	3.3 Spare parts, accessories	15	6.7	immobilizer	31
	3.4 Service	16	6.8	Locking the steering.....	32
	3.5 Figures	16	6.9	Unlocking the steering.....	33
	3.6 Customer service.....	16	6.10	Opening the filler cap.....	33
4	VIEW OF VEHICLE	18	6.11	Closing the filler cap	35
	4.1 View of vehicle, front left side (example)	18	6.12	Fuel cocks.....	36
	4.2 View of vehicle, rear right side (example).....	20	6.13	Opening the storage compartment	36
5	SERIAL NUMBERS	22	6.14	Closing the storage compartment.....	37
	5.1 Chassis number	22	6.15	Seat lock.....	37
	5.2 Type label	22	6.16	Tool set.....	38
	5.3 Key number.....	23	6.17	Grab handles	38
	5.4 Engine number	23	6.18	Luggage rack plate.....	39
	5.5 Fork part number	24	6.19	Passenger footrest.....	39

TABLE OF CONTENTS





6.20	Shift lever	40	7.9.17	"Clock/Date"	58
6.21	Foot brake lever	41	7.9.18	"Shift Light"	58
6.22	Side stand.....	41	7.9.19	"Heat Grip" (optional)	59
7	COMBINATION INSTRUMENT	42	7.9.20	"DRL"	59
7.1	Overview	42	8	ERGONOMICS	60
7.2	Activation and test	42	8.1	Handlebar position	60
7.3	Matrix display	43	8.2	Adjusting the handlebar position 	60
7.4	Segment display	43	8.3	Adjusting the wind shield	62
7.5	Indicator lamps.....	44	8.4	Adjusting basic position of clutch lever	63
7.6	Message on the matrix display.....	45	8.5	Adjusting the basic position of the hand brake lever	64
7.7	Shift warning light	46	8.6	Rider footrests.....	64
7.8	service display	47	8.7	Adjusting the footrests 	65
7.9	Matrix display menu	47	8.8	Checking the basic position of the shift lever	67
7.9.1	"Favorites".....	47	8.9	Adjusting the basic position of the shift lever 	68
7.9.2	"Trip 1"	48	8.10	Adjusting the basic position of the foot brake lever 	69
7.9.3	"Trip 2"	48	9	PREPARING FOR USE.....	71
7.9.4	"General Info".....	49	9.1	Advice on first use	71
7.9.5	"Set Favorites"	49	9.2	Running in the engine	72
7.9.6	"Settings"	50	9.3	Loading the vehicle	73
7.9.7	"Warning"	50	10	RIDING INSTRUCTIONS.....	75
7.9.8	"Heating" (optional).....	51	10.1	Checks and maintenance measures when preparing for use.....	75
7.9.9	"MTC/ABS".....	51	10.2	Starting.....	76
7.9.10	"Drive Mod"	52	10.3	Starting off.....	77
7.9.11	Menu overview.....	54	10.4	Shifting, riding	77
7.9.12	"Language".....	55	10.5	Applying the brakes.....	81
7.9.13	"Distance"	56	10.6	Stopping, parking.....	83
7.9.14	"Temp"	56	10.7	Transport	84
7.9.15	"Pressure"	57			
7.9.16	"Fuel Cons"	57			

TABLE OF CONTENTS

10.8	Refueling	85	13.15	Checking the play of the steering head bearing ...	106
11	SERVICE SCHEDULE	87	13.16	Removing the bottom triple clamp cover.....	107
11.1	Additional information	87	13.17	Installing the bottom triple clamp cover	108
11.2	Required work	87	13.18	Removing the front side cover	109
11.3	Recommended work	89	13.19	Installing the front side cover	110
12	SUSPENSION SETTING.....	90	13.20	Removing the mask spoiler 🛠️.....	112
12.1	Adjusting the rebound damping of the shock absorber.....	90	13.21	Installing the mask spoiler 🛠️	114
12.2	Adjusting the spring preload of the shock absorber.....	90	13.22	Removing the front fender	117
13	SERVICE WORK ON THE CHASSIS.....	92	13.23	Installing the front fender	117
13.1	Lifting the motorcycle with the rear lifting gear	92	13.24	Cleaning the dust boots of the fork legs 🛠️.....	118
13.2	Removing the rear of motorcycle from the lifting gear.....	92	13.25	Removing the tank cover.....	119
13.3	Lifting the motorcycle with the front lifting gear....	93	13.26	Installing the tank cover	121
13.4	Taking the motorcycle from the front lifting gear ...	94	13.27	Removing the wind shield	123
13.5	Raising the motorcycle with the work stand (inserted) 🛠️.....	95	13.28	Installing the wind shield.....	123
13.6	Removing the motorcycle from the work stand (inserted) 🛠️.....	96	13.29	Removing the engine guard.....	124
13.7	Removing the seat	97	13.30	Installing the engine guard	124
13.8	Mounting the seat	97	14	BRAKE SYSTEM	125
13.9	Checking for chain dirt	98	14.1	ABS / anti-blocking system	125
13.10	Cleaning the chain	98	14.2	Checking the brake discs	126
13.11	Checking the chain tension	99	14.3	Checking the brake fluid level of the front brake.....	127
13.12	Adjusting the chain tension.....	100	14.4	Adding front brake fluid 🛠️.....	128
13.13	Checking the chain, rear sprocket, and engine sprocket.....	102	14.5	Checking the front brake linings	130
13.14	Checking/correcting the fluid level of the hydraulic clutch.....	105	14.6	Checking the rear brake fluid level.....	131
			14.7	Adding rear brake fluid 🛠️.....	132
			14.8	Checking the rear brake linings	133
			15	WHEELS, TIRES	135
			15.1	Removing the front wheel 🛠️.....	135
			15.2	Installing the front wheel 🛠️	137

TABLE OF CONTENTS







15.3	Removing the rear wheel 	140	19	SERVICE WORK ON THE ENGINE	179
15.4	Installing the rear wheel 	142	19.1	Checking the engine oil level	179
15.5	Checking the rear hub rubber dampers 	145	19.2	Changing the engine oil and oil filter, cleaning the oil screens 	180
15.6	Checking the tire condition	147	19.3	Adding engine oil	184
15.7	Checking the tire air pressure	148	20	CLEANING, CARE	187
16	ELECTRICAL SYSTEM	150	20.1	Cleaning motorcycle	187
16.1	daytime running light	150	20.2	Checks and maintenance steps for winter operation	189
16.2	Removing the battery 	150	21	STORAGE	191
16.3	Installing the battery 	152	21.1	Storage	191
16.4	Recharging the battery 	153	21.2	Preparing for use after storage	192
16.5	Changing the main fuse	157	22	TROUBLESHOOTING	193
16.6	Changing the fuses in the fuse box	159	23	TECHNICAL DATA	195
16.7	Removing the headlight mask with the headlight	161	23.1	Engine	195
16.8	Refitting the headlight mask with the headlight	162	23.2	Engine tightening torques	196
16.9	Changing the low beam bulb	163	23.3	Capacities	199
16.10	Changing the high beam bulb	164	23.3.1	Engine oil	199
16.11	Changing the turn signal bulb	166	23.3.2	Coolant	200
16.12	Checking the headlight setting	167	23.3.3	Fuel	200
16.13	Adjusting the headlight range	168	23.4	Chassis	200
16.14	Activating/deactivating the ignition key	169	23.5	Electrical system	201
17	COOLING SYSTEM	174	23.6	Tires	202
17.1	Checking the coolant level in the compensating tank	174	23.7	Fork	202
17.2	Correcting the coolant level in the compensating tank	175	23.8	Shock absorber	203
18	TUNING THE ENGINE	177	23.9	Chassis tightening torques	204
18.1	"Drive Mod"	177	24	SUBSTANCES	208
18.2	Traction control (TC)	177	25	AUXILIARY SUBSTANCES	211
			26	STANDARDS	213

TABLE OF CONTENTS

27	INDEX OF SPECIAL TERMS	214
28	LIST OF ABBREVIATIONS.....	215
29	LIST OF SYMBOLS.....	216
29.1	Red symbols.....	216
29.2	Yellow and orange symbols.....	216
29.3	Green and blue symbols.....	216
	INDEX	218

1.1 Symbols used

The meaning of specific symbols is described below.



Indicates an expected reaction (e.g. of a work step or a function).



Indicates an unexpected reaction (e.g. of a work step or a function).



All work marked with this symbol requires specialist knowledge and technical understanding. In the interest of your own safety, have these jobs performed by an authorized KTM workshop. There, your motorcycle will be optimally cared for by specially trained experts using the specialist tools required.



Indicates a page reference (more information is provided on the specified page).



Indicates information with more details or tips.



Indicates the result of a testing step.

1 MEANS OF REPRESENTATION

1.2 Formats used

The typographical formats used in this document are explained below.

Specific name	Identifies a proprietary name.
Name®	Identifies a protected name.
Brand™	Identifies a brand available on the open market.
<u>Underlined terms</u>	Refer to technical details of the vehicle or indicate technical terms that are explained in the glossary.

2.1 Use definition - intended use

KTM sport motorcycles are designed and constructed to meet the normal demands of regular road and light offroad operation (dirt roads), but not for use on race courses.



Info

The motorcycle is only authorized for operation on public roads in the homologated version.

2.2 Safety advice

A number of safety instructions need to be followed to operate the vehicle safely. Therefore, read this manual carefully. The safety instructions are highlighted in the text and are referred to at the relevant passages.



Info

The vehicle has various information and warning labels at prominent locations. Do not remove information/warning labels. If they are missing, you or others may not recognize dangers and may therefore be injured.

2.3 Degrees of risk and symbols



Danger

Indicates a danger that will immediately and invariably lead to fatal or serious permanent injury if the appropriate measures are not taken.



Warning

Indicates a danger that is likely to lead to fatal or serious injury if the appropriate measures are not taken.



Caution

Indicates a danger that may lead to minor injuries if the appropriate measures are not taken.

Note

Indicates a danger that will lead to considerable machine and material damage if the appropriate measures are not taken.



Warning

Indicates a danger that will lead to environmental damage if the appropriate measures are not taken.

2.4 Tampering warning

Tampering with the noise control system is prohibited. Federal law prohibits the following acts or the causing thereof:

- 1 The removal or rendering inoperative by any person other than for purposes of maintenance, repair, or replacement, of any device or element of design incorporated into any new vehicle for the purpose of noise control prior to its sale or delivery to the ultimate purchaser or while it is in use, or
- 2 the use of the vehicle after such device or element of design has been removed or rendered inoperative by any person.

Among those acts presumed to constitute tampering are the acts listed below:

- 1 Removal or puncturing of the main silencer, baffles, header pipes or any other components which conduct exhaust gases.
- 2 Removal or puncturing of parts of the intake system.
- 3 Lack of proper maintenance.
- 4 Replacing moving part of the vehicle, or parts of the exhaust or intake system, with parts other than those specified by the manufacturer.

2.5 Safe operation



Danger

Danger of accidents Danger arising from the rider's judgement being impaired.

- Do not operate the vehicle while under the influence of alcohol, drugs and certain medications or physically or mentally impaired.



Danger

Danger of poisoning Exhaust gases are toxic and inhaling them may result in unconsciousness and/or death.

- When running the engine, always make sure there is sufficient ventilation, and do not start or run the engine in an enclosed space without an effective exhaust extraction system.



Warning

Danger of burns Some vehicle components become very hot when the vehicle is operated.

- Do not touch hot components such as exhaust system, radiator, engine, shock absorber, and the brake system. Allow these components to cool down before starting work on them.

Only operate the vehicle when it is in perfect technical condition, in accordance with its intended use, and in a safe and environmentally compatible manner.

The vehicle should only be used by trained persons. An appropriate driver's license is needed to ride the vehicle on public roads.

Have malfunctions that impair safety promptly eliminated by an authorized KTM workshop.

Adhere to the information and warning labels on the vehicle.

2.6 Protective clothing



Warning

Risk of injury Missing or poor protective clothing presents an increased safety risk.

- Wear protective clothing (helmet, boots, gloves, pants and jacket with protectors) every time you ride the vehicle. Always wear protective clothing that is in good condition and meets the legal requirements.

In the interest of your own safety, KTM recommends that you only operate the vehicle while wearing protective clothing.

2.7 Work rules

Special tools are necessary for some of the work. These are not included with the vehicle and can be ordered under the number in parentheses. Ex: valve spring mounter (59029019000)

During assembly, non-reusable parts (e.g. self-locking screws and nuts, seals and seal rings, O-rings, pins, lock washers) must be replaced by new parts.

Where thread lockers are used on screw connections (e.g., **Loctite**®), follow the instructions for use from the manufacturer.

Parts that you want to reuse following repairs and servicing should be cleaned and checked for damage and wear. Change damaged or worn parts.

Following repairs or servicing, the vehicle must be checked for roadworthiness.

2.8 Environment

If you use your motorcycle responsibly, you can ensure that problems and conflicts do not occur. To protect the future of the motorcycle sport, make sure that you use your motorcycle legally, display environmental consciousness, and respect the rights of others.

When disposing of used oil, other operating and auxiliary fluids, and used components, comply with the laws and regulations of the respective country.

Because motorcycles are not subject to the EU regulations governing the disposal of used vehicles, there are no legal regulations that pertain to the disposal of an end-of-life motorcycle. Your authorized KTM dealer will be glad to advise you.

2.9 Owner's Manual

It is important that you read this Owner's Manual carefully and completely before making your first trip. The Owner's Manual contains useful information and many tips on how to operate, handle, and maintain your motorcycle. Only then will you find out how to customize the vehicle ideally for your own use and how you can protect yourself from injury.

Keep the Owner's Manual in an accessible place to enable you to refer to it as needed.

If you would like to know more about the vehicle or have questions on the material you read, please contact an authorized KTM dealer.

The Owner's Manual is an important component of the vehicle and should be handed over to the new owner if the vehicle is sold.

3.1 Warranty

The work specified in the service schedule may only be performed in an authorized KTM workshop and must be recorded in both the Service & Warranty Booklet and in **KTM Dealer.net**, otherwise any warranty coverage will become void. No warranty claims can be considered for damage resulting from manipulations and/or alterations to the vehicle.

Additional information on the manufacturer or implied warranty and the procedures involved can be found in the service & warranty booklet.

3.2 Operating and auxiliary substances



Warning

Environmental hazard Improper handling of fuel is a danger to the environment.

- Do not allow fuel to get into the ground water, the ground, or the sewage system.

Use operating and auxiliary substances (such as fuel and lubricants) as specified in the Owner's Manual.

3.3 Spare parts, accessories

For your own safety, only use spare parts and accessory products that are approved and/or recommended by KTM and have them installed by an authorized KTM workshop. KTM accepts no liability for other products and any resulting damage or loss.

Certain spare parts and accessory products are specified in parentheses in the descriptions. Your authorized KTM dealer will be glad to advise you.

The current **KTM PowerParts** for your vehicle can be found on the KTM website.

International KTM Website: <http://www.ktm.com>

3.4 Service

A prerequisite for perfect operation and prevention of premature wear is that the service, care and tuning work on the engine and chassis are properly carried out as described in the owner's manual. Poor adjustment and tuning of the engine and suspension can lead to damage and breakage of components.

Using the motorcycle in extreme operating conditions, e.g. on very muddy and wet roads or in a dusty and dry environment, can lead to above-average wear of components, such as the drive train, brakes or air filter. For this reasons, it may be necessary to service or replace worn parts before the interval listed in the service schedule is reached.

It is imperative that you adhere to the stipulated run-in times and service intervals. If you observe these exactly, you will ensure a much longer service life for your motorcycle.

3.5 Figures

The figures contained in the manual may depict special equipment.

In the interest of clarity, some components may be shown disassembled or may not be shown at all. It is not always necessary to disassemble the component to perform the activity in question. Please follow the instructions in the text.

3.6 Customer service

Your authorized KTM dealer will be happy to answer any questions you may have on your vehicle and KTM.

A list of authorized KTM dealers can be found on the KTM website.

International KTM Website: <http://www.ktm.com>

4 VIEW OF VEHICLE

4.1 View of vehicle, front left side (example)



4 VIEW OF VEHICLE

1	Clutch lever (☛ p. 25)
2	Seat lock (☛ p. 37)
3	Tool set (☛ p. 38)
4	Grab handles (☛ p. 38)
5	Luggage rack plate (☛ p. 39)
6	Passenger footrest (☛ p. 39)
7	Rider footrests (☛ p. 64)
8	Shift lever (☛ p. 40)
9	Side stand (☛ p. 41)
10	Engine oil level viewer
11	Fuel cocks (☛ p. 36)

4 VIEW OF VEHICLE

4.2 View of vehicle, rear right side (example)

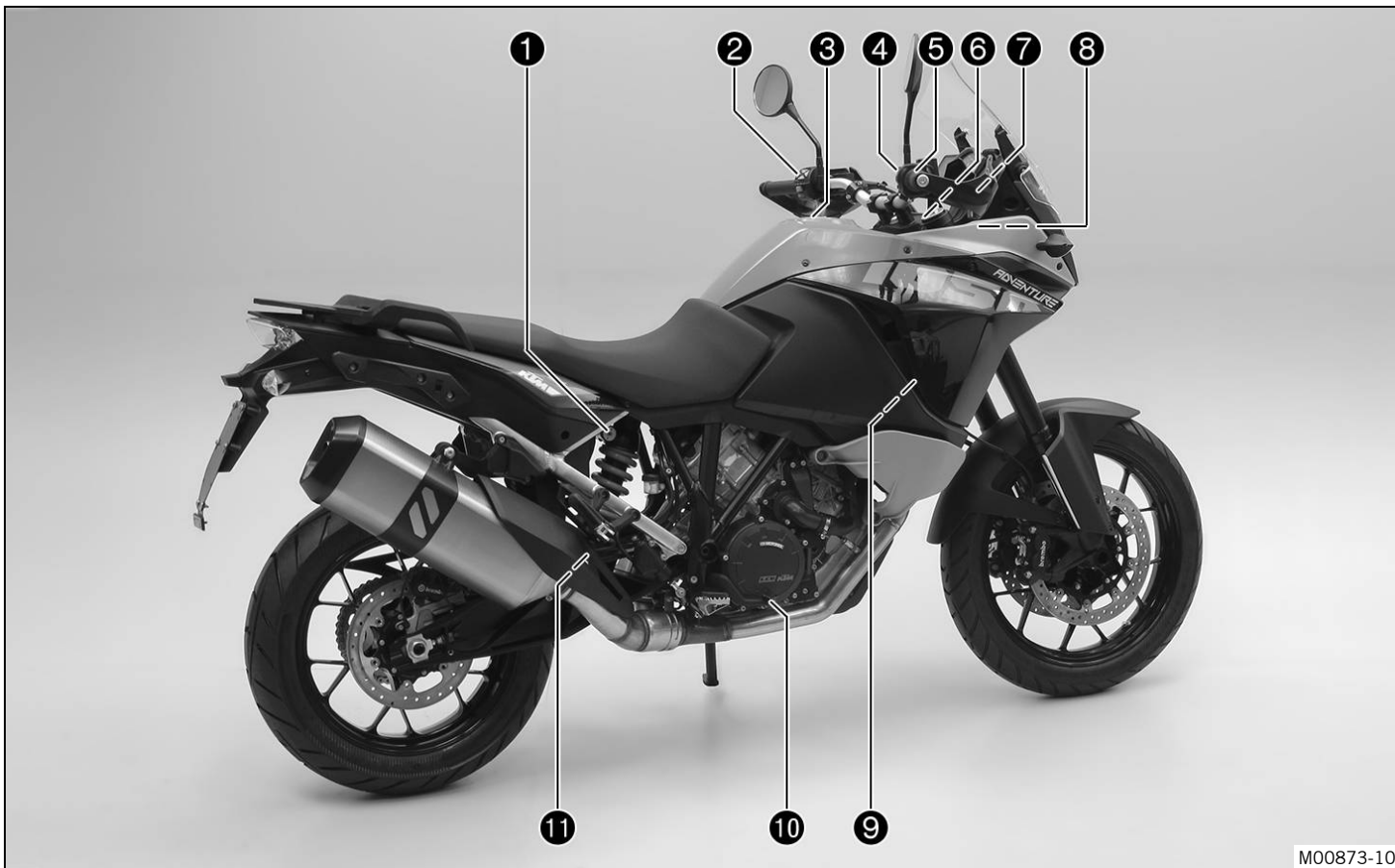

4 VIEW OF VEHICLE

1	Shock absorber, spring preload setting
2	Combination switch (☛ p. 26)
3	Filler cap
4	Electric starter button (☛ p. 30)
4	Emergency OFF switch (☛ p. 30)
5	Throttle grip (☛ p. 26)
6	Ignition/steering lock (☛ p. 31)
7	Hand brake lever (☛ p. 25)
8	Storage compartment
9	Cooling system compensating tank
10	Foot brake lever (☛ p. 41)
11	Shock absorber, rebound setting

5.1 Chassis number

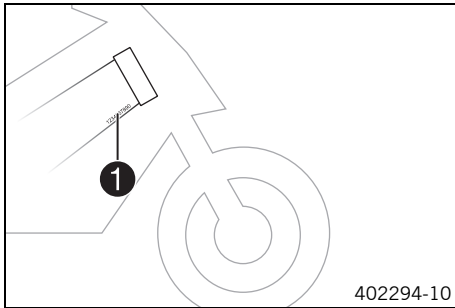

The chassis number ❶ is stamped on the bottom right of the frame behind the steering head.

The chassis number is also shown on the type label.

5.2 Type label

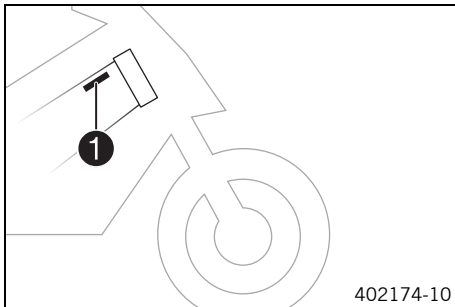

The type label ❶ is on the top right of the frame behind the steering head.

5.3 Key number

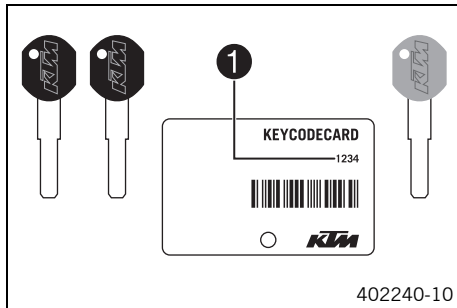

The key number **Code number 1** can be found on the **KEYCODECARD**.



Info

You need the key number to order a spare key. Keep the **KEYCODECARD** in a safe place.

Use the orange programming key to activate and deactivate the black ignition key. Keep the orange programming key in a safe place: it must only be used for learning and programming functions.

5.4 Engine number

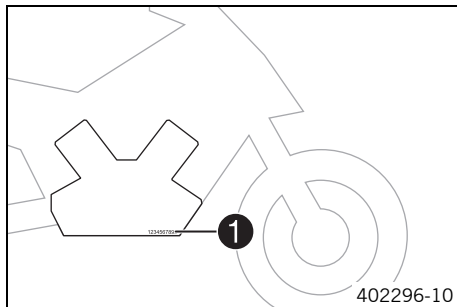

The engine number **1** is stamped on the right side of the engine.

5.5 Fork part number

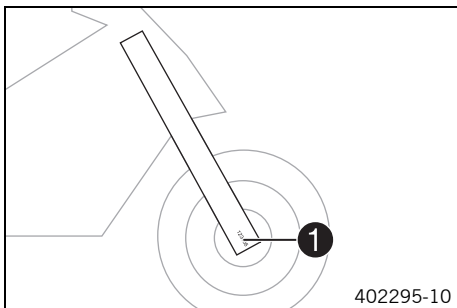

The fork part number ❶ is stamped on the inner side of the fork stub.

5.6 Shock absorber article number

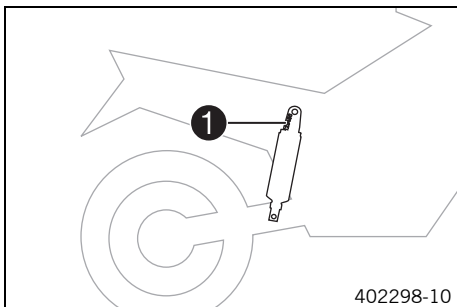

The shock absorber article number ❶ is stamped on the top of the shock absorber.

6.1 Clutch lever

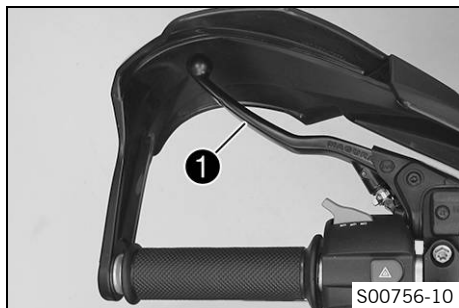

The clutch lever ❶ is fitted on the left side of the handlebar. The clutch is hydraulically operated and self-adjusting.

6.2 Hand brake lever

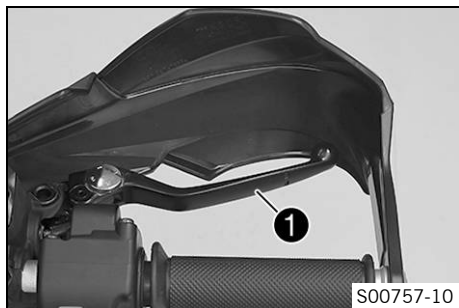

The hand brake lever ❶ is fitted on the right side of the handlebar. The front brake is engaged using the hand brake lever.

6.3 Throttle grip

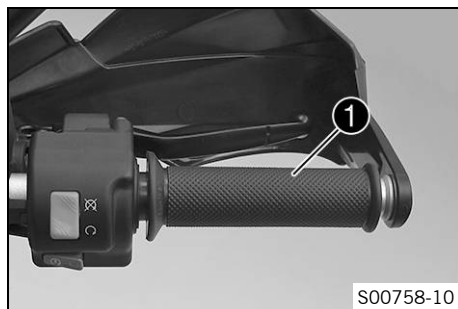

The throttle grip ❶ is fitted on the right side of the handlebar.

6.4 Switches on the left side of the handlebar

6.4.1 Combination switch

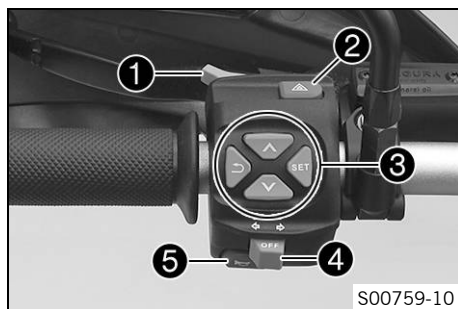

The combination switch is fitted on the left side of the handlebar.

Overview of the left combination switch

1	Light switch (☛ p. 27)
2	Hazard warning flasher switch (☛ p. 27)
3	Menu switch (☛ p. 28)
4	Turn signal switch (☛ p. 28)
5	Horn button (☛ p. 29)

6.4.2 Light switch

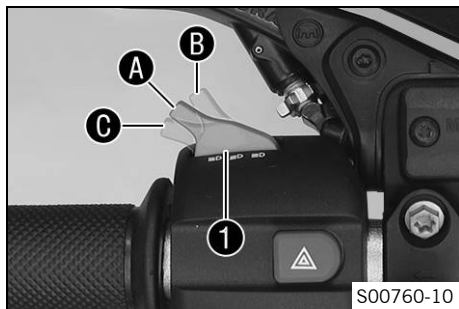

The light switch **1** is fitted on the combination switch on the left.

Possible states

	Low beam on – Light switch in position A . In this position, the low beam and tail light are switched on.
	High beam on – Push the light switch to position B . In this position, the high beam and the tail light are switched on.
	Headlight flasher. – Push the light switch into position C .

6.4.3 Hazard warning flasher switch



The hazard warning flasher switch **1** is fitted on the combination switch on the left. The hazard warning flasher is used to indicate emergency situations.

Info

The hazard warning flasher can be activated or deactivated while the ignition is switched on or up to 60 seconds after the ignition is switched off. Only keep the hazard warning flasher activated as long as necessary as it depletes the battery.

Possible states

	Hazard warning flasher on – All four turn signals and the green turn signal indicator lights in the combination instrument flash.
--	---

6.4.4 Menu switch



The menu switch is fitted in the middle of the left combination switch. The menu buttons are used to control the matrix display on the combination instrument.

Button **1** is the **UP** button.

Button **2** is the **DOWN** button.

Button **3** is the **SET** button.

Button **4** is the **BACK** button.

6.4.5 Turn signal switch



The turn signal switch **1** is fitted on the combination switch on the left.

Possible states

OFF	Turn signal off – Push the turn signal switch toward the switch housing.
	Left turn signal, on – Turn signal switch pressed to the left. The turn signal switch returns automatically to the central position after use.
	Right turn signal, on – Turn signal switch pressed to the right. The turn signal switch returns automatically to the central position after use.

To switch off the turn signal, press the turn signal switch towards the switch case.



Info

An automatic turn signal switch-off function (**ATIR**) is available as an optional software feature.

The **ATIR** function uses a time and distance counter.

If the turn signal has been on for at least 10 seconds and 150 meters of riding distance, the turn signal is switched off.

If the vehicle is stationary, both counters are stopped.



If the turn signal switch is reactivated, both counters are reset.

6.4.6 Horn button



The horn button ① is fitted on the combination switch on the left.

Possible states

- Horn button  in basic position.
- Horn button  pressed – The horn is operated in this position.



6.5 Switches on the right side of the handlebar

6.5.1 Emergency OFF switch



The emergency OFF switch ❶ is fitted on the right side of the handlebar.

Possible states

	Emergency OFF switch off – In this position, the ignition circuit is interrupted, a running engine stops, and a non-running engine cannot be started. A message appears on the matrix display.
	Emergency OFF switch on – This position is required for operation; the ignition circuit is closed.

6.5.2 Electric starter button



The electric starter button ❶ is fitted on the right side of the handlebar.

Possible states

- Electric starter button ❸ in basic position.
- Electric starter button ❸ is pressed – In this position, the electric starter is actuated.

6.6 Ignition/steering lock



The ignition/steering lock ❶ is located in front of the upper triple clamp.



Info

The ignition may only be switched on using a black ignition key. With the orange programming key, you can activate or deactivate the black ignition key.

Possible states

	<p>Ignition off OFF – In this position, the ignition circuit is interrupted, a running engine stops, and a non-running engine will not start. The black ignition key can be removed.</p>
	<p>Ignition on ON – In this position, the ignition circuit is closed and the engine can be started.</p>
	<p>Steering locked – In this position, the ignition circuit is interrupted and the steering locked. The black ignition key can be removed.</p>

6.7 immobilizer

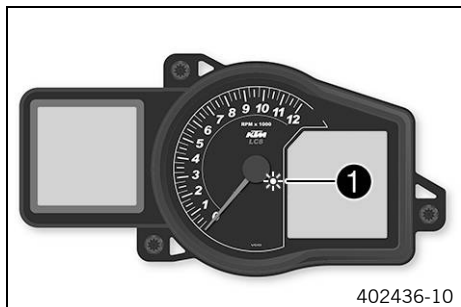

The electronic immobilizer secures the vehicle against unauthorized use.

The immobilizer is activated automatically and the engine electronics are locked when the ignition key is withdrawn.

The immobilizer indicator lamp ❶ can indicate errors by flashing.

If the optional alarm system is installed, the immobilizer indicator lamp ❶ flashes when the alarm system is switched on.



Info

The ignition key contains electronic components. Never attach multiple ignition keys to a single key ring; this may cause mutual interference.

A lost black ignition key must be deactivated to prevent unauthorized persons from operating the vehicle.

The black ignition keys are activated when delivered.

Another two spare ignition keys (key number on the **KEYCODECARD**) can be ordered from an authorized KTM workshop; they need to be activated for use.

6.8 Locking the steering

Note

Danger of damage The parked vehicle may roll away or fall over.

- Always place the vehicle on a firm and even surface.



- Park the vehicle.
- Turn the handlebar all the way to the left.
- Insert the key into the ignition/handlebar lock, press in, and turn to the left. Remove the key.
- ✓ Steering is no longer possible.

6.9 Unlocking the steering

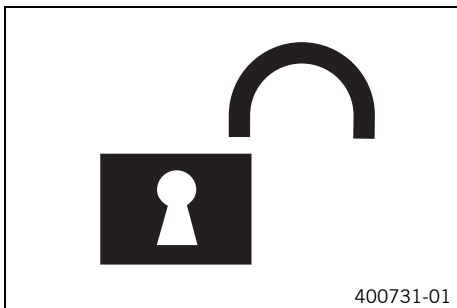

- Insert the key into the ignition/handlebar lock, press in, and turn to the right. Remove the key.
- ✓ You can now steer the bike again.

6.10 Opening the filler cap



Danger

Fire hazard Fuel is highly flammable.

- Never refuel the vehicle near open flames or burning cigarettes, and always switch off the engine first. Be careful that no fuel is spilt, especially on hot vehicle components. Clean up spilt fuel immediately.
- The fuel in the fuel tank expands when warm and may emerge if overfilled. Follow the instructions on refueling.



Warning

Danger of poisoning Fuel is poisonous and a health hazard.

- Fuel must not come into contact with the skin, eyes, or clothing. Do not breathe in the fuel vapors. If contact occurs with the eyes, rinse with water immediately and contact a physician. Immediately clean contaminated areas on the skin with soap and water. If fuel is swallowed, contact a physician immediately. Change clothing that has been contaminated with fuel. Store fuel properly in a suitable canister and keep away from children.



Warning

Environmental hazard Improper handling of fuel is a danger to the environment.

- Do not allow fuel to get into the ground water, the ground, or the sewage system.

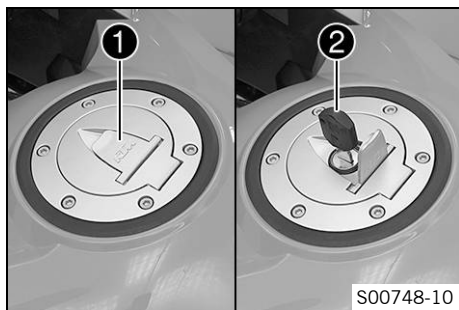

- Lift cover **1** of the filler cap and insert ignition key **2** in the fuel tank lock.

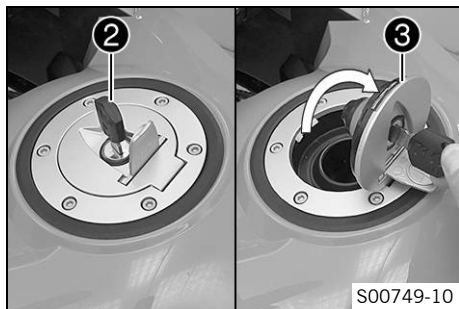

Note

Danger of damage Ignition key breakage.

- To take pressure off of the ignition key, push down on the filler cap. Damaged ignition keys must be replaced.
- Turn ignition key **2** clockwise.
- Fold open filler cap **3**.

6.11 Closing the filler cap

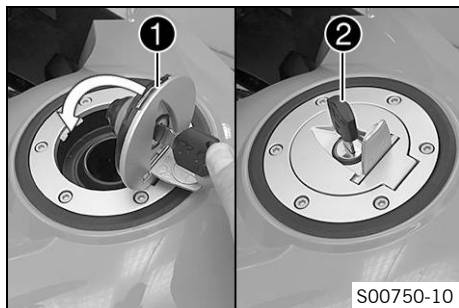

- Fold down filler cap ①.
- Turn ignition key ② clockwise.

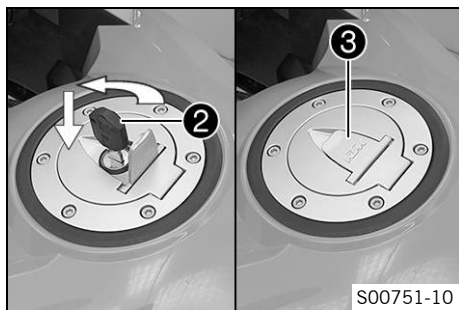

- Push down the filler cap and turn the ignition key ② counterclockwise until the tank lock closes.



Warning

Fire hazard Fuel is highly flammable, poisonous and harmful to your health.

- After closing the filler cap, ensure that it is locked properly. Change clothing that has been contaminated with fuel. Immediately clean contaminated areas on the skin with soap and water.
-
- Remove ignition key ② and close cover ③.

6.12 Fuel cocks

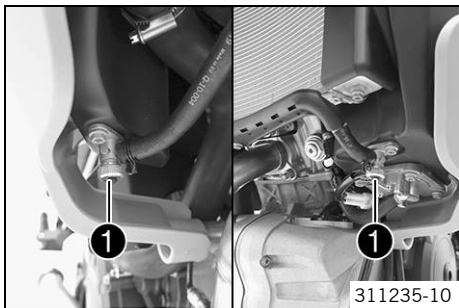

A fuel cock ❶ is located on each side of the fuel tank.



Info

The fuel cocks must always be open during operation.
The fuel cocks are only closed to remove the fuel tank.

Possible states

- Fuel cocks are closed – A level equalization cannot take place and fuel cannot flow out of the fuel tank.
- Fuel cocks are open – A level equalization can take place and fuel can flow out of the fuel tank.

6.13 Opening the storage compartment

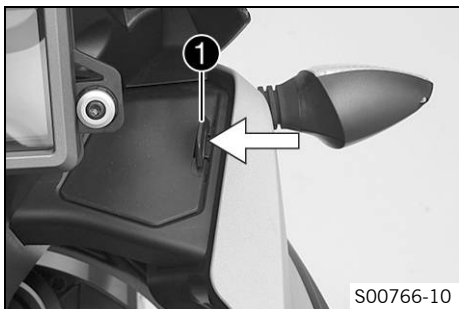

- Press lock ❶ in the direction of the arrow and lift the cover at the same time.

6.14 Closing the storage compartment

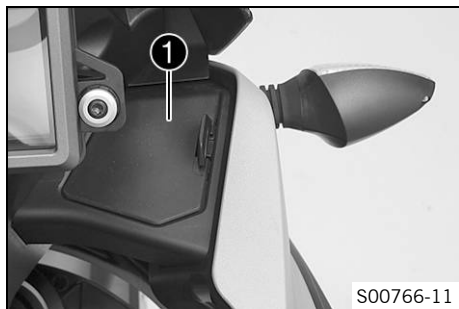

- Press cover **1** downward.
- ✓ The lock engages audibly.

6.15 Seat lock

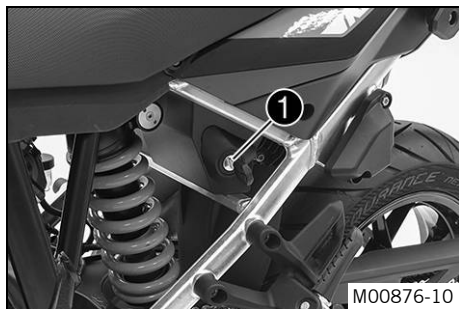

The seat lock **1** is located on the left side of the vehicle. It can be unlocked using the ignition key.

6.16 Tool set

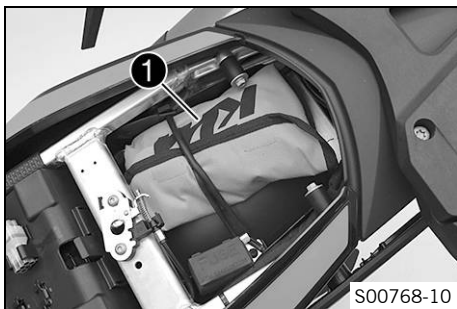

The tool set ① is located in the storage compartment under the seat.

6.17 Grab handles



The passenger can hold onto grab handles ① during the trip.

6.18 Luggage rack plate



The luggage rack plate ❶ is located behind the seat. The base plate of a luggage system (optional) can be attached to the luggage rack plate. The luggage rack plate may not be loaded with more than the specified weight.

Maximum permissible load on luggage rack plate	8 kg (18 lb.)
--	---------------



Info

Note the information provided by the luggage manufacturer.

6.19 Passenger footrest

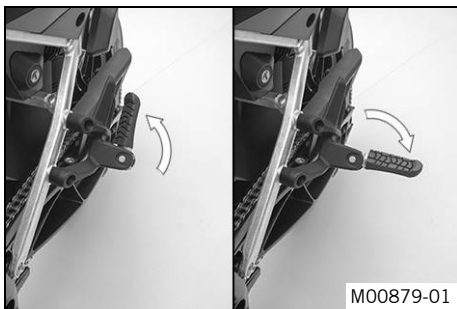

The passenger footrests are foldable.

Possible states

- Passenger footrest folded in – For operation without a passenger.
- Passenger footrest folded out – For operation with a passenger.

6.20 Shift lever

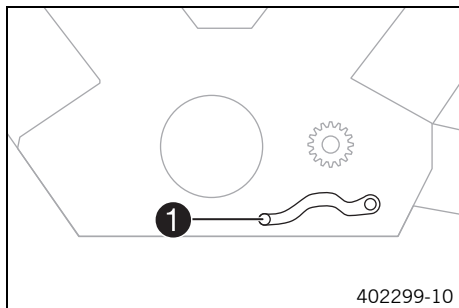

The shift lever **1** is fitted on the left side of the engine.

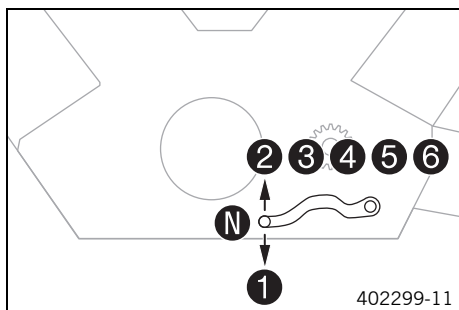

The gear positions can be seen in the figure.
The idle position is between the first and second gears.

6.21 Foot brake lever

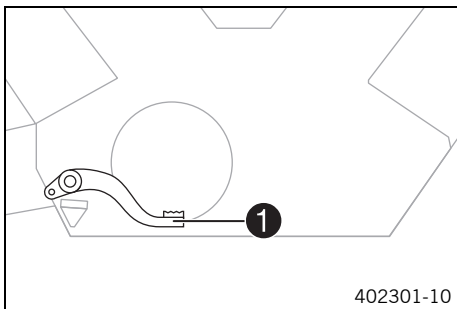

Foot brake lever **1** is located in front of the right footrest. The rear brake is activated using the foot brake lever.

6.22 Side stand

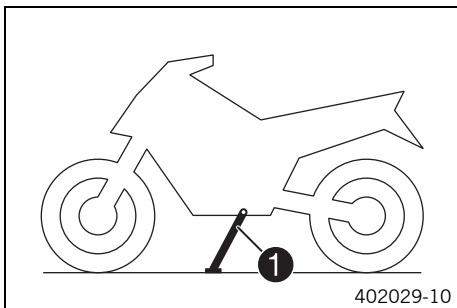

The side stand **1** is located on the left side of the vehicle. The side stand is used for parking the motorcycle.



Info

The side stand must be folded up during motorcycle use. The side stand is coupled with the safety starting system. See the instructions in the "Stopping, parking" chapter.

Possible states

- Side stand folded out – The vehicle can be supported on the side stand. The safety starting system is active.
- Side stand folded in – This position is mandatory when riding the motorcycle. The safety starting system is inactive.

7.1 Overview

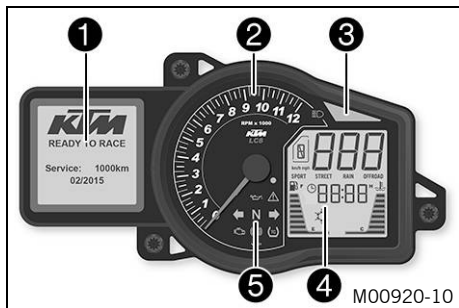

- 1 Matrix display (☛ p. 43)
- 2 Tachometer
- 3 Shift warning light (☛ p. 46)
- 4 Segment display
- 5 Indicator lamps (☛ p. 44)

7.2 Activation and test

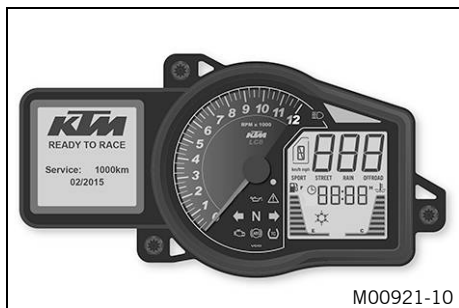

Activation

The combination instrument is activated when the ignition is switched on.

i Info

The brightness of the displays is controlled by a brightness sensor in the combination instrument.

Test

The segment display, the indicator lamps, and the tachometer are briefly activated for a function test.

The welcome text and information on the next service (☛ p. 47) appear on the matrix display.

i Info

If the battery was disconnected, the time and date must be set.

7.3 Matrix display

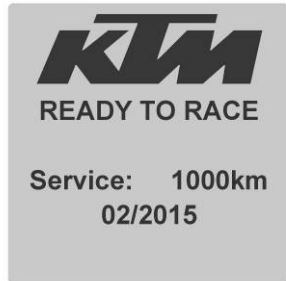

402429-01

The matrix display is controlled using the menu switch (☛ p. 28). After the ignition is switched on, the display shows when the next service (☛ p. 47) is due. If the General warning lamp  lights up among the indicator lamps (☛ p. 44), the corresponding message appears in the matrix display. The **SET** button is used to confirm receipt of the information and the message is cleared.

Messages appear	10 s
-----------------	------

7.4 Segment display













M00865-10

1	Fuel level
2	Time symbol
3	Unit for the speedometer
4	Gear display
5	Speed
6	"Drive Mod" (☛ p. 177)
7	Time
8	Coolant temperature
9	Ice warning

7.5 Indicator lamps









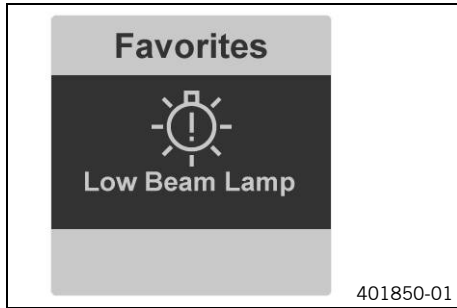



Possible states

	The high beam indicator lamp lights up blue – The high beam is switched on.
	The immobilizer indicator lamp lights up or flashes red – Status or error message for immobilizer/alarm system.
	The oil pressure warning lamp lights up red – Engine oil pressure is too low.
	The general warning lamp lights up yellow – An operating safety (warning) message was detected. This is also shown on the matrix display.
	The left turn signal lamp flashes green simultaneously with the turn signal – The left turn signal is switched on.
	The idle indicator lamp lights up green – The transmission is shifted to idle.
	The right turn signal lamp flashes green simultaneously with the turn signal – The right turn signal is switched on.
	The engine warning lamp lights up/flashes yellow – The engine control unit has detected a fault.
	The ABS lamp lights up/flashes yellow – ABS is not active. The ABS lamp also lights up when an error is detected.
	The TC lamp lights up/flashes yellow – Traction control is not enabled or is currently intervening. The TC lamp also lights up when an error is detected.

7.6 Message on the matrix display



Possible states

	Engine malfunction – The engine control unit has detected a fault. Visit an authorized KTM workshop.
	General message – General message on operating safety. Visit an authorized KTM workshop.
	ABS warning – ABS is not available. Visit an authorized KTM workshop.
	Traction control – Traction control is not available. Visit an authorized KTM workshop.
	Engine oil pressure – Engine oil pressure is too low. Switch off the engine immediately. Contact an authorized KTM workshop.
	Lighting system – An element of the lighting system has failed. Change the faulty light, or visit an authorized KTM workshop.
	Cooling water temperature – The cooling water temperature is too high. Switch off the engine. Contact an authorized KTM workshop.
	Fuel reserve – The fuel supply is dwindling. Refuel at the next opportunity.
	Icy road symbol – The roads may be icy. Adjust your speed to the road conditions.
	Battery voltage – The battery voltage is too low. Recharge the battery with a suitable battery charger.
	Service – A service is due. Contact an authorized KTM workshop.

	Emergency OFF switch – The emergency OFF switch is off.
---	---

The messages are displayed in the **"Warning"** menu.

7.7 Shift warning light

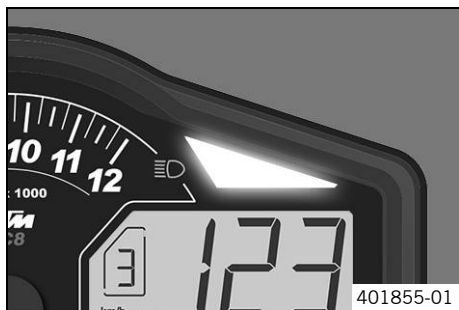

The shift warning light flashes or lights up when the transmission should be shifted. In the **"Shift Light"** menu, the engine speed for the shift warning light can be set. The shift warning light flashes over **"RPM1"** and lights up continuously over **"RPM2"**.

i Info
 In 6th gear, the shift warning light is deactivated when the engine is warm after the first service.
 The shift warning light can be turned on and off in the **"Settings"** menu.

Engine oil temperature	> 35 °C (> 95 °F)
"ODO"	> 1,000 km (> 620 mi)
The shift warning light flashes	> "RPM1"
The shift warning light is continuously lit	> "RPM2"
Engine oil temperature	≤ 35 °C (≤ 95 °F)
"ODO"	< 1,000 km (< 620 mi)
The shift warning light always lights up at	6,500 rpm

7.8 service display



402429-01

After the ignition is switched on, the service display appears briefly. The service intervals depend on the distance traveled or the elapsed time. The event that occurs first is given priority. The exact service intervals can be found in the service schedule.

7.9 Matrix display menu

7.9.1 "Favorites"

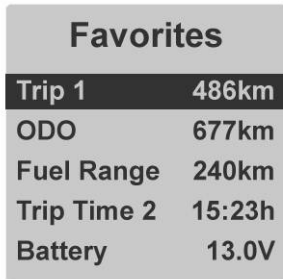

Favorites	
Trip 1	486km
ODO	677km
Fuel Range	240km
Trip Time 2	15:23h
Battery	13.0V

401988-01

- Press the **UP** or **DOWN** button until the "**Favorites**" menu appears on the matrix display. Pressing the **SET** button opens the menu.
- Press the **UP** or **DOWN** button to select the menu item and activate it with the **SET** button.
- Pressing the **BACK** button twice always opens the "**Favorites**" menu.

In the "**Favorites**" menu, you can directly open five menus.

In the "**Set Favorites**" menu, the "**Favorites**" menu can be configured.

7.9.2 "Trip 1"

Trip 1	
Trip 1	973km
Ø Speed 1	89km/h
Ø Cons 1	7.3l
Trip Time 1	15:23h
Fuel Range	240km

L02906-01

- Press the **UP** or **DOWN** button until the **"Trip 1"** menu appears on the matrix display. **"Trip 1"** shows the distance since the last reset, such as between two refueling stops. **"Trip 1"** runs continuously and counts the distance up to **9999**. **"Ø Speed 1"** indicates the average speed based on **"Trip 1"** and **"Trip Time 1"**. **"Ø Cons 1"** indicates the average fuel consumption based on **"Trip 1"** and **"Trip Time 1"**. **"Trip Time 1"** indicates the riding time based on **"Trip 1"** and starts running as soon as a speed signal comes in. **"Fuel Range"** indicates the possible range with the fuel reserve.

Press and hold the button **SET** for 3–5 seconds.

All entries in the **"Trip 1"** menu are cleared.

7.9.3 "Trip 2"

Trip 2	
Trip 2	973km
Ø Speed 2	89km/h
Ø Cons 2	7.3l
Trip Time 2	15:23h
Fuel Range	240km

L02907-01

- Press the **UP** or **DOWN** button until the **"Trip 2"** menu appears on the matrix display. **"Trip 2"** shows the distance since the last reset, such as between two refueling stops. **"Trip 2"** runs continuously and counts the distance up to **9999**. **"Ø Speed 2"** indicates the average speed based on **"Trip 2"** and **"Trip Time 2"**. **"Ø Cons 2"** indicates the average fuel consumption based on **"Trip 2"** and **"Trip Time 2"**. **"Trip Time 2"** indicates the riding time based on **"Trip 2"** and starts running as soon as a speed signal comes in. **"Fuel Range"** indicates the possible range with the fuel reserve.

Press and hold the button **SET** for 3–5 seconds.

All entries in the **"Trip 2"** menu are cleared.

7.9.4 "General Info"

General Info	
Air Temp	14.0°C
Date	01.04.2013
ODO	677km
Battery	13.0V
Oil Temp	

M01255-01

- Press the **UP** or **DOWN** button until the **"General Info"** menu appears on the matrix display.

"Air Temp" displays the ambient air temperature.

"Date" displays the date.

"ODO" displays the total distance covered.

"Battery" displays the battery voltage.

"Oil Temp" - inoperative

7.9.5 "Set Favorites"

Set Favorites	
Trip 1	486km
ODO	677km
Fuel Range	240km
Trip Time 2	15:23h
Battery	13.0V

401991-01

Condition

- The vehicle is stationary.

- Press the **UP** or **DOWN** button until the **"Set Favorites"** menu appears on the matrix display. Pressing the **SET** button opens the menu.
- Press the **UP** or **DOWN** button to select the menu. Press the **SET** button to set the menu for quick selection.

In the **"Set Favorites"** menu, the **"Favorites"** menu can be configured.

7.9.6 "Settings"

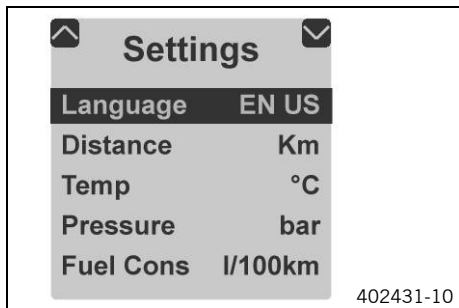

Condition

- The vehicle is stationary.
- Press the **UP** or **DOWN** button until the **"Settings"** menu appears on the matrix display. Pressing the **SET** button opens the menu.

Settings for units or various values are made in the **"Settings"** menu. Several functions can be enabled or disabled.

7.9.7 "Warning"

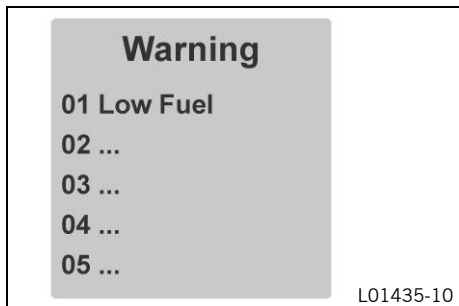

Condition

- Message or warning
- Press the **UP** or **DOWN** button until the **"Warning"** menu appears on the matrix display. Pressing the **SET** button opens the menu.
- Use the **UP** or **DOWN** button to navigate through the warnings.

In the **"Warning"** menu, warnings that occurred are displayed and stored until they are no longer active.

7.9.8 "Heating" (optional)

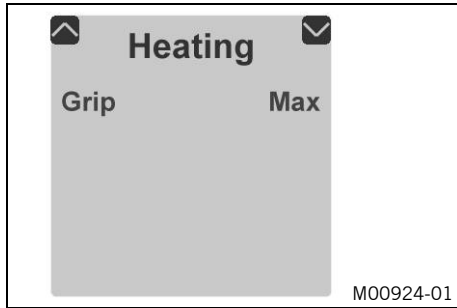

- Press **UP** or **DOWN** button until the "**Heating**" menu appears on the matrix display. Pressing the **SET** button opens the menu.
- Use the **SET** button to select a heating level or to switch off the heated grips.

7.9.9 "MTC/ABS"

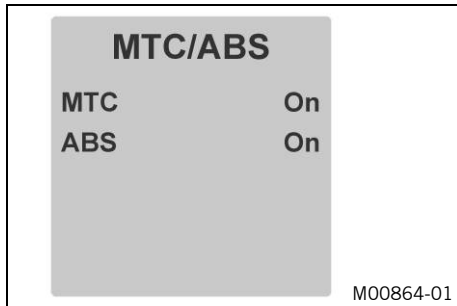

Condition

- The vehicle is stationary.
- Press the **UP** or **DOWN** button until the "**MTC/ABS**" menu appears on the matrix display. In the "**MTC/ABS**" menu, the traction control "**TC**" and the "**ABS**" can be switched off.



Info

After the ignition is switched on, traction control and ABS are enabled again.

7.9.10 "Drive Mod"

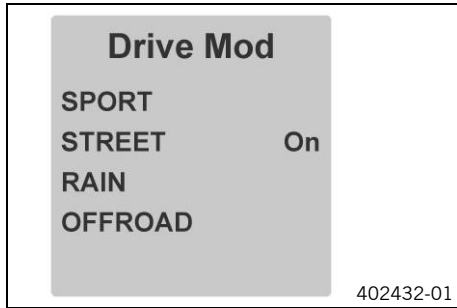

- Press the **UP** or **DOWN** button until the "**Drive Mod**" menu appears on the matrix display. Pressing the **SET** button opens the menu.
- Use the **UP** or **DOWN** button to navigate through the menu. The **SET** button can be used to select engine and traction control settings that are coordinated with each other.
 - ✓ SPORT – homologated performance with very direct response; the traction control allows greater slip on the rear wheel
 - ✓ STREET – homologated performance with balanced response; the traction control allows normal slip on the rear wheel
 - ✓ RAIN – reduced homologated performance for better rideability; the traction control allows normal slip on the rear wheel
 - ✓ OFFROAD (optional) – reduced homologated performance for better rideability; the traction control allows high slip on the rear wheel

7.9.11 Menu overview

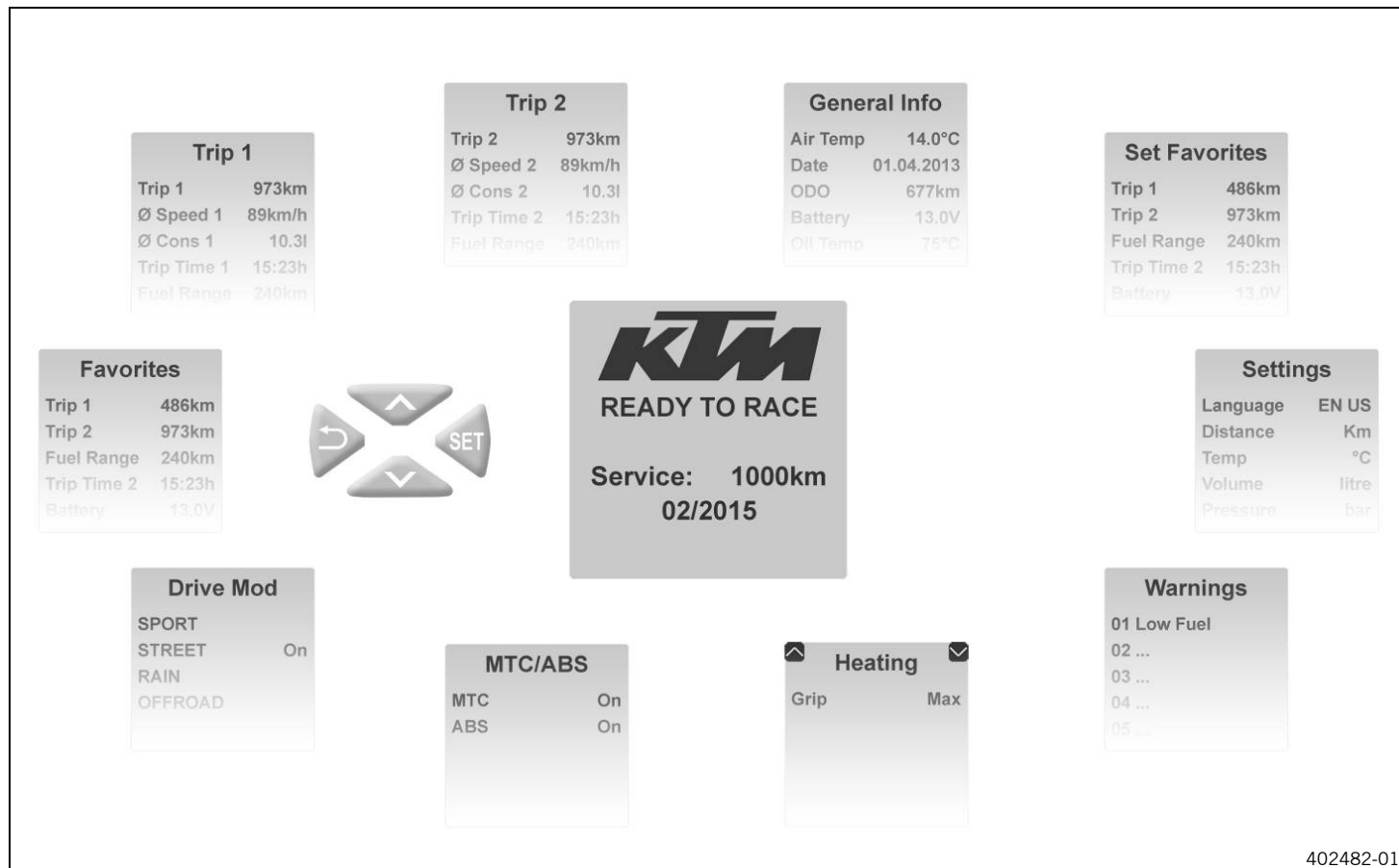

"KTM" start screen

Menu buttons

"Favorites"

"Trip 1"

"Trip 2"

"General Info"

"Set Favorites"

"Settings"

"Warning" (only active if there are messages)

"Heating" (optional)

"MTC/ABS"

"Drive Mod"

7.9.12 "Language"

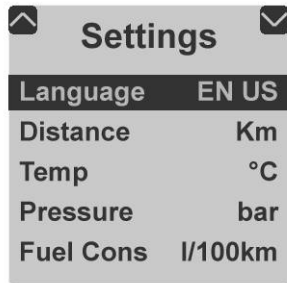

402431-10

Condition

- The vehicle is stationary.
- Press the **UP** or **DOWN** button until the "**Settings**" menu appears on the matrix display. Pressing the **SET** button opens the menu.
- Press the **SET** button again to select the language.

The menu languages are US English, UK English, German, Italian, French, and Spanish.

7.9.13 "Distance"

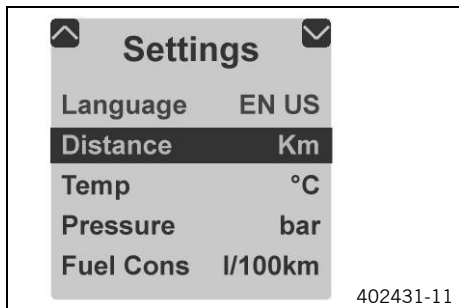

Condition

- The vehicle is stationary.
- Press the **UP** or **DOWN** button until the "**Settings**" menu appears on the matrix display. Pressing the **SET** button opens the menu.
- Press the **UP** or **DOWN** button until "**Distance**" is highlighted in black on the matrix display. Pressing the **SET** button again sets the unit of measure.

Select kilometers "**km**" or miles "**mi**" for the distance.

7.9.14 "Temp"

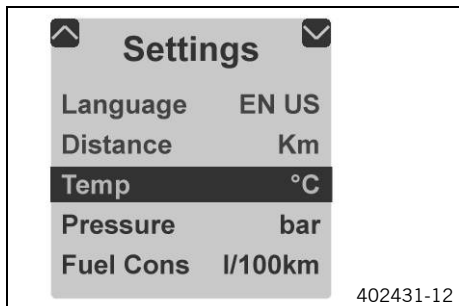

Condition

- The vehicle is stationary.
- Press the **UP** or **DOWN** button until the "**Settings**" menu appears on the matrix display. Pressing the **SET** button opens the menu.
- Press the **UP** or **DOWN** button until "**Temp**" is highlighted in black on the matrix display. Pressing the **SET** button again sets the unit of measure.

Select "**C**" or "**F**" for the temperature indicator.

7.9.15 "Pressure"

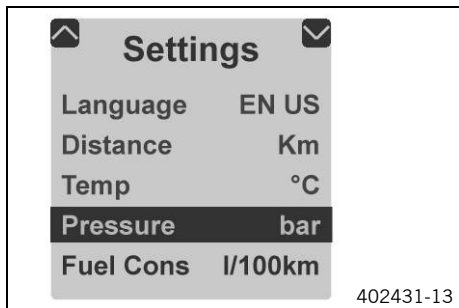

Condition

- The vehicle is stationary.
- Press the **UP** or **DOWN** button until the "**Settings**" menu appears on the matrix display. Pressing the **SET** button opens the menu.
- Press the **UP** or **DOWN** button until "**Pressure**" is highlighted in black on the matrix display. Pressing the **SET** button again sets the unit of measure.

Select "**bar**" or "**psi**" as the unit.

7.9.16 "Fuel Cons"

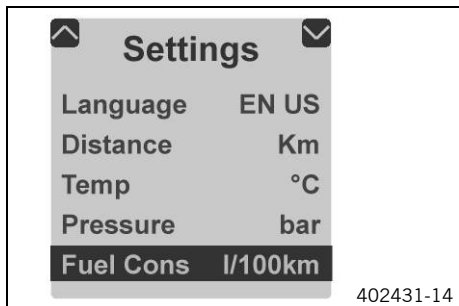

Condition

- The vehicle is stationary.
- Press the **UP** or **DOWN** button until the "**Settings**" menu appears on the matrix display. Pressing the **SET** button opens the menu.
- Press the **UP** or **DOWN** button until "**Fuel Cons**" is highlighted in black on the matrix display. Pressing the **SET** button again sets the unit of measure.

Select one of the available consumption displays.

7.9.17 "Clock/Date"

Clock/Date	
Hour	12
Minute	0
Day	1
Month	1
Year	2015

M00925-01

Condition

- The vehicle is stationary.
- Press the **UP** or **DOWN** button until the **"Settings"** menu appears on the matrix display. Pressing the **SET** button opens the menu.
- Press the **UP** or **DOWN** button until **"Clock/Date"** is highlighted in black on the matrix display. Pressing the **SET** button again opens the menu.
- Use the **UP** or **DOWN** button to navigate through the menu. Use the **SET** button to set the time and date.

If the battery was removed, the time and date must be set in the matrix display.

7.9.18 "Shift Light"

Shift Light	
RPM1	8000
RPM2	8250
Shift Light	on

M00926-01

Condition

- The vehicle is stationary.
- Press the **UP** or **DOWN** button until the **"Settings"** menu appears on the matrix display. Pressing the **SET** button opens the menu.
- Press the **UP** or **DOWN** button until **"Shift Light"** is highlighted in black on the matrix display. Pressing the **SET** button again opens the menu.
- Press the **UP** or **DOWN** button to select the function. Use the **SET** button to set the engine speed for the shift warning light.

When the engine speed reaches **"RPM 1"**, the shift warning light flashes.

When the engine speed reaches **"RPM 2"**, the shift warning light lights up continuously.

Switch the **"Shift Light"** function on or off.

7.9.19 "Heat Grip" (optional)

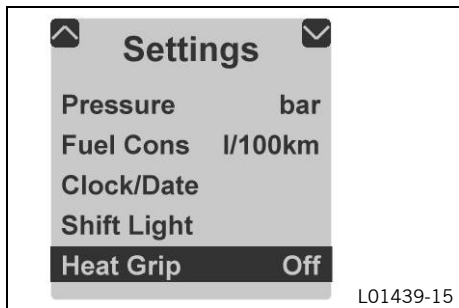

Condition

- The vehicle is stationary.
 - Press the **UP** or **DOWN** button until the "**Settings**" menu appears on the matrix display. Pressing the **SET** button opens the menu.
 - Press the **UP** or **DOWN** button until "**Heat Grip**" is highlighted in black on the matrix display. Pressing the **SET** button again switches the heated grips menu on or off.
- Switch the heated grips menu on and off.

7.9.20 "DRL"

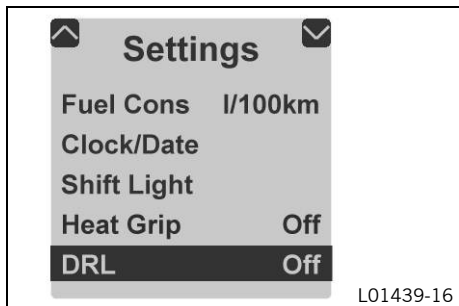

Condition

- The vehicle is stationary.
 - Press the **UP** or **DOWN** button until the "**Settings**" menu appears on the matrix display. Pressing the **SET** button opens the menu.
 - Press the **UP** or **DOWN** button until "**DRL**" is highlighted in black on the matrix display. Pressing the **SET** button again switches the daytime running light on or off.
- Switch the daytime running light on or off.



Info

Note the legal regulations regarding the daytime running light.

8.1 Handlebar position

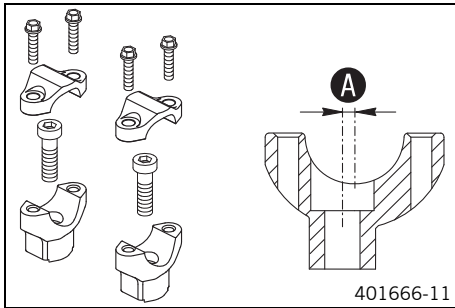

The holes on the handlebar support are placed at a distance of **A** from the center.

Hole distance A	3.5 mm (0.138 in)
------------------------	-------------------

The handlebar can be mounted in two different positions. In this way, the handlebar can be mounted in the position that is most comfortable for the rider.

8.2 Adjusting the handlebar position ↴

Warning
Danger of accidents Handlebar breakage.

- If the handlebar is bent or straightened it will cause material fatigue, and the handlebar can break. Always replace handlebar.

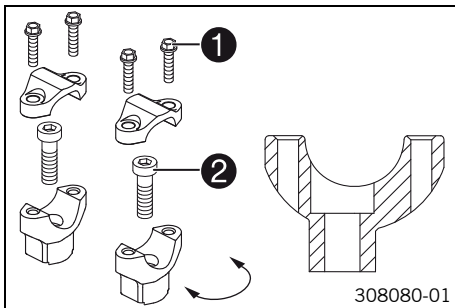

- Remove screws **1**. Remove the handlebar clamps. Remove the handlebar and lay it to one side.

i Info
 Cover the components to protect them against damage.
 Do not bend the cables and lines.

- Remove screws **2**. Take off the handlebar supports.
- Place the handlebar supports in the required position. Mount and tighten screws **2**.

Guideline

Screw, handlebar support	M10	40 Nm (29.5 lbf ft)	Loctite® 243™
--------------------------	-----	------------------------	----------------------



Info

Position the left and right handlebar supports evenly.

- Position the handlebar.



Info

Make sure the cables and wiring are positioned correctly.

- Position the handlebar clamps. Mount and evenly tighten screws **1**.

Guideline

Screw, handlebar clamp	M8	20 Nm (14.8 lbf ft)
------------------------	----	------------------------



Info

Make sure the gap widths are even.

8.3 Adjusting the wind shield

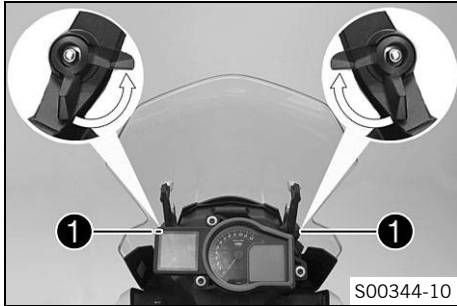

- Pull the clamping lever **1** in the direction of the arrow.
✓ The windshield is unlocked.

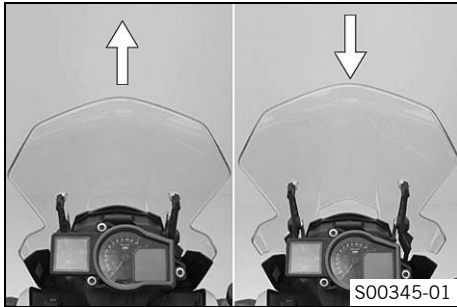

- Move the wind shield in the required position.

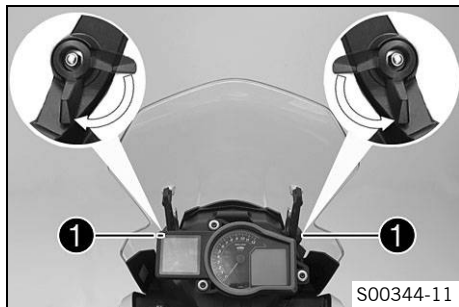

- Push the clamping lever ❶ in the direction of the arrow.
✓ The windshield is locked.

8.4 Adjusting basic position of clutch lever



- Adjust the basic setting of the clutch lever to your hand size by turning adjusting screw ❶.

i Info

Turn the adjusting screw clockwise to increase the distance between the clutch lever and the handlebar.
Turn the adjusting screw counterclockwise to decrease the distance between the clutch lever and the handlebar.
The range of adjustment is limited.
Turn the adjusting screw by hand only, and do not apply any force.
Do not make any adjustments while riding!

8.5 Adjusting the basic position of the hand brake lever

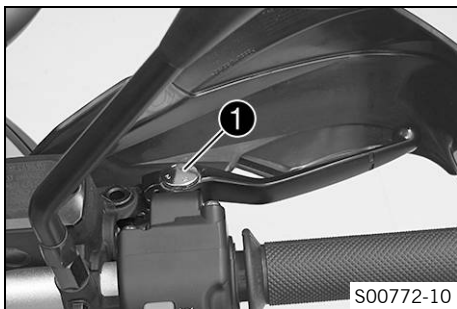

- Adjust the basic position of the hand brake lever to your hand size by turning adjusting wheel ①.

i Info

Push the hand brake lever forward and turn the adjusting wheel.
Do not make any adjustments while riding.

8.6 Rider footrests

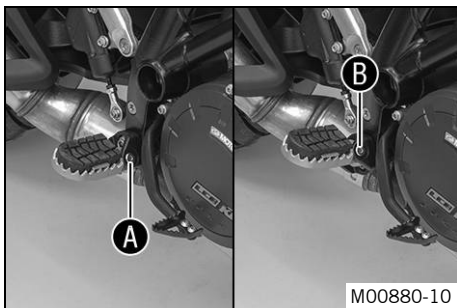

The rider footrests can be mounted in one of two positions.

Possible states

- Rider footrests, low ①
- Rider footrests, high ②

8.7 Adjusting the footrests ↗

i **Info**
The operations on the footrest brackets are the same for the left and right sides.

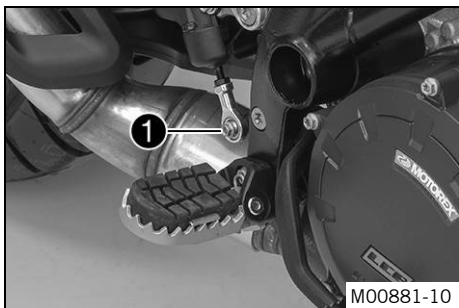

- Remove screw **1**.
- ✓ The foot brake lever swings up to the stop.

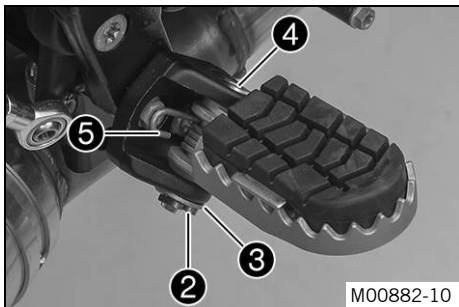

- Remove cotter pin **2** with washer **3**.
- Carefully remove the pin **4** of the rider footrest.

i **Info**
The spring is under high tension and can pop out when the pin is removed.

- Take off the rider footrest **5** with the spring.

8 ERGONOMICS

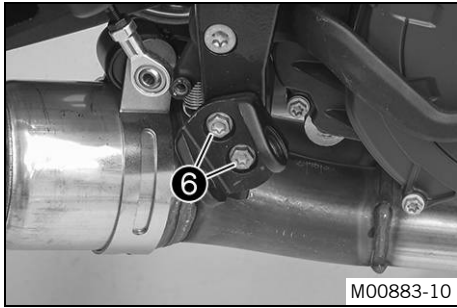

- Remove screws ⑥.

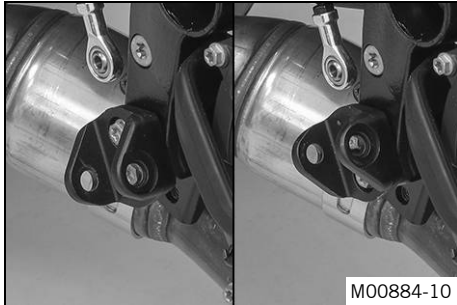

- Adjust the footrest bracket to the desired position.

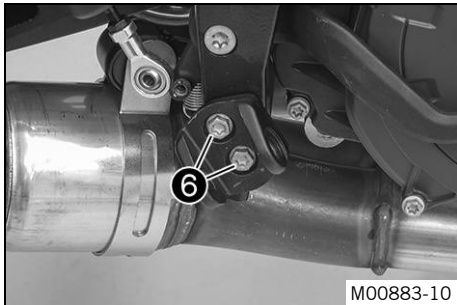

- Mount and tighten screws ⑥.

Guideline

Screw, front footrest bracket	M8	25 Nm (18.4 lbf ft)	Loctite® 243™
-------------------------------	----	------------------------	---------------

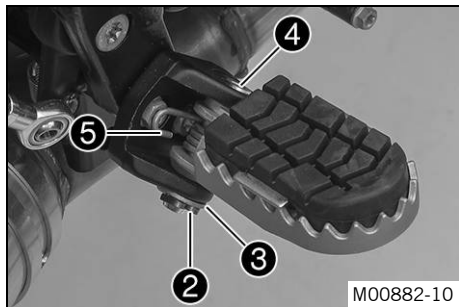

- Mount the rider footrest with spring ⑤ and pin ④.

Pliers for footrest spring (58429083000)

- Mount washer ③ and cotter pin ②.

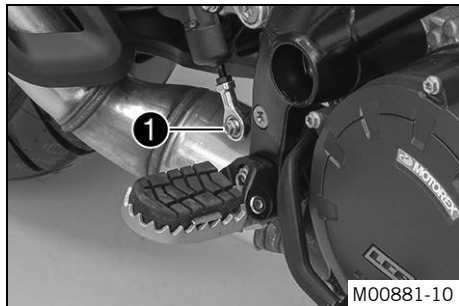

- Position the foot brake lever.
- Mount and tighten screw ①.

Guideline

Screw, ball joint of push rod on foot brake cylinder	M6	10 Nm (7.4 lbf ft)	Loctite® 243™
--	----	-----------------------	---------------

8.8 Checking the basic position of the shift lever



Info

When driving, the shift lever must not touch the driver's boot when in the basic position. When the shift lever keeps touching the boot, the transmission will be subject to an excessive load.

8 ERGONOMICS

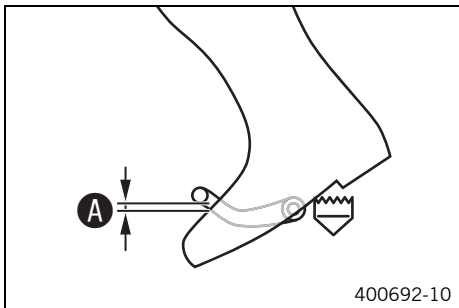

- Sit on the vehicle in the riding position and determine distance **A** between the upper edge of your boot and the shift lever.

Distance between shift lever and upper edge of boot	10... 20 mm (0.39... 0.79 in)
---	-------------------------------

- » If the distance does not meet specifications:
 - Adjust the basic position of the shift lever. ↘ (↖ p. 68)

8.9 Adjusting the basic position of the shift lever ↘

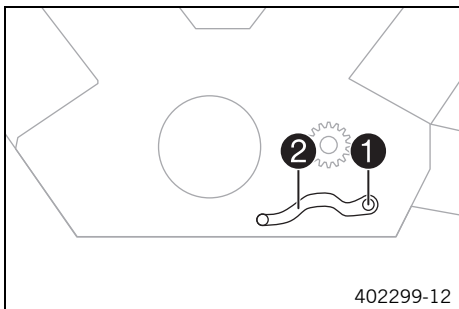

- Remove screw **1** with washers and take off shift lever **2**.

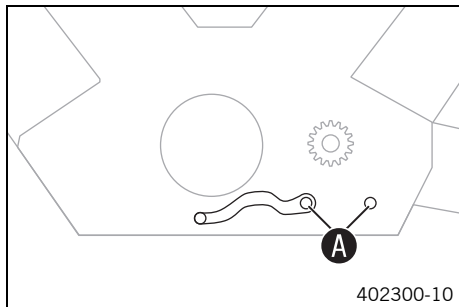

- Clean gear teeth **A** of the shift lever and shift shaft.
- Mount the shift lever on the shift shaft in the required position and engage the gearing.



Info

The range of adjustment is limited.
The shift lever must not come into contact with any other vehicle components during the shift procedure.

- Locate and tighten screw **1** with washers.

Guideline

Screw, shift lever	M6	18 Nm (13.3 lbf ft)	Loctite® 243™
--------------------	----	------------------------	---------------

8.10 Adjusting the basic position of the foot brake lever ↘

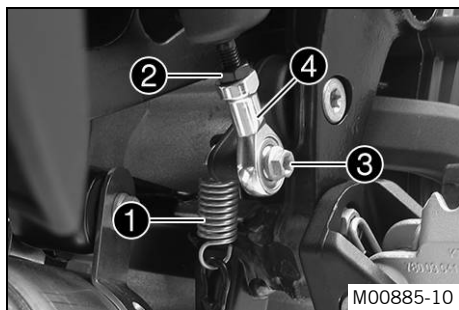

- Disconnect spring **1**.
- Loosen nut **2**.
- Remove screw **3**.
- To adjust the basic position of the foot brake lever to individual requirements, turn ball joint **4** accordingly.



Info

The range of adjustment is limited.
The screw must be screwed into the ball joint by at least 5 turns.

- Hold ball joint **4** and tighten nut **2**.

Guideline

Remaining chassis nuts	M6	10 Nm (7.4 lbf ft)
------------------------	----	--------------------

- Mount and tighten screw ③.

Guideline

Screw, ball joint of push rod on foot brake cylinder	M6	10 Nm (7.4 lbf ft)	Loctite® 243™
--	----	-----------------------	----------------------

- Attach spring ①.

9.1 Advice on first use



Danger

Danger of accidents Danger arising from the rider's judgement being impaired.

- Do not operate the vehicle while under the influence of alcohol, drugs and certain medications or physically or mentally impaired.



Warning

Risk of injury Missing or poor protective clothing presents an increased safety risk.

- Wear protective clothing (helmet, boots, gloves, pants and jacket with protectors) every time you ride the vehicle. Always wear protective clothing that is in good condition and meets the legal requirements.



Warning

Danger of crashing Poor vehicle handling due to different tire tread patterns on front and rear wheels.

- The front and rear wheels must be fitted with tires with similar tread patterns to prevent loss of control over the vehicle.



Warning

Danger of accidents Non-approved or non-recommended tires and wheels impact the handling characteristic.

- Only use tires/wheels approved by KTM with the corresponding speed index.



Warning

Danger of accidents Reduced road grip with new tires.

- New tires have a smooth rolling surface and therefore cannot provide full road grip. The entire rolling surface must be roughened in the first 200 kilometers (124.3 miles) by moderate riding at alternating angles. The full grip levels are not achieved until the tires have been run in.



Warning

Danger of accidents Failure of brake system.

- If the foot brake lever is not released, the brake linings drag continuously. The rear brake may fail due to overheating. Take your foot off the foot brake lever when you are not braking.



Info

When using your vehicle, remember that others may feel disturbed by excessive noise.

- Make sure that the pre-delivery inspection work has been carried out by an authorized KTM workshop.
 - ✓ You receive a delivery certificate and the Service and Warranty Booklet at vehicle handover.
- Before your first trip, read the entire Owner's Manual carefully.
- Get to know the controls.
- Adjust the motorcycle to your requirements, as described in the "Ergonomics" chapter.
- Get used to handling the motorcycle on a suitable piece of land before making a longer trip. Try also to ride as slowly as possible and in a standing position to get a better feeling for the motorcycle.
- Hold the handlebar firmly with both hands and keep your feet on the footrests when riding.
- Run the engine in.

9.2 Running in the engine

- During the running-in phase, do not exceed the specified engine speed.

Guideline

Maximum engine speed	
During the first: 1,000 km (620 mi)	6,500 rpm
After the first: 1,000 km (620 mi)	8,500 rpm

- Avoid fully opening the throttle!



Info

If the maximum engine speed is exceeded before the first service, the shift warning light flashes.

9.3 Loading the vehicle



Warning

Danger of accidents Unstable handling characteristics.

- Do not exceed the maximum permitted weight and axle loads. The overall weight consists of: motorcycle operational and with a full tank, driver and passenger with protective clothing and helmet, baggage.



Warning

Danger of accidents Unstable handling characteristics due to incorrect mounting of suitcase and/or tank rucksack.

- Mount and secure suitcase and tank rucksack according to the manufacturer's instructions.



Warning

Danger of accidents Unstable handling characteristics at high speed.

- Adapt your speed according to your payload. Ride more slowly if your motorcycle is loaded with cases or other baggage.
Maximum speed with luggage 150 km/h (93.2 mph)



Warning

Danger of accidents Risk of breakage of suitcase system.

- If you have fitted suitcases on your motorcycle, read the manufacturer's specifications concerning the maximum payload.





Warning

Danger of accidents Poor visibility for other road users due to slipped baggage.

- If the tail light is covered, you are less visible to traffic behind you, especially when it is dark. Check that your baggage is fixed properly at regular intervals.

9 PREPARING FOR USE

 **Warning**
Danger of accidents Changed handling characteristics and longer stopping distance with excessive payload.
– Adapt your speed according to your payload.

 **Warning**
Danger of accidents Unstable handling characteristics due to slipped baggage.
– Check the way your baggage is fixed regularly.

 **Warning**
Danger of burns A hot exhaust system can burn baggage.
– Fasten your baggage in such a way that it cannot be burned or singed by the hot exhaust system.

-
- If you are carrying baggage, make sure it is fixed firmly as close as possible to the center of the vehicle and ensure even weight distribution between the front and rear wheels.
 - Do not exceed the maximum permitted total weight and the axle loads.

Guideline

Maximum permissible total weight	440 kg (970 lb.)
Maximum permissible front axle load	159 kg (351 lb.)
Maximum permissible rear axle load	281 kg (619 lb.)

10.1 Checks and maintenance measures when preparing for use



Info

Before every trip, check the condition of the vehicle and ensure that it is roadworthy. The vehicle must be in perfect technical condition when it is being operated.

- Check the engine oil level. (☞ p. 179)
- Check the brake fluid level of the front brake. (☞ p. 127)
- Check the rear brake fluid level. (☞ p. 131)
- Check the front brake linings. (☞ p. 130)
- Check the rear brake linings. (☞ p. 133)
- Check that the brake system is functioning properly.
- Check the coolant level in the compensating tank. (☞ p. 174)
- Check the chain for dirt. (☞ p. 98)
- Check the chain tension. (☞ p. 99)
- Check the tire condition. (☞ p. 147)
- Check the tire air pressure. (☞ p. 148)
- Check the settings of all controls and ensure that they can be operated smoothly.
- Check that the electrical equipment is functioning properly.
- Check that luggage is properly secured.
- Check the setting of the rear mirror.
- Check the fuel level.

10.2 Starting

 **Danger**
Danger of poisoning Exhaust gases are toxic and inhaling them may result in unconsciousness and/or death.

- When running the engine, always make sure there is sufficient ventilation, and do not start or run the engine in an enclosed space without an effective exhaust extraction system.

 **Caution**
Danger of accidents If the vehicle is operated with a discharged battery or without a battery, electronic components and safety equipment may be damaged.



- Never operate the vehicle with a discharged battery or without a battery.

Note

Engine failure High engine speeds in cold engines have a negative effect on the service life of the engine.

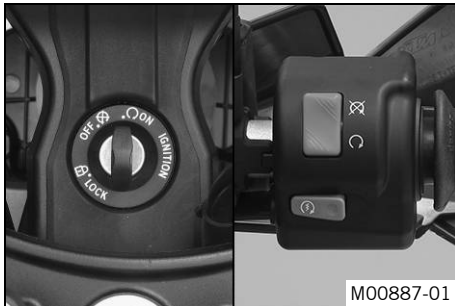
- Always warm up the engine at low engine speeds.



- Press the emergency OFF switch to the position **ON** .
- Switch on the ignition by turning the black ignition key to the position **ON** .
- ✓ After you switch on the ignition, you can hear the fuel pump working for about two seconds. The function check of the combination instrument is run at the same time.
- ✓ The ABS lamp lights up and goes back out after starting off.
- Shift the transmission to idle **N**.
- ✓ The green idling speed indicator lamp **N** lights up.



- Press the electric starter button (⚡).

i Info

Do not press the electric starter button until the combination instrument function check is finished.

When starting, **DO NOT** open the throttle. If you open the throttle during the starting procedure, fuel is not injected by the engine management system and the engine cannot start.

Press the electric starter button (⚡) for at most 5 seconds. Wait for a least 5 seconds before trying again.

This motorcycle is equipped with a safety starting system. You can only start the engine if the transmission is in neutral or if the clutch lever is pulled when a gear is engaged. If the side stand is folded out and you shift into gear, the engine stops.

- Remove the motorcycle from the side stand.

10.3 Starting off

- Pull the clutch lever, engage 1st gear, release the clutch lever slowly and simultaneously open the throttle carefully.

10.4 Shifting, riding



Warning

Danger of accidents Abrupt load alterations can cause the vehicle to get out of control.

- Avoid abrupt load alterations and sudden braking actions, and adapt your speed to the road conditions.



Warning

Danger of accidents If you change down at high engine speed, the rear wheel can lock up.

- Do not change into a low gear at high engine speed. The engine races and the rear wheel can lock up.



Warning

Danger of accidents Malfunctions caused by incorrect ignition key position.

- Do not change the ignition key position during a journey.



Warning

Danger of accidents Distraction from traffic activity by adjustments to the vehicle.

- Make all adjustments when the vehicle is at a standstill.



Warning

Risk of injury Falling off of the passenger.

- The passenger must be seated properly on the passenger seat and hold on to the front rider or the grab handles. The feet must be positioned on the passenger footrests. Note the regulations governing the minimum age of passengers.



Warning

Danger of accidents Danger of accidents caused by dangerous driving.

- Comply with traffic regulations and ride defensively and foresightedly to detect sources of danger early on.



Warning

Danger of accidents Reduced road grip with cold tires.

- On every journey, take the first miles carefully at moderate speed until the tires reach operating temperature and optimal road grip is ensured.



Warning

Danger of accidents Reduced road grip with new tires.

- New tires have a smooth rolling surface and therefore cannot provide full road grip. The entire rolling surface must be roughened in the first 200 kilometers (124.3 miles) by moderate riding at alternating angles. The full grip levels are not achieved until the tires have been run in.



Warning

Danger of accidents Unstable handling characteristics.

- Do not exceed the maximum permitted weight and axle loads. The overall weight consists of: motorcycle operational and with a full tank, driver and passenger with protective clothing and helmet, baggage.



Warning

Danger of accidents Unstable handling characteristics due to slipped baggage.

- Check the way your baggage is fixed regularly.



Warning

Danger of accidents Lack of roadworthiness.

- After a fall, check the vehicle as usual before preparing for use.

Note

Engine failure Unfiltered intake air has a negative effect on the service life of the engine.

- Never operate the vehicle without an air filter as dust and dirt will enter the engine and lead to increased wear.

Note

Engine failure Overheating of engine.

- If the coolant temperature warning lamp lights up, stop and switch off the engine. Allow the engine to cool down and check the coolant level in the radiator, and top up if necessary. If you continue with the coolant temperature warning lamp alight, you may have engine failure.



Info

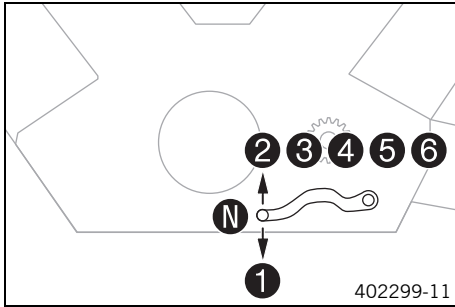

If you hear unusual noises while riding, stop immediately, switch off the engine and contact an authorized KTM workshop.



- When conditions allow (incline, road situation, etc.), you can shift into a higher gear.
- Release the throttle while simultaneously pulling the clutch lever, shift into the next gear, release the clutch lever, and open the throttle.

i **Info**

You can see the positions of the 6 forward gears in the figure. The idle position is between the first and second gears. First gear is used for starting off or for steep inclines.

-
- After reaching maximum speed by fully opening the throttle grip, turn the throttle back so it is $\frac{3}{4}$ open. This will barely reduce the speed but fuel consumption will be considerably lower.
 - Accelerate only up to a speed suitable for the road surface and weather conditions. Particularly in bends, do not shift, and accelerate very carefully.
 - To shift down, brake if necessary and close the throttle at the same time.
 - Pull the clutch lever and shift into a lower gear, release the clutch lever slowly, and open the throttle or shift again.
 - If the engine stalls (e.g. at a crossroads), just pull the clutch lever and press the electric starter button. You do not have to shift into neutral.
 - Switch off the engine if you expect to be standing for a long time.
 - If the oil pressure warning lamp  lights up during a trip, stop immediately and switch off the engine. Contact an authorized KTM workshop.
 - If the engine warning lamp  lights up during a trip, please contact an authorized KTM workshop as soon as possible.

i **Info**

From the flash rhythm you can deduce a two-digit number, the so-called blink code. The blink code tells you which component is affected by a malfunction.

-
- If the general warning lamp  lights up during a trip, the matrix display shows a message for 10 seconds.



Info

Very important messages are stored in the **"Warning"** menu.

- If the icy road symbol ❄ appears in the combination instrument, the roads may be icy. Adjust your speed to the road conditions.

10.5 Applying the brakes



Warning

Danger of accidents Reduced braking efficiency due to a wet or dirty brake system.

- Clean or dry a dirty or wet brake system by riding and braking gently.



Warning

Danger of accidents Reduced braking efficiency caused by spongy pressure point of front or rear brake.

- Check the brake system and do not continue riding. (Your authorized KTM workshop will be glad to help.)



Warning

Danger of accidents Failure of brake system.

- If the foot brake lever is not released, the brake linings drag continuously. The rear brake may fail due to overheating. Take your foot off the foot brake lever when you are not braking.



Warning

Danger of accidents Longer stopping distance due to higher overall weight.

- Take the longer stopping distance into account when carrying a passenger and baggage.



Warning

Danger of accidents Delayed brake action on salted roads.

- There may be salt deposits on the brake discs. In order to restore the normal braking efficiency, you will need to remove the deposits from the discs by carefully applying the brakes.



Warning

Danger of accidents Greater stopping distance due to ABS.

- Braking should be appropriate to the driving situation and the road conditions.



Warning

Danger of accidents Very forceful braking can cause the wheels to block.

- ABS must be switched on to be effective.



Warning

Danger of accidents Vehicle rollover

- It is not always possible to prevent vehicle rollover in extreme riding situations (e. g. luggage loaded with a high center of gravity, varying road surfaces, steep descents, full braking without disengaging the gear). Adapt your riding style to the road conditions and your driving ability.

-
- When braking, release the throttle and apply the front and rear brakes at the same time.



Info

When the ABS is enabled, you can achieve maximum braking power even on low grip surfaces such as sandy, wet, or slippery terrain without locking of the wheels.



Warning

Danger of accidents Locking of the wheels due to braking action of the engine.

- Pull the clutch during emergency braking, full brake application and when braking on a slippery surface.



Warning

Danger of accidents Road grip is reduced when braking with the motorcycle at an angle or on a laterally inclined surface.

- Braking should be completed before you enter into a bend.

-
- Braking should always be completed before you go into a bend. Change down to a lower gear appropriate to your road speed.

- On long downhill stretches, use the braking effect of the engine. Change down one or two gears, but do not over-rev the engine. In this way, you have to brake far less and the brakes do not overheat.

10.6 Stopping, parking



Warning

Risk of misappropriation Usage by unauthorized persons.

- Never leave the vehicle unattended while the engine is running. Secure the vehicle against use by unauthorized persons. If you leave the vehicle, lock the steering and remove the ignition key.



Warning

Danger of burns Some vehicle components become very hot when the vehicle is operated.

- Do not touch hot components such as exhaust system, radiator, engine, shock absorber, and the brake system. Allow these components to cool down before starting work on them.

Note

Material damage The vehicle may be damaged by incorrect procedure when parking.

Significant damage may be caused if the vehicle rolls away or falls over.

The components for parking the vehicle are designed only for the weight of the vehicle.



- Park the vehicle on a firm and level surface.
- Ensure that nobody sits on the vehicle when the vehicle is parked on a stand.

Note

Fire hazard Some vehicle components become very hot when the vehicle is operated.

- Do not park the vehicle near flammable or explosive substances. Do not place objects on the vehicle while it is still warm from being run. Always let the vehicle cool first.



-
- Apply the brakes on the motorcycle.

- Shift the transmission to idle .
 - Switch off the ignition by turning the black ignition key to the position **OFF** .
-



Info

If the engine is switched off with the emergency OFF switch and the ignition remains switched on at the ignition lock, power continues to flow to most power consumers. This discharges the battery. You should therefore always switch off the engine with the ignition key – the emergency OFF switch is intended for emergencies only.

- Park the motorcycle on a firm surface.
- Swing the side stand forward with your foot as far as it will go and lean the vehicle on it.
- Lock the steering by turning the handlebar to the left, pressing the black ignition key down in the position **OFF**  and turning it to the position **LOCK** . To make the steering lock engage more easily, move the handlebar a little to the left and right. Remove the black ignition key.

10.7 Transport

Note

Danger of damage The parked vehicle may roll away or fall over.

- Always place the vehicle on a firm and even surface.

Note

Fire hazard Some vehicle components become very hot when the vehicle is operated.

- Do not park the vehicle near flammable or explosive substances. Do not place objects on the vehicle while it is still warm from being run. Always let the vehicle cool first.
-

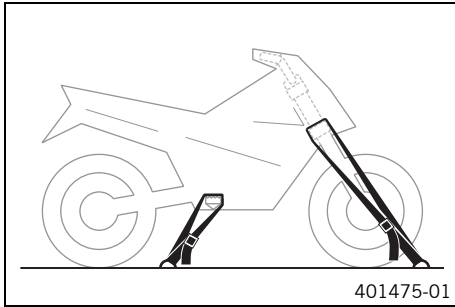

- Switch off the engine.
- Use tension belts or other suitable devices to secure the motorcycle against accidents or falling over.

10.8 Refueling



Danger

Fire hazard Fuel is highly flammable.

- Never refuel the vehicle near open flames or burning cigarettes, and always switch off the engine first. Be careful that no fuel is spilt, especially on hot vehicle components. Clean up spilt fuel immediately.
- The fuel in the fuel tank expands when warm and may emerge if overfilled. Follow the instructions on refueling.



Warning

Danger of poisoning Fuel is poisonous and a health hazard.

- Fuel must not come into contact with the skin, eyes, or clothing. Do not breathe in the fuel vapors. If contact occurs with the eyes, rinse with water immediately and contact a physician. Immediately clean contaminated areas on the skin with soap and water. If fuel is swallowed, contact a physician immediately. Change clothing that is contaminated with fuel.

Note

Material damage Premature clogging of the fuel filter.

- In some countries and regions, the available fuel quality and cleanliness may not be sufficient. This will result in problems with the fuel system. (Your authorized KTM workshop will be glad to help.)

10 RIDING INSTRUCTIONS

- Only refuel with clean fuel that meets the specified standards.



Warning

Environmental hazard Improper handling of fuel is a danger to the environment.

- Do not allow fuel to get into the ground water, the ground, or the sewage system.

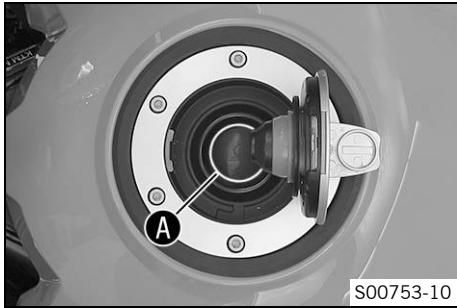

- Switch off the engine.
- Open the filler cap. (☛ p. 33)
- Fill the fuel tank with fuel up to the lower edge **A** of the filler neck.

Total fuel tank capacity, approx.	23 l (6.1 US gal)	Super unleaded (ROZ 95/RON 95/PON 91) (☛ p. 210)
-----------------------------------	-------------------	--















- Close the filler cap. (☛ p. 35)

11 SERVICE SCHEDULE

11.1 Additional information

Any further work that results from the required work or from the recommended work must be ordered separately and can be invoiced separately.

11.2 Required work

	Every two years	Every year	Every 30,000 km (18,600 mi)	Every 15,000 km (9,300 mi)	After 1,000 km (620 mi)
Read out the trouble code memory using the KTM diagnostics tool. 	○	●	●	●	●
Check the fuel pressure. 		●	●	●	●
Check the functioning of the electrical equipment.	○	●	●	●	●
Change the engine oil and oil filter and clean the oil screens.  ( p. 180)	○	●	●	●	●
Check the brake discs. ( p. 126)	○	●	●	●	●
Check the front brake linings. ( p. 130)	○	●	●	●	●
Check the rear brake linings. ( p. 133)	○	●	●	●	●
Check the tire condition. ( p. 147)	○	●	●	●	●
Check the tire air pressure. ( p. 148)	○	●	●	●	●
Check the rear brake fluid level. ( p. 131)	○	●	●	●	
Check the shock absorber and fork for leaks. Perform a fork service and shock absorber service as needed and depending on how the vehicle will be used. 	○	●	●	●	●
Clean the dust boots of the fork legs.  ( p. 118)		●	●		
Check the chain, rear sprocket, and engine sprocket. ( p. 102)		●	●	●	●
Check the chain tension. ( p. 99)	○	●	●	●	●

11 SERVICE SCHEDULE

	Every two years				
	Every year				
	Every 30,000 km (18,600 mi)				
	Every 15,000 km (9,300 mi)				
	After 1,000 km (620 mi)				
Check the brake lines for damage and leakage. 🛠️	○	●	●	●	●
Check the brake fluid level of the front brake. (🔧 p. 127)	○	●	●	●	
Check the coolant level in the compensating tank. (🔧 p. 174)	○	●	●	●	●
Check that the radiator fan is functioning properly. 🛠️	○	●	●	●	●
Change the air filter, clean the air filter box. 🛠️		●	●		
Check the cables for damage and routing without sharp bends. (fuel tank removed) 🛠️		●	●	●	●
Change the spark plugs (air filter removed). 🛠️			●		
Check the valve clearance (air filter and spark plugs removed). 🛠️			●		
Change the SAS membrane. 🛠️			●		
Change the front brake fluid. 🛠️					●
Change the rear brake fluid. 🛠️					●
Check the play of the steering head bearing. (🔧 p. 106)	○	●	●	●	●
Check the headlight setting. (🔧 p. 167)	○	●	●		
Final check: Check the vehicle for roadworthiness and take a test ride. 🛠️	○	●	●	●	●
Read out the error memory after the test ride using the KTM diagnostics tool. 🛠️	○	●	●	●	●
Check the CO adjustment using the KTM diagnostics tool. 🛠️	○	●	●		
Reset the service display using the KTM diagnostic tool. 🛠️	○	●	●	●	●
Make the service entry in the KTM Dealer.net and in the Service and Warranty Booklet. 🛠️	○	●	●	●	●

○ One-time interval

11 SERVICE SCHEDULE

- Periodic interval

11.3 Recommended work

	Every four years				
	Every two years				
	Every year				
	Every 15,000 km (9,300 mi)				
	After 1,000 km (620 mi)				
Check/clean the oil nozzle for clutch lubrication. 🛠️	○	●			
Check the swingarm bearing for play.		●			
Check the wheel bearing for play.		●			
Grease all moving parts (e.g., side stand, hand lever, chain, ...) and check for smooth operation. 🛠️	○	●	●	●	●
Check all hoses (e.g. fuel, cooling, bleeder, drainage, etc.) and sleeves for cracking, leaks, and incorrect routing. 🛠️		●	●	●	●
Check the antifreeze. 🛠️	○	●	●	●	●
Check/correct the fluid level of the hydraulic clutch. (👉 p. 105)		●	●		
Change the hydraulic clutch fluid. 🛠️				●	●
Check the screws and nuts for tightness. 🛠️	○	●	●	●	●
Change the coolant. 🛠️					●

- One-time interval
- Periodic interval

12.1 Adjusting the rebound damping of the shock absorber



Caution

Danger of accidents Disassembly of pressurized parts can lead to injury.

- The shock absorber is filled with high density nitrogen. Adhere to the description provided. (Your authorized KTM workshop will be glad to help.)

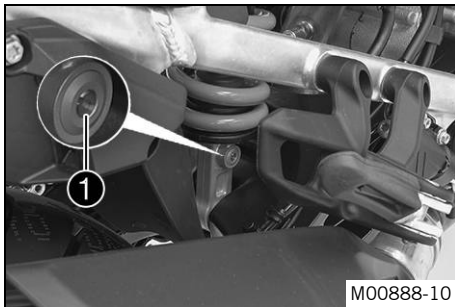

- Turn adjusting screw ❶ clockwise up to the last perceptible click.
- Turn counterclockwise by the number of clicks corresponding to the shock absorber type.

Guideline

Rebound damping	
Standard	12 clicks



Info

Turn clockwise to increase damping; turn counterclockwise to reduce damping.

12.2 Adjusting the spring preload of the shock absorber



Caution

Danger of accidents Disassembly of pressurized parts can lead to injury.

- The shock absorber is filled with high density nitrogen. Adhere to the description provided. (Your authorized KTM workshop will be glad to help.)

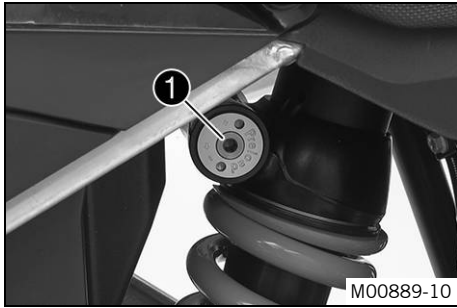

- Turn adjusting screw ❶ counterclockwise all the way.
- Turn it clockwise by the number of turns corresponding to the shock absorber type and use.

Guideline

Spring preload	
Standard	2 turns

i Info Turn clockwise to increase the spring preload; turn counterclockwise to reduce the spring preload.

13 SERVICE WORK ON THE CHASSIS

13.1 Lifting the motorcycle with the rear lifting gear

Note

Danger of damage The parked vehicle may roll away or fall over.

- Always place the vehicle on a firm and even surface.



- Mount lifting bushings on the swingarm.
- Place the adapter into the rear lifting gear.

Adapter (61029055120)

Rear wheel stand (61029055400)

- Place the motorcycle vertically, use the adapters to direct the lifting gear towards the swingarm and lift the motorcycle.

13.2 Removing the rear of motorcycle from the lifting gear

Note

Danger of damage The parked vehicle may roll away or fall over.

- Always place the vehicle on a firm and even surface.

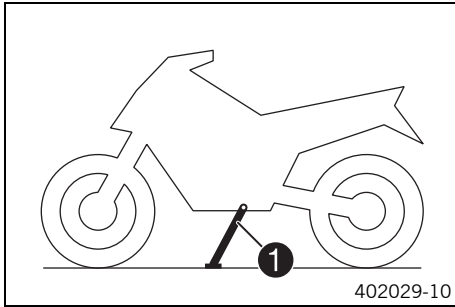

- Secure the motorcycle against falling over.
- Remove the rear lifting gear and lean the motorcycle on the side stand ❶.
- Remove the lifting bushings from the swingarm.

13.3 Lifting the motorcycle with the front lifting gear

Note

Danger of damage The parked vehicle may roll away or fall over.

- Always place the vehicle on a firm and even surface.

Preparatory work

- Lift the motorcycle with the rear lifting gear. (☛ p. 92)
- Remove the bottom triple clamp cover. (☛ p. 107)

13 SERVICE WORK ON THE CHASSIS



Main work

- Move the handlebar to the straight-ahead position.
- Attach the front lifting gear with the adapters on the steering stem.

Adapter (61029955620)

Front wheel stand (61029055500)

- Direct the front lifting gear towards the fork legs.



Info

Always raise the motorcycle at the rear first.

- Raise the motorcycle at the front.

13.4 Taking the motorcycle from the front lifting gear

Note

Danger of damage The parked vehicle may roll away or fall over.

- Always place the vehicle on a firm and even surface.



Main work

- Secure the motorcycle against falling over.
- Remove the front lifting gear.

Finishing work

- Install the bottom triple clamp cover. (👉 p. 108)

13.5 Raising the motorcycle with the work stand (inserted) 🛠️

Note

Danger of damage The parked vehicle may roll away or fall over.

- Always place the vehicle on a firm and even surface.

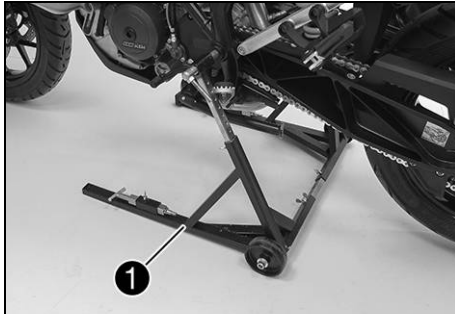

- Fold up the rider footrests and secure them.
- Allow the work stand ① with plastic bushing to engage in the opening of the swingarm pivot.

Work stand (62529055100)



Info

Set the work stand to an appropriate height and width.

- Raise the motorcycle.
- Check that the work stand is properly seated.

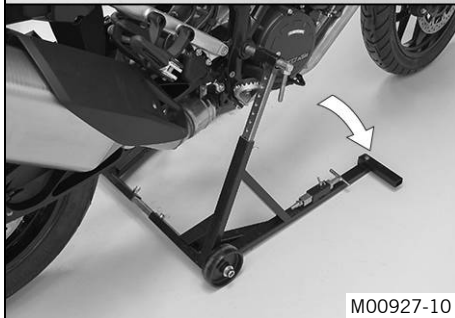

13.6 Removing the motorcycle from the work stand (inserted) ↴

Note

Danger of damage The parked vehicle may roll away or fall over.

- Always place the vehicle on a firm and even surface.

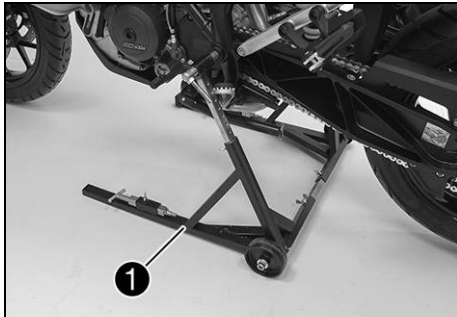

- Secure the motorcycle against falling over.
- Remove the special tool ❶.

Work stand (62529055100)

i Info

To avoid damaging components, lower the motorcycle slowly from the work stand.

The assistance of a second person can be useful.

- Lean the motorcycle on the side stand.
- Remove the fixing means on the rider footrests.

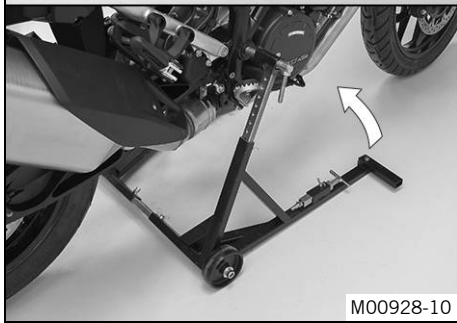

13.7 Removing the seat

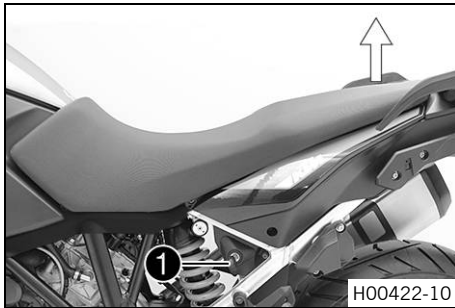

- Insert the ignition key in the seat lock **1** and turn it clockwise by 45°.
- Raise the rear of the seat, pull the seat back, and lift it off.
- Remove the ignition key.

13.8 Mounting the seat

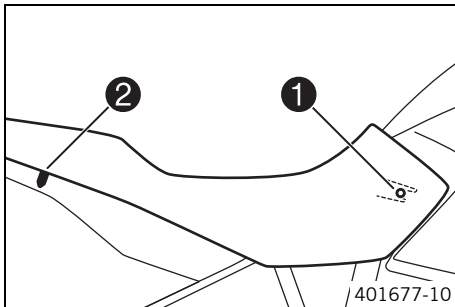

- Hook the catch **1** of the seat onto the fuel tank and lower the rear while pushing it forward.
- Insert the locking pin **2** into the lock housing and push down the rear of the seat until the locking pin engages with an audible click.
- Finally, check that the seat is correctly mounted.

13.9 Checking for chain dirt

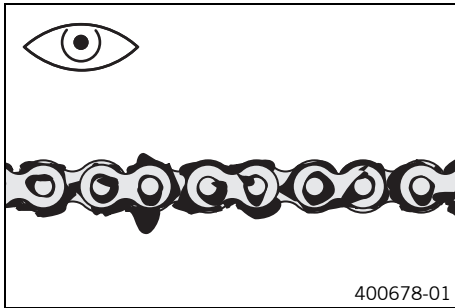

- Check the chain for coarse dirt accumulation.
 - » If the chain is very dirty:
 - Clean the chain. (☛ p. 98)

13.10 Cleaning the chain

-  **Warning**
Danger of accidents Oil or grease on the tires reduces their grip.
- Remove oil and grease with a suitable cleaning material.

-  **Warning**
Danger of accidents Reduced braking efficiency due to oil or grease on the brake discs.
- Always keep the brake discs free of oil and grease, and clean them with brake cleaner when necessary.

-  **Warning**
Environmental hazard Hazardous substances cause environmental damage.
- Oil, grease, filters, fuel, cleaners, brake fluid, etc., should be disposed of as stipulated in applicable regulations.



Info

The service life of the chain depends largely on its maintenance.

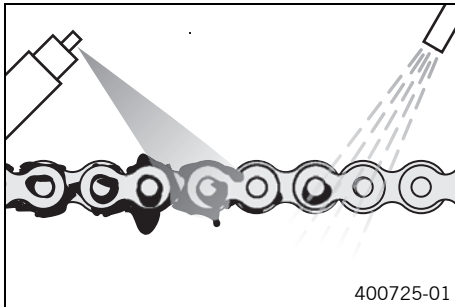

Preparatory work

- Lift the motorcycle with the rear lifting gear. (☛ p. 92)

Main work

- Clean the chain regularly.
- Rinse off loose dirt with a soft jet of water.
- Remove old grease remains with chain cleaner.

Chain cleaner (☛ p. 211)

- After drying, apply chain spray.

Chain lube for road use (☛ p. 211)

Finishing work

- Remove the rear of the motorcycle from the lifting gear. (☛ p. 92)

13.11 Checking the chain tension



Warning

Danger of accidents Danger caused by incorrect chain tension.

- If the chain is too taut, the components of the secondary power transmission (chain, engine sprocket, rear sprocket, bearings in the transmission and in the rear wheel) will be under additional load. In addition to premature wear, this can cause the chain or the countershaft of the transmission to break in extreme cases. If the chain is too loose, however, it may fall off the engine sprocket or rear sprocket and block the rear wheel or damage the engine. Ensure that the chain tension is correct and adjust it if necessary.

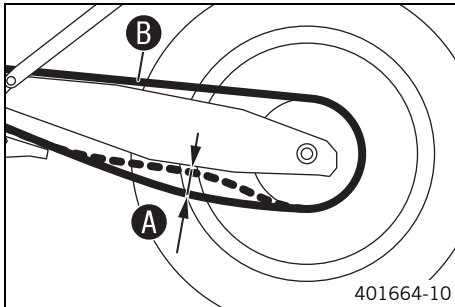

Preparatory work

- Lift the motorcycle with the rear lifting gear. (☛ p. 92)

Main work

- Shift the transmission to idle **N**.
- In the area in front of the chain guide, push the chain up and determine the chain tension **A**.

i Info

The upper part of the chain **B** must be taut.

Chain wear is not always even, so you should repeat this measurement at different chain positions.

Chain tension	40... 45 mm (1.57... 1.77 in)
---------------	-------------------------------

- » If the chain tension does not meet the specification:
 - Adjust the chain tension. (☛ p. 100)
- Remove the rear of the motorcycle from the lifting gear. (☛ p. 92)

13.12 Adjusting the chain tension



Warning

Danger of accidents Danger caused by incorrect chain tension.

- If the chain is too taut, the components of the secondary power transmission (chain, engine sprocket, rear sprocket, bearings in the transmission and in the rear wheel) will be under additional load. In addition to premature wear, this can cause the chain or the countershaft of the transmission to break in extreme cases. If the chain is too loose, however, it may fall off the engine sprocket or rear sprocket and block the rear wheel or damage the engine. Ensure that the chain tension is correct and adjust it if necessary.

Preparatory work

- Lift the motorcycle with the rear lifting gear. (☛ p. 92)

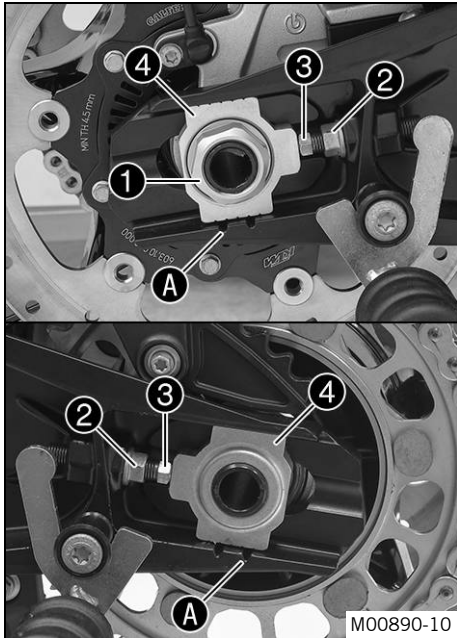

- Check the chain tension. (☛ p. 99)

Main work

- Loosen nut ❶.
- Loosen nuts ❷.
- Adjust the chain tension by turning the adjusting screws ❸ left and right.

Guideline

Chain tension	40... 45 mm (1.57... 1.77 in)
Turn the adjusting screws ❸ on the left and right so that the markings on the left and right chain adjusters ❹ are in the same position relative to the reference marks A. The rear wheel is then correctly aligned.	

Info

The upper part of the chain must be taut. Chain wear is not always even, so you should check the setting at different chain positions.

- Tighten nuts ❷.
- Make sure that chain adjusters ❹ are fitted correctly on adjusting screws ❸.
- Tighten nut ❶.

Guideline

Nut, rear wheel spindle	M25x1.5	90 Nm (66.4 lbf ft)	Thread greased
-------------------------	---------	------------------------	----------------

Info

Chain adjusters ❹ can be turned by 180°.

Finishing work

- Remove the rear of the motorcycle from the lifting gear. (☛ p. 92)

13.13 Checking the chain, rear sprocket, and engine sprocket

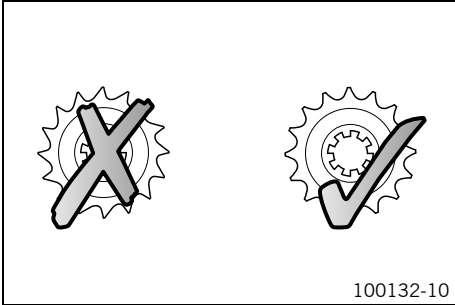

Preparatory work

- Lift the motorcycle with the rear lifting gear. (🔧 p. 92)

Main work

- Check the rear sprocket and engine sprocket for wear.
 - » If the rear sprocket and engine sprocket are worn:
 - Change the drivetrain kit. 🛠️

Info

The engine sprocket, rear sprocket, and chain should always be replaced together.

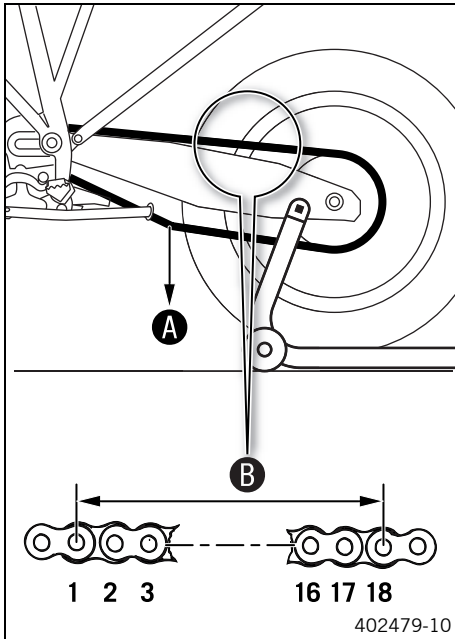

- Shift the transmission to idle **N**.
- Pull the lower chain section with the specified weight **A**.

Guideline

Weight, chain wear measurement	15 kg (33 lb.)
--------------------------------	----------------

- Measure the distance **B** of 18 chain rollers on the upper part of the chain.

i Info
Chain wear is not always even, so you should repeat this measurement at different chain positions.

Maximum distance B at the longest chain section	272 mm (10.71 in)
--	-------------------

- » If the distance **B** is greater than the specified measurement:
 - Change the drivetrain kit.

i Info
When the chain is replaced, the rear sprocket and engine sprocket should also be changed.
New chains wear out faster on old, worn sprockets.
For safety reasons, the chain has no chain joint.

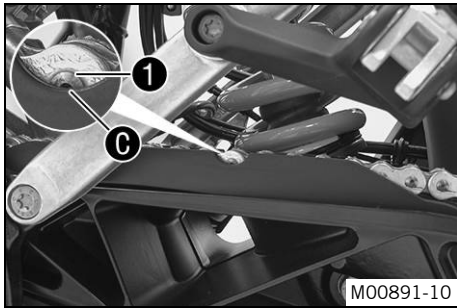

- Check the chain sliding guard for wear at the recess.

i Info

When the chain sliding guard is new, the rivets **1** are half visible at the bottom edge **C** of the recess.

- » When the rivets of the chain are no longer visible at the bottom edge of the recess of the chain sliding guard:
 - Change the chain sliding guard. 🛠️
- Check that the chain sliding guard is firmly seated.
 - » If the chain sliding guard is loose:
 - Tighten the screws on the chain sliding guard.

Guideline

Screw, chain sliding guard	M5	5 Nm (3.7 lbf ft)
----------------------------	----	-------------------

- Check the chain guide for wear.
 - » If the chain guide is worn:
 - Change the chain guide. 🛠️
- Check that the chain guide is firmly seated.
 - » If the chain guide is loose:
 - Tighten the screws on the chain guide.

Guideline

Screw, chain guide	M6	5 Nm (3.7 lbf ft)
--------------------	----	-------------------

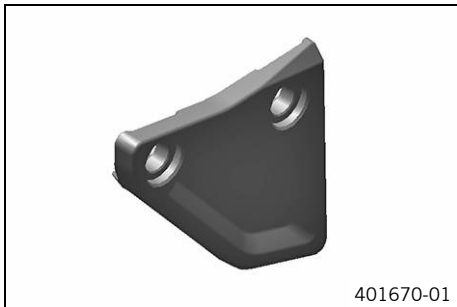

Finishing work

- Remove the rear of the motorcycle from the lifting gear. (🔧 p. 92)

13.14 Checking/correcting the fluid level of the hydraulic clutch



Warning

Skin irritation Brake fluid can cause skin irritation on contact.

- Avoid contact with skin and eyes, and keep out of the reach of children.
- Wear suitable protective clothing and goggles.
- If brake fluid comes into contact with the eyes, flush the eyes thoroughly with water and consult a physician immediately.



Warning

Environmental hazard Hazardous substances cause environmental damage.

- Oil, grease, filters, fuel, cleaners, brake fluid, etc., should be disposed of as stipulated in applicable regulations.



Info

The fluid level rises with increasing wear of the clutch facing discs.

Never use DOT 5 brake fluid! It is silicone-based and purple in color. Oil seals and clutch lines are not designed for DOT 5 brake fluid.

Avoid contact between brake fluid and painted parts. Brake fluid attacks paint!

Use only clean brake fluid from a sealed container.

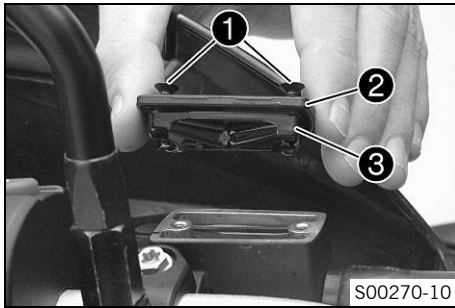

- Move the clutch fluid reservoir mounted on the handlebar to a horizontal position.
- Remove screws ①.
- Remove cover ② with membrane ③.
- Check the fluid level.

Fluid level below container rim	4 mm (0.16 in)
---------------------------------	----------------

» If the fluid level does not meet specifications:

- Correct the fluid level of the hydraulic clutch.

Brake fluid DOT 4 / DOT 5.1 (☛ p. 208)
--

- Position the cover with the membrane. Mount and tighten the screws.



Info

Clean up overflowed or spilled brake fluid immediately with water.

13.15 Checking the play of the steering head bearing



Warning

Danger of accidents Unstable vehicle handling from incorrect steering head bearing play.

- Adjust the steering head bearing play without delay. (Your authorized KTM workshop will be glad to help.)



Info

If the vehicle is operated for a lengthy period with play in the steering head bearing, the bearings and the bearing seats in the frame can become damaged over time.

Preparatory work

- Raise the motorcycle with the work stand (inserted). ☛ (☛ p. 95)

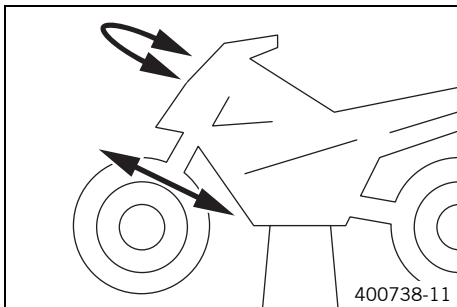

Main work

- Place a load on the rear of the vehicle.
 - ✓ The front wheel is not in contact with the ground.
- Move the handlebar to the straight-ahead position. Move the fork legs back and forth in the direction of travel.

Play should not be detectable on the steering head bearing.

- » If there is detectable play:
 - Adjust the steering head bearing play. 🛠️
- Move the handlebar back and forth over the entire steering range.

It must be possible to move the handlebar easily over the entire steering range. There should be no detectable detent positions.

- » If detent positions are detected:
 - Adjust the steering head bearing play. 🛠️
 - Check the steering head bearing and adjust if necessary.
- Remove the motorcycle from the work stand (inserted). 🛠️ (📄 p. 96)

13.16 Removing the bottom triple clamp cover

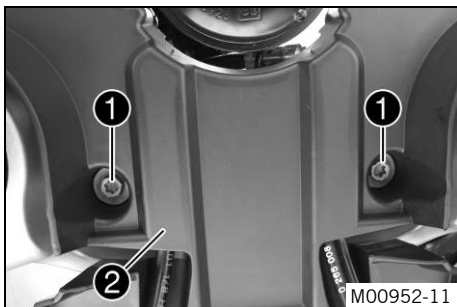

- Remove screws ①.
- Lower the triple clamp cover ② slightly.

13 SERVICE WORK ON THE CHASSIS

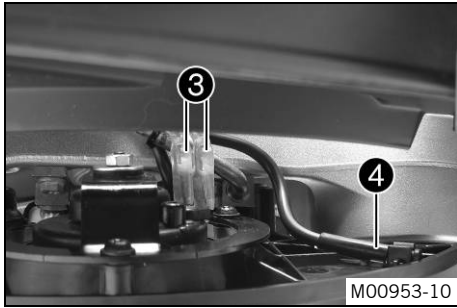

- Disconnect plugs ③ of the horn.
- Detach temperature sensor ④.
- Remove the triple clamp cover.

13.17 Installing the bottom triple clamp cover

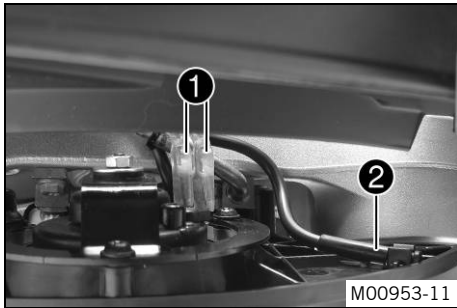

- Plug in connectors ① of the horn.
- Attach temperature sensor ②.

13 SERVICE WORK ON THE CHASSIS

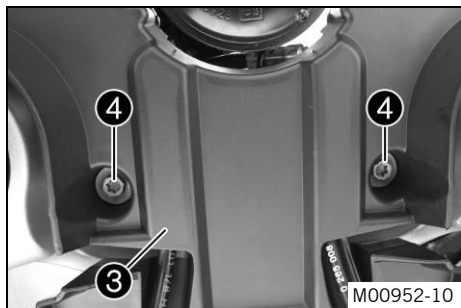

- Position the triple clamp cover ③.
- Mount and tighten screws ④.

Guideline

Remaining chassis screws	M6	10 Nm (7.4 lbf ft)
--------------------------	----	--------------------

13.18 Removing the front side cover

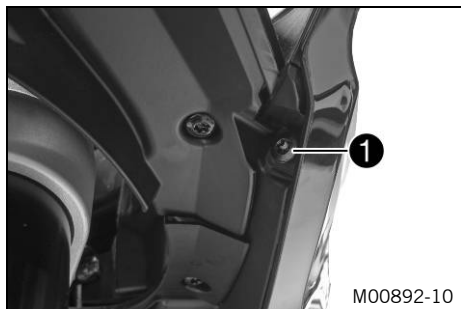

- Remove screw ①.

13 SERVICE WORK ON THE CHASSIS

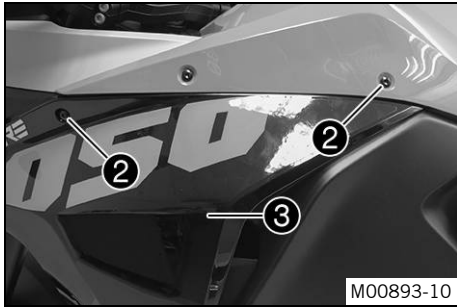

- Remove screws ②.
- Remove side cover ③.
- Repeat the operation on the opposite side.

13.19 Installing the front side cover



- Position the side cover in the ① area under the tank cover.

13 SERVICE WORK ON THE CHASSIS

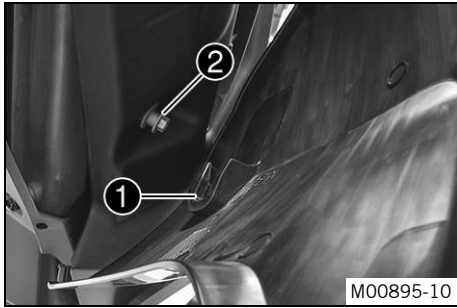

- Attach catch ① of the side cover to bracket ② and position on the fuel tank.

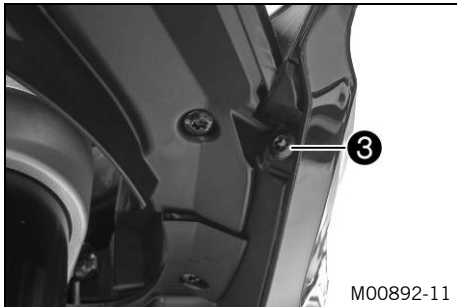

- Mount and tighten screw ③.

Guideline

Screw, cover part	M5	3.5 Nm (2.58 lbf ft)
-------------------	----	-------------------------

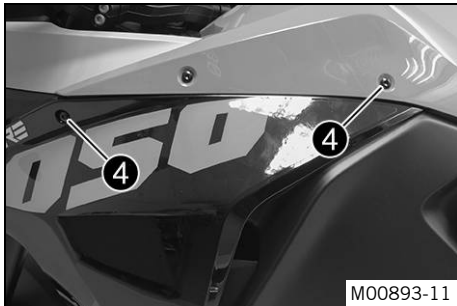

- Mount and tighten screws ④.

Guideline

Screw, cover part	M5	3.5 Nm (2.58 lbf ft)
-------------------	----	-------------------------

- Repeat the operation on the opposite side.

13.20 Removing the mask spoiler ↩

Preparatory work

- Remove the seat. (↩ p. 97)
- Remove the front side cover. (↩ p. 109)
- Remove the tank cover. (↩ p. 119)

Main work

- Remove screw ①.

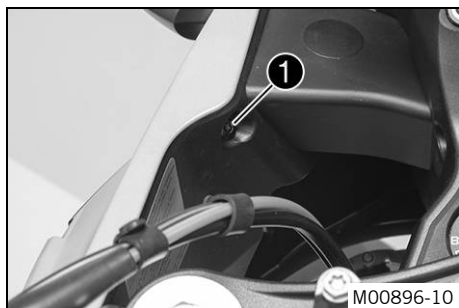

- Remove screw ②.



13 SERVICE WORK ON THE CHASSIS

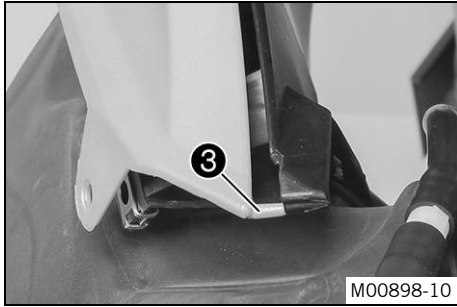

- Loosen holding lug ③ from the inside cover.

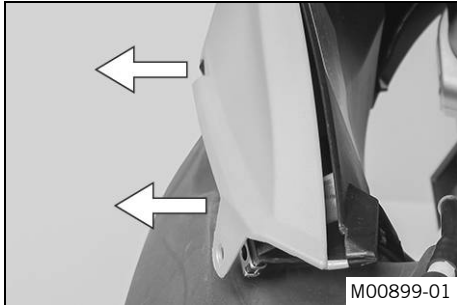

- Remove the mask spoiler laterally from the supports.

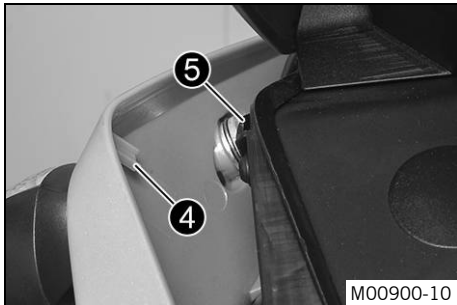

- Remove catch ④ upward from the bracket ⑤.



Info

Pay attention to the turn signal cable.

13 SERVICE WORK ON THE CHASSIS

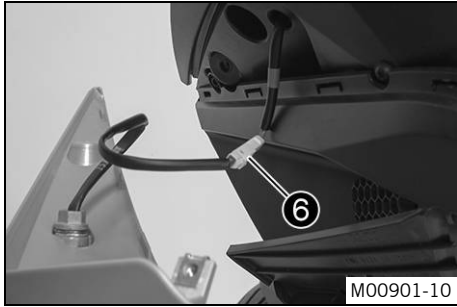

- Disconnect plug-in connector ⑥.
- Remove the mask spoiler with the turn signal.
- Repeat the operation on the opposite side.

13.21 Installing the mask spoiler ↩

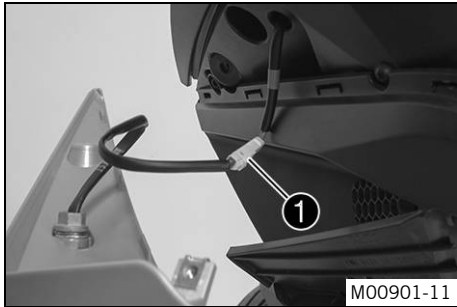

Main work

- Connect plug-in connector ①.

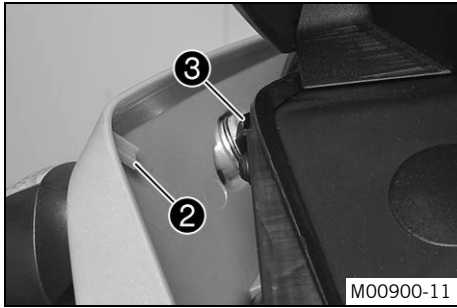

- Position the catch ② in the bracket ③.



Info

Ensure that the turn signal cable is placed correctly.

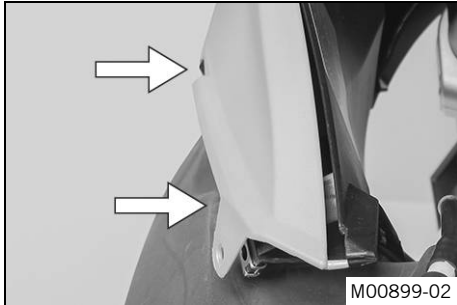

- Press the mask spoiler laterally into the supports.

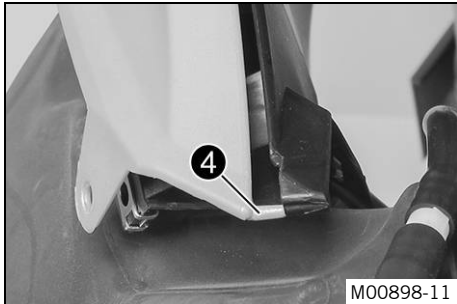

- Position the holding lug ④ in the drill hole.

13 SERVICE WORK ON THE CHASSIS



- Mount and tighten screw ⑤.

Guideline

Screw, mask spoiler	M5x17	3.5 Nm (2.58 lbf ft)
---------------------	-------	-------------------------

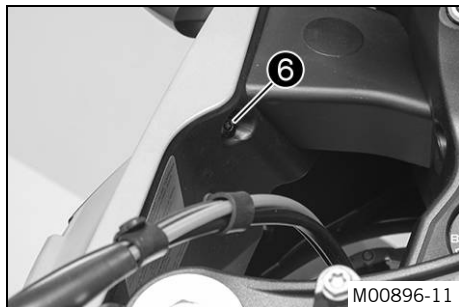

- Mount and tighten screw ⑥.

Guideline

Screw, mask spoiler	M5x17	3.5 Nm (2.58 lbf ft)
---------------------	-------	-------------------------

- Repeat the operation on the opposite side.

Finishing work

- Install the tank cover. (☛ p. 121)
- Install the front side cover. (☛ p. 110)
- Mount the seat. (☛ p. 97)

13.22 Removing the front fender

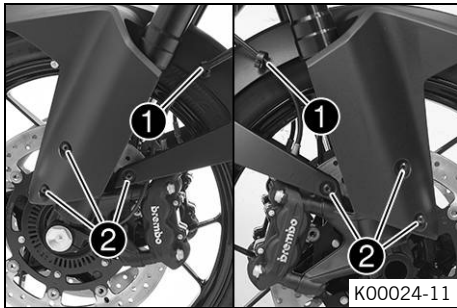

- Open holder ① and detach the brake lines and cable.
- Remove screws ②.
- Remove the fender in a forward direction.



Info

Pay attention to the brake lines and the cable.

13.23 Installing the front fender

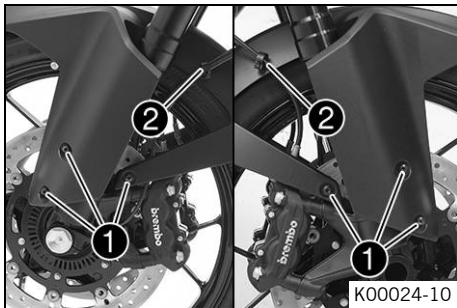

- Position the fender.



Info

Pay attention to the routing of the brake lines and the cable.

- Mount and tighten screws ①.

Guideline

Screw, fender	M5x12	3.5 Nm (2.58 lbf ft)
---------------	-------	-------------------------

- Insert the brake lines and cable in brackets ② and close the holder.

13.24 Cleaning the dust boots of the fork legs ↩

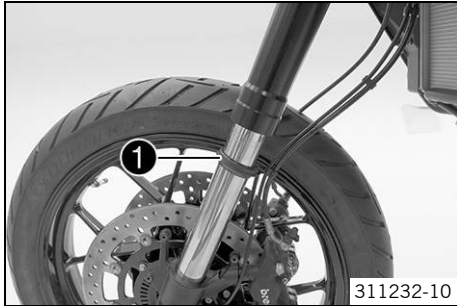

Preparatory work

- Remove the front fender. (↩ p. 117)

Main work

- Push dust boot ❶ of both fork legs downwards.

Info

The dust boots should remove dust and coarse dirt particles from the fork tubes. Over time, dirt can penetrate behind the dust boots. If this dirt is not removed, the oil seals behind can start to leak.

Warning

Danger of accidents Reduced braking efficiency due to oil or grease on the brake discs.

- Always keep the brake discs free of oil and grease, and clean them with brake cleaner when necessary.

- Clean and oil the dust boots and inner fork tube of both fork legs.

Universal oil spray (↩ p. 212)

- Press the dust boots back into their normal position.
- Remove excess oil.

Finishing work

- Install the front fender. (↩ p. 117)

13.25 Removing the tank cover

Preparatory work

- Remove the seat. (☛ p. 97)
- Remove the front side cover. (☛ p. 109)

Main work

- Remove screw ①.
- Remove screw ②.

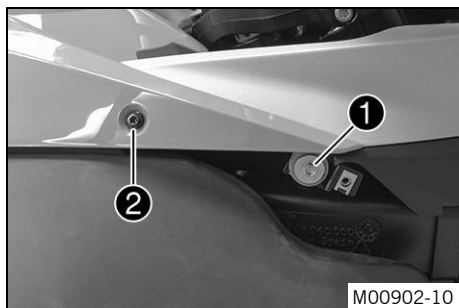

- Remove screw ③.
- Remove screw ④.

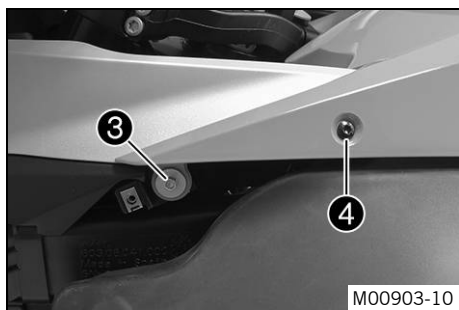

13 SERVICE WORK ON THE CHASSIS

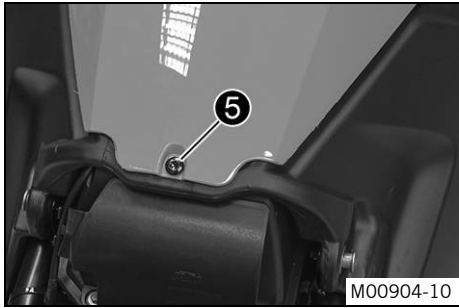

- Remove screw ⑤.



- Raise the tank cover at the rear and remove it in a forward direction.

13.26 Installing the tank cover

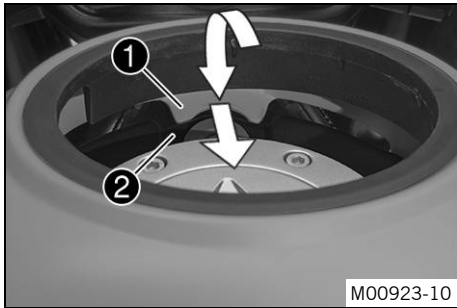

Main work

- Position the tank cover.
 - ✓ The catch ① engages under the tank ②.

Info

Pay attention to the sealing lip and the bleeder hose.

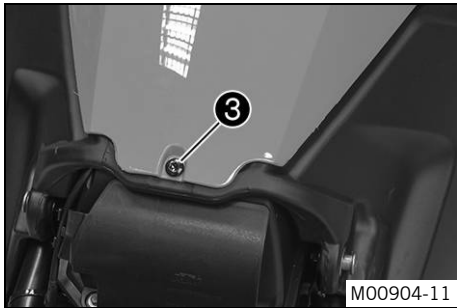

- Mount and tighten screw ③.

Guideline

Screw, cover part	M5	3.5 Nm (2.58 lbf ft)
-------------------	----	-------------------------

13 SERVICE WORK ON THE CHASSIS

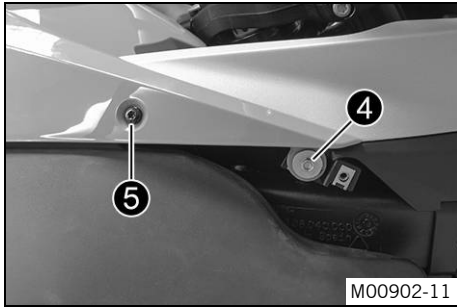

- Mount and tighten screw ④.

Guideline

Screw, cover part	M6	6 Nm (4.4 lbf ft)
-------------------	----	-------------------

- Mount and tighten screw ⑤.

Guideline

Screw, cover part	M5	3.5 Nm (2.58 lbf ft)
-------------------	----	-------------------------

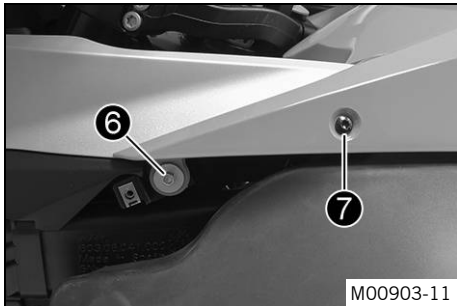

- Mount and tighten screw ⑥.

Guideline

Screw, cover part	M6	6 Nm (4.4 lbf ft)
-------------------	----	-------------------

- Mount and tighten screw ⑦.

Guideline

Screw, cover part	M5	3.5 Nm (2.58 lbf ft)
-------------------	----	-------------------------

Finishing work

- Install the front side cover. (☞ p. 110)
- Mount the seat. (☞ p. 97)

13.27 Removing the wind shield

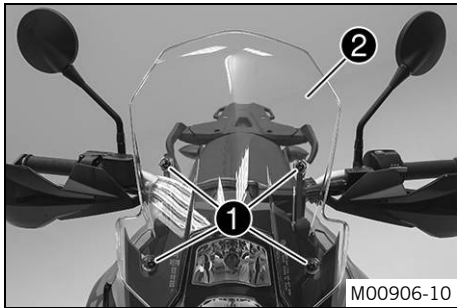

- Remove screws ❶ and wind shield ❷.

13.28 Installing the wind shield

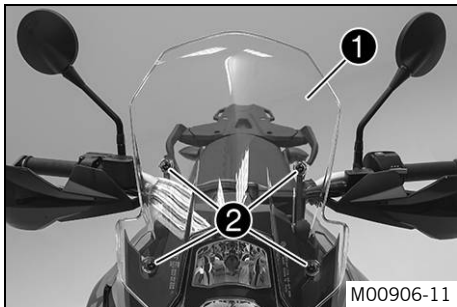

- Position wind shield ❶.
- Mount and tighten screws ❷.

Guideline

Screw, wind shield	M5	3.5 Nm (2.58 lbf ft)
--------------------	----	-------------------------

13.29 Removing the engine guard

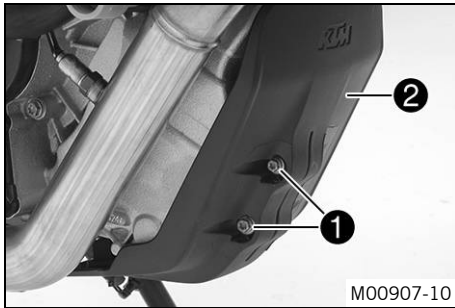

- Remove screws ① and engine guard ②.

13.30 Installing the engine guard

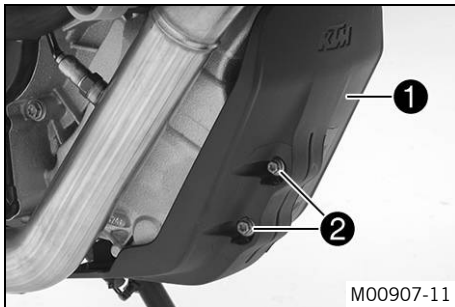

- Position engine guard ①. Mount and tighten screws ②.

Guideline

Screw, engine guard	M6	10 Nm (7.4 lbf ft)
---------------------	----	--------------------

14.1 ABS / anti-blocking system

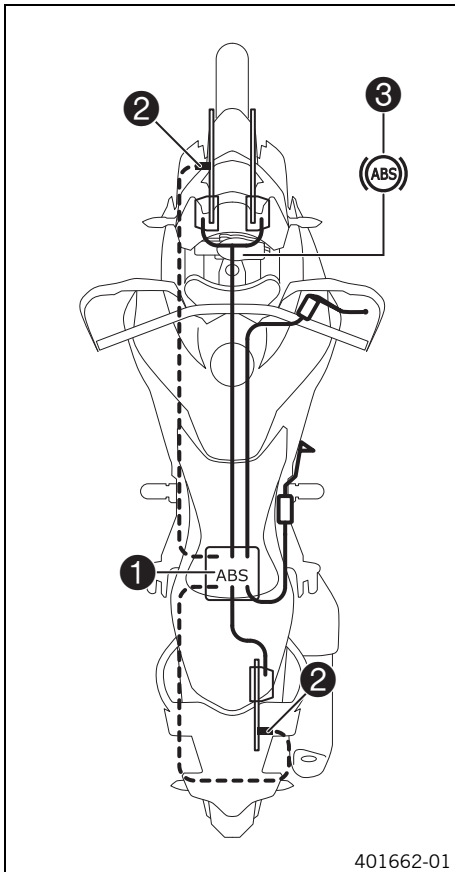

The ABS unit **1**, which consists of a hydraulic unit, brake electronics control unit, and return pump, is installed under the seat. A wheel speed sensor **2** is located at both the front and the rear wheel.



Warning

Danger of accidents Changes to the vehicle impair the function of the ABS.

- Only allow the rear wheel to spin with the front brake applied if the ABS is switched off (burn out).
- Do not make any changes to the suspension travel.
- Only use spare parts on the brake system which have been approved and recommended by KTM.
- Only use tires/wheels approved by KTM with the corresponding speed index.
- Maintain the specified tire air pressure.
- Service work and repairs must be performed professionally. (Your authorized KTM workshop will be glad to help.)

ABS is a safety system that prevents locking of the wheels when driving straight ahead without the influence of lateral forces.



Warning

Danger of accidents Vehicle rollover

- It is not always possible to prevent vehicle rollover in extreme riding situations (e. g. luggage loaded with a high center of gravity, varying road surfaces, steep descents, full braking without disengaging the gear). Adapt your riding style to the road conditions and your driving ability.

The ABS operates with two independent brake circuits (front and rear brakes). When the brake electronics control unit detects a locking tendency in a wheel, ABS begins regulat-

ing the brake pressure. The regulating process causes a slight pulsing of the hand and foot brake levers.

The ABS lamp **3** must light up after the ignition is switched on and go out after starting off. If it does not go out after starting off or if it is lit while riding, this indicates a fault in the ABS system. In this case, the ABS is no longer enabled and the wheels may lock during braking. The brake system itself stays functional; only ABS control is not available.

The ABS lamp may also light up if the rotating speeds of the front and rear wheels differ greatly under extreme riding conditions, for example when making "wheelies" or if the rear wheel spins. This causes the ABS to switch off.

To reactivate the ABS, the vehicle must be stopped and the ignition switched off. The ABS is reactivated when the vehicle is switched on again. The ABS lamp goes out when you start off.

In the "**MTC/ABS**" menu, ABS can be switched off manually.



Info

After the ignition is switched back on, ABS is reactivated.

14.2 Checking the brake discs



Warning

Danger of accidents Reduced braking efficiency due to worn brake disc(s).

- Change the worn brake disc(s) without delay. (Your authorized KTM workshop will be glad to help.)
-

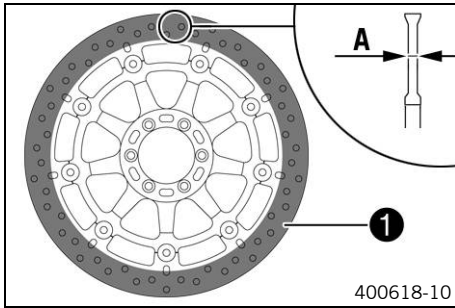

- Check the thickness of the front and rear brake discs at multiple points on each brake disc to ensure it is at least thickness **A**.

i **Info**

Wear will reduce the thickness of the brake disc at the contact surface **1** of the brake linings.

Brake discs - wear limit	
Front	4 mm (0.16 in)
Rear	4.5 mm (0.177 in)

- » If the brake disc thickness is less than the specified value.
 - Change the front brake discs. 🛠️
 - Change the rear brake discs. 🛠️
- Check the front and rear brake discs for damage, cracking, and deformation.
 - » If the brake disc exhibits damage, cracking, or deformation:
 - Change the front brake discs. 🛠️
 - Change the rear brake discs. 🛠️

14.3 Checking the brake fluid level of the front brake



Warning

Danger of accidents Failure of the brake system.

- If the brake fluid level falls below the **MIN** mark, this indicates a leakage in the brake system or worn-out brake linings. Check the brake system and do not continue riding. (Your authorized KTM workshop will be glad to help.)



Warning

Danger of accidents Reduced braking efficiency due to old brake fluid.

- Change the brake fluid of the front and rear brake according to the service schedule. (Your authorized KTM workshop will be glad to help.)

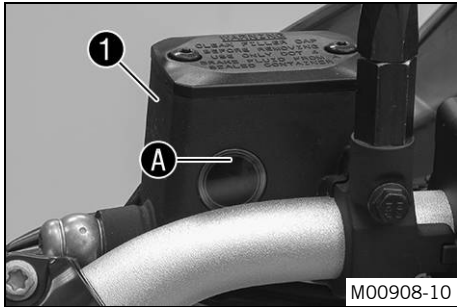

- Move the brake fluid reservoir mounted on the handlebar to a horizontal position.
- Check the brake fluid level in the brake fluid reservoir ①.
 - » If the brake fluid has dropped below marking **MIN** A:
 - Add front brake fluid. 🛠️ (📖 p. 128)

14.4 Adding front brake fluid 🛠️



Warning

Danger of accidents Failure of the brake system.

- If the brake fluid level falls below the **MIN** mark, this indicates a leakage in the brake system or worn-out brake linings. Check the brake system and do not continue riding. (Your authorized KTM workshop will be glad to help.)



Warning

Skin irritation Brake fluid can cause skin irritation on contact.

- Avoid contact with skin and eyes, and keep out of the reach of children.
- Wear suitable protective clothing and goggles.
- If brake fluid comes into contact with the eyes, flush the eyes thoroughly with water and consult a physician immediately.



Warning

Danger of accidents Reduced braking efficiency due to old brake fluid.

- Change the brake fluid of the front and rear brake according to the service schedule. (Your authorized KTM workshop will be glad to help.)



Warning

Environmental hazard Hazardous substances cause environmental damage.

- Oil, grease, filters, fuel, cleaners, brake fluid, etc., should be disposed of as stipulated in applicable regulations.



Info

Never use DOT 5 brake fluid! It is silicone-based and purple in color. Oil seals and brake lines are not designed for DOT 5 brake fluid.

Avoid contact between brake fluid and painted parts. Brake fluid attacks paint!

Use only clean brake fluid from a sealed container.

Preparatory work

- Check the front brake linings. (👉 p. 130)

Main work

- Move the brake fluid reservoir mounted on the handlebar to a horizontal position.
- Remove screws **1**.
- Remove cover **2** with membrane **3**.
- Add brake fluid to the **MAX** mark **A**.

Brake fluid DOT 4 / DOT 5.1 (👉 p. 208)

- Position cover **2** with membrane **3**.
- Mount and tighten screws **1**.

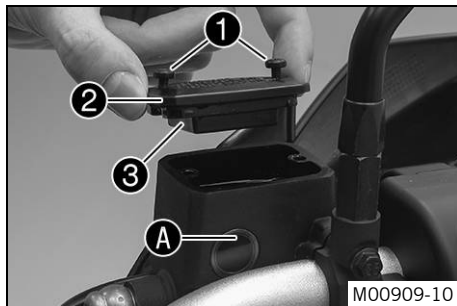



Info

Clean up overflowed or spilt brake fluid immediately with water.

14.5 Checking the front brake linings



Warning

Danger of accidents Reduced braking efficiency caused by worn brake linings.

- Change worn brake linings immediately. (Your authorized KTM workshop will be glad to help.)

Note

Danger of accidents Reduced braking efficiency caused by damaged brake discs.

- If the brake linings are not changed in time, the steel brake lining carriers grind on the brake disc. The braking effect is greatly reduced and the brake discs are destroyed. Check the brake linings regularly.

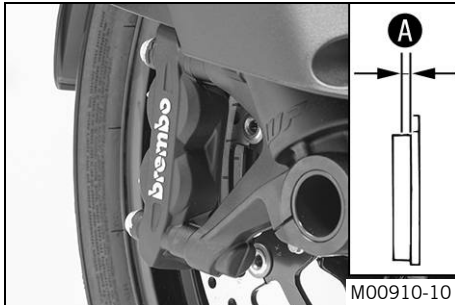

- Check all brake linings on both brake calipers to ensure they have minimum thickness **A**.

Minimum thickness	$\geq 1 \text{ mm } (\geq 0.04 \text{ in})$
-------------------	---

- » If the minimum thickness is less than specified:
 - Change the front brake linings. 🛠️
- Check all brake linings on both brake calipers for damage and cracking.
 - » If there is damage or cracking:
 - Change the front brake linings. 🛠️

14.6 Checking the rear brake fluid level



Warning

Danger of accidents Failure of the brake system.

- If the brake fluid level falls below the **MIN** mark, this indicates a leakage in the brake system or worn-out brake linings. Check the brake system and do not continue riding. (Your authorized KTM workshop will be glad to help.)



Warning

Danger of accidents Reduced braking efficiency due to old brake fluid.

- Change the brake fluid of the front and rear brake according to the service schedule. (Your authorized KTM workshop will be glad to help.)

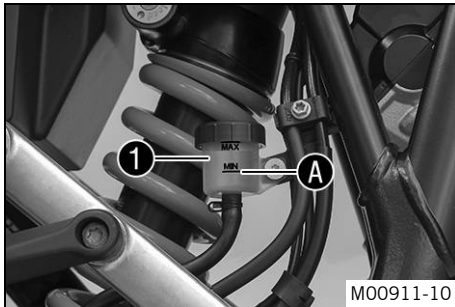

- Check the brake fluid level in the brake fluid reservoir **1**.
 - » If the fluid level reaches the **MIN** marking **A**:
 - Add rear brake fluid. 🛠️ (👉 p. 132)

14.7 Adding rear brake fluid



Warning

Danger of accidents Failure of the brake system.

- If the brake fluid level falls below the **MIN** mark, this indicates a leakage in the brake system or worn-out brake linings. Check the brake system and do not continue riding. (Your authorized KTM workshop will be glad to help.)



Warning

Skin irritation Brake fluid can cause skin irritation on contact.

- Avoid contact with skin and eyes, and keep out of the reach of children.
- Wear suitable protective clothing and goggles.
- If brake fluid comes into contact with the eyes, flush the eyes thoroughly with water and consult a physician immediately.



Warning

Danger of accidents Reduced braking efficiency due to old brake fluid.

- Change the brake fluid of the front and rear brake according to the service schedule. (Your authorized KTM workshop will be glad to help.)



Warning

Environmental hazard Hazardous substances cause environmental damage.

- Oil, grease, filters, fuel, cleaners, brake fluid, etc., should be disposed of as stipulated in applicable regulations.



Info

Never use DOT 5 brake fluid! It is silicone-based and purple in color. Oil seals and brake lines are not designed for DOT 5 brake fluid.

Avoid contact between brake fluid and painted parts. Brake fluid attacks paint!

Use only clean brake fluid from a sealed container.

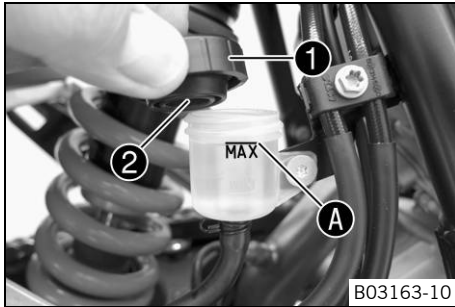

Preparatory work

- Check the rear brake linings. (☞ p. 133)

Main work

- Remove screw cap ① with membrane ②.
- Add brake fluid to the **MAX** mark **A**.

Brake fluid DOT 4 / DOT 5.1 (☞ p. 208)

- Mount and tighten screw cap ① with membrane ②.

Info

Clean up overflowed or spilt brake fluid immediately with water.

14.8 Checking the rear brake linings



Warning

Danger of accidents Reduced braking efficiency caused by worn brake linings.

- Change worn brake linings immediately. (Your authorized KTM workshop will be glad to help.)

Note

Danger of accidents Reduced braking efficiency caused by damaged brake discs.

- If the brake linings are not changed in time, the steel brake lining carriers grind on the brake disc. The braking effect is greatly reduced and the brake discs are destroyed. Check the brake linings regularly.

14 BRAKE SYSTEM

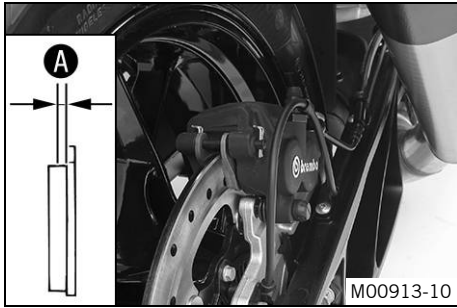

- Check the brake linings for minimum thickness **A**.

Minimum thickness A	$\geq 1 \text{ mm } (\geq 0.04 \text{ in})$
----------------------------	---

- » If the minimum thickness is less than specified:
 - Change the rear brake linings. 🛠️
- Check the brake linings for damage and cracking.
 - » If there is wear or tearing:
 - Change the rear brake linings. 🛠️

15.1 Removing the front wheel ↩

Preparatory work

- Lift the motorcycle with the rear lifting gear. (☛ p. 92)
- Remove the bottom triple clamp cover. (☛ p. 107)
- Lift the motorcycle with the front lifting gear. (☛ p. 93)

Main work

- Remove screw ❶ and pull wheel speed sensor ❷ out of the hole.

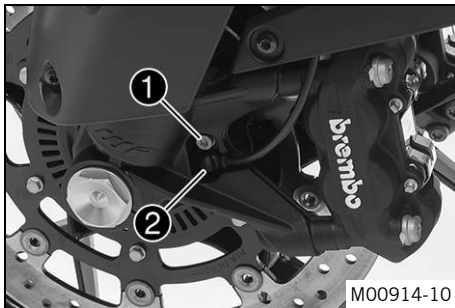

- Remove screws ❸ from both brake calipers.
- Press back the brake linings with a slight lateral tilting of the brake calipers on the brake disc.
- Pull the brake calipers carefully back from the brake discs and hang them to one side loosely.



Info

Do not pull the hand brake lever when the brake caliper has been removed.

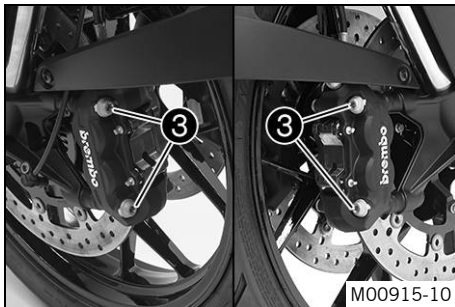

15 WHEELS, TIRES

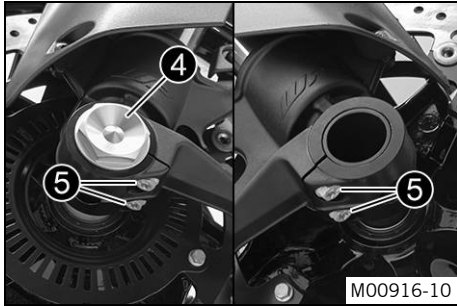

- Loosen screw ④ by several rotations.
- Release screws ⑤.
- Press on screw ④ to push the wheel spindle out the axle clamp.
- Remove screw ④.



Warning

Danger of accidents Reduced braking efficiency due to damaged brake discs.

- Always lay down the wheel in such a way that the brake discs are not damaged.

- Hold the front wheel and remove the wheel spindle. Take the front wheel out of the fork.



Info

Do not pull the hand brake lever when the front wheel is removed.

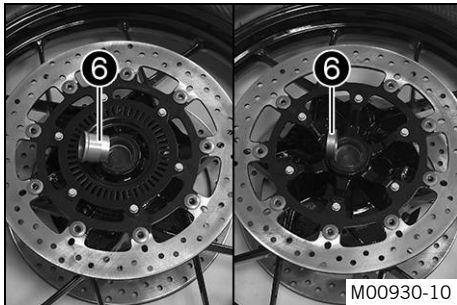

- Remove spacers ⑥.

15.2 Installing the front wheel ↩



Warning

Danger of accidents Reduced braking efficiency due to oil or grease on the brake discs.

- Always keep the brake discs free of oil and grease, and clean them with brake cleaner when necessary.

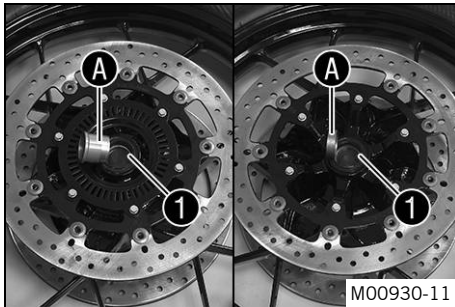

- Check the wheel bearing for damage and wear.
 - » If the wheel bearing is damaged or worn:
 - Change the front wheel bearing. ↩
- Clean and grease the shaft seal rings **1** and mating surfaces **A** of the spacers.

Long-life grease (↩ p. 211)

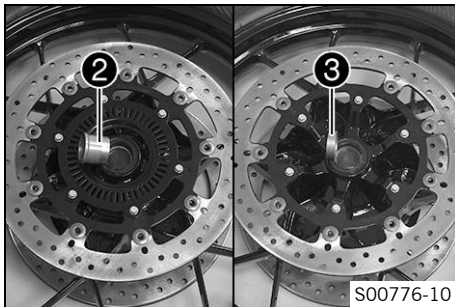

- Insert the wide spacer **2** on the left in the direction of travel.

i Info

The ABS sensor wheel is on the left viewed in the direction of travel.

- Insert the narrow spacer **3** on the right in the direction of travel.

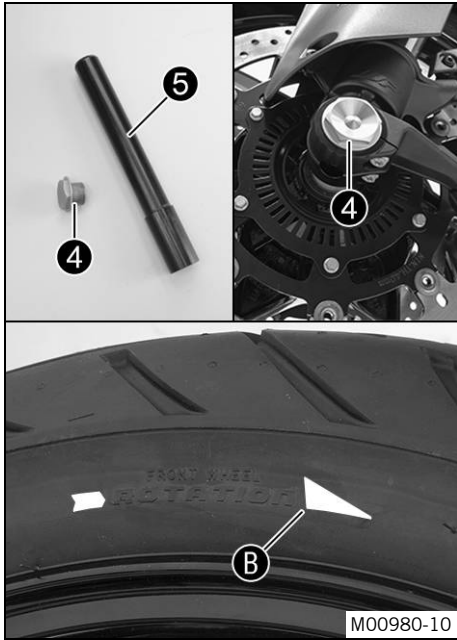

Warning

Danger of accidents Reduced braking efficiency due to oil or grease on the brake discs.

- Always keep the brake discs free of oil and grease, and clean them with brake cleaner when necessary.

- Clean and grease the screw ④ and wheel spindle ⑤.

Long-life grease (☛ p. 211)

- Lift the front wheel into the fork, position it, and insert the wheel spindle.



Info

The ABS sensor wheel is located on the left in the direction of travel. The arrow ① must point in the direction of travel. The position of the direction of travel specification on the tires can vary.

- Mount and tighten screw ④.

Guideline

Screw, front wheel spindle	M25x1.5	45 Nm (33.2 lbf ft)	Thread greased
----------------------------	---------	------------------------	----------------

15 WHEELS, TIRES

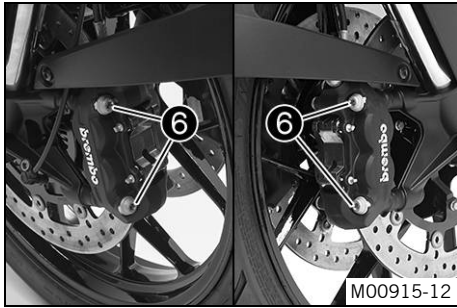

- Position the brake calipers.
 - ✓ The brake linings are correctly positioned.
- Mount screws **6** on both brake calipers but do not tighten yet.
- Operate the hand brake lever repeatedly until the brake linings are in contact with the brake disk and there is a pressure point. Fix the hand brake lever in the activated position.
 - ✓ The brake calipers straighten.
- Tighten screws **6** on both brake calipers.

Guideline

Screw, front brake caliper	M10	45 Nm (33.2 lbf ft)	Loctite® 243™
----------------------------	-----	------------------------	---------------

- Remove the fixation of the hand brake lever.
- Position the wheel speed sensor **7** in the drill hole.
- Mount and tighten screw **8**.

Guideline

Remaining chassis screws	M6	10 Nm (7.4 lbf ft)
--------------------------	----	--------------------

- Take the motorcycle from the front lifting gear. (☛ p. 94)
- Remove the rear of the motorcycle from the lifting gear. (☛ p. 92)

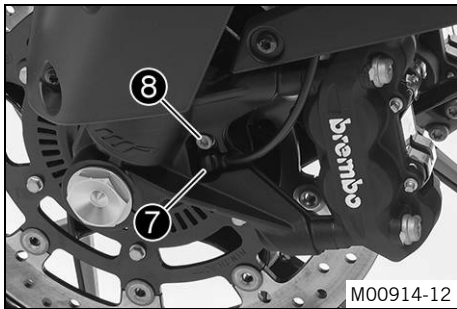

15 WHEELS, TIRES

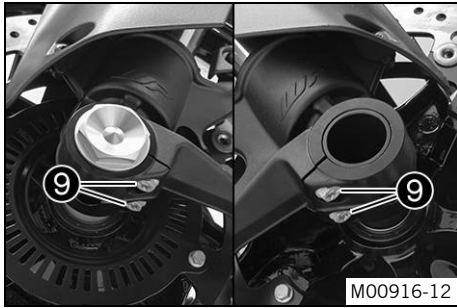

- Operate the front brake and compress the fork a few times firmly.
 - ✓ The fork legs straighten.
- Tighten screws 9.

Guideline

Screw, fork stub	M8	15 Nm (11.1 lbf ft)
------------------	----	------------------------

15.3 Removing the rear wheel ↩

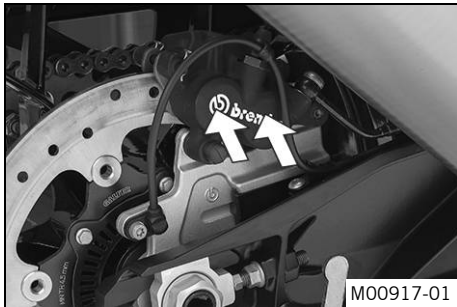

Preparatory work

- Lift the motorcycle with the rear lifting gear. (↩ p. 92)

Main work

- Press the brake caliper by hand on to the brake disc in order to press back the brake pistons.

15 WHEELS, TIRES

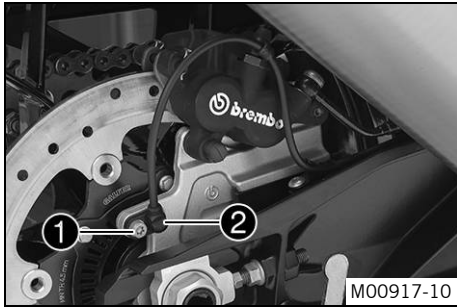

- Remove screw 1 and pull wheel speed sensor 2 out of the hole.

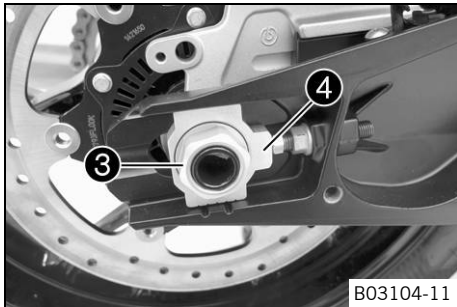

- Remove nut 3. Remove chain adjuster 4.

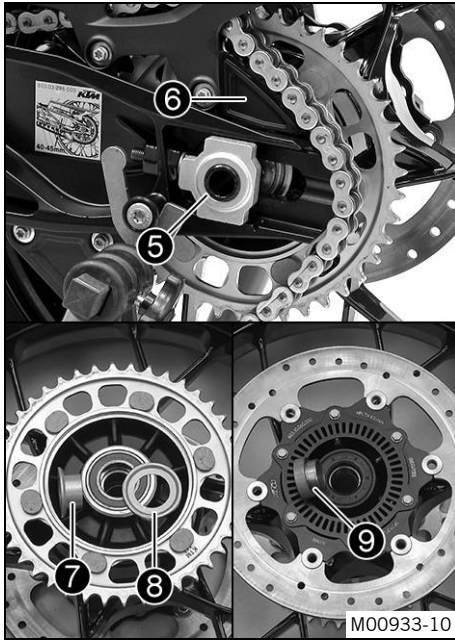

- Pull out wheel spindle **5** only far enough to allow the rear wheel to be pushed forward.
- Push the rear wheel forward as far as possible. Take the chain off of the rear sprocket and place it on chain sprocket guard **6**.



Warning

Danger of accidents Reduced braking effect caused by damaged brake discs.

- Always lay the wheel down in such a way that the brake discs are not damaged.
-
- Holding the rear wheel, withdraw the wheel spindle. Take the rear wheel out of the swing arm.



Info

Do not operate the foot brake when the rear wheel is removed.

-
- Remove spacer **7** and seal ring **8**.
 - Remove spacer **9**.

15.4 Installing the rear wheel



Warning

Danger of accidents Reduced braking efficiency due to oil or grease on the brake discs.

- Always keep the brake discs free of oil and grease, and clean them with brake cleaner when necessary.



Warning

Danger of accidents No braking effect when operating the rear brake.

- After installing the rear wheel, always operate the foot brake until the pressure point is reached.

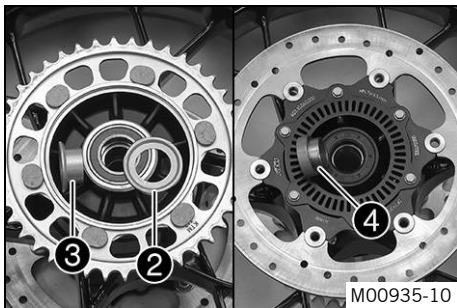
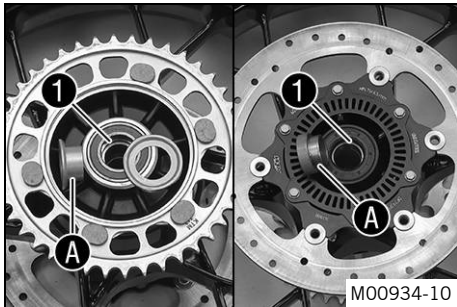

Main work

- Check the rear hub rubber dampers. ↘ (☞ p. 145)
- Check the wheel bearing for damage and wear.
 - » If the wheel bearing is damaged or worn:
 - Change the rear wheel bearing. ↘
- Clean and grease the shaft seal rings ① and mating surfaces A of the spacers.

Long-life grease (☞ p. 211)

- Clean and grease the wheel spindle as well as its thread and nut.

Long-life grease (☞ p. 211)

- Make sure that the rubber dampers and the rear sprocket carrier are correctly positioned.
- Position the seal ring ② and insert the spacer ③ on the left in the direction of travel.
- Insert the spacer ④ on the right in the direction of travel.
- Place the rear wheel in the swingarm and bring the brake disc into contact with the brake caliper.

15 WHEELS, TIRES



- Mount wheel spindle **5** but do not push it in all the way.
- Push the rear wheel as far forward as possible and place the chain on the rear sprocket.

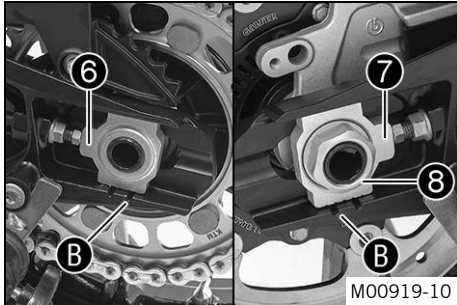

- Push the wheel spindle in all the way and mount the chain adjuster **7** and nut **8**.



Info

Mount chain adjusters **6** and **7** in the same position.

- Make sure that the chain adjusters are fitted correctly on the adjusting screws.

Guideline

In order for the rear wheel to be correctly aligned, the markings on the left and right chain adjusters must be in the same position relative to the reference marks **B**.

- Tighten nut **8**.

Guideline

Nut, rear wheel spindle	M25x1.5	90 Nm (66.4 lbf ft)	Thread greased
-------------------------	---------	------------------------	----------------

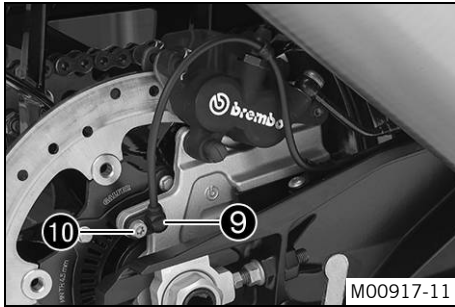

- Position the wheel speed sensor ⑨ in the drill hole.
- Mount and tighten screw ⑩.

Guideline

Remaining chassis screws	M6	10 Nm (7.4 lbf ft)
--------------------------	----	--------------------

- Operate the foot brake lever repeatedly until the brake linings are in contact with the brake disc and there is a pressure point.

Finishing work

- Remove the rear of the motorcycle from the lifting gear. (☛ p. 92)

15.5 Checking the rear hub rubber dampers ☛



Info

The engine power is transmitted from the rear sprocket to the rear wheel via 6 rubber dampers. The rubber dampers wear out during operation. If the rubber dampers are not changed in time, the rear sprocket carrier and the rear hub will be damaged.

Preparatory work

- Lift the motorcycle with the rear lifting gear. (☛ p. 92)
- Remove the rear wheel. ☛ (☛ p. 140)

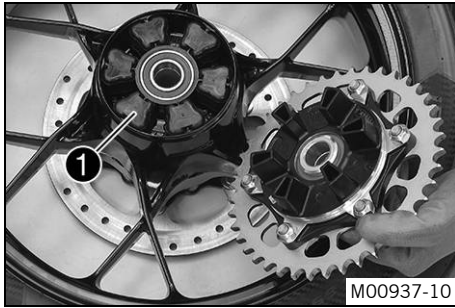

Main work

- Check the rubber dampers ① of the rear hub for damage and wear.
 - » If the rubber dampers of the rear hub are damaged or worn:
 - Change all rubber dampers in the rear hub. 🛠️

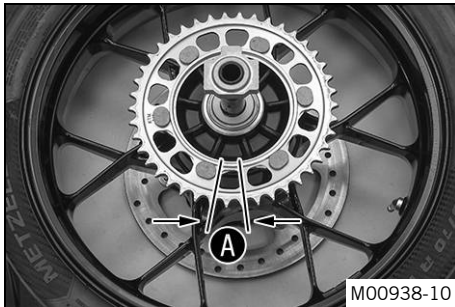

- Lay the rear wheel on a workbench with the rear sprocket facing upwards and insert the wheel spindle in the hub.
- Check the rear sprocket play ①A.



Info

Measure the play on the outside of the rear sprocket.

Play in rubber dampers, rear wheel	≤ 5 mm (≤ 0.2 in)
------------------------------------	-------------------

- » If clearance ①A larger than the specified value:
 - Change all rubber dampers in the rear hub. 🛠️

Finishing work

- Install the rear wheel. 🛠️ (📄 p. 142)
- Remove the rear of the motorcycle from the lifting gear. (📄 p. 92)

15.6 Checking the tire condition



Warning

Danger of accidents Uncontrollable vehicle handling in the event of a flat tire.

- In the interest of safety, replace damaged or worn tires immediately. (Your authorized KTM workshop will be glad to help.)



Warning

Danger of crashing Poor vehicle handling due to different tire tread patterns on front and rear wheels.

- The front and rear wheels must be fitted with tires with similar tread patterns to prevent loss of control over the vehicle.



Warning

Danger of accidents Non-approved or non-recommended tires and wheels impact the handling characteristic.

- Only use tires/wheels approved by KTM with the corresponding speed index.



Warning

Danger of accidents Reduced road grip with new tires.

- New tires have a smooth rolling surface and therefore cannot provide full road grip. The entire rolling surface must be roughened in the first 200 kilometers (124.3 miles) by moderate riding at alternating angles. The full grip levels are not achieved until the tires have been run in.
-



Info

The type, condition and air pressure of the tires all have an impact on the braking and riding response of the vehicle. Worn tires have a negative effect on vehicle handling, especially on wet surfaces.

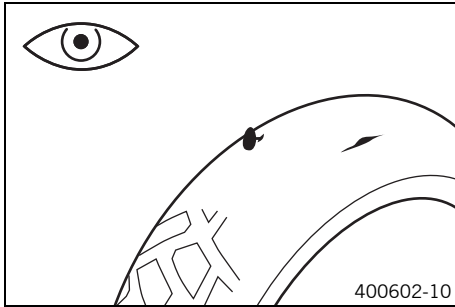

- Check the front and rear tires for cuts, run-in objects and other damage.
 - » If the tires exhibit cuts, run-in objects or other damage:
 - Change the tires.
- Check the depth of the tread.

i **Info**

Note local national regulations concerning the minimum tread depth.

Minimum tread depth	$\geq 2 \text{ mm } (\geq 0.08 \text{ in})$
---------------------	---

- » If the tread depth is less than the minimum permissible depth:
 - Change the tires.
- Check the age of the tires.

i **Info**

The tire's date of manufacture is usually part of the tire markings and is indicated by the last four digits of the **DOT** marking. The first two digits refer to the week of manufacture and last two digits refer to the year of manufacture. KTM recommends that the tires be changed after 5 years at the latest, regardless of the actual state of wear.

-
- » If a tire is more than five years old:
 - Change the tires.

15.7 Checking the tire air pressure

i **Info**

Low tire air pressure leads to abnormal wear and overheating of the tire. Correct tire air pressure ensures optimal riding comfort and maximum tire service life.

15 WHEELS, TIRES

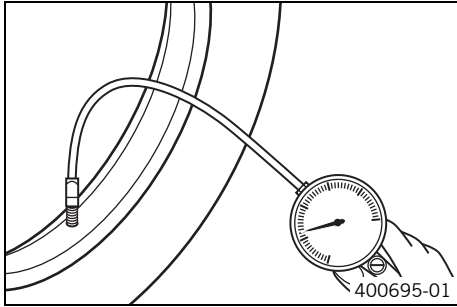

- Remove the dust cap.
- Check the tire air pressure when the tires are cold.

Tire air pressure, solo/with passenger/full payload	
Front: with cold tires	2.4 bar (35 psi)
Rear: with cold tires	2.9 bar (42 psi)

- » If the tire pressure does not meet specifications:
 - Correct the tire pressure.
- Mount the dust cap.

16.1 daytime running light



The daytime running light/parking light is integrated in the main headlight. The daytime running light (DRL) can be switched on when visibility conditions are good. Activate the daytime running light in the combination instrument. Control is provided by the brightness sensor in the combination instrument. When visibility conditions are good, the low beam is switched off and the daytime running light is switched on. It is four times brighter than the parking light. When the daytime running light is switched off, it serves as a parking light.



Info

Note the legal regulations regarding the daytime running light.

16.2 Removing the battery



Warning

Risk of injury Battery acid and battery gases cause serious chemical burns.

- Keep batteries out of the reach of children.
- Wear suitable protective clothing and goggles.
- Avoid contact with battery acid and battery gases.
- Keep sparks and open flames away from the battery. Only charge in well-ventilated rooms.
- In the event of skin contact, rinse with large amounts of water. If battery acid gets in the eyes, rinse with water for at least 15 minutes and contact a physician.



Caution

Danger of accidents If the vehicle is operated with a discharged battery or without a battery, electronic components and safety equipment may be damaged.

- Never operate the vehicle with a discharged battery or without a battery.

Preparatory work

- Switch off all power consumers and switch off the engine.
- Remove the seat. (👉 p. 97)

Main work

- Pull locking mechanism ① in the direction of the arrow.
- Fold open cover ②.

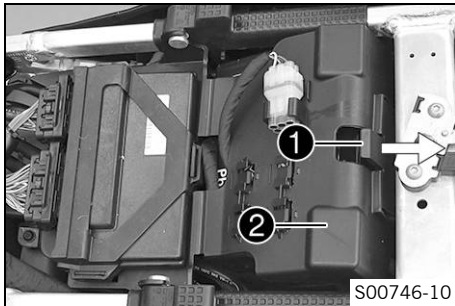

- Disconnect negative cable ③ from the battery.
- Disconnect positive cable ④ from the battery.
- Take the battery and battery case ⑤ out of the battery compartment.

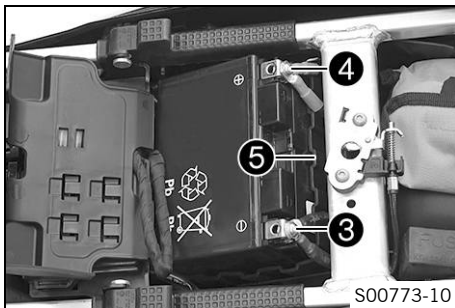

16.3 Installing the battery ↱



Warning

Risk of injury Battery acid and battery gases cause serious chemical burns.

- Keep batteries out of the reach of children.
- Wear suitable protective clothing and goggles.
- Avoid contact with battery acid and battery gases.
- Keep sparks and open flames away from the battery. Only charge in well-ventilated rooms.
- In the event of skin contact, rinse with large amounts of water. If battery acid gets in the eyes, rinse with water for at least 15 minutes and contact a physician.



Caution

Danger of accidents If the vehicle is operated with a discharged battery or without a battery, electronic components and safety equipment may be damaged.

- Never operate the vehicle with a discharged battery or without a battery.

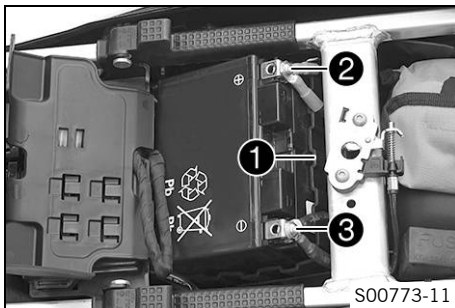

Main work

- Position the battery in battery case ❶.

Guideline

The even side of the battery case must be opposite the poles.

- Position the battery and battery case in the battery compartment.
- Position the positive cable ❷ and mount and tighten the screw.

Guideline

Screw, battery terminal	M6	4.5 Nm (3.32 lbf ft)
-------------------------	----	-------------------------

- Position the negative cable ❸ and mount and tighten the screw.

Guideline

Screw, battery terminal	M6	4.5 Nm (3.32 lbf ft)
-------------------------	----	-------------------------

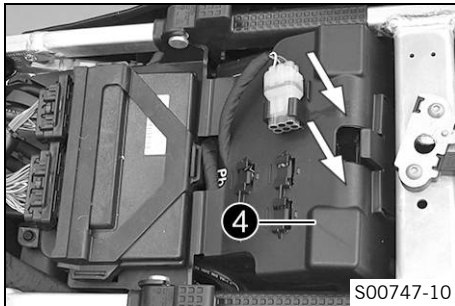

- Close the cover ④ and push down slightly.
✓ The cover engages with an audible click.

Finishing work

- Mount the seat. (👉 p. 97)
- Set the time and date.

16.4 Recharging the battery ↩



Warning

Risk of injury Battery acid and battery gases cause serious chemical burns.

- Keep batteries out of the reach of children.
- Wear suitable protective clothing and goggles.
- Avoid contact with battery acid and battery gases.
- Keep sparks and open flames away from the battery. Only charge in well-ventilated rooms.
- In the event of skin contact, rinse with large amounts of water. If battery acid gets in the eyes, rinse with water for at least 15 minutes and contact a physician.



Warning

Environmental hazard The battery contains elements that are harmful to the environment.

- Do not dispose of batteries with the household waste. Dispose of a defective battery in an environmentally friendly manner. Give the battery to your authorized KTM dealer or dispose of it at a collection point for used batteries.



Warning

Environmental hazard Hazardous substances cause environmental damage.

- Oil, grease, filters, fuel, cleaners, brake fluid, etc., should be disposed of as stipulated in applicable regulations.
-



Info

Even when there is no load on the battery, it discharges steadily.

The charge state and the type of charge are very important for the service life of the battery.

Rapid recharging with a high charging current shortens the battery's service life.

If the charging current, charging voltage, and charging time are exceeded, electrolyte escapes through the safety valves. This reduces the battery capacity.

If the battery is depleted from starting the vehicle repeatedly, the battery must be charged immediately.

If the battery is left in a discharged state for an extended period, it will become over-discharged and sulfate, destroying the battery.

The battery is maintenance-free, i.e., the acid level does not have to be checked.

If the battery is not charged using the KTM battery charger, the battery must be removed for charging. Otherwise, overvoltage may damage electronic components. Charge the battery according to the instructions on the battery housing.

Preparatory work

- Switch off all power consumers and switch off the engine.
- Remove the seat. (🔧 p. 97)

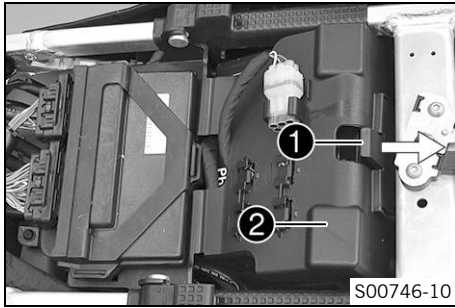

Main work

- Pull locking mechanism ① in the direction of the arrow.
- Fold open cover ②.

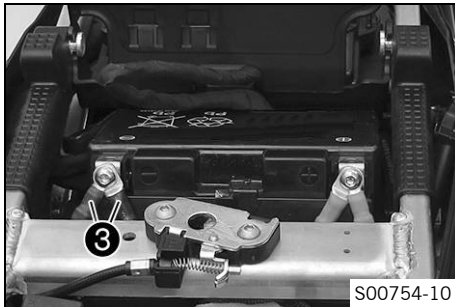

- Disconnect negative cable ③ of the battery to avoid damage to the motorcycle's electronics.



- Connect the battery charger to the battery. Switch on the battery charger.

Battery charger (58429074000)

i Info

You can also use the battery charger to test the open-circuit voltage and start potential of the battery, and to test the alternator. With this device, you cannot overcharge the battery.
Charge the battery with a maximum of 10% of the capacity specified on the battery housing.

- Switch off the battery charger after charging and disconnect from the battery.

Guideline

The charging current, charging voltage, and charging time must not be exceeded.	
Charge the battery regularly when the motorcycle is not in use	3 months

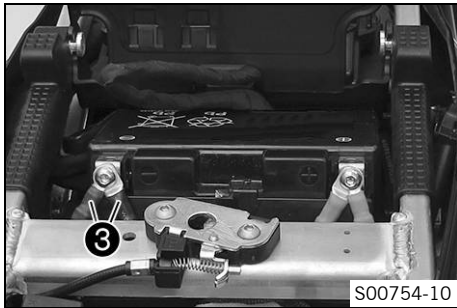

- Connect both negative cables **3** with the battery.

Guideline

Screw, battery terminal	M6	4.5 Nm (3.32 lbf ft)
-------------------------	----	-------------------------

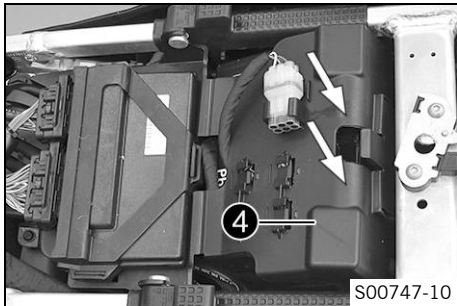

- Close cover **4** and push down slightly.
 ✓ The cover engages with an audible click.

Finishing work

- Mount the seat. (🔧 p. 97)
- Set the time and date.

16.5 Changing the main fuse



Warning

Fire hazard The electrical system can be overloaded if the wrong fuses are used.

- Use only fuses with the prescribed amperage. Never bypass or repair fuses.

Preparatory work

- Switch off all power consumers and switch off the engine.
- Remove the seat. (👉 p. 97)

Main work

- Remove screws ①.
- Raise rear fairing ② slightly.

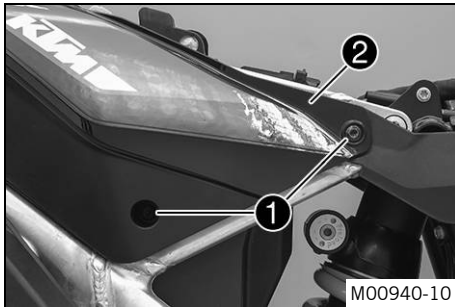

- Remove protection caps ③.

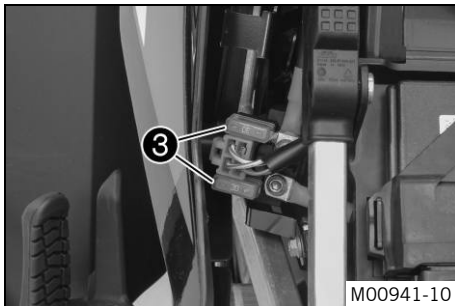

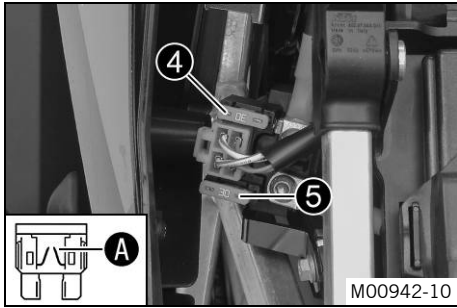

- Remove the faulty main fuse ④.



Info

A defective fuse is indicated by a burned-out fuse wire **A**.
 A reserve fuse ⑤ is located in the starter relay.
 The main fuse protects all power consumers of the vehicle.

- Install a new main fuse.

Fuse (58011109130) (☛ p. 202)

- Check that the electrical equipment is functioning properly.
- Mount protection covers.



Tip

Insert a new spare fuse into the starter relay to have it available when needed.

- Position rear fairing ②.
- Mount and tighten screws ①.

Guideline

Screw, cover part	M5	3.5 Nm (2.58 lbf ft)
-------------------	----	-------------------------

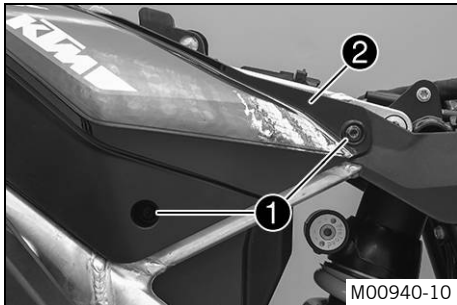

Finishing work

- Mount the seat. (☛ p. 97)
- Set the time and date.

16.6 Changing the fuses in the fuse box



Warning

Fire hazard The electrical system can be overloaded if the wrong fuses are used.

- Use only fuses with the prescribed amperage. Never bypass or repair fuses.



Info

The fuse box containing the fuses of individual power consumers is located under the seat.

Preparatory work

- Switch off all power consumers and switch off the engine.
- Remove the seat. (↖ p. 97)

Main work

- Open fuse box cover ❶.

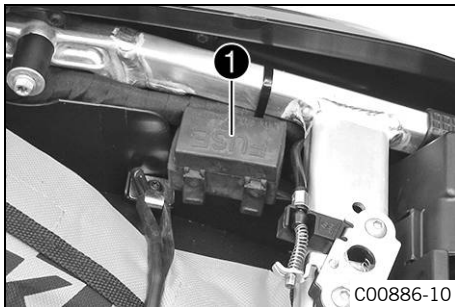

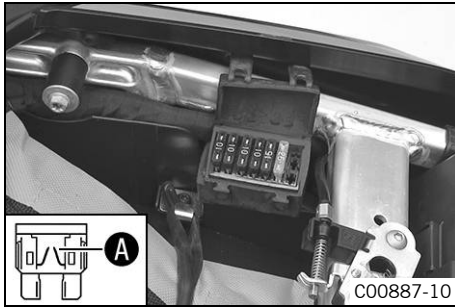

- Check the fuses.

i Info

A defective fuse is indicated by a burned-out fuse wire **A**.

- Remove the defective fuse.

Guideline

Fuses res - 10 A - spare fuses
Fuse 1 - 10 A - power supply for control units and components
Fuse 2 - 10 A - optional auxiliary equipment
Fuse 3 - 15 A - ABS hydraulic unit
Fuse 4 - 25 A - ABS return pump
Fuse 5 - not assigned

- Use spare fuses with the correct rating only.

Fuse (58011109110) (☞ p. 201)
Fuse (58011109115) (☞ p. 201)
Fuse (58011109125) (☞ p. 202)

i Tip

Insert a spare fuse so that it is available if needed.

- Check that the power consumer is functioning properly.
- Close the fuse box cover.

Finishing work

- Mount the seat. (☞ p. 97)

16.7 Removing the headlight mask with the headlight

Preparatory work

- Switch off all power consumers and switch off the engine.
- Remove the seat. (☞ p. 97)
- Remove the front side cover. (☞ p. 109)
- Remove the tank cover. (☞ p. 119)
- Remove the mask spoiler. ☞ (☞ p. 112)
- Remove the wind shield. (☞ p. 123)

Main work

- Remove screws ①.
- Remove the headlight mask forward.

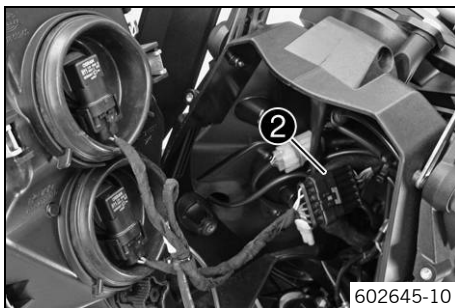
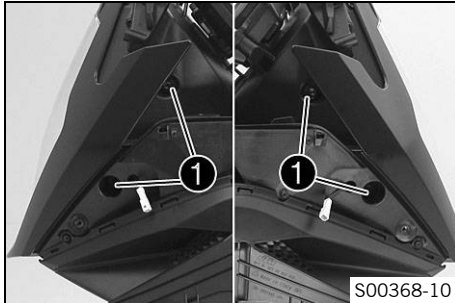

- Disconnect plug-in connector ②.
- Place the headlight mask onto a soft cloth so that the headlight is not damaged.

16.8 Refitting the headlight mask with the headlight

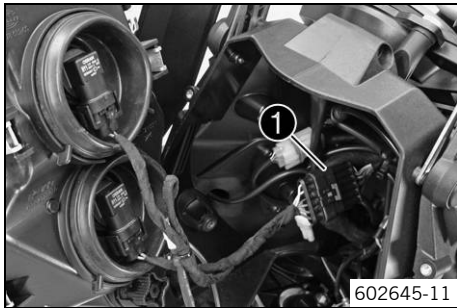

602645-11

Main work

- Connect plug-in connector ① of the headlight.
- Check that the lighting is functioning properly.
- Position the headlight mask.

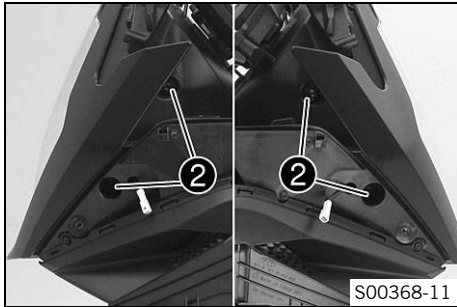

S00368-11

- Mount and tighten screws ②.

Guideline

Remaining chassis screws	M6	10 Nm (7.4 lbf ft)
--------------------------	----	--------------------

Finishing work

- Install the wind shield. (☞ p. 123)
- Install the mask spoiler. ☞ (☞ p. 114)
- Install the tank cover. (☞ p. 121)
- Install the front side cover. (☞ p. 110)
- Mount the seat. (☞ p. 97)
- Check the headlight setting. (☞ p. 167)

16.9 Changing the low beam bulb

Note

Damage to reflector Reduced brightness.

- Grease on the lamp will evaporate due to the heat and be deposited on the reflector. Clean the lamp and keep it free of grease before mounting.

Preparatory work

- Switch off all power consumers and switch off the engine.
- Remove the seat. (☞ p. 97)
- Remove the front side cover. (☞ p. 109)
- Remove the tank cover. (☞ p. 119)
- Remove the mask spoiler. ☞ (☞ p. 112)
- Remove the wind shield. (☞ p. 123)
- Remove the headlight mask with the headlight. (☞ p. 161)

Main work

- Push headlight bulb ❶ lightly into the bulb socket, turn it all the way counterclockwise, and pull it out.
- Unplug connector ❷.

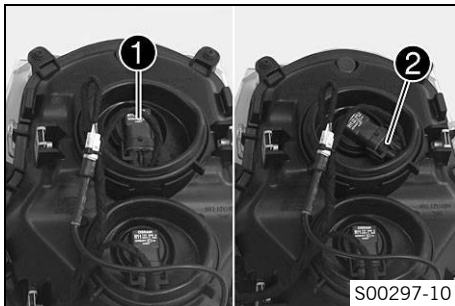

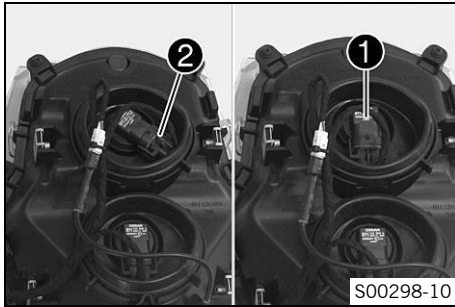

- Plug connector ② into the new headlight bulb.

Low beam (H11/socket PGJ19-2) (☛ p. 202)

- Position headlight bulb ① into the bulb socket and turn it all the way clockwise.
✓ The headlight bulb is locked into the bulb socket.

Finishing work

- Refit the headlight mask with the headlight. (☛ p. 162)
- Install the wind shield. (☛ p. 123)
- Install the mask spoiler. ☞ (☛ p. 114)
- Install the tank cover. (☛ p. 121)
- Install the front side cover. (☛ p. 110)
- Mount the seat. (☛ p. 97)
- Check the headlight setting. (☛ p. 167)

16.10 Changing the high beam bulb

Note

Damage to reflector Reduced brightness.

- Grease on the lamp will evaporate due to the heat and be deposited on the reflector. Clean the lamp and keep it free of grease before mounting.

Preparatory work

- Switch off all power consumers and switch off the engine.

- Remove the seat. (☞ p. 97)
- Remove the front side cover. (☞ p. 109)
- Remove the tank cover. (☞ p. 119)
- Remove the mask spoiler. ☞ (☞ p. 112)
- Remove the wind shield. (☞ p. 123)
- Remove the headlight mask with the headlight. (☞ p. 161)

Main work

- Push headlight bulb ① lightly into the bulb socket, turn it all the way counterclockwise, and pull it out.
- Unplug connector ②.

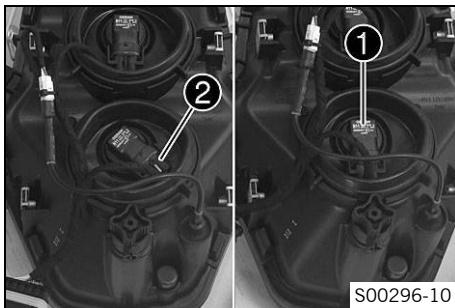
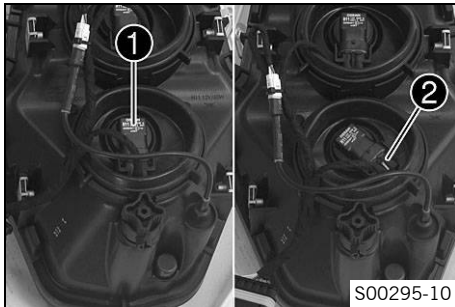

- Plug connector ② into the new headlight bulb.

High beam (H11/socket PGJ19-2) (☞ p. 202)

- Position headlight bulb ① into the bulb socket and turn it all the way clockwise.
✓ The headlight bulb is locked into the bulb socket.

Finishing work

- Refit the headlight mask with the headlight. (☞ p. 162)
- Install the wind shield. (☞ p. 123)

- Install the mask spoiler. (☞ p. 114)
- Install the tank cover. (☞ p. 121)
- Install the front side cover. (☞ p. 110)
- Mount the seat. (☞ p. 97)
- Check the headlight setting. (☞ p. 167)

16.11 Changing the turn signal bulb

Note

Damage to reflector Reduced brightness.

- Grease on the lamp will evaporate due to the heat and be deposited on the reflector. Clean the lamp and keep it free of grease before mounting.

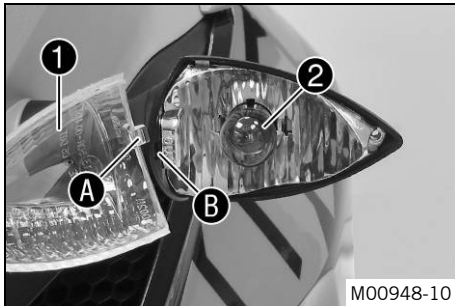

- Remove the screw on the rear of the turn signal housing.
- Carefully remove diffuser ①.
- Press bulb ② carefully into the socket, turn it counterclockwise by about 30°, and pull it out of the socket.

Info

Do not touch the reflector with your fingers, and keep it free from grease.

- Press the new bulb carefully into the socket and turn it clockwise until it stops.

Turn signal (RY10W / socket BAU15s) (☞ p. 202)

- Check the turn signal to make sure it is functioning properly.
- Position the diffuser.

i Info
Hook in projection **A** at recess **B**.

- Insert the screw and first turn it counterclockwise until it engages in the thread. Tighten the screw slightly.

16.12 Checking the headlight setting

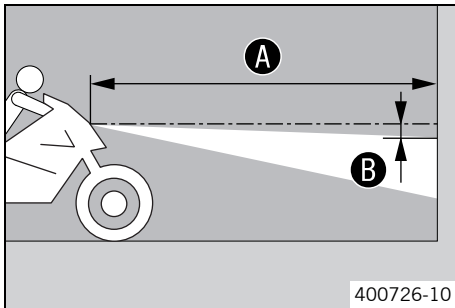

- Park the vehicle on a horizontal surface in front of a light-colored wall and make a mark at the height of the center of the low beam headlight.
- Make another mark at a distance **B** under the first mark.

Guideline

Distance B	5 cm (2 in)
-------------------	-------------

- Position the vehicle perpendicular to the wall at a distance **A** from the wall and switch on the low beam.

Guideline

Distance A	5 m (16 ft)
-------------------	-------------

- The rider, with luggage and passenger if applicable, now mounts the motorcycle.
- Check the headlight setting.

The light-dark boundary must lie exactly on the lower mark when the motorcycle is ready to operate with the rider mounted along with any luggage and a passenger if applicable.

- » If the boundary between light and dark does not meet specifications:
 - Adjust the headlight range. (☛ p. 168)

16.13 Adjusting the headlight range

Preparatory work

- Check the headlight setting. (☞ p. 167)
- Remove the bottom triple clamp cover. (☞ p. 107)

Main work

- Turn adjusting screw **1** to adjust the headlight range.

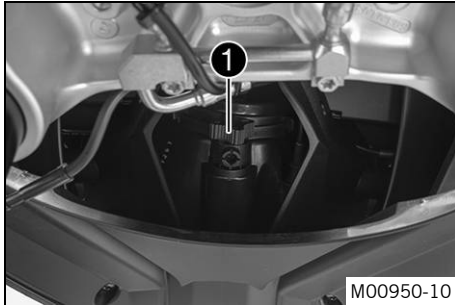

i Info

Turn clockwise to increase the headlight range; turn counterclockwise to reduce the headlight range.

If you have a payload, you may have to correct the headlight range.

- Set the headlight to marking **B**.

Guideline

The light-dark boundary must lie exactly on the lower mark **B** when the motorcycle is ready to operate with the rider mounted along with any luggage and a passenger if applicable.

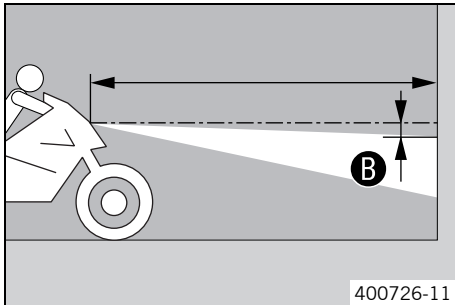

Finishing work

- Install the bottom triple clamp cover. (☞ p. 108)

16.14 Activating/deactivating the ignition key

i Info

The orange programming key must only be used for activating and deactivating!

If a black ignition key is lost or needs to be replaced, the individual black ignition keys need to be enabled or disabled using the orange programming key. This prevents the vehicle from being operated with the lost black ignition key.

You can activate or deactivate up to four black ignition keys. Only the black ignition keys programmed during an activation procedure are valid. All black ignition keys not programmed during the activation procedure are invalid, but can be reprogrammed in a further activation procedure.

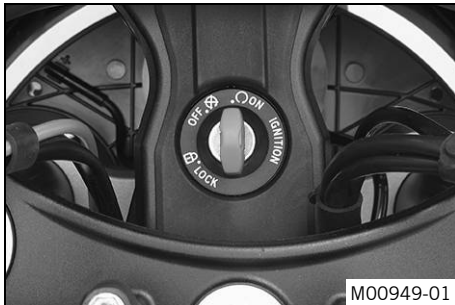
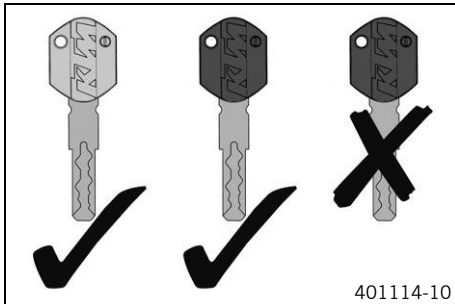

Loss of a black ignition key (additional black ignition keys are available):

The following procedure deactivates all activated black ignition keys that are not included in the procedure.

- Press the emergency OFF switch to the position **ON** ○.
- Insert the orange programming key in the ignition lock.
- Switch on the ignition by turning the orange programming key to the **ON** position ○.
 - ✓ Immobilizer indicator lamp ■ lights up.
- Switch off the ignition by turning the orange programming key to the **OFF** position ⊗.
- Pull out the orange programming key.
- Insert the black ignition key in the ignition lock.
- Switch on the ignition by turning the black ignition key to the position **ON** ○.
 - ✓ Immobilizer indicator lamp ■ lights up.

- Switch off the ignition by turning the black ignition key to the position **OFF** ☒.
- Remove the black ignition key.
- Insert the orange programming key in the ignition lock.
- Switch on the ignition by turning the orange programming key to the **ON** position ○.
- ✓ The immobilizer indicator lamp ■ flashes according to the number of functional black ignition keys including the orange programming key. In this case, it flashes twice.
- Switch off the ignition by turning the orange programming key to the **OFF** position ☒.
- Pull out the orange programming key.
- ✓ The lost black ignition key is deactivated.
- ✓ The existing black ignition key is reactivated.

Loss of all black ignition keys (no black ignition keys are available):

This procedure is important to prevent misuse of the lost black ignition key.

- Press the emergency OFF switch to the position **ON** ○.

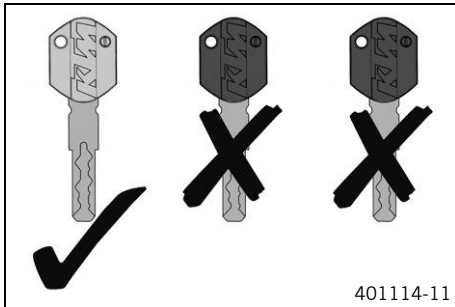

401114-11

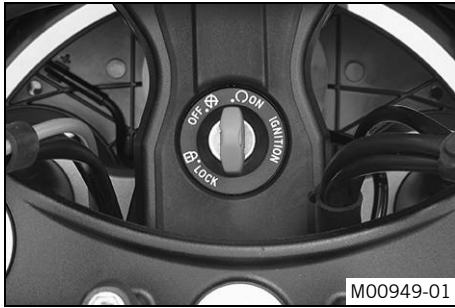

- Insert the orange programming key in the ignition lock.
- Switch on the ignition by turning the orange programming key to the **ON** position ○.
 - ✓ Immobilizer indicator lamp ■ lights up.
- Switch off the ignition by turning the orange programming key to the **OFF** position ⊗.
- Switch on the ignition by turning the orange programming key to the **ON** position ○.
 - ✓ The immobilizer indicator lamp ■ flashes according to the number of functional black ignition keys including the orange programming key. In this case, it flashes once since all black ignition keys are deactivated.
- Switch off the ignition by turning the orange programming key to the **OFF** position ⊗.
- Pull out the orange programming key.
 - ✓ All black ignition keys are deactivated.
- Order a new black ignition key according to the key number on the **KEYCODECARD** and activate it.

To activate up to three black ignition keys:

- Press the emergency OFF switch to the position **ON** ○.
- Insert the orange programming key in the ignition lock.
- Switch on the ignition by turning the orange programming key to the **ON** position ○.
 - ✓ Immobilizer indicator lamp ■ lights up.
- Switch off the ignition by turning the orange programming key to the **OFF** position ⊗.
- Pull out the orange programming key.
- Insert the black ignition key in the ignition lock.
- Switch on the ignition by turning the black ignition key to the position **ON** ○.
 - ✓ Immobilizer indicator lamp ■ lights up.
- Switch off the ignition by turning the black ignition key to the position **OFF** ⊗.
- Remove the black ignition key.
- If two other black ignition keys are to be activated, repeat the last steps with the respective ignition key.

- If the last black ignition key was activated, insert the orange programming key into the ignition lock.
- Switch on the ignition by turning the orange programming key to the **ON** position ○.
- ✓ The immobilizer indicator lamp ■ flashes according to the number of functional black ignition keys including the orange programming key.
- Switch off the ignition by turning the orange programming key to the **OFF** position ⊗.
- Pull out the orange programming key.



Info

Activation of the ignition key is finished.

To activate four black ignition keys:

- Press the emergency OFF switch to the position **ON** ○.
- Insert the orange programming key in the ignition lock.
- Switch on the ignition by turning the orange programming key to the **ON** position ○.
- ✓ Immobilizer indicator lamp ■ lights up.
- Switch off the ignition by turning the orange programming key to the **OFF** position ⊗.
- Pull out the orange programming key.
- Insert the black ignition key in the ignition lock.
- Switch on the ignition by turning the black ignition key to the position **ON** ○.
- ✓ Immobilizer indicator lamp ■ lights up.
- Switch off the ignition by turning the black ignition key to the position **OFF** ⊗.
- Remove the black ignition key.
- If three other black ignition keys are to be activated, repeat the last steps with the respective ignition key.



Info

After the fourth black ignition key has been activated, programming is finished.

17.1 Checking the coolant level in the compensating tank



Warning

Danger of scalding During motorcycle operation, the coolant gets very hot and is under pressure.

- Do not remove the radiator cap, radiator hoses or other cooling system components when the engine is hot. Allow the engine and cooling system to cool down. In case of scalding, rinse immediately with lukewarm water.



Warning

Danger of poisoning Coolant is poisonous and a health hazard.

- Coolant must not come into contact with the skin, eyes, or clothing. If contact occurs with the eyes, rinse with water immediately and contact a physician. Immediately clean contaminated areas on the skin with soap and water. If fuel is swallowed, contact a physician immediately. Change clothing that is contaminated with coolant. Keep coolant out of reach of children.

Condition

The engine is cold.

The radiator is completely full.

- Park the motorcycle on a horizontal surface.
- Check the coolant level in the compensating tank ①.

The coolant level must be between **MIN** and **MAX**.

- » If there is no coolant in the compensating tank:
 - Check the cooling system for leaks. 🛠️



Info

Do not start up the motorcycle!

- Add coolant/bleed the cooling system. 🛠️
- » If the coolant in the compensating tank is not at the required level, but the tank is not empty:

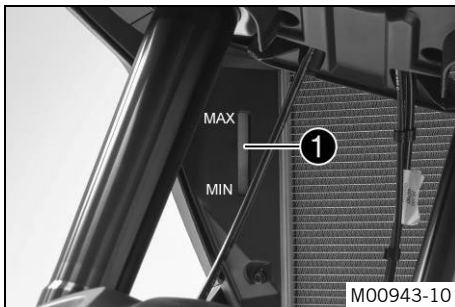

- Correct the coolant level in the compensating tank. (🔧 p. 175)

17.2 Correcting the coolant level in the compensating tank



Warning

Danger of scalding During motorcycle operation, the coolant gets very hot and is under pressure.

- Do not remove the radiator cap, radiator hoses or other cooling system components when the engine is hot. Allow the engine and cooling system to cool down. In case of scalding, rinse immediately with lukewarm water.



Warning

Danger of poisoning Coolant is poisonous and a health hazard.

- Coolant must not come into contact with the skin, eyes, or clothing. If contact occurs with the eyes, rinse with water immediately and contact a physician. Immediately clean contaminated areas on the skin with soap and water. If fuel is swallowed, contact a physician immediately. Change clothing that is contaminated with coolant. Keep coolant out of reach of children.

Condition

The engine is cold.

The radiator is completely full.

Preparatory work

- Check the coolant level in the compensating tank. (🔧 p. 174)
- Remove the front side cover. (🔧 p. 109)



Info

Only disassemble the right-hand side.



Main work

- Remove the cover ❶ of the compensating tank.

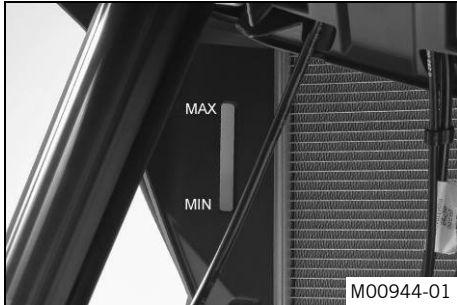

- Add coolant until the coolant reaches the specified level.

Guideline

The coolant level must be between **MIN** and **MAX**.

Coolant (☛ p. 208)

- Mount the cover of the compensating tank.

Finishing work

- Install the front side cover. (☛ p. 110)

18.1 "Drive Mod"

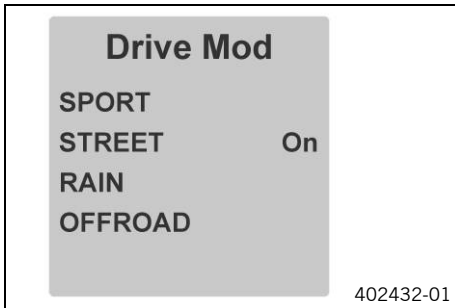

Possible states

- SPORT – Homologated performance with very direct response; the traction control allows greater slip on the rear wheel
- STREET – Homologated performance with balanced response; the traction control allows normal slip on the rear wheel
- RAIN – Reduced homologated performance for better ridability; the traction control allows normal slip on the rear wheel
- OFFROAD (optional) – Reduced homologated performance for better ridability; the traction control allows high slip on the rear wheel

Various vehicle tunings can be selected in the "**Drive Mod**" menu. You can choose from "**SPORT**", "**STREET**", "**RAIN**" and "**OFFROAD**" (optional).

The drive mode selected last is displayed on the right in the segment display.



Info

The drive mode selection has no influence on the ABS.

18.2 Traction control (TC)

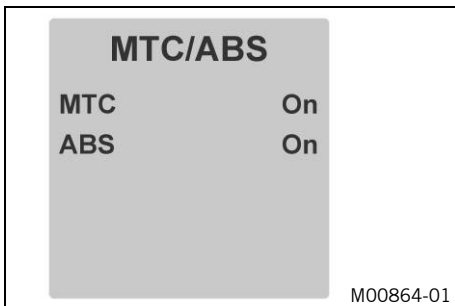

The traction control (TC) lowers the engine torque in case of loss of traction in the rear wheel. Depending on the traction control setting, a slight slip on the rear wheel may be desirable. Example: offroad (optional).





Info

When traction control is switched off, the rear wheel may spin during high acceleration and on surfaces with low grip.
After the ignition is switched back on, traction control is enabled again.

Traction control is controlled via the "**Drive Mod**" (☛ p. 177) menu on the combination instrument. Traction control can be switched off in the "**MTC/ABS**" menu.

**Info**

When traction control is active, the TC lamp  flashes.
When traction control is switched off, the TC lamp  is lit.

19.1 Checking the engine oil level



Info

Oil consumption depends on the riding style and the operating conditions.

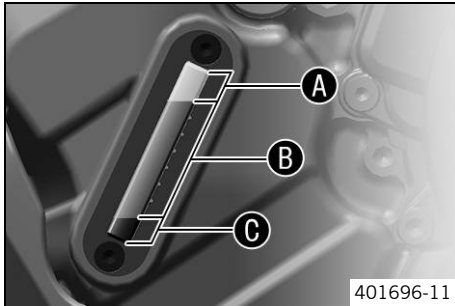

Condition

The engine is at operating temperature.

Preparatory work

- Stand the motorcycle upright on a horizontal surface.

Main work

- Check the engine oil level in the engine oil level viewer.



Info

After switching off the engine, wait one minute before checking the level.

The engine oil level should be in the upper part of the range **B** of the engine oil level viewer.

- » When the engine oil level is in area **A** of the engine oil level viewer:
 - Do not add engine oil.
- » When the engine oil level is in area **B** of the engine oil level viewer:
 - Engine oil can be added.
- » When the engine oil level is in area **C** of the engine oil level viewer:
 - Add engine oil. (🔧 p. 184)

19.2 Changing the engine oil and oil filter, cleaning the oil screens 🛠️



Warning

Danger of scalding Engine oil and gear oil get very hot when the motorcycle is ridden.

- Wear appropriate protective clothing and safety gloves. In case of burns, rinse immediately with lukewarm water.



Warning

Environmental hazard Hazardous substances cause environmental damage.

- Oil, grease, filters, fuel, cleaners, brake fluid, etc., should be disposed of as stipulated in applicable regulations.

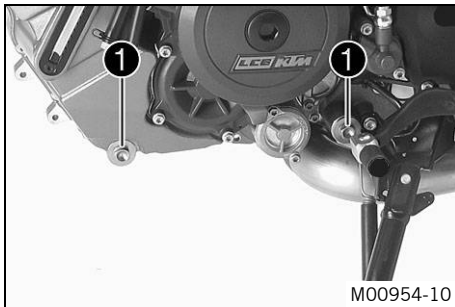

Preparatory work

- Remove the engine guard. (🔧 p. 124)

Main work

- Stand the motorcycle on its side stand on a horizontal surface.
- Place a suitable container under the engine.
- Remove oil drain plugs ① with the magnets, O-rings, and oil screens.

19 SERVICE WORK ON THE ENGINE

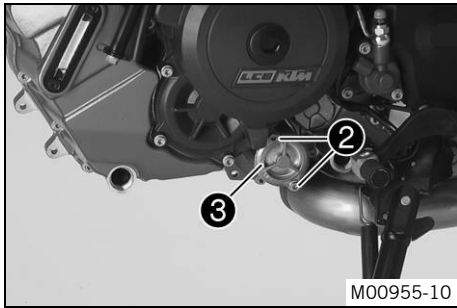

- Remove screws ②. Remove oil filter cover ③ with the O-ring.

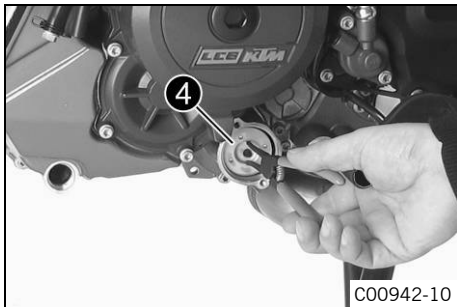

- Pull oil filter ④ out of the oil filter housing.

Circlip pliers reverse (51012011000)

- Completely drain the engine oil.
- Thoroughly clean the parts and sealing surface.

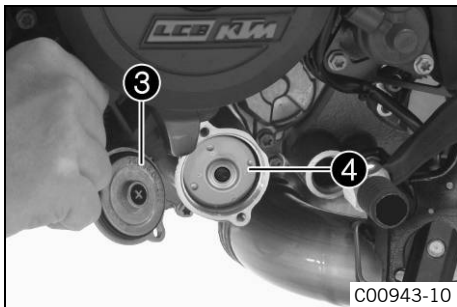

- Insert oil filter ④.



Info

Only insert the oil filter by hand.

- Lubricate the O-ring of the oil filter cover. Mount oil filter cover ③.

19 SERVICE WORK ON THE ENGINE

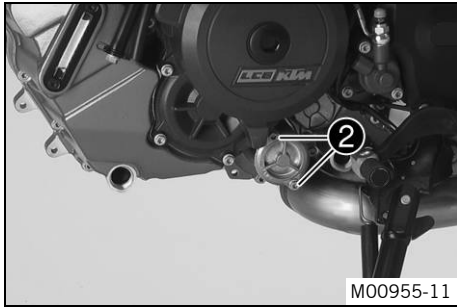

- Mount and tighten screws ②.

Guideline

Remaining engine screws	M5	6 Nm (4.4 lbf ft)
-------------------------	----	-------------------

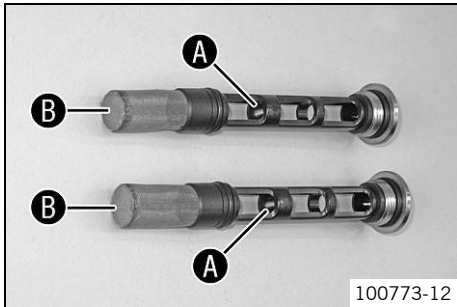

- Thoroughly clean magnets ① and oil screens ② of the oil drain plugs.

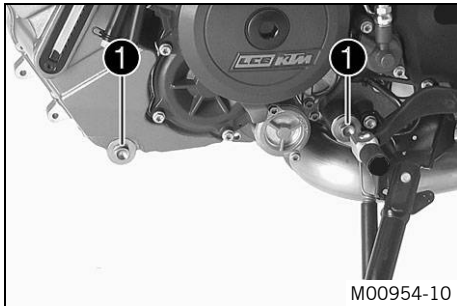

- Mount and tighten oil drain plugs ① with the magnets, O-rings, and oil screens.

Guideline

Oil drain plug	M20x1.5	20 Nm (14.8 lbf ft)
----------------	---------	------------------------

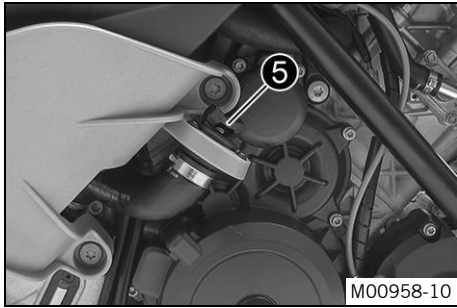

- Add the oil quantity in two separate operations.

Engine oil	3.60 l (3.8 qt.)	Outside temperature: ≥ 0 °C (≥ 32 °F)	Engine oil (SAE 10W/50) (☛ p. 208)
		Outside temperature: < 0 °C (< 32 °F)	Engine oil (SAE 5W/40) (☛ p. 209)

- Remove screw plug **5** and fill in engine oil.

Engine oil (1st quantity) approx.	3.0 l (3.2 qt.)	Outside temperature: ≥ 0 °C (≥ 32 °F)	Engine oil (SAE 10W/50) (☛ p. 208)
		Outside temperature: < 0 °C (< 32 °F)	Engine oil (SAE 5W/40) (☛ p. 209)

- Mount screw plug **5**.



Danger

Danger of poisoning Exhaust gases are toxic and inhaling them may result in unconsciousness and/or death.

- When running the engine, always make sure there is sufficient ventilation, and do not start or run the engine in an enclosed space without an effective exhaust extraction system.

- Start the engine and check that it is oil-tight.

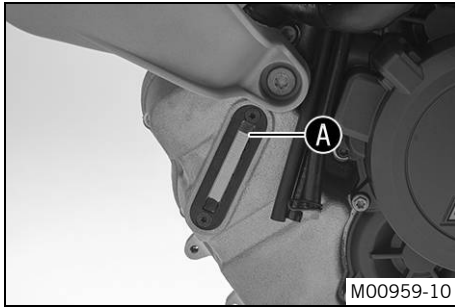

- Remove the screw plug and add the remaining engine oil to the upper marking **A** on the engine oil level viewer.
- Mount the screw plug.



Danger

Danger of poisoning Exhaust gases are toxic and inhaling them may result in unconsciousness and/or death.

- When running the engine, always make sure there is sufficient ventilation, and do not start or run the engine in an enclosed space without an effective exhaust extraction system.
-
- Start the engine and check that it is oil-tight.

Finishing work

- Check the engine oil level. (🔧 p. 179)
- Install the engine guard. (🔧 p. 124)

19.3 Adding engine oil



Info

Too little engine oil or poor-quality engine oil results in premature wear to the engine. The engine may be damaged if the engine oil level is too high.

Condition

The engine is at operating temperature.

Preparatory work

- Stand the motorcycle upright on a horizontal surface.
- Check the engine oil level. (🔧 p. 179)

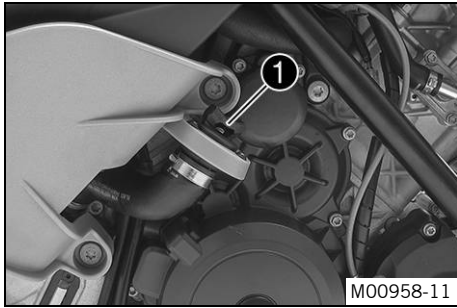

Main work

- Remove screw plug ①.

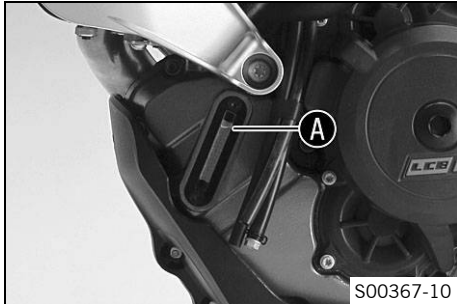

- Add engine oil to the upper marking ① on the engine oil level viewer.

Condition

Outside temperature: $\geq 0\text{ }^{\circ}\text{C}$ ($\geq 32\text{ }^{\circ}\text{F}$)

Engine oil (SAE 10W/50) (☛ p. 208)

Condition

Outside temperature: $< 0\text{ }^{\circ}\text{C}$ ($< 32\text{ }^{\circ}\text{F}$)

Engine oil (SAE 5W/40) (☛ p. 209)



Info

In order to achieve optimal engine performance, it is not advisable to mix different engine oils.

KTM recommends changing the engine oil.

- Mount the screw plug.

**Danger**

Danger of poisoning Exhaust gases are toxic and inhaling them may result in unconsciousness and/or death.

- When running the engine, always make sure there is sufficient ventilation, and do not start or run the engine in an enclosed space without an effective exhaust extraction system.

-
- Start the engine and check that it is oil-tight.

Finishing work

- Check the engine oil level. (👉 p. 179)

20.1 Cleaning motorcycle

Note

Material damage Damage and destruction of components by high-pressure cleaning equipment.

- When cleaning the vehicle with a pressure cleaner, do not point the water jet directly onto electrical components, connectors, cables, bearings, etc. Maintain a minimum distance of 60 cm between the nozzle of the pressure cleaner and the component. Excessive pressure can cause malfunctions or destroy these parts.



Warning

Environmental hazard Hazardous substances cause environmental damage.

- Oil, grease, filters, fuel, cleaners, brake fluid, etc., should be disposed of as stipulated in applicable regulations.



Info

If you clean the motorcycle regularly, its value and appearance will be maintained over a long period.
Avoid direct sunshine on the motorcycle during cleaning.

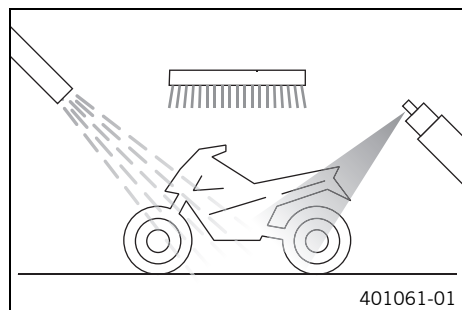

- Close off the exhaust system to keep water from entering.
- First remove coarse dirt particles with a gentle spray of water.
- Spray very dirty areas with a normal motorcycle cleaner and then clean with a brush.

Motorcycle cleaner (☛ p. 211)



Info

Use warm water containing normal motorcycle cleaner and a soft sponge.
Never apply motorcycle cleaner to a dry vehicle; always rinse the vehicle with water first.
If the vehicle was operated in road salt, clean it with cold water. Warm water would enhance the corrosive effects of salt.

- After rinsing the motorcycle with a gentle spray of water, allow it to dry thoroughly.
- Remove the closure of the exhaust system.



Warning

Danger of accidents Reduced braking efficiency due to a wet or dirty brake system.

- Clean or dry a dirty or wet brake system by riding and braking gently.

- After cleaning, ride the vehicle a short distance until the engine warms up.



Info

The heat produced causes water at inaccessible locations in the engine and on the brake system to evaporate.

- Push back the protection caps of the handlebar controls to allow any water that has penetrated to evaporate.
- After the motorcycle has cooled off, lubricate all moving parts and bearings.
- Clean the chain. (🔧 p. 98)
- Treat bare metal parts (except for brake discs and exhaust system) with corrosion inhibitor.

Preserving materials for paints, metal and rubber (🔧 p. 212)

- Treat the painted parts with a mild paint polish.

Perfect Finish and high gloss polish for paints (🔧 p. 212)



Info

Do not polish plastic parts that are matte when the vehicle is delivered as this would seriously impair the material quality.

- Treat the plastic parts and powder-coated parts with a mild cleaning and care product.

Special cleaner for glossy and matte paint finishes, metal and plastic surfaces (☛ p. 212)

- Oil the ignition/steering lock, tank lock, and seat lock.

Universal oil spray (☛ p. 212)

20.2 Checks and maintenance steps for winter operation

i Info

If you use the motorcycle in winter, you must expect salt on the roads. You should therefore take precautions against aggressive road salt.

If the vehicle was operated in road salt, clean it with cold water after riding. Warm water would enhance the corrosive effects of salt.

- Clean the motorcycle. (☛ p. 187)
- Clean the brakes.

i Info

After **EVERY** trip on salted roads, thoroughly wash the brake calipers and brake linings with cold water and dry carefully. This should be done after the parts are cooled down and while they are installed.

After riding on salted roads, thoroughly wash the motorcycle with cold water and dry it well.

- Treat the engine, the swingarm, and all other bare or galvanized parts (except brake discs) with a wax-based corrosion inhibitor.

i Info

Corrosion inhibitor must not come into contact with the brake discs. This would severely lower the braking effect.

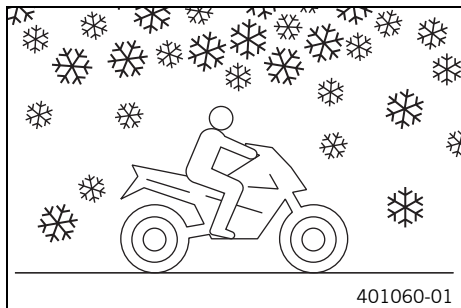

401060-01

- Clean the chain. (👉 p. 98)

21.1 Storage

i Info

If you plan to garage the motorcycle for a longer period, perform the following steps or have them performed. Before storing the motorcycle, check all parts for function and wear. If service, repairs or replacements are necessary, you should do this during the storage period (less workshop overload). In this way, you can avoid long workshop waiting times at the start of the new season.

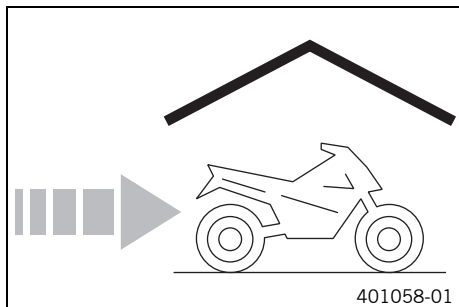

- When refueling for the last time before taking the motorcycle out of service, add fuel additive.

Fuel additive (☞ p. 211)

- Refuel. (☞ p. 85)
- Clean the motorcycle. (☞ p. 187)
- Change the engine oil and oil filter and clean the oil screens. 🛠️ (☞ p. 180)
- Check the coolant fill level and antifreeze. 🛠️
- Check the tire air pressure. (☞ p. 148)
- Remove the battery. 🛠️ (☞ p. 150)

Guideline

Storage temperature of battery without direct sunshine	0... 35 °C (32... 95 °F)
--	--------------------------

- Recharge the battery. 🛠️ (☞ p. 153)
- Store the vehicle in a dry location that is not subject to large fluctuations in temperature.
- Cover the vehicle with a tarp or similar cover that is permeable to air.

i **Info**

Do not use non-porous materials since they prevent humidity from escaping, thus causing corrosion.

Avoid running the engine for a short time only. Since the engine cannot warm up properly, the water vapor produced during combustion condenses and causes valves and the exhaust system to rust.

21.2 Preparing for use after storage

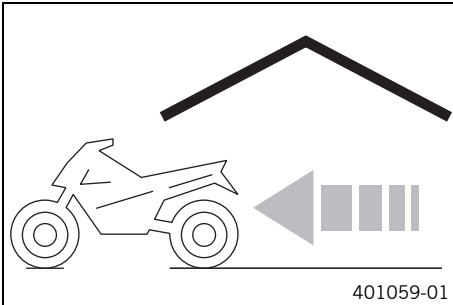

- Install the battery. (🔧 (📖 p. 152))

i **Info**

If the battery was removed, the time and date must be set.

- Perform checks and maintenance measures when preparing for use. (📖 p. 75)
- Take a test ride.

Faults	Possible cause	Action
Combination instrument shows nothing on the display	Fuse 1 blown	– Change the fuses in the fuse box. (☞ p. 159)
	Main fuse burned out	– Change the main fuse. (☞ p. 157)
	The battery is discharged	– Recharge the battery. ☞ (☞ p. 153) – Check the quiescent current. ☞
	Ignition/steering lock is faulty	– Check the ignition/steering lock. ☞
Engine does not crank when the electric starter button is pressed	Emergency OFF switch is off	– Press the emergency OFF switch to the position ON ○.
	Operating error	– Carry out the start procedure. (☞ p. 76)
	The battery is discharged	– Recharge the battery. ☞ (☞ p. 153) – Check the quiescent current. ☞
	Safety start system is faulty	– Read out the fault memory using the KTM diagnostics tool. ☞
	ICU is not enabled	– Activate the ICU. ☞
	CAN bus communication error	– Read out the fault memory using the KTM diagnostics tool. ☞
	Fault in EFI control unit.	– Read out the fault memory using the KTM diagnostics tool. ☞
	Fault in MCU control unit.	– Read out the fault memory using the KTM diagnostics tool. ☞
Engine turns only if the clutch lever is drawn	The vehicle is in gear	– Shift the transmission to idle N .
	Safety start system is faulty	– Read out the fault memory using the KTM diagnostics tool. ☞
Engine turns although a gear is engaged	Safety start system is faulty	– Read out the fault memory using the KTM diagnostics tool. ☞
Engine turns but does not start	The plug-in connection of the fuel hose connection is not connected	– Connect the plug-in connection of the fuel line.

Faults	Possible cause	Action
Engine turns but does not start	Fault in fuel injection system	– Read out the fault memory using the KTM diagnostics tool. 🛠️
	Fuel quality is insufficient	– Add suitable fuel.
Engine dies during the trip	Lack of fuel	– Refuel. (🔧 p. 85)
	Fault in fuel injection system	– Read out the fault memory using the KTM diagnostics tool. 🛠️
The engine warning lamp lights up/flashes	Fault in fuel injection system	– Read out the fault memory using the KTM diagnostics tool. 🛠️
The ABS warning lamp lights up	ABS fuse is blown	– Change the fuses in the fuse box. (🔧 p. 159)
	Wheel speeds of front and rear wheels differ greatly	– Stop, switch off the ignition, start again.
	Malfunction in ABS	– Read out the fault memory using the KTM diagnostics tool. 🛠️
High oil consumption	Engine oil level too high	– Check the engine oil level. (🔧 p. 179)
	Engine oil too thin (low viscosity)	– Change the engine oil and oil filter and clean the oil screens. 🛠️ (🔧 p. 180)
The battery is discharged	The hazard warning flasher is switched on	– Switch off the hazard warning flasher. – Recharge the battery. 🛠️ (🔧 p. 153)
	Battery is not charged by alternator	– Check the charging voltage. 🛠️
	Ignition was not switched off when vehicle was parked	– Recharge the battery. 🛠️ (🔧 p. 153)

23.1 Engine

Design	2-cylinder 4-stroke Otto engine, 75° V arrangement, water-cooled
Displacement	1,050 cm ³ (64.08 cu in)
Stroke	63 mm (2.48 in)
Bore	103 mm (4.06 in)
Compression ratio	13.0:1
Idle speed	1,300... 1,500 rpm
Control	DOHC, 4 valves per cylinder, chain-driven
Valve - valve plate diameter	
Intake	42 mm (1.65 in)
Exhaust	34 mm (1.34 in)
Valve clearance	
Exhaust at: 20 °C (68 °F)	0.25... 0.30 mm (0.0098... 0.0118 in)
Intake at: 20 °C (68 °F)	0.10... 0.15 mm (0.0039... 0.0059 in)
Crankshaft bearing	Sleeve bearing
Conrod bearing	Sleeve bearing
Piston	Forged light alloy
Piston ring	1 upper compression (rectangular) ring, 1 lower compression ring, 1 oil scraper ring
Engine lubrication	Pressure circulation lubrication with three rotary pumps
Primary transmission	40:76
Clutch	Antihopping clutch in oil bath/hydraulically operated
Transmission	6-speed claw gears
Transmission ratio	

1st gear	12:35
2nd gear	15:32
3rd gear	18:30
4th gear	20:27
5th gear	24:27
6th gear	27:26
Mixture preparation	Electronically controlled fuel injection
Ignition system	Contactless controlled fully electronic ignition with digital ignition adjustment
Alternator	12 V, 450 W
Spark plug	
Inside spark plug	NGK LKAR9BI-10
Outside spark plug	NGK LMAR7DI-10
Electrode gap, spark plug	1.0 mm (0.039 in)
Cooling	Water cooling, permanent circulation of coolant by water pump
Cold start device	Electric starter

23.2 Engine tightening torques

Screw, damping plate	EJOT Altracs® M6x14	10 Nm (7.4 lbf ft)	Loctite® 243™
Screw, retaining bracket, valve cover, rear	EJOT Altracs® M6x10	10 Nm (7.4 lbf ft)	–
Hose clip, intake flange	M4	1.5 Nm (1.11 lbf ft)	–
Oil nozzle	M5	2 Nm (1.5 lbf ft)	Loctite® 243™
Remaining engine screws	M5	6 Nm (4.4 lbf ft)	–
Screw, bearing retainer	M5	6 Nm (4.4 lbf ft)	Loctite® 243™

23 TECHNICAL DATA

Screw, bearing shells retaining bracket	M5	6 Nm (4.4 lbf ft)	Loctite® 243™
Screw, engine oil level viewer	M5	4 Nm (3 lbf ft)	–
Screw, gear sensor	M5	6 Nm (4.4 lbf ft)	Loctite® 243™
Screw, pulse generator	M5	6 Nm (4.4 lbf ft)	Loctite® 243™
Bleeder screw, water pump cover	M6	10 Nm (7.4 lbf ft)	–
Freewheel ring bolt	M6 – 10.9	15 Nm (11.1 lbf ft)	Loctite® 648™
Nut, cylinder head	M6	9 Nm (6.6 lbf ft)	–
Plug, vacuum connection	M6	5 Nm (3.7 lbf ft)	Loctite® 243™
Remaining engine screws	M6	10 Nm (7.4 lbf ft)	–
Screw, camshaft bearing support	M6 – 10.9	10 Nm (7.4 lbf ft)	–
Screw, clutch cover	M6	10 Nm (7.4 lbf ft)	–
Screw, clutch spring	M6	12 Nm (8.9 lbf ft)	–
Screw, coolant connection on cylinder head	M6	10 Nm (7.4 lbf ft)	–
Screw, engine case	M6x60	10 Nm (7.4 lbf ft)	–
Screw, engine case	M6x80	10 Nm (7.4 lbf ft)	–
Screw, engine case	M6x90	10 Nm (7.4 lbf ft)	–
Screw, freewheel holder	M6	10 Nm (7.4 lbf ft)	Loctite® 243™
Screw, locking lever	M6	10 Nm (7.4 lbf ft)	Loctite® 243™
Screw, oil pump cover	M6	10 Nm (7.4 lbf ft)	Loctite® 243™
Screw, shift drum locating	M6	10 Nm (7.4 lbf ft)	Loctite® 243™
Screw, shift lever	M6	18 Nm (13.3 lbf ft)	Loctite® 243™
Screw, starter motor	M6	10 Nm (7.4 lbf ft)	–
Screw, stator	M6	10 Nm (7.4 lbf ft)	Loctite® 243™
Screw, valve cover	M6	10 Nm (7.4 lbf ft)	–

23 TECHNICAL DATA

Screw, water pump cover	M6	10 Nm (7.4 lbf ft)	–
Screw, water pump wheel	M6	10 Nm (7.4 lbf ft)	Loctite® 243™
Stud, chain shaft	M6	8 Nm (5.9 lbf ft)	–
Nozzle 100	M6x0.75	4 Nm (3 lbf ft)	Loctite® 243™
Plug, crankshaft retainer	M8	15 Nm (11.1 lbf ft)	–
Screw, camshaft bearing support	M8 – 10.9	Step 1 10 Nm (7.4 lbf ft) Step 2 18 Nm (13.3 lbf ft)	–
Screw, camshaft bearing support	M8 – 10.9	Step 1 8.5 Nm (6.27 lbf ft) Step 2 14.5 Nm (10.7 lbf ft)	Only applies when using: Hex key bit (61229025000)
Screw, engine case	M8	18 Nm (13.3 lbf ft)	–
Screw, timing chain guide rail	M8	15 Nm (11.1 lbf ft)	Loctite® 243™
Stud, exhaust flange	M8	10 Nm (7.4 lbf ft)	–
Timing chain tensioning rail screw	M8	15 Nm (11.1 lbf ft)	Loctite® 243™
Screw, engine bearer	M10	45 Nm (33.2 lbf ft)	–
Oil pressure sensor	M10x1	10 Nm (7.4 lbf ft)	–
Plug, cam lever axis	M10x1	15 Nm (11.1 lbf ft)	–
Plug, clutch lubrication	M10x1	10 Nm (7.4 lbf ft)	–
Screw, conrod bearing	M10x1	Step 1 25 Nm (18.4 lbf ft) Step 2 30 Nm (22.1 lbf ft) Step 3 90°	–

Screw, timing chain tensioner release	M10x1	10 Nm (7.4 lbf ft)	–
Spark plug	M10x1	11 Nm (8.1 lbf ft)	–
Cylinder head screw	M11x1.5	Tightening sequence: Using a crisscross pattern Step 1 15 Nm (11.1 lbf ft) Step 2 30 Nm (22.1 lbf ft) Step 3 90° Step 4 90°	Lubricated with engine oil
Coolant temperature sensor	M12x1.5	12 Nm (8.9 lbf ft)	–
Rotor screw	M12x1.5	115 Nm (84.8 lbf ft)	–
Spark plug	M12x1.5	18 Nm (13.3 lbf ft)	–
Nut of engine sprocket	M20x1.5	100 Nm (73.8 lbf ft)	Loctite® 243™
Oil drain plug	M20x1.5	20 Nm (14.8 lbf ft)	–
Nut, inner clutch hub	M22x1.5	120 Nm (88.5 lbf ft)	Loctite® 243™
Plug, timing-chain tensioner	M24x1.5	25 Nm (18.4 lbf ft)	–
Screw in alternator cover	M24x1.5	8 Nm (5.9 lbf ft)	–
Nut, primary gear	M33LHx1.5	130 Nm (95.9 lbf ft)	Loctite® 243™

23.3 Capacities

23.3.1 Engine oil

Engine oil	3.60 l (3.8 qt.)	Outside temperature: ≥ 0 °C (≥ 32 °F)	Engine oil (SAE 10W/50) (☛ p. 208)
------------	------------------	--	---------------------------------------

Engine oil	3.60 l (3.8 qt.)	Outside temperature: < 0 °C (< 32 °F)	Engine oil (SAE 5W/40) (☛ p. 209)
------------	------------------	---------------------------------------	-----------------------------------

23.3.2 Coolant

Coolant	2.40 l (2.54 qt.)	Coolant (☛ p. 208)
---------	-------------------	--------------------

23.3.3 Fuel

Fuel reserve, approx.	3.5 l (3.7 qt.)
Total fuel tank capacity, approx.	23 l (6.1 US gal) Super unleaded (ROZ 95/RON 95/PON 91) (☛ p. 210)

23.4 Chassis

Frame	Lattice frame made of chrome molybdenum steel tubing, powder-coated
Fork	WP Performance Systems ROMA 4357 upside down
Shock absorber	WP Performance Systems 4618 Emulsion
Suspension travel	
Front	185 mm (7.28 in)
Rear	190 mm (7.48 in)
Brake system	
Front	Double disc brake with radially mounted four-pot brake calipers, floating brake discs
Rear	Single disc brake with dual-piston brake caliper, floating brake disc
Brake discs - diameter	

Front	320 mm (12.6 in)
Rear	267 mm (10.51 in)
Brake discs - wear limit	
Front	4 mm (0.16 in)
Rear	4.5 mm (0.177 in)
Tire air pressure, solo/with passenger/full payload	
Front: with cold tires	2.4 bar (35 psi)
Rear: with cold tires	2.9 bar (42 psi)
Secondary drive ratio	17:42
Chain	5/8 x 5/16" (525) X-ring
Steering head angle	64°
Wheelbase	1,560±15 mm (61.42±0.59 in)
Seat height, unloaded	850 mm (33.46 in)
Ground clearance, unloaded	220 mm (8.66 in)
Weight without fuel, approx.	212 kg (467 lb.)
Maximum permissible front axle load	159 kg (351 lb.)
Maximum permissible rear axle load	281 kg (619 lb.)
Maximum permissible total weight	440 kg (970 lb.)

23.5 Electrical system

Battery	YTZ14S	Battery voltage: 12 V Nominal capacity: 11.2 Ah maintenance-free
Fuse	58011109110	10 A
Fuse	58011109115	15 A

Fuse	58011109125	25 A
Fuse	58011109130	30 A
Low beam	H11/socket PGJ19-2	12 V 55 W
High beam	H11/socket PGJ19-2	12 V 55 W
Parking light	LED	
Instrument lights and indicator lamps	LED	
Turn signal	RY10W / socket BAU15s	12 V 10 W
Tail light	LED	
Brake light	LED	
License plate lamp	LED	

23.6 Tires

Front tires	Rear tires
110/80 R 19 M/C 59V TL Metzeler Tourance NEXT	150/70 R 17 M/C 69V TL Metzeler Tourance NEXT
Additional information is available in the Service section under: http://www.ktm.com	

23.7 Fork

Fork part number	05.18.60.08
Fork	WP Performance Systems ROMA 4357 upside down
Spring length with preload spacer(s)	460 mm (18.11 in)

Spring rate		
Medium (standard)	6 N/mm (34 lb/in)	
Fork length	886.5 mm (34.902 in)	
Air chamber length	47 mm (1.85 in)	
Fork oil per fork leg	570 ml (19.27 fl. oz.)	Fork oil (SAE 4) (48601166S1) (☛ p. 209)

23.8 Shock absorber

Shock absorber article number	01.18.90.08	
Shock absorber	WP Performance Systems 4618 Emulsion	
Rebound damping		
Standard	12 clicks	
Spring preload		
Standard	2 turns	
Spring preload		
Standard	10 mm (0.39 in)	
Spring rate		
Medium (standard)	170 N/mm (971 lb/in)	
Spring length	205 mm (8.07 in)	
Static sag	25 mm (0.98 in)	
Fitted length	402 mm (15.83 in)	
Shock absorber fluid (☛ p. 210)	SAE 2.5	

23.9 Chassis tightening torques

Screw, combination switch, left	M4	2 Nm (1.5 lbf ft)	–
Screw, side stand switch	M4	2 Nm (1.5 lbf ft)	–
Remaining screws, chassis	M5	5 Nm (3.7 lbf ft)	–
Screw brake line holder on frame	M5	2 Nm (1.5 lbf ft)	–
Screw, brake line holder on swingarm	M5	5 Nm (3.7 lbf ft)	–
Screw, cable channel	M5	5 Nm (3.7 lbf ft)	–
Screw, cable guide, wheel speed sensor, rear	M5	3 Nm (2.2 lbf ft)	–
Screw, chain sliding guard	M5	5 Nm (3.7 lbf ft)	–
Screw, combination switch, right	M5	3.5 Nm (2.58 lbf ft)	–
Screw, cover part	M5	3.5 Nm (2.58 lbf ft)	–
Screw, filler cap	M5	3 Nm (2.2 lbf ft)	–
Screw, foot brake lever stub	M5	6 Nm (4.4 lbf ft)	Loctite® 243™
Screw, fuel level sensor	M5	3 Nm (2.2 lbf ft)	–
Screw, heat guard on main silencer	M5	4 Nm (3 lbf ft)	–
Screw, wind shield	M5	3.5 Nm (2.58 lbf ft)	–
Ground fitting on frame	M6	6 Nm (4.4 lbf ft)	–
Nut, ABS unit fixation	M6	8 Nm (5.9 lbf ft)	–
Remaining chassis nuts	M6	10 Nm (7.4 lbf ft)	–
Remaining chassis screws	M6	10 Nm (7.4 lbf ft)	–
Screw, angle sensor	M6	6 Nm (4.4 lbf ft)	–
Screw, ball joint of push rod on foot brake cylinder	M6	10 Nm (7.4 lbf ft)	Loctite® 243™

Screw, battery terminal	M6	4.5 Nm (3.32 lbf ft)	–
Screw, brake line holder on bottom triple clamp	M6	10 Nm (7.4 lbf ft)	–
Screw, cable channel	M6	5 Nm (3.7 lbf ft)	–
Screw, chain guide	M6	5 Nm (3.7 lbf ft)	–
Screw, clutch assembly	M6	5 Nm (3.7 lbf ft)	–
Screw, cooler retaining bracket	M6	7 Nm (5.2 lbf ft)	–
Screw, cover part	M6	6 Nm (4.4 lbf ft)	–
Screw, engine guard	M6	10 Nm (7.4 lbf ft)	–
Screw, exhaust clamp	M6	8 Nm (5.9 lbf ft)	–
Screw, foot brake cylinder	M6	10 Nm (7.4 lbf ft)	Loctite® 243™
Screw, front brake disc	M6	14 Nm (10.3 lbf ft)	Loctite® 243™
Screw, fuel pump	M6	6 Nm (4.4 lbf ft)	–
Screw, fuel tank	M6	10 Nm (7.4 lbf ft)	–
Screw, fuel tap	M6	6 Nm (4.4 lbf ft)	–
Screw, lower rear part	M6	6 Nm (4.4 lbf ft)	–
Screw, magnetic holder on side stand	M6	6 Nm (4.4 lbf ft)	Loctite® 243™
Screw, rear brake disc	M6	14 Nm (10.3 lbf ft)	Loctite® 243™
Screw, retaining bracket, angle sensor	M6	6 Nm (4.4 lbf ft)	Loctite® 243™
Screw, voltage regulator	M6	6 Nm (4.4 lbf ft)	–
Screw, wheel speed sensor, front	M6	10 Nm (7.4 lbf ft)	–
Screw, wheel speed sensor, rear	M6	10 Nm (7.4 lbf ft)	–
Remaining chassis nuts	M8	25 Nm (18.4 lbf ft)	–
Remaining chassis screws	M8	25 Nm (18.4 lbf ft)	–
Screw, bottom triple clamp	M8	12 Nm (8.9 lbf ft)	–

Screw, exhaust clamp	M8	25 Nm (18.4 lbf ft)	–
Screw, foot brake lever	M8	25 Nm (18.4 lbf ft)	Loctite® 243™
Screw, fork stub	M8	15 Nm (11.1 lbf ft)	–
Screw, front footrest bracket	M8	25 Nm (18.4 lbf ft)	Loctite® 243™
Screw, handlebar clamp	M8	20 Nm (14.8 lbf ft)	–
Screw, ignition lock (tamper-proof screw)	M8	25 Nm (18.4 lbf ft)	Loctite® 243™
Screw, rear footrest bracket	M8	25 Nm (18.4 lbf ft)	Loctite® 243™
Screw, steering damper	M8	25 Nm (18.4 lbf ft)	Loctite® 243™
Screw, steering damper clamp	M8	12 Nm (8.9 lbf ft)	–
Screw, suitcase hook	M8	20 Nm (14.8 lbf ft)	Loctite® 243™
Screw, top triple clamp	M8	15 Nm (11.1 lbf ft)	–
Engine carrying screw	M10	45 Nm (33.2 lbf ft)	–
Remaining chassis nuts	M10	45 Nm (33.2 lbf ft)	–
Remaining chassis screws	M10	45 Nm (33.2 lbf ft)	–
Screw, front brake caliper	M10	45 Nm (33.2 lbf ft)	Loctite® 243™
Screw, handlebar support	M10	40 Nm (29.5 lbf ft)	Loctite® 243™
Screw, side stand	M10	35 Nm (25.8 lbf ft)	Loctite® 243™
Screw, side stand bracket	M10	45 Nm (33.2 lbf ft)	Loctite® 243™
Banjo bolt, brake line	M10x1	25 Nm (18.4 lbf ft)	–
Lambda sensor	M12x1.25	25 Nm (18.4 lbf ft)	–
Screw, bottom shock absorber	M14x1.5	80 Nm (59 lbf ft)	Thread greased
Screw, top shock absorber	M14x1.5	80 Nm (59 lbf ft)	Thread greased
Nut, swingarm pivot	M19x1.5	130 Nm (95.9 lbf ft)	Thread greased
Screw, steering head, top	M22x1.5	50 Nm (36.9 lbf ft)	–

23 TECHNICAL DATA

Nut, rear wheel spindle	M25x1.5	90 Nm (66.4 lbf ft)	Thread greased
Screw, front wheel spindle	M25x1.5	45 Nm (33.2 lbf ft)	Thread greased
Nut, steering head, top	M28x1.0	Step 1 10 Nm (7.4 lbf ft) Step 2 (loosen, counterclock- wise) 60°	–

Brake fluid DOT 4 / DOT 5.1

Standard/classification

- DOT

Guideline

- Use only brake fluid that complies with the specified standard (see specifications on the container) and that exhibits the corresponding properties.

Recommended supplier

Castrol

- **RESPONSE BRAKE FLUID SUPER DOT 4**

Motorex®

- **Brake Fluid DOT 5.1**

Coolant

Guideline

- Only use high quality coolant with corrosion inhibitor for aluminum motors (even in countries with high temperatures). Using inferior antifreeze can result in corrosion and foaming.

Mixture ratio

Antifreeze protection: -25... -45 °C (-13... -49 °F)	anti-corrosion/antifreeze distilled water
--	--

Recommended supplier

Motorex®

- **COOLANT M3.0**

Engine oil (SAE 10W/50)

Standard/classification

- JASO T903 MA (☛ p. 213)
- SAE (☛ p. 213) (SAE 10W/50)

Guideline

- Use only engine oils that comply with the specified standards (see specifications on the container) and that possess the corresponding properties.

Fully synthetic engine oil

Recommended supplier

Motorex®

- Power Synt 4T

Engine oil (SAE 5W/40)

Standard/classification

- JASO T903 MA (☛ p. 213)
- SAE (☛ p. 213) (SAE 5W/40)

Guideline

- Use only engine oils that comply with the specified standards (see specifications on the container) and that possess the corresponding properties.

Synthetic engine oil

Recommended supplier

Motorex®

- Power Synt 4T

Fork oil (SAE 4) (48601166S1)

Standard/classification

- SAE (☛ p. 213) (SAE 4)

Guideline

- Use only oils that comply with the specified standards (see specifications on the container) and that exhibit the corresponding properties.

Shock absorber fluid (SAE 2.5) (50180751S1)

Standard/classification

- SAE (☛ p. 213) (SAE 2.5)

Guideline

- Use only oils that comply with the specified standards (see specifications on the container) and that exhibit the corresponding properties.

Super unleaded (ROZ 95/RON 95/PON 91)

Standard/classification

- DIN EN 228 (ROZ 95/RON 95/PON 91)

Guideline

- Only use unleaded super fuel that matches or is equivalent to the specified fuel grade.
- Fuel with an ethanol content of up to 10 % (E10 fuel) is safe to use.



Info

Do **not** use fuel containing methanol (e. g. M15, M85, M100) or more than 10 % ethanol (e. g. E15, E25, E85, E100).

Chain cleaner

Recommended supplier

Motorex®

- Chain Clean

Chain lube for road use

Guideline

Recommended supplier

Motorex®

- Chainlube Road

Fuel additive

Recommended supplier

Motorex®

- Fuel Stabilizer

Long-life grease

Recommended supplier

Motorex®

- Bike Grease 2000

Motorcycle cleaner

Recommended supplier

Motorex®

- Moto Clean

Perfect Finish and high gloss polish for paints

Recommended supplier

Motorex®

- Moto Polish & Shine

Preserving materials for paints, metal and rubber

Recommended supplier

Motorex®

- Moto Protect

Special cleaner for glossy and matte paint finishes, metal and plastic surfaces

Recommended supplier

Motorex®

- Quick Cleaner

Universal oil spray

Recommended supplier

Motorex®

- Joker 440 Synthetic

JASO T903 MA

Different technical development directions required a new specification for 4-stroke motorcycles – the JASO T903 MA Standard. Earlier, engine oils from the automobile industry were used for 4-stroke motorcycles because there was no separate motorcycle specification. Whereas long service intervals are demanded for automobile engines, high performance at high engine speeds are in the foreground for motorcycle engines. In most motorcycles, the gearbox and the clutch are lubricated with the same oil as the engine. The JASO MA Standard meets these special requirements.

SAE

The SAE viscosity classes were defined by the Society of Automotive Engineers and are used for classifying oils according to their viscosity. The viscosity describes only one property of oil and says nothing about quality.



ABS	ABS	Safety system that prevents locking of the wheels when driving straight ahead without the influence of lateral forces
ATIR	Automatic Turn Indicator Reset	Software, which automatically switches the indicator off according to a time or travel distance counter
DRL	Daytime Running Light	Light, which enhances the visibility of the vehicle during the day but is not focused, and in contrast to low beam does not illuminate the road surface
TC	Traction Control	Auxiliary function of the motor control that reduces engine torque with spinning rear wheel

28 LIST OF ABBREVIATIONS

Art. no.	Article number
ca.	circa
cf.	compare
e.g.	for example
etc.	et cetera
i.a.	inter alia
no.	number
poss.	possibly





29.1 Red symbols

Red symbols indicate an error condition that requires immediate intervention.

	The immobilizer indicator lamp lights up or flashes red – Status or error message for immobilizer/alarm system.
	The oil pressure warning lamp lights up red – Engine oil pressure is too low.

29.2 Yellow and orange symbols

Yellow and orange symbols indicate an error condition that requires prompt intervention. Active driving aids are also represented by yellow or orange symbols.



	The general warning lamp lights up yellow – An operating safety (warning) message was detected. This is also shown on the matrix display.
	The engine warning lamp lights up/flashes yellow – The engine control unit has detected a fault.
	The ABS lamp lights up/flashes yellow – ABS is not active. The ABS lamp also lights up when an error is detected.
	The TC lamp lights up/flashes yellow – Traction control is not enabled or is currently intervening. The TC lamp also lights up when an error is detected.

29.3 Green and blue symbols

Green and blue symbols reflect information.

	The high beam indicator lamp lights up blue – The high beam is switched on.
---	---

29 LIST OF SYMBOLS

	The left turn signal lamp flashes green simultaneously with the turn signal – The left turn signal is switched on.
	The idle indicator lamp lights up green – The transmission is shifted to idle.
	The right turn signal lamp flashes green simultaneously with the turn signal – The right turn signal is switched on.

A

ABS	125
Accessories	15
Auxiliary substances	15

B

Battery	
installing	152
recharging	153
removing	150
Brake discs	
checking	126
Brake fluid	
front brake, adding	128
rear brake, adding	132
Brake fluid level	
front brake, checking	127
rear brake, checking	131
Brake linings	
front brake, checking	130
rear brake, checking	133
Brake system	125-134
Brakes	81
Brakes, applying	81

C

Capacity	
coolant	200
engine oil	183, 199-200
fuel	86, 200
Chain	
checking	102
checking for dirt	98
cleaning	98
Chain tension	
adjusting	100
checking	99
Chassis number	22
Clutch	
fluid level, checking/correcting	105
Clutch lever	25
basic position, adjusting	63
Combination instrument	42-52, 54-59
"ABS"	51
activation and test	42
"Clock/Date"	58
"Distance"	56
"Drive Mod"	52, 177
"DRL"	59
"Favorites"	47
"Fuel Cons"	57
"general info"	49

"Heat Grip"	59	Emergency OFF switch	30
"Heating" menu	51	Engine	
indicator lamps	44	running in	72
"Language"	55	Engine guard	
matrix display	43	installing	124
menu overview	54	Engine guards	
message on the matrix display	45	removing	124
"MTC"	51	Engine number	23
overview	42	Engine oil	
"Pressure"	57	adding	184
segment display	43	changing	180
service display	47	Engine oil level	
"Set Favorites"	49	checking	179
"Settings"	50	Engine sprocket	
shift warning light	46	checking	102
"Shift Light"	58	Environment	13
"Temp"	56	F	
"Trip 1"	48	Figures	16
"Trip 2"	48	Filler cap	
"Warning"	50	closing	35
Combination switch	26	opening	33
overview	26	Foot brake lever	41
Coolant level		basic position, adjusting	69
checking in the compensating tank	174	Footrests	
correcting in the compensating tank	175	adjusting	65
Customer service	16		
E			
Electric starter button	30		

Fork	
dust boots, cleaning	118
Fork part number	24
Front fender, front	
installing	117
removing	117
Front wheel	
installing	137
removing	135
Fuel cocks	36
Fuses	
in fuse box, changing	159
G	
Grab handles	38
H	
Hand brake lever	25
basic position, adjusting	64
Handlebar position	60
adjusting	60
Hazard warning flasher	27
Hazard warning flasher switch	27
Headlight	
daytime running light	150
headlight range, adjusting	168
Headlight adjustment	
checking	167
Headlight mask with headlight	
installing	162
removing	161
High beam bulb	
changing	164
Horn button	29
I	
Ignition key	
activating/deactivating	169
Ignition lock	31
immobilizer	31
Intended use	10
K	
Key number	23
L	
Light switch	27
Low beam bulb	
changing	163
Luggage	73
Luggage rack plate	39
M	
Main fuse	
changing	157

Mask spoiler

- installing 114
- removing 112

Matrix display

- menu 47

Motorcycle

- cleaning 187
- lifting with front lifting gear 93
- lifting with rear lifting gear 92
- raising with work stand (inserted) 95
- removing from the work stand (inserted) 96
- removing the rear from the lifting gear 92
- taking from the front lifting gear 94

O

Oil filter

- changing 180

Oil screens

- cleaning 180

Operating substances 15

Owner's Manual 14

P

Parking 83

Passenger footrest 39

Preparing for use

- advice on first use 71
- after storage 192

- checks and maintenance measures when preparing for use . 75

Protective clothing 13

R

Rear hub rubber dampers

- checking 145

Rear sprocket

- checking 102

Rear wheel

- installing 142
- removing 140

Refueling

- fuel 85

Rider footrests 64

Riding 77

- starting off 77

S

Safe operation 12

Seat

- mounting 97
- removing 97

Seat lock 37

Service 16

Service schedule 87-89

Shift lever 40

- basic position, adjusting 68

basic position, checking	67
Shifting	77
Shock absorber	
rebound damping, adjusting	90
spring preload, adjusting	90
Shock absorber article number	24
Side cover, front	
removing	109
Side cover, front,	
installing	110
Side stand	41
Spare parts	15
Starting	76
Steering	
locking	32
unlocking	33
Steering head bearing play	
checking	106
Steering lock	31
Stopping	83
Storage	191
Storage compartment	
closing	37
opening	36
Suspension setting	90-91

Switch

on the left side of the handlebar	26
on the right side of the handlebar	30

T

Tank cover

installing	121
removing	119

TC

	177
--	-----

Technical data

capacities	199
chassis	200
chassis tightening torques	204
electrical system	201
engine	195-207
engine tightening torques	196
fork	202
shock absorber	203
tires	202

Throttle grip

	26
--	----

Tire air pressure

checking	148
----------	-----

Tire condition

checking	147
----------	-----

Tool set

	38
--	----

Traction control

	177
--	-----

Transport

	84
--	----

Triple clamp cover, bottom	
installing	108
removing	107
Troubleshooting	193-194
Turn signal bulb	
changing	166
Turn signal switch	28
Type label	22
U	
Use definition	10
V	
Vehicle	
loading	73
View of vehicle	
front left side	18
rear right side	20
W	
Warranty	15
Wind shield	
adjusting	62
installing	123
removing	123
Winter operation	
checks and maintenance steps	189
Work rules	13

READY TO RACE

[» www.ktm.com](http://www.ktm.com)



3213391en

10/2015

KTM Sportmotorcycle GmbH
3230 Mattighofen/Austria
<http://www.ktm.com>



Photo: Mitterbauer/KTM