

125 SX
150 SX
250 SX
250 XC
300 XC

Art. no. 3213435en



KTM

The work described in these setup instructions must be performed before the vehicle is delivered to the customer.

Read the setup instructions in their entirety before beginning work.

These setup instructions were written to correspond to the latest state of this series. We reserve the right to make changes in the interest of technical advancement without at the same time updating this manual.

We shall not provide a description of general workshop methods. Likewise, safety rules that apply in a workshop are not specified here. It is assumed that the work will be performed by a fully trained mechanic.

All specifications are non-binding. KTM Sportmotorcycle GmbH specifically reserves the right to modify or delete technical specifications, prices, colors, forms, materials, services, designs, equipment, etc., without prior notice and without specifying reasons, to adapt these to local conditions, as well as to stop production of a particular model without prior notice. KTM accepts no liability for delivery options, deviations from illustrations and descriptions, misprints, and other errors. The models portrayed partly contain special equipment that does not belong to the regular scope of supply.

© 2015 KTM Sportmotorcycle GmbH, Mattighofen Austria

All rights reserved

Reproduction, even in part, as well as copying of all kinds, is permitted only with the express written permission of the copyright owner.



ISO 9001(12 100 6061)

According to the international quality management standard ISO 9001, KTM uses quality assurance processes that lead to the maximum possible quality of the products.

Issued by: TÜV Management Service

REG.NO. 12 100 6061

KTM Sportmotorcycle GmbH
5230 Mattighofen, Austria

This document is valid for the following models:

- 125 SX EU (F6101P0)
- 125 SX US (F6175P0)
- 150 SX EU (F6101P1)
- 150 SX US (F6175P1)
- 250 SX EU (F6301P0)
- 250 SX US (F6375P0)
- 250 XC US/EU (F6375P5)
- 300 XC US/EU (F6475P5)



1.1 Symbols used

The meaning of specific symbols is described below.



Indicates an expected reaction (e.g. of a work step or a function).



Indicates an unexpected reaction (e.g. of a work step or a function).



Indicates a page reference (more information is provided on the specified page).



Indicates information with more details or tips.



Indicates the result of a testing step.



Denotes a voltage measurement.



Denotes a current measurement.



Denotes a resistance measurement.

1.2 Formats used

The typographical formats used in this document are explained below.

Proprietary name	Identifies a proprietary name.
Name®	Identifies a protected name.
Brand™	Identifies a trademark.
<u>Underlined terms</u>	Refer to technical details of the vehicle or indicate technical terms, which are explained in the glossary.

2.1 Unpacking and setting up the vehicle

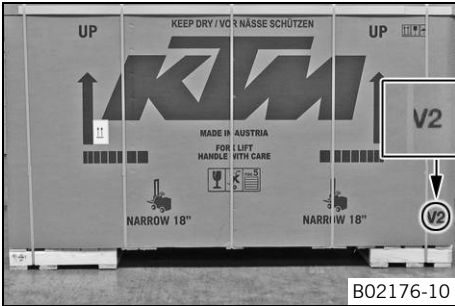

Package 2

- Remove the box and the plastic packaging.

i Info
To avoid damaging the motorcycle during the setup, leave the protective film on the vehicle until you have finished.

- Remove the separate enclosure and unpack it. Check that the scope of supply is complete on the basis of the enclosed packing list.
- Have a lift stand available.

Lift stand (78129955100)

- Carefully loosen and remove the tension belt of the footrest mount.

i Info
An assistant prevents the motorcycle from falling over.

- Together with an assistant, take the vehicle off the palette.
- Position the vehicle on a lift stand.
- Check the vehicle for transport damage.

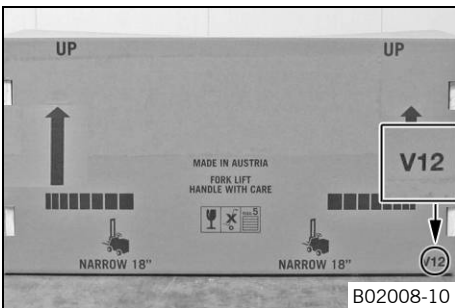
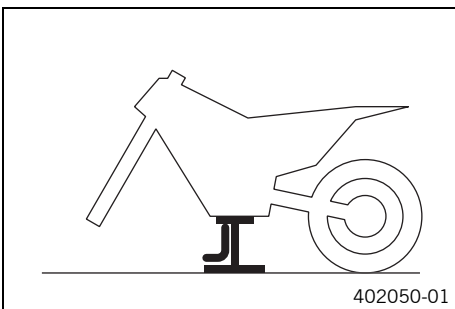

Package 12

- Remove the box and the plastic packaging.

i Info
An assistant prevents the motorcycle from falling over.
To avoid damaging the motorcycle during the setup, leave the protective film on the vehicle until you have finished.

- Remove the separate enclosure and unpack it. Check that the scope of supply is complete on the basis of the enclosed packing list.
- Have a lift stand available.

Lift stand (78129955100)

- Together with an assistant, take the vehicle off the palette.
- Position the vehicle on a lift stand.
- Check the vehicle for transport damage.

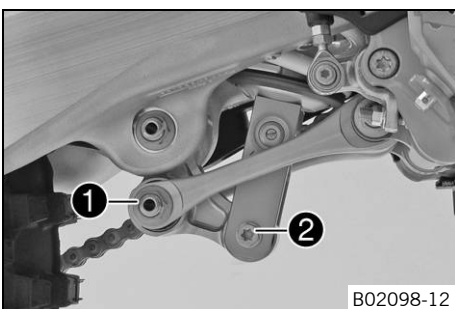
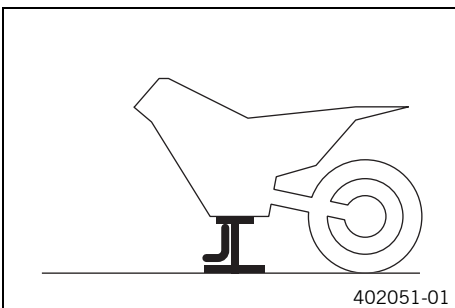

- Remove the cardboard from around the shock absorber.
- Position the angle lever and linkage lever.
- Mount and tighten fitting ①.

Guideline

Nut, frame on linkage lever	M14x1.5	80 Nm (59 lbf ft)
-----------------------------	---------	-------------------

- Mount and tighten screw ②.

Guideline

Screw, bottom shock absorber	M10	60 Nm (44.3 lbf ft)	Loctite® 2701™
------------------------------	-----	---------------------	----------------

- Route the clutch line with the clutch master cylinder toward the front between the upper and lower triple clamps.

(125/150 SX EU)

- Route the clutch line with the clutch master cylinder toward the front between the upper and lower triple clamps.
- Position the fork legs.
 - ✓ Bleeder screw **3** of the right fork leg is positioned to the front.
 - ✓ Left fork leg valve **A** is offset by approx. 20° to the front.

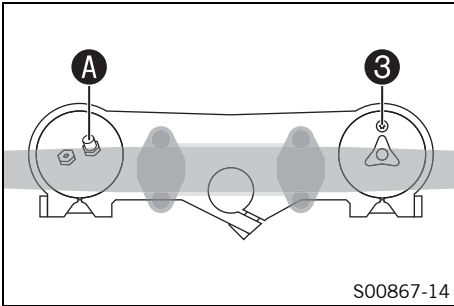

i Info
Grooves are milled into the side of the upper end of the fork legs. The second milled groove (from the top) must be flush with the top edge of the upper triple clamp. The air suspension is located in the left fork leg. The pressure and rebound damping is located in the right fork leg.

- Tighten the screws of the triple clamp.

Guideline

Screw, top triple clamp	M8	17 Nm (12.5 lbf ft)
Screw, bottom triple clamp	M8	12 Nm (8.9 lbf ft)

(125/150 SX US, All 250/300 models)

- Position the fork legs.
 - ✓ Bleeder screws **3** are positioned toward the front.

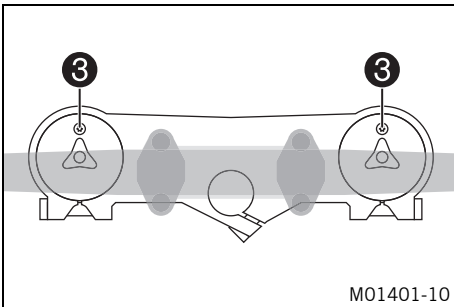

i Info
The rebound damping is located in the right fork leg (red adjusting screw). The compression damping is located in the left fork leg (white adjusting screw). Grooves are milled into the side of the upper end of the fork legs. The second milled groove (from the top) must be flush with the top edge of the upper triple clamp.

- Tighten the screws of the triple clamp.

Guideline

Screw, top triple clamp	M8	17 Nm (12.5 lbf ft)
Screw, bottom triple clamp	M8	12 Nm (8.9 lbf ft)

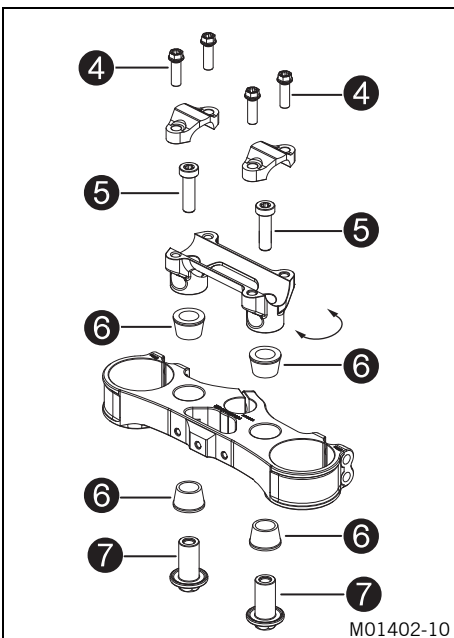

- Remove screws **4**. Take off the handlebar clamps.
- Remove screws **5**. Remove the handlebar support.
- Position rubber bushings **6** and push through nuts **7** from below.
- Place the handlebar support in the required position. Mount and tighten screws **5**.

Guideline

Screw, handlebar support	M10	40 Nm (29.5 lbf ft)	Loctite® 243™
--------------------------	-----	------------------------	----------------------



B02178-01

- Position the handlebar.



Info

Make sure the cables and wiring are positioned correctly.

- Position the handlebar clamps. Mount screws ④. Screw the handlebar clamps so that both parts touch at the front and tighten all of the screws.

Guideline

Screw, handlebar clamp	M8	20 Nm (14.8 lbf ft)
------------------------	----	------------------------

- Position the controls on the right half of the handlebar.

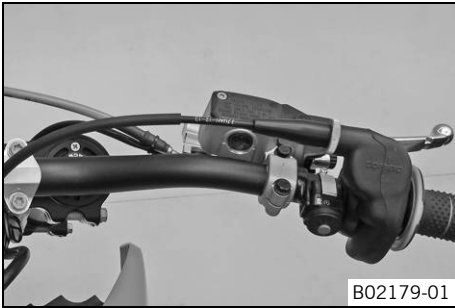

B02179-01

- Position the controls on the left half of the handlebar.



Info

The routing of the cables can be seen in the figure.

- Mount the fuel tank breather correctly.
- Install the front wheel. (☛ p. 8)
- Install the front fender. (☛ p. 9)
- Install the start number plate. (☛ p. 9)
- Mount the handlebar cushion.
- Install the footrests. (☛ p. 8)



B02180-01

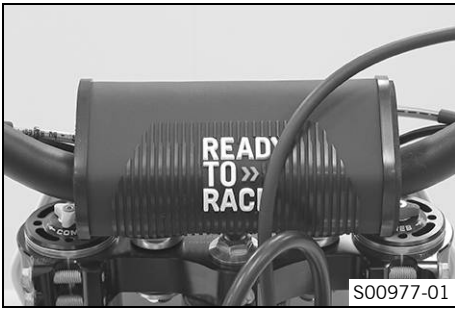

S00977-01



S00978-10

(All XC models)



Warning

Risk of injury Battery acid and battery gases cause serious chemical burns.

- Keep batteries out of the reach of children.
- Wear suitable protective clothing and goggles.
- Avoid contact with battery acid and battery gases.
- Keep sparks and open flames away from the battery. Only charge in well-ventilated rooms.
- In the event of skin contact, rinse with large amounts of water. If battery acid gets in the eyes, rinse with water for at least 15 minutes and contact a physician.

- Fill the battery.



Info

Read the notes in the battery package.

- Recharge the battery. (☛ p. 11)
- Install the battery. (☛ p. 12)

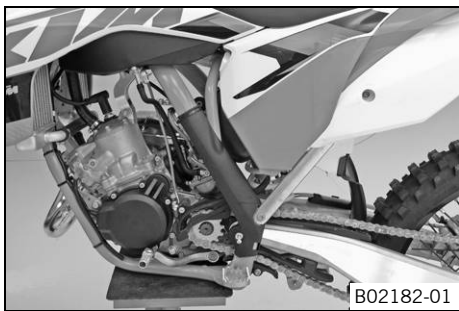

- Unpack and mount the **KTM PowerParts** included in the delivery (optional).

i **Info**

Read the accompanying **KTM PowerParts** fitting instructions.

- Apply the label included in the delivery (optional).
- Refuel. (☛ p. 13)
- Position all controls in their exact positions on the handlebar. Tighten all screws.
- Prepare the vehicle according to the specifications in the **KTM Dealer.net** for hand-over to the customer.

3.1 Raising the motorcycle with a lift stand

Note

Material damage The vehicle may be damaged by incorrect procedure when parking. Significant damage may be caused if the vehicle rolls away or falls over. The components for parking the vehicle are designed only for the weight of the vehicle.

- Park the vehicle on a firm and level surface.
- Ensure that nobody sits on the vehicle when the vehicle is parked on a stand.

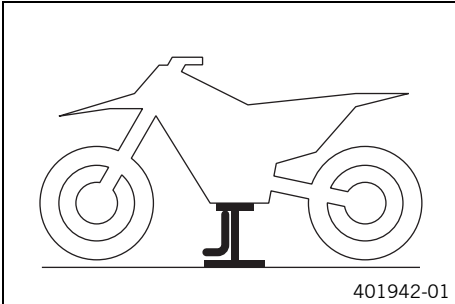

- Raise the motorcycle at the frame underneath the engine.

Lift stand (78129955100)

- ✓ Neither wheel is in contact with the ground.
- Secure the motorcycle against falling over.

3.2 Removing the motorcycle from the lift stand

Note

Material damage The vehicle may be damaged by incorrect procedure when parking. Significant damage may be caused if the vehicle rolls away or falls over. The components for parking the vehicle are designed only for the weight of the vehicle.

- Park the vehicle on a firm and level surface.
- Ensure that nobody sits on the vehicle when the vehicle is parked on a stand.

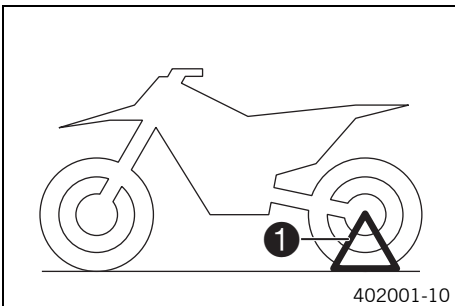

(All SX models)

- Remove the motorcycle from the lift stand.
- Remove the lift stand.
- To park the motorcycle, insert plug-in stand ❶ into the left side of the wheel spindle.

i Info Remove the plug-in stand before riding.

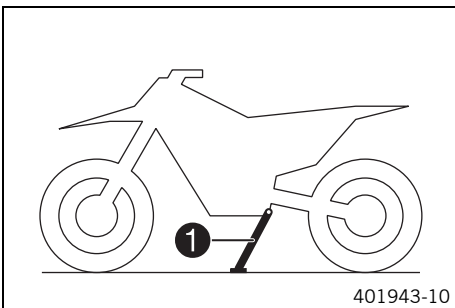

(All XC models)

- Remove the motorcycle from the lift stand.
- Remove the lift stand.
- To park the motorcycle, press side stand ❶ to the ground with your foot and lean the motorcycle on it.

i Info While riding, the side stand must be folded up and secured with the rubber band.

3.3 Installing the front wheel

Warning
Danger of accidents Reduced braking efficiency due to oil or grease on the brake discs.

- Always keep the brake discs free of oil and grease, and clean them with brake cleaner when necessary.

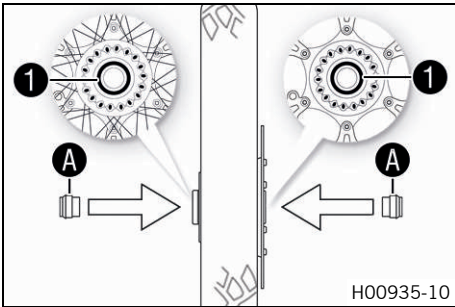

- Check the wheel bearing for damage and wear.
 - » If the wheel bearing is damaged or worn:
 - Change the front wheel bearing.
- Clean and grease shaft seal rings **1** and contact surface **A** of the spacers.

Long-life grease (☛ p. 18)

- Insert the spacers.

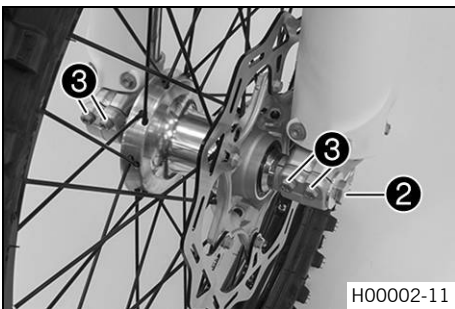

- Lift the front wheel into the fork, position it, and insert the wheel spindle.
 - ✓ The brake linings are correctly positioned.
- Mount and tighten screw **2**.

Guideline

Screw, front wheel spindle	M20x1.5	35 Nm (25.8 lbf ft)
----------------------------	---------	------------------------

- Operate the hand brake lever several times until the brake linings are lying correctly against the brake disc.

- Remove the motorcycle from the lift stand. (☛ p. 7)
- Operate the front brake and compress the fork a few times firmly.
 - ✓ The fork legs straighten.

- Tighten screws **3**.

Guideline

Screw, fork stub	M8	15 Nm (11.1 lbf ft)
------------------	----	------------------------

3.4 Installing the footrests

i Info
 The procedures are the same on both footrests.



Condition

- The frame protectors have been removed on the left and right.

(All 125/150 models)

- Position the new footrest and pin.

i Info
 Only insert the pin to the extent that the spring can still be mounted.

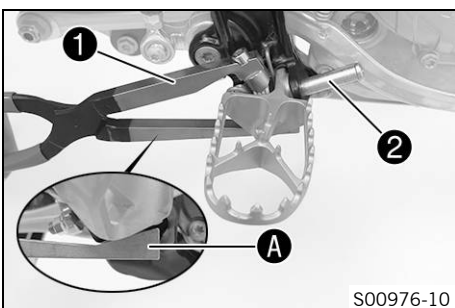

- Press the spring with special tool **1**.

Pliers for footrest spring (79029083000)

- ✓ The special tool is applied to area **A** on the footrest.
- Mount pin **2**.

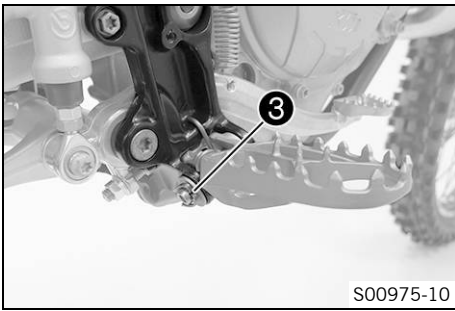

S00975-10

- Mount the washer and split pin ❸.

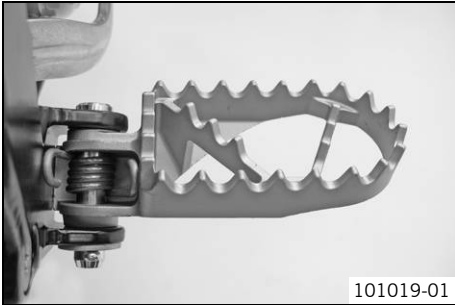

101019-01

(All 250/300 models)

- Mount the footrests with the springs and pins. Secure the pins using the washers and cotter pins.

Pliers for footrest spring (58429083000)

3.5 Installing the front fender

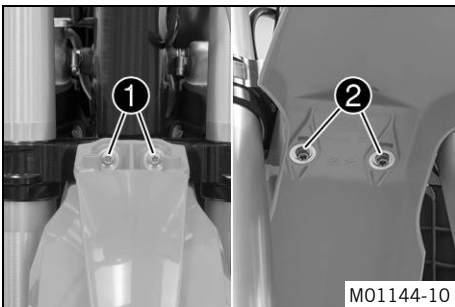

M01144-10

Main work

- Position the front fender. Mount and tighten screws ❶ and ❷.

Guideline

Remaining screws, chassis	M6	10 Nm (7.4 lbf ft)
---------------------------	----	--------------------

Finishing work

- Install the start number plate. (☛ p. 9)

3.6 Installing the start number plate

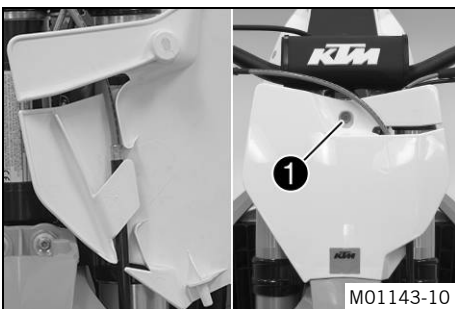

M01143-10

(All 125/150 models)

- Connect the brake line at the start number plate.
- Position the start number plate.
- ✓ The holding lugs engage in the fender.
- Mount and tighten screw ❶.

Guideline

Remaining screws, chassis	M6	10 Nm (7.4 lbf ft)
---------------------------	----	--------------------

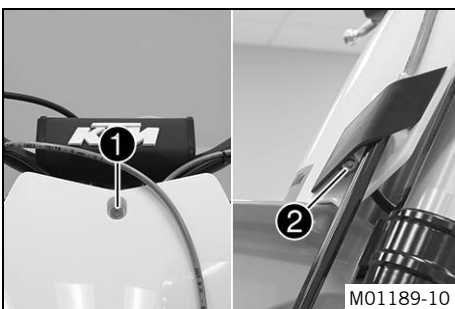

M01189-10

(All 250/300 models)

- Position the start number plate.
- ✓ The holding lugs engage in the fender.
- Mount and tighten screw ❶.

Guideline

Remaining screws, chassis	M6	10 Nm (7.4 lbf ft)
---------------------------	----	--------------------

- Position the brake line and clamp. Mount and tighten screw ❷.

3.7 Removing the seat

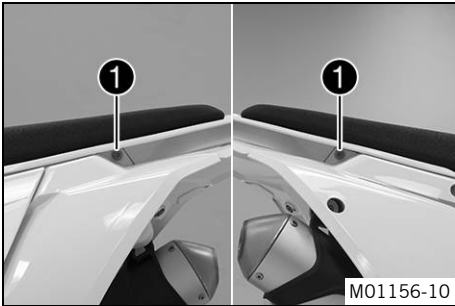

(All 125/150 models)

- Remove screws ①.
- Raise the rear of the seat, pull the seat back, and lift it off.

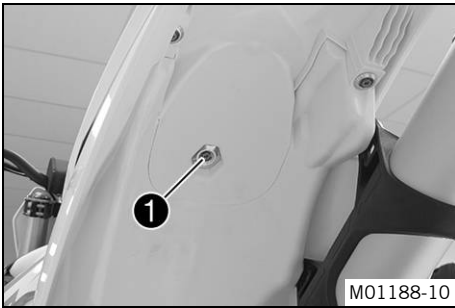

(All 250/300 models)

- Remove screw ①.
- Raise the rear of the seat, pull the seat back, and lift it off.

3.8 Mounting the seat

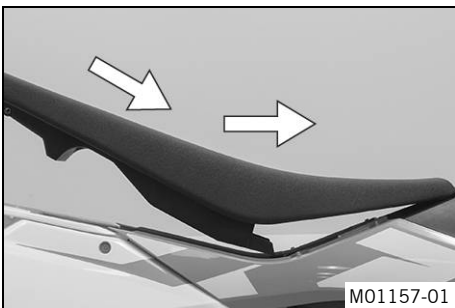

(All 125/150 models)

- Mount the front seat on to the collar bushing of the fuel tank, lower it at the rear, and simultaneously push it forward.
- Make sure that the seat is correctly locked in.

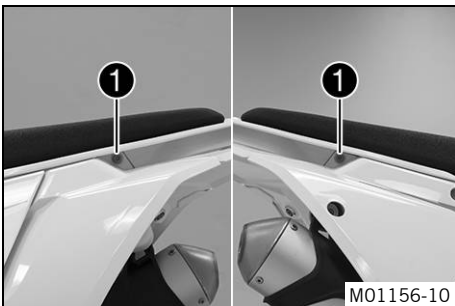

- Mount and tighten screws ①.

Guideline

Remaining screws, chassis	M6	10 Nm (7.4 lbf ft)
---------------------------	----	-----------------------



(All 250/300 models)

- Mount the front seat on to the collar bushing of the fuel tank, lower it at the rear, and simultaneously push it forward.
- Make sure that the seat is correctly locked in.

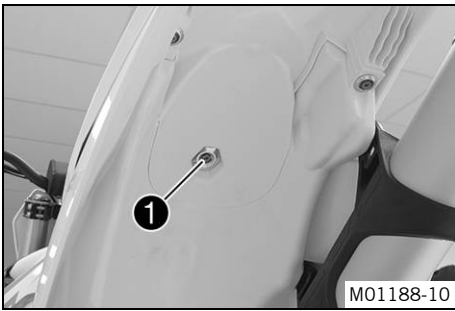

- Mount and tighten screw ①.

Guideline

Remaining screws, chassis	M6	10 Nm (7.4 lbf ft)
---------------------------	----	-----------------------

3.9 Recharging the battery (All XC models)



Warning

Risk of injury Battery acid and battery gases cause serious chemical burns.

- Keep batteries out of the reach of children.
- Wear suitable protective clothing and goggles.
- Avoid contact with battery acid and battery gases.
- Keep sparks and open flames away from the battery. Only charge in well-ventilated rooms.
- In the event of skin contact, rinse with large amounts of water. If battery acid gets in the eyes, rinse with water for at least 15 minutes and contact a physician.



Warning

Environmental hazard The battery contains elements that are harmful to the environment.

- Do not dispose of batteries with the household waste. Dispose of a defective battery in an environmentally friendly manner. Give the battery to your authorized KTM dealer or dispose of it at a collection point for used batteries.



Warning

Environmental hazard Hazardous substances cause environmental damage.

- Oil, grease, filters, fuel, cleaners, brake fluid, etc., should be disposed of as stipulated in applicable regulations.



Info

Even when there is no load on the battery, it discharges steadily.

The charging level and the method of charging are very important for the service life of the battery.

Rapid recharging with a high charging current shortens the service life of the battery.

If the charging current, charging voltage, or charging time is exceeded, electrolyte escapes through the safety valves. This reduces the battery capacity.

If the battery is depleted by repeated starting, the battery must be charged immediately.

If the battery is left in a discharged state for an extended period, it will become over-discharged and sulfated, destroying the battery.

The battery is maintenance-free. The acid level does not have to be checked.

Preparatory work

- Switch off all power consumers and switch off the engine.
- Remove the seat. (☛ p. 10)
- To prevent damage to the onboard electronics, disconnect the negative cable from the battery.

Main work

- Connect the battery charger to the battery. Switch on the battery charger.

Battery charger (58429074000)

In addition, this battery charger can be used to test the quiescent current, the start ability of the battery, and the alternator. With this device, you cannot overcharge the battery.



Info

Never remove lid ①.

Charge the battery to a maximum of 10% of the capacity specified on battery housing ②.

- Switch off the battery charger after charging and disconnect from the battery.

Guideline

The charging current, charging voltage, and charging time must not be exceeded.	
Charge the battery regularly when the motorcycle is not in use	3 months

- Connect the negative cable with the battery.

Finishing work

- Mount the seat. (☛ p. 10)

3.10 Installing the battery (All XC models)

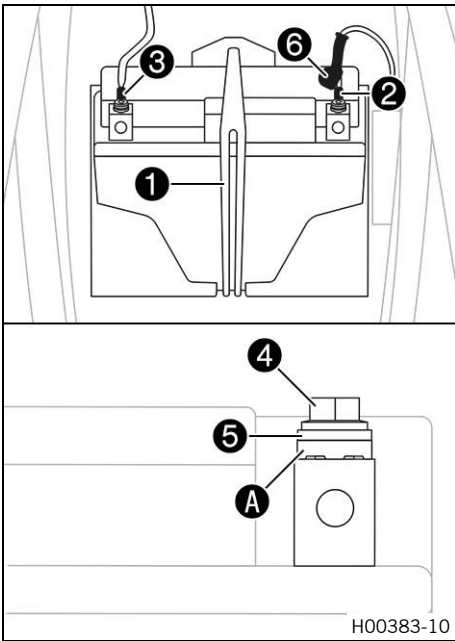

Main work

- Insert the battery into the battery compartment with the terminals facing forward.

Battery (YTX4L-BS)

- Reconnect rubber band 1.
- Position the positive cable 2 and mount and tighten the screw.

Guideline

Screw, battery terminal	M5	2.5 Nm (1.84 lbf ft)
-------------------------	----	-------------------------

Info

Contact disks A must be mounted under screws 4 and cable sockets 5 with the claws toward the battery terminal.

- Slide positive terminal cover 6 over the positive terminal.
- Position negative cable 3 and mount and tighten the screw.

Guideline

Screw, battery terminal	M5	2.5 Nm (1.84 lbf ft)
-------------------------	----	-------------------------

Finishing work

- Mount the seat. (☛ p. 10)

3.11 Opening the filler cap



Danger

Fire hazard Fuel is highly flammable.

- Never refuel the vehicle near open flames or burning cigarettes, and always switch off the engine first. Be careful that no fuel is spilt, especially on hot vehicle components. Clean up spilt fuel immediately.
- The fuel in the fuel tank expands when warm and may emerge if overfilled. Follow the instructions on refueling.



Warning

Danger of poisoning Fuel is poisonous and a health hazard.

- Fuel must not come into contact with the skin, eyes, or clothing. Do not breathe in the fuel vapors. If contact occurs with the eyes, rinse with water immediately and contact a physician. Immediately clean contaminated areas on the skin with soap and water. If fuel is swallowed, contact a physician immediately. Change clothing that has been contaminated with fuel. Store fuel properly in a suitable canister and keep away from children.



Warning

Environmental hazard Improper handling of fuel is a danger to the environment.

- Do not allow fuel to get into the ground water, the ground, or the sewage system.

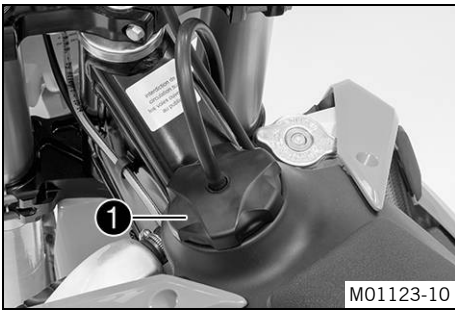

(All SX models)

- Turn filler cap ① counterclockwise and lift it off.

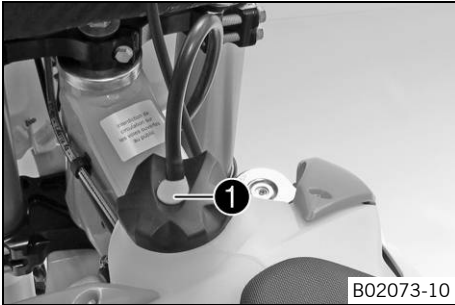

(All XC models)

- Press release button ①, turn the filler cap counterclockwise, and lift it off.

3.12 Closing the filler cap

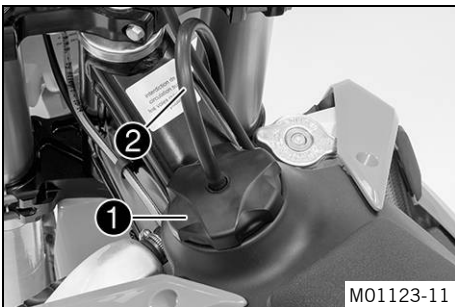

(All SX models)

- Mount filler cap ① and turn it clockwise until the fuel tank is tightly closed.

i Info

Run the fuel tank breather hose ② without kinks.

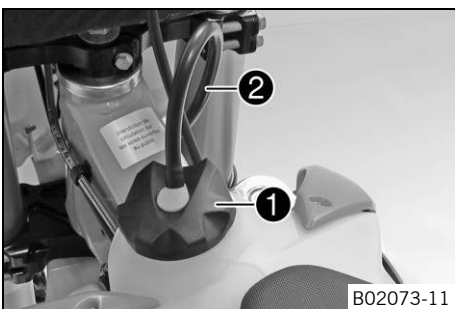

(All XC models)

- Mount filler cap ① and turn it clockwise until the release button engages.

i Info

Run the fuel tank breather hose ② without kinks.

3.13 Refueling



Danger

Fire hazard Fuel is highly flammable.

- Never refuel the vehicle near open flames or burning cigarettes, and always switch off the engine first. Be careful that no fuel is spilt, especially on hot vehicle components. Clean up spilt fuel immediately.
- The fuel in the fuel tank expands when warm and may emerge if overfilled. Follow the instructions on refueling.



Warning

Danger of poisoning Fuel is poisonous and a health hazard.

- Fuel must not come into contact with the skin, eyes, or clothing. Do not breathe in the fuel vapors. If contact occurs with the eyes, rinse with water immediately and contact a physician. Immediately clean contaminated areas on the skin with soap and water. If fuel is swallowed, contact a physician immediately. Change clothing that is contaminated with fuel.



Warning

Environmental hazard Improper handling of fuel is a danger to the environment.

- Do not allow fuel to get into the ground water, the ground, or the sewage system.

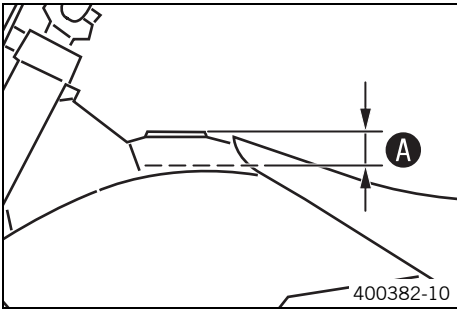

- Switch off the engine.
- Open the filler cap. (☛ p. 12)
- Fill the fuel tank with fuel up to measurement **A**.

Guideline

Measurement of A	35 mm (1.38 in)	
Total fuel tank capacity, approx. (All SX models)	7.5 l (1.98 US gal)	Super unleaded (98 octane) mixed with 2-stroke engine oil (1:40) (☛ p. 17) (All 125/150 models)
		Super unleaded (95 octane) mixed with 2-stroke engine oil (1:60) (☛ p. 17) (250 SX)
Total fuel tank capacity, approx. (All XC models)	10 l (2.6 US gal)	Super unleaded (95 octane) mixed with 2-stroke engine oil (1:60) (☛ p. 17)
Engine oil, 2-stroke (☛ p. 17)		

- Close the filler cap. (☛ p. 13)

4.1 Chassis tightening torques

Spoke nipple, front wheel	M4.5	6 Nm (4.4 lbf ft)	–
Spoke nipple, rear wheel	M4.5	6 Nm (4.4 lbf ft)	–
Remaining nuts, chassis	M5	5 Nm (3.7 lbf ft)	–
Remaining screws, chassis	M5	5 Nm (3.7 lbf ft)	–
Screw, battery terminal (All XC models)	M5	2.5 Nm (1.84 lbf ft)	–
Screw, shock absorber adjusting ring	M5	5 Nm (3.7 lbf ft)	–
Screws on the main silencer	M5	7 Nm (5.2 lbf ft)	–
Nut, cable on starter motor (All XC models)	M6	4 Nm (3 lbf ft)	–
Remaining nuts, chassis	M6	10 Nm (7.4 lbf ft)	–
Remaining screws, chassis	M6	10 Nm (7.4 lbf ft)	–
Screw, absorbing element on frame	M6	6 Nm (4.4 lbf ft)	–
Screw, absorbing element on manifold	M6	6 Nm (4.4 lbf ft)	–
Screw, ball joint of push rod on foot brake cylinder	M6	10 Nm (7.4 lbf ft)	Loctite® 243™
Screw, chain sliding guard	M6	6 Nm (4.4 lbf ft)	Loctite® 243™
Screw, front brake disc	M6	14 Nm (10.3 lbf ft)	Loctite® 243™
Screw, rear brake disc	M6	14 Nm (10.3 lbf ft)	Loctite® 243™
Screw, throttle grip	M6	5 Nm (3.7 lbf ft)	–
Nut, foot brake lever stop	M8	20 Nm (14.8 lbf ft)	–
Nut, rear sprocket screw	M8	35 Nm (25.8 lbf ft)	Loctite® 2701™
Nut, rim lock	M8	12 Nm (8.9 lbf ft)	–
Remaining nuts, chassis	M8	25 Nm (18.4 lbf ft)	–
Remaining screws, chassis	M8	25 Nm (18.4 lbf ft)	–
Screw, bottom triple clamp	M8	12 Nm (8.9 lbf ft)	–
Screw, chain sliding piece	M8	15 Nm (11.1 lbf ft)	–
Screw, engine brace (All 125/150 models)	M8	25 Nm (18.4 lbf ft)	Loctite® 2701™
Screw, engine brace (All 250/300 models)	M8	33 Nm (24.3 lbf ft)	Loctite® 2701™
Screw, fork stub	M8	15 Nm (11.1 lbf ft)	–
Screw, front brake caliper	M8	25 Nm (18.4 lbf ft)	Loctite® 243™
Screw, handlebar clamp	M8	20 Nm (14.8 lbf ft)	–
Screw, side stand attachment (All XC models)	M8	35 Nm (25.8 lbf ft)	Loctite® 2701™
Screw, subframe	M8	35 Nm (25.8 lbf ft)	Loctite® 2701™
Screw, top steering stem (All SX models)	M8	20 Nm (14.8 lbf ft)	Loctite® 243™
Screw, top steering stem (All XC models)	M8	17 Nm (12.5 lbf ft)	Loctite® 243™
Screw, top triple clamp	M8	17 Nm (12.5 lbf ft)	–
Engine bracket screw	M10	60 Nm (44.3 lbf ft)	–
Remaining nuts, chassis	M10	45 Nm (33.2 lbf ft)	–
Remaining screws, chassis	M10	45 Nm (33.2 lbf ft)	–
Screw, bottom shock absorber	M10	60 Nm (44.3 lbf ft)	Loctite® 2701™
Screw, handlebar support	M10	40 Nm (29.5 lbf ft)	Loctite® 243™
Screw, top shock absorber	M10	60 Nm (44.3 lbf ft)	Loctite® 2701™
Nut, seat fixing (All 250/300 models)	M12x1	20 Nm (14.8 lbf ft)	–
Nut, frame on linkage lever	M14x1.5	80 Nm (59 lbf ft)	–
Nut, linkage lever on swingarm	M14x1.5	80 Nm (59 lbf ft)	–
Nut, linkage lever to angle lever	M14x1.5	80 Nm (59 lbf ft)	–
Nut, swingarm pivot	M16x1.5	100 Nm (73.8 lbf ft)	–

4 TECHNICAL DATA

Screw, front wheel spindle	M20x1.5	35 Nm (25.8 lbf ft)	–
Screw, top steering head	M20x1.5	12 Nm (8.9 lbf ft)	–
Screw-in nozzles, cooling system	M20x1.5	12 Nm (8.9 lbf ft)	Loctite® 243™
Nut, rear wheel spindle	M25x1.5	80 Nm (59 lbf ft)	–

Engine oil, 2-stroke

Standard/classification

- JASO FD (☛ p. 19)

Guideline

- Only use high grade 2-stroke engine oil of a reputable brand.

Fully synthetic

Recommended supplier

Motorex®

- Cross Power 2T

Super unleaded (ROZ 98 / RON 98 / PON 94)

Standard/classification

- DIN EN 228 (ROZ 98 / RON 98 / PON 94)

Super unleaded (ROZ 95/RON 95/PON 91)

Standard/classification

- DIN EN 228 (ROZ 95/RON 95/PON 91)

Guideline

- Only use unleaded super fuel that matches or is equivalent to the specified fuel grade.
- Fuel with an ethanol content of up to 10 % (E10 fuel) is safe to use.



Info

Do **not** use fuel containing methanol (e. g. M15, M85, M100) or more than 10 % ethanol (e. g. E15, E25, E85, E100).

Super unleaded (95 octane) mixed with 2-stroke engine oil (1:60)

Standard/classification

- DIN EN 228
- JASO FD (☛ p. 19) (1:60)

Mixture ratio

1:60	Engine oil, 2-stroke (☛ p. 17) Super unleaded (ROZ 95/RON 95/PON 91) (☛ p. 17)
------	---

Recommended supplier

Motorex®

- Cross Power 2T

Super unleaded (98 octane) mixed with 2-stroke engine oil (1:40)

Standard/classification

- DIN EN 228
- JASO FD (☛ p. 19) (1:40)

Mixture ratio

1:40	Engine oil, 2-stroke (☛ p. 17) Super unleaded (ROZ 98 / RON 98 / PON 94) (☛ p. 17)
------	---

Recommended supplier

Motorex®

- Cross Power 2T

Long-life grease

Recommended supplier

Motorex®

– Bike Grease 2000

JASO FD

JASO FD is a classification for a 2-stroke engine oil that was specifically developed for the extreme demands of racing. Thanks to first rate synthetic esters and specially designed additives, superb combustion is achieved even under extreme operating conditions.

READY TO RACE

>> www.ktm.com



3213435en

11/2015



KTM

KTM Sportmotorcycle GmbH
5230 Mattighofen/Austria
<http://www.ktm.com>



KTM Group Partner



REG. NO. 12 100 6661

Photo: Mitterbauer/KTM