

## 1290 Super Duke GT

Art. no. 3213552en



**KTM**



# DEAR KTM CUSTOMER

Congratulations on your decision to purchase a KTM motorcycle. You are now the owner of a state-of-the-art sports motorcycle that will give you enormous pleasure if you service and maintain it properly.

We hope you enjoy your new vehicle!

Enter the serial numbers of your vehicle below.

Chassis number (📖 p. 22)	Dealer's stamp
Engine number (📖 p. 23)	
Key number (📖 p. 23)	

The Owner's Manual contained the latest information for this model series at the time of going to print. However, minor differences due to developments in design cannot be ruled out completely.

All specifications are non-binding. KTM Sportmotorcycle GmbH specifically reserves the right to modify or delete technical specifications, prices, colors, forms, materials, services, designs, equipment, etc., without prior notice and without specifying reasons, to adapt these to local conditions, as well as to stop production of a particular model without prior notice. KTM accepts no liability for delivery options, deviations from illustrations and descriptions, misprints, and other errors. The models portrayed partly contain special equipment that does not belong to the regular scope of supply.

© 2016 KTM Sportmotorcycle GmbH, Mattighofen Austria  
All rights reserved



3213552en

09/2016

# DEAR KTM CUSTOMER

Reproduction, even in part, as well as copying of all kinds, is permitted only with the express written permission of the copyright owner.



ISO 9001(12 100 6061)

According to the international quality management standard ISO 9001, KTM uses quality assurance processes that lead to the maximum possible quality of the products.

Issued by: TÜV Management Service

REG.NO. 12 100 6061

KTM Sportmotorcycle GmbH  
5230 Mattighofen, Austria

This document is valid for the following models:

1290 Super Duke GT EU (F9903QF, F9903QE)



1290 Super Duke GT JP (F9986QE)

1290 Super Duke GT CN (F9987QE)

# TABLE OF CONTENTS

1	MEANS OF REPRESENTATION .....	8	5.5	Fork part number .....	24
	1.1 Symbols used .....	8	5.6	Shock absorber article number .....	24
	1.2 Formats used.....	9	5.7	Steering damper article number .....	25
2	SAFETY ADVICE.....	10	6	CONTROLS.....	26
	2.1 Use definition – intended use.....	10	6.1	Clutch lever.....	26
	2.2 Misuse.....	10	6.2	Hand brake lever.....	26
	2.3 Safety advice.....	10	6.3	Throttle grip .....	27
	2.4 Degrees of risk and symbols .....	11	6.4	Switches on the left side of the handlebar .....	27
	2.5 Tampering warning.....	11	6.4.1	Combination switch, left side .....	27
	2.6 Safe operation .....	12	6.4.2	Light switch .....	28
	2.7 Protective clothing .....	13	6.4.3	Hazard warning flasher switch.....	28
	2.8 Work rules.....	13	6.4.4	Menu switch.....	29
	2.9 Environment.....	13	6.4.5	Turn signal switch.....	29
	2.10 Owner's Manual .....	14	6.4.6	Horn button .....	30
3	IMPORTANT NOTES.....	15	6.5	Switches on the right side of the handlebar .....	30
	3.1 Manufacturer and implied warranty.....	15	6.5.1	Combination switch, right .....	30
	3.2 Operating and auxiliary substances .....	15	6.5.2	Emergency OFF switch .....	31
	3.3 Spare parts, accessories .....	15	6.5.3	Switch for the cruise control system .....	32
	3.4 Service .....	16	6.5.4	Upper button of the cruise control system .....	33
	3.5 Figures .....	16	6.5.5	Lower button of the cruise control system.....	34
	3.6 Customer service.....	16	6.5.6	Electric starter button .....	35
4	VIEW OF VEHICLE .....	18	6.5.7	Locking the steering.....	35
	4.1 View of vehicle, front left (example) .....	18	6.5.8	Unlocking the steering .....	36
	4.2 View of vehicle, rear right (example) .....	20	6.5.9	Socket for electrical accessories.....	36
5	SERIAL NUMBERS .....	22	6.6	Ignition/steering lock.....	37
	5.1 Chassis number .....	22	6.7	Immobilizer .....	37
	5.2 Type label .....	22	6.8	Opening the filler cap.....	38
	5.3 Key number.....	23	6.9	Closing the filler cap .....	40
	5.4 Engine number .....	23	6.10	Seat lock.....	41









# TABLE OF CONTENTS

6.11	Tool set.....	41	7.10.13	"Drive Mod".....	58
6.12	Grab handle .....	42	7.10.14	menu overview.....	60
6.13	Passenger footrests .....	42	7.10.15	"Language".....	62
6.14	Shift lever .....	43	7.10.16	"Distance" .....	62
6.15	Foot brake lever .....	44	7.10.17	"Temp" .....	63
6.16	Side stand.....	44	7.10.18	"Pressure" .....	63
7	COMBINATION INSTRUMENT .....	45	7.10.19	"Fuel Cons" .....	64
7.1	Overview .....	45	7.10.20	"Clock/Date" .....	64
7.2	activation and test .....	45	7.10.21	"Shift Light" .....	65
7.3	Matrix display.....	46	7.10.22	"Heat Grip".....	65
7.4	Segment display .....	46	7.10.23	"cLightTest".....	66
7.5	Fuel level display .....	47	7.10.24	"DRL" .....	66
7.6	Indicator lamps.....	47	7.10.25	"Quickshifter" .....	67
7.7	Message on the matrix display.....	48	8	ERGONOMICS .....	68
7.8	Shift warning light .....	50	8.1	Handlebar position .....	68
7.9	Service display .....	51	8.2	Adjusting the handlebar position  .....	68
7.10	Matrix display menu .....	51	8.3	Adjusting the windshield .....	70
7.10.1	"Favorites".....	51	8.4	Adjusting the basic position of the clutch lever ....	72
7.10.2	"Trip 1" .....	52	8.5	Adjusting the basic position of the hand brake lever .....	72
7.10.3	"Trip 2".....	52	8.6	Adjusting the basic position of the foot brake lever  .....	73
7.10.4	"General Info".....	53	8.7	Setting the step plate of the foot brake lever.....	74
7.10.5	"TPMS" .....	53	8.8	Checking the basic position of the shift lever .....	74
7.10.6	"Set Favorites" .....	54	8.9	Adjusting the basic position of the shift lever  ....	75
7.10.7	"Settings".....	55	8.10	Setting the shift lever stub.....	76
7.10.8	"Warning".....	55	9	PREPARING FOR USE.....	77
7.10.9	"Heating" .....	56	9.1	Advice on first use .....	77
7.10.10	"MTC/ABS".....	56	9.2	Running in the engine .....	78
7.10.11	"Load".....	57			
7.10.12	"Damping".....	58			

# TABLE OF CONTENTS

9.3	Loading the vehicle .....	79	13.5	Removing the passenger seat .....	106
10	RIDING INSTRUCTIONS .....	81	13.6	Mounting the passenger seat .....	106
10.1	Checks and maintenance measures when preparing for use .....	81	13.7	Removing the front rider's seat .....	107
10.2	Starting .....	82	13.8	Mounting the front rider's seat .....	108
10.3	Starting off .....	83	13.9	Removing the windshield .....	108
10.4	Start off with HHC (Option: Hill-start assist) .....	83	13.10	Installing the windshield .....	109
10.5	Quickshifter .....	85	13.11	Removing the main silencer 🗑️ .....	109
10.6	Shifting, riding .....	85	13.12	Installing the main silencer 🗑️ .....	111
10.7	MSR (Option: Engine braking control) .....	90	13.13	Checking the chain for dirt .....	112
10.8	Applying the brakes .....	90	13.14	Cleaning the chain .....	112
10.9	Stopping, parking .....	92	13.15	Checking the chain tension .....	114
10.10	Transport .....	94	13.16	Adjusting the chain tension .....	115
10.11	Refueling .....	95	13.17	Checking the chain, rear sprocket, engine sprocket, and chain guide .....	116
11	SERVICE SCHEDULE .....	97	13.18	Checking/correcting the fluid level of the hydraulic clutch .....	120
11.1	Additional information .....	97	13.19	Removing the tank spoiler .....	122
11.2	Required work .....	97	13.20	Installing the tank spoiler .....	123
11.3	Recommended work .....	99	13.21	Removing the front fender .....	125
12	SUSPENSION SETTING .....	101	13.22	Installing the front fender 🗑️ .....	125
12.1	Fork/shock absorber .....	101	13.23	Cleaning the dust boots of the fork legs .....	126
12.2	"Load" .....	101	14	BRAKE SYSTEM .....	127
12.3	"Damping" .....	102	14.1	Antilock braking system (ABS) .....	127
13	SERVICE WORK ON THE CHASSIS .....	103	14.2	Checking the brake discs .....	129
13.1	Lifting the motorcycle with the rear lifting gear ...	103	14.3	Checking the front brake fluid level .....	130
13.2	Removing the rear of motorcycle from the lifting gear .....	103	14.4	Adding front brake fluid 🗑️ .....	131
13.3	Lifting the motorcycle with the front lifting gear .....	104	14.5	Checking the front brake linings .....	133
13.4	Taking the motorcycle from the front lifting gear .....	105	14.6	Checking the rear brake fluid level .....	134
			14.7	Adding rear brake fluid 🗑️ .....	135

# TABLE OF CONTENTS

14.8	Checking the brake linings of the rear brake .....	137	18	ENGINE TUNING .....	179
15	WHEELS, TIRES .....	138	18.1	"Drive Mod" .....	179
15.1	Removing the front wheel  .....	138	18.2	Motorcycle traction control (MTC) .....	179
15.2	Installing the front wheel  .....	140	19	SERVICE WORK ON THE ENGINE .....	181
15.3	Removing the rear wheel  .....	142	19.1	Checking the engine oil level .....	181
15.4	Installing the rear wheel  .....	144	19.2	Changing the engine oil and oil filter, cleaning the oil screens  .....	182
15.5	Checking the tire condition .....	145	19.3	Adding engine oil .....	187
15.6	Checking the tire air pressure .....	147	20	CLEANING, CARE .....	190
16	ELECTRICAL SYSTEM .....	149	20.1	Cleaning motorcycle .....	190
16.1	Daytime running light (DRL) .....	149	20.2	Checks and maintenance steps for winter operation .....	192
16.2	Cornering headlight .....	149	21	STORAGE .....	194
16.3	Removing the battery  .....	150	21.1	Storage .....	194
16.4	Installing the battery  .....	152	21.2	Preparing for use after storage .....	195
16.5	Recharging the battery  .....	154	22	TROUBLESHOOTING .....	196
16.6	Changing the main fuse .....	158	23	TECHNICAL DATA .....	198
16.7	Changing the fuses in the fuse box .....	159	23.1	Engine .....	198
16.8	Changing the headlight bulb .....	162	23.2	Engine tightening torques .....	199
16.9	Checking the setting of the lighting system .....	163	23.3	Capacities .....	202
16.10	Adjusting the headlight range .....	165	23.3.1	Engine oil .....	202
16.11	Adjusting the cornering light range .....	166	23.3.2	Coolant .....	203
16.12	Activating/deactivating the ignition key .....	169	23.3.3	Fuel .....	203
16.13	Diagnostics connector .....	173	23.4	Chassis .....	203
16.14	ACC1 and ACC2 front .....	173	23.5	Electrical system .....	204
16.15	ACC1 and ACC2 rear .....	174	23.6	Tires .....	205
17	COOLING SYSTEM .....	175	23.7	Fork .....	205
17.1	Checking the coolant level in the compensating tank .....	175	23.8	Shock absorber .....	206
17.2	Correcting the coolant level in the compensating tank .....	176	23.9	Chassis tightening torques .....	206



# TABLE OF CONTENTS

24	SUBSTANCES .....	212
25	AUXILIARY SUBSTANCES .....	215
26	STANDARDS .....	217
27	INDEX OF SPECIAL TERMS .....	218
28	LIST OF ABBREVIATIONS.....	219
29	LIST OF SYMBOLS.....	220
29.1	Red symbols.....	220
29.2	Yellow and orange symbols.....	220
29.3	Green and blue symbols.....	221
	INDEX .....	222

## 1.1 Symbols used

The meaning of specific symbols is described below.

---



Indicates an expected reaction (e.g. of a work step or a function).



Indicates an unexpected reaction (e.g. of a work step or a function).



All work marked with this symbol requires specialist knowledge and technical understanding. In the interest of your own safety, have these jobs performed by an authorized KTM workshop. There, your motorcycle will be optimally cared for by specially trained experts using the specialist tools required.



Indicates a page reference (more information is provided on the specified page).



Indicates information with more details or tips.



Indicates the result of a testing step.

---

# 1 MEANS OF REPRESENTATION

## 1.2 Formats used

The typographical formats used in this document are explained below.

---

<b>Specific name</b>	Identifies a proprietary name.
<b>Name®</b>	Identifies a protected name.
<b>Brand™</b>	Identifies a brand available on the open market.
<b><u>Underlined terms</u></b>	Refer to technical details of the vehicle or indicate technical terms that are explained in the glossary.

---

### 2.1 Use definition – intended use

KTM Street motorcycles are designed and constructed to meet the normal demands of regular road operation and also for use on race courses. They are not designed for offroad use.

---

 **Info**  
The motorcycle is only authorized for operation on public highways in the homologated version.

---

### 2.2 Misuse

The vehicle must only be used as intended.

Dangers can arise for people, property and the environment through use not as intended.

Any use of the vehicle beyond the intended and defined use constitutes misuse.

Misuse also includes the use of operating and auxiliary fluids which do not meet the required specification for the respective use.

### 2.3 Safety advice

A number of safety instructions need to be followed to operate the vehicle safely. Therefore, read this manual carefully. The safety instructions are highlighted in the text and are referred to at the relevant passages.

---

 **Info**  
The vehicle has various information and warning labels at prominent locations. Do not remove information/warning labels. If they are missing, you or others may not recognize dangers and may therefore be injured.

---

### 2.4 Degrees of risk and symbols

---



#### **Danger**

Indicates a danger that will immediately and invariably lead to fatal or serious permanent injury if the appropriate measures are not taken.



#### **Warning**

Indicates a danger that is likely to lead to fatal or serious injury if the appropriate measures are not taken.



#### **Caution**

Indicates a danger that may lead to minor injuries if the appropriate measures are not taken.

#### **Note**

Indicates a danger that will lead to considerable machine and material damage if the appropriate measures are not taken.



#### **Warning**

Indicates a danger that will lead to environmental damage if the appropriate measures are not taken.

---

### 2.5 Tampering warning

Tampering with the noise control system is prohibited. Federal law prohibits the following acts or the causing thereof:

- 1 The removal or rendering inoperative by any person other than for purposes of maintenance, repair, or replacement, of any device or element of design incorporated into any new vehicle for the purpose of noise control prior to its sale or delivery to the ultimate purchaser or while it is in use, or
- 2 the use of the vehicle after such device or element of design has been removed or rendered inoperative by any person.

Among those acts presumed to constitute tampering are the acts listed below:

- 1 Removal or puncturing of the main silencer, baffles, header pipes or any other components which conduct exhaust gases.
- 2 Removal or puncturing of parts of the intake system.
- 3 Lack of proper maintenance.
- 4 Replacing moving part of the vehicle, or parts of the exhaust or intake system, with parts other than those specified by the manufacturer.

### 2.6 Safe operation



#### **Danger**

**Danger of accidents** A rider who is not fit to ride poses a danger to him or herself and others.

- Do not operate the vehicle if you are not fit to ride due to alcohol, drugs or medication.
- Do not operate the vehicle if you are physically or mentally impaired.



#### **Danger**

**Danger of poisoning** Exhaust gases are toxic and inhaling them may result in unconsciousness and death.

- Always make sure there is sufficient ventilation when running the engine.
- Use an effective exhaust extraction system when starting or running the engine in an enclosed space.



#### **Warning**

**Danger of burns** Some vehicle components become very hot when the vehicle is operated.

- Do not touch any parts such as the exhaust system, radiator, engine, shock absorber, or brake system before the vehicle parts have cooled down.
- Let the vehicle parts cool down before you perform any work on the vehicle.

Only operate the vehicle when it is in perfect technical condition, in accordance with its intended use, and in a safe and environmentally compatible manner.

The vehicle should only be used by trained persons. An appropriate driver's license is needed to ride the vehicle on public roads.

Have malfunctions that impair safety promptly eliminated by an authorized KTM workshop.

Adhere to the information and warning labels on the vehicle.

### 2.7 Protective clothing



#### Warning

**Risk of injury** Missing or poor protective clothing presents an increased safety risk.

- Wear appropriate protective clothing such as helmet, boots, gloves as well as trousers and a jacket with protectors on all rides.
- Always wear protective clothing that is in good condition and meets the legal regulations.

In the interest of your own safety, KTM recommends that you only operate the vehicle while wearing protective clothing.

### 2.8 Work rules

Special tools are necessary for certain tasks. The tools are not contained in the vehicle but can be ordered under the number in parentheses. E.g.: bearing puller (15112017000)

During assembly, non-reusable parts (e.g. self-locking screws and nuts, seals and seal rings, O-rings, pins, lock washers) must be replaced by new parts.

In some instances, a thread locker (e.g. **Loctite**®) is required. The manufacturer instructions for use must be followed.

After disassembly, clean the parts that are to be reused and check them for damage and wear. Change damaged or worn parts.

After you complete the repair or service work, check the operating safety of the vehicle.

### 2.9 Environment

If you use your motorcycle responsibly, you can ensure that problems and conflicts do not occur. To protect the future of the motorcycle sport, make sure that you use your motorcycle legally, display environmental consciousness, and respect the rights of others.

When disposing of used oil, other operating and auxiliary fluids, and used components, comply with the laws and regulations of the respective country.

Because motorcycles are not subject to the EU regulations governing the disposal of used vehicles, there are no legal regulations that pertain to the disposal of an end-of-life motorcycle. Your authorized KTM dealer will be glad to advise you.

### 2.10 Owner's Manual

It is important that you read this Owner's Manual carefully and completely before making your first trip. The Owner's Manual contains useful information and many tips on how to operate, handle, and maintain your motorcycle. Only then will you find out how to customize the vehicle ideally for your own use and how you can protect yourself from injury.

Keep the Owner's Manual in an accessible place to enable you to refer to it as needed.

If you would like to know more about the vehicle or have questions on the material you read, please contact an authorized KTM dealer.

The Owner's Manual is an important component of the vehicle and must be handed over to the new owner if the vehicle is sold.



### 3.1 Manufacturer and implied warranty

The work specified in the service schedule may only be performed in an authorized KTM workshop and must be recorded in both the Service & Warranty Booklet and in **KTM Dealer.net**, otherwise any warranty coverage will become void. Damage or secondary damage caused by tampering with and/or conversions on the vehicle are not covered by the warranty.

Additional information on the manufacturer or implied warranty and the procedures involved can be found in the Service & Warranty Booklet.

### 3.2 Operating and auxiliary substances



#### Warning

**Environmental hazard** Improper handling of fuel is a danger to the environment.

- Do not allow fuel to enter the groundwater, the soil, or the sewage system.

Use operating and auxiliary substances (such as fuel and lubricants) as specified in the Owner's Manual.

### 3.3 Spare parts, accessories

For your own safety, only use spare parts and accessory products that are approved and/or recommended by KTM and have them installed by an authorized KTM workshop. KTM accepts no liability for other products and any resulting damage or loss.

Certain spare parts and accessory products are specified in parentheses in the descriptions. Your authorized KTM dealer will be glad to advise you.

The current **KTM PowerParts** for your vehicle can be found on the KTM website.

International KTM Website: <http://www.ktm.com>

### 3.4 Service

A prerequisite for perfect operation and prevention of premature wear is that the service, care, and tuning work on the engine and chassis is properly carried out as described in the Owner's Manual. Incorrect adjustment and tuning of the engine and chassis can lead to damage and breakage of components.

Use of the vehicle under difficult conditions, such in rain, high heat or with a heavy load, can lead to considerably more rapid wear of components such as the drive train, brake system, or suspension components. For this reason, it may be necessary to inspect or replace parts before the next scheduled service.

It is imperative that you adhere to the stipulated run-in times and service intervals. If you observe these exactly, you will ensure a much longer service life for your motorcycle.

### 3.5 Figures

The figures contained in the manual may depict special equipment.

In the interest of clarity, some components may be shown disassembled or may not be shown at all. It is not always necessary to disassemble the component to perform the activity in question. Please follow the instructions in the text.

### 3.6 Customer service

Your authorized KTM dealer will be happy to answer any questions you may have on your vehicle and KTM.

A list of authorized KTM dealers can be found on the KTM website.

International KTM Website: <http://www.ktm.com>



# 4 VIEW OF VEHICLE

## 4.1 View of vehicle, front left (example)

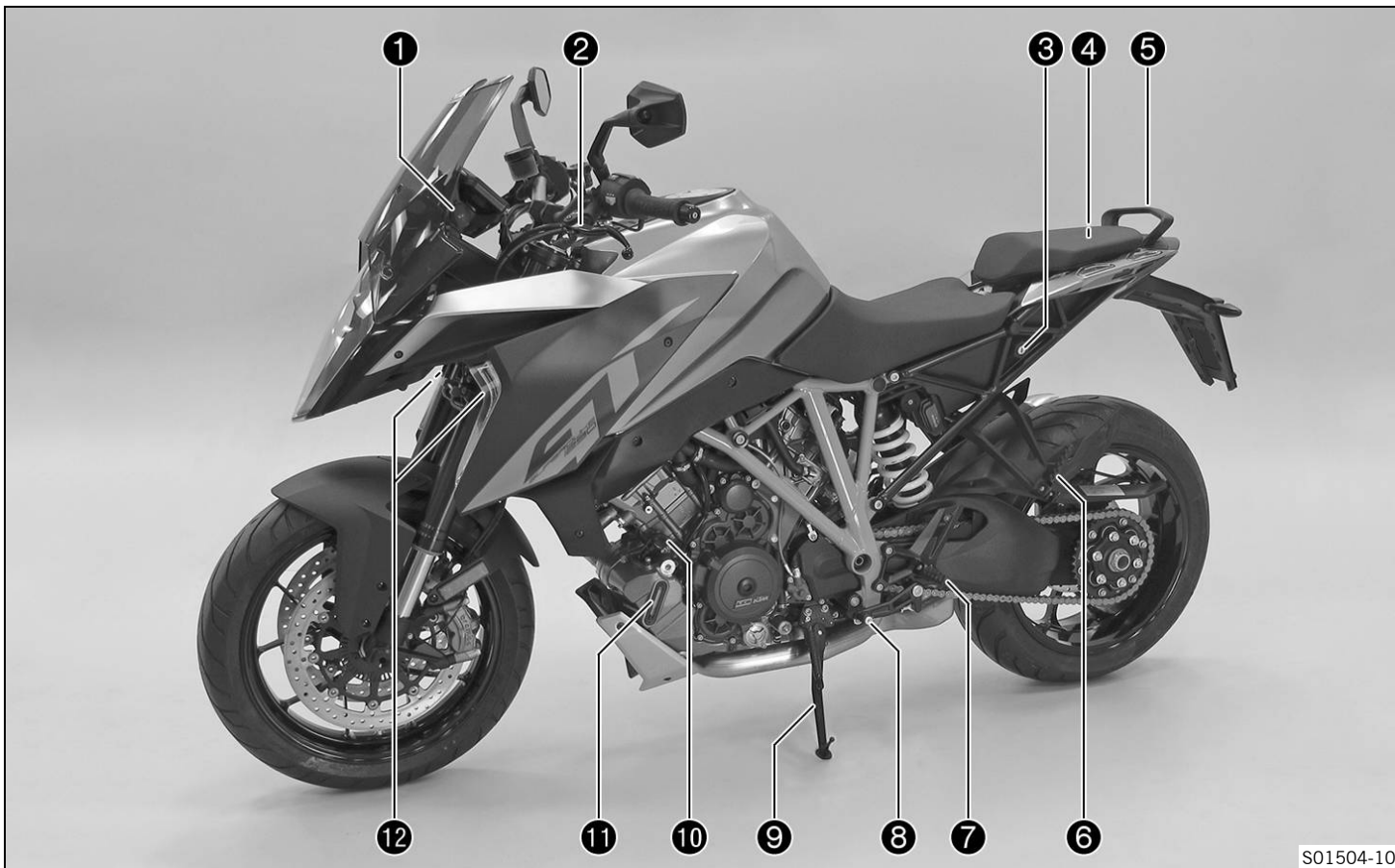

# 4 VIEW OF VEHICLE

1	Socket for electrical accessories (📖 p. 36)
2	Clutch lever (📖 p. 26)
3	Seat lock (📖 p. 41)
4	Tool set (📖 p. 41)
5	Grab handle (📖 p. 42)
6	Passenger footrests (📖 p. 42)
7	Rider footrests
8	Shift lever (📖 p. 43)
9	Side stand (📖 p. 44)
10	Engine oil filler neck
11	Level viewer, engine oil
12	Cornering headlight (📖 p. 149)

# 4 VIEW OF VEHICLE

## 4.2 View of vehicle, rear right (example)

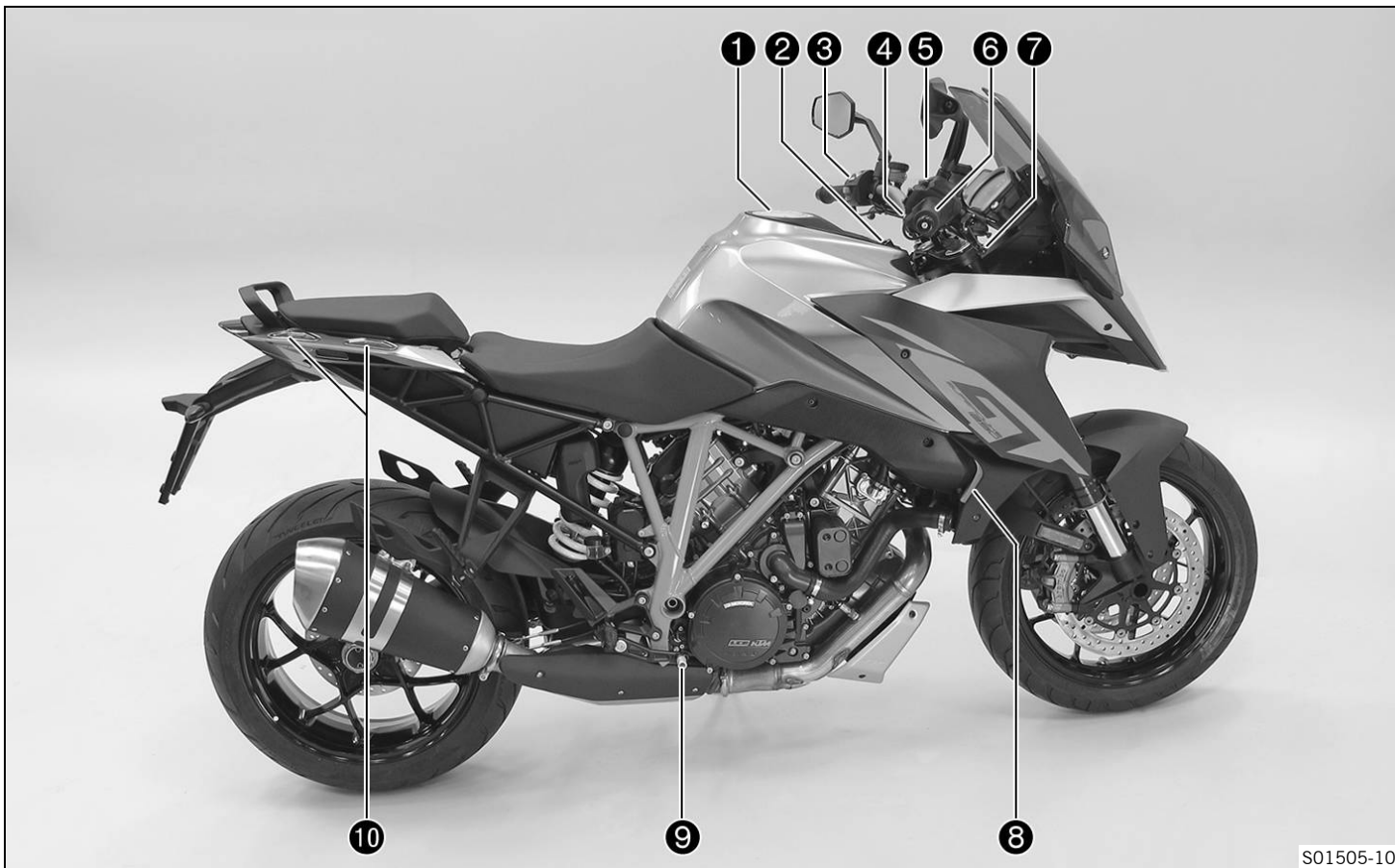

# 4 VIEW OF VEHICLE

---

1	Filler cap
2	Ignition/steering lock (📖 p. 37)
3	Combination switch, left side (📖 p. 27)
4	Electric starter button (📖 p. 35)
5	Emergency OFF switch (📖 p. 31)
6	Throttle grip (📖 p. 27)
7	Hand brake lever (📖 p. 26)
8	Cooling system compensating tank
9	Foot brake lever (📖 p. 44)
10	Suitcase bracket

---

## 5.1 Chassis number

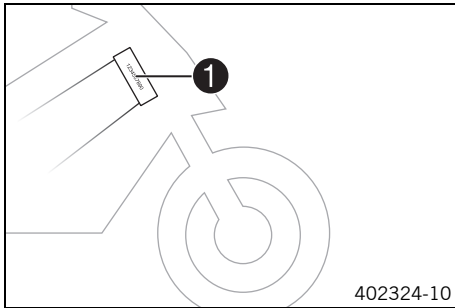

The chassis number **1** is stamped on the right side of the steering head. The chassis number is also shown on the type label.

## 5.2 Type label

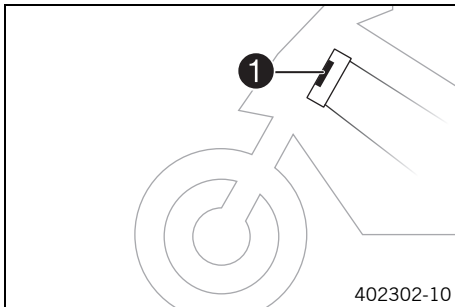

The type label **1** is located on the steering head.



## 5.3 Key number

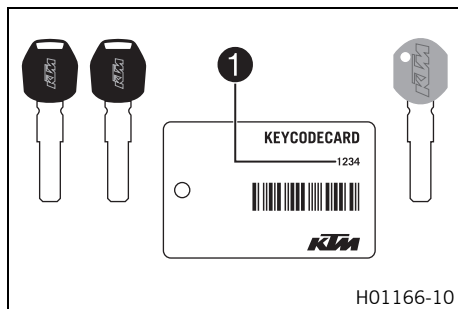

Key number **Code number 1** can be found on the **KEYCODECARD**.



### Info

You need the key number to order a spare key. Keep the **KEYCODECARD** in a safe place.

With the orange programming key, you can activate or deactivate the black ignition key. Keep the orange programming key in a safe location; it may only be used for learning and programming functions.

## 5.4 Engine number

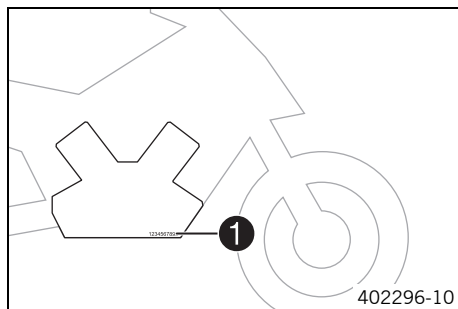

The engine number **1** is stamped on the right side of the engine.

## 5.5 Fork part number

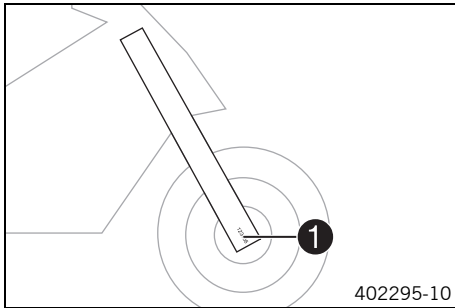

The fork part number ❶ is stamped on the inside of the axle clamp.

## 5.6 Shock absorber article number

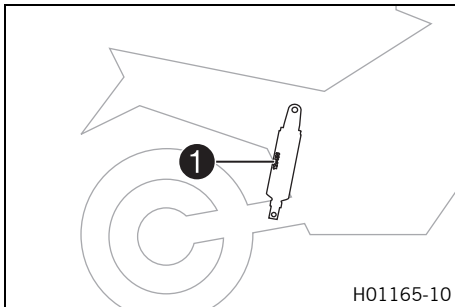

The shock absorber article number ❶ is printed on a sticker on the shock absorber case under the spring.

# 5 SERIAL NUMBERS

## 5.7 Steering damper article number

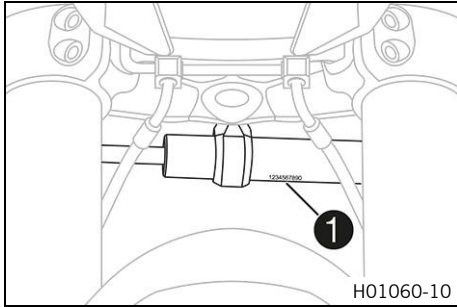

Steering damper item number ❶ is embossed on the underside of the steering damper.

## 6.1 Clutch lever



Clutch lever **1** is fitted on the handlebar on the left.  
The clutch is activated hydraulically and adjusts itself automatically.

## 6.2 Hand brake lever

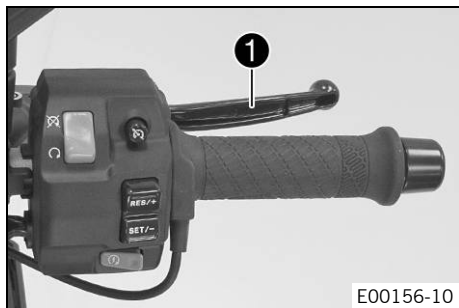

The hand brake lever **1** is fitted on the right side of the handlebar.  
The front brake is engaged using the hand brake lever.

## 6.3 Throttle grip

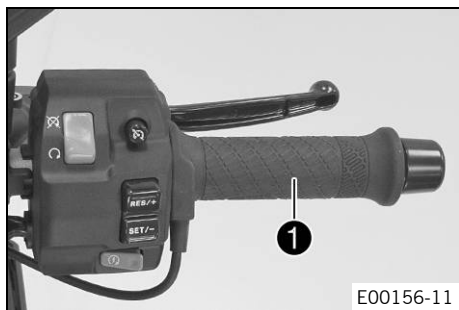

The throttle grip **1** is fitted on the right side of the handlebar.

## 6.4 Switches on the left side of the handlebar

### 6.4.1 Combination switch, left side

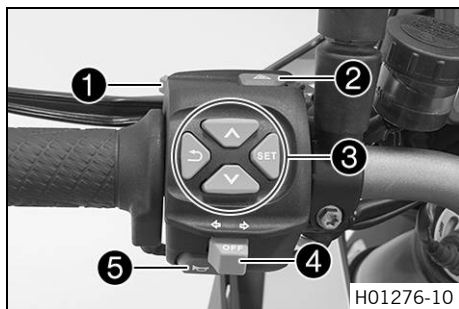

The left combination switch is fitted on the left side of the handlebar.

#### Overview of the left combination switch

- |   |   |
|---|---|
| 1 | Light switch (📖 p. 28)                  |
| 2 | Hazard warning flasher switch (📖 p. 28) |
| 3 | Menu switch (📖 p. 29)                   |
| 4 | Turn signal switch (📖 p. 29)            |
| 5 | Horn button (📖 p. 30)                   |

## 6.4.2 Light switch

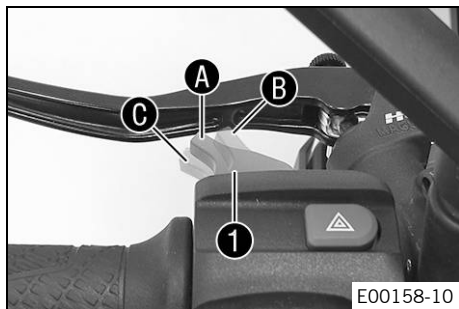

The light switch **1** is fitted on the combination switch on the left.

### Possible states

	Low beam on – Light switch in position <b>A</b> . In this position, the low beam and tail light are switched on.
	High beam on – Light switch in position <b>B</b> . In this position, the high beam and tail light are switched on.
	Headlight flasher – Push the light switch into position <b>C</b> .

## 6.4.3 Hazard warning flasher switch

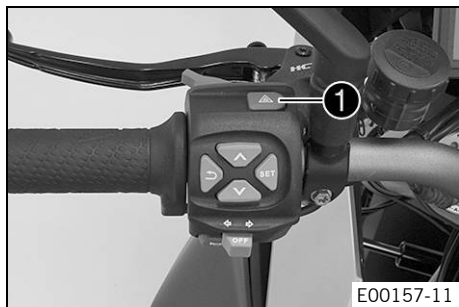

The hazard warning flasher switch **1** is fitted on the combination switch on the left. The hazard warning flasher is used to indicate emergency situations.

### Info

The hazard warning flasher can be activated or deactivated while the ignition is switched on or up to 60 seconds after the ignition is switched off. Only keep the hazard warning flasher activated as long as necessary as it depletes the battery.

### Possible states

	Hazard warning flasher on – All four turn signals and the green turn signal indicator lights in the combination instrument flash.
--	---

## 6.4.4 Menu switch

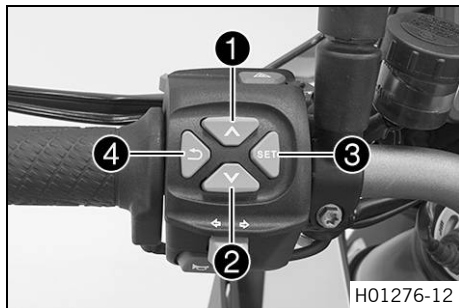

The menu switch is fitted in the middle of the left combination switch. The menu buttons are used to control the matrix display on the combination instrument.

Button **1** is the **UP** button.

Button **2** is the **DOWN** button.

Button **3** is the **SET** button.



Button **4** is the **BACK** button.

## 6.4.5 Turn signal switch



Turn signal switch **1** is fitted on the combination switch on the left.

### Possible states

<b>OFF</b>	Turn signal off – Push the turn signal switch toward the switch housing.
	Left turn signal, on – Turn signal switch pressed to the left. The turn signal switch returns automatically to the central position after use.
	Right turn signal, on – Turn signal switch pressed to the right. The turn signal switch returns automatically to the central position after use.

To switch off the turn signal, press the turn signal switch towards the switch case.



## Info

An automatic turn signal switch-off function (**ATIR**) is available as a software feature. The **ATIR** function uses a time and distance counter.

If the turn signal has been on for at least 10 seconds and 150 meters of riding distance, the turn signal is switched off.

If the vehicle is stationary, both counters are stopped.



If the turn signal switch is reactivated, both counters are reset.

## 6.4.6 Horn button



The horn button ① is fitted on the combination switch on the left.

### Possible states

- Horn button  in basic position.
- Horn button  pressed – The horn is operated in this position.

## 6.5 Switches on the right side of the handlebar

### 6.5.1 Combination switch, right

The right combination switch is fitted on the right side of the handlebar.



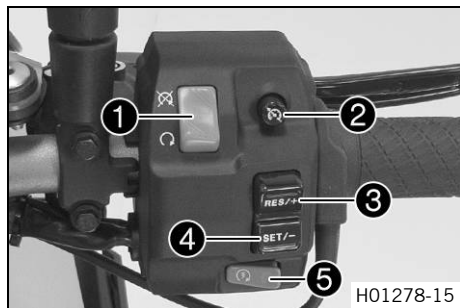

H01278-15

### Overview of the right combination switch

- |   |   |
|---|---|
| 1 | Emergency OFF switch (📖 p. 31)                      |
| 2 | Switch for the cruise control system (📖 p. 32)      |
| 3 | Upper button of the cruise control system (📖 p. 33) |
| 4 | Lower button of the cruise control system (📖 p. 34) |
| 5 | Electric starter button (📖 p. 35)                   |

### 6.5.2 Emergency OFF switch



H01278-10

The emergency OFF switch **1** is fitted on the right side of the handlebar.

#### Possible states

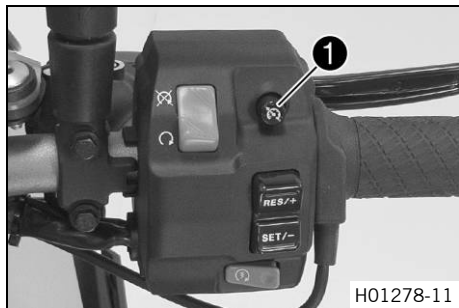

	Emergency OFF switch off – In this position, the ignition circuit is interrupted, a running engine stops, and a non-running engine cannot be started. A message appears on the matrix display.
	Emergency OFF switch on – This position is required for operation; the ignition circuit is closed.

## 6.5.3 Switch for the cruise control system



Switch **1** for the cruise control system is fitted on the right of the combination switch.

### Possible states

- Cruise control system switch  in the home position. – In this position, the cruise control system function is switched off.
- Cruise control system switch  in the pressed position. – In this position, the cruise control system function is switched on. The cruise control system indicator lamp  lights up in the combination instrument.

### Info

After activation of the cruise control system function, the throttle grip can be turned back to the home position. The selected speed will be maintained.

To turn off the cruise control system function press the cruise control system switch  again.

In addition, the cruise control system function is immediately deactivated when one of the following events occurs:

- Operating the hand brake lever
- Operating the foot brake lever
- Operating the clutch lever
- Shifting gears
- Turning the throttle grip beyond the home position
- Control of the motorcycle traction control (**MTC**)
- Also functions with deactivated motorcycle traction control (**MTC**) – if the front wheel speed does not match the engine speed (slip at the rear wheel of lifting front wheel)

- A fault occurring, which impairs the cruise control system function



### Warning

**Danger of accidents** The cruise control system function is not suitable for all driving situations.

The selected target speed will not be reached, if the engine power is not sufficient for a gradient.

The selected target speed will be exceeded if the engine braking effect is not sufficient on a decline.

- Do not use the cruise control systems function on winding roads.
- Do not use the cruise control systems on slippery road surfaces (e.g. rain, ice or snow) or unpaved surfaces (e.g. sand, stones or gravel).
- Do not use the cruise control systems function if the traffic does not permit a constant speed.

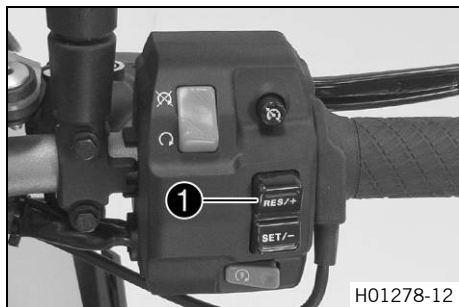

The cruise control system function cannot be activated during rapid acceleration.  
 The cruise control system function can only be activated in 4th, 5th and 6th gear.  
 The control range is from 40 to 200 km/h or from 25 to 125 mph.

## 6.5.4 Upper button of the cruise control system



Upper button ❶ of the cruise control system is fitted on the right side of the combination switch.

### Possible states

- Upper button of the cruise control system  in the home position.
- Upper button of the cruise control system  is pressed. – The last saved speed is reached and maintained. Every further short touch increases the target speed by 1 km/h or 1 mph.
- Upper button of the cruise control system  is held in the pressed position. – The target speed increases in increments of 5 km/h or 5 mph.

---

**i** **Info**

The target speed is shown on the segment display of the combination instrument. After activation of the cruise control system function the throttle grip can be turned back to the home position.

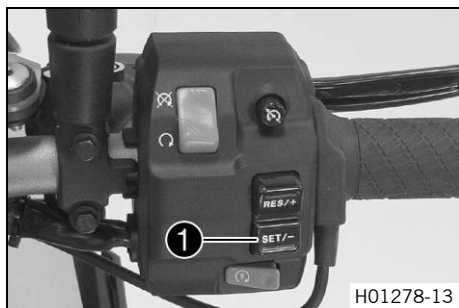

---

## 6.5.5 Lower button of the cruise control system



Lower button ❶ of the cruise control system is fitted on the right side of the combination switch.

**Possible states**

- Lower button of the cruise control system  in the home position.
- Lower button of the cruise control system  is pressed briefly. – The cruise control system function is activated and the current speed is maintained. Every further short touch decreases the target speed by 1 km/h or 1 mph.
- Lower button of the cruise control system  is held in the pressed position. – The target speed decreases in increments of 5 km/h or 5 mph.

---

**i** **Info**

The target speed is shown on the segment display of the combination instrument. After activation of the cruise control system function the throttle grip can be turned back to the home position.

---

## 6.5.6 Electric starter button



The electric starter button ❶ is fitted on the right side of the handlebar.

### Possible states

- Electric starter button ❸ in basic position.
- Electric starter button ❸ is pressed – In this position, the electric starter is actuated.

## 6.5.7 Locking the steering

### Note

**Danger of damage** The parked vehicle can roll away or fall over.

- Park the vehicle on a firm and level surface.



- Park the vehicle.
- Turn the handlebar all the way to the left.
- Insert the key into the ignition/handlebar lock, press in, and turn to the left. Remove the key.
- ✓ Steering is no longer possible.

## 6.5.8 Unlocking the steering



- Insert the key into the ignition/handlebar lock, press in, and turn to the right. Remove the key.
  - ✓ The handlebar can now be moved again.

## 6.5.9 Socket for electrical accessories

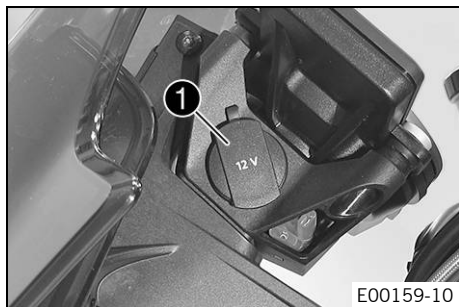

Socket ❶ for electrical accessories is mounted on the left side of the instrument support. It is connected to the permanent positive and is fuse-protected.

Socket for electrical accessories	
Voltage	12 V
Maximum current consumption	10 A

## 6.6 Ignition/steering lock

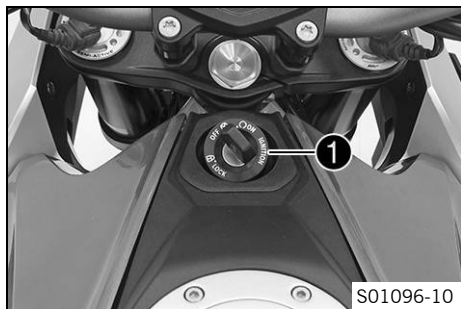

The ignition/steering lock ❶ is located in front of the upper triple clamp.



### Info

The ignition may only be switched on using a black ignition key. With the orange programming key, you can activate or deactivate the black ignition key.

### Possible states

	<p>Ignition off <b>OFF</b> – In this position, the ignition circuit is interrupted, a running engine stops, and a non-running engine will not start. The black ignition key can be removed.</p>
	<p>Ignition on <b>ON</b> – In this position, the ignition circuit is closed and the engine can be started.</p>
	<p>Steering locked – In this position, the ignition circuit is interrupted and the steering locked. The black ignition key can be removed.</p>

## 6.7 Immobilizer

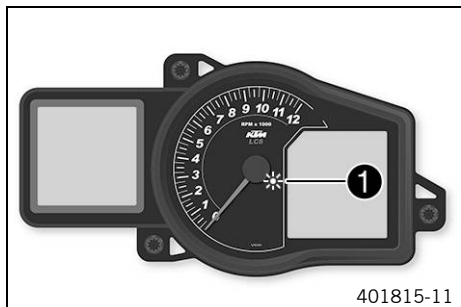

The electronic immobilizer secures the vehicle against unauthorized use.

The immobilizer is activated automatically and the engine electronics are locked when the ignition key is withdrawn.

The immobilizer indicator lamp ❶ can indicate errors by flashing.

If the optional alarm system is installed, the immobilizer indicator lamp ❶ flashes when the alarm system is switched on.



### Info

The ignition key contains electronic components. Never attach multiple ignition keys to a single key ring; this may cause mutual interference.

A lost black ignition key must be deactivated to prevent unauthorized persons from operating the vehicle.

The black ignition keys are activated when delivered.

Another two spare ignition keys (key number on the **KEYCODECARD**) can be ordered from an authorized KTM workshop; they need to be activated for use.

## 6.8 Opening the filler cap



### Danger

**Fire hazard** Fuel is highly flammable.

The fuel in the fuel tank expands when warm and can escape if overfilled.

- Do not refuel the vehicle in the vicinity of open flames or lit cigarettes.
- Switch off the engine for refueling.
- Make sure that no fuel is spilled; particularly not on hot parts of the vehicle.
- If any fuel is spilled, wipe it off immediately.
- Observe the specifications for refueling.



### Warning

**Danger of poisoning** Fuel is poisonous and a health hazard.

- Avoid skin, eye and clothing contact with fuel.
- Immediately consult a doctor if you swallow fuel.
- Do not inhale fuel vapors.
- In case of skin contact, rinse the affected area with plenty of water.
- Rinse the eyes thoroughly with water, and consult a doctor in case of fuel contact with the eyes.
- Change your clothing in case of fuel spills on them.
- Keep fuels correctly in a suitable canister, and out of the reach of children.





## Warning

**Environmental hazard** Improper handling of fuel is a danger to the environment.

- Do not allow fuel to enter the groundwater, the soil, or the sewage system.

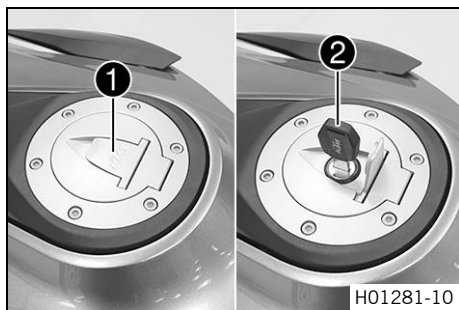

- Lift cover **1** of the filler cap and insert ignition key **2** in the fuel tank lock.

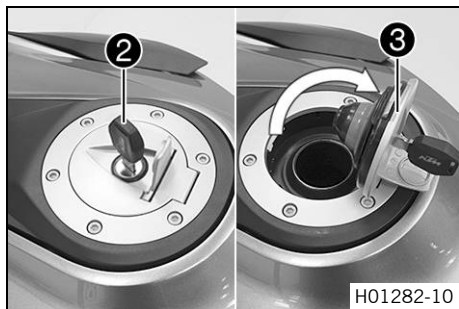

- Note**
- Danger of damage** Ignition key breakage.
- To take pressure off of the ignition key, push down on the filler cap. Damaged ignition keys must be replaced.
- 
- Turn ignition key **2** clockwise.
  - Fold open filler cap **3**.

## 6.9 Closing the filler cap

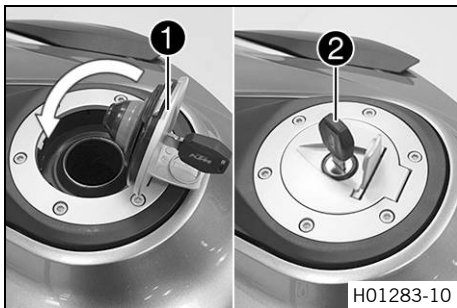

- Fold down filler cap ①.
- Turn ignition key ② clockwise.

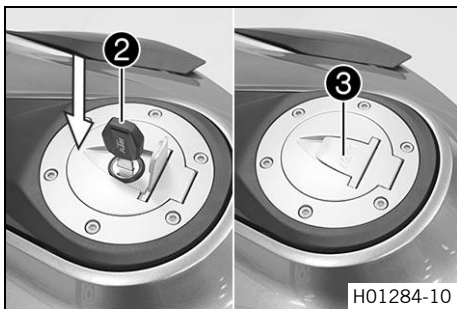

- Press down the filler cap and turn back ignition key ② until the fuel tank lock locks.



### Warning

**Fire hazard** Fuel is highly flammable, poisonous and harmful to your health.

- After closing the filler cap, ensure that it is locked properly. Change clothing that has been contaminated with fuel. Immediately clean contaminated areas on the skin with soap and water.
- 
- Remove ignition key ② and close cover ③.

## 6.10 Seat lock

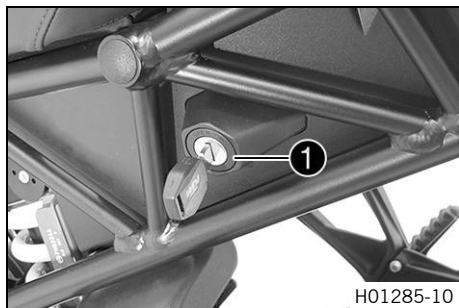

The seat lock **1** is located on the left side of the vehicle. It can be unlocked using the ignition key.

## 6.11 Tool set

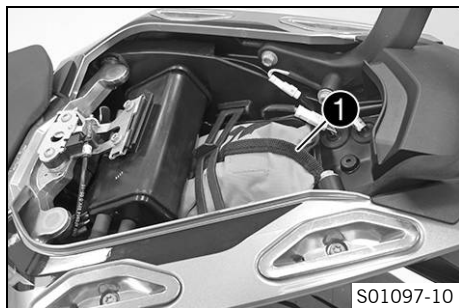

The storage compartment under the passenger seat contains tool set **1**.

## 6.12 Grab handle

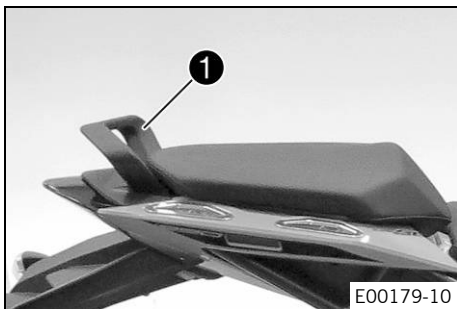

The passenger can hold onto the grab handle ❶ during the trip.

## 6.13 Passenger footrests

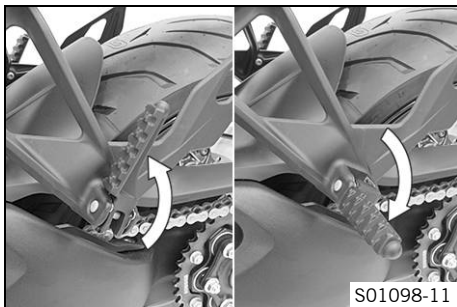

The passenger footrests can be folded up and down.

### Possible states

- Passenger footrests folded up – For operation without a passenger.
- Passenger footrests folded down – For operation with a passenger.

## 6.14 Shift lever

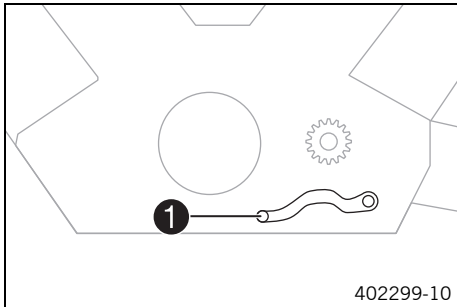

The shift lever **1** is fitted on the left side of the engine.

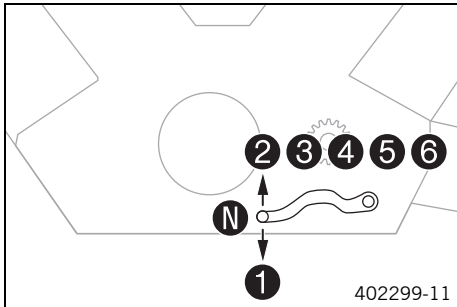

The gear positions can be seen in the figure.  
The idle position is between the first and second gears.

## 6.15 Foot brake lever

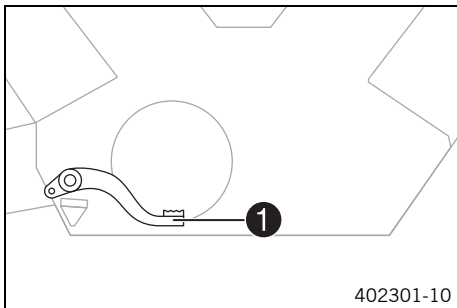

Foot brake lever ❶ is located in front of the right footrest. The rear brake is engaged with the foot brake lever.

## 6.16 Side stand

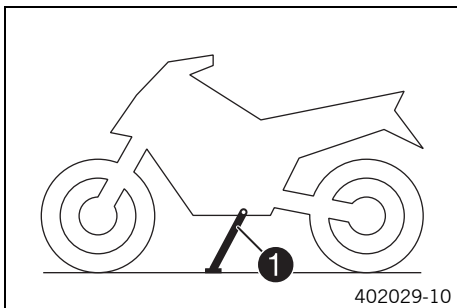

The side stand ❶ is located on the left side of the vehicle. The side stand is used for parking the motorcycle.



### Info

The side stand must be folded up during motorcycle use. The side stand is coupled with the safety starting system; see the instructions in the "Stopping, parking" chapter.

### Possible states

- Side stand folded out – The vehicle can be supported on the side stand. The safety starting system is active.
- Side stand folded in – This position is mandatory when riding the motorcycle. The safety starting system is inactive.

## 7.1 Overview

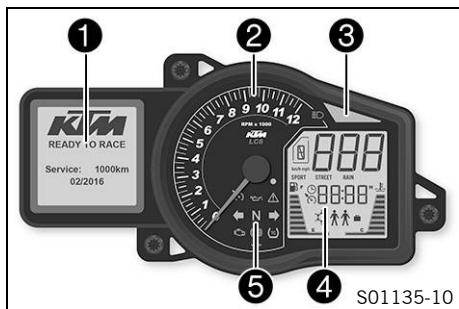

- 1 Matrix display (📖 p. 46)
- 2 Tachometer
- 3 Shift warning light (📖 p. 50)
- 4 Segment display
- 5 Indicator lamps (📖 p. 47)

## 7.2 activation and test

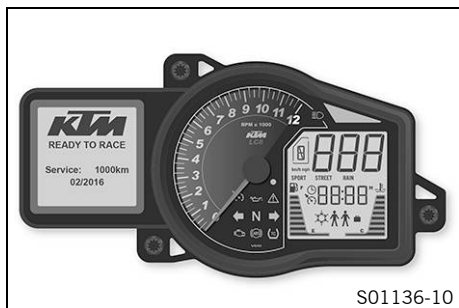

### Activation

The combination instrument is activated when the ignition is switched on.

### Info

The brightness of the displays is controlled by a brightness sensor in the combination instrument.

### Test

The segment display, the indicator lamps, and the tachometer are briefly activated for a function test.

The welcome text and information on the next service (📖 p. 51) appear on the matrix display.

### Info

If the battery was removed, the time and date must be set.

## 7.3 Matrix display

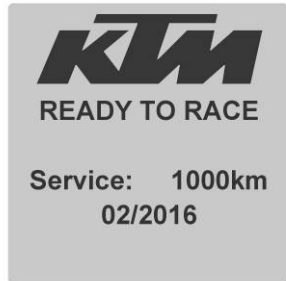

402656-01

The matrix display is controlled using the menu switch (📖 p. 29). After the ignition is switched on, the display shows when the next service (📖 p. 51) is due. If the General warning lamp  lights up among the indicator lamps (📖 p. 47), the corresponding message appears in the matrix display. The **Set** button is used to confirm receipt of the information and the message is cleared.

Messages appear	10 s
-----------------	------

## 7.4 Segment display

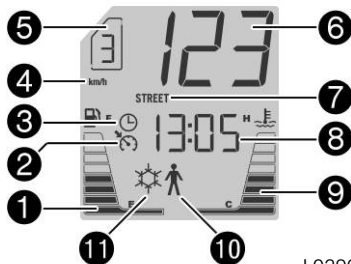

L02904-10

- 1 Fuel level display (📖 p. 47)
- 2 Cruise control system symbol
- 3 Time symbol
- 4 Unit for the speedometer
- 5 Gear display
- 6 Speed
- 7 **"Drive Mod"** (📖 p. 179)
- 8 Target speed of the cruise control system or time
- 9 Coolant temperature
- 10 **"Load"** (📖 p. 101)
- 11 Ice warning



## 7.5 Fuel level display

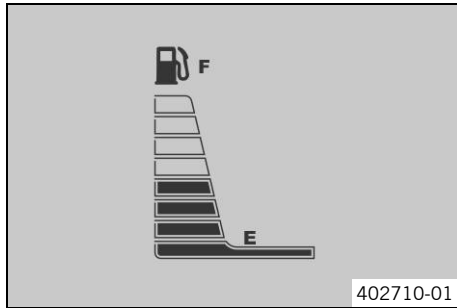

The fuel level display shows the filling level of the fuel tank.



### Info

The fuel level is displayed with a slight delay to prevent the display from constantly moving while riding.

The fuel level display is not updated while the side stand is folded out or the emergency off switch is switched off.

Once the side stand is folded in again, the fuel level display is next updated once 2 minutes have elapsed.







The fuel level display flashes if the combination instrument does not receive a signal from the fuel level sensor.

## 7.6 Indicator lamps



### Possible states





	The high beam indicator lamp lights up blue – The high beam is switched on.
	The immobilizer indicator lamp lights up/flashes red – Status or error message for immobilizer/alarm system.
	The oil pressure warning lamp lights up red – Engine oil pressure is too low.
	The general warning lamp lights up yellow – An operating safety (warning) message was detected. This is also shown on the matrix display.
	The left turn signal lamp flashes green simultaneously with the turn signal – The left turn signal is switched on.
	The idle indicator lamp lights up green – The transmission is in idle.

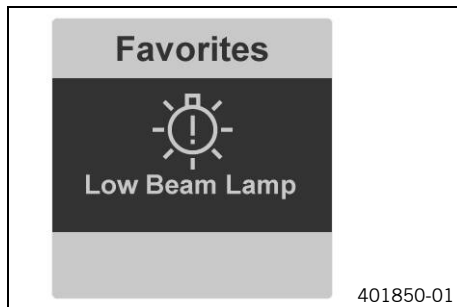









	The right turn signal lamp flashes with steady rhythmic flash – The right turn signal is switched on.
	The engine warning lamp lights up/flashes yellow – The engine control unit has detected a fault.
	The ABS lamp lights up/flashes yellow – The <u>ABS</u> is not active. The ABS lamp also lights up if an error is detected.
	The TC lamp lights up/flashes yellow – The motorcycle traction control is not enabled or is currently intervening. The TC lamp also lights up if an error is detected. In addition, the TC lamp flashes if the <b>HHC</b> (optional) is active.
	The cruise control system lamp lights up yellow – The cruise control system function is switched on, but the speed control is not active.
	The cruise control system lamp lights up green – The cruise control system function is switched on and the speed control is active.

## 7.7 Message on the matrix display



### Possible states

	Engine malfunction – The engine control unit has detected a fault. Visit an authorized KTM workshop.
	General message – General message on operating safety. Visit an authorized KTM workshop.
	ABS warning – The <u>ABS</u> function is not available. Visit an authorized KTM workshop.
	Motorcycle traction control – The motorcycle traction control is not available. Visit an authorized KTM workshop.

	Engine oil pressure – Engine oil pressure is too low. Switch off the engine immediately. Contact an authorized KTM workshop.
	Engine oil level – The engine oil level is too low. Check the engine oil level and correct it.
	Tire air pressure (optional) – The tire pressure is incorrect, or the system has failed. Check the tire air pressure.
	Lighting system – Lights up if an element of the lighting system has failed. Change the faulty light bulb, or visit an authorized KTM workshop.
	Coolant temperature – The coolant temperature is too high. Switch off the engine. Contact an authorized KTM workshop.
	Fuel reserve – The fuel supply is dwindling. Refuel at the next opportunity.
	Icy road symbol – The roads may be icy. Adjust your speed to the road conditions.
	Battery voltage – The battery voltage is too low. Recharge the battery with a suitable battery charger.
	Service – A service is due. Contact an authorized KTM workshop.
	Emergency OFF switch – The emergency OFF switch is off.

The messages are displayed in the **"Warning"** menu.

## 7.8 Shift warning light

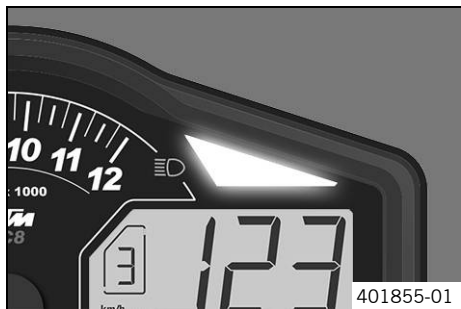

The shift warning light flashes or lights up when the transmission should be shifted. In the **"Shift Light"** menu, the engine speed for the shift warning light can be set. The shift warning light flashes at **"RPM1"** and lights up at **"RPM2"**.



### Info

In sixth-gear, the shift warning light is deactivated when the engine is warm after the first service.

The shift warning light can be turned on and off in the **"Settings"** menu.

Engine oil temperature	> 35 °C (> 95 °F)
<b>"ODO"</b>	> 1,000 km (> 620 mi)
<b>"RPM1"</b> shift warning light	flashes
<b>"RPM2"</b> shift warning light	lights up
Engine oil temperature	≤ 35 °C (≤ 95 °F)
<b>"ODO"</b>	< 1,000 km (< 620 mi)
The shift warning light always lights up at	6,500 rpm

## 7.9 Service display

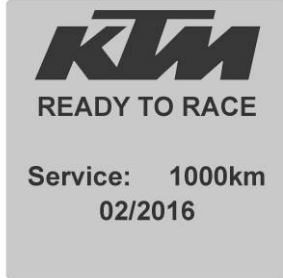

402656-01

After the ignition is switched on, the service display appears briefly. The service intervals depend on the distance traveled or the elapsed time. The event that occurs first applies. The exact service intervals can be found in the service schedule.

## 7.10 Matrix display menu

### 7.10.1 "Favorites"

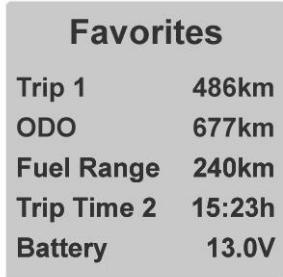

The image shows a rectangular matrix display menu. The title 'Favorites' is at the top. Below it, there are five rows of information:

Trip 1	486km
ODO	677km
Fuel Range	240km
Trip Time 2	15:23h
Battery	13.0V

L01440-10

- Press the **UP** or **DOWN** button until the "**Favorites**" menu appears on the matrix display. Pressing the **SET** button opens the menu.
- Press the **UP** or **DOWN** button to select the menu item and activate it with the **SET** button.
- Pressing the **BACK** button twice always opens the "**Favorites**" menu.

You can directly open five menus in the "**Favorites**" menu. The "**Favorites**" menu can be configured in the "**Set Favorites**" menu.

## 7.10.2 "Trip 1"

Trip 1	
Trip 1	973km
Ø Speed 1	89km/h
Ø Cons 1	10.3l
Trip Time 1	15:23h
Fuel Range	240km

401826-01

- Press the **UP** or **DOWN** button until the **"Trip 1"** menu appears on the matrix display. **"Trip 1"** shows the distance since the last reset, such as between two refueling stops. **"Trip 1"** runs continuously and counts the distance up to **9999**. **"Ø Speed 1"** indicates the average speed based on **"Trip 1"** and **"Trip Time 1"**. **"Ø Cons 1"** indicates the average fuel consumption based on **"Trip 1"** and **"Trip Time 1"**. **"Trip Time 1"** indicates the riding time based on **"Trip 1"** and starts running as soon as a speed signal comes in. **"Fuel Range"** indicates the possible range with the fuel reserve.

Press and hold the **SET** button for 3–5 seconds.

All entries in the **"Trip 1"** menu are cleared.

## 7.10.3 "Trip 2"

Trip 2	
Trip 2	973km
Ø Speed 2	89km/h
Ø Cons 2	10.3l
Trip Time 2	15:23h
Fuel Range	240km

401825-01

- Press the **UP** or **DOWN** button until the **"Trip 2"** menu appears on the matrix display. **"Trip 2"** shows the distance since the last reset, such as between two refueling stops. **"Trip 2"** runs continuously and counts the distance up to **9999**. **"Ø Speed 2"** indicates the average speed based on **"Trip 2"** and **"Trip Time 2"**. **"Ø Cons 2"** indicates the average fuel consumption based on **"Trip 2"** and **"Trip Time 2"**. **"Trip Time 2"** indicates the riding time based on **"Trip 2"** and starts running as soon as a speed signal comes in. **"Fuel Range"** indicates the possible range with the fuel reserve.

Press and hold the **SET** button for 3–5 seconds.

All entries in the **"Trip 2"** menu are cleared.

## 7.10.4 "General Info"

General Info	
Air Temp	14.0°C
Date	01.04.2013
ODO	677km
Battery	13.0V
Oil Temp	75°C

401824-01

- Press the **UP** oder **DOWN** button until the **"General Info"** menu appears on the matrix display.

**"Air Temp"** indicates the ambient air temperature.

**"Date"** indicates the date.

**"ODO"** indicates the total distance covered.

**"Battery"** indicates the battery voltage.

**"Oil Temp"** indicates the engine oil temperature.

## 7.10.5 "TPMS"

TPMS	
FW	2.5
RW	2.9

H01312-01

### Condition

- Model with **TPMS**.



### Warning

**Danger of accidents** The tire pressure control system does not eliminate the necessity to check the tires before going on a ride.

To avoid false alarms, the tire pressure values are evaluated over a period of several minutes.

- Check the tire pressure before every ride.
  - Correct the tire pressure if the tire pressure deviates from the specified value.
  - Even if the tire pressure values are correct, stop the vehicle immediately if its behavior indicates a pressure loss in the tires.
- 
- Press the **UP** or **DOWN** button until the **"TPMS"** menu appears on the matrix display.

## Guideline

Tire air pressure, solo/with passenger/full payload	
Front: with cold tires	2.5 bar (36 psi)
Rear: with cold tires	2.9 bar (42 psi)

The **"TPMS"** menu displays the tire pressure of the front and rear tires.

**"FW"** indicates the tire air pressure at the front.

**"RW"** indicates the tire air pressure at the rear.

## 7.10.6 "Set Favorites"

### Set Favorites

Trip 1	486km
ODO	677km
Fuel Range	240km
Trip Time 2	15:23h
Battery	13.0V

L01441-10

### Condition

- The vehicle is stationary.
- Press the **UP** or **DOWN** button until the **"Set Favorites"** menu appears on the matrix display. Pressing the **SET** button opens the menu.
- Press the **UP** or **DOWN** button to select the menu. Press the **SET** button to set the menu for quick selection.

The **"Favorites"** menu can be configured in the **"Set Favorites"** menu.



## 7.10.7 "Settings"

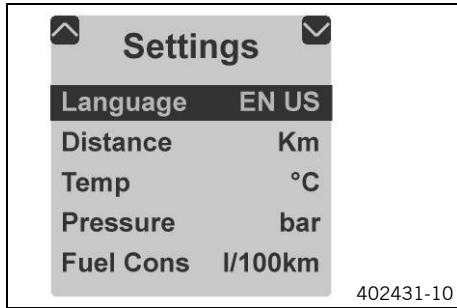

### Condition

- The vehicle is stationary.
- Press the **UP** or **DOWN** button until the **"Settings"** menu appears on the matrix display. Pressing the **SET** button opens the menu.

Settings for units or various values are made in the **"Settings"** menu. Several functions can be enabled or disabled.

## 7.10.8 "Warning"

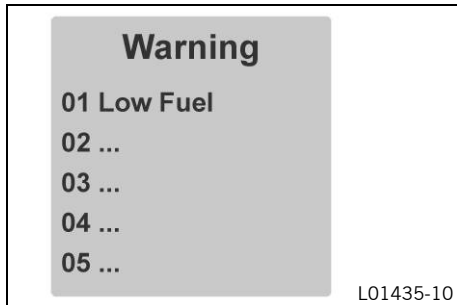

### Condition

- Message or warning
- Press the **UP** or **DOWN** button until the **"Warning"** menu appears on the matrix display. Pressing the **SET** button opens the menu.
- Use the **UP** or **DOWN** button to navigate through the warnings.

In the **"Warning"** menu, warnings that occurred are displayed and stored until they are no longer active.

## 7.10.9 "Heating"

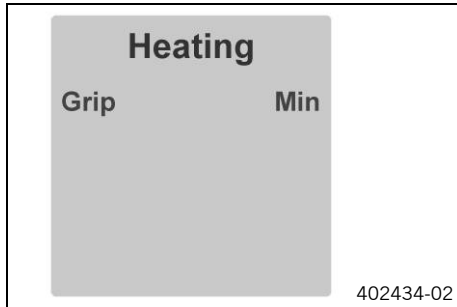

- Press **UP** or **DOWN** button until the **"Heating"** menu appears on the matrix display. Pressing the **SET** button opens the menu.
- Use the **SET** button to select a heating level or to switch off the heated grips.

## 7.10.10 "MTC/ABS"

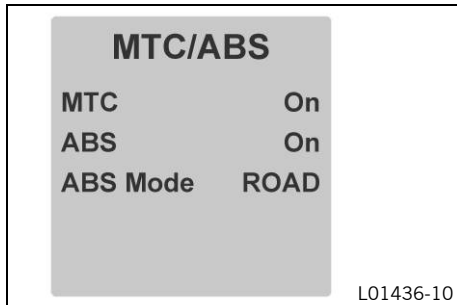

### Condition

- The vehicle is stationary.



### Warning

**Voiding of the government approval for road use and the insurance coverage** If the ABS is switched off completely, the vehicle's approval for road use is invalidated.

- Only operate the vehicle in closed-off areas remote from public road traffic if the ABS is switched off completely.

- Press the **UP** or **DOWN** button until the **"MTC/ABS"** menu appears on the matrix display.

In the **"MTC/ABS"** menu, **"MTC"** and **"ABS"** can be switched off.

In **"ABS Mode"**, you can select between **"ROAD"** and **"SUP MOT"**.



## Info

After the ignition is switched on, motorcycle traction control and ABS are enabled again.

In the **"ROAD"** ABS mode, the ABS controls both wheels.

In the **"SUP MOT"** ABS mode, the ABS only controls the front wheel. There is no ABS intervention on the rear wheel. The ABS lamp flashes slowly to remind you that the **"SUP MOT"** ABS mode is enabled.

In the **"SUP MOT"** ABS mode, the rear wheel may block and there is a risk of crashing.

### 7.10.11 "Load"

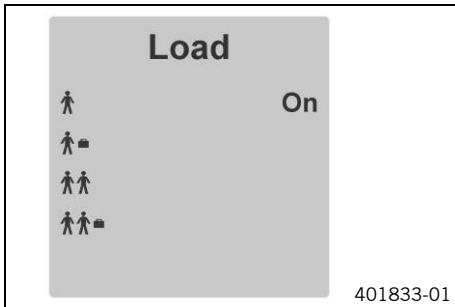

#### Condition

- The vehicle is stationary.
- Engine is running.
- Press the **UP** or **DOWN** button until the **"Load"** menu appears on the matrix display. Pressing the **SET** button opens the menu.
- Press the **UP** or **DOWN** button to select a loading condition and activate it with the **SET** button.

In the **"Load"** menu you can select from four loading conditions.

The setting of the spring preload and the rebound is matched to the load condition.

## 7.10.12 "Damping"



- Press the **UP** or **DOWN** button until the "**Damping**" menu appears on the matrix display. Pressing the **SET** button opens the menu.
- Press the **UP** or **DOWN** button to select a damping setting and activate it with the **SET** button.

In the "**Damping**" menu the settings for "**SPORT**", "**STREET**" and "**COMFORT**" are available.

## 7.10.13 "Drive Mod"

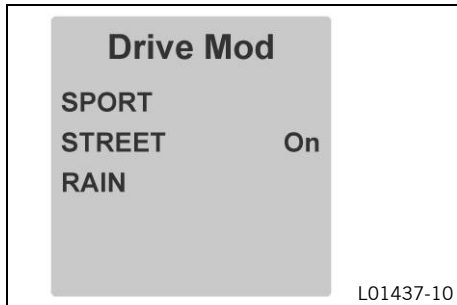

- Press the **UP** or **DOWN** button until the "**Drive Mod**" menu appears on the matrix display. Pressing the **SET** button opens the menu.
- Use the **UP** or **DOWN** button to navigate through the menu. The **SET** button can be used to select engine and traction control settings that are coordinated with each other.
  - ✓ SPORT – homologated performance with very direct response; the traction control allows greater slip on the rear wheel
  - ✓ STREET – homologated performance with balanced response; the traction control allows normal slip on the rear wheel
  - ✓ RAIN – reduced homologated performance for better ridability; the traction control allows normal slip on the rear wheel



## 7.10.14 menu overview

**General Info**

Air Temp	14.0°C
Date	01.04.2016
ODO	677km
Battery	13.0V
Oil Temp	75°C

**TPMS**

FW	2.5 bar
RW	2.9 bar

**Set Favorites**

Trip 1	486km
Trip 2	973km
Fuel Range	240km
Trip Time 2	15:23h
Battery	13.0V

**Settings**

Language	EN US
Distance	Km
Temp	°C
Volume	litre
Pressure	bar

**Warnings**

- 01 Low Beam Lamp
- 02 ...
- 03 ...
- 04 ...
- 05 ...

**Heating**

Grip	Max
------	-----

**MTC/ABS**

MTC	On
ABS	On
ABS Mode	ROAD

**Drive Mod**

SPORT	
STREET	On
RAIN	

**Favorites**

Trip 1	486km
Trip 2	973km
Fuel Range	240km
Trip Time 2	15:23h
Battery	13.0V

**Trip 1**

Trip 1	973km
Ø Speed 1	89km/h
Ø Cons 1	10.3l
Trip Time 1	15:23h
Fuel Range	240km

**Trip 2**

Trip 2	973km
Ø Speed 2	89km/h
Ø Cons 2	10.3l
Trip Time 2	15:23h
Fuel Range	240km

**KTM**  
**READY TO RACE**  
**Service: 1000km**  
**02/2016**

# 7 COMBINATION INSTRUMENT

---

KTM start screen

---

Menu buttons

---

**"Favorites"**

---

**"Trip 1"**

---

**"Trip 2"**

---

**"General info"**

---

**"TPMS"** (only active if TPMS is available)

---

**"Set Favorites"**

---

**"Settings"**

---

**"Warning"** (only active if there are messages)

---

**"Heating"**

---

**"MTC/ABS"**

---

**"Load"**

---

**"Damping"**

---

**"Drive Mod"**

---

## 7.10.15 "Language"

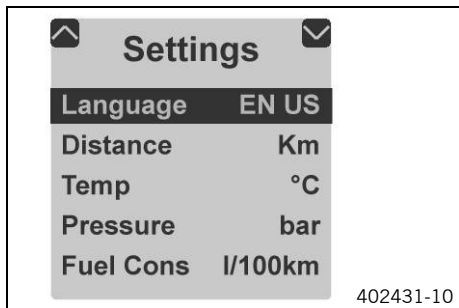

### Condition

- The vehicle is stationary.
- Press the **UP** or **DOWN** button until the "**Settings**" menu appears on the matrix display. Pressing the **SET** button opens the menu.
- Press the **SET** button again to select the language.

The menu languages are US English, UK English, German, Italian, French, and Spanish.

## 7.10.16 "Distance"

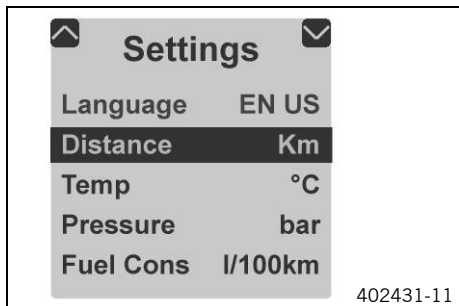

### Condition

- The vehicle is stationary.
- Press the **UP** or **DOWN** button until the "**Settings**" menu appears on the matrix display. Pressing the **SET** button opens the menu.
- Press the **UP** or **DOWN** button until "**Distance**" is highlighted in black on the matrix display. Pressing the **SET** button again sets the unit of measure.

Select kilometers "**km**" or miles "**mi**" for the distance.



## 7.10.17 "Temp"

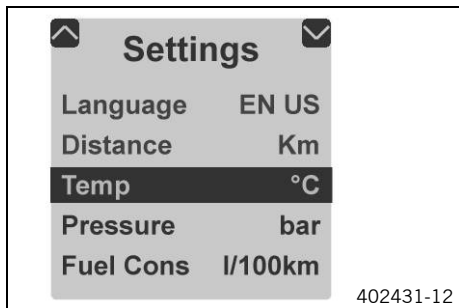

### Condition

- The vehicle is stationary.
- Press the **UP** or **DOWN** button until the **"Settings"** menu appears on the matrix display. Pressing the **SET** button opens the menu.
- Press the **UP** or **DOWN** button until **"Temp"** is highlighted in black on the matrix display. Pressing the **SET** button again sets the unit of measure.

Select **"°C"** or **"°F"** for the temperature indicator.

## 7.10.18 "Pressure"

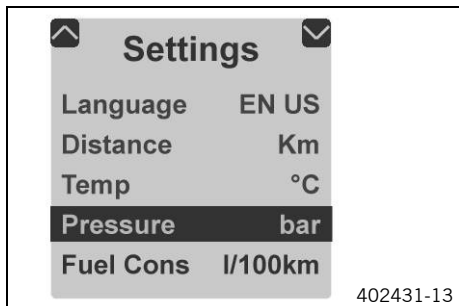

### Condition

- The vehicle is stationary.
- Press the **UP** or **DOWN** button until the **"Settings"** menu appears on the matrix display. Pressing the **SET** button opens the menu.
- Press the **UP** or **DOWN** button until **"Pressure"** is highlighted in black on the matrix display. Pressing the **SET** button again sets the unit of measure.

Select **"bar"** or **"psi"** as the unit.

## 7.10.19 "Fuel Cons"

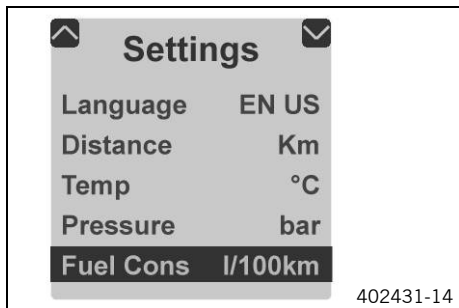

### Condition

- The vehicle is stationary.
- Press the **UP** or **DOWN** button until the "**Settings**" menu appears on the matrix display. Pressing the **SET** button opens the menu.
- Press the **UP** or **DOWN** button until "**Fuel Cons**" is highlighted in black on the matrix display. Pressing the **SET** button again sets the unit of measure.

Select one of the available consumption displays.

## 7.10.20 "Clock/Date"

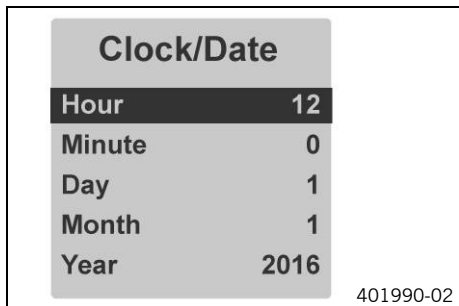

### Condition

- The vehicle is stationary.
- Press the **UP** or **DOWN** button until the "**Settings**" menu appears on the matrix display. Pressing the **SET** button opens the menu.
- Press the **UP** or **DOWN** button until "**Clock/Date**" is highlighted in black on the matrix display. Pressing the **SET** button again opens the menu.
- Use the **UP** or **DOWN** button to navigate through the menu. Use the **SET** button to set the time and date.

If the battery was disconnected from the vehicle, the time and date must be set in the matrix display.

## 7.10.21 "Shift Light"

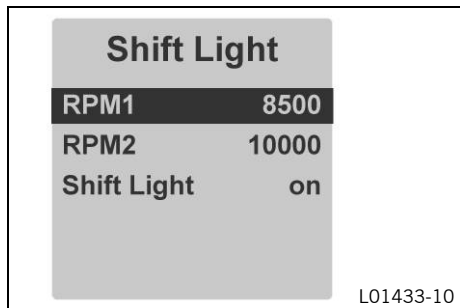

### Condition

- The vehicle is stationary.
  - Press the **UP** or **DOWN** button until the "**Settings**" menu appears on the matrix display. Pressing the **SET** button opens the menu.
  - Press the **UP** or **DOWN** button until "**Shift Light**" is highlighted in black on the matrix display. Pressing the **SET** button again opens the menu.
  - Press the **UP** or **DOWN** button to select the function. Use the **SET** button to set the engine speed for the shift warning light.

When the engine speed reaches "**RPM 1**", the shift warning light flashes.

When the engine speed reaches "**RPM 2**", the shift warning light lights up continuously.

Switch the "**Shift Light**" function on or off.

## 7.10.22 "Heat Grip"

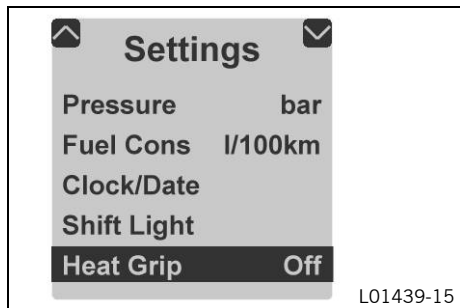

### Condition

- The vehicle is stationary.
  - Press the **UP** or **DOWN** button until the "**Settings**" menu appears on the matrix display. Pressing the **SET** button opens the menu.
  - Press the **UP** or **DOWN** button until "**Heat Grip**" is highlighted in black on the matrix display. Pressing the **SET** button again switches the heated grips menu on or off.

Switch the heated grips menu on and off.

## 7.10.23 "cLightTest"

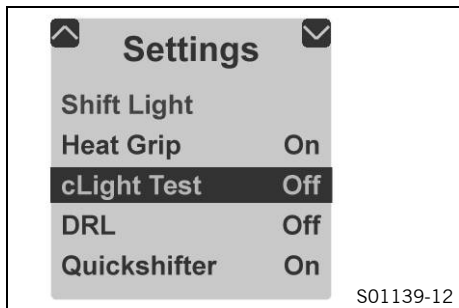

### Condition

- The vehicle is stationary.
- Press the **UP** or **DOWN** button until the "**Settings**" menu appears on the matrix display. Pressing the **SET** button opens the menu.
- Press the **UP** or **DOWN** button until "**cLightTest**" is highlighted in black on the matrix display. Pressing the **SET** button again starts the cornering light test.

The left-hand cornering light segments light up in succession, starting with the lower segment.

If the left cornering light test is complete, the upper segment lights up continuously.

By pressing the **SET** button again the right cornering light test is repeated.

If the test of the right light curve is complete, the upper segment lights up continuously.

By pressing the **SET** button again the test is ended and the cornering light switched off.

## 7.10.24 "DRL"

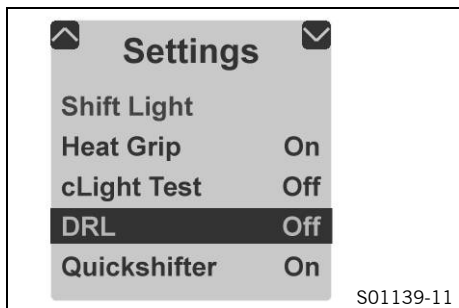

### Condition

- The vehicle is stationary.
- Press the **UP** or **DOWN** button until the "**Settings**" menu appears on the matrix display. Pressing the **SET** button opens the menu.
- Press the **UP** or **DOWN** button until "**DRL**" is highlighted in black on the matrix display. Pressing the **SET** button again switches the daytime running light on or off.

Switch the daytime running light on or off.



### Info

Note the legal regulations regarding the daytime running light.

## 7.10.25 "Quickshifter"

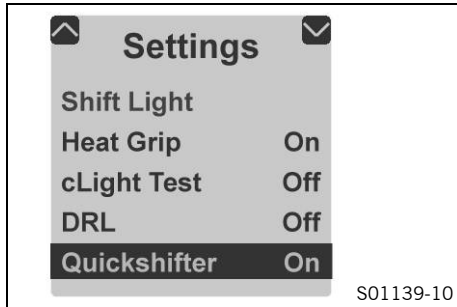

### Condition

- The vehicle is stationary.
  - Press the **UP** or **DOWN** button until the "**Settings**" menu appears on the matrix display. Pressing the **SET** button opens the menu.
  - Press the **UP** or **DOWN** button until "**Quickshifter**" (🗨️ p. 85) is highlighted in black on the matrix display. Pressing the **SET** button again switches the quickshifter on or off.
- Switch the quickshifter on or off.

## 8.1 Handlebar position

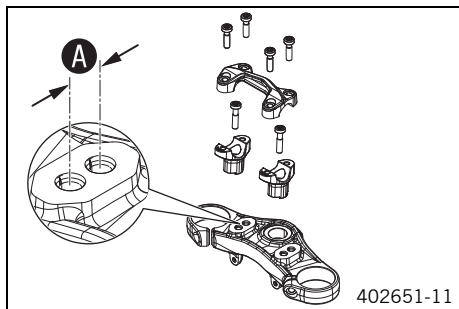

On the upper triple clamp there are two holes at a distance of **A** apart.

Hole distance <b>A</b>	15 mm (0.59 in)
------------------------	-----------------

The handlebar supports can be turned through 180 °.

The handlebar can be mounted in four different positions. In this way, the handlebar can be mounted in the most comfortable position for the rider.

## 8.2 Adjusting the handlebar position 🛠️



### Warning

**Danger of accidents** A repaired handlebar poses a safety risk.

If the handlebar is bent or straightened, the material becomes fatigued. The handlebar may break as a result.

- Change the handlebar if the handlebar is damaged or bent.

# 8 ERGONOMICS

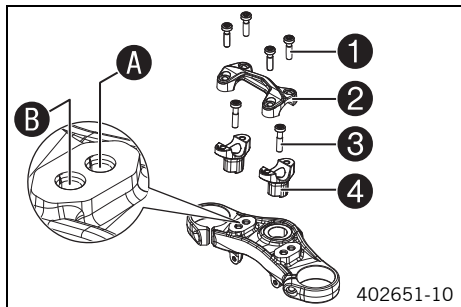

- Remove screws ①. Take off handlebar clamp ②. Take off the handlebar and place it to the rear.



**Info**

Cover the components to protect them against damage.  
Do not kink the cables and lines.

- Remove screws ③. Take off handlebar supports ④.
- Position the handlebar supports in the desired orientation above hole A or B.



**Info**

The handlebar supports are longer and higher on one side.  
Position the left and right handlebar supports evenly.

- Mount and tighten screws ③.

Guideline

Screw, handlebar support	M10	40 Nm (29.5 lbf ft)	Loctite® 243™
--------------------------	-----	------------------------	---------------

- Position the handlebar.



**Info**

Make sure the cables and wiring are positioned correctly.

- Position the handlebar clamp. Mount screws ① but do not tighten yet.
  - ✓ Marking C on the handlebar scale is aligned with the top edge of the handlebar clamp.
  - ✓ Center line D on the handlebar scale is aligned with the center of the handlebar clamp.
- First bolt the handlebar support with screws ① onto the longer, higher side of the handlebar supports so that both parts touch.

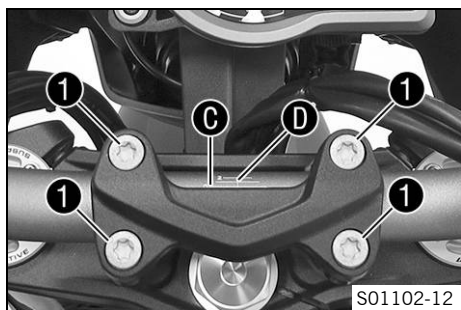

- Tighten screws ❶ evenly.

Guideline

Screw, handlebar clamp	M8	20 Nm (14.8 lbf ft)
------------------------	----	------------------------

## 8.3 Adjusting the windshield



### Info

Do not make any adjustments while riding.

- Push the windshield in the direction of travel.
  - ✓ The windshield is unlocked.

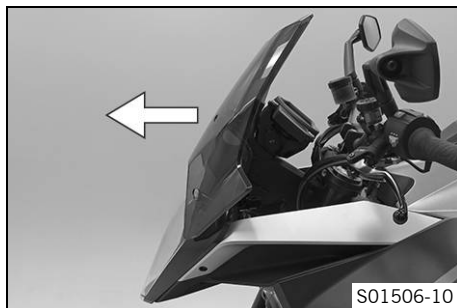



## 8 ERGONOMICS

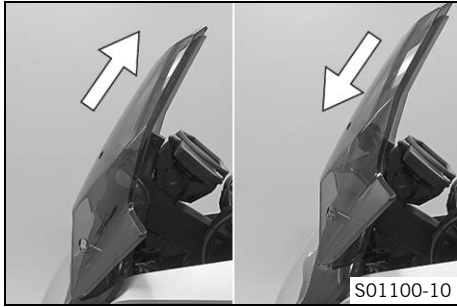

- To move the windshield to the desired position, push the windshield upward or downward.

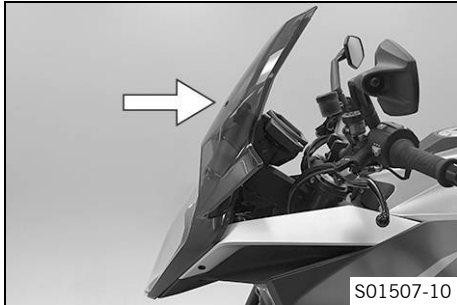

- Push the windshield into the locking mechanism against the direction of travel.
  - ✓ The windshield is locked.

## 8.4 Adjusting the basic position of the clutch lever

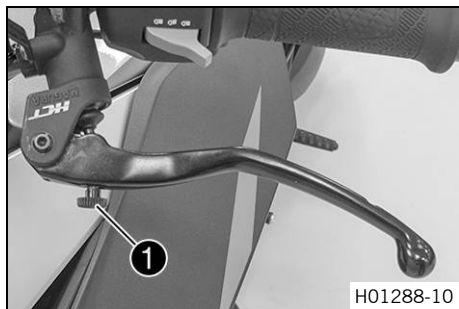

- Push the clutch lever forward.
- Adjust the basic position of the clutch lever to your hand size by turning adjusting screw ①.

### **i** Info

Turn the adjusting screw clockwise to increase the distance between the clutch lever and the handlebar.  
Turn the adjusting screw counterclockwise to decrease the distance between the clutch lever and the handlebar.  
The range of adjustment is limited.  
Only turn the adjusting screw by hand, and do not use force.  
Do not make any adjustments while riding.

## 8.5 Adjusting the basic position of the hand brake lever

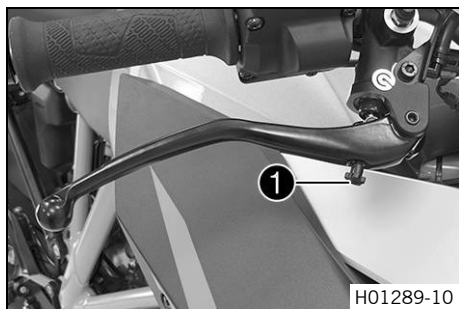

- Push the hand brake lever forward.
- Adjust the basic position of the hand brake lever to your hand size by turning adjusting screw ①.

### **i** Info

Turn the adjusting screw clockwise to increase the distance between the hand brake lever and the handlebar.  
Turn the adjusting screw counterclockwise to decrease the distance between the hand brake lever and the handlebar.  
The range of adjustment is limited.  
Only turn the adjusting screw by hand, and do not use force.  
Do not make any adjustments while riding.

## 8.6 Adjusting the basic position of the foot brake lever ↘

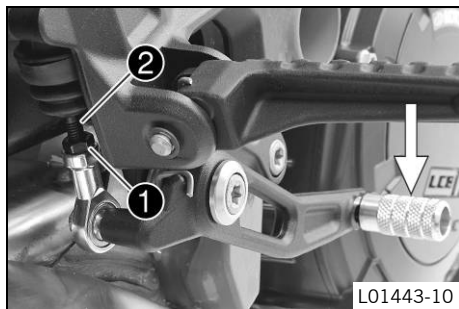

- Loosen nut ①.
- Press the foot brake lever down to be able to turn push rod ② more easily.
- Turn the push rod until the foot brake lever is in the desired position.

---

### **i** Info

The range of adjustment is limited.  
The screw must be screwed into the ball joint by at least five turns.

---

- Lock nut ①.

## 8.7 Setting the step plate of the foot brake lever

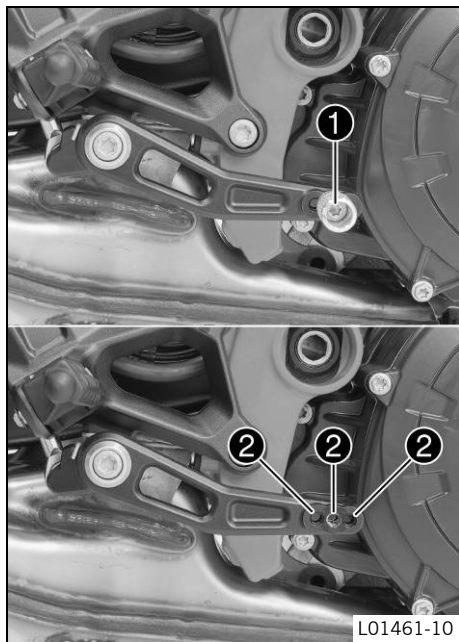

- Remove screw ❶ together with the foot plate of the foot brake lever.
- To adjust the length of the foot brake lever, position the step plate of the foot brake lever using screw ❶ in a drill hole ❷.

Guideline

Standard	Middle hole
----------	-------------

- Tighten screw ❶.

Guideline

Screw, step plate for foot brake lever	M6	10 Nm (7.4 lbf ft)	Loctite® 243™
--	----	-----------------------	---------------

## 8.8 Checking the basic position of the shift lever

### **i** Info

When driving, the shift lever must not touch the rider's boot when in the basic position. If the shift lever is permanently touching the boot, the transmission will be subject to excessive load; this can cause a malfunction of the quickshifter.

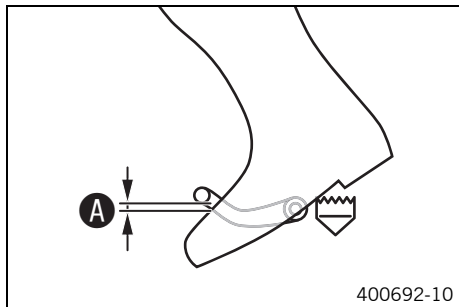

- Sit on the vehicle in the riding position and determine distance **A** between the upper edge of your boot and the shift lever.

Distance between shift lever and upper edge of boot	10... 20 mm (0.39... 0.79 in)
---	-------------------------------

- » If the distance does not meet specifications:
  - Adjust the basic position of the shift lever. 🛠️ (p. 75)

## 8.9 Adjusting the basic position of the shift lever 🛠️

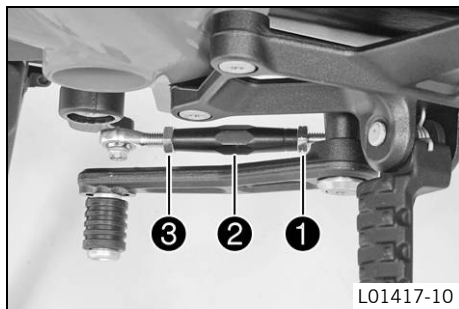

- Loosen nut **1**, holding the threaded rod **2**.

**i Info**  
Nut **1** has a left-handed thread.

- Loosen nut **3**, holding the threaded rod **2**.
- Turn threaded rod **2** to adjust the shift lever.

**i Info**  
The range of adjustment is limited.  
The shift lever must not come into contact with any other vehicle components during the shift procedure.

- Tighten nut **3**, holding the threaded rod **2**.

Guideline

Nut, shift rod	M8	12 Nm (8.9 lbf ft)
----------------	----	--------------------

- Tighten nut ①, holding the threaded rod ②.

Guideline

Nut, shift rod	M8LH	12 Nm (8.9 lbf ft)
----------------	------	--------------------

## 8.10 Setting the shift lever stub

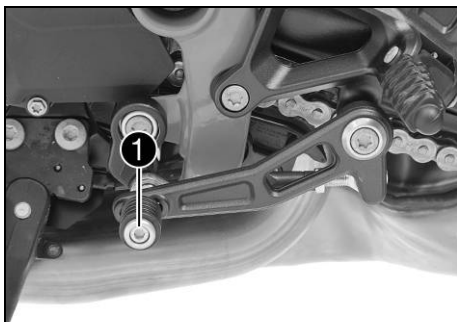

- Remove screw ① along with the shift lever stub.
- Position the shift lever stub with the screw in one of the drilled holes ② depending on the desired lever length.

Guideline

Standard	Middle hole
----------	-------------

- Tighten the screw.

Guideline

Screw, shift lever stub	M6	10 Nm (7.4 lbf ft)	Loctite® 243™
-------------------------	----	-----------------------	---------------

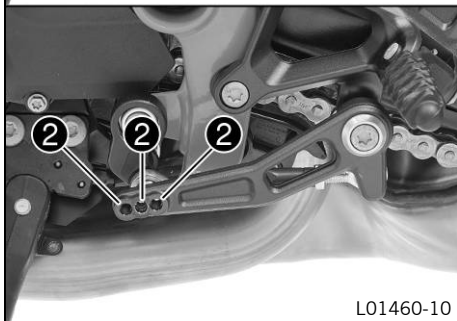

L01460-10

## 9.1 Advice on first use



### **Danger**

**Danger of accidents** A rider who is not fit to ride poses a danger to him or herself and others.

- Do not operate the vehicle if you are not fit to ride due to alcohol, drugs or medication.
- Do not operate the vehicle if you are physically or mentally impaired.



### **Warning**

**Risk of injury** Missing or poor protective clothing presents an increased safety risk.

- Wear appropriate protective clothing such as helmet, boots, gloves as well as trousers and a jacket with protectors on all rides.
- Always wear protective clothing that is in good condition and meets the legal regulations.



### **Warning**

**Danger of crashing** Different tire tread patterns on the front and rear wheel impair the handling characteristic. Different tire tread patterns can make the vehicle significantly more difficult to control.

- Make sure that only tires with a similar tire tread pattern are fitted to the front and rear wheel.



### **Warning**

**Danger of accidents** Non-approved or non-recommended tires and wheels impact the handling characteristic.

- Only use tires/wheels approved by KTM with the corresponding speed index.



### **Warning**

**Danger of accidents** Reduced road grip with new tires.

- New tires have a smooth rolling surface and therefore cannot provide full road grip. The entire rolling surface must be roughened in the first 200 kilometers (124.3 miles) by moderate riding at alternating angles. The full grip levels are not achieved until the tires have been run in.



## Warning

- Danger of accidents** The brake system fails in the event of overheating.  
If the foot brake lever is not released, the brake linings drag continuously.
- Take your foot off the foot brake lever when you are not braking.



## Info

When using your vehicle, remember that others may feel disturbed by excessive noise.

- Make sure that the pre-delivery inspection work has been carried out by an authorized KTM workshop.
  - ✓ You receive a delivery certificate and the Service and Warranty Booklet at vehicle handover.
- Before your first trip, read the entire Owner's Manual carefully.
- Get to know the controls.
- Adjust the motorcycle to your requirements, as described in the "Ergonomics" chapter.
- Get used to handling the motorcycle on a suitable piece of land before making a longer trip. Try also to ride as slowly as possible and in a standing position to get a better feeling for the motorcycle.
- Hold the handlebar firmly with both hands and keep your feet on the footrests when riding.
- Run the engine in.

## 9.2 Running in the engine

- During the running-in phase, do not exceed the specified engine speed.

Guideline

Maximum engine speed	
During the first: 1,000 km (620 mi)	6,500 rpm
After the first: 1,000 km (620 mi)	10,500 rpm



**Tip**

During the running-in phase, set the shift warning light to the specified engine speed.

- Avoid fully opening the throttle!

## 9.3 Loading the vehicle

**Warning**

**Danger of accidents** Unstable handling characteristics.

- Do not exceed the maximum permitted weight and axle loads. The overall weight consists of: motorcycle operational and with a full tank, driver and passenger with protective clothing and helmet, baggage.

**Warning**

**Danger of accidents** Unstable handling characteristics due to incorrect mounting of suitcase and/or tank rucksack.

- Mount and secure suitcase and tank rucksack according to the manufacturer's instructions.

**Warning**

**Danger of accidents** Unstable handling characteristics at high speed.

- Adapt your speed according to your payload. Ride more slowly if your motorcycle is loaded with cases or other baggage.  
Maximum speed with luggage 130 km/h (80.8 mph)

**Warning**

**Danger of accidents** Destruction of luggage carrier system.

- If the motorcycle is fitted with luggage cases, note the manufacturer's specifications concerning the maximum payload.

**Warning**

**Danger of accidents** Poor visibility for other road users due to slipped baggage.

- If the tail light is covered, you are less visible to traffic behind you, especially when it is dark. Check that your baggage is fixed properly at regular intervals.

# 9 PREPARING FOR USE

 **Warning**  
**Danger of accidents** Changed handling characteristics and longer stopping distance with excessive payload.  
– Adapt your speed according to your payload.

 **Warning**  
**Danger of accidents** Unstable handling characteristics due to slipped baggage.  
– Check the way your baggage is fixed regularly.

 **Warning**  
**Danger of burns** A hot exhaust system can burn baggage.  
– Fasten your baggage in such a way that it cannot be burned or singed by the hot exhaust system.

- 
- If you carry luggage, make sure you secure it firmly as close as possible to the center of the vehicle and ensure even weight distribution between the front and rear wheels.
  - Do not exceed the maximum permissible weight and the maximum permissible axle loads.

### Guideline

Maximum permissible overall weight	456 kg (1,005 lb.)
Maximum permissible front axle load	165 kg (364 lb.)
Maximum permissible rear axle load	320 kg (705 lb.)

## 10.1 Checks and maintenance measures when preparing for use



### Info

Before every trip, check the condition of the vehicle and ensure that it is roadworthy. The vehicle must be in perfect technical condition when it is being operated.

- Check the engine oil level. (📖 p. 181)
- Check the front brake fluid level. (📖 p. 130)
- Check the rear brake fluid level. (📖 p. 134)
- Check the front brake linings. (📖 p. 133)
- Check the brake linings of the rear brake. (📖 p. 137)
- Check that the brake system is functioning properly.
- Check the coolant level in the compensating tank. (📖 p. 175)
- Check the chain for dirt. (📖 p. 112)
- Check the chain tension. (📖 p. 114)
- Check the tire condition. (📖 p. 145)
- Check the tire air pressure. (📖 p. 147)
- Check the settings of all controls and ensure that they can be operated smoothly.
- Check that the electrical equipment is functioning properly.
- Check that luggage is properly secured.
- Check the setting of the rear mirror.
- Check the fuel level.

## 10.2 Starting



### Danger

**Danger of poisoning** Exhaust gases are toxic and inhaling them may result in unconsciousness and death.

- Always make sure there is sufficient ventilation when running the engine.
- Use an effective exhaust extraction system when starting or running the engine in an enclosed space.



### Caution

**Danger of accidents** If the vehicle is operated with a discharged battery or without a battery, electronic components and safety equipment may be damaged.

- Never operate the vehicle with a discharged battery or without a battery.

### Note

**Engine damage** High revving speed with a cold engine negatively impacts the lifespan of the engine.

- Always run the engine warm at a low speed.

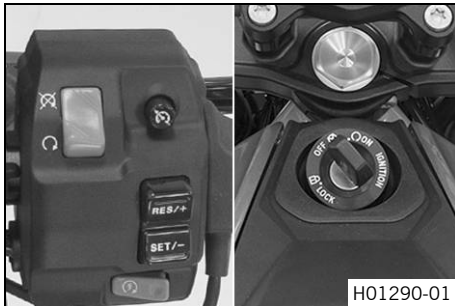

- Press the emergency OFF switch to the position **ON** ○.
- Switch on the ignition by turning the black ignition key to the position **ON** ○.
  - ✓ After you switch on the ignition, you can hear the fuel pump working for about two seconds. The function check of the combination instrument is run at the same time.
  - ✓ The ABS warning lamp lights up and goes back out after starting off.
- Shift the transmission to idle **N**.
  - ✓ The green idling speed indicator lamp **N** lights up.



- Press the electric starter button (⚡).

## **i** Info

Do not press the electric starter button until the combination instrument function check is finished.

When starting, **DO NOT** open the throttle. If you open the throttle during the starting procedure, fuel is not injected by the engine management system and the engine cannot start.

Press the electric starter button (⚡) for at most 5 seconds. Wait for at least 5 seconds before trying again.

This motorcycle is equipped with a safety starting system. You can only start the engine if the transmission is in neutral or if the clutch lever is pulled when a gear is engaged. If the side stand is folded out and you shift into gear, the engine stops.

- Remove the motorcycle from the side stand.

## 10.3 Starting off

- Pull the clutch lever, shift into first gear, release the clutch lever slowly and at the same time open the throttle gently.

## 10.4 Start off with HHC (Option: Hill-start assist)

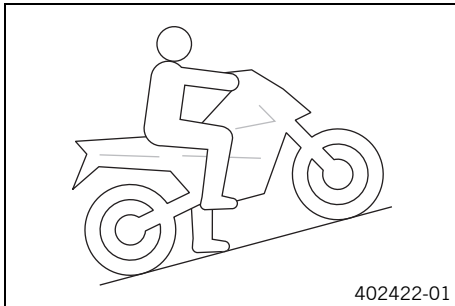

The **HHC** is an optional auxiliary function of the brake system.

The **HHC** prevents accidental rolling back of the motorcycle on hills.

The **HHC** recognizes stopping on hills and operates the rear brake.

After releasing the brake lever, the brake force is maintained for a maximum of 5 seconds as long as the motorcycle is not moving forward.

When driving off the **HHC** releases the rear brake automatically.

**Info**

When the **HHC** is active, the TC light  flashes

When the ignition is switched on, the **HHC** can still be active, even if the engine is stopped.

To roll back with active **HHC**, wait 5 seconds, shift to neutral, or switch off the ignition.

---

If the **HHC** does not detect a start off after 5 seconds, the braking force is automatically reduced gently.

When a brake lever is actuated, the **HHC** is re-activated.

## 10.5 Quickshifter

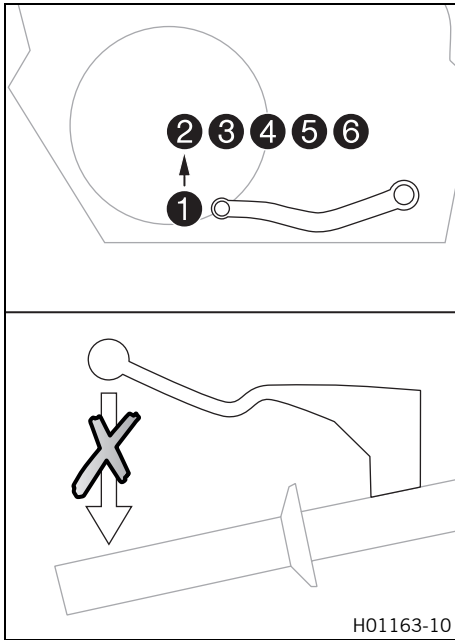

When the quickshifter is activated, you can shift up under load without actuating the clutch.

Because there is no need to close the throttle grip, uninterrupted gear shifts are possible. The quickshifter uses the shifter shaft position to check whether or not a shift should be initiated, and sends a corresponding signal to the engine control.

If the quickshifter is disabled in the combination instrument, the clutch needs to be actuated in the normal way for each shift.

The quickshifter does not support down-shifting, shifting in overrun condition, or shifting in zero-load condition.

## 10.6 Shifting, riding



### Warning

**Danger of accidents** Abrupt load alterations can cause the vehicle to get out of control.

- Avoid abrupt load alterations and sudden braking actions, and adapt your speed to the road conditions.



## Warning

**Danger of accidents** If you change down at high engine speed, the rear wheel blocks and the engine races.

- Do not change into a low gear at high engine speed.



## Warning

**Danger of accidents** Malfunctions caused by incorrect ignition key position.

- Do not change the ignition key position during a journey.



## Warning

**Danger of accidents** Distraction from traffic activity by adjustments to the vehicle.

- Make all adjustments when the vehicle is at a standstill.



## Warning

**Risk of injury** Falling off of the passenger.

- The passenger must be seated properly on the passenger seat and hold on to the front rider or the grab handles. The feet must be positioned on the passenger footrests. Note the regulations governing the minimum age of passengers.



## Warning

**Danger of accidents** Danger of accidents caused by dangerous driving.

- Comply with traffic regulations and ride defensively and foresightedly to detect sources of danger early on.



## Warning

**Danger of accidents** Reduced road grip with cold tires.

- On every journey, take the first miles carefully at moderate speed until the tires reach operating temperature and optimal road grip is ensured.





## Warning

**Danger of accidents** Reduced road grip with new tires.

- New tires have a smooth rolling surface and therefore cannot provide full road grip. The entire rolling surface must be roughened in the first 200 kilometers (124.3 miles) by moderate riding at alternating angles. The full grip levels are not achieved until the tires have been run in.



## Warning

**Danger of accidents** Unstable handling characteristics.

- Do not exceed the maximum permitted weight and axle loads. The overall weight consists of: motorcycle operational and with a full tank, driver and passenger with protective clothing and helmet, baggage.



## Warning

**Danger of accidents** Unstable handling characteristics due to slipped baggage.

- Check the way your baggage is fixed regularly.



## Warning

**Danger of accidents** Lack of roadworthiness.

- After a fall, check the vehicle as usual before preparing for use.

## Note

**Engine damage** Unfiltered intake air has a negative effect on the service life of the engine.

Dust and dirt will enter the engine without an air filter.

- Never start to use the vehicle without an air filter.

## Note

**Engine failure** Overheating damages the engine.

- If the coolant temperature warning is displayed, stop immediately and take care not to endanger yourself or other traffic participants in the process.
- Allow the engine and cooling system to cool down.

- Check and, if necessary, correct the coolant level on the cooling system while it is in a cooled state.

## Note

**Transmission damage** Incorrect use of the quickshifter will damage the transmission.

The quickshifter is only active when shifting up under load.

The quickshifter can only be used if the function is enabled in the combination instrument.

The quickshifter is not active if you pull the clutch lever.

- Use the quickshifter only to shift up under load.  
Engine speed before gear shift > 2,500 rpm
- To shift in overrun condition or in load-free condition, use the clutch lever for shifting.
- Pull the clutch lever to shift down.



## Info

If unusual noises occur while riding, stop immediately, switch off the engine and contact an authorized KTM workshop.

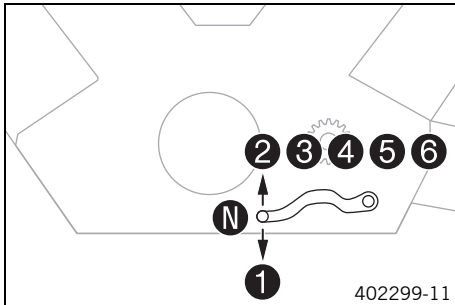

- Shift into a higher gear when conditions allow (incline, road situation, etc.).
- Release the throttle while simultaneously pulling the clutch lever, shift into the next gear, release the clutch lever, and open the throttle.



## Info

You can see the positions of the 6 forward gears in the figure. The idle position is between the first and second gears. First gear is used for starting off or for steep inclines.

- If the quickshifter is enabled in the combination instrument, you can shift up under load without pulling the clutch lever.

## Guideline

Engine speed before gear shift	> 2,500 rpm
--------------------------------	-------------

---

 **Info**

Pull the shift lever quickly back to the stop without changing the throttle twist grip position.



---

- After reaching maximum speed by fully opening the throttle grip, turn the throttle back so it is  $\frac{3}{4}$  open. This will barely reduce the speed but fuel consumption will be considerably lower.
  - Accelerate only up to a speed suitable for the road surface and weather conditions. Particularly in bends, do not shift, and accelerate very carefully.
  - Brake if necessary and close the throttle at the same time in order to shift down.
  - Pull the clutch lever and shift into a lower gear, release the clutch lever slowly, and open the throttle or shift again.
- 

 **Info**

Even if the quickshifter is enabled in the combination instrument, you still need to pull the clutch lever to shift down.

---

- If the engine stalls (e.g. at a crossroads), just pull the clutch lever and press the electric starter button. You do not have to shift into neutral.
  - Switch off the engine if running at idle or standing for a long time.
  - If the oil pressure warning lamp  lights up during a trip, stop immediately and switch off the engine. Contact an authorized KTM workshop.
  - If the engine warning lamp  lights up while riding, stop immediately taking care not to endanger yourself or other road users in the process.
  - If the general warning lamp  lights up during a trip, the matrix display shows a message for 10 seconds.
- 

 **Info**

Very important messages are stored in the **"Warning"** menu.

---

- If the icy road symbol ❄️ appears in the combination instrument, the roads may be icy. Adjust your speed to the road conditions.

## 10.7 MSR (Option: Engine braking control)

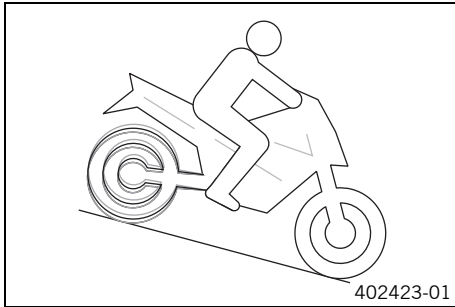

The **MSR** is an optional auxiliary function of the engine control.

If the engine braking effect is too great, the **MSR** prevents the rear wheel from locking or sliding away on a sloping position.

To avoid slip of the rear wheel, the **MSR** only opens the throttle valve as far as absolutely necessary.

The **MSR** is applied on surfaces, where the friction is too low to open the anti-hopping clutch.

To further increase ride safety, the **MSR** is slope dependent.

### Info

If ABS is disabled, MTC is disabled or Drive Mode Sup Mot (📖 p. 179) is enabled, the **MSR** is not active.

## 10.8 Applying the brakes



### Warning

**Danger of accidents** Moisture and dirt impair the brake system.

- Brake carefully several times to dry out and remove dirt from the brake linings and the brake discs.



### Warning

**Danger of accidents** A spongy pressure point on the front or rear brake reduces braking efficiency.

- Check the brake system and do not continue riding until the problem is eliminated. (Your authorized KTM workshop will be glad to help.)



## Warning

**Danger of accidents** The brake system fails in the event of overheating. If the foot brake lever is not released, the brake linings drag continuously.

- Take your foot off the foot brake lever when you are not braking.



## Warning

**Danger of accidents** Longer stopping distance due to higher overall weight.

- Take the longer stopping distance into account when carrying a passenger and baggage.



## Warning

**Danger of accidents** Delayed brake action on salted roads.

- There may be salt deposits on the brake discs. In order to restore the normal braking efficiency, you will need to remove the deposits from the discs by carefully applying the brakes.



## Warning

**Danger of accidents** Greater stopping distance due to ABS.

- Braking should be appropriate to the driving situation and the road conditions.



## Warning

**Danger of accidents** Very forceful braking can cause the wheels to block.

- ABS must be switched on to be effective.



## Warning

**Danger of accidents** Vehicle rollover

- It is not always possible to prevent vehicle rollover in extreme riding situations (e. g. luggage loaded with a high center of gravity, varying road surfaces, steep descents, full braking without disengaging the gear). Adapt your riding style to the road conditions and your driving ability.
-

- When braking, release the throttle and apply the front and rear brakes at the same time.

**Info**

When the ABS is enabled, you can achieve maximum braking power even on low grip surfaces such as sandy, wet, or slippery terrain without locking of the wheels.

---

**Warning**

**Danger of accidents** The rear wheel can lock due to the engine braking effect.

- Pull in the clutch, if you perform emergency or full braking, or if you brake on a slippery ground.

**Warning**

**Danger of accidents** Banked or laterally sloping ground reduces the maximum possible delay.

- If possible finish braking before going into a bend.
- 

- Always finish braking before you go into a bend. Change down to a lower gear appropriate to your road speed.
- Use the braking effect of the engine on long downhill stretches. Change down one or two gears, but do not over-rev the engine. In this way, you have to brake far less and the brakes do not overheat.

## 10.9 Stopping, parking

---

**Warning**

**Risk of misappropriation** Usage by unauthorized persons.

- Never leave the vehicle unattended while the engine is running. Secure the vehicle against use by unauthorized persons. If you leave the vehicle, lock the steering and remove the ignition key.

**Warning**

**Danger of burns** Some vehicle components become very hot when the vehicle is operated.

- Do not touch any parts such as the exhaust system, radiator, engine, shock absorber, or brake system before the vehicle parts have cooled down.
- Let the vehicle parts cool down before you perform any work on the vehicle.

## Note

**Material damage** The vehicle may be damaged by incorrect procedure when parking. Significant damage may be caused if the vehicle rolls away or falls over. The components for parking the vehicle are designed only for the weight of the vehicle.

- Park the vehicle on a firm and level surface.
- Ensure that nobody sits on the vehicle when the vehicle is parked on a stand.

## Note

**Fire hazard** Hot vehicle components pose a fire hazard and explosion risk.



- Do not park the vehicle near to materials which are highly flammable or explosive.
- Allow the vehicle to cool down before covering it.

- 
- Apply the brakes on the motorcycle.
  - Shift the transmission to idle **N**.
  - Switch off the ignition by turning the black ignition key to the position **OFF** .



## Info

If the engine is switched off with the emergency OFF switch and the ignition remains switched on at the ignition lock, power continues to flow to most power consumers. This discharges the battery. You should therefore always switch off the engine with the ignition key – the emergency OFF switch is intended for emergencies only.

- 
- Park the motorcycle on a firm surface.
  - Swing the side stand forward with your foot as far as it will go and lean the vehicle on it.
  - Lock the steering by turning the handlebar to the left, pressing the black ignition key down in the position **OFF**  and turning it to the position **LOCK** . To make the steering lock engage more easily, move the handlebar a little to the left and right. Remove the black ignition key.

## 10.10 Transport

### Note

**Danger of damage** The parked vehicle can roll away or fall over.

- Park the vehicle on a firm and level surface.

### Note

**Fire hazard** Hot vehicle components pose a fire hazard and explosion risk.

- Do not park the vehicle near to materials which are highly flammable or explosive.
- Allow the vehicle to cool down before covering it.

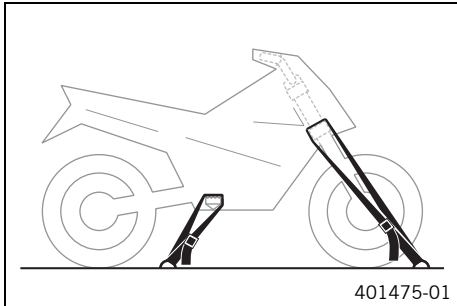

- Switch off the engine.
- Use tension belts or other suitable devices to secure the motorcycle against accidents or falling over.



## 10.11 Refueling



### **Danger**

**Fire hazard** Fuel is highly flammable.

The fuel in the fuel tank expands when warm and can escape if overfilled.

- Do not refuel the vehicle in the vicinity of open flames or lit cigarettes.
- Switch off the engine for refueling.
- Make sure that no fuel is spilled; particularly not on hot parts of the vehicle.
- If any fuel is spilled, wipe it off immediately.
- Observe the specifications for refueling.



### **Warning**

**Danger of poisoning** Fuel is poisonous and a health hazard.

- Avoid skin, eye and clothing contact with fuel.
- Immediately consult a doctor if you swallow fuel.
- Do not inhale fuel vapors.
- In case of skin contact, rinse the affected area with plenty of water.
- Rinse the eyes thoroughly with water, and consult a doctor in case of fuel contact with the eyes.
- Change your clothing in case of fuel spills on them.

### **Note**

**Material damage** Inadequate fuel quality causes the fuel filter to quickly become clogged.

In some countries and regions, the available fuel quality and cleanliness may not be sufficient. This will result in problems with the fuel system.

- Refuel only with clean fuel that meets the specified standards. (Your authorized KTM workshop will be glad to help.)



## Warning

**Environmental hazard** Improper handling of fuel is a danger to the environment.

- Do not allow fuel to enter the groundwater, the soil, or the sewage system.

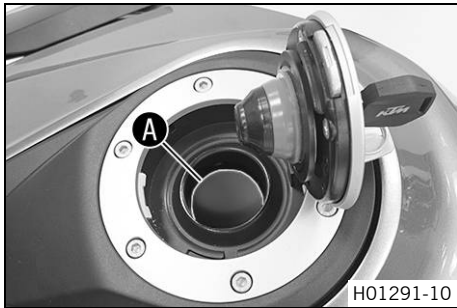

- Switch off the engine.
- Open the filler cap. (📖 p. 38)
- Fill the fuel tank with fuel up to the lower edge **A** of the filler neck.

Total fuel tank capacity, approx.	23 l (6.1 US gal)	Super unleaded (ROZ 95/RON 95/PON 91) (📖 p. 214)
-----------------------------------	-------------------	--













- Close the filler cap. (📖 p. 40)

# 11 SERVICE SCHEDULE

## 11.1 Additional information

Any further work that results from the required work or from the recommended work must be ordered separately and invoiced separately.

## 11.2 Required work

		Every two years				
		Every year				
		every 30,000 km (18,600 mi)				
		every 15,000 km (9,300 mi)				
		after 1,000 km (620 mi)				
Read out the fault memory using the KTM diagnostics tool. 	○	●	●	●	●	●
Check exhaust valve control with the KTM diagnostics tool. 		●	●	●	●	●
Check that the electrical equipment is functioning properly.	○	●	●	●	●	●
Change the engine oil and oil filter and clean the oil screens.   p. 182)	○	●	●	●	●	●
Check the front brake linings.  p. 133)	○	●	●	●	●	●
Check the brake linings of the rear brake.  p. 137)	○	●	●	●	●	●
Check the brake discs.  p. 129)	○	●	●	●	●	●
Check the brake lines for damage and leakage.	○	●	●	●	●	●
Change the front brake fluid. 						●
Change the rear brake fluid. 						●
Change the hydraulic clutch fluid. 						●
Check the front brake fluid level.  p. 130)	○	●	●	●		
Check the rear brake fluid level.  p. 134)	○	●	●	●		
Check/correct the fluid level of the hydraulic clutch.  p. 120)		●	●	●		

# 11 SERVICE SCHEDULE

	Every two years				
	Every year				
	every 30,000 km (18,600 mi)				
	every 15,000 km (9,300 mi)				
	after 1,000 km (620 mi)				
Check the shock absorber and fork for leaks. Perform service as needed and depending on how the vehicle is used. 🛠️	○	●	●	●	●
Clean the dust boots of the fork legs. (📖 p. 126)		●	●		
Check the play of the steering head bearing. 🛠️	○	●	●	●	●
Check the tire condition. (📖 p. 145)	○	●	●	●	●
Check the tire air pressure. (📖 p. 147)	○	●	●	●	●
Check the chain, rear sprocket, engine sprocket, and chain guide. (📖 p. 116)		●	●	●	●
Check the chain tension. (📖 p. 114)	○	●	●	●	●
Measure the wheel bearing backlash and grease the wheel bearing. 🛠️			●		
Check that the rear wheel nut (right side) is tightened to the specified torque. 🛠️	○	●	●	●	●
Change the spark plugs (air filter removed). 🛠️			●		
Check the valve clearance (air filter and spark plugs removed). 🛠️			●		
Change the SAS membrane. 🛠️			●		
Check the cables for damage and routing without sharp bends (fuel tank removed). 🛠️		●	●	●	●
Check the coolant level in the compensating tank. (📖 p. 175)	○	●	●	●	●
Change the air filter, clean the air filter box. 🛠️		●	●		
Check the fuel pressure. 🛠️		●	●	●	●
Check the CO adjustment using the KTM diagnostics tool. 🛠️	○	●	●		
Check the setting of the lighting system. (📖 p. 163)	○	●	●		

	Every two years				
	Every year				
	every 30,000 km (18,600 mi)				
	every 15,000 km (9,300 mi)				
	after 1,000 km (620 mi)				
Check that the radiator fan is functioning properly. 🛠️	○	●	●	●	●
Final check: Check the vehicle for road worthiness and take a test ride. 🛠️	○	●	●	●	●
Read out the error memory after the test ride using the KTM diagnostics tool. 🛠️	○	●	●	●	●
Reset the service display using the KTM diagnostic tool. 🛠️	○	●	●	●	●
Make the service entry in the <b>KTM Dealer.net</b> and in the Service and Warranty Booklet. 🛠️	○	●	●	●	●

- One-time interval
- Periodic interval

## 11.3 Recommended work

	Every four years				
	Every year				
	every 30,000 km (18,600 mi)				
	every 15,000 km (9,300 mi)				
	after 1,000 km (620 mi)				
Check the frame. 🛠️			●		
Check the swingarm. 🛠️			●		
Check/clean the oil nozzle for clutch lubrication. 🛠️	○	●	●		
Check the swingarm bearing. 🛠️		●	●		
Check the wheel bearings. 🛠️		●	●		

# 11 SERVICE SCHEDULE

				Every four years
				Every year
		every 30,000 km (18,600 mi)		
		every 15,000 km (9,300 mi)		
		after 1,000 km (620 mi)		
Grease all moving parts (e.g., side stand, hand lever, chain, ...) and check for smooth operation. 🛠️	○	●	●	●
Empty the drainage hoses. 🛠️	○	●	●	●
Check all hoses (e.g. fuel, cooling, bleeder, drainage, etc.) and sleeves for cracking, leaks, and incorrect routing. 🛠️		●	●	●
Check the screws and nuts for tightness. 🛠️	○	●	●	●
Check the antifreeze. 🛠️	○	●	●	●
Change the coolant. 🛠️				●

- One-time interval
- Periodic interval

## 12.1 Fork/shock absorber

Semi-active suspension **WP Semi-active Suspension** can be used to tune the suspension individually without the use of tools. Electronic suspension setting **WP Semi-active Suspension** constantly regulates the damping behavior of the suspension taking into account various sensor data.

As a result, the electronic damping valves are matched to the current driving situation and terrain characteristics as well as the settings made by the rider in the **"Load"** and **"Damping"** menu.

Always adapt the suspension to your riding style and the payload.

In the **"Load"** menu, the suspension can be set to the payload.

In the **"Damping"** menu, the damping behavior of the suspension can be set.

## 12.2 "Load"

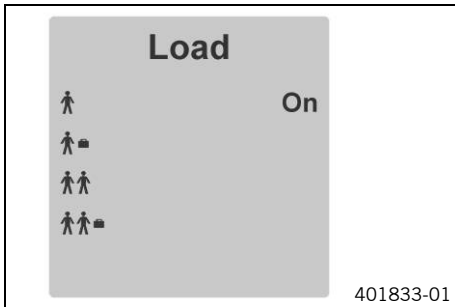

Tunings for different vehicle loading states can be selected in the **"Load"** menu. A selection can be made between one-person operation, one-person operation with luggage, two-person operation, and two-person operation with luggage.

The load mode selected last is displayed on the right in the segment display.



### Info

For the setting to be accepted by the motorcycle, the motorcycle must be stationary and the engine must be running.

The symbol of the last load status flashes until the new setting is adopted.

## 12.3 "Damping"



401831-01

### Possible states

- SPORT – Firm tuning of the spring elements with very direct feedback from the chassis
- STREET – Normal tuning of the spring elements with direct feedback from the chassis
- COMFORT – Soft tuning of the spring elements with good feedback from the chassis

Different tunings for the damping of the spring elements can be selected in the "**Damping**" menu. You can choose from "**SPORT**", "**STREET**", and "**COMFORT**".



## 13.1 Lifting the motorcycle with the rear lifting gear

### Note

**Danger of damage** The parked vehicle can roll away or fall over.

- Park the vehicle on a firm and level surface.

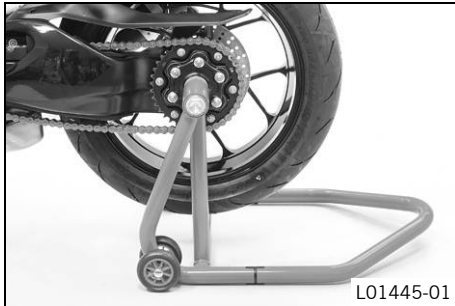

- Place the adapter into the rear lifting gear.

Lifting gear, rear (61329955000)

- Position the motorcycle upright, place the lifting gear in the axle, and raise the motorcycle.

## 13.2 Removing the rear of motorcycle from the lifting gear

### Note

**Danger of damage** The parked vehicle can roll away or fall over.

- Park the vehicle on a firm and level surface.

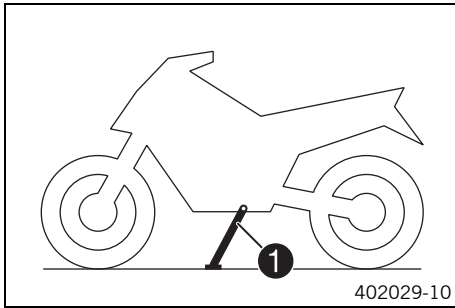

- Secure the motorcycle against falling over.
- Remove the rear wheel stand and lean the vehicle on side stand ①.

## 13.3 Lifting the motorcycle with the front lifting gear

### Note

**Danger of damage** The parked vehicle can roll away or fall over.

- Park the vehicle on a firm and level surface.



### Preparatory work

- Lift the motorcycle with the rear lifting gear. (📖 p. 103)

### Main work

- Move the handlebar to the straight-ahead position.
- Position front lifting gear with adapter.

Adapter (69329965040)
-----------------------

Lifting gear, front (61029055500)
-----------------------------------

- Align the front lifting gear with the fork legs.



### Info

Always raise the motorcycle at the rear first.

- Raise the motorcycle at the front.

## 13.4 Taking the motorcycle from the front lifting gear

### Note

**Danger of damage** The parked vehicle can roll away or fall over.

- Park the vehicle on a firm and level surface.



- Secure the motorcycle against falling over.
- Remove the front lifting gear.

## 13.5 Removing the passenger seat

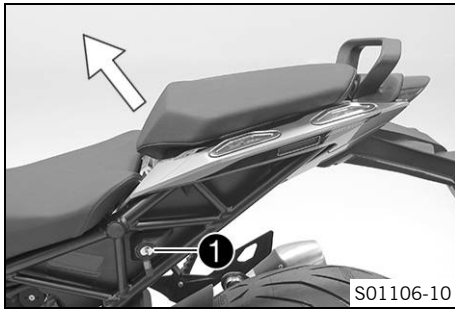

- Insert the ignition key in seat lock **1** and turn it clockwise.
- Raise front of the passenger seat, pull toward the tank, and remove upward.
- Remove the ignition key.

## 13.6 Mounting the passenger seat

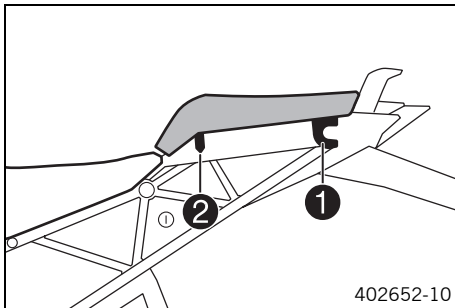

- Attach the hooks on the passenger seat to seat mounts **1**.
- Lower the passenger seat and push back.
- Position locking pin **2** in the lock housing and push down the passenger seat at the front.
  - ✓ The locking pin engages with an audible click.
- Check that the passenger seat is correctly mounted.

## 13.7 Removing the front rider's seat

### Preparatory work

- Remove the passenger seat. (📖 p. 106)

### Main work

- Press seat release ❶ in the direction of the arrow and lift the front rider's seat at the rear at the same time.
- Detach the front of the front rider's seat and remove it.

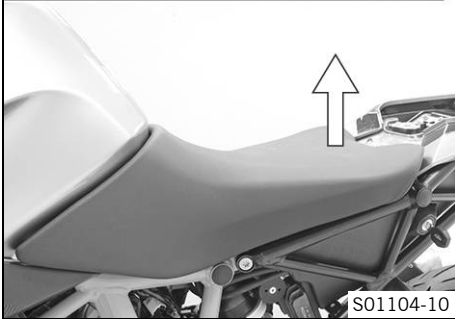
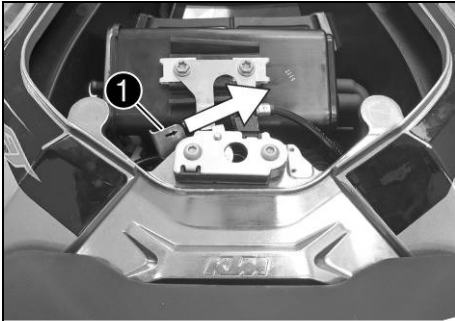

## 13.8 Mounting the front rider's seat

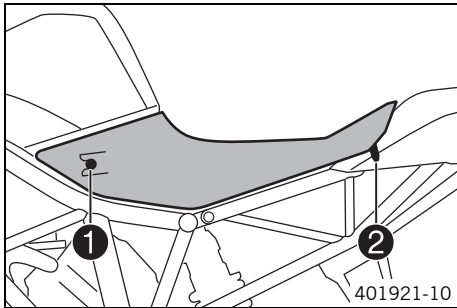

### Main work

- Attach recesses **1** on the front rider's seat to the fuel tank, push the front rider's seat forward.
- Position locking pin **2** in the lock housing and push down the front rider's seat at the rear.
  - ✓ The locking pin engages with an audible click.
- Check that the front rider's seat is correctly mounted.

### Finishing work

- Mount the passenger seat. (🗨️ p. 106)

## 13.9 Removing the windshield

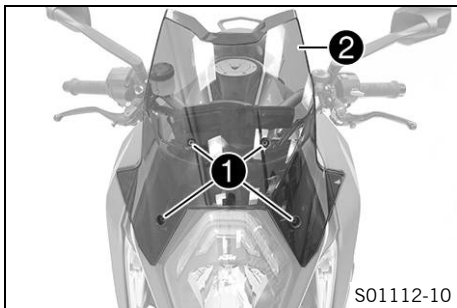

- Remove screws **1** and windshield **2**.

## 13.10 Installing the windshield

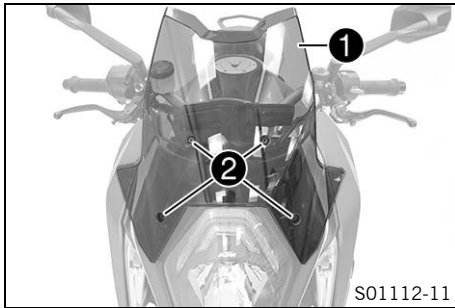

- Position windshield ❶.
- Mount and tighten screws ❷.

Guideline

Screw, windshield	M5	3.5 Nm (2.58 lbf ft)
-------------------	----	-------------------------

## 13.11 Removing the main silencer

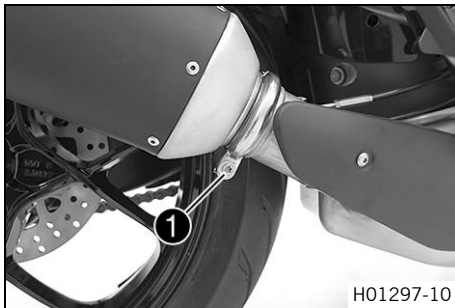

- Remove screw ❶.
- Take off the exhaust clamp.

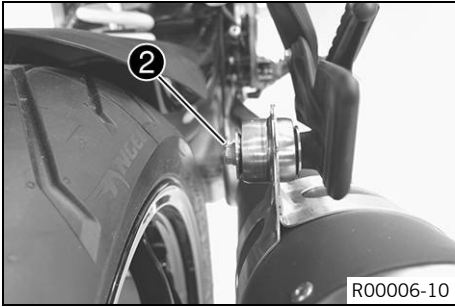

- Remove screw ②.



**Warning**

**Risk of injury** Moving parts of the exhaust valve constitute a risk of injury.

- Do not touch the exhaust valve if the main silencer has been removed.
- Make sure that nobody gets caught when the exhaust valve is actuated.

- Take off the main silencer.

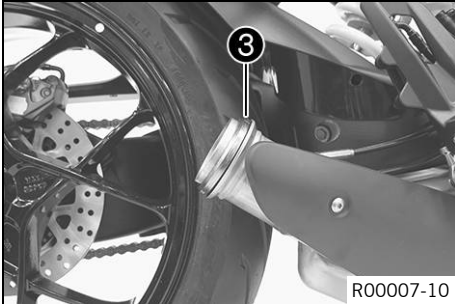

- Remove seal ring ③.



## 13.12 Installing the main silencer ↗

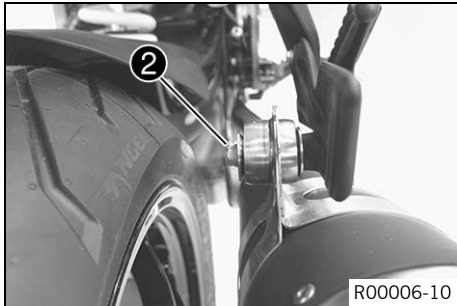
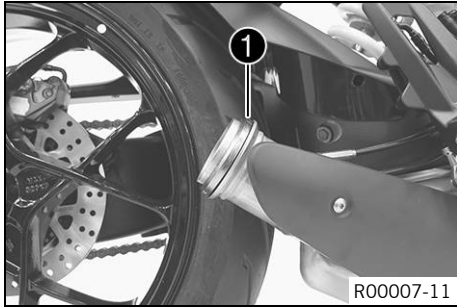

### Warning

**Risk of injury** Moving parts of the exhaust valve constitute a risk of injury.

- Do not touch the exhaust valve if the main silencer has been removed.
- Make sure that nobody gets caught when the exhaust valve is actuated.

- Mount seal ring ①.
- Position the main silencer.
- Mount screw ② but do not tighten yet.

### Guideline

Remaining screws, chassis	M8	25 Nm (18.4 lbf ft)
---------------------------	----	------------------------

# 13 SERVICE WORK ON THE CHASSIS

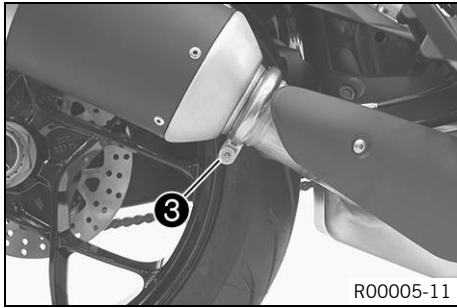

- Position the exhaust clamp.
- Mount and tighten screw ③.

Guideline

Screw, exhaust clamp on main silencer	M6	8 Nm (5.9 lbf ft)
---------------------------------------	----	-------------------

- Tighten screw ②.

Guideline

Remaining screws, chassis	M8	25 Nm (18.4 lbf ft)
---------------------------	----	------------------------

## 13.13 Checking the chain for dirt

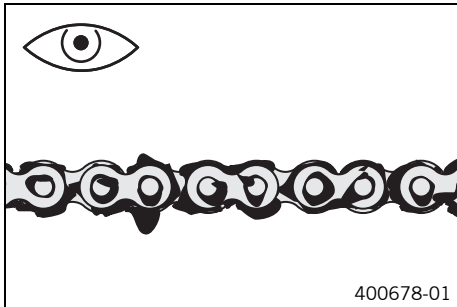

- Check the chain for coarse dirt accumulation.
  - » If the chain is very dirty:
    - Clean the chain. (📖 p. 112)

## 13.14 Cleaning the chain



### Warning

**Danger of accidents** Oil or grease on the tires reduces the road grip.

- Remove the lubricant from the tires using a suitable cleaning agent.



## Warning

**Danger of accidents** Oil or grease on the brake discs reduces the braking effect.

- Always keep the brake discs free of oil and grease.
- Clean the brake discs with brake cleaner when necessary.



## Warning

**Environmental hazard** Hazardous substances cause environmental damage.

- Dispose of oils, grease, filters, fuel, cleaning agents, brake fluid, etc., correctly and in compliance with the applicable regulations.



## Info

The service life of the chain depends largely on its maintenance.

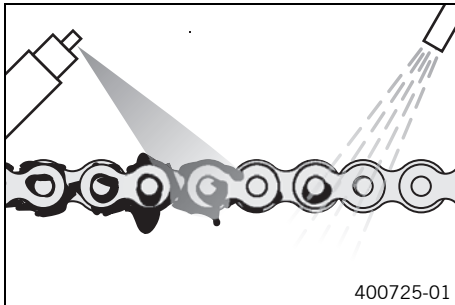

### Preparatory work

- Lift the motorcycle with the rear lifting gear. (📖 p. 103)

### Main work

- Clean the chain regularly.
- Rinse off loose dirt with a soft jet of water.
- Remove old grease residue with chain cleaner.

Chain cleaner (📖 p. 215)

- After drying, apply chain spray.

Chain lube for road use (📖 p. 215)

### Finishing work

- Remove the rear of the motorcycle from the lifting gear. (📖 p. 103)

## 13.15 Checking the chain tension



### Warning

**Danger of accidents** Incorrect chain tension damages components and results in accidents.

If the chain is tensioned too much, the chain, engine sprocket, rear sprocket, transmission and rear wheel bearings wear more quickly. Some components may break if overloaded.

If the chain is too loose, the chain may fall off the engine sprocket or the rear sprocket. As a result, the rear wheel locks or the engine will be damaged.

- Check the chain tension regularly.
- Set the chain tension in accordance with the specification.

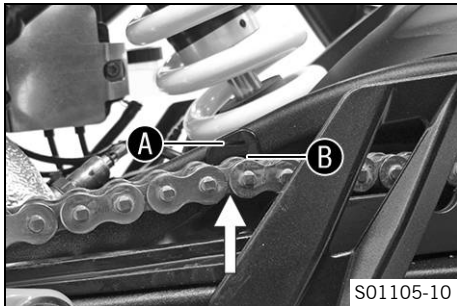

### Preparatory work

- Lift the motorcycle with the rear lifting gear. (📖 p. 103)

### Main work

- Shift the transmission to idle **N**.
- At the chain sliding guard in the area of markings **A** and **B**, push the chain upward and determine the chain tension.



### Info

The lower chain section must be taut.

Chain wear is not always even, so you should repeat this measurement at different chain positions.

The upper edge of the chain is located between markings **A** and **B**.

- » If the chain tension does not meet the specification:
  - Adjust the chain tension. (📖 p. 115)

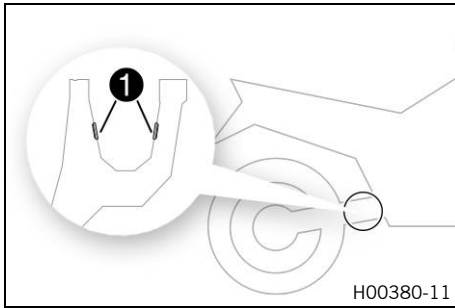

- Check locking caps ❶ for damage and firm seating.

- » If the locking caps are damaged or loose:

- Replace the locking caps.

Link fork locking cap (61304041100)

- Remove the rear of the motorcycle from the lifting gear. (📖 p. 103)

## 13.16 Adjusting the chain tension



### Warning

**Danger of accidents** Incorrect chain tension damages components and results in accidents.

If the chain is tensioned too much, the chain, engine sprocket, rear sprocket, transmission and rear wheel bearings wear more quickly. Some components may break if overloaded.

If the chain is too loose, the chain may fall off the engine sprocket or the rear sprocket. As a result, the rear wheel locks or the engine will be damaged.

- Check the chain tension regularly.
- Set the chain tension in accordance with the specification.

### Preparatory work

- Lift the motorcycle with the rear lifting gear. (📖 p. 103)
- Check the chain tension. (📖 p. 114)

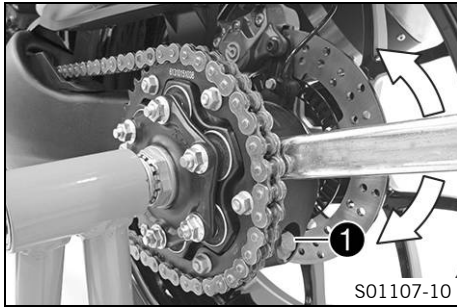

### Main work

- Loosen screw ❶.
- Set the chain tension by turning the hub housing.

Hook wrench (61329085000)
---------------------------

Handle for ring wrench (60012060000)
--------------------------------------

### Info

Turn clockwise to increase the chain tension; turn counterclockwise to reduce the chain tension.

- Check the chain tension. (📖 p. 114)
- ✓ The chain tension matches the specified value.

### Info

Chain wear is not always even, so you should repeat this measurement at different chain positions.

- Tighten screw ❶.

### Guideline

Screw, eccentric	M16	70 Nm (51.6 lbf ft)
------------------	-----	------------------------

- Remove the rear of the motorcycle from the lifting gear. (📖 p. 103)

## 13.17 Checking the chain, rear sprocket, engine sprocket, and chain guide

### Preparatory work

- Lift the motorcycle with the rear lifting gear. (📖 p. 103)

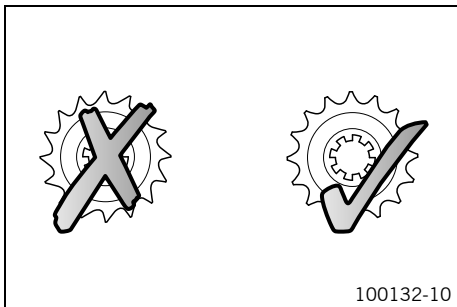

### Main work

- Check the rear sprocket and engine sprocket for wear.
  - » If the rear sprocket or engine sprocket is worn:
    - Change the drivetrain kit. 🛠️



### Info

The engine sprocket, rear sprocket, and chain should always be replaced together.

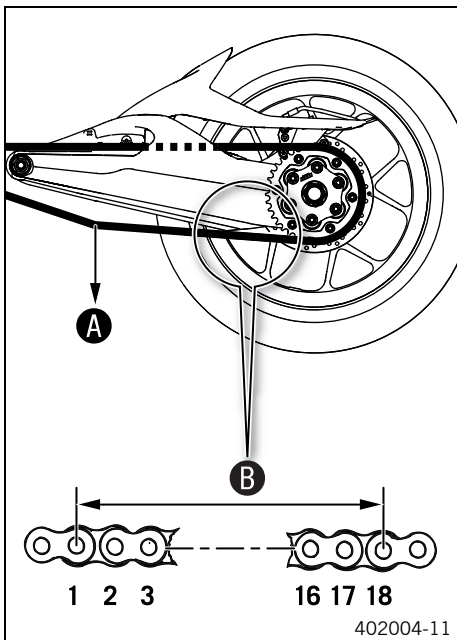

- Shift the transmission to idle **N**.
- Pull the lower chain section with specified weight **A**.

### Guideline

Weight, chain wear measurement	15 kg (33 lb.)
--------------------------------	----------------

- Measure distance **B** of 18 chain rollers in the lower chain section.



### Info

Chain wear is not always even, so you should repeat this measurement at different chain positions.

Maximum distance <b>B</b> at the longest chain section	272 mm (10.71 in)
--	-------------------

- » If distance **B** is greater than the specified measurement:
  - Change the drivetrain kit. 🛠️



## Info

When the chain is replaced, the rear sprocket and engine sprocket should also be changed.

New chains wear out faster on an old, worn rear sprocket or engine sprocket.

For safety reasons, the chain has no chain joint.

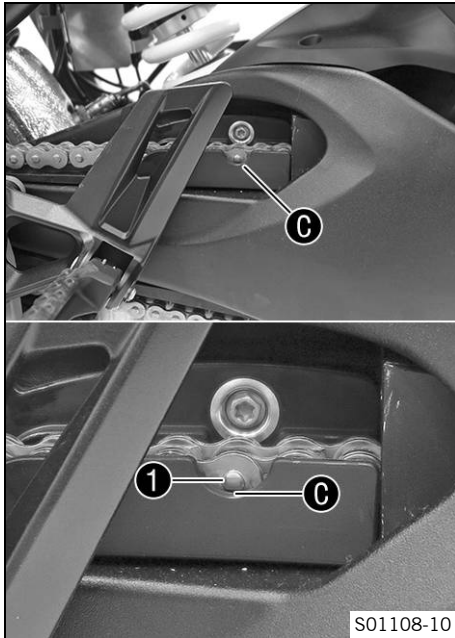

- Check the chain sliding guard for wear at the recess.
  - » If chain rivet **1** is no longer visible at bottom edge **C** of the recess of the chain sliding guard:
    - Change the chain sliding guard. 🛠️
- Check that the chain sliding guard is firmly seated.
  - » If the chain sliding guard is loose:
    - Tighten the screws on the chain sliding guard.

## Guideline

Screw, chain sliding guard	M5	5 Nm (3.7 lbf ft)
----------------------------	----	-------------------



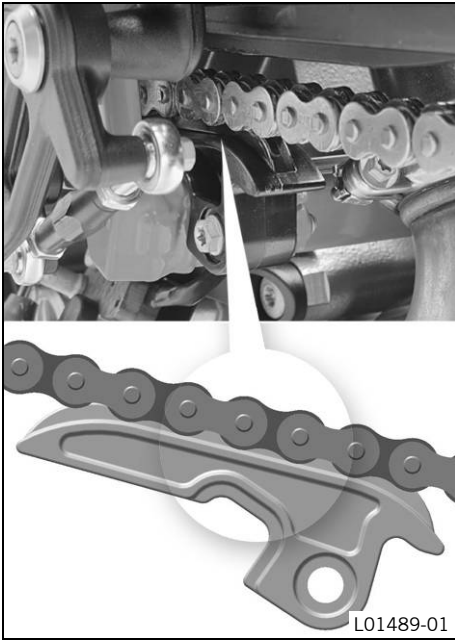

- Check the chain sliding piece for wear.
  - » If the lower edge of the chain is in line with or below the chain sliding piece:
    - Change the chain sliding piece. 🛠️
- Check that the chain sliding piece is firmly seated.
  - » If the chain sliding piece is loose:
    - Tighten the screw on the chain sliding piece.

Guideline

Remaining screws, chassis	M8	25 Nm (18.4 lbf ft)
---------------------------	----	------------------------

**Finishing work**

- Remove the rear of the motorcycle from the lifting gear. (📖 p. 103)

## 13.18 Checking/correcting the fluid level of the hydraulic clutch



### Warning

**Skin irritation** Brake fluid causes skin irritation.

- Keep brake fluid out of the reach of children.
- Wear suitable protective clothing and safety glasses.
- Do not allow brake fluid to come into contact with the skin, the eyes or clothing.
- Consult a doctor immediately if brake fluid has been swallowed.
- Rinse the affected area with plenty of water in the event of contact with the skin.
- Rinse eyes thoroughly with water immediately and consult a doctor if brake fluid comes into contact with the eyes.
- If brake fluid spills on to your clothing, change the clothing.



### Warning

**Environmental hazard** Hazardous substances cause environmental damage.

- Dispose of oils, grease, filters, fuel, cleaning agents, brake fluid, etc., correctly and in compliance with the applicable regulations.



### Info

The fluid level rises with increasing wear of the clutch facing discs.

Never use DOT 5 brake fluid. It is silicone-based and purple in color. Oil seals and clutch lines are not designed for DOT 5 brake fluid.

Avoid contact between brake fluid and painted parts. Brake fluid attacks paint.

Only use clean brake fluid from a sealed container.

- Move the clutch fluid reservoir mounted on the handlebar to a horizontal position.

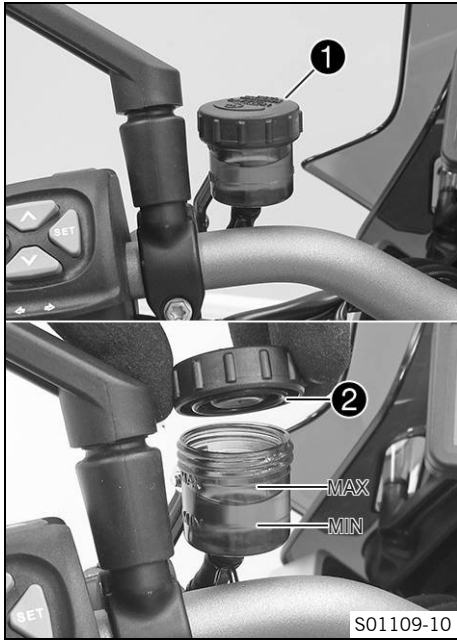

- Check the fluid level.

The fluid level must be between **MIN** and **MAX** markings.

» If the fluid level does not meet specifications:

- Remove screw cap **1** with membrane **2**.
- Correct the fluid level of the hydraulic clutch.

Brake fluid DOT 4 / DOT 5.1 (📖 p. 212)

- Mount and tighten screw cap **1** with membrane **2**.

**i** Info

Clean up overflowed or spilled brake fluid immediately with water.

## 13.19 Removing the tank spoiler

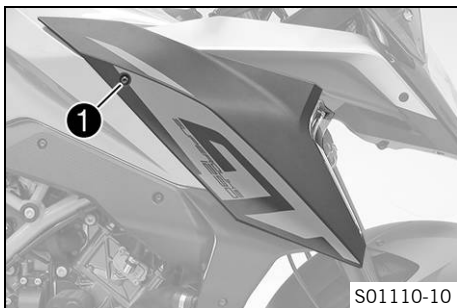

- Remove screw ①.

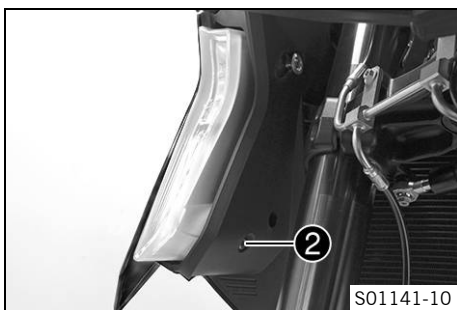

- Remove screw ②.

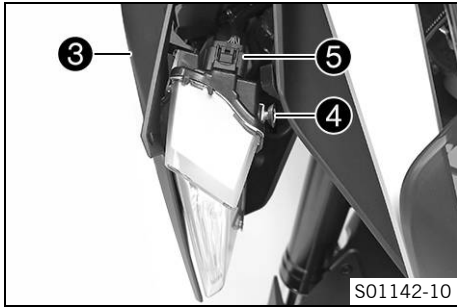

- Pull tank spoiler ③ forward and detach bushing ④.



### Info

Pay attention to the cornering light cable.

- Unplug connector ⑤.
- Remove tank spoiler ③ with cornering light.
- Repeat these steps on the opposite side.

## 13.20 Installing the tank spoiler

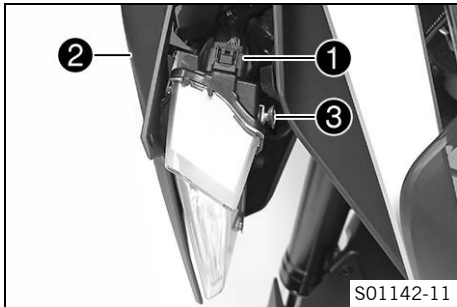

- Plug in connector ①.
- Position tank spoiler ②.
- Attach bushing ③.

# 13 SERVICE WORK ON THE CHASSIS

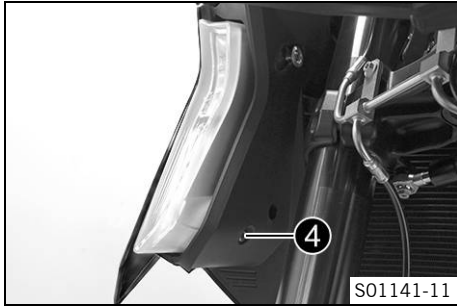

- Mount and tighten screw ④.

Guideline

Screw, cover part	M5	3.5 Nm (2.58 lbf ft)
-------------------	----	-------------------------



- Mount and tighten screw ⑤.

Guideline

Screw, cover part	M5	3.5 Nm (2.58 lbf ft)
-------------------	----	-------------------------

- Repeat these steps on the opposite side.

## 13.21 Removing the front fender

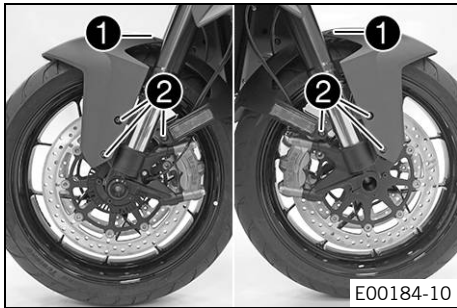

- Remove screws ①.
- Remove screws ②.
- Take off the fender.

**i Info**  
Pay attention to the brake lines.

## 13.22 Installing the front fender ↩

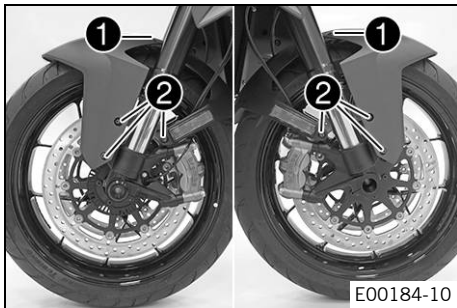

- Position the fender.

**i Info**  
Pay attention to where the brake lines are placed.

- Mount and tighten screws ①.

Guideline

Screw, cover part	M5	3.5 Nm (2.58 lbf ft)
-------------------	----	-------------------------

- Mount and tighten screws ②.

Guideline

Remaining screws, chassis	M5	5 Nm (3.7 lbf ft)
---------------------------	----	-------------------

## 13.23 Cleaning the dust boots of the fork legs

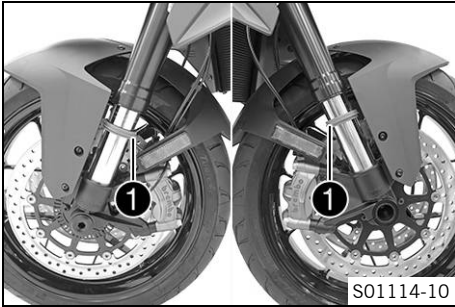

- Push dust boot ① of both fork legs downwards.

### Info

The dust boots should remove dust and coarse dirt particles from the fork tubes. Over time, dirt can penetrate behind the dust boots. If this dirt is not removed, the oil seals behind can start to leak.

### Warning

**Danger of accidents** Oil or grease on the brake discs reduces the braking effect.

- Always keep the brake discs free of oil and grease.
  - Clean the brake discs with brake cleaner when necessary.
- 
- Clean and oil the dust boots and inner fork tube of both fork legs.

Universal oil spray (📖 p. 216)

- Press the dust boots back into their normal position.
- Remove excess oil.



## 14.1 Antilock braking system (ABS)

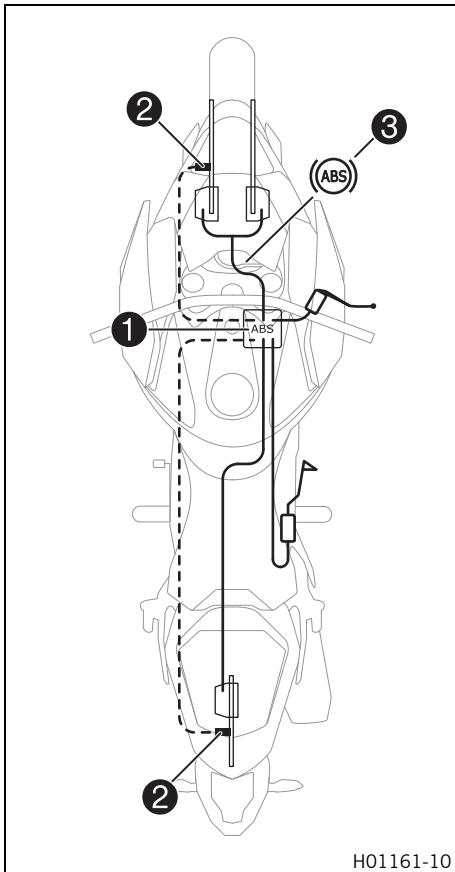

H01161-10

ABS unit **1**, which consists of a hydraulic unit, brake electronics control unit, and return pump, is installed on the right vehicle side below the fuel tank. One wheel speed sensor **2** is located in each case on the front and the rear wheel.



### Warning

**Danger of accidents** Changes to the vehicle impair the function of the ABS.

- Only allow the rear wheel to spin with the front brake applied away from public road traffic if the ABS is switched off.
- Do not make any changes to the suspension travel.
- Only use spare parts on the brake system which have been approved and recommended by KTM.
- Only use tires/wheels approved by KTM with the corresponding speed index.
- Maintain the specified tire air pressure.
- Service work and repairs must be performed professionally. (Your authorized KTM workshop will be glad to help.)



### Warning

**Voiding of the government approval for road use and the insurance coverage** If the ABS is switched off completely, the vehicle's approval for road use is invalidated.

- Only operate the vehicle in closed-off areas remote from public road traffic if the ABS is switched off completely.

ABS is a safety system that prevents locking of the wheels when driving straight ahead without the influence of lateral forces.



## Warning

**Danger of accidents** Vehicle rollover

- It is not always possible to prevent vehicle rollover in extreme riding situations (e. g. luggage loaded with a high center of gravity, varying road surfaces, steep descents, full braking without disengaging the gear). Adapt your riding style to the road conditions and your driving ability.

---

ABS has two operating modes: the **"ROAD"** and **"SUP MOT"** ABS modes.

In the **"ROAD"** ABS mode, the ABS controls both wheels.

In the **"SUP MOT"** ABS mode, the ABS only controls the front wheel. There is no ABS intervention on the rear wheel. ABS lamp  flashes slowly to remind you that the **"SUP MOT"** ABS mode is enabled.



## Info

In the **"SUP MOT"** ABS mode, the rear wheel may block and there is a risk of crashing.

---

The ABS operates with two independent brake circuits (front and rear brakes). When the brake electronics control unit detects a locking tendency in a wheel, ABS begins regulating the brake pressure. The regulating process causes a slight pulsing of the hand and foot brake levers.

ABS lamp  must light up after the ignition is switched on and go out after starting off. If it does not go out after starting off or if it is lit while riding, this indicates a fault in the ABS system. In this case, the ABS is no longer enabled and the wheels may lock during braking. The brake system itself stays functional; only ABS control is not available.

The ABS lamp may also light up if the rotating speeds of the front and rear wheels differ greatly under extreme riding conditions, for example when making "wheelies" or if the rear wheel spins. This causes the ABS to switch off.

To reactivate the ABS, the vehicle must be stopped and the ignition switched off. The ABS is reactivated when the vehicle is switched on again. The ABS lamp goes out when you start off.

## MSC

The **MSC** is a supplementary function for the ABS that can prevent blocking and slipping of the wheels during braking when the vehicle is inclined (riding in curves) within the physical limitations.

By means of the 5D sensor, ABS control is now dependent on the inclination and pitch angle.

ABS control that is dependent on the inclination and pitch angle improves the riding stability and braking effect in all riding situations. The **MSC** also reduces the righting moment during hard braking in curves. This prevents the motorcycle from righting itself from an inclined angle and moving along a larger curve radius. Due to the additional electronic control of the brake force distribution between the two wheels, the braking force is optimally distributed and the motorcycle is additionally stabilized.



### Info

The **MSC** is only active in ABS mode "**Road**".

---

## 14.2 Checking the brake discs



### Warning

**Danger of accidents** Worn-out brake discs reduce the braking effect.

- Make sure that worn-out brake discs are replaced immediately. (Your authorized KTM workshop will be glad to help.)
-

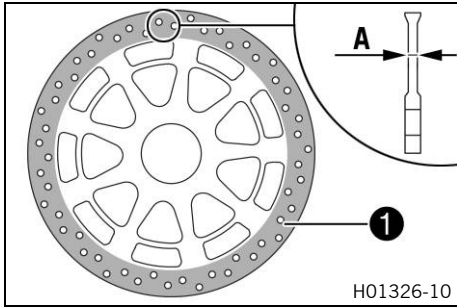

- Check the thickness of the front and rear brake discs at multiple points on each brake disc to ensure it is at least thickness **A**.

**i Info**

Wear will reduce the thickness of the brake disc at contact surface **1** of the brake linings.

Brake discs - wear limit	
Front	4.5 mm (0.177 in)
Brake discs - wear limit	
rear	4.5 mm (0.177 in)

- » If the brake disc thickness is less than the specified value.
  - Change the front brake discs. 🛠️
  - Change the rear brake disc.
- Check the front and rear brake discs for damage, cracking, and deformation.
  - » If the brake disc exhibits damage, cracking, or deformation:
    - Change the front brake discs. 🛠️
    - Change the rear brake disc.

## 14.3 Checking the front brake fluid level



**Warning**

**Danger of accidents** An insufficient brake fluid level will cause the brake system to fail.

If the brake fluid level drops below the **MIN** marking, the brake system is leaking or the brake linings are worn down.

- Check the brake system and do not continue riding until the problem is eliminated. (Your authorized KTM workshop will be glad to help.)



## Warning

**Danger of accidents** Old brake fluid reduces the braking effect.

- Make sure that brake fluid for the front and rear brake is changed in accordance with the service schedule. (Your authorized KTM workshop will be glad to help.)

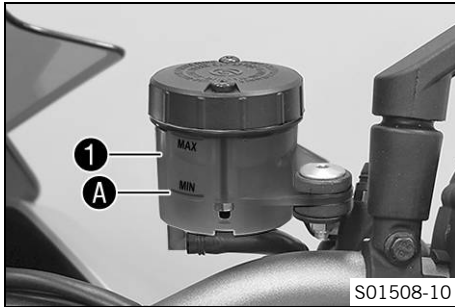

- Move the brake fluid reservoir mounted on the handlebar to a horizontal position.
- Check the brake fluid level in brake fluid reservoir ①.
  - » If the brake fluid has dropped below **MIN** marking ②:
    - Add front brake fluid. 🛠️ (📖 p. 131)

## 14.4 Adding front brake fluid 🛠️



## Warning

**Danger of accidents** An insufficient brake fluid level will cause the brake system to fail.

If the brake fluid level drops below the **MIN** marking, the brake system is leaking or the brake linings are worn down.

- Check the brake system and do not continue riding until the problem is eliminated. (Your authorized KTM workshop will be glad to help.)



## Warning

**Skin irritation** Brake fluid causes skin irritation.

- Keep brake fluid out of the reach of children.
- Wear suitable protective clothing and safety glasses.
- Do not allow brake fluid to come into contact with the skin, the eyes or clothing.
- Consult a doctor immediately if brake fluid has been swallowed.
- Rinse the affected area with plenty of water in the event of contact with the skin.
- Rinse eyes thoroughly with water immediately and consult a doctor if brake fluid comes into contact with the eyes.
- If brake fluid spills on to your clothing, change the clothing.



## Warning

**Danger of accidents** Old brake fluid reduces the braking effect.

- Make sure that brake fluid for the front and rear brake is changed in accordance with the service schedule. (Your authorized KTM workshop will be glad to help.)



## Warning

**Environmental hazard** Hazardous substances cause environmental damage.

- Dispose of oils, grease, filters, fuel, cleaning agents, brake fluid, etc., correctly and in compliance with the applicable regulations.



## Info

Never use DOT 5 brake fluid. It is silicone-based and purple in color. Oil seals and brake lines are not designed for DOT 5 brake fluid.

Avoid contact between brake fluid and painted parts. Brake fluid attacks paint.

Only use clean brake fluid from a sealed container.

---

## Preparatory work

- Check the front brake linings. (📖 p. 133)

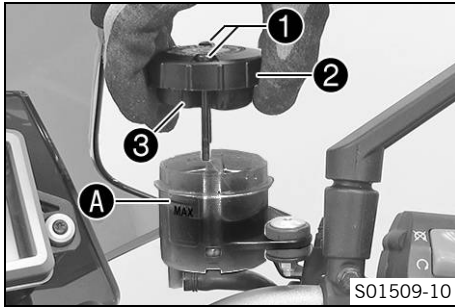

## Main work

- Move the brake fluid reservoir mounted on the handlebar to a horizontal position.
- Remove screws ①.
- Remove cover ② with membrane ③.
- Add brake fluid up to **MAX** marking ④.

Brake fluid DOT 4 / DOT 5.1 (📖 p. 212)

- Position cover ② with membrane ③.
- Mount and tighten screws ①.

## Info

Clean up overflowed or spilled brake fluid immediately with water.

## 14.5 Checking the front brake linings



### Warning

**Danger of accidents** Worn-out brake linings reduce the braking effect.

- Ensure that worn-out brake linings are replaced immediately. (Your authorized KTM workshop will be glad to help.)



### Warning

**Danger of accidents** Damaged brake discs reduce the braking effect.

If the brake linings are not changed in time, the brake lining carriers grind against the brake disc. As a consequence, the braking effect is greatly reduced and the brake discs are destroyed.

- Check the brake linings regularly.

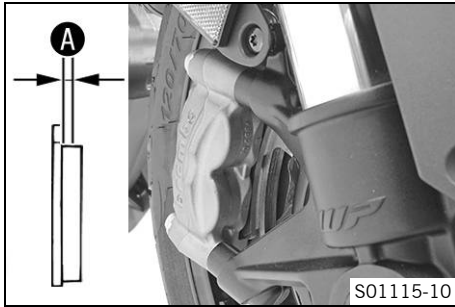

- Check all brake linings on both brake calipers to ensure they have minimum thickness **A**.

Minimum thickness	$\geq 1 \text{ mm } (\geq 0.04 \text{ in})$
-------------------	---

- » If the minimum thickness is less than specified:
  - Change the front brake linings. 🛠️
- Check all brake linings on both brake calipers for damage and cracking.
  - » If there is damage or cracking:
    - Change the front brake linings. 🛠️

## 14.6 Checking the rear brake fluid level



### Warning

**Danger of accidents** An insufficient brake fluid level will cause the brake system to fail.

If the brake fluid level drops below the **MIN** marking, the brake system is leaking or the brake linings are worn down.

- Check the brake system and do not continue riding until the problem is eliminated. (Your authorized KTM workshop will be glad to help.)



### Warning

**Danger of accidents** Old brake fluid reduces the braking effect.

- Make sure that brake fluid for the front and rear brake is changed in accordance with the service schedule. (Your authorized KTM workshop will be glad to help.)



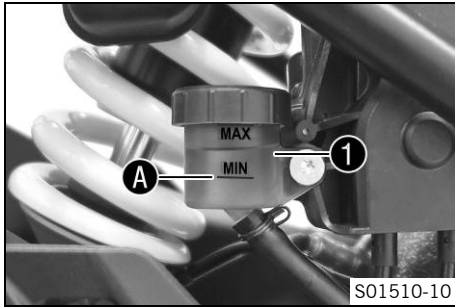

- Stand the vehicle upright.
- Check the brake fluid level in brake fluid reservoir ①.
  - » If the fluid level reaches **MIN** marking **A**:
    - Add rear brake fluid. 🛠️ (📖 p. 135)

## 14.7 Adding rear brake fluid 🛠️



### Warning

**Danger of accidents** An insufficient brake fluid level will cause the brake system to fail.

If the brake fluid level drops below the **MIN** marking, the brake system is leaking or the brake linings are worn down.

- Check the brake system and do not continue riding until the problem is eliminated. (Your authorized KTM workshop will be glad to help.)



### Warning

**Skin irritation** Brake fluid causes skin irritation.

- Keep brake fluid out of the reach of children.
- Wear suitable protective clothing and safety glasses.
- Do not allow brake fluid to come into contact with the skin, the eyes or clothing.
- Consult a doctor immediately if brake fluid has been swallowed.
- Rinse the affected area with plenty of water in the event of contact with the skin.
- Rinse eyes thoroughly with water immediately and consult a doctor if brake fluid comes into contact with the eyes.
- If brake fluid spills on to your clothing, change the clothing.



## Warning

**Danger of accidents** Old brake fluid reduces the braking effect.

- Make sure that brake fluid for the front and rear brake is changed in accordance with the service schedule. (Your authorized KTM workshop will be glad to help.)



## Warning

**Environmental hazard** Hazardous substances cause environmental damage.

- Dispose of oils, grease, filters, fuel, cleaning agents, brake fluid, etc., correctly and in compliance with the applicable regulations.



## Info

Never use DOT 5 brake fluid. It is silicone-based and purple in color. Oil seals and brake lines are not designed for DOT 5 brake fluid.

Avoid contact between brake fluid and painted parts. Brake fluid attacks paint.

Only use clean brake fluid from a sealed container.

## Preparatory work

- Check the brake linings of the rear brake. (📖 p. 137)

## Main work

- Stand the vehicle upright.
- Remove screw cap **1** with membrane **2**.
- Add brake fluid up to **MAX** marking **A**.

Brake fluid DOT 4 / DOT 5.1 (📖 p. 212)

- Mount and tighten screw cap **1** with membrane **2**.



## Info

Clean up overflowed or spilled brake fluid immediately with water.

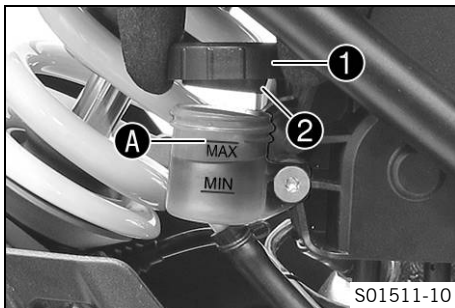

## 14.8 Checking the brake linings of the rear brake



### Warning

**Danger of accidents** Worn-out brake linings reduce the braking effect.

- Ensure that worn-out brake linings are replaced immediately. (Your authorized KTM workshop will be glad to help.)



### Warning

**Danger of accidents** Damaged brake discs reduce the braking effect.

If the brake linings are not changed in time, the brake lining carriers grind against the brake disc. As a consequence, the braking effect is greatly reduced and the brake discs are destroyed.

- Check the brake linings regularly.

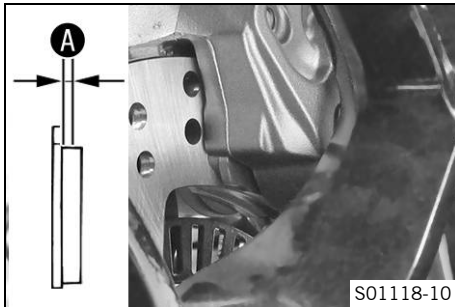

- Check the brake linings for minimum thickness **A**.

Minimum thickness <b>A</b>	$\geq 1 \text{ mm } (\geq 0.04 \text{ in})$
----------------------------	---

- » If the minimum thickness is less than specified:
  - Change the rear brake linings. 🛠️
- Check the brake linings for damage and cracking.
  - » If there is damage or cracking:
    - Change the rear brake linings. 🛠️

## 15.1 Removing the front wheel ↩

### Preparatory work

- Lift the motorcycle with the rear lifting gear. (📖 p. 103)
- Lift the motorcycle with the front lifting gear. (📖 p. 104)

### Main work

- Remove screw ❶ and pull wheel speed sensor ❷ out of the hole.

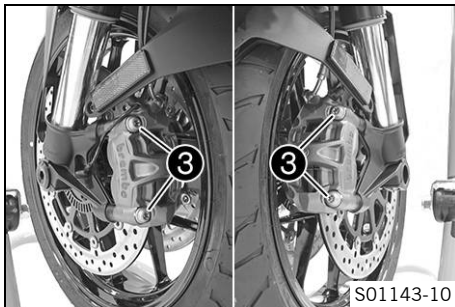
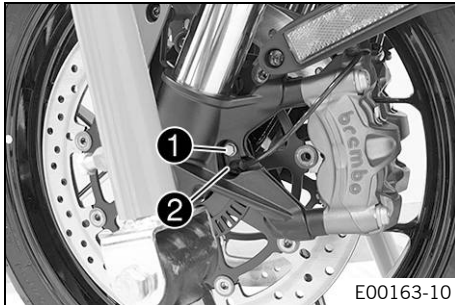

- Remove screws ❸ from both brake calipers.
- Press back the brake linings with a slight lateral tilting of the brake calipers on the brake disc. Pull the brake calipers carefully back from the brake discs and hang them to one side.



### Info

Do not pull the hand brake lever when the brake caliper has been removed.

# 15 WHEELS, TIRES

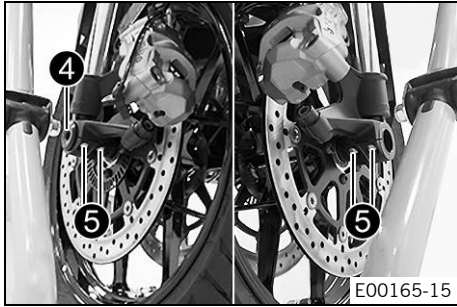

- Loosen screw 4 and screws 5.
- Unscrew screw 4 about six turns and press your hand on the screw to push the wheel spindle out of the axle clamp. Remove screw 4.



### Warning

**Danger of accidents** Damaged brake discs reduce the braking effect.

- Always lay the wheel down in such a way that the brake discs are not damaged.

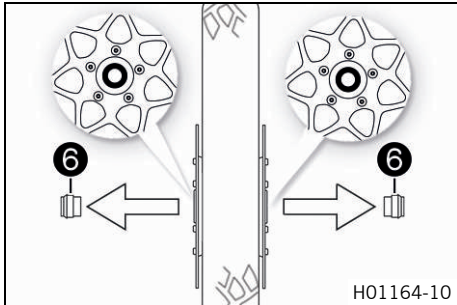

- Holding the front wheel, withdraw the wheel spindle. Take the front wheel out of the fork.
- Remove spacers 6.

## 15.2 Installing the front wheel ↗

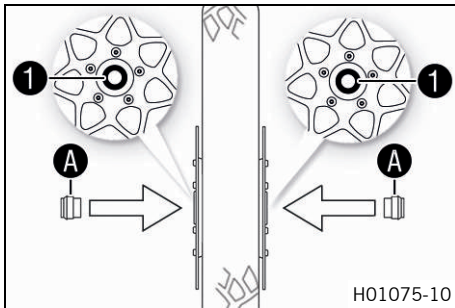

- Check the wheel bearing for damage and wear.
  - » If the wheel bearing is damaged or worn:
    - Change the front wheel bearing. ↗
- Clean and grease shaft seal rings ① and mating surfaces ① of the spacers.

Long-life grease (📖 p. 215)

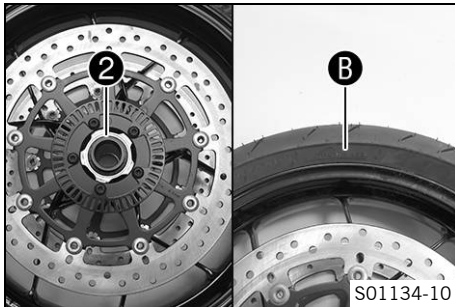

- Insert wide spacer ② on the left in the direction of travel.

### **i** Info

Arrow ② indicates the direction of travel of the front wheel.  
The ABS sensor wheel is on the left-hand side when looking in the direction of travel.

- Insert the narrow spacer on the right in the direction of travel.

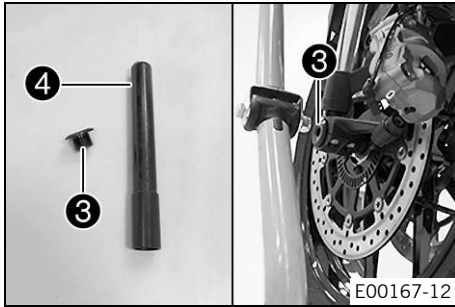

**Warning**

**Danger of accidents** Oil or grease on the brake discs reduces the braking effect.

- Always keep the brake discs free of oil and grease.
- Clean the brake discs with brake cleaner when necessary.

- Clean screw ③ and wheel spindle ④.
- Lift the front wheel into the fork, position it, and insert the wheel spindle.
- Mount and tighten screw ③.

Guideline

Bolt, front axle	M25x1.5	45 Nm (33.2 lbf ft)	Thread greased
------------------	---------	------------------------	----------------

- Position the brake calipers and check that the brake linings are seated correctly.
- Mount screws ⑤ on both brake calipers but do not tighten yet.
- Operate the hand brake lever repeatedly until the brake linings are in contact with the brake disc and there is a pressure point. Fix the hand brake lever in the activated position.
- ✓ The brake calipers straighten.
- Tighten screws ⑤ on both brake calipers.

Guideline

Screw, front brake caliper	M10	45 Nm (33.2 lbf ft)	Loctite® 243™
----------------------------	-----	------------------------	---------------

- Remove the fixation of the hand brake lever.

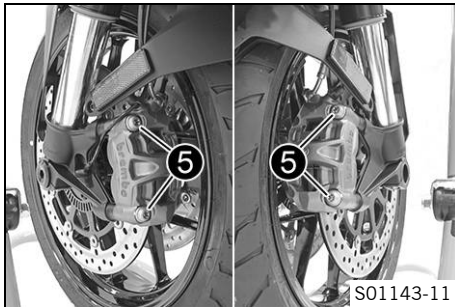

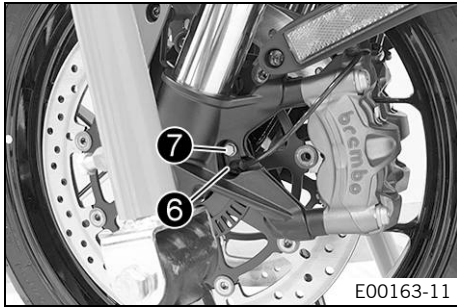

- Position wheel speed sensor ⑥ in the drill hole.
- Mount and tighten screw ⑦.

Guideline

Screw, wheel speed sensor, front	M6	4 Nm (3 lbf ft)
----------------------------------	----	-----------------

- Take the motorcycle from the front lifting gear. (📖 p. 105)
- Remove the rear of the motorcycle from the lifting gear. (📖 p. 103)

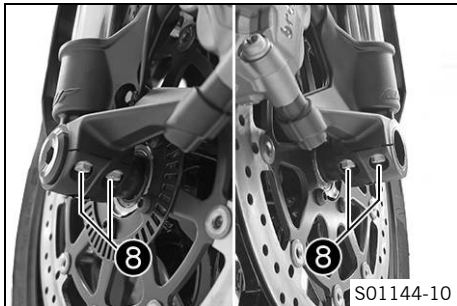

- Operate the front brake and compress the fork a few times firmly.  
✓ The fork legs straighten.
- Tighten screws ⑧.

Guideline

Screw, axle clamp	M8	15 Nm (11.1 lbf ft)
-------------------	----	------------------------

## 15.3 Removing the rear wheel 🛠️

### Preparatory work

- Lift the motorcycle with the rear lifting gear. (📖 p. 103)
- Remove the main silencer. 🛠️ (📖 p. 109)



# 15 WHEELS, TIRES

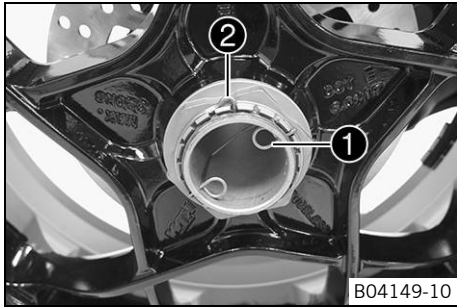

### Main work

- Remove the inside locking wire ①.
- Remove the outside locking wire ②.

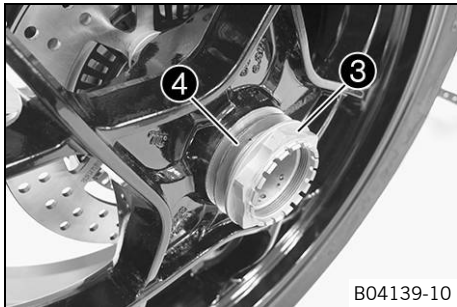

- Have an assistant operate the rear brake.
- Loosen nut ③ and remove it with washer ④.



- Take off the rear wheel.

## 15.4 Installing the rear wheel 🛠️



### Warning

**Danger of accidents** Oil or grease on the brake discs reduces the braking effect.

- Always keep the brake discs free of oil and grease.
- Clean the brake discs with brake cleaner when necessary.



### Main work

- Check the rear wheel bearing for damage and wear.
  - » If the rear wheel bearing is damaged or worn:
    - Change the rear wheel bearing. 🛠️
- Clean and grease the threads of the wheel axle and axle nut.

Long-life grease (📖 p. 215)

- Slide the rear wheel onto the axle.
  - ✓ Driving pins ① engage in drilled holes Ⓐ of the rim.

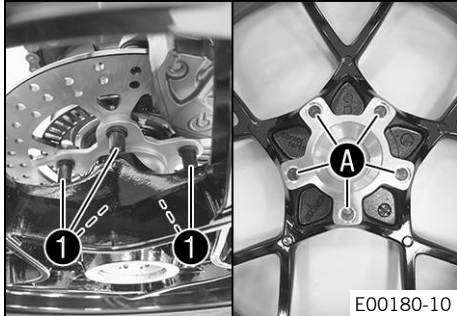

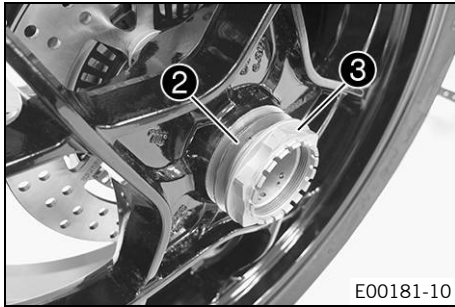

- Mount washer ② and nut ③.
- Have an assistant operate the rear brake.
- Tighten nut ③.

Guideline

Nut, rear axle	M50x1.5	250 Nm (184.4 lbf ft)	Thread greased/lock locking wire with locking varnish
----------------	---------	--------------------------	--

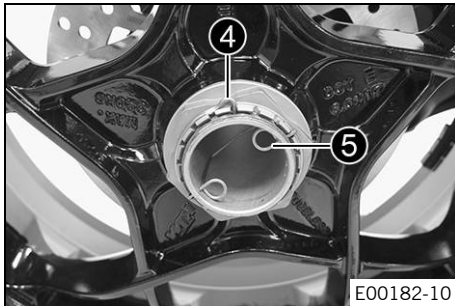

- Mount outside locking wire ④.
- Mount inside locking wire ⑤.
- ✓ The pins of the locking wires engage in the drilled holes of the wheel axle.

**Finishing work**

- Remove the rear of the motorcycle from the lifting gear. (📖 p. 103)
- Install the main silencer. 🛠️ (📖 p. 111)

## 15.5 Checking the tire condition

- Warning**  
**Danger of accidents** If a tire bursts while riding, the vehicle becomes uncontrollable.
- Ensure that damaged or worn tires are replaced immediately. (Your authorized KTM workshop will be glad to help.)

 **Warning**  
**Danger of crashing** Different tire tread patterns on the front and rear wheel impair the handling characteristic. Different tire tread patterns can make the vehicle significantly more difficult to control.

- Make sure that only tires with a similar tire tread pattern are fitted to the front and rear wheel.

 **Warning**  
**Danger of accidents** Non-approved or non-recommended tires and wheels impact the handling characteristic.

- Only use tires/wheels approved by KTM with the corresponding speed index.

 **Warning**  
**Danger of accidents** Reduced road grip with new tires.

- New tires have a smooth rolling surface and therefore cannot provide full road grip. The entire rolling surface must be roughened in the first 200 kilometers (124.3 miles) by moderate riding at alternating angles. The full grip levels are not achieved until the tires have been run in.
- 

 **Info**  
Tire type, tire condition, and tire air pressure influence the braking and handling characteristics of the vehicle. Worn tires are particularly unfavorable on wet surfaces.

---

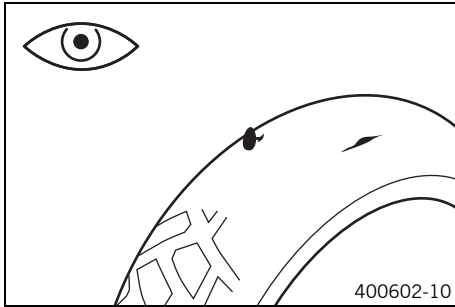

- Check the front and rear tires for cuts, run-in objects, and other damage.
  - » If the tires have cuts, run-in objects, or other damage:
    - Change the tires.
- Check the tread depth.



### Info

Adhere to the legally required minimum tread depth.

Minimum tread depth	$\geq 2 \text{ mm } (\geq 0.08 \text{ in})$
---------------------	---

- » If the tread depth is less than the minimum tread depth:
  - Change the tires.
- Check the tire age.



### Info

The tire date of manufacture is usually contained in the tire label and is indicated by the last four digits of the **DOT** number. The first two digits indicate the week of manufacture and the last two digits the year of manufacture. KTM recommends that the tires be changed after 5 years at the latest, regardless of the actual state of wear.

- » If the tires are more than 5 years old:
  - Change the tires.

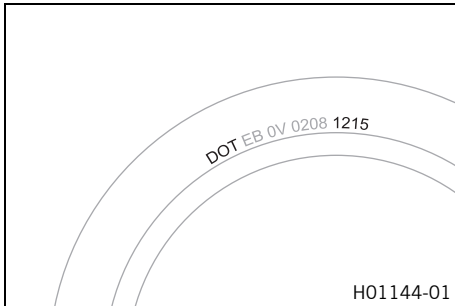

## 15.6 Checking the tire air pressure



### Info

Low tire air pressure leads to abnormal wear and overheating of the tire. Correct tire air pressure ensures optimal riding comfort and maximum tire service life.

# 15 WHEELS, TIRES

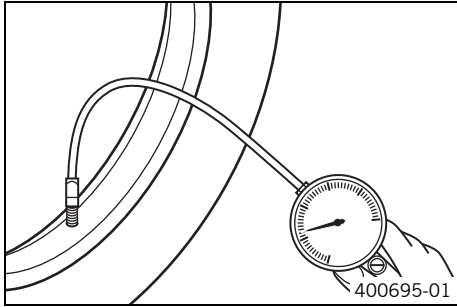

- Remove the dust cap.
- Check the tire air pressure when the tires are cold.

Tire air pressure, solo/with passenger/full payload	
Front: with cold tires	2.5 bar (36 psi)
Rear: with cold tires	2.9 bar (42 psi)

- » If the tire pressure does not meet specifications:
  - Correct the tire pressure.
- Mount the dust cap.

## 16.1 Daytime running light (DRL)

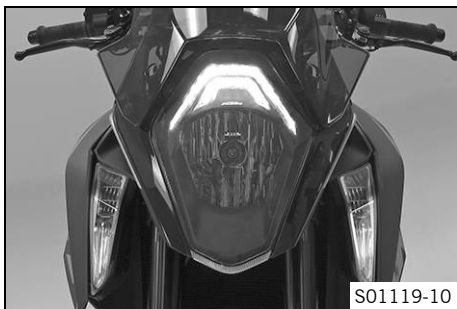

The daytime running light/parking light is integrated in the main headlight. The daytime running light can be switched on when visibility conditions are good. Activate the daytime running light in the combination instrument. Control is provided by the brightness sensor in the combination instrument. When visibility conditions are good, the low beam is switched off and the daytime running light is switched on. It is four times brighter than the parking light. When the daytime running light is switched off, it serves as a parking light.



### Info

Note the legal regulations regarding the daytime running light.

## 16.2 Cornering headlight

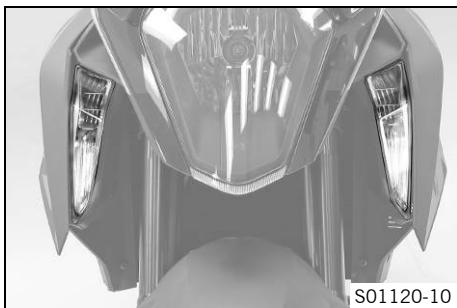

The cornering headlight is located on the left and the right in the tank spoiler.



### Info

To activate the cornering light, the low beam must be switched off and the daytime running light switched on.

The cornering headlights are activated with:

Lean angle for the lower LED	$\geq 12^\circ$
Lean angle for the middle LED	$\geq 20^\circ$
Lean angle for the upper LED	$\geq 28^\circ$
Speed	$\geq 6 \text{ km/h}$ ( $\geq 3.7 \text{ mph}$ )

## 16.3 Removing the battery ↴



### Warning

**Risk of injury** Battery acid and battery gases cause serious chemical burns.

- Keep batteries out of the reach of children.
- Wear suitable protective clothing and goggles.
- Avoid contact with battery acid and battery gases.
- Keep sparks and open flames away from the battery. Only charge in well-ventilated rooms.
- In the event of skin contact, rinse with large amounts of water. If battery acid gets in the eyes, rinse with water for at least 15 minutes and contact a physician.



### Caution

**Danger of accidents** If the vehicle is operated with a discharged battery or without a battery, electronic components and safety equipment may be damaged.

- Never operate the vehicle with a discharged battery or without a battery.

---

### Preparatory work

- Switch off the ignition by turning the black ignition key to the position **OFF** ☒.
- Remove the passenger seat. (📖 p. 106)
- Remove the front rider's seat. (📖 p. 107)



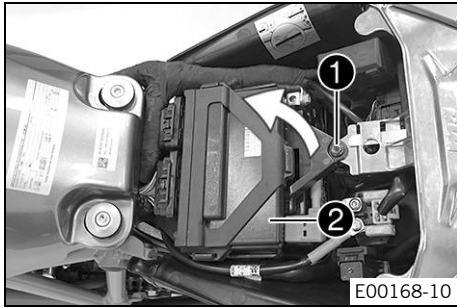

### Main work

- Remove screw ①.
- Lift cover ② at the rear and pull toward the rear.
- Fold up the cover.

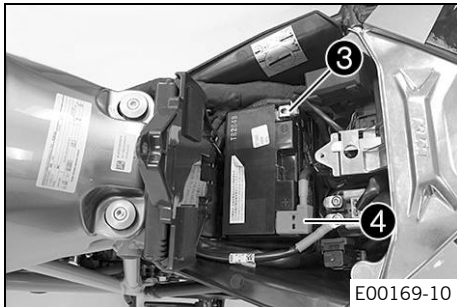

- Disconnect negative cable ③ from the battery.

---

### **i** Info

To prevent damage to the onboard electronics, first disconnect the negative cable from the battery.

---

- Remove positive terminal cover ④ and disconnect the positive cable from the battery.
- Take the battery out of the battery compartment.

## 16.4 Installing the battery ↱



### Warning

**Risk of injury** Battery acid and battery gases cause serious chemical burns.

- Keep batteries out of the reach of children.
- Wear suitable protective clothing and goggles.
- Avoid contact with battery acid and battery gases.
- Keep sparks and open flames away from the battery. Only charge in well-ventilated rooms.
- In the event of skin contact, rinse with large amounts of water. If battery acid gets in the eyes, rinse with water for at least 15 minutes and contact a physician.



### Caution

**Danger of accidents** If the vehicle is operated with a discharged battery or without a battery, electronic components and safety equipment may be damaged.

- Never operate the vehicle with a discharged battery or without a battery.

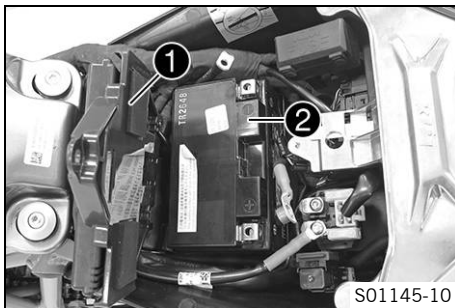

### Main work

- Fold up cover ①.
- Place battery ② in the battery compartment.

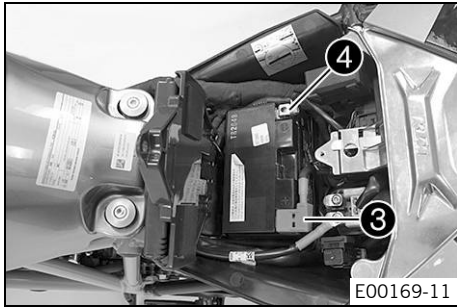

- Position the positive cable and mount and tighten the screw.

Guideline

Screw, battery terminal	M6	4.5 Nm (3.32 lbf ft)
-------------------------	----	-------------------------



**Info**

To prevent damage to the onboard electronics, first connect the positive cable to the battery.

- Mount positive terminal cover **3**.
- Position negative cable **4**; mount and tighten the screw.

Guideline

Screw, battery terminal	M6	4.5 Nm (3.32 lbf ft)
-------------------------	----	-------------------------

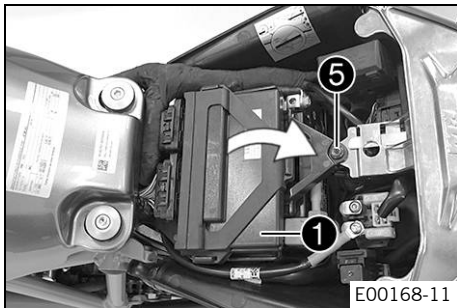

- Fold down cover **1**.
- Mount and tighten screw **5**.

Guideline

Remaining screws, chassis	M5	5 Nm (3.7 lbf ft)
---------------------------	----	-------------------

**Finishing work**

- Mount the front rider's seat. (📖 p. 108)
- Mount the passenger seat. (📖 p. 106)
- Set the time and date.

## 16.5 Recharging the battery ↩



### Warning

**Risk of injury** Battery acid and battery gases cause serious chemical burns.

- Keep batteries out of the reach of children.
- Wear suitable protective clothing and goggles.
- Avoid contact with battery acid and battery gases.
- Keep sparks and open flames away from the battery. Only charge in well-ventilated rooms.
- In the event of skin contact, rinse with large amounts of water. If battery acid gets in the eyes, rinse with water for at least 15 minutes and contact a physician.



### Warning

**Environmental hazard** Batteries contain environmentally-hazardous materials.

- Do not dispose of batteries as household waste.
- Dispose of batteries at a collection point for used batteries.



### Warning

**Environmental hazard** Hazardous substances cause environmental damage.

- Dispose of oils, grease, filters, fuel, cleaning agents, brake fluid, etc., correctly and in compliance with the applicable regulations.
-

## **i** Info

Even when there is no load on the battery, it discharges steadily.

The charge state and the type of charge are very important for the service life of the battery.

Rapid recharging with a high charging current shortens the service life of the battery.

If the charging current, charging voltage, and charging time are exceeded, electrolyte escapes through the safety valves. This reduces the battery capacity.

If the battery is depleted from starting the vehicle repeatedly, the battery must be charged immediately.

If the battery is left in a discharged state for an extended period, over-discharge and sulfating occurs, destroying the battery.

The battery is maintenance-free, i.e., the acid level does not have to be checked.

If the battery is not charged using the KTM battery charger, the battery must be removed for charging. Otherwise, overvoltage may damage electronic components. Charge the battery according to the instructions on the battery housing.

### **Preparatory work**

- Switch off the ignition by turning the black ignition key to the position **OFF** ☒.
- Remove the passenger seat. (📖 p. 106)
- Remove the front rider's seat. (📖 p. 107)

### **Main work**

- Remove screw ①.
- Lift cover ② at the rear and pull toward the rear.
- Fold up the cover.

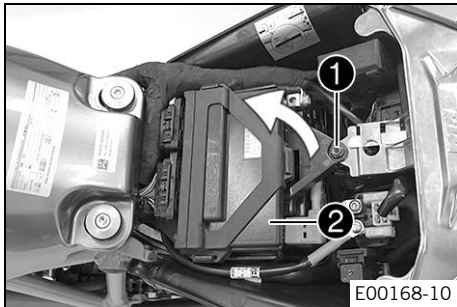

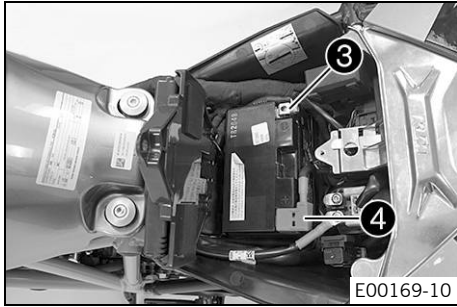

E00169-10

- Disconnect negative cable **3** from the battery.



**Info**

If the negative cable remains connected to the battery, damage to the onboard electronics is possible.

- Remove positive terminal cover **4**.

- Connect the battery charger to the battery.

Battery charger (58429074000)

You can also use the battery charger to test the open-circuit voltage and start potential of the battery, and to test the alternator. With this device, you cannot overcharge the battery.



**Info**

Charge the battery at no more than 10% of the capacity specified on the battery housing.

- Switch on the battery charger.

Guideline

The charging current, charging voltage, and charging time must not be exceeded.	
Charge the battery regularly when the motorcycle is not in use	3 months

- Switch off the battery charger after charging and disconnect from the battery.

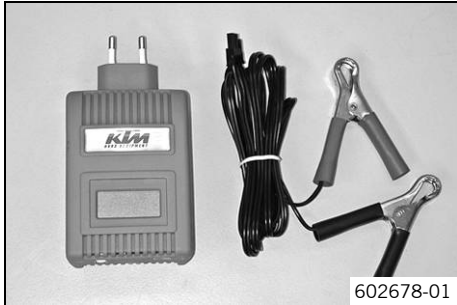

602678-01

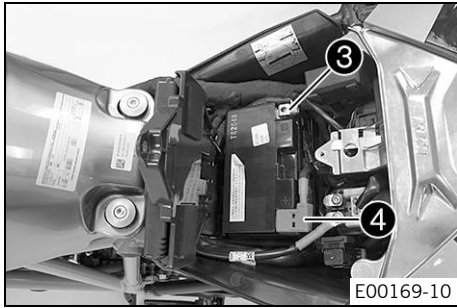

- Mount positive terminal cover ④.
- Position negative cable ③; mount and tighten the screw.

Guideline

Screw, battery terminal	M6	4.5 Nm (3.32 lbf ft)
-------------------------	----	-------------------------

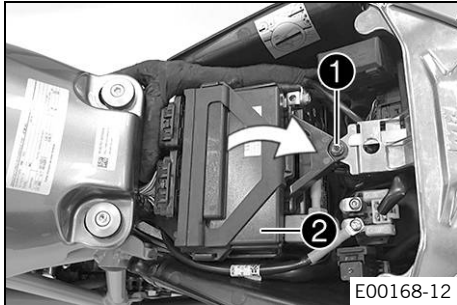

- Fold down cover ②.
- Mount and tighten screw ①.

Guideline

Remaining screws, chassis	M5	5 Nm (3.7 lbf ft)
---------------------------	----	-------------------

### Finishing work

- Mount the front rider's seat. (📖 p. 108)
- Mount the passenger seat. (📖 p. 106)
- Set the time and date.

## 16.6 Changing the main fuse



### Warning

**Fire hazard** Incorrect fuses overload the electrical system.

- Only use fuses with the required ampere value.
- Do not bypass or repair fuses.

### Preparatory work

- Switch off the ignition by turning the black ignition key to the position **OFF** ☒.
- Remove the passenger seat. (📖 p. 106)
- Remove the front rider's seat. (📖 p. 107)

### Main work

- Take off protection caps ❶.

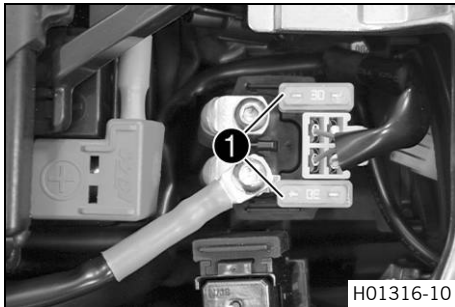



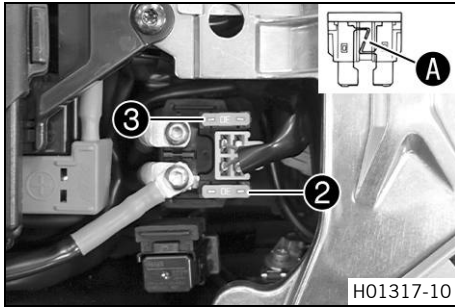

- Remove the faulty main fuse ②.



### Info

A defective fuse is indicated by a burned-out fuse wire A. A spare fuse ③ is located in the starter relay. The main fuse protects all power consumers of the vehicle.

- Install a new main fuse.

Fuse (58011109130) (📖 p. 205)

- Check that the electrical equipment is functioning properly.
- Mount the protection caps.



### Tip

Insert a new spare fuse into the starter relay to have it available when needed.

### Finishing work

- Mount the front rider's seat. (📖 p. 108)
- Mount the passenger seat. (📖 p. 106)
- Set the time and date.

## 16.7 Changing the fuses in the fuse box



### Warning

**Fire hazard** Incorrect fuses overload the electrical system.

- Only use fuses with the required ampere value.
- Do not bypass or repair fuses.



## Info

The fuse box containing the fuses of individual power consumers is located under the seat.

### Preparatory work

- Switch off the ignition by turning the black ignition key to the position **OFF** ☒.
- Remove the passenger seat. (📖 p. 106)
- Remove the front rider's seat. (📖 p. 107)

### Main work

- Open fuse box cover **1**.

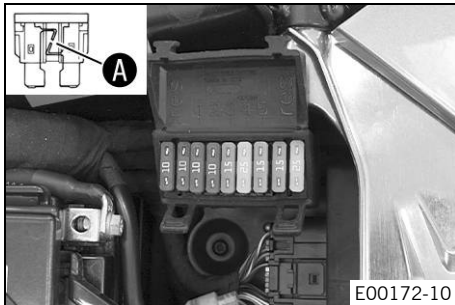
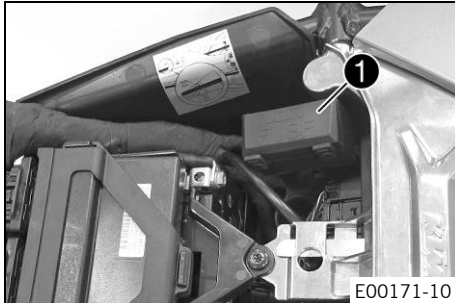

- Check the fuses.



## Info

A defective fuse is indicated by a burned-out fuse wire **A**.

- Remove the defective fuse.

## Guideline

Fuse <b>res</b> - 10 A - spare fuses
Fuse <b>res</b> - 10 A - spare fuses
Fuse <b>1</b> - 10 A - power supply, alarm system (optional), control units and components
Fuse <b>2</b> - 10 A - socket, license plate lamp, diagnostics connector, permanent positive for auxiliary equipment (ACC1+2)
Fuse <b>3</b> - 15 A - ABS hydraulic unit
Fuse <b>4</b> - 25 A - ABS return pump
Fuse <b>5</b> - 15 A - power supply, control unit, lighting system, and semi-active chassis
Fuse <b>res</b> - 15 A - spare fuse
Fuse <b>res</b> - 25 A - spare fuse

- Use spare fuses with the correct rating only.

Fuse (58011109110) (🔧 p. 204)
Fuse (58011109115) (🔧 p. 204)
Fuse (58011109125) (🔧 p. 205)



### Tip

Insert a spare fuse so that it is available if needed.

- Check that the power consumer is functioning properly.
- Close the fuse box cover.

### Finishing work

- Mount the front rider's seat. (🔧 p. 108)
- Mount the passenger seat. (🔧 p. 106)

## 16.8 Changing the headlight bulb

### Note

**Damage to reflector** Reduced brightness.

- Grease on the lamp will evaporate due to the heat and be deposited on the reflector. Clean the lamp and keep it free of grease before mounting.

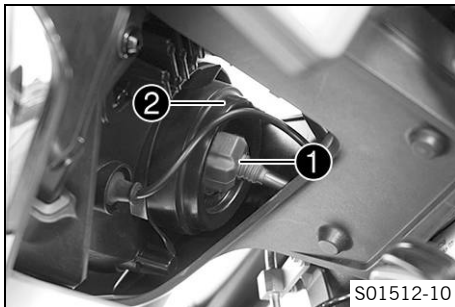

- Unplug connector ①.
- Take off rubber cap ②.

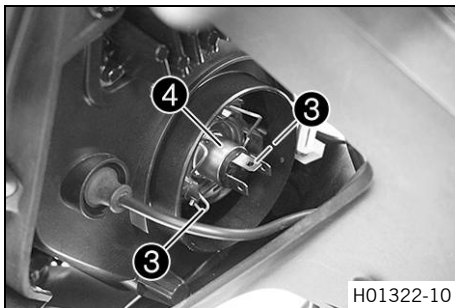

- Detach hangers ③.
- Remove bulb ④.
- Position the new bulb in the headlight housing.

Low beam/high beam (H4/socket P43t) (📖 p. 205)

- ✓ The projections in the headlight bulb engage in recesses.
- Attach hangers ③.

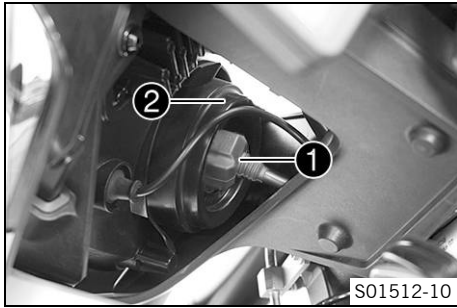

- Mount rubber cap ②.
- Plug in connector ①.

## 16.9 Checking the setting of the lighting system

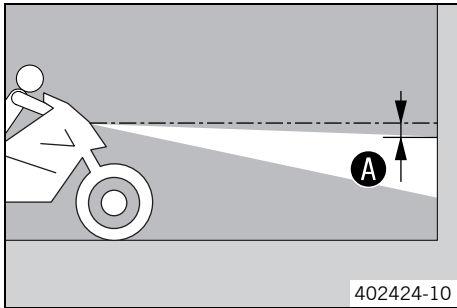

- Park the vehicle on a horizontal surface in front of a light-colored wall and make a mark at the height of the center of the low beam headlight.
- Make a second mark at a distance **A** under the first mark.

Guideline

Distance <b>A</b>	5 cm (2 in)
-------------------	-------------

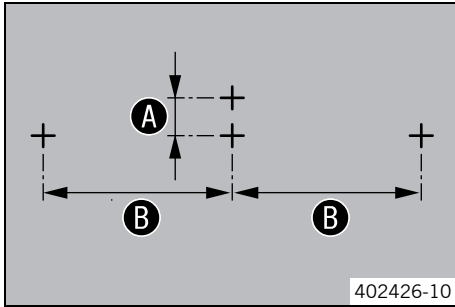

- Make two further marks spaced apart **B** to the left and the right of the second marking.

Guideline

Distance <b>B</b>	35.5 cm (13.98 in)
-------------------	--------------------

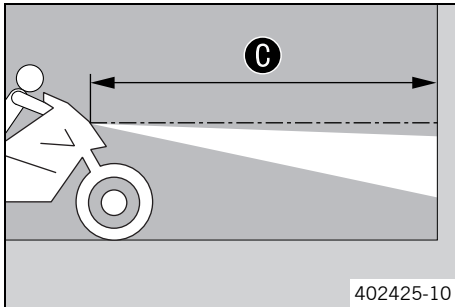

- Position the vehicle perpendicular to the wall at a distance **C** from the wall and switch on the low beam.

Guideline

Distance <b>C</b>	5 m (16 ft)
-------------------	-------------

- The rider, with luggage and passenger if applicable, now mounts the motorcycle.
- Check the headlight setting.

The light-dark boundary of the low beam must lie exactly on the lower mark when the motorcycle is ready to operate with the rider mounted along with any luggage and a passenger if applicable.

- » If the boundary between light and dark does not meet specifications:
  - Adjust the headlight range. (📖 p. 165)
- Press the **UP** or **DOWN** button until the "**Settings**" menu appears on the matrix display. Pressing the **SET** button opens the menu.
- Press the **UP** or **DOWN** button until "**cLightTest**" is highlighted in black on the matrix display. Pressing the **SET** button again starts the cornering light test.
- Wait for a few seconds until the upper segment of the left cornering light lights up continuously.

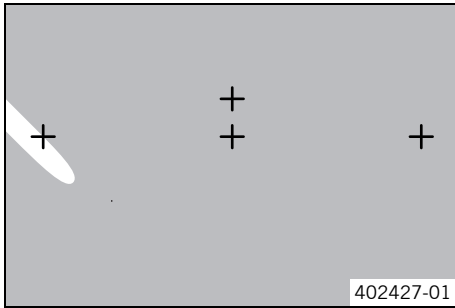

- Checking the left cornering light setting.

The light-dark boundary of the upper segment must run exactly through the left marking.

- » If the boundary between light and dark does not meet specifications:
  - Adjust the cornering light range. (📖 p. 166)
- Press the **SET** button.
  - ✓ The left cornering light is switched off.
  - ✓ The right cornering light test is started.
- Wait for a few seconds until the upper segment of the right cornering light lights up continuously.
- Checking the right cornering light setting.

The light-dark boundary of the upper segment must run exactly through the right marking.

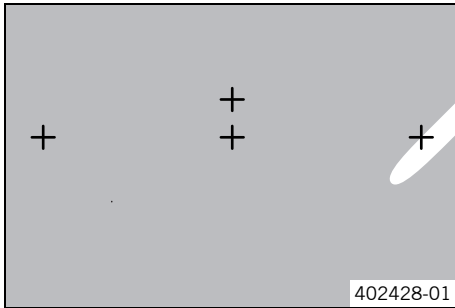

- » If the boundary between light and dark does not meet specifications:
  - Adjust the cornering light range. (📖 p. 166)
- Press the **SET** button.
  - ✓ The cornering light is switched off.

## 16.10 Adjusting the headlight range

### Preparatory work

- Check the setting of the lighting system. (📖 p. 163)

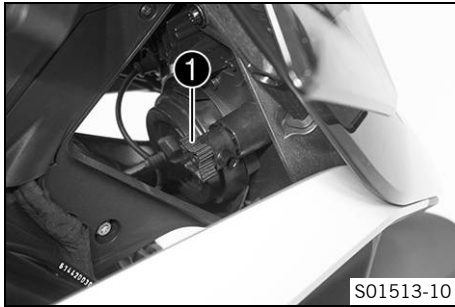

## Main work

- Turn adjusting screw **1** to adjust the headlight range.

## **i** Info

Turn clockwise to increase the headlight range; turn counterclockwise to reduce the headlight range.

If you have a payload, you may have to correct the headlight range.

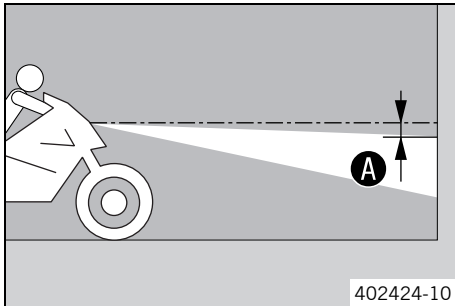

- Set the headlight to marking **A**.

## Guideline

The light-dark boundary must lie exactly on lower mark **A** when the motorcycle is ready to operate with the rider mounted along with any luggage and a passenger if applicable.

## 16.11 Adjusting the cornering light range

### Preparatory work

- Check the setting of the lighting system. (📖 p. 163)

### Main work

- Press the **UP** or **DOWN** button until the "**Settings**" menu appears on the matrix display. Pressing the **SET** button opens the menu.
- Press the **UP** or **DOWN** button until "**cLightTest**" is highlighted in black on the matrix display. Pressing the **SET** button again starts the cornering light test.



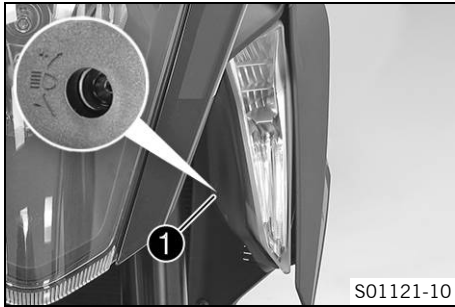

- Wait for a few seconds until the upper segment of the left cornering light lights up continuously.
- Turn adjusting screw **1** to adjust the left cornering light range.

Guideline

Carefully turn the adjusting screw; do not use force to avoid damaging the adjuster mechanism.	
Adjusting screw torque	≤ 0.25 Nm (≤ 0.184 lbf ft)

**i** Info

Turn clockwise to increase the headlight range; turn counterclockwise to reduce the headlight range.  
If you have a payload, you may have to correct the headlight range.

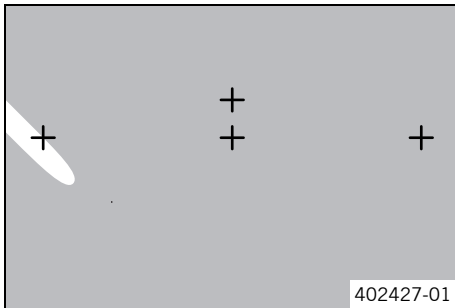

- Set the upper segment on the left marking.

Guideline

The light-dark boundary of the upper segment must run exactly through the left marking.
---

- Press the **SET** button.
  - ✓ The left cornering light is switched off.
  - ✓ The right cornering light test is started.
- Wait for a few seconds until the upper segment of the right cornering light lights up continuously.

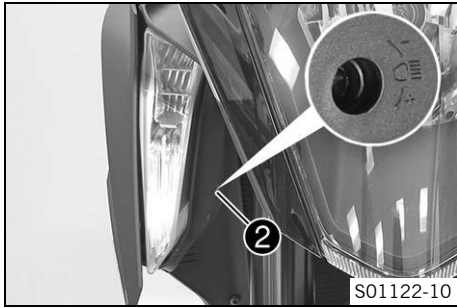

- Turn adjusting screw ② to adjust the right cornering light range.

Guideline

Carefully turn the adjusting screw; do not use force to avoid damaging the adjuster mechanism.

Adjusting screw torque	$\leq 0.25 \text{ Nm}$ ( $\leq 0.184 \text{ lbf ft}$ )
------------------------	--

**i** Info

Turn clockwise to increase the headlight range; turn counterclockwise to reduce the headlight range.

If you have a payload, you may have to correct the headlight range.

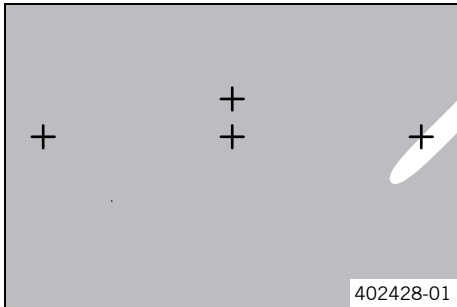

- Set the upper segment on the left marking.

Guideline

The light-dark boundary of the upper segment must run exactly through the right marking.

- Press the **SET** button.
  - ✓ The cornering light is switched off.

## 16.12 Activating/deactivating the ignition key

### **i** Info

The orange programming key must only be used for activating and deactivating!

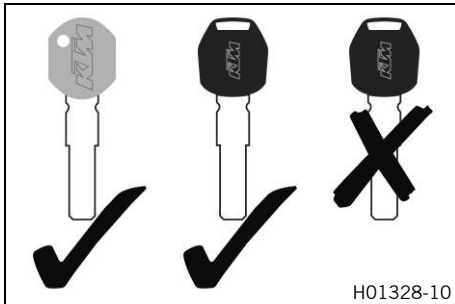

If a black ignition key is lost or needs to be replaced, the individual black ignition keys need to be enabled or disabled using the orange programming key. This prevents the vehicle from being operated with the lost black ignition key.

You can activate or deactivate up to four black ignition keys. Only the black ignition keys programmed during an activation procedure are valid. All black ignition keys not programmed during the activation procedure are invalid, but can be reprogrammed in a further activation procedure.



### **Loss of a black ignition key (additional black ignition keys are available):**

The following procedure deactivates all activated black ignition keys that are not included in the procedure.

- Press the emergency OFF switch to the position **ON** ○.
- Insert the orange programming key in the ignition lock.
- Switch on the ignition by turning the orange programming key to the position **ON** ○.
  - ✓ Immobilizer indicator lamp  lights up.
- Switch off the ignition by turning the orange programming key to the position **OFF** ⊗.
- Pull out the orange programming key.
- Insert the black ignition key in the ignition lock.
- Switch on the ignition by turning the black ignition key to the position **ON** ○.
  - ✓ Immobilizer indicator lamp  lights up.

- Switch off the ignition by turning the black ignition key to the position **OFF** ☒.
- Remove the black ignition key.
- Insert the orange programming key in the ignition lock.
- Switch on the ignition by turning the orange programming key to the position **ON** ○.
- ✓ The immobilizer indicator lamp ■ flashes according to the number of functional black ignition keys including the orange programming key. In this case, it flashes twice.
- Switch off the ignition by turning the orange programming key to the position **OFF** ☒.
- Pull out the orange programming key.
- ✓ The lost black ignition key is deactivated.
- ✓ The existing black ignition key is reactivated.

**Loss of all black ignition keys (no black ignition keys are available):**

This procedure is important to prevent misuse of the lost black ignition key.

- Press the emergency OFF switch to the position **ON** ○.

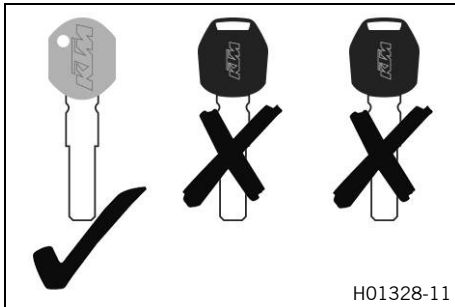



- Insert the orange programming key in the ignition lock.
- Switch on the ignition by turning the orange programming key to the position **ON** ○.
- ✓ Immobilizer indicator lamp ■ lights up.
- Switch off the ignition by turning the orange programming key to the position **OFF** ⊗.
- Switch on the ignition by turning the orange programming key to the position **ON** ○.
- ✓ The immobilizer indicator lamp ■ flashes according to the number of functional black ignition keys including the orange programming key. In this case, it flashes once since all black ignition keys are deactivated.
- Switch off the ignition by turning the orange programming key to the position **OFF** ⊗.
- Pull out the orange programming key.
- ✓ All black ignition keys are deactivated.
- Order a new black ignition key according to the key number on the **KEYCODECARD** and activate it.

### To activate up to three black ignition keys:

- Press the emergency OFF switch to the position **ON** ○.
- Insert the orange programming key in the ignition lock.
- Switch on the ignition by turning the orange programming key to the position **ON** ○.
- ✓ Immobilizer indicator lamp ■ lights up.
- Switch off the ignition by turning the orange programming key to the position **OFF** ⊗.
- Pull out the orange programming key.
- Insert the black ignition key in the ignition lock.
- Switch on the ignition by turning the black ignition key to the position **ON** ○.
- ✓ Immobilizer indicator lamp ■ lights up.
- Switch off the ignition by turning the black ignition key to the position **OFF** ⊗.
- Remove the black ignition key.
- If two other black ignition keys are to be activated, repeat the last steps with the respective ignition key.

- If the last black ignition key was activated, insert the orange programming key into the ignition lock.
- Switch on the ignition by turning the orange programming key to the position **ON** ○.
- ✓ The immobilizer indicator lamp ■ flashes according to the number of functional black ignition keys including the orange programming key.
- Switch off the ignition by turning the orange programming key to the position **OFF** ⊗.
- Pull out the orange programming key.



### Info

Activation of the ignition key is finished.

---

#### To activate four black ignition keys:

- Press the emergency OFF switch to the position **ON** ○.
- Insert the orange programming key in the ignition lock.
- Switch on the ignition by turning the orange programming key to the position **ON** ○.
- ✓ Immobilizer indicator lamp ■ lights up.
- Switch off the ignition by turning the orange programming key to the position **OFF** ⊗.
- Pull out the orange programming key.
- Insert the black ignition key in the ignition lock.
- Switch on the ignition by turning the black ignition key to the position **ON** ○.
- ✓ Immobilizer indicator lamp ■ lights up.
- Switch off the ignition by turning the black ignition key to the position **OFF** ⊗.
- Remove the black ignition key.
- If three other black ignition keys are to be activated, repeat the last steps with the respective ignition key.

**Info**

After the fourth black ignition key has been activated, programming is finished.

## 16.13 Diagnostics connector

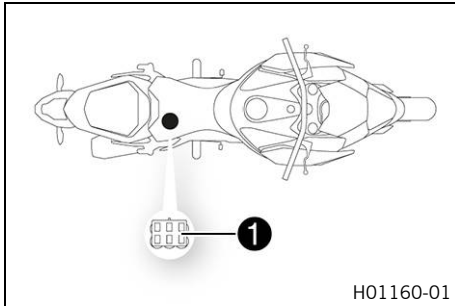

Diagnostics connector **1** is located under the front rider's seat.

## 16.14 ACC1 and ACC2 front

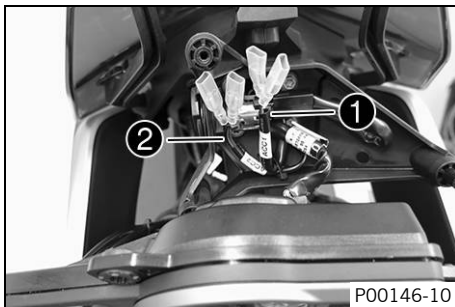

The front power supplies ACC1 **1** and ACC2 **2** are located at the front behind the combination instrument.

## 16.15 ACC1 and ACC2 rear

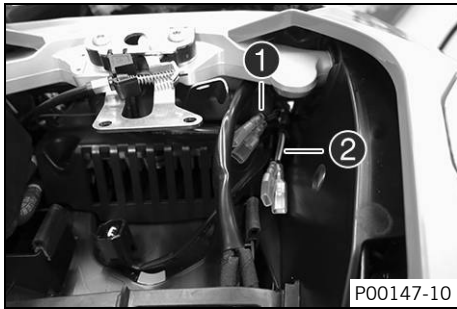

The rear power supplies ACC1 ① and ACC2 ② are located on the right next to the passenger seat lock.



## 17.1 Checking the coolant level in the compensating tank



### Warning

**Danger of scalding** During motorcycle operation, the coolant gets very hot and is under pressure.

- Do not open the radiator, the radiator hoses or other cooling system components if the engine or the cooling system are at operating temperature.
- Allow the cooling system and the engine to cool down before you open the radiator, the radiator hoses or other components of the cooling system.
- In the event of scalding, rinse the area affected immediately with lukewarm water.



### Warning

**Danger of poisoning** Coolant is toxic and a health hazard.

- Keep coolant out of the reach of children.
- Do not allow coolant to come into contact with the skin, the eyes and clothing.
- Consult a doctor immediately if coolant is swallowed.
- Rinse the affected area immediately with plenty of water in the event of contact with the skin.
- Rinse eyes thoroughly with water and consult a doctor immediately if coolant gets into the eyes.
- Change clothing if coolant spills onto your clothing.

---

### Condition

The engine is cold.

The radiator is completely full.

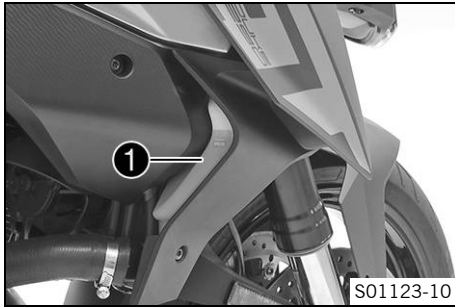

- Park the motorcycle on a horizontal surface.
- Check the coolant level in compensating tank ①.

The coolant level must be between **MIN** and **MAX**.

- » If there is no coolant in the compensating tank:
  - Check the cooling system for leaks. 🛠️



### Info

Do not start up the motorcycle!

- Add coolant/bleed the cooling system. 🛠️
- » If the coolant in the compensating tank is not at the required level, but the tank is not empty:
  - Correct the coolant level in the compensating tank. (📖 p. 176)

## 17.2 Correcting the coolant level in the compensating tank



### Warning

**Danger of scalding** During motorcycle operation, the coolant gets very hot and is under pressure.

- Do not open the radiator, the radiator hoses or other cooling system components if the engine or the cooling system are at operating temperature.
- Allow the cooling system and the engine to cool down before you open the radiator, the radiator hoses or other components of the cooling system.
- In the event of scalding, rinse the area affected immediately with lukewarm water.



## Warning

**Danger of poisoning** Coolant is toxic and a health hazard.

- Keep coolant out of the reach of children.
  - Do not allow coolant to come into contact with the skin, the eyes and clothing.
  - Consult a doctor immediately if coolant is swallowed.
  - Rinse the affected area immediately with plenty of water in the event of contact with the skin.
  - Rinse eyes thoroughly with water and consult a doctor immediately if coolant gets into the eyes.
  - Change clothing if coolant spills onto your clothing.
- 

## Condition

The engine is cold.

The radiator is completely full.

## Preparatory work

- Check the coolant level in the compensating tank. (📖 p. 175)

## Main work

- Remove the tank spoiler. (📖 p. 122)
- 



## Info

Only disassemble the right-hand side.

---

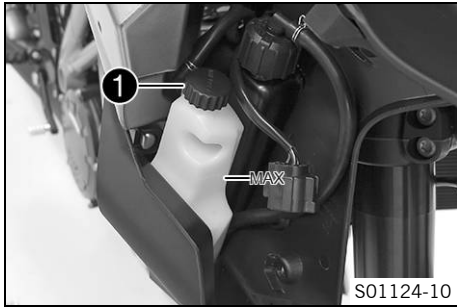

- Remove cover ❶ of the compensating tank.
- Add coolant to the **MAX** marking.

Coolant (📖 p. 212)

- Mount cover ❶ on the compensating tank.

### Finishing work

- Install the tank spoiler. (📖 p. 123)

## 18.1 "Drive Mod"

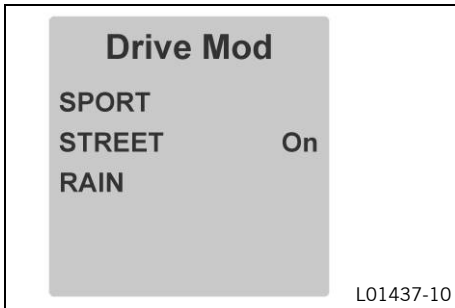

### Possible states

- SPORT – Homologated performance with very direct response; the traction control allows greater slip on the rear wheel
- STREET – Homologated performance with balanced response; the traction control allows normal slip on the rear wheel
- RAIN – Reduced homologated performance for better rideability; the traction control allows normal slip on the rear wheel

Various vehicle tunings can be selected in the **"Drive Mod"** menu. You can choose from **"SPORT"**, **"STREET"**, and **"RAIN"**.

The drive mode selected last is displayed on the right in the segment display.



### Info

The drive mode selection has no influence on the ABS.

## 18.2 Motorcycle traction control (MTC)

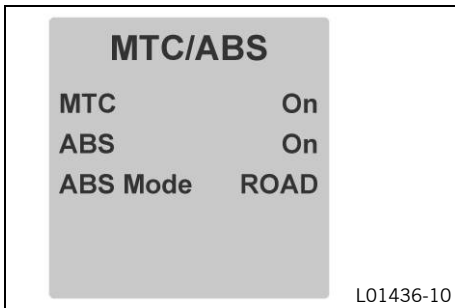

The motorcycle traction control (MTC) reduces the engine torque in case of loss of traction on the rear wheel.



### Info

When motorcycle traction control is switched off, the rear wheel may spin during high acceleration and on surfaces with low grip.  
After the ignition is switched back on, the motorcycle traction control is reactivated.

The motorcycle traction control is operated through the **"Drive Mode"** (🗨 p. 179) menu on the combination instrument. The motorcycle traction control can be switched off in the **"MTC/ABS"** menu.



## Info

When motorcycle traction control is active, the TC lamp  flashes.

When motorcycle traction control is switched off, the TC lamp  lights up.

---

## 19.1 Checking the engine oil level



### Info

Oil consumption depends on the riding style and the operating conditions.

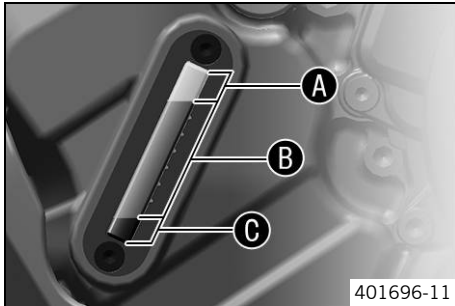

### Condition

The engine is at operating temperature.

### Preparatory work

- Stand the motorcycle upright on a horizontal surface.

### Main work

- Check the engine oil level in the engine oil level viewer.



### Info

After switching off the engine, wait one minute before checking the level.

The engine oil level should be in the upper area **B** of the engine oil level viewer.

- » When the engine oil level is in area **A** of the engine oil level viewer:
  - Do not add engine oil.
- » When the engine oil level is in area **B** of the engine oil level viewer:
  - Engine oil can be added.
- » When the engine oil level is in area **C** of the engine oil level viewer:
  - Add engine oil. (📖 p. 187)

## 19.2 Changing the engine oil and oil filter, cleaning the oil screens ↩



### Warning

**Danger of scalding** Engine and gear oil get very hot when the motorcycle is ridden.

- Wear suitable protective clothing and safety gloves.
- In the event of scalding, rinse the area affected immediately with lukewarm water.



### Warning

**Environmental hazard** Hazardous substances cause environmental damage.

- Dispose of oils, grease, filters, fuel, cleaning agents, brake fluid, etc., correctly and in compliance with the applicable regulations.

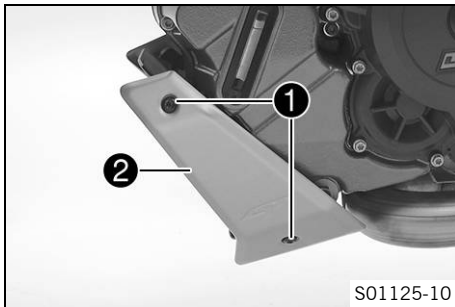

### Main work

- Stand the motorcycle on its side stand on a horizontal surface.
- Remove screws ①.
- Take off plate ②.



# 19 SERVICE WORK ON THE ENGINE

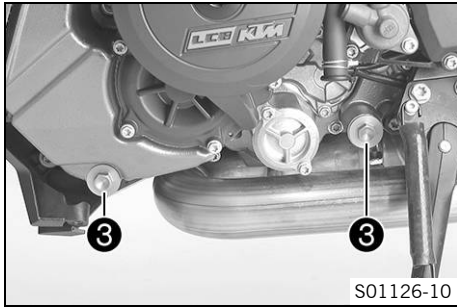

- Place a suitable container under the engine.
- Remove oil drain plugs **3** with the magnets, O-rings, and oil screens.

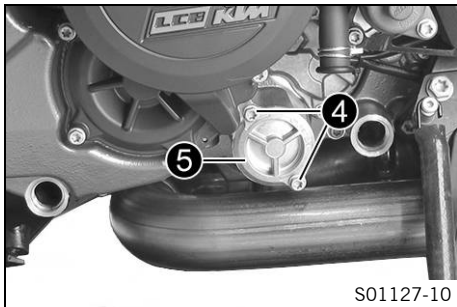

- Remove screws **4**. Remove oil filter cover **5** with the O-ring.

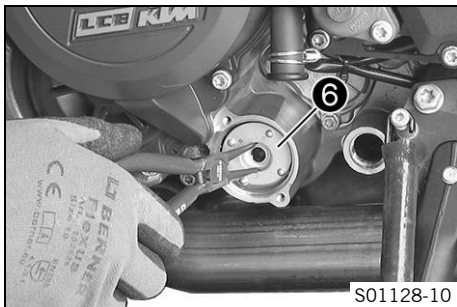

- Pull oil filter **6** out of the oil filter housing.

Circlip pliers reverse (51012011000)

- Completely drain the engine oil.
- Thoroughly clean the parts and sealing surfaces.

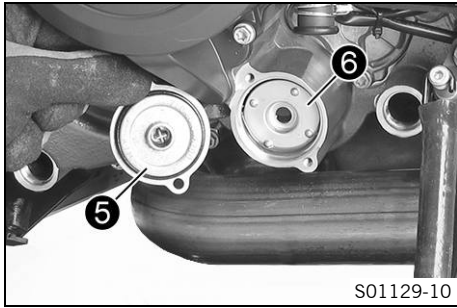

S01129-10

- Insert new oil filter **6**.



**Info**

Only insert the oil filter by hand.

- Lubricate the O-ring of the oil filter cover. Mount oil filter cover **5**.

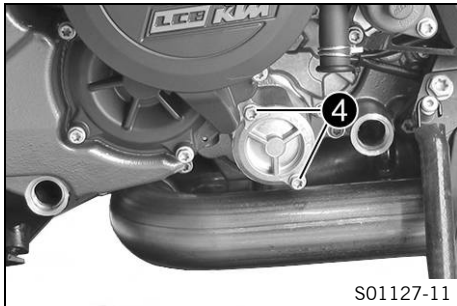

S01127-11

- Mount and tighten screws **4**.

Guideline

Remaining engine screws	M5	6 Nm (4.4 lbf ft)
-------------------------	----	-------------------

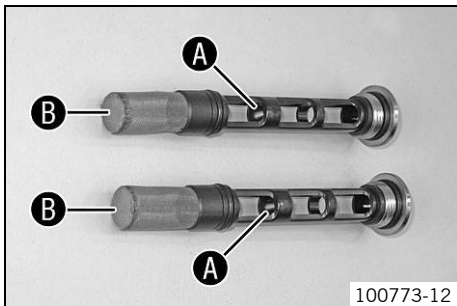

100773-12

- Thoroughly clean magnets **A** and oil screens **B** of the oil drain plugs.

# 19 SERVICE WORK ON THE ENGINE

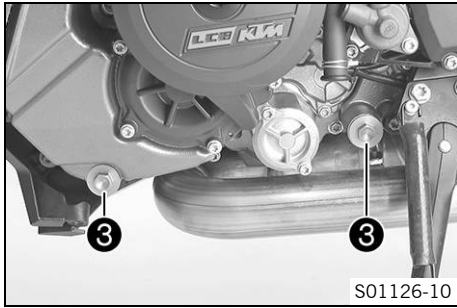

- Mount and tighten oil drain plugs **3** with the magnets, O-rings, and oil screens.

Guideline

Oil drain plug	M20x1.5	20 Nm (14.8 lbf ft)
----------------	---------	------------------------

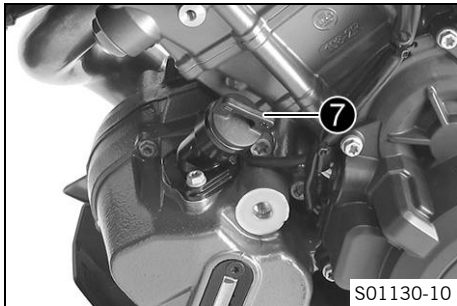

- Add the oil quantity in two separate operations.

Engine oil	3.50 l (3.7 qt.)	Outside temperature: ≥ 0 °C (≥ 32 °F)	Engine oil (SAE 10W/50) (📖 p. 213)
		Outside temperature: < 0 °C (< 32 °F)	Engine oil (SAE 5W/40) (📖 p. 213)

- Remove screw plug **7** and fill in engine oil.

Engine oil (1st quantity), approx.	3.0 l (3.2 qt.)	Outside temperature: ≥ 0 °C (≥ 32 °F)	Engine oil (SAE 10W/50) (📖 p. 213)
		Outside temperature: < 0 °C (< 32 °F)	Engine oil (SAE 5W/40) (📖 p. 213)

- Mount screw plug **7**.

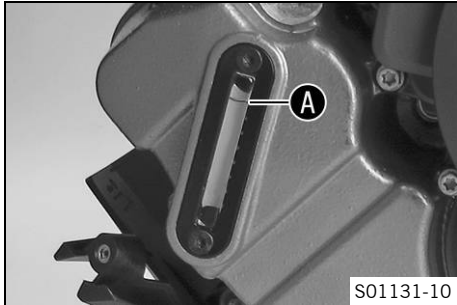

**Danger**

**Danger of poisoning** Exhaust gases are toxic and inhaling them may result in unconsciousness and death.

- Always make sure there is sufficient ventilation when running the engine.
- Use an effective exhaust extraction system when starting or running the engine in an enclosed space.

- 
- Start the engine and check that it is oil-tight.
  - Remove the screw plug and add the remaining engine oil to upper marking **A** on the engine oil level viewer.
  - Mount the screw plug.



**Danger**

**Danger of poisoning** Exhaust gases are toxic and inhaling them may result in unconsciousness and death.

- Always make sure there is sufficient ventilation when running the engine.
- Use an effective exhaust extraction system when starting or running the engine in an enclosed space.

- 
- Start the engine and check that it is oil-tight.

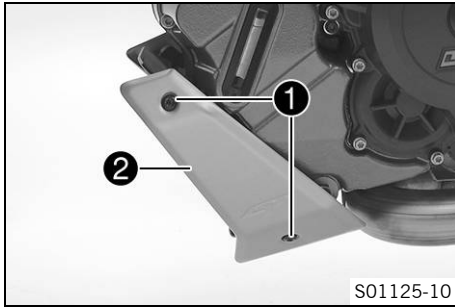

- Position plate ②.
- Mount and tighten screws ①.

Guideline

Remaining screws, chassis	M5	5 Nm (3.7 lbf ft)
---------------------------	----	-------------------

### Finishing work

- Check the engine oil level. (📖 p. 181)

## 19.3 Adding engine oil



### Info

Too little engine oil or poor-quality engine oil results in premature wear to the engine. The engine may be damaged if the engine oil level is too high.

### Condition

The engine is at operating temperature.

### Preparatory work

- Stand the motorcycle upright on a horizontal surface.
- Check the engine oil level. (📖 p. 181)

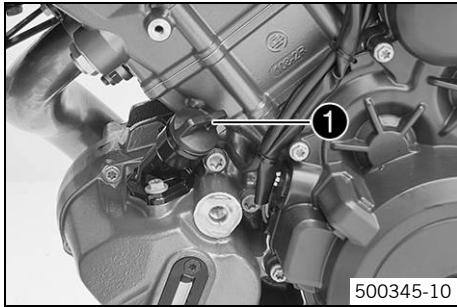

## Main work

- Remove screw plug 1.

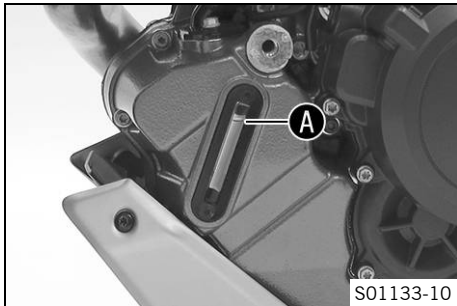

- Add engine oil to upper marking A on the engine oil level viewer.

## Condition

Outside temperature:  $\geq 0\text{ }^{\circ}\text{C}$  ( $\geq 32\text{ }^{\circ}\text{F}$ )

Engine oil (SAE 10W/50) (📖 p. 213)

## Condition

Outside temperature:  $< 0\text{ }^{\circ}\text{C}$  ( $< 32\text{ }^{\circ}\text{F}$ )

Engine oil (SAE 5W/40) (📖 p. 213)



## Info

In order to achieve optimal engine performance, it is not advisable to mix different engine oils.

KTM recommends changing the engine oil.

- Mount the screw plug.



## **Danger**

**Danger of poisoning** Exhaust gases are toxic and inhaling them may result in unconsciousness and death.

- Always make sure there is sufficient ventilation when running the engine.
- Use an effective exhaust extraction system when starting or running the engine in an enclosed space.

- 
- Start the engine and check that it is oil-tight.

## **Finishing work**

- Check the engine oil level. (📖 p. 181)

## 20.1 Cleaning motorcycle

---

### Note

**Material damage** Components become damaged or destroyed if a pressure cleaner is used incorrectly.

The high pressure forces water into the electrical components, connectors, throttle cables, and bearings, etc. Pressure which is too high causes malfunctions and destroys components.

- Do not direct the water jet directly on to electrical components, connectors, throttle cables or bearings.
- Maintain a minimum distance between the nozzle of the pressure cleaner and the component.

Minimum clearance 60 cm (23.6 in)



### Warning

**Environmental hazard** Hazardous substances cause environmental damage.

- Dispose of oils, grease, filters, fuel, cleaning agents, brake fluid, etc., correctly and in compliance with the applicable regulations.
- 



### Info

If you clean the motorcycle regularly, its value and appearance will be maintained over a long period. Avoid direct sunshine on the motorcycle during cleaning.

---



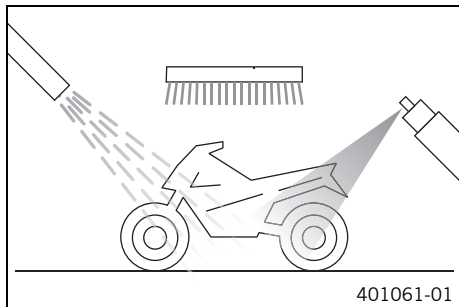

- Close off the exhaust system to keep water from entering.
- First remove coarse dirt particles with a gentle spray of water.
- Spray very dirty areas with a normal motorcycle cleaner and then clean with a brush.

Motorcycle cleaner (📖 p. 215)

### **i** Info

Use warm water containing normal motorcycle cleaner and a soft sponge. Never apply motorcycle cleaner to a dry vehicle; always rinse the vehicle with water first. If the vehicle was operated in road salt, clean it with cold water. Warm water would enhance the corrosive effects of salt.

- After rinsing the motorcycle with a gentle spray of water, allow it to dry thoroughly.
- Remove the closure of the exhaust system.



### **Warning**

**Danger of accidents** Moisture and dirt impair the brake system.

- Brake carefully several times to dry out and remove dirt from the brake linings and the brake discs.
- After cleaning, ride the vehicle a short distance until the engine warms up.

### **i** Info

The heat produced causes water at inaccessible locations in the engine and on the brake system to evaporate.

- Push back the protection caps of the handlebar controls to allow any water that has penetrated to evaporate.
- After the motorcycle has cooled off, lubricate all moving parts and bearings.
- Clean the chain. (📖 p. 112)

- Treat bare metal parts (except for brake discs and exhaust system) with corrosion inhibitor.

Preserving materials for paints, metal and rubber (📖 p. 216)

- Treat the painted parts with a mild paint polish.

Perfect Finish and high gloss polish for paints (📖 p. 216)



### Info

Do not polish plastic parts that are matte when the vehicle is delivered as this would seriously impair the material quality.

- Treat the plastic parts and powder-coated parts with a mild cleaning and care product.

Special cleaner for glossy and matte paint finishes, metal and plastic surfaces (📖 p. 216)

- Oil the ignition/steering lock, tank lock, and seat lock.

Universal oil spray (📖 p. 216)

## 20.2 Checks and maintenance steps for winter operation



### Info

If you use the motorcycle in winter, you must expect salt on the roads. You should therefore take precautions against aggressive road salt.

If the vehicle was operated in road salt, clean it with cold water after riding. Warm water would enhance the corrosive effects of salt.

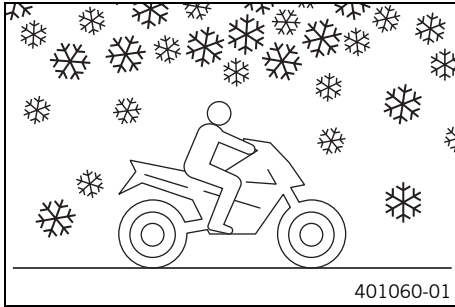

- Clean the motorcycle. (📖 p. 190)
  - Clean the brakes.
- 



### Info

After **EVERY** trip on salted roads, thoroughly wash the brake calipers and brake linings with cold water and dry carefully. This should be done after the parts are cooled down and while they are installed.

After riding on salted roads, thoroughly wash the motorcycle with cold water and dry it well.

---

- Treat the engine, the swingarm, and all other bare or galvanized parts (except brake discs) with a wax-based corrosion inhibitor.
- 



### Info

Corrosion inhibitor must not come into contact with the brake discs. This would severely lower the braking effect.

---

- Clean the chain. (📖 p. 112)

## 21.1 Storage

### **i** Info

If you plan to garage the motorcycle for a longer period, perform the following steps or have them performed. Before storing the motorcycle, check all parts for function and wear. If service, repairs or replacements are necessary, you should do this during the storage period (less workshop overload). In this way, you can avoid long workshop waiting times at the start of the new season.

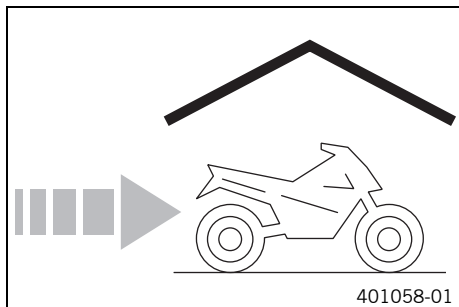

- When refueling for the last time before taking the motorcycle out of service, add fuel additive.

Fuel additive (📖 p. 215)
--------------------------

- Refuel. (📖 p. 95)
- Clean the motorcycle. (📖 p. 190)
- Change the engine oil and oil filter and clean the oil screens. 🛠️ (📖 p. 182)
- Check the coolant fill level and antifreeze. 🛠️
- Check the tire air pressure. (📖 p. 147)
- Remove the battery. 🛠️ (📖 p. 150)

#### Guideline

Storage temperature of battery without direct sunshine	0... 35 °C (32... 95 °F)
--	--------------------------

- Recharge the battery. 🛠️ (📖 p. 154)
- Store the vehicle in a dry location that is not subject to large fluctuations in temperature.

### **i** Info

KTM recommends jacking up the motorcycle.

- Lift the motorcycle with the rear lifting gear. (📖 p. 103)

- Lift the motorcycle with the front lifting gear. (📖 p. 104)
- Cover the vehicle with a tarp or similar cover that is permeable to air.

## **i** Info

Do not use non-porous materials since they prevent humidity from escaping, thus causing corrosion.

Avoid running the engine for a short time only. Since the engine cannot warm up properly, the water vapor produced during combustion condenses and causes valves and the exhaust system to rust.

## 21.2 Preparing for use after storage

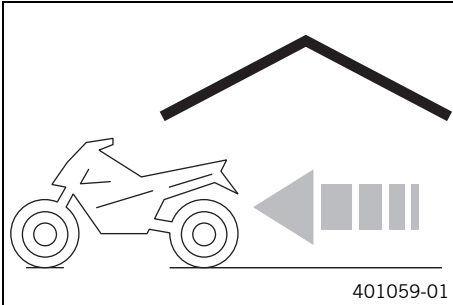

- Take the motorcycle from the front lifting gear. (📖 p. 105)
- Remove the rear of the motorcycle from the lifting gear. (📖 p. 103)
- Install the battery. 🛠️ (📖 p. 152)

## **i** Info

If the battery has been removed, the time and date must be set.

- Perform checks and maintenance measures when preparing for use. (📖 p. 81)
- Take a test ride.

Faults	Possible cause	Action
The combination instrument shows nothing on the display	Fuse 1 is blown	– Change the fuses in the fuse box. (📖 p. 159)
	The main fuse is blown	– Change the main fuse. (📖 p. 158)
	The battery is discharged	– Recharge the battery. 🛡️ (📖 p. 154)
		– Check the open-circuit current. 🛡️
The ignition/steering lock is faulty	– Check the ignition/steering lock. 🛡️	
The engine does not crank when the electric starter button is pressed	The emergency OFF switch is off	– Press the emergency OFF switch to the position <b>ON</b> ○.
	Operating error	– Carry out the start procedure. (📖 p. 82)
	The battery is discharged	– Recharge the battery. 🛡️ (📖 p. 154)
		– Check the open-circuit current. 🛡️
	The safety start system is faulty	– Read out the fault memory using the KTM diagnostics tool. 🛡️
	CAN bus communication error	– Read out the fault memory using the KTM diagnostics tool. 🛡️
	Fault in EFI control unit.	– Read out the fault memory using the KTM diagnostics tool. 🛡️
Fault in the MCU control unit.	– Read out the fault memory using the KTM diagnostics tool. 🛡️	
The engine only turns if the clutch lever is drawn	The vehicle is in gear	– Shift the transmission to idle <b>N</b> .
	The safety start system is faulty	– Read out the fault memory using the KTM diagnostics tool. 🛡️
The engine turns although a gear is engaged	The safety start system is faulty	– Read out the fault memory using the KTM diagnostics tool. 🛡️
The engine turns but does not start	The coupling of the fuel hose connection is not connected	– Reconnect the coupling of the fuel hose connection.

Faults	Possible cause	Action
The engine turns but does not start	Defect in the fuel injection system	– Read out the fault memory using the KTM diagnostics tool. 🛠️
	The fuel quality is insufficient	– Add suitable fuel.
The engine dies during the trip	Lack of fuel	– Refuel. (📖 p. 95)
	Defect in the fuel injection system	– Read out the fault memory using the KTM diagnostics tool. 🛠️
The engine warning lamp lights up/flashes	Defect in the fuel injection system	– Read out the fault memory using the KTM diagnostics tool. 🛠️
The ABS warning lamp lights up	The ABS fuse is blown	– Change the fuses in the fuse box. (📖 p. 159)
	Large difference in wheel speeds of the front and rear wheels	– Stop the vehicle, switch off the ignition, and start it again.
	Malfunction in ABS	– Read out the fault memory using the KTM diagnostics tool. 🛠️
High oil consumption	The engine oil level is too high	– Check the engine oil level. (📖 p. 181)
	The engine oil is too thin (low viscosity)	– Change the engine oil and oil filter and clean the oil screens. 🛠️ (📖 p. 182)
The battery is discharged	The hazard warning flasher is switched on	– Switch off the hazard warning flasher. – Recharge the battery. 🛠️ (📖 p. 154)
	The battery is not being charged by the alternator	– Check the charging voltage. 🛠️
	The ignition was not switched off while the vehicle was parked	– Recharge the battery. 🛠️ (📖 p. 154)

## 23.1 Engine

Design	2-cylinder 4-stroke Otto engine, 75° V arrangement, water-cooled
Displacement	1,301 cm <sup>3</sup> (79.39 cu in)
Stroke	71 mm (2.8 in)
Bore	108 mm (4.25 in)
Compression ratio	13.1:1
Idle speed	1,250... 1,450 rpm
Control	DOHC, 4 valves per cylinder, chain-driven
Valve - valve plate diameter	
Intake	42 mm (1.65 in)
Exhaust	34 mm (1.34 in)
Valve clearance	
Exhaust at: 20 °C (68 °F)	0.25... 0.30 mm (0.0098... 0.0118 in)
Intake at: 20 °C (68 °F)	0.10... 0.15 mm (0.0039... 0.0059 in)
Crankshaft bearing	Sleeve bearing
Conrod bearing	Sleeve bearing
Piston	Forged light alloy
Piston ring	1 upper compression (rectangular) ring, 1 lower compression ring, 1 oil scraper ring
Engine lubrication	Dry sump lubrication system with three rotor pumps
Primary transmission	40:76
Clutch	Antihopping clutch in oil bath/hydraulically operated
Transmission	6-speed claw gears
Transmission ratio	



1st gear	12:35
2nd gear	15:32
3rd gear	18:30
4th gear	20:27
5th gear	24:27
6th gear	27:26
Mixture preparation	Electronically controlled fuel injection
Ignition system	Contactless controlled fully electronic ignition with digital ignition adjustment
Alternator	14 V, 448 W
Spark plug	
Inside spark plug	NGK LKAR9BI-10
Outside spark plug	NGK LMAR7DI-10
Electrode gap, spark plug	1 mm (0.04 in)
Cooling	Water cooling, permanent circulation of coolant by water pump
Cold start device	Electric starter

## 23.2 Engine tightening torques

Screw, damping plate	<b>EJOT Altracs®</b> M6x14	10 Nm (7.4 lbf ft)	<b>Loctite® 243™</b>
Screw, retaining bracket, valve cover, rear	<b>EJOT Altracs®</b> M6x10	10 Nm (7.4 lbf ft)	–
Hose clip, intake flange	M4	1.5 Nm (1.11 lbf ft)	–
Oil nozzle	M5	2 Nm (1.5 lbf ft)	<b>Loctite® 243™</b>
Remaining engine screws	M5	6 Nm (4.4 lbf ft)	–
Screw swing arm sensor	M5	5 Nm (3.7 lbf ft)	<b>Loctite® 243™</b>

Screw, bearing retainer	M5	6 Nm (4.4 lbf ft)	Loctite® 243™
Screw, bearing shells retaining bracket	M5	6 Nm (4.4 lbf ft)	Loctite® 243™
Screw, engine oil level viewer	M5	4 Nm (3 lbf ft)	–
Screw, gear sensor	M5	6 Nm (4.4 lbf ft)	Loctite® 243™
Screw, pulse generator	M5	6 Nm (4.4 lbf ft)	Loctite® 243™
Bleeder screw, water pump cover	M6	10 Nm (7.4 lbf ft)	–
Coolant connection screw on the cylinder head	M6	8 Nm (5.9 lbf ft)	Loctite® 243™
Freewheel ring bolt	M6 – 10.9	15 Nm (11.1 lbf ft)	Loctite® 648™
Nut, cylinder head	M6	9 Nm (6.6 lbf ft)	–
Remaining engine screws	M6	10 Nm (7.4 lbf ft)	–
Screw, camshaft bearing support	M6 – 10.9	10 Nm (7.4 lbf ft)	–
Screw, clutch cover	M6	10 Nm (7.4 lbf ft)	–
Screw, clutch spring	M6	12 Nm (8.9 lbf ft)	–
Screw, engine case	M6	10 Nm (7.4 lbf ft)	–
Screw, freewheel holder	M6	10 Nm (7.4 lbf ft)	Loctite® 243™
Screw, locking lever	M6	10 Nm (7.4 lbf ft)	Loctite® 243™
Screw, oil pump cover	M6	10 Nm (7.4 lbf ft)	Loctite® 243™
Screw, shift drum locating	M6	18 Nm (13.3 lbf ft)	Loctite® 243™
Screw, shift lever	M6	15 Nm (11.1 lbf ft)	Loctite® 243™
Screw, starter motor	M6	10 Nm (7.4 lbf ft)	–
Screw, stator	M6	10 Nm (7.4 lbf ft)	Loctite® 243™
Screw, valve cover	M6	10 Nm (7.4 lbf ft)	–
Screw, water pump cover	M6	10 Nm (7.4 lbf ft)	–
Screw, water pump wheel	M6	10 Nm (7.4 lbf ft)	Loctite® 243™

Stud, chain shaft	M6	8 Nm (5.9 lbf ft)	–
Vacuum connection	M6	5 Nm (3.7 lbf ft)	<b>Loctite® 243™</b>
Nozzle 100	M6x0.75	4 Nm (3 lbf ft)	<b>Loctite® 243™</b>
Plug, crankshaft retainer	M8	15 Nm (11.1 lbf ft)	–
Screw, camshaft bearing support	M8 – 10.9	Step 1 10 Nm (7.4 lbf ft) Step 2 18 Nm (13.3 lbf ft)	–
Screw, camshaft bearing support	M8 – 10.9	Step 1 8.5 Nm (6.27 lbf ft) Step 2 14.5 Nm (10.7 lbf ft)	Only applies when using: Hex key bit (61229025000)
Screw, engine case	M8	18 Nm (13.3 lbf ft)	–
Screw, timing chain guide rail	M8	15 Nm (11.1 lbf ft)	<b>Loctite® 243™</b>
Stud, exhaust flange	M8	10 Nm (7.4 lbf ft)	–
Timing chain tensioning rail screw	M8	15 Nm (11.1 lbf ft)	<b>Loctite® 243™</b>
Screw, engine bearer	M10	45 Nm (33.2 lbf ft)	–
Oil pressure sensor	M10x1	10 Nm (7.4 lbf ft)	–
Plug, cam lever axis	M10x1	15 Nm (11.1 lbf ft)	–
Plug, clutch lubrication	M10x1	10 Nm (7.4 lbf ft)	–
Screw plug, spreading transmission lock	M10x1	12 Nm (8.9 lbf ft)	–
Screw, conrod bearing	M10x1	Step 1 25 Nm (18.4 lbf ft) Step 2 30 Nm (22.1 lbf ft) Step 3 90°	–

Screw, timing chain tensioner release	M10x1	10 Nm (7.4 lbf ft)	–
Spark plug	M10x1	11 Nm (8.1 lbf ft)	–
Cylinder head screw	M11x1.5	Tightening sequence: Using a crisscross pattern Step 1 15 Nm (11.1 lbf ft) Step 2 30 Nm (22.1 lbf ft) Step 3 90° Step 4 90°	Lubricated with engine oil
Coolant temperature sensor	M12x1.5	12 Nm (8.9 lbf ft)	–
Rotor screw	M12x1.5	115 Nm (84.8 lbf ft)	–
Spark plug	M12x1.5	18 Nm (13.3 lbf ft)	–
Nut of engine sprocket	M20x1.5	100 Nm (73.8 lbf ft)	<b>Loctite® 243™</b>
Oil drain plug	M20x1.5	20 Nm (14.8 lbf ft)	–
Nut, inner clutch hub	M22x1.5	120 Nm (88.5 lbf ft)	<b>Loctite® 243™</b>
Plug, timing-chain tensioner	M24x1.5	25 Nm (18.4 lbf ft)	–
Screw in alternator cover	M24x1.5	8 Nm (5.9 lbf ft)	–
Nut, primary gear	M33LHx1.5	130 Nm (95.9 lbf ft)	<b>Loctite® 243™</b>

## 23.3 Capacities

### 23.3.1 Engine oil

Engine oil	3.50 l (3.7 qt.)	Outside temperature: $\geq 0\text{ }^{\circ}\text{C}$ ( $\geq 32\text{ }^{\circ}\text{F}$ )	Engine oil (SAE 10W/50)  p. 213
------------	------------------	--	---

Engine oil	3.50 l (3.7 qt.)	Outside temperature: < 0 °C (< 32 °F)	Engine oil (SAE 5W/40) (📖 p. 213)
------------	------------------	---------------------------------------	-----------------------------------

## 23.3.2 Coolant

Coolant	3.20 l (3.38 qt.)	Coolant (📖 p. 212)
---------	-------------------	--------------------

## 23.3.3 Fuel

Total fuel tank capacity, approx.	23 l (6.1 US gal)	Super unleaded (ROZ 95/RON 95/PON 91) (📖 p. 214)
-----------------------------------	-------------------	--

Fuel reserve, approx.	3.5 l (3.7 qt.)
-----------------------	-----------------

## 23.4 Chassis

Frame	Lattice frame made of chrome molybdenum steel tubing, powder-coated
Fork	<b>WP Performance Systems Semi-active Suspension</b>
Shock absorber	<b>WP Performance Systems Semi-active Suspension</b>
Suspension travel	
Front	125 mm (4.92 in)
Rear	156 mm (6.14 in)
Brake system	
Front	Double disc brake with radially mounted four-pot brake calipers, floating brake discs
Rear	Single disc brake with dual-piston brake caliper, fixed brake disc
Brake discs - diameter	
Front	320 mm (12.6 in)

Rear	240 mm (9.45 in)
Brake discs - wear limit	
Front	4.5 mm (0.177 in)
Brake discs - wear limit	
rear	4.5 mm (0.177 in)
Tire air pressure, solo/with passenger/full payload	
Front: with cold tires	2.5 bar (36 psi)
Rear: with cold tires	2.9 bar (42 psi)
Secondary drive ratio	17:38
Chain	5/8 x 5/16" (525) X-ring
Steering head angle	65.1°
Wheelbase	1,482 mm (58.35 in)
Seat height unloaded	835 mm (32.87 in)
Ground clearance unloaded	141 mm (5.55 in)
Weight without fuel approx.	213 kg (470 lb.)
Maximum permissible front axle load	165 kg (364 lb.)
Maximum permissible rear axle load	320 kg (705 lb.)
Maximum permissible overall weight	456 kg (1,005 lb.)

## 23.5 Electrical system

Battery	YTZ14S	Battery voltage: 12 V Nominal capacity: 11.2 Ah Maintenance-free
Fuse	58011109110	10 A
Fuse	58011109115	15 A

Fuse	58011109125	25 A
Fuse	58011109130	30 A
Low beam/high beam	H4/socket P43t	12 V 60/55 W
Parking light	LED	
Cornering light	LED	
Instrument lights and indicator lamps	LED	
Turn signal	LED	
Tail light	LED	
Brake light	LED	
License plate lamp	LED	

## 23.6 Tires

Front tires	Rear tires
<b>120/70 ZR 17 M/C (58W) TL</b> Pirelli Angel GT	<b>190/55 ZR 17 M/C (75W) TL (D)</b> Pirelli Angel GT
The tires specified represent one of the possible series production tires. Additional information is available in the Service section under: <a href="http://www.ktm.com">http://www.ktm.com</a>	

## 23.7 Fork

Fork article number	14.18.1Q.23
Fork	<b>WP Performance Systems Semi-active Suspension</b>
Spring length with preload spacer(s)	335 mm (13.19 in)
Spring rate	

Medium (standard)	20 N/mm (114 lb/in)	
Fork length	776 mm (30.55 in)	
Fork oil, fork leg, left	670 ml (22.65 fl. oz.)	Fork oil (SAE 4) (48601166S1) (📖 p. 214)
Fork oil, fork leg, right	410 ml (13.86 fl. oz.)	Fork oil (SAE 4) (48601166S1) (📖 p. 214)

## 23.8 Shock absorber

Shock absorber article number	01.18.1Q.23	
Shock absorber	<b>WP Performance Systems Semi-active Suspension</b>	
Spring rate		
Medium (standard)	185 N/mm (1,056 lb/in)	
Spring length	185 mm (7.28 in)	
Static sag	24 mm (0.94 in)	

## 23.9 Chassis tightening torques

Remaining screws, chassis	<b>EJOT PT®</b> K50x12	1 Nm (0.7 lbf ft)	–
Remaining screws, chassis	<b>EJOT PT®</b> K50x14	1 Nm (0.7 lbf ft)	–
Remaining screws, chassis	<b>EJOT PT®</b> K50x16	2 Nm (1.5 lbf ft)	–
Remaining screws, chassis	<b>EJOT PT®</b> K50x18	2 Nm (1.5 lbf ft)	–
Remaining screws, chassis	<b>EJOT PT®</b> K45x12	1 Nm (0.7 lbf ft)	–
Screw, air filter box lid	<b>EJOT PT®</b> K60	2 Nm (1.5 lbf ft)	–
Screw, tail light	<b>EJOT PT®</b> K50x14	2.5 Nm (1.84 lbf ft)	–
Screw, combination switch, left	M4	2.5 Nm (1.84 lbf ft)	–
Screw, exhaust valve cover	M4	4 Nm (3 lbf ft)	–



## 23 TECHNICAL DATA

Screw, side stand switch	M4	2 Nm (1.5 lbf ft)	–
Remaining nuts, chassis	M5	5 Nm (3.7 lbf ft)	–
Remaining screws, chassis	M5	5 Nm (3.7 lbf ft)	–
Screw, cable channel	M5	5 Nm (3.7 lbf ft)	–
Screw, chain sliding guard	M5	5 Nm (3.7 lbf ft)	–
Screw, combination switch, right	M5	3.5 Nm (2.58 lbf ft)	–
Screw, cornering light	M5	2 Nm (1.5 lbf ft)	–
Screw, cover part	M5	3.5 Nm (2.58 lbf ft)	–
Screw, filler cap	M5	3 Nm (2.2 lbf ft)	–
Screw, fuel level indicator	M5	3 Nm (2.2 lbf ft)	–
Screw, suspension travel sensor	M5x16	6 Nm (4.4 lbf ft)	–
Cable disk nut, exhaust valve control unit	M6	14 Nm (10.3 lbf ft)	–
Ground fitting on frame	M6	10 Nm (7.4 lbf ft)	–
Nut throttle cable valve control	M6	5 Nm (3.7 lbf ft)	–
Nut, ABS unit attachment	M6	8 Nm (5.9 lbf ft)	–
Nut, cable on starter motor	M6	4 Nm (3 lbf ft)	–
Remaining nuts, chassis	M6	10 Nm (7.4 lbf ft)	–
Remaining screws, chassis	M6	10 Nm (7.4 lbf ft)	–
Screw, ABS modulator on retaining bracket	M6	5 Nm (3.7 lbf ft)	–
Screw, ball joint of push rod on foot brake cylinder	M6	5 Nm (3.7 lbf ft)	<b>Loctite® 243™</b>
Screw, battery terminal	M6	4.5 Nm (3.32 lbf ft)	–
Screw, clutch assembly	M6	5 Nm (3.7 lbf ft)	<b>Loctite® 243™</b>

Screw, connecting piece, rear brake line	M6	10 Nm (7.4 lbf ft)	Loctite® 243™
Screw, cooler retaining bracket	M6	7 Nm (5.2 lbf ft)	–
Screw, exhaust clamp on main silencer	M6	8 Nm (5.9 lbf ft)	–
Screw, exhaust clamp on manifold	M6	8 Nm (5.9 lbf ft)	–
Screw, foot brake cylinder	M6	10 Nm (7.4 lbf ft)	Loctite® 243™
Screw, fuel pump	M6	6 Nm (4.4 lbf ft)	–
Screw, license plate holder on lower rear panel	M6	12 Nm (8.9 lbf ft)	–
Screw, radiator hose clamp	M6	3 Nm (2.2 lbf ft)	–
Screw, sensor box	M6	6 Nm (4.4 lbf ft)	Loctite® 243™
Screw, shift lever stub	M6	10 Nm (7.4 lbf ft)	Loctite® 243™
Screw, shift rod	M6	5 Nm (3.7 lbf ft)	Loctite® 243™
Screw, shift shaft deflector on shift shaft	M6	18 Nm (13.3 lbf ft)	Loctite® 243™
Screw, side stand stub	M6	6 Nm (4.4 lbf ft)	Loctite® 243™
Screw, side stand stub extension	M6	6 Nm (4.4 lbf ft)	Loctite® 243™
Screw, steering damper, holder, on frame	M6	8 Nm (5.9 lbf ft)	Loctite® 243™
Screw, step plate for foot brake lever	M6	10 Nm (7.4 lbf ft)	Loctite® 243™
Screw, suitcase molds	M6	6 Nm (4.4 lbf ft)	–
Screw, tire pressure sensor (Super Duke GT EU, Super Duke GT CN)	M6	7 Nm (5.2 lbf ft)	–
Screw, wheel speed sensor, front	M6	4 Nm (3 lbf ft)	–
Screw, wheel speed sensor, rear	M6	4 Nm (3 lbf ft)	–
Cable disk nut, exhaust valve	M8	7 Nm (5.2 lbf ft)	–

Nut, manifold on cylinder head	M8	Tightening sequence: Tighten the nuts evenly. Do not warp the metal plate. 25 Nm (18.4 lbf ft)	–
Nut, rear sprocket	M8	36 Nm (26.6 lbf ft)	–
Nut, shift rod	M8	12 Nm (8.9 lbf ft)	–
Nut, shift rod	M8LH	12 Nm (8.9 lbf ft)	–
Nut, valve, angled (Super Duke GT JP)	M8	4 Nm (3 lbf ft)	–
Nut, valve, angled (Super Duke GT EU, Super Duke GT CN)	M8	6 Nm (4.4 lbf ft)	–
Remaining nuts, chassis	M8	25 Nm (18.4 lbf ft)	–
Remaining screws, chassis	M8	25 Nm (18.4 lbf ft)	–
Screw, axle clamp	M8	15 Nm (11.1 lbf ft)	–
Screw, bottom triple clamp	M8	15 Nm (11.1 lbf ft)	–
Screw, foot brake lever	M8	20 Nm (14.8 lbf ft)	<b>Loctite® 243™</b>
Screw, front brake disc	M8	30 Nm (22.1 lbf ft)	<b>Loctite® 2701™</b>
Screw, front rider footrest bracket	M8	25 Nm (18.4 lbf ft)	<b>Loctite® 243™</b>
Screw, handlebar clamp	M8	20 Nm (14.8 lbf ft)	–
Screw, ignition lock (tamper-proof screw)	M8	25 Nm (18.4 lbf ft)	–
Screw, rear brake caliper	M8	25 Nm (18.4 lbf ft)	<b>Loctite® 2701™</b>
Screw, rear brake disc	M8	30 Nm (22.1 lbf ft)	<b>Loctite® 243™</b>
Screw, shift lever on footrest bracket	M8	20 Nm (14.8 lbf ft)	<b>Loctite® 243™</b>
Screw, shift shaft deflector on frame	M8	10 Nm (7.4 lbf ft)	<b>Loctite® 243™</b>
Screw, side stand bracket	M8	25 Nm (18.4 lbf ft)	<b>Loctite® 243™</b>
Screw, side stand spring	M8	15 Nm (11.1 lbf ft)	<b>Loctite® 2701™</b>

Screw, steering damper on holder	M8	8 Nm (5.9 lbf ft)	Loctite® 243™
Screw, steering damper on triple clamp	M8	8 Nm (5.9 lbf ft)	Loctite® 243™
Screw, steering stem clamp	M8	20 Nm (14.8 lbf ft)	Loctite® 243™
Screw, top triple clamp	M8	18 Nm (13.3 lbf ft)	–
Remaining nuts, chassis	M10	45 Nm (33.2 lbf ft)	–
Remaining screws, chassis	M10	45 Nm (33.2 lbf ft)	–
Screw, engine bearer	M10	45 Nm (33.2 lbf ft)	Loctite® 243™
Screw, front brake caliper	M10	45 Nm (33.2 lbf ft)	Loctite® 243™
Screw, handlebar support	M10	40 Nm (29.5 lbf ft)	Loctite® 243™
Screw, side stand	M10	35 Nm (25.8 lbf ft)	Loctite® 243™
Screw, side stand bracket	M10	45 Nm (33.2 lbf ft)	Loctite® 243™
Screw, side stand retaining plate	M10	45 Nm (33.2 lbf ft)	Loctite® 243™
Banjo bolt, brake line	M10x1	25 Nm (18.4 lbf ft)	–
Banjo bolt, brake line, connecting piece, rear	M10x1	15 Nm (11.1 lbf ft)	–
Nut, rear hub shock absorber carrier	M10x1.25	45 Nm (33.2 lbf ft)	Loctite® 243™
Lambda sensor	M12x1.25	25 Nm (18.4 lbf ft)	–
Screw, bottom shock absorber	M14x1.5	80 Nm (59 lbf ft)	Thread greased
Screw, top shock absorber	M14x1.5	80 Nm (59 lbf ft)	Thread greased
Screw, eccentric	M16	70 Nm (51.6 lbf ft)	–
Nut, swingarm pivot	M19x1.5	130 Nm (95.9 lbf ft)	Thread greased
Nut, seat lock	M22x1.5	6 Nm (4.4 lbf ft)	–
Bolt, front axle	M25x1.5	45 Nm (33.2 lbf ft)	Thread greased
Screw, steering head, top	M25x1.5	18 Nm (13.3 lbf ft)	–

## 23 TECHNICAL DATA

Nut, rear axle, shock absorber side	M35x1.5	200 Nm (147.5 lbf ft)	<b>Loctite® 262™</b> /lock the locking wire with locking varnish
Nut, rear axle	M50x1.5	250 Nm (184.4 lbf ft)	Thread greased/lock locking wire with locking varnish

## Brake fluid DOT 4 / DOT 5.1

### Standard/classification

- DOT

### Guideline

- Use only brake fluid that complies with the specified standard (see specifications on the container) and that exhibits the corresponding properties.

### Recommended supplier

#### Castrol

- **RESPONSE BRAKE FLUID SUPER DOT 4**

#### Motorex®

- **Brake Fluid DOT 5.1**

## Coolant

### Guideline

- Only use high-grade, silicate-free coolant with corrosion inhibitor additive for aluminum motors. Low grade and unsuitable antifreeze causes corrosion, deposits and frothing.
- Do not use pure water as only coolant is able to meet the requirements needed in terms of corrosion protection and lubrication properties.
- Only use coolant that complies with the requirements stated (see specifications on the container) and that has the relevant properties.

Antifreeze protection to at least	-25 °C (-13 °F)
-----------------------------------	-----------------

The mixture ratio must be adjusted to the necessary antifreeze protection. Use distilled water if the coolant needs to be diluted.

The use of premixed coolant is recommended.

Observe the coolant manufacturer specifications for antifreeze protection, dilution and miscibility (compatibility) with other coolants.

## Recommended supplier

Motorex®

- COOLANT M3.0

## Engine oil (SAE 10W/50)

### Standard/classification

- JASO T903 MA (📖 p. 217)
- SAE (📖 p. 217) (SAE 10W/50)

### Guideline

- Use only engine oils that comply with the specified standards (see specifications on the container) and that possess the corresponding properties.

Fully synthetic engine oil

## Recommended supplier

Motorex®

- Power Synt 4T

## Engine oil (SAE 5W/40)

### Standard/classification

- JASO T903 MA (📖 p. 217)
- SAE (📖 p. 217) (SAE 5W/40)

### Guideline

- Use only engine oils that comply with the specified standards (see specifications on the container) and that possess the corresponding properties.

Synthetic engine oil

## Recommended supplier

Motorex®

- Power Synt 4T

## Fork oil (SAE 4) (48601166S1)

### Standard/classification

- SAE (📖 p. 217) (SAE 4)

### Guideline

- Use only oils that comply with the specified standards (see specifications on the container) and that exhibit the corresponding properties.

## Super unleaded (ROZ 95/RON 95/PON 91)

### Standard/classification

- DIN EN 228 (ROZ 95/RON 95/PON 91)

### Guideline

- Only use unleaded super fuel that matches or is equivalent to the specified fuel grade.
- Fuel with an ethanol content of up to 10 % (E10 fuel) is safe to use.



### Info

Do **not** use fuel containing methanol (e. g. M15, M85, M100) or more than 10 % ethanol (e. g. E15, E25, E85, E100).

---



## Chain cleaner

Recommended supplier

Motorex®

- Chain Clean

## Chain lube for road use

Guideline

Recommended supplier

Motorex®

- Chainlube Road

## Fuel additive

Recommended supplier

Motorex®

- Fuel Stabilizer

## Long-life grease

Recommended supplier

Motorex®

- Bike Grease 2000

## Motorcycle cleaner

Recommended supplier

Motorex®

- Moto Clean

## Perfect Finish and high gloss polish for paints

Recommended supplier

Motorex®

- Moto Polish & Shine

## Preserving materials for paints, metal and rubber

Recommended supplier

Motorex®

- Moto Protect

## Special cleaner for glossy and matte paint finishes, metal and plastic surfaces

Recommended supplier

Motorex®

- Quick Cleaner

## Universal oil spray

Recommended supplier

Motorex®

- Joker 440 Synthetic

## JASO T903 MA

Different technical development directions required a separate specification for 4-stroke motorcycles – the **JASO T903 MA** standard. Earlier, engine oils from the automobile industry were used for 4-stroke motorcycles because there was no separate motorcycle specification.

Whereas long service intervals are demanded for automobile engines, the focus for motorcycle engines is on high performance at high engine speeds.

In most motorcycle engines, the transmission and the clutch are lubricated with the same oil.

The **JASO MA** standard meets these special requirements.

## SAE

The SAE viscosity classes were defined by the Society of Automotive Engineers and are used for classifying oils according to their viscosity. The viscosity describes only one property of oil and says nothing about quality.



ABS	ABS	Safety system that prevents locking of the wheels when driving straight ahead without the influence of lateral forces
ATIR	Automatic Turn Indicator Reset	Software, which automatically switches the indicator off according to a time or travel distance counter
DRL	Daytime Running Light	Light, which enhances the visibility of the vehicle during the day but is not focused, and in contrast to low beam does not illuminate the road surface
HHC	Hill Hold Control	Assist, which prevents the vehicle from rolling backwards on an incline
MSR	Motor Slip Regulation	Auxiliary function of the motor control, which prevents rear wheel locking with excessive engine braking effect, by lightly opening the throttle valve
MSC	Motorcycle Stability Control	The is an auxiliary function for the ABS, which can prevent blocking and slipping of the wheels during braking on an inclined position, within the physical limitations
MTC	Motorcycle Traction Control	Auxiliary function of the motor control, which reduces engine torque with spinning rear wheel
TPMS	Tire Pressure Monitoring System	Safety system, which monitors tire air pressure, with the help of sensors in the tire, and displays it to the rider

## 28 LIST OF ABBREVIATIONS

Art. no.	Article number
ca.	circa
cf.	compare
e.g.	for example
etc.	et cetera
i.a.	inter alia
no.	number
poss.	possibly





## 29.1 Red symbols

Red symbols indicate an error condition that requires immediate intervention.

	The immobilizer indicator lamp lights up/flashes red – Status or error message for immobilizer/alarm system.
	The oil pressure warning lamp lights up red – Engine oil pressure is too low.





## 29.2 Yellow and orange symbols

Yellow and orange symbols indicate an error condition that requires prompt intervention. Active driving aids are also represented by yellow or orange symbols.

	The general warning lamp lights up yellow – An operating safety (warning) message was detected. This is also shown on the matrix display.
	The engine warning lamp lights up/flashes yellow – The engine control unit has detected a fault.
	The ABS lamp lights up/flashes yellow – The ABS is not active. The ABS lamp also lights up if an error is detected.
	The TC lamp lights up/flashes yellow – The motorcycle traction control is not enabled or is currently intervening. The TC lamp also lights up if an error is detected. In addition, the TC lamp flashes if the <b>HHC</b> (optional) is active.
	The cruise control system lamp lights up yellow – The cruise control system function is switched on, but the speed control is not active.

## 29.3 Green and blue symbols

Green and blue symbols reflect information.

	The high beam indicator lamp lights up blue – The high beam is switched on.
	The left turn signal lamp flashes green simultaneously with the turn signal – The left turn signal is switched on.
	The idle indicator lamp lights up green – The transmission is in idle.
	The right turn signal lamp flashes with steady rhythmic flash – The right turn signal is switched on.
	The cruise control system lamp lights up green – The cruise control system function is switched on and the speed control is active.

## A

**ABS** ..... 127

### ACC1

front ..... 173

rear ..... 174

### ACC2

front ..... 173

rear ..... 174

**Accessories** ..... 15

**Antilock braking system** ..... 127

**Applying the brakes** ..... 90

**Auxiliary substances** ..... 15

## B

### Battery

installing ..... 152

recharging ..... 154

removing ..... 150

### Brake discs

checking ..... 129

### Brake fluid

front brake, adding ..... 131

rear brake, adding ..... 135

### Brake fluid level

front brake, checking ..... 130

rear brake, checking ..... 134

### Brake linings

front brake, checking ..... 133

rear brake, checking ..... 137

**Brake system** ..... 127-137

**Brakes** ..... 90

## C

### Capacity

Coolant ..... 203

engine oil ..... 185, 202-203

fuel ..... 96, 203

### Chain

checking ..... 116

cleaning ..... 112

dirt, checking for ..... 112

### Chain guide

checking ..... 116

### Chain tension

adjusting ..... 115

checking ..... 114

**Chassis number** ..... 22

### Clutch

fluid level, checking/correcting ..... 120

**Clutch lever** ..... 26

basic position, adjusting ..... 72

**Combination instrument** ..... 45-58, 60-67

"ABS" ..... 56



activation and test	45
"cLightTest"	66
"Clock/Date"	64
"Damping"	102
"Damping" menu	58
"Distance"	62
"Drive Mod"	58, 179
"DRL"	66
"Favorites"	51
"Fuel Cons"	64
"General Info"	53
"Heat Grip"	65
"Heating" menu	56
indicator lamps	47
"Language"	62
"load"	101
"Load" menu	57
matrix display	46
menu overview	60
message on the matrix display	48
"MTC"	56
overview	45
"Pressure"	63
"Quickshifter"	67
segment display	46
service display	51
"Set Favorites"	54
"Settings"	55
shift warning light	50
"Shift Light"	65
"Temp"	63
"TPMS"	53
"Trip 1"	52
"Trip 2"	52
"Warning"	55
<b>Combination switch</b>	
left side	27
overview left side	27
overview right	31
right	30
<b>Coolant level</b>	
checking in the compensating tank	175
correcting in the compensating tank	176
<b>Cornering headlight</b>	149
<b>Cornering light</b>	
light range, adjusting	166
setting, checking	163
<b>Cruise control system</b>	
lower button	34
switch	32
upper button	33
<b>Customer service</b>	16
<b>D</b>	
<b>Diagnostics connector</b>	173

# INDEX

224

## E

<b>Electric starter button</b> .....	35
<b>Emergency OFF switch</b> .....	31
<b>Engine</b>	
running in .....	78
<b>Engine braking control</b> .....	90
<b>Engine number</b> .....	23
<b>Engine oil</b>	
adding .....	187
changing .....	182
<b>Engine oil level</b>	
checking .....	181
<b>Engine sprocket</b>	
checking .....	116
<b>Environment</b> .....	13

## F

<b>Figures</b> .....	16
<b>Filler cap</b>	
closing .....	40
opening .....	38
<b>Foot brake lever</b> .....	44
basic position, adjusting .....	73
<b>Fork</b> .....	101
<b>Fork legs</b>	
dust boots, cleaning .....	126

<b>Fork part number</b> .....	24
-------------------------------	----

<b>Front fender</b>	
installing .....	125
removing .....	125

<b>Front rider's seat</b>	
mounting .....	108
removing .....	107

<b>Front wheel</b>	
installing .....	140
removing .....	138

<b>Fuel level display</b> .....	47
---------------------------------	----

<b>Fuses</b>	
in fuse box, changing .....	159

## G

<b>Grab handle</b> .....	42
--------------------------	----

## H

<b>Hand brake lever</b> .....	26
basic position, adjusting .....	72

<b>Handlebar position</b> .....	68
adjusting .....	68

<b>Hazard warning flasher</b> .....	28
-------------------------------------	----

<b>Hazard warning flasher switch</b> .....	28
--	----

<b>Headlight</b>	
Daytime running light .....	149
light range, adjusting .....	165
setting, checking .....	163

## Headlight bulb

changing . . . . . 162

**Horn button** . . . . . 30

## I

### Ignition key

activating/deactivating . . . . . 169

**Ignition lock** . . . . . 37

**Immobilizer** . . . . . 37

**Implied warranty** . . . . . 15

**Intended use** . . . . . 10

## K

**Key number** . . . . . 23

## L

**Light switch** . . . . . 28

**Luggage** . . . . . 79

## M

### Main fuse

changing . . . . . 158

### Main silencer

installing . . . . . 111

removing . . . . . 109

### Matrix display

menu . . . . . 51

**Misuse** . . . . . 10

## Motorcycle

cleaning . . . . . 190

lifting with front lifting gear . . . . . 104

lifting with rear lifting gear . . . . . 103

removing the rear from the lifting gear . . . . . 103

taking from the front lifting gear . . . . . 105

**Motorcycle traction control** . . . . . 179

**MSR** . . . . . 90

**MTC** . . . . . 179

## O

### Oil filter

changing . . . . . 182

### Oil screens

cleaning . . . . . 182

**Operating substances** . . . . . 15

**Owner's Manual** . . . . . 14

## P

**Parking** . . . . . 92

**Passenger footrests** . . . . . 42

### Passenger seat

mounting . . . . . 106

removing . . . . . 106

### Preparing for use

advice on first use . . . . . 77

after storage . . . . . 195

checks and maintenance measures when preparing for use . 81

**Protective clothing** ..... 13

## Q

**Quickshifter** ..... 85

## R

### Rear sprocket

checking ..... 116

### Rear wheel

installing ..... 144

removing ..... 142

### Refueling

fuel ..... 95

**Riding** ..... **85**

starting off ..... 83

starting off with **HHC** ..... 83

## S

**Safe operation** ..... 12

**Seat lock** ..... 41

**Service** ..... 16

**Service schedule** ..... 97-100

**Shift lever** ..... **43**

basic position, adjusting ..... 75

basic position, checking ..... 74

### Shift lever stub

setting ..... 76

**Shifting** ..... 85

**Shock absorber** ..... 101

**Shock absorber article number** ..... 24

**Side stand** ..... 44

**Socket for electrical accessories** ..... 36

**Spare parts** ..... 15

**Starting** ..... 82

### Steering

locking ..... 35

unlocking ..... 36

**Steering damper article number** ..... 25

**Steering lock** ..... 37

### Step plate of foot brake lever

setting ..... 74

**Stopping** ..... 92

**Storage** ..... 194

**Suspension setting** ..... 101-102

### Switch

on the left side of the handlebar ..... 27

on the right side of the handlebar ..... 30

## T

### Tank spoiler

installing ..... 123

removing ..... 122

### Technical data

capacities ..... 202

chassis ..... 203

chassis tightening torques ..... 206

electrical system ..... 204

engine	198-211
engine tightening torques	199
fork	205
shock absorber	206
tires	205
<b>Throttle grip</b>	27
<b>Tire air pressure</b>	
checking	147
<b>Tire condition</b>	
checking	145
<b>Tool set</b>	41
<b>Transport</b>	94
<b>Troubleshooting</b>	196-197
<b>Turn signal switch</b>	29
<b>Type label</b>	22
<b>U</b>	
<b>Use definition</b>	10
<b>V</b>	
<b>Vehicle</b>	
loading	79
<b>View of vehicle</b>	
front left	18
rear right	20
<b>W</b>	
<b>Warranty</b>	15

<b>Windshield</b>	
adjusting	70
installing	109
removing	108
<b>Winter operation</b>	
checks and maintenance steps	192
<b>Work rules</b>	13

**READY TO RACE**

[» www.ktm.com](http://www.ktm.com)



3213552en

09/2016

**KTM Sportmotorcycle GmbH**  
3230 Mattighofen/Austria  
<http://www.ktm.com>



Photo: Mitterbauer/KTM