

1290 Super Duke GT

Art. no. 3213610en



KTM

The work described in these setup instructions must be performed before the vehicle is delivered to the customer.

Read the setup instructions in their entirety before beginning work.

These setup instructions were written to correspond to the latest state of this series. We reserve the right to make changes in the interest of technical advancement without at the same time updating this manual.

We shall not provide a description of general workshop methods. Likewise, safety rules that apply in a workshop are not specified here. It is assumed that the work will be performed by a fully trained mechanic.

All specifications are non-binding. KTM Sportmotorcycle GmbH specifically reserves the right to modify or delete technical specifications, prices, colors, forms, materials, services, designs, equipment, etc., without prior notice and without specifying reasons, to adapt these to local conditions, as well as to stop production of a particular model without prior notice. KTM accepts no liability for delivery options, deviations from illustrations and descriptions, misprints, and other errors. The models portrayed partly contain special equipment that does not belong to the regular scope of supply.

© 2016 KTM Sportmotorcycle GmbH, Mattighofen Austria

All rights reserved

Reproduction, even in part, as well as copying of all kinds, is permitted only with the express written permission of the copyright owner.



ISO 9001(12 100 6061)

According to the international quality management standard ISO 9001, KTM uses quality assurance processes that lead to the maximum possible quality of the products.

Issued by: TÜV Management Service

REG.NO. 12 100 6061

KTM Sportmotorcycle GmbH

5230 Mattighofen, Austria

This document is valid for the following models:

1290 Super Duke GT EU (F9903QF, F9903QE)

1290 Super Duke GT JP (F9986QE)

1290 Super Duke GT US (F9975QE, F9975QF)

1290 Super Duke GT CN (F9987QE)



1.1 Symbols used

The meaning of specific symbols is described below.



Indicates an expected reaction (e.g. of a work step or a function).



Indicates an unexpected reaction (e.g. of a work step or a function).



Indicates a page reference (more information is provided on the specified page).



Indicates information with more details or tips.



Indicates the result of a testing step.



Denotes a voltage measurement.



Denotes a current measurement.



Denotes a resistance measurement.

1.2 Formats used

The typographical formats used in this document are explained below.

Proprietary name	Identifies a proprietary name.
Name[®]	Identifies a protected name.
Brand[™]	Identifies a trademark.
<u>Underlined terms</u>	Refer to technical details of the vehicle or indicate technical terms, which are explained in the glossary.

2.1 Unpacking and setting up the vehicle



S01182-01



S01183-01



S01184-01



S01185-10

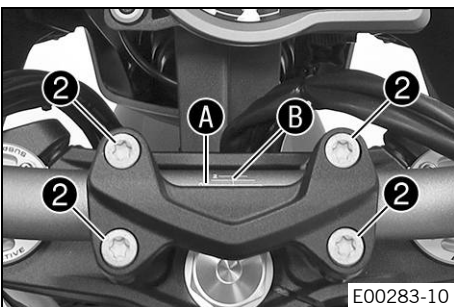

E00283-10

Preparatory work

- Remove the box.

Main work

- Remove the adhesive tape in the upper area of the motorcycle.

- Roll down the film at the sides.



Info

To avoid damaging the motorcycle during unpacking, leave the other films on the vehicle until you have finished work on the vehicle.

- Remove the separate enclosure and unpack it. Check the separate enclosure for completeness.
- Check the vehicle for transport damage.
- Remove the controls from the transport holder. Remove the screws of the handlebar clamp. Take off the handlebar clamp and transport holder.

- Remove right-hand handlebar weight **1**.
- Position the controls on the right half of the handlebar but do not tighten yet.



Warning

Danger of accidents A repaired handlebar poses a safety risk.

If the handlebar is bent or straightened, the material becomes fatigued. The handlebar may break as a result.

- Change the handlebar if the handlebar is damaged or bent.

- Position the handlebar.



Info

Make sure the cables and wiring are positioned correctly.

- Position the handlebar clamp. Mount screws **2** but do not tighten yet.
 - ✓ Marking **A** on the handlebar scale is aligned with the top edge of the handlebar clamp.
 - ✓ Center line **B** on the handlebar scale is aligned with the center of the handlebar clamp.

- First bolt the handlebar support with screws **2** onto the longer, higher side of the handlebar supports so that both parts touch.
- Tighten screws **2** evenly.

Guideline

Screw, handlebar clamp	M8	20 Nm (14.8 lbf ft)
------------------------	----	------------------------

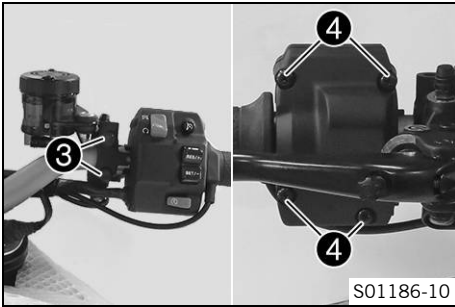

- Tighten screws **3** and **4** of the controls.

Guideline

Remaining screws, chassis	M6	10 Nm (7.4 lbf ft)
Screw, combination switch, right	M5	3.5 Nm (2.58 lbf ft)

- Mount right handlebar weight, tighten screw.

Guideline

Screw, handlebar weight	M6	10 Nm (7.4 lbf ft)
-------------------------	----	--------------------

- Check the throttle grip for smooth operation.
- Mount and tighten the rear mirror on both sides.

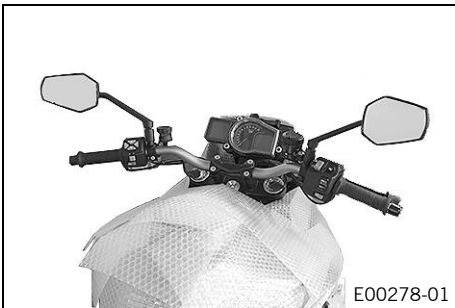

- Position windshield **5**.
- Mount and tighten screws **6**.

Guideline

Screw, windshield	M5	3.5 Nm (2.58 lbf ft)
-------------------	----	-------------------------

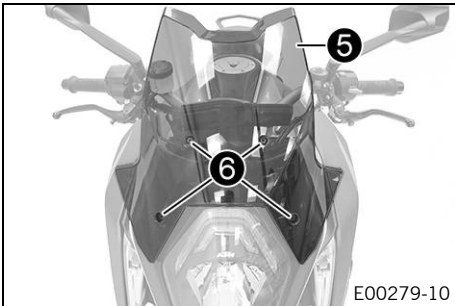

- Tape on the protective plastic sheet for the swingarm.
- Remove the cable ties of the rider footrests.

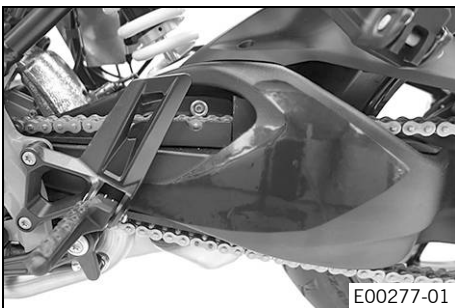

- Mount splash protector **7** with screws **8** on license plate holder **9**.

Guideline

Remaining screws, chassis	EJOT PT® K50x12	1 Nm (0.7 lbf ft)
---------------------------	-----------------	-------------------

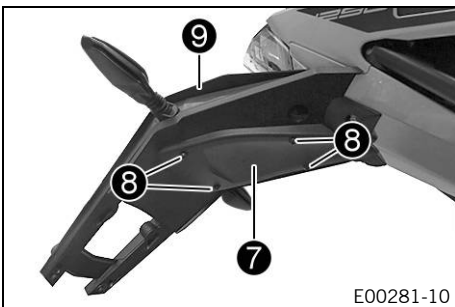

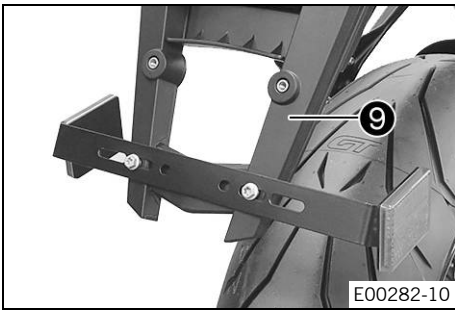

E00282-10

(Super Duke GT US)

- Bond the reflectors on the right and left side of the reflector holder.
- Mount the reflector holder on license plate holder 9.

Guideline

Remaining screws, chassis	M6	10 Nm (7.4 lbf ft)
---------------------------	----	-----------------------



E00273-01

- Remove the passenger seat. (📖 p. 7)
- Remove spare key and **KEYCODECARD** and keep in a safe place for the handover.
- Secure the tool set with the rubber holder.



E00274-01

- Carefully loosen and remove the tension belt from the frame.

i Info

An assistant prevents the motorcycle from falling over.

- Carefully loosen and remove the tension belts around the fork legs.
- ✓ The vehicle is released at the front.
- Together with an assistant, take the vehicle off the palette.
- Remove the radiator shield.

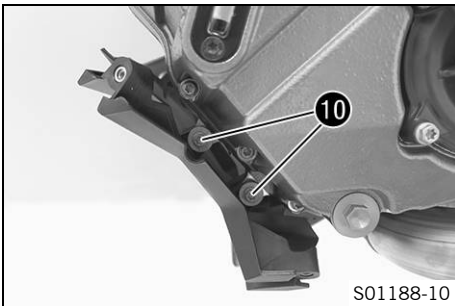

S01188-10

- Position the front spoiler. Mount and tighten screws 10 with the washers.

Guideline

Remaining screws, chassis	M6	10 Nm (7.4 lbf ft)
---------------------------	----	--------------------

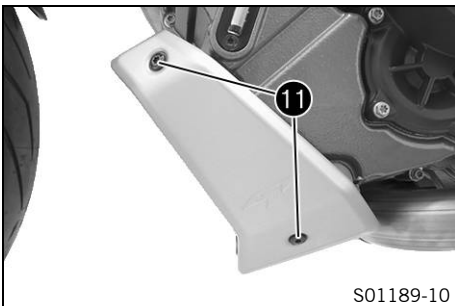

S01189-10

- Position metal sheets on the left and right. Mount and tighten screws 11.

Guideline

Remaining screws, chassis	M5	5 Nm (3.7 lbf ft)
---------------------------	----	-------------------

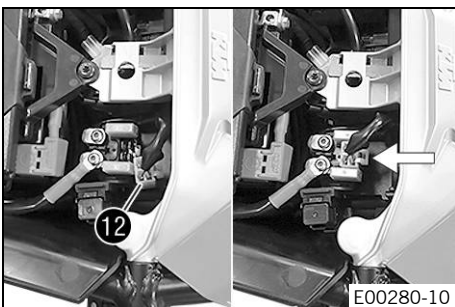

E00280-10

- Remove the front rider's seat. (📖 p. 7)
- Plug in the connector of starter relay 12.

(Super Duke GT US)

- Mount the side cases.

i Info

Observe the accompanying fitting instructions.

- Recharge the battery. (📖 p. 8)
- Remove the protective plastic.
- Refuel. (📖 p. 10)

- Prepare the vehicle according to the specifications in the **KTM Dealer.net** for handover to the customer.

3.1 Removing the passenger seat

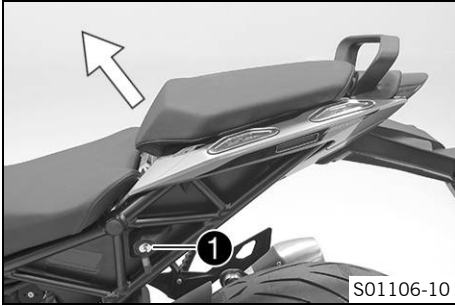

- Insert the ignition key in seat lock ❶ and turn it clockwise.
- Raise front of the passenger seat, pull toward the tank, and remove upward.
- Remove the ignition key.

3.2 Mounting the passenger seat

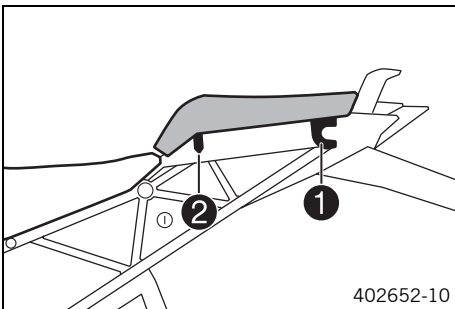

- Attach the hooks on the passenger seat to seat mounts ❶.
- Lower the passenger seat and push back.
- Position locking pin ❷ in the lock housing and push down the passenger seat at the front.
 - ✓ The locking pin engages with an audible click.
- Check that the passenger seat is correctly mounted.

3.3 Removing the front rider's seat

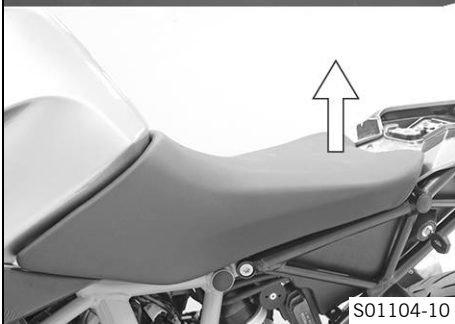
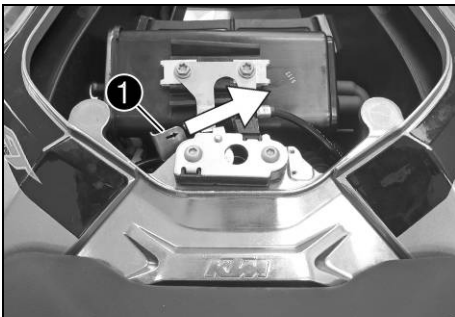

Preparatory work

- Remove the passenger seat. (📖 p. 7)

Main work

- Press seat release ❶ in the direction of the arrow and lift the front rider's seat at the rear at the same time.
- Detach the front of the front rider's seat and remove it.

3.4 Mounting the front rider's seat

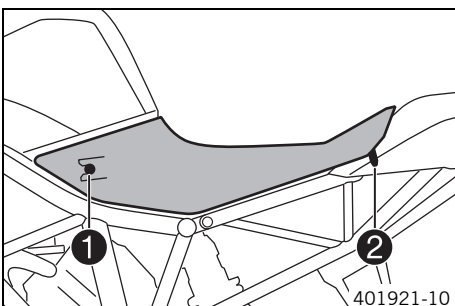

Main work

- Attach recesses ❶ on the front rider's seat to the fuel tank, push the front rider's seat forward.
- Position locking pin ❷ in the lock housing and push down the front rider's seat at the rear.
 - ✓ The locking pin engages with an audible click.
- Check that the front rider's seat is correctly mounted.

Finishing work

- Mount the passenger seat. (📖 p. 7)

3.5 Recharging the battery

- Warning**
Risk of injury Battery acid and battery gases cause serious chemical burns.
- Keep batteries out of the reach of children.
 - Wear suitable protective clothing and safety glasses.
 - Avoid contact with battery acid and battery gases.
 - Keep sparks or open flames away from the battery.
 - Only charge batteries in well-ventilated rooms.
 - Rinse the affected area immediately with plenty of water in the event of contact with the skin.
 - Rinse eyes with water for at least 15 minutes and consult a doctor immediately if battery acid and battery gases get into the eyes.

- Warning**
Environmental hazard Batteries contain environmentally-hazardous materials.
- Do not dispose of batteries as household waste.
 - Dispose of batteries at a collection point for used batteries.

- Warning**
Environmental hazard Hazardous substances cause environmental damage.
- Dispose of oils, grease, filters, fuel, cleaning agents, brake fluid, etc., correctly and in compliance with the applicable regulations.

i Info
 Even when there is no load on the battery, it discharges steadily.
 The charging level and the method of charging are very important for the service life of the battery.
 Rapid recharging with a high charging current shortens the service life of the battery.
 If the charging current, charging voltage, and charging time are exceeded, the battery will be destroyed.
 If the battery is depleted from starting the vehicle repeatedly, the battery must be charged immediately.
 If the battery is left in a discharged state for an extended period, it will become over-discharged and sulfated, destroying the battery.
 The battery is maintenance-free, i.e., the acid level does not have to be checked.

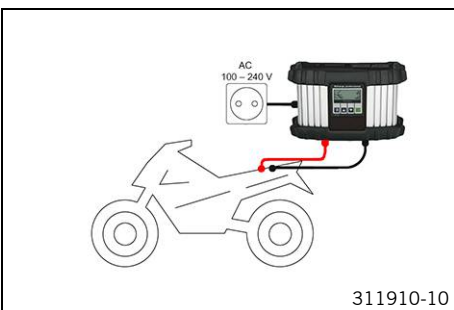

Preparatory work

- Switch off the ignition by turning the black ignition key to the position **OFF** ☒.
- Remove the passenger seat. (📖 p. 7)
- Remove the front rider's seat. (📖 p. 7)
- Disconnect the negative cable of the battery. (📖 p. 9)

Main work

- Connect the battery charger to the battery. Set the battery charger.

Alternative 1

Battery charger **XCharge-professional** EU (00029095050)

Alternative 2

Battery charger **XCharge-professional** US (00029095051)

Alternative 3

Battery charger **XCharge-professional** GB (00029095052)

Alternative 4

Battery charger **XCharge-professional** CH (00029095053)

i Info
 Follow the instructions of the charger and the manual.

- Disconnect the battery charger after charging the battery.

Guideline

The charging current, charging voltage, and charging time must not be exceeded.	
Charge the battery regularly when the motorcycle is not in use	3 months

Finishing work

- Connect the negative cable of the battery. (📖 p. 10)
- Mount the front rider's seat. (📖 p. 7)
- Mount the passenger seat. (📖 p. 7)
- Set the time and date.

3.6 Disconnecting the negative cable of the battery

Warning

Risk of injury Battery acid and battery gases cause serious chemical burns.

- Keep batteries out of the reach of children.
- Wear suitable protective clothing and safety glasses.
- Avoid contact with battery acid and battery gases.
- Keep sparks or open flames away from the battery.
- Only charge batteries in well-ventilated rooms.
- Rinse the affected area immediately with plenty of water in the event of contact with the skin.
- Rinse eyes with water for at least 15 minutes and consult a doctor immediately if battery acid and battery gases get into the eyes.

Caution

Danger of accidents Electronic components and safety devices will be damaged if the battery is discharged or missing.

- Never operate the vehicle with a discharged battery or without a battery.

Preparatory work

- Switch off the ignition by turning the black ignition key to the position **OFF** 🔌.
- Remove the passenger seat. (📖 p. 7)
- Remove the front rider's seat. (📖 p. 7)

Main work

- Remove screw ❶.
- Lift cover ❷ at the rear and pull toward the rear.
- Fold up the cover.

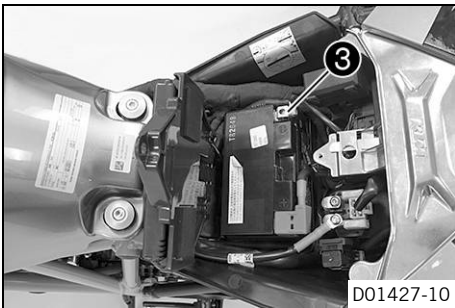
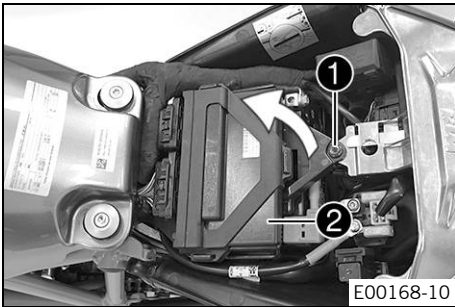

- Disconnect negative cable ❸ from the battery.

3.7 Connecting the negative cable of the battery

- Warning**
Risk of injury Battery acid and battery gases cause serious chemical burns.
- Keep batteries out of the reach of children.
 - Wear suitable protective clothing and safety glasses.
 - Avoid contact with battery acid and battery gases.
 - Keep sparks or open flames away from the battery.
 - Only charge batteries in well-ventilated rooms.
 - Rinse the affected area immediately with plenty of water in the event of contact with the skin.
 - Rinse eyes with water for at least 15 minutes and consult a doctor immediately if battery acid and battery gases get into the eyes.

- Caution**
Danger of accidents Electronic components and safety devices will be damaged if the battery is discharged or missing.
- Never operate the vehicle with a discharged battery or without a battery.

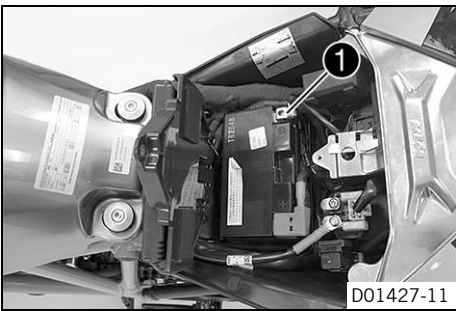

Main work

- Position negative cable ❶; mount and tighten the screw.

Guideline

Screw, battery terminal	M6	4.5 Nm (3.32 lbf ft)
-------------------------	----	-------------------------

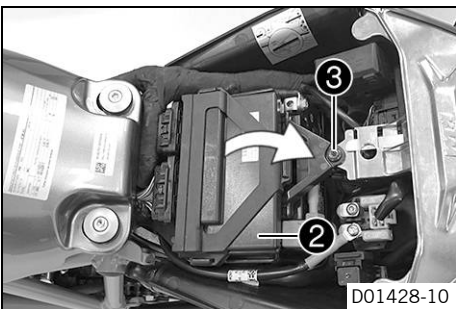

- Fold down cover ❷.
- Mount and tighten screw ❸.

Guideline

Remaining screws, chassis	M5	5 Nm (3.7 lbf ft)
---------------------------	----	-------------------

Finishing work

- Mount the front rider's seat. (📖 p. 7)
- Mount the passenger seat. (📖 p. 7)
- Set the time and date.

3.8 Refueling

- Danger**
Fire hazard Fuel is highly flammable.

The fuel in the fuel tank expands when warm and can escape if overfilled.

- Do not refuel the vehicle in the vicinity of open flames or lit cigarettes.
- Switch off the engine for refueling.
- Make sure that no fuel is spilled; particularly not on hot parts of the vehicle.
- If any fuel is spilled, wipe it off immediately.
- Observe the specifications for refueling.



Warning

Danger of poisoning Fuel is poisonous and a health hazard.

- Avoid skin, eye and clothing contact with fuel.
- Immediately consult a doctor if you swallow fuel.
- Do not inhale fuel vapors.
- In case of skin contact, rinse the affected area with plenty of water.
- Rinse the eyes thoroughly with water, and consult a doctor in case of fuel contact with the eyes.
- Change your clothing in case of fuel spills on them.

Note

Material damage Inadequate fuel quality causes the fuel filter to quickly become clogged.

In some countries and regions, the available fuel quality and cleanliness may not be sufficient. This will result in problems with the fuel system.

- Refuel only with clean fuel that meets the specified standards.



Warning

Environmental hazard Improper handling of fuel is a danger to the environment.

- Do not allow fuel to enter the groundwater, the soil, or the sewage system.

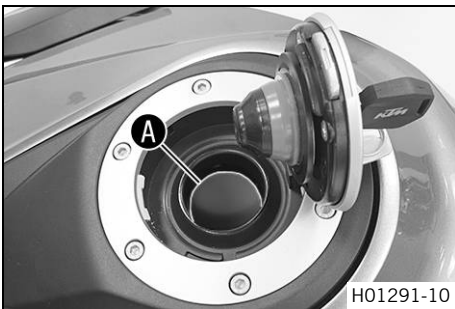

- Switch off the engine.
- Open the filler cap. (📖 p. 11)
- Fill the fuel tank with fuel up to the lower edge **A** of the filler neck.

Total fuel tank capacity, approx.	23 l (6.1 US gal)	Super unleaded (ROZ 95/RON 95/PON 91) (📖 p. 16)
-----------------------------------	-------------------	---

- Close the filler cap. (📖 p. 12)

3.9 Opening the filler cap



Danger

Fire hazard Fuel is highly flammable.

The fuel in the fuel tank expands when warm and can escape if overfilled.

- Do not refuel the vehicle in the vicinity of open flames or lit cigarettes.
- Switch off the engine for refueling.
- Make sure that no fuel is spilled; particularly not on hot parts of the vehicle.
- If any fuel is spilled, wipe it off immediately.
- Observe the specifications for refueling.



Warning

Danger of poisoning Fuel is poisonous and a health hazard.

- Avoid skin, eye and clothing contact with fuel.
- Immediately consult a doctor if you swallow fuel.
- Do not inhale fuel vapors.
- In case of skin contact, rinse the affected area with plenty of water.
- Rinse the eyes thoroughly with water, and consult a doctor in case of fuel contact with the eyes.
- Change your clothing in case of fuel spills on them.
- Keep fuels correctly in a suitable canister, and out of the reach of children.



Warning

Environmental hazard Improper handling of fuel is a danger to the environment.

- Do not allow fuel to enter the groundwater, the soil, or the sewage system.

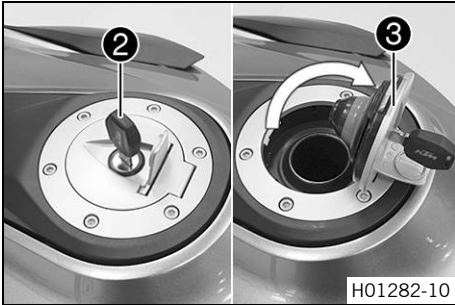
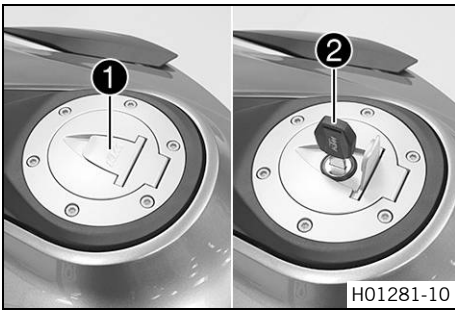

- Lift cover ① of the filler cap and insert ignition key ② in the fuel tank lock.

Note

Danger of damage The ignition key may break if overloaded. Damaged ignition keys must be replaced.

- Push down on the filler cap to take pressure off the ignition key.

- Turn ignition key ② clockwise.
- Fold open filler cap ③.

3.10 Closing the filler cap

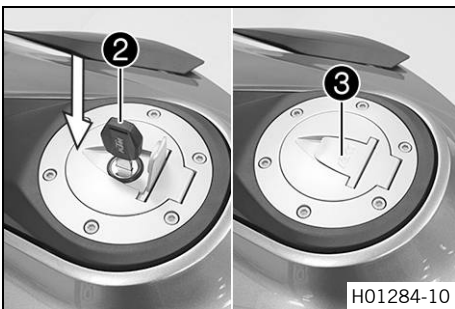
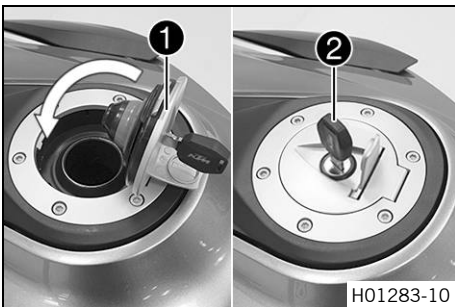

- Fold down filler cap ①.
- Turn ignition key ② clockwise.

- Press down the filler cap and turn back ignition key ② until the fuel tank lock locks.



Warning

Fire hazard Fuel is highly flammable, toxic and a health hazard.

- Check the filler cap is locked correctly after closing.
- Change your clothing in case of fuel spills on them.
- Rinse the affected area immediately with plenty of water in the event of contact with the skin.

- Remove ignition key ② and close cover ③.

3.11 "Clock/Date"

Clock/Date	
Hour	12
Minute	0
Day	1
Month	1
Year	2016

401990-02

Condition

- The vehicle is stationary.
- Press the **UP** or **DOWN** button until the **"Settings"** menu appears on the matrix display. Pressing the **SET** button opens the menu.
- Press the **UP** or **DOWN** button until **"Clock/Date"** is highlighted in black on the matrix display. Pressing the **SET** button again opens the menu.
- Use the **UP** or **DOWN** button to navigate through the menu. Use the **SET** button to set the time and date.

If the battery was disconnected from the vehicle, the time and date must be set in the matrix display.

4.1 Chassis tightening torques

Remaining screws, chassis	EJOT PT® K50x12	1 Nm (0.7 lbf ft)	–
Remaining screws, chassis	EJOT PT® K50x14	1 Nm (0.7 lbf ft)	–
Remaining screws, chassis	EJOT PT® K50x16	2 Nm (1.5 lbf ft)	–
Remaining screws, chassis	EJOT PT® K50x18	2 Nm (1.5 lbf ft)	–
Remaining screws, chassis	EJOT PT® K45x12	1 Nm (0.7 lbf ft)	–
Screw, air filter box lid	EJOT PT® K60	2 Nm (1.5 lbf ft)	–
Screw, tail light	EJOT PT® K50x14	2.5 Nm (1.84 lbf ft)	–
Screw, combination switch, left	M4	2.5 Nm (1.84 lbf ft)	–
Screw, exhaust valve cover	M4	4 Nm (3 lbf ft)	–
Screw, side stand switch	M4	2 Nm (1.5 lbf ft)	–
Remaining nuts, chassis	M5	5 Nm (3.7 lbf ft)	–
Remaining screws, chassis	M5	5 Nm (3.7 lbf ft)	–
Screw, cable channel	M5	5 Nm (3.7 lbf ft)	–
Screw, chain sliding guard	M5	5 Nm (3.7 lbf ft)	–
Screw, combination switch, right	M5	3.5 Nm (2.58 lbf ft)	–
Screw, cornering light	M5	2 Nm (1.5 lbf ft)	–
Screw, cover part	M5	3.5 Nm (2.58 lbf ft)	–
Screw, filler cap	M5	3 Nm (2.2 lbf ft)	–
Screw, fuel level indicator	M5	3 Nm (2.2 lbf ft)	–
Screw, suspension travel sensor	M5x16	6 Nm (4.4 lbf ft)	–
Cable disk nut, exhaust valve control unit	M6	14 Nm (10.3 lbf ft)	–
Ground fitting on frame	M6	10 Nm (7.4 lbf ft)	–
Nut throttle cable valve control	M6	5 Nm (3.7 lbf ft)	–
Nut, ABS unit attachment	M6	8 Nm (5.9 lbf ft)	–
Nut, cable on starter motor	M6	4 Nm (3 lbf ft)	–
Remaining nuts, chassis	M6	10 Nm (7.4 lbf ft)	–
Remaining screws, chassis	M6	10 Nm (7.4 lbf ft)	–
Screw, ABS modulator on retaining bracket	M6	5 Nm (3.7 lbf ft)	–
Screw, ball joint of push rod on foot brake cylinder	M6	5 Nm (3.7 lbf ft)	Loctite® 243™
Screw, battery terminal	M6	4.5 Nm (3.32 lbf ft)	–
Screw, clutch assembly	M6	5 Nm (3.7 lbf ft)	Loctite® 243™
Screw, connecting piece, rear brake line	M6	10 Nm (7.4 lbf ft)	Loctite® 243™
Screw, cooler retaining bracket	M6	7 Nm (5.2 lbf ft)	–
Screw, exhaust clamp on main silencer	M6	8 Nm (5.9 lbf ft)	–
Screw, exhaust clamp on manifold	M6	8 Nm (5.9 lbf ft)	–
Screw, foot brake cylinder	M6	10 Nm (7.4 lbf ft)	Loctite® 243™
Screw, fuel pump	M6	6 Nm (4.4 lbf ft)	–
Screw, license plate holder on lower rear panel	M6	12 Nm (8.9 lbf ft)	–
Screw, radiator hose clamp	M6	3 Nm (2.2 lbf ft)	–
Screw, sensor box	M6	6 Nm (4.4 lbf ft)	Loctite® 243™
Screw, shift lever stub	M6	10 Nm (7.4 lbf ft)	Loctite® 243™
Screw, shift rod	M6	5 Nm (3.7 lbf ft)	Loctite® 243™
Screw, shift shaft deflector on shift shaft	M6	18 Nm (13.3 lbf ft)	Loctite® 243™
Screw, side stand stub	M6	6 Nm (4.4 lbf ft)	Loctite® 243™
Screw, side stand stub extension	M6	6 Nm (4.4 lbf ft)	Loctite® 243™

Screw, steering damper, holder, on frame	M6	8 Nm (5.9 lbf ft)	Loctite® 243™
Screw, step plate for foot brake lever	M6	10 Nm (7.4 lbf ft)	Loctite® 243™
Screw, suitcase molds	M6	6 Nm (4.4 lbf ft)	–
Screw, tire pressure sensor (Super Duke GT EU/US/CN)	M6	7 Nm (5.2 lbf ft)	–
Screw, wheel speed sensor, front	M6	4 Nm (3 lbf ft)	–
Screw, wheel speed sensor, rear	M6	4 Nm (3 lbf ft)	–
Cable disk nut, exhaust valve	M8	7 Nm (5.2 lbf ft)	–
Nut, manifold on cylinder head	M8	Tightening sequence: Tighten the nuts evenly. Do not warp the metal plate. 25 Nm (18.4 lbf ft)	–
Nut, rear sprocket	M8	36 Nm (26.6 lbf ft)	–
Nut, shift rod	M8	12 Nm (8.9 lbf ft)	–
Nut, shift rod	M8LH	12 Nm (8.9 lbf ft)	–
Nut, valve, angled (Super Duke GT JP)	M8	4 Nm (3 lbf ft)	–
Nut, valve, angled (Super Duke GT EU/US/CN)	M8	6 Nm (4.4 lbf ft)	–
Remaining nuts, chassis	M8	25 Nm (18.4 lbf ft)	–
Remaining screws, chassis	M8	25 Nm (18.4 lbf ft)	–
Screw, axle clamp	M8	15 Nm (11.1 lbf ft)	–
Screw, bottom triple clamp	M8	15 Nm (11.1 lbf ft)	–
Screw, foot brake lever	M8	20 Nm (14.8 lbf ft)	Loctite® 243™
Screw, front brake disc	M8	30 Nm (22.1 lbf ft)	Loctite® 2701™
Screw, front rider footrest bracket	M8	25 Nm (18.4 lbf ft)	Loctite® 243™
Screw, handlebar clamp	M8	20 Nm (14.8 lbf ft)	–
Screw, ignition lock (tamper-proof screw)	M8	25 Nm (18.4 lbf ft)	–
Screw, rear brake caliper	M8	25 Nm (18.4 lbf ft)	Loctite® 2701™
Screw, rear brake disc	M8	30 Nm (22.1 lbf ft)	Loctite® 243™
Screw, shift lever on footrest bracket	M8	20 Nm (14.8 lbf ft)	Loctite® 243™
Screw, shift shaft deflector on frame	M8	10 Nm (7.4 lbf ft)	Loctite® 243™
Screw, side stand bracket	M8	25 Nm (18.4 lbf ft)	Loctite® 243™
Screw, side stand spring	M8	15 Nm (11.1 lbf ft)	Loctite® 2701™
Screw, steering damper on holder	M8	8 Nm (5.9 lbf ft)	Loctite® 243™
Screw, steering damper on triple clamp	M8	8 Nm (5.9 lbf ft)	Loctite® 243™
Screw, steering stem clamp	M8	20 Nm (14.8 lbf ft)	Loctite® 243™
Screw, top triple clamp	M8	18 Nm (13.3 lbf ft)	–
Remaining nuts, chassis	M10	45 Nm (33.2 lbf ft)	–
Remaining screws, chassis	M10	45 Nm (33.2 lbf ft)	–
Screw, engine bearer	M10	45 Nm (33.2 lbf ft)	Loctite® 243™
Screw, front brake caliper	M10	45 Nm (33.2 lbf ft)	Loctite® 243™
Screw, handlebar support	M10	40 Nm (29.5 lbf ft)	Loctite® 243™
Screw, side stand	M10	35 Nm (25.8 lbf ft)	Loctite® 243™
Screw, side stand bracket	M10	45 Nm (33.2 lbf ft)	Loctite® 243™
Screw, side stand retaining plate	M10	45 Nm (33.2 lbf ft)	Loctite® 243™
Banjo bolt, brake line	M10x1	25 Nm (18.4 lbf ft)	–
Banjo bolt, brake line, connecting piece, rear	M10x1	15 Nm (11.1 lbf ft)	–
Nut, rear hub shock absorber carrier	M10x1.25	45 Nm (33.2 lbf ft)	Loctite® 243™
Lambda sensor	M12x1.25	25 Nm (18.4 lbf ft)	–
Screw, bottom shock absorber	M14x1.5	80 Nm (59 lbf ft)	Thread greased
Screw, top shock absorber	M14x1.5	80 Nm (59 lbf ft)	Thread greased

Screw, eccentric	M16	70 Nm (51.6 lbf ft)	–
Nut, swingarm pivot	M19x1.5	130 Nm (95.9 lbf ft)	Thread greased
Nut, seat lock	M22x1.5	6 Nm (4.4 lbf ft)	–
Bolt, front axle	M25x1.5	45 Nm (33.2 lbf ft)	Thread greased
Screw, steering head, top	M25x1.5	18 Nm (13.3 lbf ft)	–
Nut, rear axle, shock absorber side	M35x1.5	200 Nm (147.5 lbf ft)	Loctite® 262™ /lock the locking wire with locking varnish
Nut, rear axle	M50x1.5	250 Nm (184.4 lbf ft)	Thread greased/lock locking wire with locking varnish

Super unleaded (ROZ 95/RON 95/PON 91)

Standard/classification

- DIN EN 228 (ROZ 95/RON 95/PON 91)

Guideline

- Only use unleaded super fuel that matches or is equivalent to the specified fuel grade.
- Fuel with an ethanol content of up to 10 % (E10 fuel) is safe to use.



Info

Do **not** use fuel containing methanol (e. g. M15, M85, M100) or more than 10 % ethanol (e. g. E15, E25, E85, E100).

READY TO RACE

>> www.ktm.com



3213610en

11/2016



KTM

KTM Sportmotorcycle GmbH
5230 Mattighofen/Austria
<http://www.ktm.com>



KTM Group Partner



REG. NO. 12 100 6061

Photo: Mitterbauer/KTM