

## 125 Duke

Art. no. 3213686en



**KTM**



Perform the work described in these setup instructions before the vehicle is delivered to the customer.

Read the setup instructions in their entirety before beginning work.

All specifications are non-binding. KTM Sportmotorcycle GmbH specifically reserves the right to modify or delete technical specifications, prices, colors, forms, materials, services, designs, equipment, etc., without prior notice and without specifying reasons, to adapt these to local conditions, as well as to stop production of a particular model without prior notice. KTM accepts no liability for delivery options, deviations from illustrations and descriptions, misprints, and other errors. The models portrayed partly contain special equipment that does not belong to the regular scope of supply.

These setup instructions were written to correspond to the latest state of this series. We reserve the right to make changes in the interest of technical advancement without at the same time updating this manual.

We shall not provide a description of general workshop methods. Likewise, safety rules that apply in a workshop are not specified here. It is assumed that the work will be performed by a fully trained mechanic.

© 2017 KTM Sportmotorcycle GmbH, Mattighofen Austria

All rights reserved

Reproduction, even in part, as well as copying of all kinds, is permitted only with the express written permission of the copyright owner.



ISO 9001(12 100 6061)

According to the international quality management standard ISO 9001, KTM uses quality assurance processes that lead to the maximum possible quality of the products.

Issued by: TÜV Management Service

REG.NO. 12 100 6061

KTM Sportmotorcycle GmbH  
5230 Mattighofen, Austria

This document is valid for the following models:

125 Duke EU (F4003Q1, F4003Q2, F4003Q3, F4003Q4)



## 1.1 Symbols used

The meaning of specific symbols is described below.



Indicates an expected reaction (e.g. of a work step or a function).



Indicates an unexpected reaction (e.g. of a work step or a function).



Indicates a page reference (more information is provided on the specified page).



Indicates information with more details or tips.



Indicates the result of a testing step.



Denotes a voltage measurement.



Denotes a current measurement.



Denotes a resistance measurement.

## 1.2 Formats used

The typographical formats used in this document are explained below.

<b>Proprietary name</b>	Identifies a proprietary name.
<b>Name<sup>®</sup></b>	Identifies a protected name.
<b>Brand<sup>™</sup></b>	Identifies a trademark.
<b><u>Underlined terms</u></b>	Refer to technical details of the vehicle or indicate technical terms, which are explained in the glossary.

## 2.1 Unpacking and setting up the vehicle

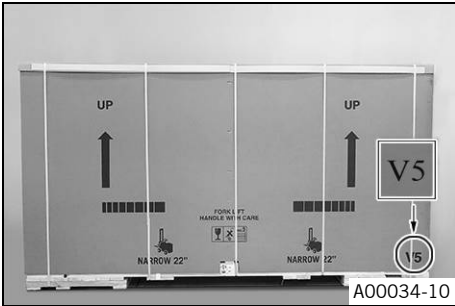

- Remove the straps and box.



- Remove the adhesive tape in the upper area of the motorcycle.



- Roll down the film at the sides.

**i Info**

To avoid damaging the motorcycle during unpacking, leave the other films on the vehicle until you have finished work on the vehicle.

- Remove the separate enclosure and unpack it. Check the separate enclosure for completeness.
- Check the vehicle for transport damage.



**! Warning**

**Danger of accidents** A repaired handlebar poses a safety risk. If the handlebar is bent or straightened, the material becomes fatigued. The handlebar may break as a result.

- Change the handlebar if the handlebar is damaged or bent.

- Position the handlebar.

**i Info**

Make sure the cables and wiring are positioned correctly.

- Position the handlebar clamp. Mount and tighten the screws evenly.

Guideline

Screw, handlebar clamp	M8	20 Nm (14.8 lbf ft)	Loctite® 243™
------------------------	----	------------------------	---------------

- ✓ The lettering on the handlebar is in the middle of the handlebar clamp.

- Position all controls in their exact positions on the handlebar. Tighten all screws.
- Check the clutch lever play. (📖 p. 5)
- Check the play in the throttle cable. (📖 p. 5)
- Mount and tighten the rear mirror on both sides.

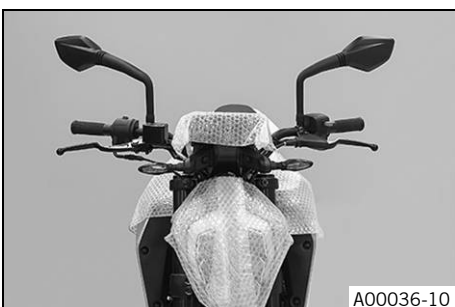

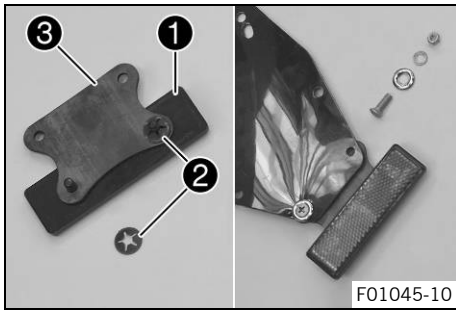

- Mount reflector ① with spring washers ② on holding plate ③.
- Mount the retaining plate on the license plate holder.
- Mount the license plate holder.
- Carefully loosen and remove the tension belt over the swingarm.



**Info**

An assistant prevents the motorcycle from falling over.

- Carefully loosen and remove the tension belts around the lower triple clamp.
- ✓ The vehicle is released at the front.
- Take the vehicle off the palette together with an assistant.
- Remove the front rider's seat. (📖 p. 6)
- Remove spare key and **KEYCODECARD** under the seat and keep in a safe place for the handover.



**Warning**

**Risk of injury** Battery acid and battery gases cause serious chemical burns.

- Keep batteries out of the reach of children.
- Wear suitable protective clothing and safety glasses.
- Avoid contact with battery acid and battery gases.
- Keep sparks or open flames away from the battery.
- Only charge batteries in well-ventilated rooms.
- Rinse the affected area immediately with plenty of water in the event of contact with the skin.
- Rinse eyes with water for at least 15 minutes and consult a doctor immediately if battery acid and battery gases get into the eyes.

- Fill the battery.



**Info**

Read the notes in the battery package.

- Recharge the battery. (📖 p. 7)
- Install the battery. (📖 p. 8)
- Remove the remaining films.
- Refuel. (📖 p. 10)
- Check the headlight setting. (📖 p. 11)
- Prepare the vehicle according to the specifications in the **KTM Dealer.net** for handover to the customer.

## 3.1 Checking the clutch lever play

**Note**

**Clutch damage** If there is no play on the clutch lever, the clutch will begin to slip.

- Check the play in the clutch lever on each occasion before operating the motorcycle.
- Adjust the play in the clutch lever when necessary in accordance with the specification.

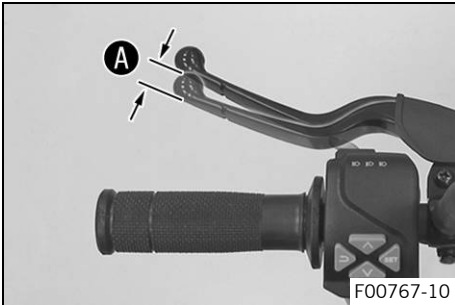

- Check the clutch lever for smooth operation.
- Move the handlebar to the straight-ahead position.
- Pull the clutch lever until resistance is perceptible, and determine the play in the clutch lever **A**.

Clutch lever play <b>A</b>	1... 3 mm (0.04... 0.12 in)
----------------------------	-----------------------------

- » If the clutch lever play does not meet the specified value:
  - Adjust play in the clutch lever. (🔧 p. 5)
- Move the handlebar to and fro over the entire steering range.

The clutch lever play must not change.
--

- » If the clutch lever play changes:
  - Check the routing of the clutch cable.

## 3.2 Adjusting play in the clutch lever

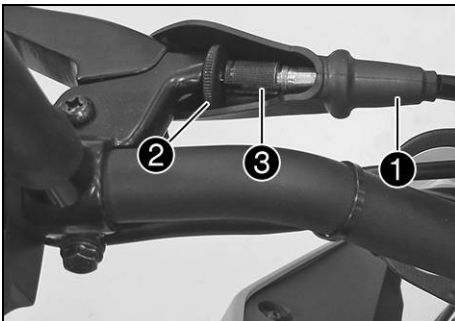

- Move the handlebar to the straight-ahead position.
- Push back sleeve **1**.
- Loosen lock nut **2**.
- Adjust the play in the clutch level **A** by turning adjusting screw **3**.

Guideline

Clutch lever play <b>A</b>	1... 3 mm (0.04... 0.12 in)
----------------------------	-----------------------------

- Tighten lock nut **2**.
- Position bellows **1**.

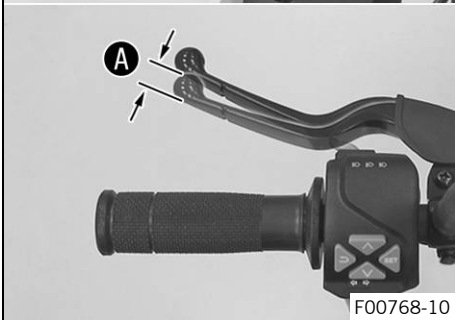

## 3.3 Checking the play in the throttle cable

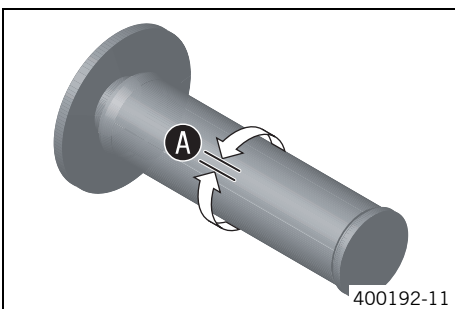

- Check the throttle grip for smooth operation.
- Move the handlebar to the straight-ahead position. Turn the throttle grip back and forth slightly and determine the play in throttle cable **A**.

Throttle cable play <b>A</b>	3... 5 mm (0.12... 0.2 in)
------------------------------	----------------------------

- » If the throttle cable play does not meet the specified value:
  - Adjust the play in the throttle cable. (🔧 p. 6)



**Danger**

**Danger of poisoning** Exhaust gases are toxic and inhaling them may result in unconsciousness and death.

- Always make sure there is sufficient ventilation when running the engine.
- Use an effective exhaust extraction system when starting or running the engine in an enclosed space.

- Start the engine and let it run idle. Move the handlebar to and fro over the entire steering range.

The idle speed must not change.

- » If the idle speed changes:
  - Check throttle cable routing.

### 3.4 Adjusting the play in the throttle cable

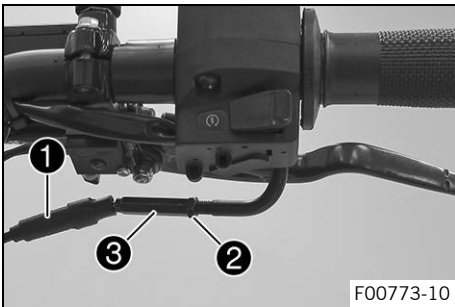

- Move the handlebar to the straight-ahead position.
- Push back sleeve ①.
- Loosen lock nut ②.
- Adjust the play in the throttle cable by turning adjusting screw ③.

Guideline

Throttle cable play	3... 5 mm (0.12... 0.2 in)
---------------------	----------------------------

- Tighten lock nut ②.
- Slide on sleeve ①.

### 3.5 Removing the passenger seat

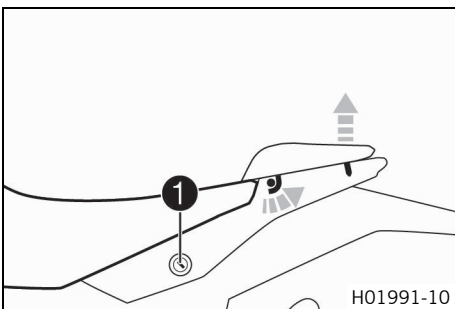

- Insert the ignition key in seat lock ① and turn it clockwise.
- Raise the rear of the seat, push it towards the rear, and remove it upwards.
- Remove the ignition key from the seat lock.

### 3.6 Mounting the passenger seat

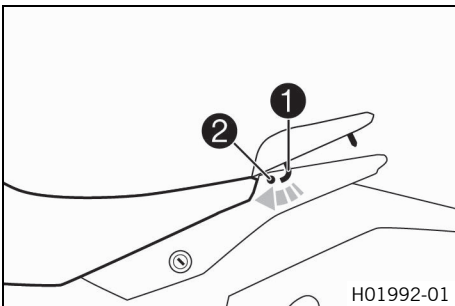

- Attach hooks ① on the passenger seat to seat mounting ② on the subframe, and lower it at the rear while pushing forward.
- Press down the passenger seat until it clicks into place.



**Warning**

**Danger of accidents** The passenger seat can come loose from the anchoring if it is not mounted correctly.

- After mounting the passenger seat, check that it is locked correctly by pulling up.

- Finally, check that the passenger seat is correctly mounted.

### 3.7 Removing the front rider's seat

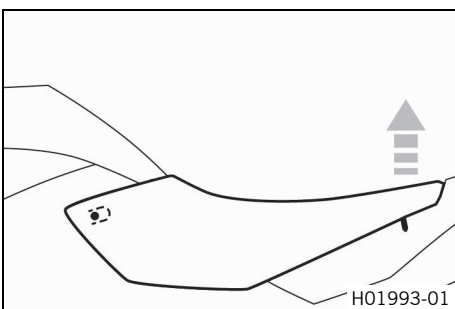

**Preparatory work**

- Remove the passenger seat. (📖 p. 6)

**Main work**

- Raise the rear of the front rider's seat, pull it towards the rear, and remove it upwards.

## 3.8 Mounting the front rider's seat

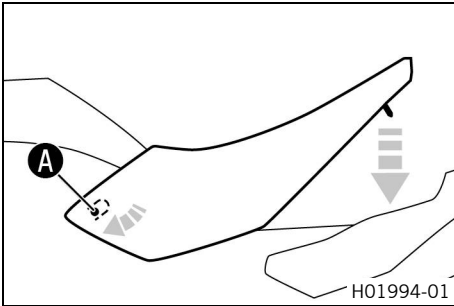

### Main work

- Attach the front rider's seat in area **A** and lower at the rear.
- Finally, check that the driver's seat is correctly mounted.

### Finishing work

- Mount the passenger seat. (📖 p. 6)

## 3.9 Recharging the battery



### Warning

**Risk of injury** Battery acid and battery gases cause serious chemical burns.

- Keep batteries out of the reach of children.
- Wear suitable protective clothing and safety glasses.
- Avoid contact with battery acid and battery gases.
- Keep sparks or open flames away from the battery.
- Only charge batteries in well-ventilated rooms.
- Rinse the affected area immediately with plenty of water in the event of contact with the skin.
- Rinse eyes with water for at least 15 minutes and consult a doctor immediately if battery acid and battery gases get into the eyes.



### Warning

**Environmental hazard** Batteries contain environmentally-hazardous materials.

- Do not dispose of batteries as household waste.
- Dispose of batteries at a collection point for used batteries.



### Warning

**Environmental hazard** Hazardous substances cause environmental damage.

- Dispose of oils, grease, filters, fuel, cleaning agents, brake fluid, etc., correctly and in compliance with the applicable regulations.



### Info

Even when there is no load on the battery, it discharges steadily.

The charging level and the method of charging are very important for the service life of the battery.

Rapid recharging with a high charging current shortens the service life of the battery.

If the charging current, charging voltage, and charging time are exceeded, the battery will be destroyed.

If the battery is depleted from starting the vehicle repeatedly, the battery must be charged immediately.

If the battery is left in a discharged state for an extended period, it will become over-discharged and sulfated, destroying the battery.

The battery is maintenance-free, i.e., the acid level does not have to be checked.

### Preparatory work

- Remove the passenger seat. (📖 p. 6)
- Remove the front rider's seat. (📖 p. 6)
- Disconnect the negative cable of the battery.

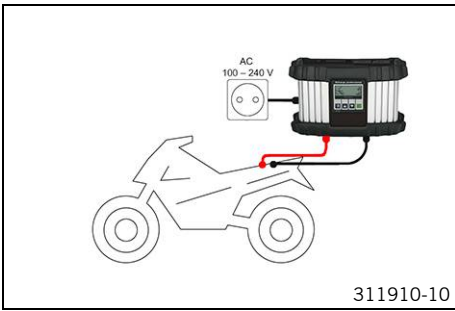

**Main work**

- Connect the battery charger to the battery. Set the battery charger.

**Alternative 1**

Battery charger **XCharge-professional** EU (00029095050)

**Alternative 2**

Battery charger **XCharge-professional** US (00029095051)

**Alternative 3**

Battery charger **XCharge-professional** GB (00029095052)

**Alternative 4**

Battery charger **XCharge-professional** CH (00029095053)



**Info**

Follow the instructions of the charger and the manual.

- Disconnect the battery charger after charging the battery.

**Guideline**

The charging current, charging voltage, and charging time must not be exceeded.	
Charge the battery regularly when the motorcycle is not in use	3 months

**Finishing work**

- Mount the front rider's seat. (📖 p. 7)
- Mount the passenger seat. (📖 p. 6)
- Set the time and date. (📖 p. 9)

## 3.10 Installing the battery

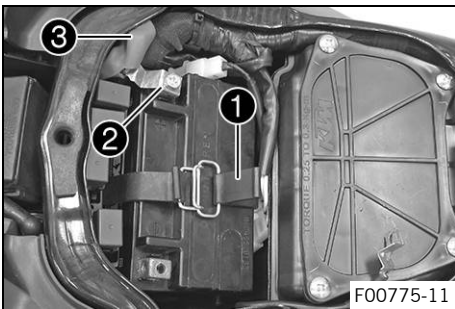

**Main work**

- Position the battery in the battery holder.

Battery (ETZ-9-BS)

- Reconnect rubber band **1**.
- Position positive cable **2** and mount and tighten the screw.
- Position positive terminal cover **3**.

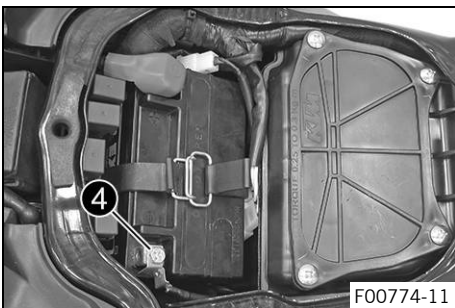

- Position negative cable **4**; mount and tighten the screw.

**Finishing work**

- Mount the front rider's seat. (📖 p. 7)
- Mount the passenger seat. (📖 p. 6)
- Set the time and date. (📖 p. 9)

## 3.11 Setting the time and date

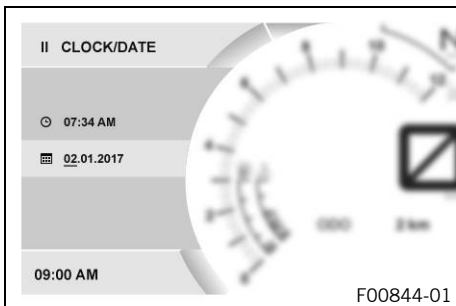
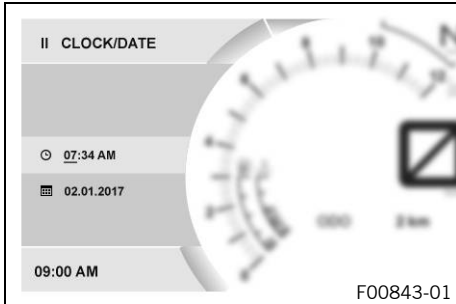
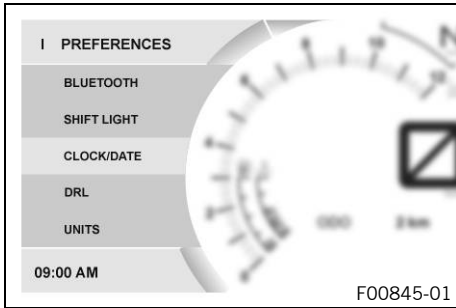
**Condition**

The motorcycle is stationary.

- Press the **SET** button when the menu is closed.
- Press the **UP** or **DOWN** button until **Preferences** appears. Press the **SET** button to open the menu.
- Press the **UP** or **DOWN** button until **Clock/Date** is marked. Press the **SET** button to open the menu.

**Setting the clock**

- Press the **UP** or **DOWN** button until the time is marked.
- Press the **SET** button.
  - ✓ The hour flashes and is underlined.
- Press the **UP** or **DOWN** button until the current hour is set.
- Press the **SET** button.
  - ✓ The minutes flash and are underlined.
- Press the **UP** or **DOWN** button until the current minute is set.
- Press the **SET** button.
  - ✓ The time is stored.

**Setting the date**

- Press the **UP** or **DOWN** button until the date is marked.
- Press the **SET** button.
  - ✓ The day flashes and is underlined.
- Press the **UP** or **DOWN** button until the current day is set.
- Press the **SET** button.
  - ✓ The month flashes and is underlined.
- Press the **UP** or **DOWN** button until the current month is set.
- Press the **SET** button.
  - ✓ The year flashes and is underlined.
- Press the **UP** or **DOWN** button until the current year is set.
- Press the **SET** button.
  - ✓ The date is stored.

## 3.12 Opening the filler cap

**Danger**

**Fire hazard** Fuel is highly flammable.

The fuel in the fuel tank expands when warm and can escape if overfilled.

- Do not refuel the vehicle in the vicinity of open flames or lit cigarettes.
- Switch off the engine for refueling.
- Make sure that no fuel is spilled; particularly not on hot parts of the vehicle.
- If any fuel is spilled, wipe it off immediately.
- Observe the specifications for refueling.



**Warning**

**Danger of poisoning** Fuel is poisonous and a health hazard.

- Avoid skin, eye and clothing contact with fuel.
- Immediately consult a doctor if you swallow fuel.
- Do not inhale fuel vapors.
- In case of skin contact, rinse the affected area with plenty of water.
- Rinse the eyes thoroughly with water, and consult a doctor in case of fuel contact with the eyes.
- Change your clothing in case of fuel spills on them.
- Keep fuels correctly in a suitable canister, and out of the reach of children.



**Warning**

**Environmental hazard** Improper handling of fuel is a danger to the environment.

- Do not allow fuel to enter the groundwater, the soil, or the sewage system.

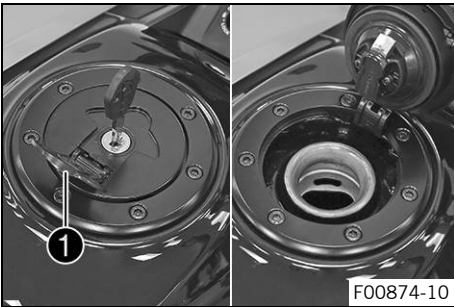

- Lift the cover **1** of the filler cap and insert the ignition key in the lock.

**Note**

**Danger of damage** The ignition key may break if overloaded. Damaged ignition keys must be replaced.

- Push down on the filler cap to take pressure off the ignition key.
- Turn the ignition key 90° clockwise.
- Open the filler cap.
- Remove the ignition key.

### 3.13 Closing the filler cap

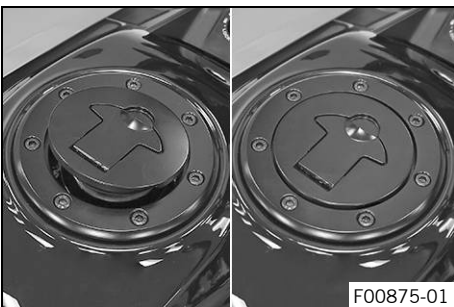

**Warning**

**Fire hazard** Fuel is highly flammable, toxic and a health hazard.

- Check the filler cap is locked correctly after closing.
- Change your clothing in case of fuel spills on them.
- Rinse the affected area immediately with plenty of water in the event of contact with the skin.

- Close the filler cap.
- Push down the filler cap until the lock engages.

### 3.14 Refueling



**Danger**

**Fire hazard** Fuel is highly flammable.

The fuel in the fuel tank expands when warm and can escape if overfilled.

- Do not refuel the vehicle in the vicinity of open flames or lit cigarettes.
- Switch off the engine for refueling.
- Make sure that no fuel is spilled; particularly not on hot parts of the vehicle.
- If any fuel is spilled, wipe it off immediately.
- Observe the specifications for refueling.



**Warning**

**Danger of poisoning** Fuel is poisonous and a health hazard.

- Avoid skin, eye and clothing contact with fuel.
- Immediately consult a doctor if you swallow fuel.
- Do not inhale fuel vapors.
- In case of skin contact, rinse the affected area with plenty of water.
- Rinse the eyes thoroughly with water, and consult a doctor in case of fuel contact with the eyes.
- Change your clothing in case of fuel spills on them.

**Note**

**Material damage** Inadequate fuel quality causes the fuel filter to quickly become clogged.

In some countries and regions, the available fuel quality and cleanliness may not be sufficient. This will result in problems with the fuel system.

- Refuel only with clean fuel that meets the specified standards.

**Warning**  
**Environmental hazard** Improper handling of fuel is a danger to the environment.

- Do not allow fuel to enter the groundwater, the soil, or the sewage system.

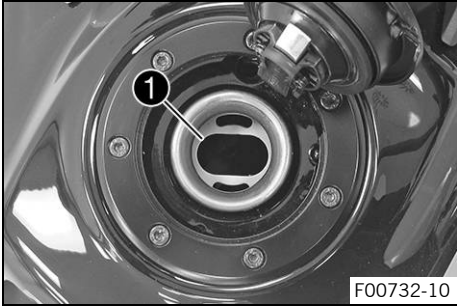

F00732-10

- Switch off the engine.
- Open the filler cap. (📖 p. 9)
- Fill the fuel tank with fuel up to the lower edge ① of the fuel filler.

Total fuel tank capacity, approx.	13.5 l (3.57 US gal)	Super unleaded (ROZ 95/RON 95/PON 91) (📖 p. 15)
-----------------------------------	-------------------------	---

- Close the filler cap. (📖 p. 10)

### 3.15 Checking the headlight setting

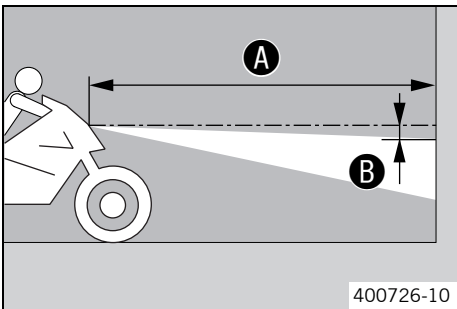

400726-10

- Position the vehicle upright on a horizontal surface in front of a light wall and make a mark at the height of the center of the low beam headlight.
- Make another mark at a distance ② under the first mark.

Guideline

Distance ②	5 cm (2 in)
------------	-------------

- Position the vehicle perpendicular to the wall at a distance ① from the wall and switch on the low beam.

Guideline

Distance ①	5 m (16 ft)
------------	-------------

- The rider, with luggage and passenger if applicable, now mounts the motorcycle.
- Check the headlight setting.

The light-dark boundary must lie exactly on the lower mark when the motorcycle is ready to operate with the rider mounted along with any luggage and a passenger if applicable.

- » If the boundary between light and dark does not meet specifications:
  - Adjust the headlight range. (📖 p. 11)

### 3.16 Adjusting the headlight range

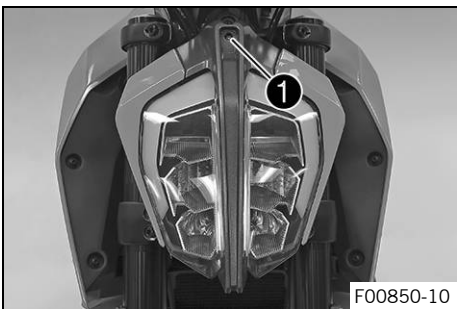

F00850-10

#### Preparatory work

- Check the headlight setting. (📖 p. 11)

#### Main work

- Turn adjusting screw ① to adjust the headlight range.

#### Info

Turn clockwise to increase the headlight range; turn counterclockwise to reduce the headlight range.

If you have a payload, you may have to correct the headlight range.

Screw ① also secures the headlight. Ensure the screw is always screwed in far enough.

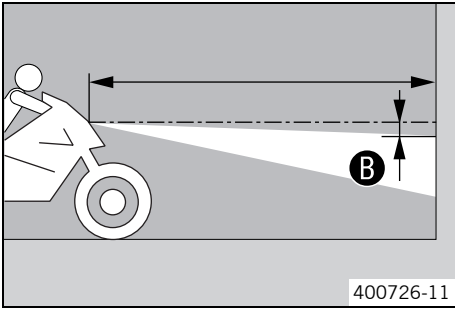

- Set the headlight to marking **B**.

Guideline

The light-dark boundary must lie exactly on lower mark **B** when the motorcycle is ready to operate with the rider mounted along with any luggage and a passenger if applicable.

## 4.1 Chassis tightening torques

Screw, chain guard	EJOT PT® K60x30	7 Nm (5.2 lbf ft)	–
Remaining screws, chassis	M4	4 Nm (3 lbf ft)	–
Remaining nuts, chassis	M5	5 Nm (3.7 lbf ft)	–
Remaining screws, chassis	M5	5 Nm (3.7 lbf ft)	–
Screw, chain guard	M5	7 Nm (5.2 lbf ft)	Loctite® 243™
Screw, compensating tank cap lock, rear brake	M5	9 Nm (6.6 lbf ft)	–
Screw, fuel tank cover	M5	4 Nm (3 lbf ft)	–
Screw, outer clutch cable guide	M5	5 Nm (3.7 lbf ft)	–
Screw, side stand switch	M5	5 Nm (3.7 lbf ft)	Loctite® 243™
Screw, tail light	M5	5 Nm (3.7 lbf ft)	–
Nut, foot brake lever adjustment	M6	9 Nm (6.6 lbf ft)	–
Remaining nuts, chassis	M6	10 Nm (7.4 lbf ft)	–
Remaining screws, chassis	M6	10 Nm (7.4 lbf ft)	–
Screw, ABS hose clamp	M6	7 Nm (5.2 lbf ft)	–
Screw, ABS module	M6	10 Nm (7.4 lbf ft)	–
Screw, ABS module retaining bracket on frame	M6	7 Nm (5.2 lbf ft)	–
Screw, air filter box	M6	6 Nm (4.4 lbf ft)	–
Screw, brake fluid reservoir of rear brake	M6	8 Nm (5.9 lbf ft)	–
Screw, brake hose clamp	M6	7 Nm (5.2 lbf ft)	–
Screw, cable holder, side stand switch	M6	9 Nm (6.6 lbf ft)	Loctite® 243™
Screw, chain sliding guard	M6	7 Nm (5.2 lbf ft)	–
Screw, combination instrument	M6	7 Nm (5.2 lbf ft)	–
Screw, compensating tank	M6	5 Nm (3.7 lbf ft)	–
Screw, damper block	M6	8 Nm (5.9 lbf ft)	–
Screw, engine sprocket cover	M6	8 Nm (5.9 lbf ft)	–
Screw, foot brake cylinder	M6	9 Nm (6.6 lbf ft)	Loctite® 243™
Screw, front fender	M6	7 Nm (5.2 lbf ft)	–
Screw, front seat fixing	M6	6 Nm (4.4 lbf ft)	–
Screw, front spoiler front	M6x13	9 Nm (6.6 lbf ft)	–
Screw, front spoiler rear	M6x9	9 Nm (6.6 lbf ft)	–
Screw, fuel pump	M6	10 Nm (7.4 lbf ft)	–
Screw, headlight	M6	8 Nm (5.9 lbf ft)	–
Screw, ignition coil	M6	8 Nm (5.9 lbf ft)	–
Screw, ignition lock (tamper-proof screw)	M6	13 Nm (9.6 lbf ft)	–
Screw, license plate holder	M6	12 Nm (8.9 lbf ft)	Loctite® 243™
Screw, lower rear panel	M6	7 Nm (5.2 lbf ft)	–
Screw, magnetic holder on side stand	M6	5 Nm (3.7 lbf ft)	Loctite® 243™
Screw, main silencer	M6	12 Nm (8.9 lbf ft)	–
Screw, main silencer retaining bracket	M6	9 Nm (6.6 lbf ft)	–
Screw, radiator holder	M6	10 Nm (7.4 lbf ft)	–
Screw, radiator shield	M6	7 Nm (5.2 lbf ft)	–
Screw, rear ABS sensor wheel	M6	8 Nm (5.9 lbf ft)	Loctite® 243™
Screw, rear splash protector	M6	9 Nm (6.6 lbf ft)	–
Screw, rollover sensor	M6	8 Nm (5.9 lbf ft)	–
Screw, shift lever linkage	M6	11 Nm (8.1 lbf ft)	Loctite® 243™
Screw, wheel speed sensor holder	M6	8 Nm (5.9 lbf ft)	–
Nut, rear sprocket	M8	27 Nm (19.9 lbf ft)	Loctite® 243™
Remaining nuts, chassis	M8	25 Nm (18.4 lbf ft)	–

Remaining screws, chassis	M8	25 Nm (18.4 lbf ft)	–
Screw, bottom triple clamp	M8	12 Nm (8.9 lbf ft)	–
Screw, engine bearer	M8	22 Nm (16.2 lbf ft)	–
Screw, foot brake lever	M8	16 Nm (11.8 lbf ft)	<b>Loctite® 243™</b>
Screw, fork stub	M8	15 Nm (11.1 lbf ft)	–
Screw, front brake caliper	M8	30 Nm (22.1 lbf ft)	<b>Loctite® 204™</b>
Screw, front brake disc	M8	30 Nm (22.1 lbf ft)	<b>Loctite® 243™</b>
Screw, front seat fixing	M8	20 Nm (14.8 lbf ft)	–
Screw, front wheel spindle	M8	25 Nm (18.4 lbf ft)	–
Screw, fuel tank	M8	20 Nm (14.8 lbf ft)	–
Screw, grab handle	M8	22 Nm (16.2 lbf ft)	–
Screw, handlebar clamp	M8	20 Nm (14.8 lbf ft)	<b>Loctite® 243™</b>
Screw, horn	M8	12 Nm (8.9 lbf ft)	–
Screw, lower rear panel	M8	15 Nm (11.1 lbf ft)	<b>Loctite® 243™</b>
Screw, main silencer	M8	23 Nm (17 lbf ft)	–
Screw, passenger footrest bracket	M8	22 Nm (16.2 lbf ft)	<b>Loctite® 243™</b>
Screw, rear brake disc	M8	21 Nm (15.5 lbf ft)	<b>Loctite® 243™</b>
Screw, rear frame	M8	25 Nm (18.4 lbf ft)	<b>Loctite® 243™</b>
Screw, rear seat fixing	M8	18 Nm (13.3 lbf ft)	–
Screw, seat support plate	M8	18 Nm (13.3 lbf ft)	–
Screw, top triple clamp	M8	15 Nm (11.1 lbf ft)	–
Banjo bolt, brake line	M10	24 Nm (17.7 lbf ft)	–
Fitting side stand	M10	35 Nm (25.8 lbf ft)	<b>Loctite® 243™</b>
Nut mirror image left	M10	16 Nm (11.8 lbf ft)	–
Remaining nuts, chassis	M10	45 Nm (33.2 lbf ft)	–
Remaining screws, chassis	M10	45 Nm (33.2 lbf ft)	–
Screw, engine bearer	M10	49 Nm (36.1 lbf ft)	<b>Loctite® 243™</b>
Fitting, handlebar support	M10x1.25	20 Nm (14.8 lbf ft)	–
Fitting, shock absorber, bottom	M10x1.25	51 Nm (37.6 lbf ft)	<b>Loctite® 243™</b>
Nut, mirror, right	M10LHx1.25	16 Nm (11.8 lbf ft)	–
Screw, combination instrument bracket	M10x1.25	21 Nm (15.5 lbf ft)	–
Screw, front footrest bracket	M10x1.25	44 Nm (32.5 lbf ft)	–
Screw, front footrest bracket / engine bearer	M10x1.25	49 Nm (36.1 lbf ft)	–
Screw, side stand bracket	M10x1.25	25 Nm (18.4 lbf ft)	<b>Loctite® 243™</b>
Screw, top shock absorber	M10x1.25	51 Nm (37.6 lbf ft)	<b>Loctite® 243™</b>
Stud, rear sprocket	M10x1.25	50 Nm (36.9 lbf ft)	–
Nut, rear wheel spindle	M14x1.5	98 Nm (72.3 lbf ft)	–
Nut, swingarm pivot	M14x1.5	98 Nm (72.3 lbf ft)	–
Screw, steering head, top	M16x1.5	49 Nm (36.1 lbf ft)	<b>Loctite® 243™</b>
Lambda sensor	M18x1.5	19 Nm (14 lbf ft)	–
Swingarm bearing adjusting ring	M22x1	Tighten and ensure that there is no play	–
Nut, steering head	M30x1	1st stage 45 Nm (33.2 lbf ft) 2nd stage (loosen, counter-clockwise) 2 turns 3rd stage 5 Nm (3.7 lbf ft)	–

## Super unleaded (ROZ 95/RON 95/PON 91)

### Standard/classification

- DIN EN 228 (ROZ 95/RON 95/PON 91)

### Guideline

- Only use unleaded super fuel that matches or is equivalent to the specified fuel grade.
- Fuel with an ethanol content of up to 10 % (E10 fuel) is safe to use.



### Info

Do **not** use fuel containing methanol (e. g. M15, M85, M100) or more than 10 % ethanol (e. g. E15, E25, E85, E100).



3213686en

03/2017

