

50 SX
50 SX Mini

Art. no. 3213670en



Perform the work described in these setup instructions before the vehicle is delivered to the customer.

Read the setup instructions in their entirety before beginning work.

These setup instructions were written to correspond to the latest state of this series. We reserve the right to make changes in the interest of technical advancement without at the same time updating this manual.

We shall not provide a description of general workshop methods. Likewise, safety rules that apply in a workshop are not specified here. It is assumed that the work will be performed by a fully trained mechanic.

All specifications are non-binding. KTM Sportmotorcycle GmbH specifically reserves the right to modify or delete technical specifications, prices, colors, forms, materials, services, designs, equipment, etc., without prior notice and without specifying reasons, to adapt these to local conditions, as well as to stop production of a particular model without prior notice. KTM accepts no liability for delivery options, deviations from illustrations and descriptions, misprints, and other errors. The models portrayed partly contain special equipment that does not belong to the regular scope of supply.

© 2017 KTM Sportmotorcycle GmbH, Mattighofen Austria

All rights reserved

Reproduction, even in part, as well as copying of all kinds, is permitted only with the express written permission of the copyright owner.



ISO 9001(12 100 6061)

According to the international quality management standard ISO 9001, KTM uses quality assurance processes that lead to the maximum possible quality of the products.

Issued by: TÜV Management Service

REG.NO. 12 100 6061

KTM Sportmotorcycle GmbH
5230 Mattighofen, Austria

This document is valid for the following models:

50 SX (F6001R4)

50 SX Mini (F6001R5)



1.1 Symbols used

The meaning of specific symbols is described below.



Indicates an expected reaction (e.g. of a work step or a function).



Indicates an unexpected reaction (e.g. of a work step or a function).



Indicates a page reference (more information is provided on the specified page).



Indicates information with more details or tips.



Indicates the result of a testing step.



Denotes a voltage measurement.



Denotes a current measurement.



Denotes a resistance measurement.

1.2 Formats used

The typographical formats used in this document are explained below.

Proprietary name	Identifies a proprietary name.
Name[®]	Identifies a protected name.
Brand[™]	Identifies a trademark.
<u>Underlined terms</u>	Refer to technical details of the vehicle or indicate technical terms, which are explained in the glossary.

2.1 Unpacking and setting up the vehicle



- Open the box.

i Info

To avoid damaging the vehicle while setting it up, do not remove the protective film on each component until installing the component, and leave it on the vehicle until work has been completed.

- Remove the separate enclosure and unpack it. Check that the scope of supply is complete using the enclosed packing list.
- Lift the vehicle out of the box with the assistance of another person.
- Raise the motorcycle with a lift stand. (🔧 p. 4)
- Check the vehicle for transport damage.
- Remove the protective film from the handlebar.
- Position the handlebar with handlebar clamps.
- Mount and tighten the screws.

Guideline

Screw, handlebar clamp	M8	20 Nm (14.8 lbf ft)
------------------------	----	------------------------

- Check the handlebar position.
 - » If the handlebar position is not adjusted as required by the customer:
 - Adjust the handlebar position. (🔧 p. 4)
- Remove the screw of the brake line guide. Position the brake line. Mount the brake line guide again and tighten the screw.
- Check that the controls on the handlebar are correctly positioned and firmly seated.
- Remove the seat. (🔧 p. 5)
- Remove the fuel tank. (🔧 p. 5)
- Position the service hour counter and fix it in place using an adhesive pad.
- Route the cable on the frame and attach it to the ignition wire.

i Info

Do not kink or damage the cable.

- Check that the wiring harness, throttle cables, and brake line have the necessary freedom of movement and are correctly routed.
- Install the fuel tank. (🔧 p. 6)
- Mount the seat. (🔧 p. 5)
- Mount the footrests with the springs and pins. Secure the pins using the washers and cotter pins.

Pliers for footrest spring (58429083000)

- Fill up with fuel. (🔧 p. 8)

(50 SX Mini)

- Fill up with oil. (🔧 p. 9)
- Remove the motorcycle from the lift stand. (🔧 p. 4)
- Rest the vehicle on the plug-in stand.
- Prepare the vehicle according to the specifications in the **KTM Dealer.net** for hand-over to the customer.

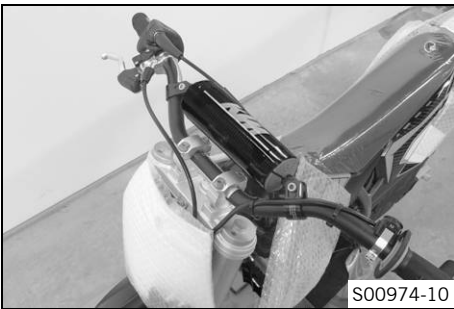

3.1 Raising the motorcycle with a lift stand

Note

Danger of damage The parked vehicle can roll away or fall over.

- Park the vehicle on a firm and level surface.

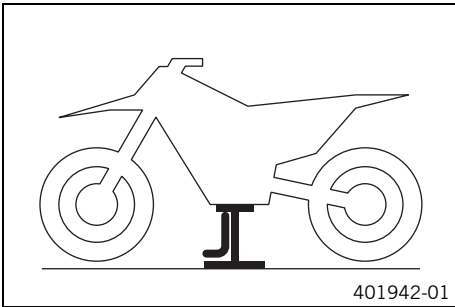

- Raise the motorcycle at the frame underneath the engine.

Lift stand (78929955100)

- ✓ Neither wheel is in contact with the ground.
- Secure the motorcycle against falling over.

3.2 Removing the motorcycle from the lift stand

Note

Danger of damage The parked vehicle can roll away or fall over.

- Park the vehicle on a firm and level surface.

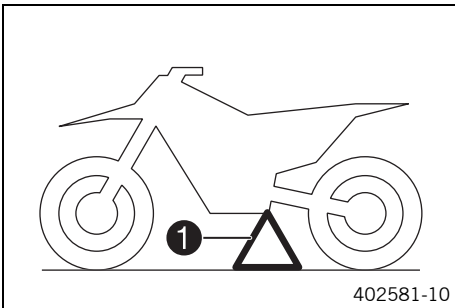

- Remove the motorcycle from the lift stand.
- Remove the lift stand.
- To park the motorcycle, insert plug-in stand ❶ into the plug-in stand bracket on the left side of the vehicle.

i Info

Remove the plug-in stand before riding.

3.3 Adjusting the handlebar position

Warning

Danger of accidents A repaired handlebar poses a safety risk.

If the handlebar is bent or straightened, the material becomes fatigued. The handlebar may break as a result.

- Change the handlebar if the handlebar is damaged or bent.

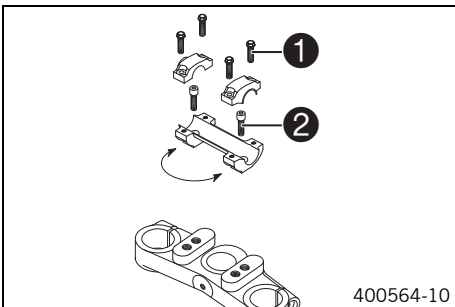

- Remove screws ❶. Take off the handlebar clamps. Remove the handlebar and lay it to one side.

i Info

Protect the motorcycle and its attachments against damage by covering them.
Do not kink the cables and lines.

- Remove screws ❷. Remove the handlebar support.
- Place the handlebar support in the required position. Mount and tighten screws ❷.

Guideline

Screw, handlebar support	M10	40 Nm (29.5 lbf ft)	Loctite® 243™
--------------------------	-----	------------------------	---------------

- Position the handlebar.

i Info

Make sure the cables and wiring are positioned correctly.

- Position the handlebar clamps. Mount screws ❶ and tighten evenly.

Guideline

Screw, handlebar clamp	M8	20 Nm (14.8 lbf ft)
------------------------	----	------------------------

i Info
Make sure the gap widths are even.

3.4 Removing the seat

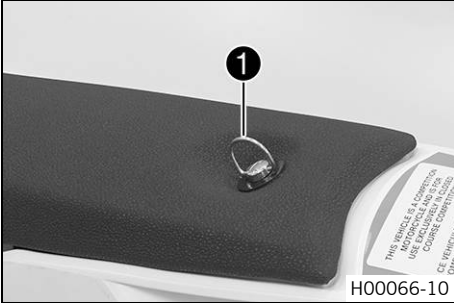

- Open quick release ❶ and raise the rear of the seat.
- Pull back the seat and remove it.

3.5 Mounting the seat

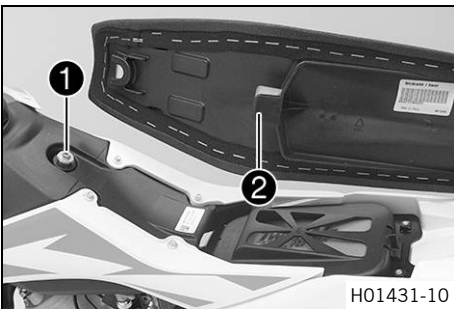

- Hook the seat onto screw ❶, lower the seat at the rear, and push it forward.
- ✓ Catch ❷ hooks into the fuel tank.

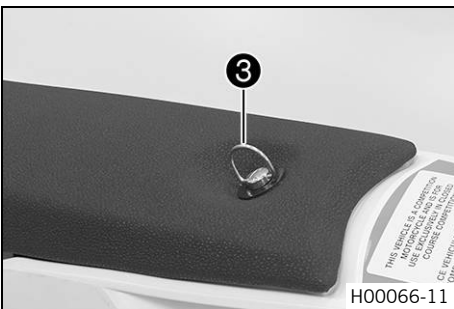

- Close quick release ❸.

3.6 Removing the fuel tank

! Danger
Fire hazard Fuel is highly flammable.

The fuel in the fuel tank expands when warm and can escape if overfilled.

- Do not refuel the vehicle in the vicinity of open flames or lit cigarettes.
- Switch off the engine for refueling.
- Make sure that no fuel is spilled; particularly not on hot parts of the vehicle.
- If any fuel is spilled, wipe it off immediately.
- Observe the specifications for refueling.



Warning

Danger of poisoning Fuel is poisonous and a health hazard.

- Avoid skin, eye and clothing contact with fuel.
- Immediately consult a doctor if you swallow fuel.
- Do not inhale fuel vapors.
- In case of skin contact, rinse the affected area with plenty of water.
- Rinse the eyes thoroughly with water, and consult a doctor in case of fuel contact with the eyes.
- Change your clothing in case of fuel spills on them.
- Keep fuels correctly in a suitable canister, and out of the reach of children.

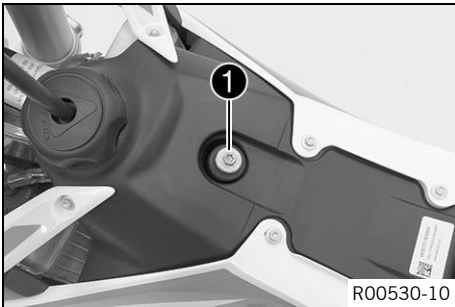

Preparatory work

- Remove the seat. (📖 p. 5)
- Turn the knurled screw on the fuel tap all the way clockwise.

Main work

- Remove screw ❶.

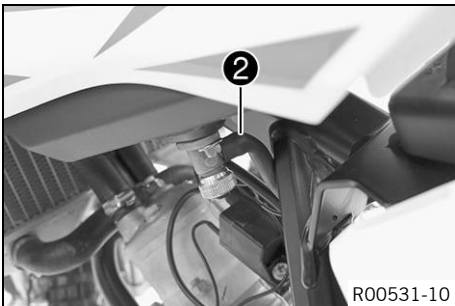

- Raise the fuel tank.
- Pull off fuel hose ❷.



Info

Remaining fuel may flow out of the fuel hose.

- Pull fuel tank breather out of the steering stem.
- Take off the fuel tank.

3.7 Installing the fuel tank



Danger

Fire hazard Fuel is highly flammable.

The fuel in the fuel tank expands when warm and can escape if overfilled.

- Do not refuel the vehicle in the vicinity of open flames or lit cigarettes.
- Switch off the engine for refueling.
- Make sure that no fuel is spilled; particularly not on hot parts of the vehicle.
- If any fuel is spilled, wipe it off immediately.
- Observe the specifications for refueling.



Warning

Danger of poisoning Fuel is poisonous and a health hazard.

- Avoid skin, eye and clothing contact with fuel.
- Immediately consult a doctor if you swallow fuel.
- Do not inhale fuel vapors.
- In case of skin contact, rinse the affected area with plenty of water.
- Rinse the eyes thoroughly with water, and consult a doctor in case of fuel contact with the eyes.
- Change your clothing in case of fuel spills on them.
- Keep fuels correctly in a suitable canister, and out of the reach of children.

Main work

- Check the throttle cable routing. (📖 p. 9)

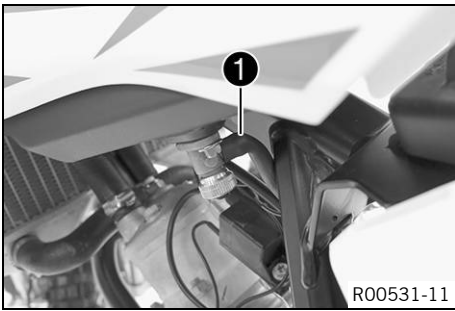

- Mount fuel hose ❶.

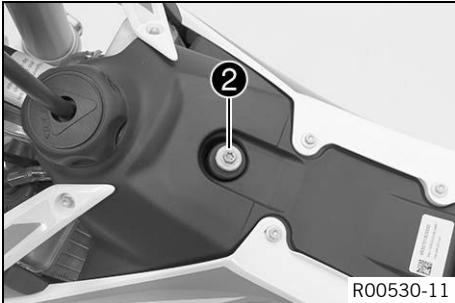

- Position the fuel tank.
- Make sure that no cables or throttle cables are trapped or damaged.
- Mount and tighten screw ❷.

Guideline

Remaining screws, chassis	M6	10 Nm (7.4 lbf ft)
---------------------------	----	--------------------

- Position the fuel tank breather in the steering stem.

Finishing work

- Mount the seat. (📖 p. 5)

3.8 Opening filler cap

Danger
Fire hazard Fuel is highly flammable.

The fuel in the fuel tank expands when warm and can escape if overfilled.

- Do not refuel the vehicle in the vicinity of open flames or lit cigarettes.
- Switch off the engine for refueling.
- Make sure that no fuel is spilled; particularly not on hot parts of the vehicle.
- If any fuel is spilled, wipe it off immediately.
- Observe the specifications for refueling.

Warning
Danger of poisoning Fuel is poisonous and a health hazard.

- Avoid skin, eye and clothing contact with fuel.
- Immediately consult a doctor if you swallow fuel.
- Do not inhale fuel vapors.
- In case of skin contact, rinse the affected area with plenty of water.
- Rinse the eyes thoroughly with water, and consult a doctor in case of fuel contact with the eyes.
- Change your clothing in case of fuel spills on them.
- Keep fuels correctly in a suitable canister, and out of the reach of children.

Warning
Environmental hazard Improper handling of fuel is a danger to the environment.

- Do not allow fuel to enter the groundwater, the soil, or the sewage system.



- Turn the tank cap ❶ counterclockwise and pull it up.

3.9 Closing the filler cap

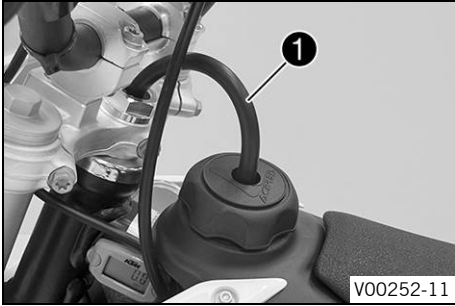

- Mount the filler cap and turn it clockwise until the fuel tank is firmly closed.



Info

Route fuel tank breather hose **1** without kinks.

3.10 Refueling



Danger

Fire hazard Fuel is highly flammable.

The fuel in the fuel tank expands when warm and can escape if overfilled.

- Do not refuel the vehicle in the vicinity of open flames or lit cigarettes.
- Switch off the engine for refueling.
- Make sure that no fuel is spilled; particularly not on hot parts of the vehicle.
- If any fuel is spilled, wipe it off immediately.
- Observe the specifications for refueling.



Warning

Danger of poisoning Fuel is poisonous and a health hazard.

- Avoid skin, eye and clothing contact with fuel.
- Immediately consult a doctor if you swallow fuel.
- Do not inhale fuel vapors.
- In case of skin contact, rinse the affected area with plenty of water.
- Rinse the eyes thoroughly with water, and consult a doctor in case of fuel contact with the eyes.
- Change your clothing in case of fuel spills on them.



Warning

Environmental hazard Improper handling of fuel is a danger to the environment.

- Do not allow fuel to enter the groundwater, the soil, or the sewage system.

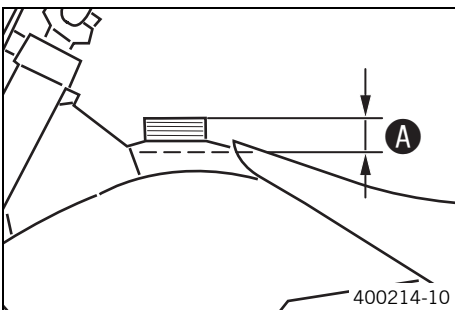

- Switch off the engine.
- Open the filler cap. (📖 p. 7)
- Fill the fuel tank with fuel up to measurement **A**.

Guideline

Measurement of A	35 mm (1.38 in)	
Fuel tank capacity, approx. (50 SX Mini)	2.1 l (2.2 qt.)	Super unleaded (ROZ 95/RON 95/PON 91) (📖 p. 12)
Fuel tank capacity, approx. (50 SX)	2.3 l (2.4 qt.)	Super unleaded (95 octane) mixed with 2-stroke engine oil (1:60) (📖 p. 12)

- Close the filler cap. (📖 p. 8)

3.11 Opening oil tank cap (50 SX Mini)

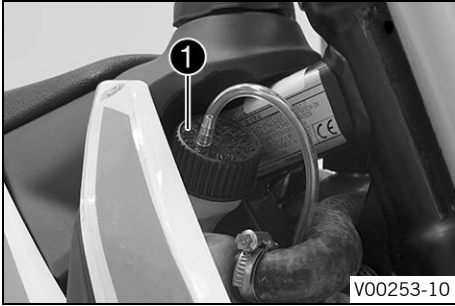

V00253-10

- Turn the oil tank cap ❶ counterclockwise and pull it up.

3.12 Closing oil tank cap (50 SX Mini)



V00253-11

- Put the oil tank cap on and turn it clockwise.



Info

Run the oil tank breather hose ❶ without kinks.

3.13 Filling up with oil (50 SX Mini)



Warning

Engine damage The engine will not be lubricated unless there is 2-stroke oil in the oil tank.

- For a full fuel tank, fill the oil tank at least up to the **MIN**mark.

- Switch off the engine.
- Open the oil tank cap. (📖 p. 9)
- Fill the oil tank at least up to the **MIN**mark ❶.

Guideline

MIN mark	Sufficient for a single tank filling	
Oil tank contents ca.	0.2 l (0.2 qt.)	Engine oil, 2-stroke (📖 p. 12)

- Close the oil tank cap. (📖 p. 9)

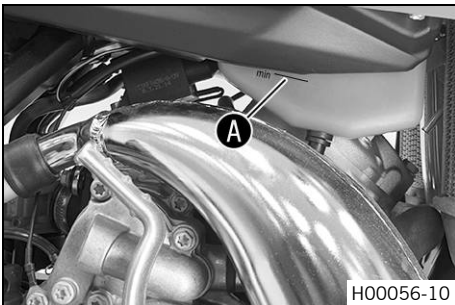

H00056-10

3.14 Checking the throttle cable routing



Warning

Danger of accidents The throttle cable may slip out of the guide if routed incorrectly. The throttle slide will then no longer be closed and the speed can no longer be controlled.

- Make sure that the throttle cable routing and the play in throttle cable complies with the specification.

Preparatory work

- Remove the seat. (📖 p. 5)
- Turn the knurled screw on the fuel tap all the way clockwise.
- Remove the fuel tank. (📖 p. 5)

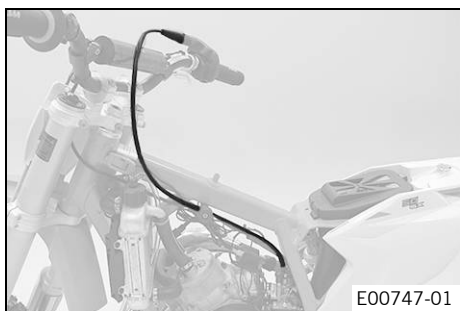

Main work

- Check the throttle cable routing.

The throttle cable must be routed to the carburetor behind the handlebars and above the fuel tank bracket.

- » If the throttle cable is not routed as specified:
 - Correct the throttle cable routing.

Finishing work

- Install the fuel tank. (📖 p. 6)
- Mount the seat. (📖 p. 5)

4.1 chassis tightening torques

Spoke nipple	M3.5	3 Nm (2.2 lbf ft)	–
Screw, brake linings	M5	8 Nm (5.9 lbf ft)	–
Nut, push rod ball joint on foot brake cylinder	M6	10 Nm (7.4 lbf ft)	–
Rear brake caliper screw	M6	10 Nm (7.4 lbf ft)	Loctite® 243™
Remaining nuts, chassis	M6	10 Nm (7.4 lbf ft)	–
Remaining screws, chassis	M6	10 Nm (7.4 lbf ft)	–
Screw, chain sliding piece	M6	3 Nm (2.2 lbf ft)	–
Screw, fender	M6	6 Nm (4.4 lbf ft)	–
Screw, fork stub	M6	10 Nm (7.4 lbf ft)	–
Screw, front brake disc	M6	14 Nm (10.3 lbf ft)	Loctite® 243™
Screw, rear brake disc	M6	14 Nm (10.3 lbf ft)	Loctite® 243™
Screw, start number plate	M6	4 Nm (3 lbf ft)	–
Screw, throttle grip	M6	4.5 Nm (3.32 lbf ft)	–
Nut, foot brake lever	M8	22 Nm (16.2 lbf ft)	–
Nut, rim lock	M8	10 Nm (7.4 lbf ft)	–
Remaining nuts, chassis	M8	25 Nm (18.4 lbf ft)	–
Remaining screws, chassis	M8	25 Nm (18.4 lbf ft)	–
Screw, bottom triple clamp	M8	15 Nm (11.1 lbf ft)	–
Screw, chain sliding piece	M8	15 Nm (11.1 lbf ft)	–
Screw, engine bracket	M8	25 Nm (18.4 lbf ft)	Loctite® 243™
Screw, front brake caliper	M8x60	20 Nm (14.8 lbf ft)	Loctite® 243™
Screw, handlebar clamp	M8	20 Nm (14.8 lbf ft)	–
Screw, rear sprocket	M8	25 Nm (18.4 lbf ft)	Loctite® 243™
Screw, top triple clamp	M8	20 Nm (14.8 lbf ft)	–
Nut, swingarm pivot	M10	45 Nm (33.2 lbf ft)	–
Remaining nuts, chassis	M10	45 Nm (33.2 lbf ft)	–
Remaining screws, chassis	M10	45 Nm (33.2 lbf ft)	–
Screw, bottom shock absorber	M10	45 Nm (33.2 lbf ft)	Loctite® 243™
Screw, front wheel spindle	M10	40 Nm (29.5 lbf ft)	Loctite® 243™
Screw, handlebar support	M10	40 Nm (29.5 lbf ft)	Loctite® 243™
Screw, top shock absorber	M10	45 Nm (33.2 lbf ft)	Loctite® 243™
Nut, rear wheel spindle	M12x1	40 Nm (29.5 lbf ft)	–
Nut, steering head	M20x1.5	10 Nm (7.4 lbf ft)	–
Nut, steering head	M20x1.5	9 Nm (6.6 lbf ft)	Only applies when using: Holding wrench for steering head bearing (45229050000)

Engine oil, 2-stroke

Standard/classification

- JASO FD (📖 p. 13)

Guideline

- Only use high grade 2-stroke engine oil of a reputable brand.

Fully synthetic

Recommended supplier

Motorex®

- Cross Power 2T

Super unleaded (ROZ 95/RON 95/PON 91)

Standard/classification

- DIN EN 228 (ROZ 95/RON 95/PON 91)

Guideline

- Only use unleaded super fuel that matches or is equivalent to the specified fuel grade.
- Fuel with an ethanol content of up to 10 % (E10 fuel) is safe to use.



Info

Do **not** use fuel containing methanol (e. g. M15, M85, M100) or more than 10 % ethanol (e. g. E15, E25, E85, E100).

Super unleaded (95 octane) mixed with 2-stroke engine oil (1:60)

Standard/classification

- DIN EN 228
- JASO FD (📖 p. 13) (1:60)

Mixture ratio

1:60	Engine oil, 2-stroke (📖 p. 12) Super unleaded (ROZ 95/RON 95/PON 91) (📖 p. 12)
------	---

Recommended supplier

Motorex®

- Cross Power 2T

JASO FD

JASO FD is a classification for a 2-stroke engine oil that was specifically developed for the extreme demands of racing. Thanks to first rate synthetic esters and specially designed additives, superb combustion is achieved even under extreme operating conditions.

READY TO RACE

>> www.ktm.com



3213670en

03/2017



KTM

KTM Sportmotorcycle GmbH
5230 Mattighofen/Austria
<http://www.ktm.com>



KTM Group Partner



REG. NO. 12 100 6061

Photo: Mitterbauer/KTM