

**125 XC-W**  
**150 XC-W**

Art. no. 3213704en



**KTM**



Perform the work described in these setup instructions before the vehicle is delivered to the customer.

Read the setup instructions in their entirety before beginning work.

These setup instructions were written to correspond to the latest state of this series. We reserve the right to make changes in the interest of technical advancement without at the same time updating this manual.

We shall not provide a description of general workshop methods. Likewise, safety rules that apply in a workshop are not specified here. It is assumed that the work will be performed by a fully trained mechanic.

All specifications are non-binding. KTM Sportmotorcycle GmbH specifically reserves the right to modify or delete technical specifications, prices, colors, forms, materials, services, designs, equipment, etc., without prior notice and without specifying reasons, to adapt these to local conditions, as well as to stop production of a particular model without prior notice. KTM accepts no liability for delivery options, deviations from figures and descriptions, misprints, and other errors. The models portrayed partly contain special equipment that does not belong to the regular scope of supply.

© 2017 KTM Sportmotorcycle GmbH, Mattighofen Austria

All rights reserved

Reproduction, even in part, as well as copying of all kinds, is permitted only with the express written permission of the copyright owner.



ISO 9001(12 100 6061)

According to the international quality management standard ISO 9001, KTM uses quality assurance processes that lead to the maximum possible quality of the products.

Issued by: TÜV Management Service

REG.NO. 12 100 6061

KTM Sportmotorcycle GmbH

Stallhofnerstraße 3

5230 Mattighofen, Austria

This document is valid for the following models:

125 XC-W EU (F7103R3)

150 XC-W US (F7175R3)



3213704en

04/2017

# 1 MEANS OF REPRESENTATION

## 1.1 Symbols used

The meaning of specific symbols is described below.



Indicates an expected reaction (e.g. of a work step or a function).



Indicates an unexpected reaction (e.g. of a work step or a function).



Indicates a page reference (more information is provided on the specified page).



Indicates information with more details or tips.



Indicates the result of a testing step.



Indicates a voltage measurement.



Indicates a current measurement.



Indicates a resistance measurement.



Indicates the end of an activity including potential rework.

## 1.2 Formats used

The typographical formats used in this document are explained below.

**Proprietary name**

Indicates a proprietary name.

**Name®**

Indicates a protected name.

**Brand™**

Indicates a brand available on the open market.

**Underlined terms**

Refer to technical details of the vehicle or indicate technical terms, which are explained in the glossary.

## 2.1 Unpacking and setting up the vehicle

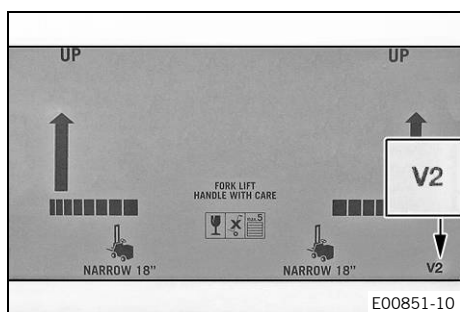

### Condition

#### Packaging V2

- Remove the box and the plastic packaging.



#### Info

An assistant prevents the motorcycle from falling over.  
To avoid damaging the motorcycle during the setup, leave the protective film on the vehicle until you have finished.

- Remove the separate enclosure and unpack it. Check that the scope of supply is complete using the enclosed packing list.
- Have a lift stand available.

Lift stand (78129955100)

- Carefully loosen and remove the tension belt of the footrest mount.



#### Info

An assistant prevents the motorcycle from falling over.

- Together with an assistant, take the vehicle off the pallet.
- Position the vehicle on a lift stand.
- Check the vehicle and attachments for transport damage.
- Remove the headlight mask with the headlight. (📖 p. 21)

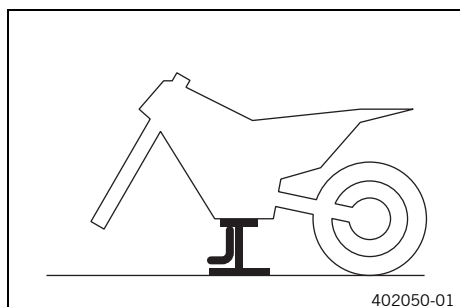

### Condition

#### Packaging V12

- Remove the box and the plastic packaging.



#### Info

An assistant prevents the motorcycle from falling over.  
To avoid damaging the motorcycle during the setup, leave the protective film on the vehicle until you have finished.

- Remove and unpack the separate enclosure and attachments. Check that the scope of supply is complete using the enclosed packing list.
- Have a lift stand available.

Lift stand (78129955100)

- Remove the two cable ties on the triple clamp.

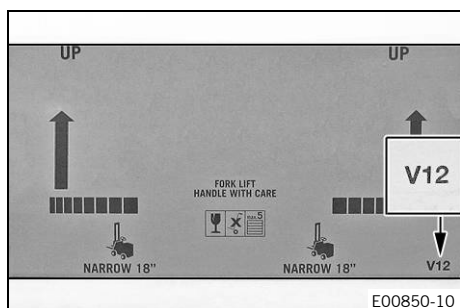

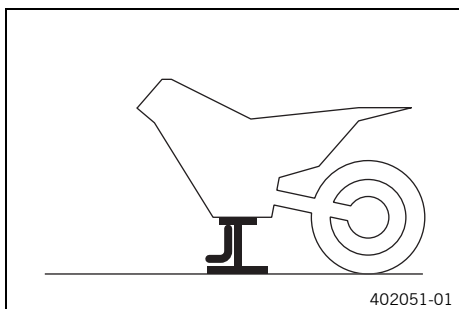

- Together with an assistant, take the vehicle off the pallet.
- Position the vehicle on a lift stand.
- Check the vehicle and attachments for transport damage.
- Install the shock absorber. (📖 p. 15)

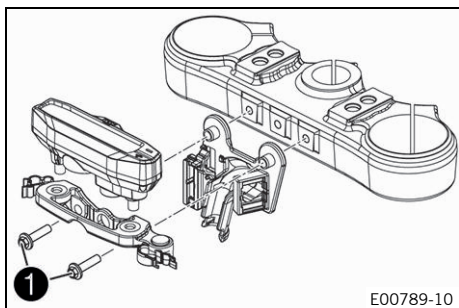

### (125 XC-W EU)

- Position the connector retainer and speedometer on the upper triple clamp.
- Mount and tighten screws **1**.

#### Guideline

Remaining screws, chassis	M6	10 Nm (7.4 lbf ft)
---------------------------	----	-----------------------

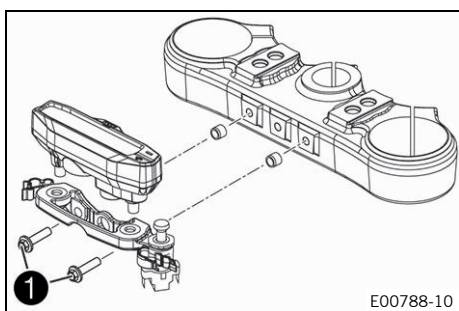

### (150 XC-W US)

- Position the speedometer on the upper triple clamp.
- Mount and tighten screws **1** with the collar bushings.

#### Guideline

Remaining screws, chassis	M6	10 Nm (7.4 lbf ft)
---------------------------	----	-----------------------

- Route the clutch line with the clutch master cylinder toward the front between the upper and lower triple clamps.
- Install the fork legs. (📖 p. 16)

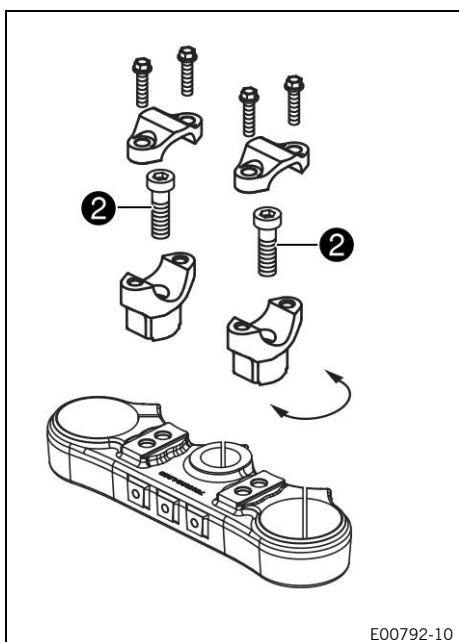

- Take off screws **2** and handlebar supports.
- Move the handlebar supports to the desired position and mount and tighten screws **2**.

#### Guideline

Screw, handlebar support	M10	40 Nm (29.5 lbf ft) <b>Loctite®243™</b>
--------------------------	-----	--



#### Info

Position the left and right handlebar supports evenly.

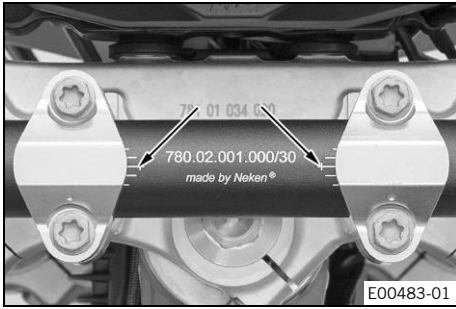

### Warning

**Danger of accidents** A repaired handlebar poses a safety risk.

If the handlebar is bent or straightened, the material becomes fatigued. The handlebar may break as a result.

- Change the handlebar if the handlebar is damaged or bent.

- Position the handlebar.



### Info

Make sure the cables and wiring are positioned correctly.

- Position the handlebar clamps. Mount and tighten the screws evenly.

Guideline

Screw, handlebar clamp	M8	20 Nm (14.8 lbf ft)
------------------------	----	---------------------



### Info

The markings on the handlebar should be at the center of the handlebar clamps.

Keep the gap widths equal when tightening.

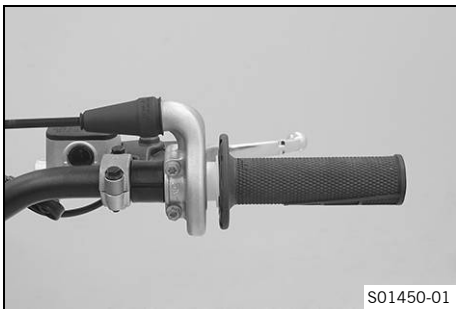

### (125 XC-W EU)

- Position the controls on the right half of the handlebar.



### (150 XC-W US)

- Position the controls on the right half of the handlebar.

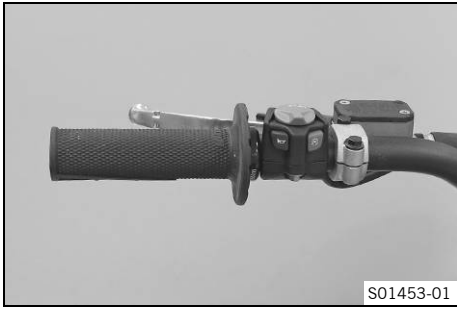

### (125 XC-W EU)

- Position the controls on the left half of the handlebar.

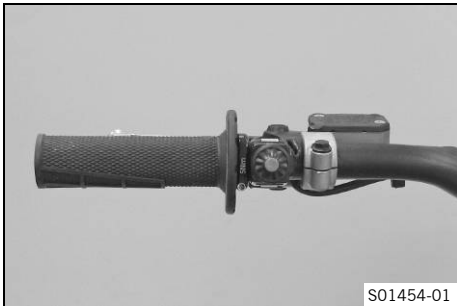

### (150 XC-W US)

- Position the controls on the left half of the handlebar.

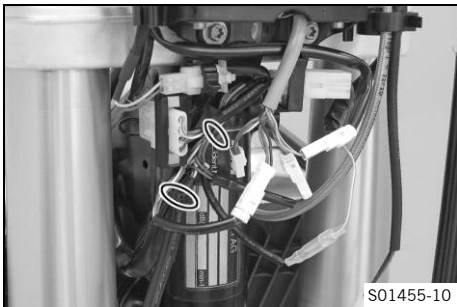

### Condition

Packaging **V12**

#### (125 XC-W EU)

- Connect all plug-in connectors to the plug-in holder.
- Route the cable without tension and secure with cable tie.

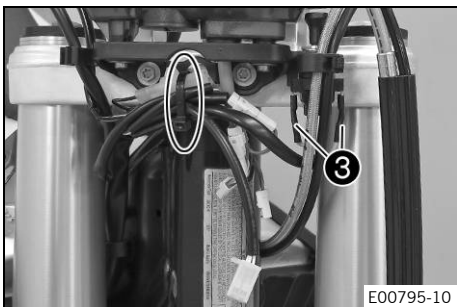

#### (150 XC-W US)

- Connect all plug-in connectors.
- Connect light pull switch **3** with the yellow and white cables.
- Route the cable without tension and secure with cable tie.



- Route the cable without tension and secure with cable ties and cable holder.





- Preassemble the hand guards on the left and right.

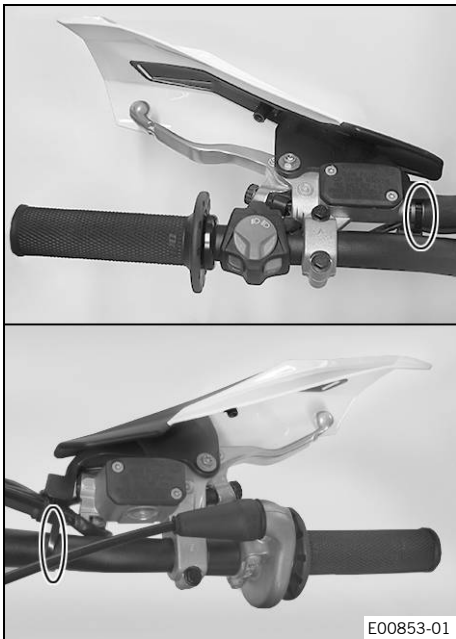

- Mount the left hand guard.
- Mount the right hand guard.

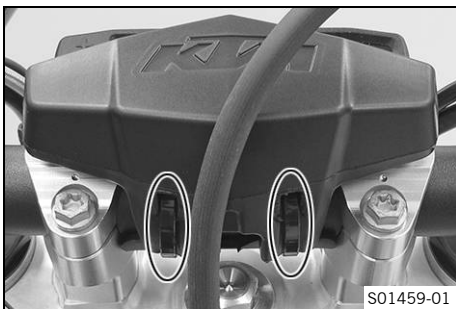

- Secure the handlebar cushion with two cable ties.
  - Install front fender. (📖 p. 20)
  - Install the front wheel. (📖 p. 16)
- (150 XC-W US)**
- Recharge the battery. (📖 p. 18)



- Position the right footrest and pin.

**Info**

Only insert the pin to the extent that the spring can still be mounted.

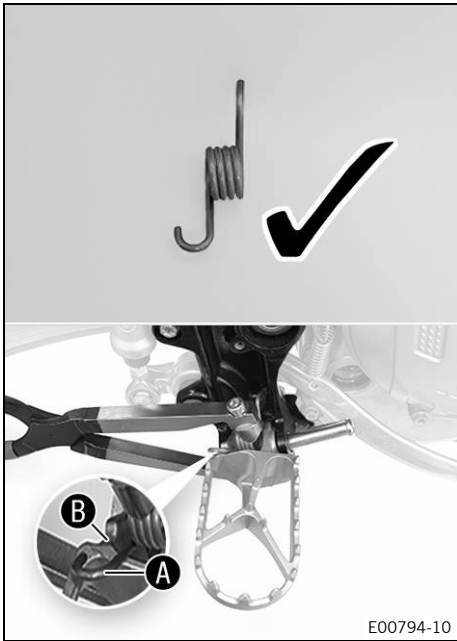

- Position spring as shown.
  - ✓ Spring **A** engages in area **B**.

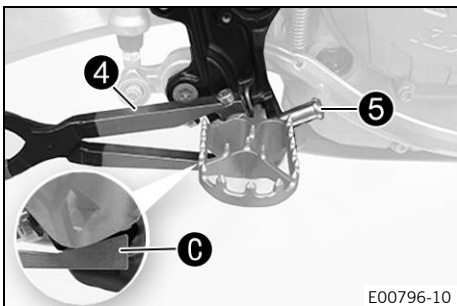

- Press the spring with special tool **4**.

Pliers for footrest spring (79029083000)

- ✓ The special tool is applied to area **C** on the footrest.
- Mount pin **5**.

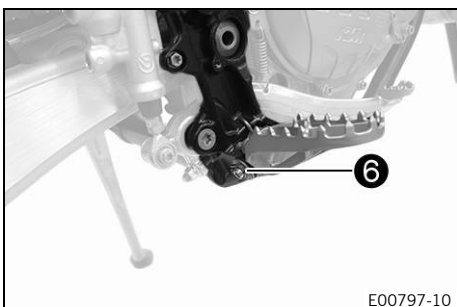

- Mount the washer and split pin **6**.

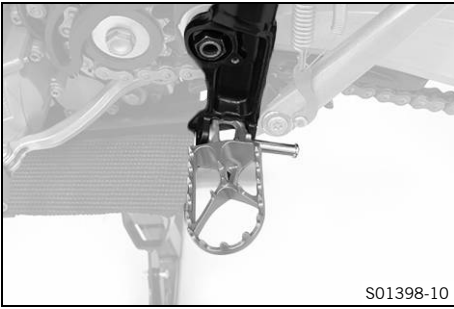

- Position the left footrest and pin.

---

**i Info**  
Only insert the pin to the extent that the spring can still be mounted.

---

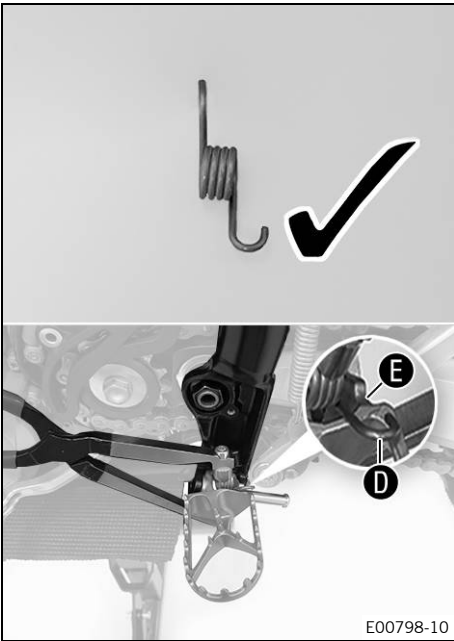

- Position spring as shown.
- ✓ Spring **D** engages in area **E**.

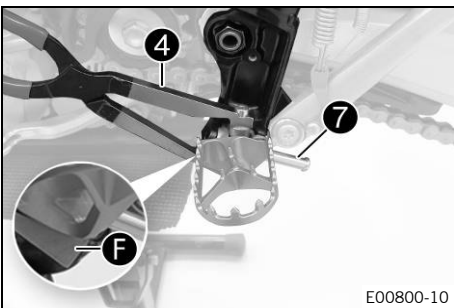

- Press the spring with special tool **4**.

Pliers for footrest spring (79029083000)
--

- ✓ The special tool is applied to area **F** on the footrest.
- Mount pin **7**.

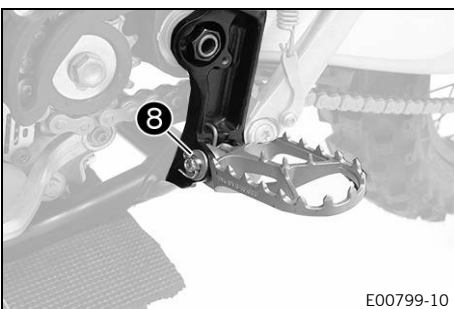

- Mount the washer and split pin **8**.

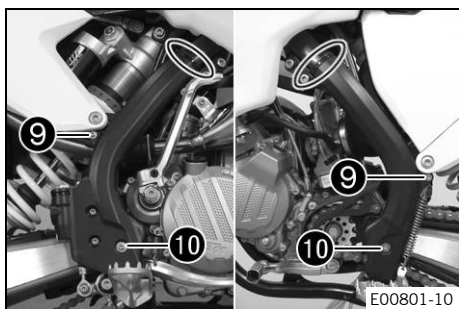

- Position the frame protectors on both sides.
- Mount and tighten screws 9.

Guideline

Screw, frame protector	M5	3 Nm (2.2 lbf ft)
------------------------	----	-------------------

- Mount and tighten screws 10 with the washers.

Guideline

Screw, frame protector	M5	3 Nm (2.2 lbf ft)
------------------------	----	-------------------

- Mount the cable tie(s).
- Unpack and mount the **KTM PowerParts** included in the delivery (optional).



### Info

Read the accompanying **KTM PowerParts** fitting instructions.

- Set kilometers or miles. (📖 p. 25)
- Adjust the combination instrument function. (📖 p. 26)
- Set the clock. (📖 p. 26)
- Refuel. (📖 p. 24)
- Position all controls in their exact positions on the handlebar. Tighten all screws.
- Prepare the vehicle according to the specifications in the **KTM Dealer.net** for handover to the customer.

### 3.1 Raising the motorcycle with a lift stand

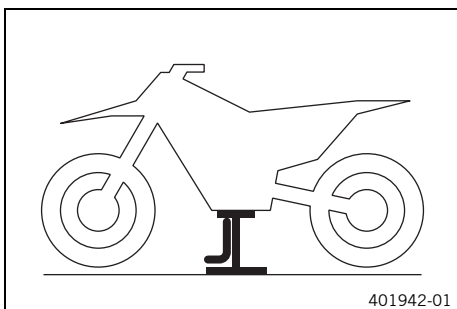

#### Note

**Danger of damage** The parked vehicle can roll away or fall over.

- Park the vehicle on a firm and level surface.
- Raise the motorcycle at the frame underneath the engine.

Lift stand (78129955100)

- ✓ Neither wheel is in contact with the ground.
- Secure the motorcycle against falling over.



### 3.2 Removing the motorcycle from the lift stand

#### Note

**Danger of damage** The parked vehicle can roll away or fall over.

- Park the vehicle on a firm and level surface.

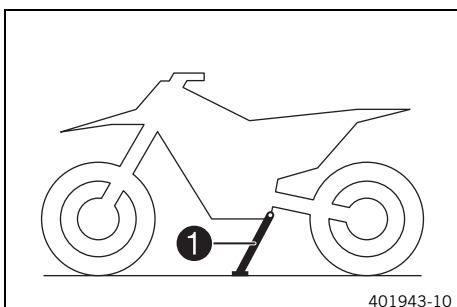

- Remove the motorcycle from the lift stand.
- Remove the lift stand.
- To park the motorcycle, press side stand ① to the ground with your foot and lean the motorcycle on it.



#### Info

When you are riding, the side stand must be folded up and secured with the rubber band.



### 3.3 Removing the seat

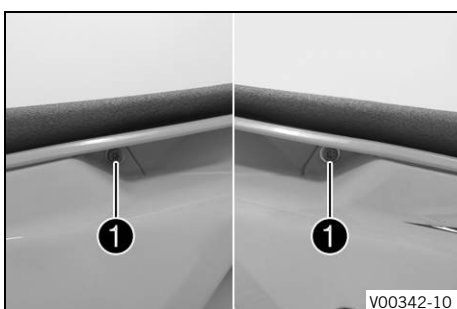

- Remove screws ①.
- Raise the rear of the seat, pull the seat back, and lift it off.



## 3.4 Mounting the seat

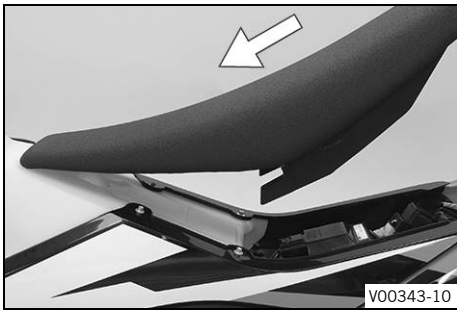

- Hook in the front of the seat on the collar bushing of the fuel tank, lower it at the rear and push it forward.
- Make sure that the seat is correctly locked in.

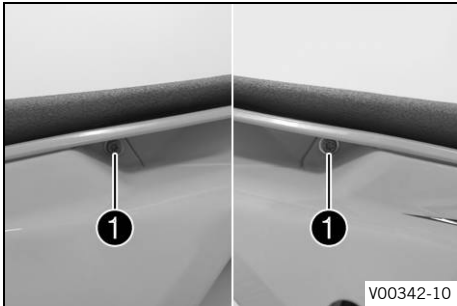

- Mount and tighten screws ①.

Guideline

Remaining screws, chassis	M6	10 Nm (7.4 lbf ft)
---------------------------	----	--------------------

## 3.5 Removing the fuel tank



### Danger

**Fire hazard** Fuel is highly flammable.

The fuel in the fuel tank expands when warm and can escape if overfilled.

- Do not refuel the vehicle in the vicinity of open flames or lit cigarettes.
- Switch off the engine for refueling.
- Make sure that no fuel is spilled; particularly not on hot parts of the vehicle.
- If any fuel is spilled, wipe it off immediately.
- Observe the specifications for refueling.



### Warning

**Danger of poisoning** Fuel is poisonous and a health hazard.

- Avoid skin, eye and clothing contact with fuel.
- Immediately consult a doctor if you swallow fuel.
- Do not inhale fuel vapors.
- In case of skin contact, rinse the affected area with plenty of water.
- Rinse the eyes thoroughly with water, and consult a doctor in case of fuel contact with the eyes.
- Change your clothing in case of fuel spills on them.
- Keep fuels correctly in a suitable canister, and out of the reach of children.

### Preparatory work

- Remove the seat. (📖 p. 11)

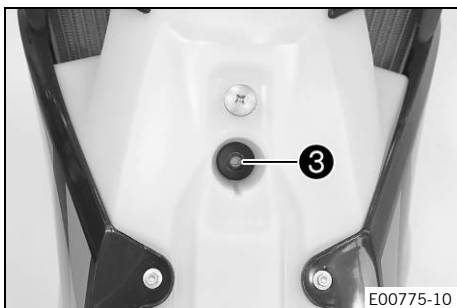
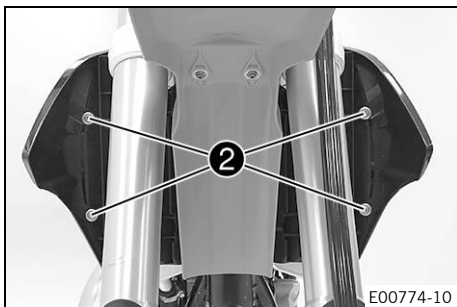
**Main work**

- Turn handle ① of the fuel tap to the **OFF** position. (Figure V00326-10  p. 25)
- Pull off the fuel hose.

**Info**

Remaining fuel may flow out of the fuel hose.

- Remove screws ② with the collar bushings.
- Remove screw ③ with the rubber bushing.
- Remove the tube from the fuel tank breather.
- Pull both spoilers off the sides of the radiator bracket and lift off the fuel tank.

### 3.6 Installing the fuel tank

**Danger**

**Fire hazard** Fuel is highly flammable.

The fuel in the fuel tank expands when warm and can escape if overfilled.

- Do not refuel the vehicle in the vicinity of open flames or lit cigarettes.
- Switch off the engine for refueling.
- Make sure that no fuel is spilled; particularly not on hot parts of the vehicle.
- If any fuel is spilled, wipe it off immediately.
- Observe the specifications for refueling.

**Warning**

**Danger of poisoning** Fuel is poisonous and a health hazard.

- Avoid skin, eye and clothing contact with fuel.
- Immediately consult a doctor if you swallow fuel.
- Do not inhale fuel vapors.
- In case of skin contact, rinse the affected area with plenty of water.
- Rinse the eyes thoroughly with water, and consult a doctor in case of fuel contact with the eyes.
- Change your clothing in case of fuel spills on them.

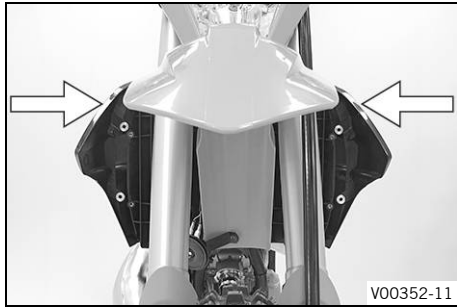

### Main work

- Check throttle cable routing. (📖 p. 14)
- Position the fuel tank and fit the two spoilers to the sides of the radiator bracket.
- Make sure that no cables or throttle cables are trapped or damaged.

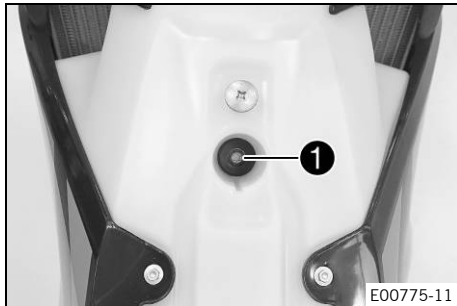

- Attach the fuel tank breather hose.
- Mount and tighten screw **1** with the rubber bushing.

#### Guideline

Remaining screws, chassis	M6	10 Nm (7.4 lbf ft)
---------------------------	----	--------------------

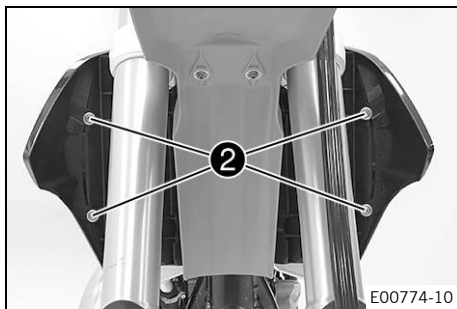

- Mount and tighten screws **2** with the collar bushings.

#### Guideline

Remaining screws, chassis	M6	10 Nm (7.4 lbf ft)
---------------------------	----	--------------------

- Connect the fuel hose.

### Finishing work

- Mount the seat. (📖 p. 12)

## 3.7 Checking throttle cable routing



### Warning

**Danger of accidents** The throttle cable may slip out of the guide if routed incorrectly. The throttle slide will then no longer be closed and the speed can no longer be controlled.

- Make sure that the throttle cable routing and the play in throttle cable complies with the specification.

### Preparatory work

- Remove the seat. (📖 p. 11)
- Remove the fuel tank. (📖 p. 12)

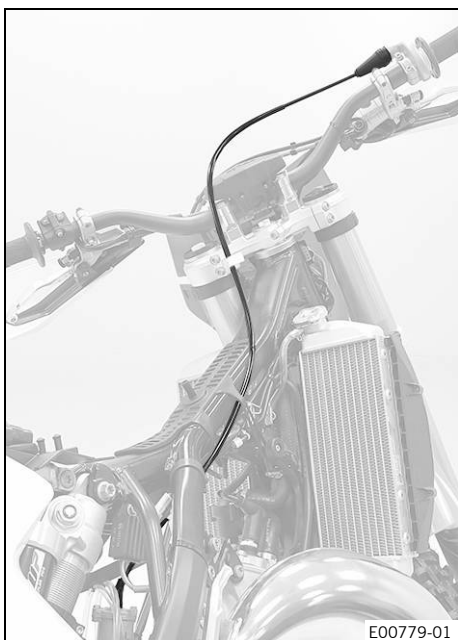

**Main work**

- Check throttle cable routing.

The throttle cable must be routed behind the handlebar, on the right of the frame, and to the carburetor. The throttle cable must be secured behind the fuel tank contact area rubber band.

- » If the throttle cable routing is not as specified:
  - Correct throttle cable routing.

**Finishing work**

- Install the fuel tank. (🔧 p. 13)
- Mount the seat. (🔧 p. 12)

### 3.8 Installing the shock absorber

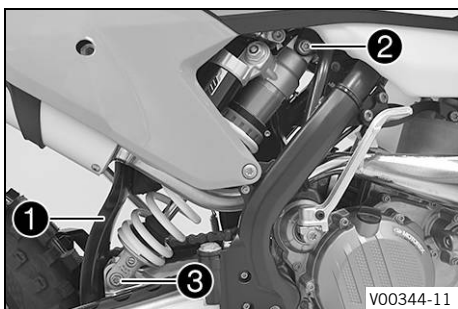
**Main work**

- Push splash protector ❶ to the side and position the shock absorber. Mount and tighten screw ❷.

## Guideline

Screw, top shock absorber	M12	80 Nm (59 lbf ft) <b>Loctite®2701™</b>
---------------------------	-----	---

- Mount and tighten screw ❸.

## Guideline

Screw, bottom shock absorber	M12	80 Nm (59 lbf ft) <b>Loctite®2701™</b>
------------------------------	-----	---

**Info**

The heim joint for the shock absorber at the swingarm is Teflon-coated. It must not be greased with grease or with other lubricants. Lubricants dissolve the Teflon coating, thereby drastically reducing the service life.

**Finishing work**

- Remove the motorcycle from the lift stand. (🔧 p. 11)

## 3.9 Installing the fork legs

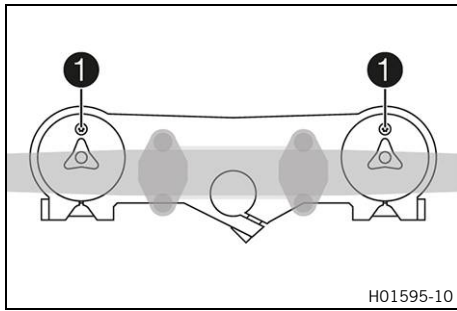

### Main work

- Position the fork legs.
- ✓ Bleeder screws **1** are positioned toward the front.

### Info

The rebound damping is located in right fork leg **REB** (red adjusting screw). The compression damping is located in left fork leg **COM** (white adjusting screw). Grooves are milled into the side of the upper end of the fork legs. The second milled groove (from the top) must be flush with the top edge of the upper triple clamp.

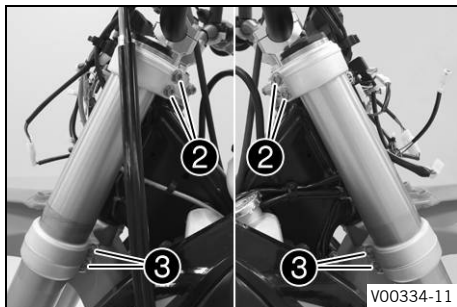

- Tighten screws **2**.

### Guideline

Screw, top triple clamp	M8	20 Nm (14.8 lbf ft)
-------------------------	----	---------------------

- Tighten screws **3**.

### Guideline

Screw, bottom triple clamp	M8	15 Nm (11.1 lbf ft)
----------------------------	----	---------------------

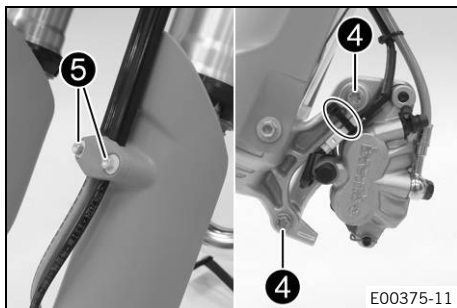

- Position the brake caliper, and mount and tighten screws **4**.

### Guideline

Screw, front brake caliper	M8	25 Nm (18.4 lbf ft) <b>Loctite®243™</b>
----------------------------	----	--

- Mount the cable tie(s).
- Position the brake line, wiring harness, and clamp. Mount and tighten screws **5**.

### Finishing work

- Install the front wheel. (📖 p. 16)
- Install the headlight mask with the headlight. (📖 p. 21)
- Check the headlight setting. (📖 p. 22)

## 3.10 Installing the front wheel



### Warning

**Danger of accidents** Oil or grease on the brake discs reduces the braking effect.

- Always keep the brake discs free of oil and grease.
- Clean the brake discs with brake cleaner when necessary.

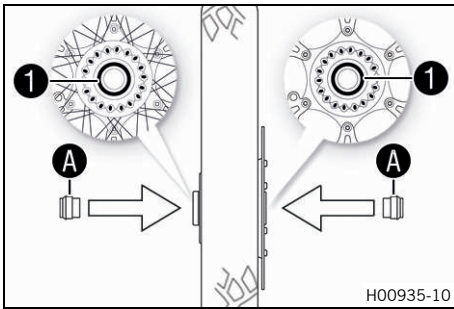

- Check the wheel bearing for damage and wear.
  - » If the wheel bearing is damaged or worn:
    - Change front wheel bearing.
- Clean and grease shaft seal rings **1** and contact surface **A** of the spacers.

Long-life grease (🗨️ p. 31)
-----------------------------

- Insert the spacers.
- Clean and grease the wheel spindle.

Long-life grease (🗨️ p. 31)
-----------------------------

- Lift the front wheel into the fork, position it, and insert the wheel spindle.

✓ The brake linings are correctly positioned.

- Mount and tighten screw **2**.

Guideline

Screw, front wheel spindle	M20x1.5	35 Nm (25.8 lbf ft)
----------------------------	---------	---------------------

- Operate the hand brake lever several times until the brake linings are seated correctly against the brake disc.
- Remove the motorcycle from the lift stand. (🗨️ p. 11)
- Operate the front brake and compress the fork a few times firmly.

✓ The fork legs straighten.

- Tighten screws **3**.

Guideline

Screw, fork stub	M8	15 Nm (11.1 lbf ft)
------------------	----	---------------------

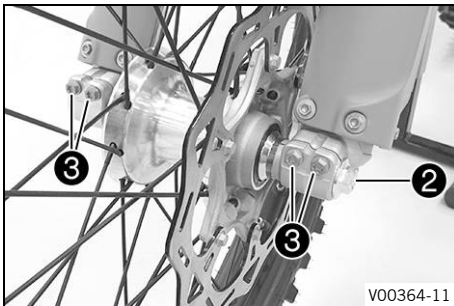

## 3.11 Removing the battery (150 XC-W US)



### Warning

**Environmental hazard** Batteries contain environmentally-hazardous materials.

- Do not dispose of batteries as household waste.
- Dispose of batteries at a collection point for used batteries.



### Warning

**Environmental hazard** Hazardous substances cause environmental damage.

- Dispose of oils, grease, filters, fuel, cleaning agents, brake fluid, etc., correctly and in compliance with the applicable regulations.

### Preparatory work

- Press and hold the kill switch ☒ while the engine is idling until the engine stops.
- Remove the seat. (🗨️ p. 11)

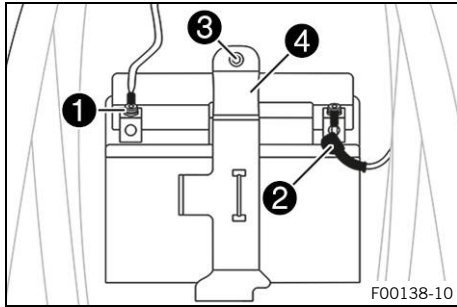

## Main work



### Warning

**Risk of injury** Batteries contain harmful substances.

- Keep batteries out of the reach of children.
- Keep sparks and open flames away from the batteries.
- Only charge batteries in well-ventilated rooms.
- Maintain a minimum clearance from inflammable materials when charging batteries.  
Minimum clearance 1 m (3 ft)
- Do not charge deeply discharged batteries if charge is already below the minimum voltage.  
Minimum voltage before 9 V the start of the charge
- Dispose of batteries with less than the minimum voltage correctly.

- Disconnect negative cable ① from the battery.
- Pull back positive terminal cover ② and disconnect the positive cable from the battery.
- Remove screw ③.
- Pull holding bracket ④ forward and remove battery toward the top.

## 3.12 Recharging the battery (150 XC-W US)



### Warning

**Risk of injury** Batteries contain harmful substances.

- Keep batteries out of the reach of children.
- Keep sparks and open flames away from the batteries.
- Only charge batteries in well-ventilated rooms.
- Maintain a minimum clearance from inflammable materials when charging batteries.  
Minimum clearance 1 m (3 ft)
- Do not charge deeply discharged batteries if charge is already below the minimum voltage.  
Minimum voltage before the start of the charge 9 V
- Dispose of batteries with less than the minimum voltage correctly.



### Warning

**Environmental hazard** Batteries contain environmentally-hazardous materials.

- Do not dispose of batteries as household waste.
- Dispose of batteries at a collection point for used batteries.



### Warning

**Environmental hazard** Hazardous substances cause environmental damage.

- Dispose of oils, grease, filters, fuel, cleaning agents, brake fluid, etc., correctly and in compliance with the applicable regulations.

**i Info**

Even when there is no load on the battery, it discharges steadily.

The charging level and the method of charging are very important for the service life of the battery.

Rapid recharging with a high charging current shortens the service life of the battery.

If the charging current, charging voltage, or charging time are exceeded, the battery will be destroyed.

If the battery is depleted by repeated starting, the battery must be charged immediately.

If the battery is left in a discharged state for an extended period, it will become over-discharged and sulfated, destroying the battery.

The battery is maintenance-free.

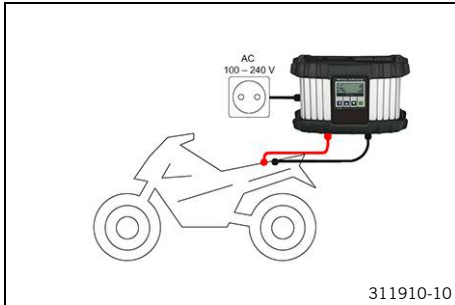
**Preparatory work**

- Remove the seat. (📖 p. 11)

**Main work**

- Connect the battery charger to the battery. Set the battery charger.

**Alternative 1**

Battery charger **XCharge-professional** EU  
(00029095050)

**Alternative 2**

Battery charger **XCharge-professional** US  
(00029095051)

**Alternative 3**

Battery charger **XCharge-professional** GB  
(00029095052)

**Alternative 4**

Battery charger **XCharge-professional** CH  
(00029095053)

**Info**

Follow the instructions of the charger and the manual.

- Disconnect the battery charger after charging the battery.

**Guideline**

The charging current, charging voltage, and charging time must not be exceeded.

Charge the battery regularly when the motorcycle is not in use	3 months
--	----------

**Finishing work**

- Mount the seat. (📖 p. 12)

## 3.13 Installing the battery (150 XC-W US)

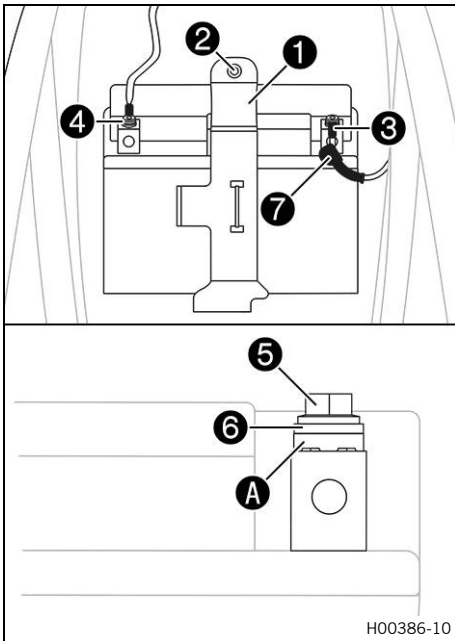

### Main work

- Insert the battery into the battery compartment with the terminals facing forward and secure with holding bracket **1**.

Battery (HJTZ5S-FP)

- Mount and tighten screw **2**.

### Guideline

Remaining screws, chassis	M6	10 Nm (7.4 lbf ft)
---------------------------	----	--------------------

- Connect positive cable **3** to the battery.

### Guideline

Screw, battery terminal	M5	2.5 Nm (1.84 lbf ft)
-------------------------	----	----------------------

- Slide positive terminal cover **7** over the positive terminal.

- Connect negative cable **4** to the battery.

### Guideline

Screw, battery terminal	M5	2.5 Nm (1.84 lbf ft)
-------------------------	----	----------------------

Contact disks **A** must be mounted under screws **5** and cable sockets **6** with the claws toward the battery terminal.

### Finishing work

- Mount the seat. (📖 p. 12)

## 3.14 Installing front fender

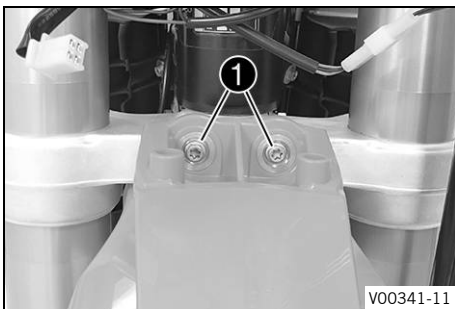

### Main work

- Position front fender. Mount and tighten screws **1**.

### Guideline

Remaining screws, chassis	M6	10 Nm (7.4 lbf ft)
---------------------------	----	--------------------

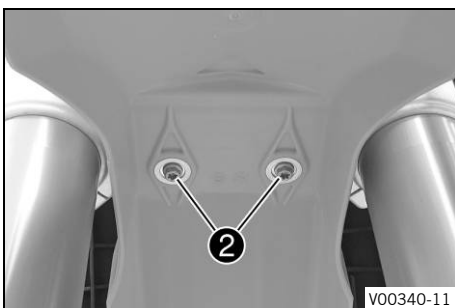

- Mount and tighten screws **2**.

### Guideline

Remaining screws, chassis	M6	10 Nm (7.4 lbf ft)
---------------------------	----	--------------------

**Finishing work**

- Install the headlight mask with the headlight. (🔧 p. 21)
- Check the headlight setting. (🔧 p. 22)

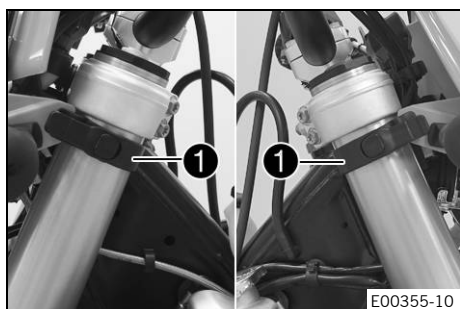
**3.15 Removing the headlight mask with the headlight**

E00355-10

**(125 XC-W EU)**

- Press and hold the kill switch ☒ while the engine is idling until the engine stops.

**(150 XC-W US)**

- Press and hold the kill switch ☒ while the engine is idling until the engine stops.
- Detach the brake line and wiring harness from the headlight mask.
- Release rubber bands ①. Slide the headlight mask up and swing it forward.
- Detach plug-in connector ② and take off the headlight mask with the headlight.

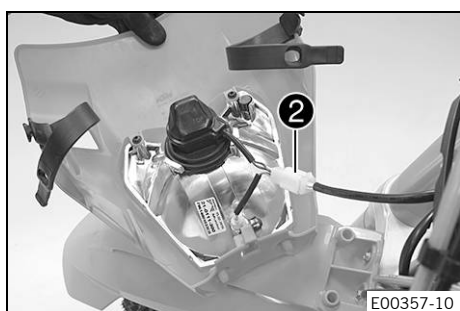

E00357-10

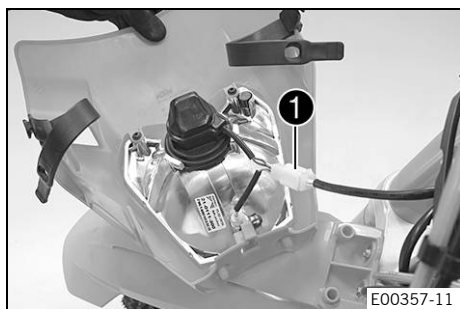
**3.16 Installing the headlight mask with the headlight**

E00357-11

**Main work**

- Connect plug-in connector ①.

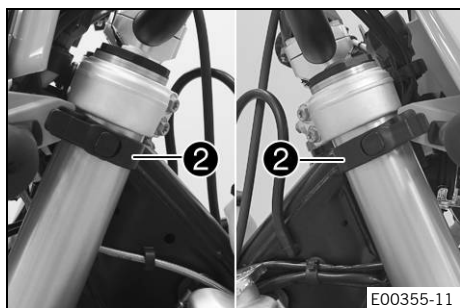

E00355-11

- Position the headlight mask and fix it with rubber bands ②.
  - ✓ The holding lugs engage in the fender.
- Position the brake line and wiring harness in the brake line guide.

**Finishing work**

- Check the headlight setting. (🔧 p. 22)

## 3.17 Checking the headlight setting

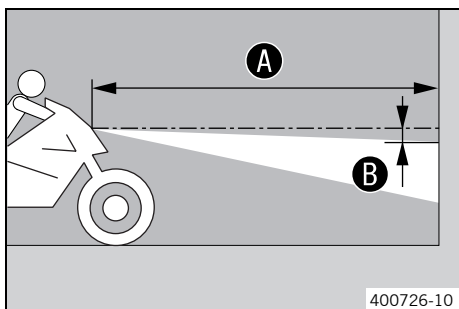

- Position the vehicle upright on a horizontal surface in front of a light wall and make a mark at the height of the center of the low beam headlight.

- Make another mark at a distance **B** under the first mark.  
Guideline

Distance <b>B</b>	5 cm (2 in)
-------------------	-------------

- Position the vehicle vertically a distance **A** away from the wall.  
Guideline

Distance <b>A</b>	5 m (16 ft)
-------------------	-------------

- The rider now sits down on the motorcycle.
- Switch on the low beam.
- Check the headlight setting.

The boundary between light and dark must be exactly on the lower mark for a motorcycle with rider.
--

- » If the light-dark border does not meet specifications:
  - Adjust the headlight range. (📖 p. 22)

## 3.18 Adjusting the headlight range

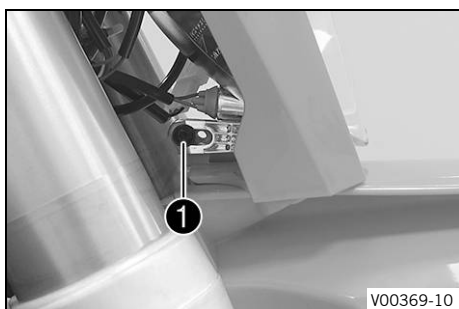

### Preparatory work

- Check the headlight setting. (📖 p. 22)

### Main work

- Loosen screw **1**.
- Adjust the headlight range by pivoting the headlight.

### Guideline

The boundary between light and dark must be exactly on the lower marking for a motorcycle with rider (instructions on how to apply the marking: Checking the headlight setting).
--

### Info

If you have a payload, you may have to correct the headlight range.

- Tighten screw **1**.



### 3.19 Opening the filler cap



#### Danger

**Fire hazard** Fuel is highly flammable.

The fuel in the fuel tank expands when warm and can escape if overfilled.

- Do not refuel the vehicle in the vicinity of open flames or lit cigarettes.
- Switch off the engine for refueling.
- Make sure that no fuel is spilled; particularly not on hot parts of the vehicle.
- If any fuel is spilled, wipe it off immediately.
- Observe the specifications for refueling.



#### Warning

**Danger of poisoning** Fuel is poisonous and a health hazard.

- Avoid skin, eye and clothing contact with fuel.
- Immediately consult a doctor if you swallow fuel.
- Do not inhale fuel vapors.
- In case of skin contact, rinse the affected area with plenty of water.
- Rinse the eyes thoroughly with water, and consult a doctor in case of fuel contact with the eyes.
- Change your clothing in case of fuel spills on them.
- Keep fuels correctly in a suitable canister, and out of the reach of children.



#### Warning

**Environmental hazard** Improper handling of fuel is a danger to the environment.

- Do not allow fuel to enter the groundwater, the soil, or the sewage system.



- Press release button ①, turn the filler cap counterclockwise and lift it free.

### 3.20 Closing the filler cap

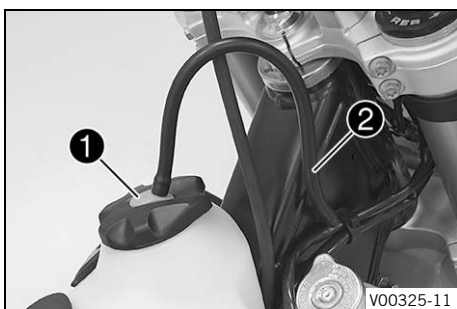

- Replace the filler cap and turn clockwise until the release button ① locks in place.



#### Info

Run the fuel tank breather hose ② without kinks.

## 3.21 Refueling



### Danger

**Fire hazard** Fuel is highly flammable.

The fuel in the fuel tank expands when warm and can escape if overfilled.

- Do not refuel the vehicle in the vicinity of open flames or lit cigarettes.
- Switch off the engine for refueling.
- Make sure that no fuel is spilled; particularly not on hot parts of the vehicle.
- If any fuel is spilled, wipe it off immediately.
- Observe the specifications for refueling.



### Warning

**Danger of poisoning** Fuel is poisonous and a health hazard.

- Avoid skin, eye and clothing contact with fuel.
- Immediately consult a doctor if you swallow fuel.
- Do not inhale fuel vapors.
- In case of skin contact, rinse the affected area with plenty of water.
- Rinse the eyes thoroughly with water, and consult a doctor in case of fuel contact with the eyes.
- Change your clothing in case of fuel spills on them.



### Warning

**Environmental hazard** Improper handling of fuel is a danger to the environment.

- Do not allow fuel to enter the groundwater, the soil, or the sewage system.

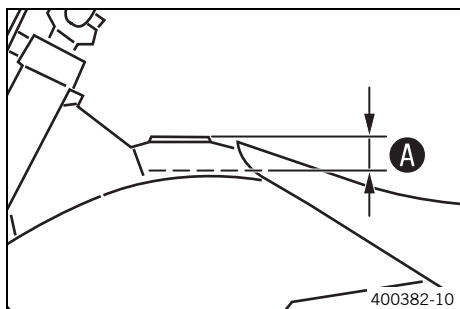

- Switch off the engine.
- Open the filler cap. (📖 p. 23)
- Fill the fuel tank with fuel up to measurement **A**.

Guideline

Measurement of <b>A</b>	35 mm (1.38 in)
-------------------------	-----------------

Total fuel tank capacity, approx.	9.5 l (2.51 US gal)	Super unleaded (95 octane) mixed with 2-stroke engine oil (1:60) (📖 p. 30)
-----------------------------------	------------------------	--

Engine oil, 2-stroke (📖 p. 30)
--------------------------------

- Close the filler cap. (📖 p. 23)

### 3.22 Fuel tap

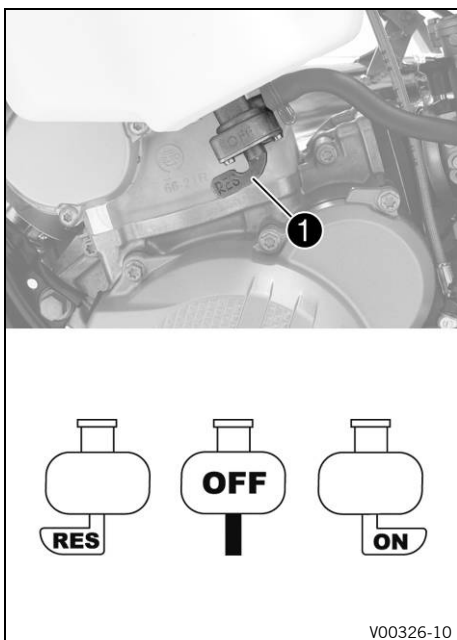

The fuel tap is on the left side of the fuel tank. Open or close the supply of fuel to the carburetor using tap handle **1** on the fuel tap.

#### Possible states

- Fuel supply closed **OFF** – Fuel cannot flow from the fuel tank to the carburetor.
- Fuel supply open **ON** – Fuel can flow from the fuel tank to the carburetor. The fuel tank empties down to the reserve level.
- Fuel reserve supply open **RES** – Fuel can flow from the fuel tank to the carburetor. The fuel tank empties completely.

### 3.23 Setting the kilometers or miles



#### Info

If you change the unit, the value **ODO** is retained and converted accordingly. The values **TR1**, **TR2**, **A1**, **A2** and **S1** are cleared when the unit of measure is changed.

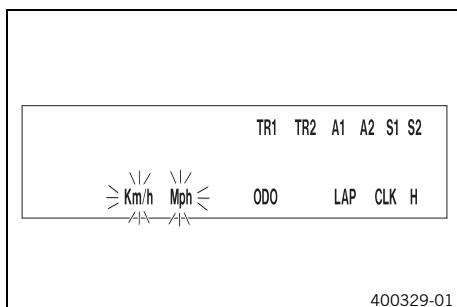

#### Condition

The motorcycle is stationary.

- Repeatedly press the button **+** briefly until **H** appears at the bottom right of the display.
- Press the button **+** for 2–3 seconds.
  - ✓ The Setup menu is displayed and the active functions are shown.
- Repeatedly press the button **+** briefly until **Km/h/Mph** flashes.

#### Setting the Km/h

- Press the button **+**.

#### Setting the Mph

- Press the button **-**.
- Wait 3 - 5 seconds.
  - ✓ The settings are stored.



#### Info

If no button is pressed for 10 -12 seconds, or if an impulse comes from the wheel speed sensor, the settings are automatically saved and the setup menu is closed.

### 3.24 Adjusting the combination instrument function

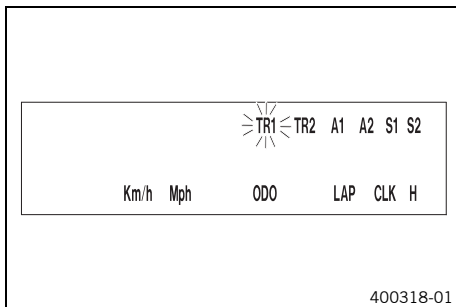

#### **i** Info

When the vehicle is delivered, only the **SPEED/H** and **SPEED/ODO** display modes are activated.



#### **Condition**

The motorcycle is stationary.

- Repeatedly press the button  briefly until **H** appears at the bottom right of the display.
- Press the button  for 2–3 seconds.
  - ✓ The Setup menu is displayed and the active functions are shown.

#### **i** Info

If no button is pressed for 10–12 seconds, the settings are automatically saved.  
If no button is pressed for 20 seconds, or if an impulse comes from the wheel speed sensor, the settings are automatically saved and the setup menu is closed.

- Repeatedly press the button  briefly until the desired function flashes.
  - ✓ The selected function flashes.

#### **Activating the function**

- Press the button .
  - ✓ The symbol continues to appear in the display and the next function appears.

#### **Deactivating a function**





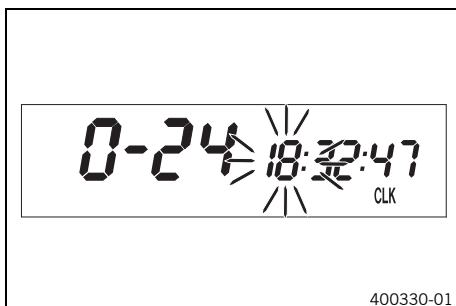

- Press the button .
  - ✓ The symbol disappears in the display and the next function appears.

### 3.25 Setting the clock



#### **Condition**

The motorcycle is stationary.

- Repeatedly press the button  briefly until **CLK** appears at the bottom right of the display.
- Press the button  for 2–3 seconds.
  - ✓ The hour display flashes.
- Set the hour display with the button  and/or button .
- Wait 3 - 5 seconds.
  - ✓ The next segment of the display flashes and can be set.
- You can set the following segments in the same way as the hours by pressing the button  and the button .

**Info**

The seconds can only be set to zero. If no button is pressed for 15 - 20 seconds, or if an impulse comes from the wheel speed sensor, the settings are automatically saved and the setup menu is closed.

---



## 4 TECHNICAL DATA

### 4.1 Chassis tightening torques

Remaining screws, chassis	<b>EJOT PT®</b> K60x25-Z	2 Nm (1.5 lbf ft)
Screw, seat fixing	<b>EJOT EJOFORM PT®</b> K60x23/18	2.5 Nm (1.84 lbf ft)
Screw, fixed grip	M4	5 Nm (3.7 lbf ft) <b>Loctite®243™</b>
Spoke nipple, front wheel	M4.5	6 Nm (4.4 lbf ft)
Spoke nipple, rear wheel	M4.5	6 Nm (4.4 lbf ft)
Remaining nuts, chassis	M5	5 Nm (3.7 lbf ft)
Remaining screws, chassis	M5	5 Nm (3.7 lbf ft)
Screw, battery terminal (150 XC-W US)	M5	2.5 Nm (1.84 lbf ft)
Screw, light switch (125 XC-W EU)	M5	1 Nm (0.7 lbf ft)
Screw, shock absorber adjusting ring	M5	5 Nm (3.7 lbf ft)
Nut, cable on starter motor (150 XC-W US)	M6	4 Nm (3 lbf ft)
Remaining nuts, chassis	M6	10 Nm (7.4 lbf ft)
Remaining screws, chassis	M6	10 Nm (7.4 lbf ft)
Screw, ball joint of push rod on foot brake cylinder	M6	10 Nm (7.4 lbf ft) <b>Loctite®243™</b>
Screw, chain sliding guard	M6	14 Nm (10.3 lbf ft) <b>Loctite®243™</b>
Screw, front brake disc	M6	14 Nm (10.3 lbf ft) <b>Loctite®243™</b>
Screw, manifold on silent block	M6	6 Nm (4.4 lbf ft)
Screw, rear brake disc	M6	14 Nm (10.3 lbf ft) <b>Loctite®243™</b>
Screw, silent block on frame	M6	6 Nm (4.4 lbf ft)
Screw, throttle grip	M6	5 Nm (3.7 lbf ft)
Nut, foot brake lever	M8	15 Nm (11.1 lbf ft)
Nut, foot brake lever stop	M8	20 Nm (14.8 lbf ft)
Nut, pull switch	M8	0.4 Nm (0.3 lbf ft)
Nut, rear sprocket screw	M8	35 Nm (25.8 lbf ft) <b>Loctite®2701™</b>
Nut, rim lock	M8	12 Nm (8.9 lbf ft)
Remaining nuts, chassis	M8	25 Nm (18.4 lbf ft)
Remaining screws, chassis	M8	25 Nm (18.4 lbf ft)
Screw, bottom triple clamp	M8	15 Nm (11.1 lbf ft)
Screw, chain sliding piece	M8	15 Nm (11.1 lbf ft)
Screw, engine brace	M8	25 Nm (18.4 lbf ft) <b>Loctite®2701™</b>
Screw, fork stub	M8	15 Nm (11.1 lbf ft)
Screw, front brake caliper	M8	25 Nm (18.4 lbf ft) <b>Loctite®243™</b>
Screw, handlebar clamp	M8	20 Nm (14.8 lbf ft)

Screw, side stand attachment	M8	35 Nm (25.8 lbf ft) <b>Loctite®2701™</b>
Screw, subframe	M8	35 Nm (25.8 lbf ft) <b>Loctite®2701™</b>
Screw, top steering stem	M8	20 Nm (14.8 lbf ft)
Screw, top triple clamp	M8	20 Nm (14.8 lbf ft)
Engine bracket screw	M10	60 Nm (44.3 lbf ft)
Remaining nuts, chassis	M10	45 Nm (33.2 lbf ft)
Remaining screws, chassis	M10	45 Nm (33.2 lbf ft)
Screw, handlebar support	M10	40 Nm (29.5 lbf ft) <b>Loctite®243™</b>
Screw, bottom shock absorber	M12	80 Nm (59 lbf ft) <b>Loctite®2701™</b>
Screw, top shock absorber	M12	80 Nm (59 lbf ft) <b>Loctite®2701™</b>
Nut, swingarm pivot	M16x1.5	100 Nm (73.8 lbf ft)
Nut, rear wheel spindle	M20x1.5	80 Nm (59 lbf ft)
Screw, front wheel spindle	M20x1.5	35 Nm (25.8 lbf ft)
Screw, top steering head	M20x1.5	12 Nm (8.9 lbf ft)
Screw-in nozzles, cooling system	M20x1.5	12 Nm (8.9 lbf ft) <b>Loctite®243™</b>

## Engine oil, 2-stroke

### Standard/classification

- JASO FD (📖 p. 32)

### Guideline

- Only use high grade 2-stroke engine oil of a reputable brand.

Fully synthetic
-----------------

### Recommended supplier

Motorex®

- Cross Power 2T

## Super unleaded (ROZ 95/RON 95/PON 91)

### Standard/classification

- DIN EN 228 (ROZ 95/RON 95/PON 91)

### Guideline

- Only use unleaded super fuel that matches or is equivalent to the specified fuel grade.
- Fuel with an ethanol content of up to 10 % (E10 fuel) is safe to use.



### Info

Do **not** use fuel containing methanol (e. g. M15, M85, M100) or more than 10 % ethanol (e. g. E15, E25, E85, E100).

## Super unleaded (95 octane) mixed with 2-stroke engine oil (1:60)

### Standard/classification

- DIN EN 228
- JASO FD (📖 p. 32) (1:60)

### Mixture ratio

1:60	Engine oil, 2-stroke (📖 p. 30) Super unleaded (ROZ 95/RON 95/PON 91) (📖 p. 30)
------	---

### Recommended supplier

Motorex®

- Cross Power 2T



### Long-life grease

Recommended supplier

Motorex®

– Bike Grease 2000

### JASO FD

JASO FD is a classification for a 2-stroke engine oil that was specifically developed for the extreme demands of racing. Thanks to first rate synthetic esters and specially designed additives, superb combustion is achieved even under extreme operating conditions.

**READY TO RACE**

>> [www.ktm.com](http://www.ktm.com)



3213704en

04/2017



**KTM**

**KTM Sportmotorcycle GmbH**  
5230 Mattighofen/Austria  
<http://www.ktm.com>



KTM Group Partner



REG. NO. 12 100 6661

Photo: Mitterbauer/KTM