

1290 Super Adventure S

Art. no. 3213785en



KTM

Perform the work described in these setup instructions before the vehicle is delivered to the customer.

Read the setup instructions in their entirety before beginning work.

These setup instructions were written to correspond to the latest state of this series. We reserve the right to make changes in the interest of technical advancement without at the same time updating this manual. We shall not provide a description of general workshop methods. Likewise, safety rules that apply in a workshop are not specified here. It is assumed that the work will be performed by a fully trained mechanic.

All specifications are non-binding. KTM Sportmotorcycle GmbH specifically reserves the right to modify or delete technical specifications, prices, colors, forms, materials, services, designs, equipment, etc., without prior notice and without specifying reasons, to adapt these to local conditions, as well as to stop production of a particular model without prior notice. KTM accepts no liability for delivery options, deviations from illustrations and descriptions, misprints, and other errors. The models portrayed partly contain special equipment that does not belong to the regular scope of supply.

© 2017 KTM Sportmotorcycle GmbH, Mattighofen Austria

All rights reserved

Reproduction, even in part, as well as copying of all kinds, is permitted only with the express written permission of the copyright owner.



ISO 9001(12 100 6061)

According to the international quality management standard ISO 9001, KTM uses quality assurance processes that lead to the maximum possible quality of the products.

Issued by: TÜV Management Service

REG.NO. 12 100 6061

KTM Sportmotorcycle GmbH

Stallhofnerstraße 3

5230 Mattighofen, Austria

This document is valid for the following models:

1290 Super Adventure S EU (F9903R4, F9903R5)

1290 Super Adventure S JP (F9986R4)

1290 Super Adventure S US (F9975R4, F9975R5)

1290 Super Adventure S CN (F9987R4)



1 MEANS OF REPRESENTATION

1.1 Symbols used

The meaning of specific symbols is described below.



Indicates an expected reaction (e.g. of a work step or a function).



Indicates an unexpected reaction (e.g. of a work step or a function).



Indicates a page reference (more information is provided on the specified page).



Indicates information with more details or tips.



Indicates the result of a testing step.



Indicates a voltage measurement.



Indicates a current measurement.



Indicates a resistance measurement.



Indicates the end of an activity including potential rework.

1.2 Formats used

The typographical formats used in this document are explained below.

Proprietary name

Indicates a proprietary name.

Name®

Indicates a protected name.

Brand™

Indicates a brand available on the open market.

Underlined terms

Refer to technical details of the vehicle or indicate technical terms, which are explained in the glossary.

2.1 Unpacking and setting up the vehicle

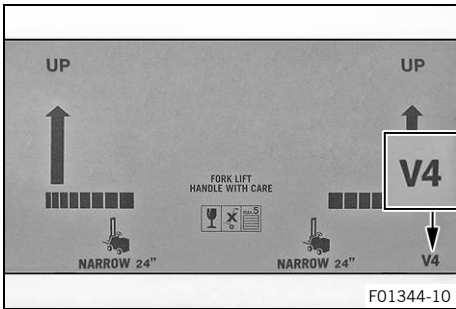

- Remove the straps and box.



- Remove the adhesive tape in the upper area of the motorcycle.



- Roll down the film at the sides.



Info

To avoid damaging the motorcycle during unpacking, leave the other films on the vehicle until you have finished work on the vehicle.

- Remove the separate enclosure and unpack it. Check the separate enclosure for completeness.
- Check the vehicle for transport damage.
- Remove the controls from the transport holder.
- Remove the screws and handlebar clamps.
- Remove the transport holder.

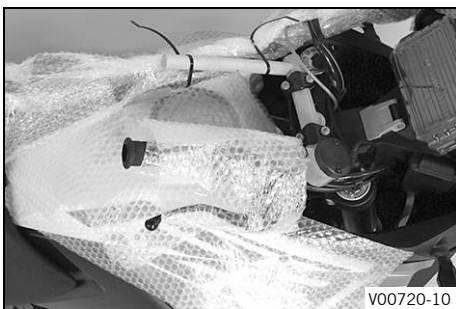

- Remove the right hand guard.
- Position the controls on the right half of the handlebar. Tighten the screws.

Guideline

Remaining screws, chassis	M5	5 Nm (3.7 lbf ft)
Remaining chassis screws	M6	10 Nm (7.4 lbf ft)



- Mount the right hand guard.

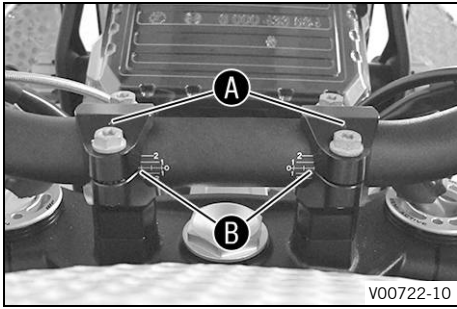

Warning

Danger of accidents A repaired handlebar poses a safety risk.

If the handlebar is bent or straightened, the material becomes fatigued. The handlebar may break as a result.

- Change the handlebar if the handlebar is damaged or bent.

- Position the handlebar.



Info

Make sure the cables and wiring are positioned correctly.

- Position the handlebar clamps. Tighten the screws evenly.

Guideline

Screw, handlebar clamp	M8	20 Nm (14.8 lbf ft)
------------------------	----	---------------------

- ✓ Markings **A** face backwards.
- ✓ Handlebar scale markings **B** are located centrally between the handlebar clamps.

- Check the throttle grip for smooth operation.
- Mount and tighten the rear mirror on both sides.

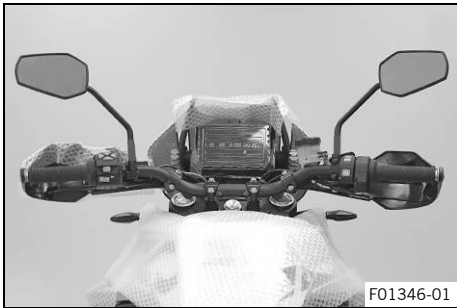

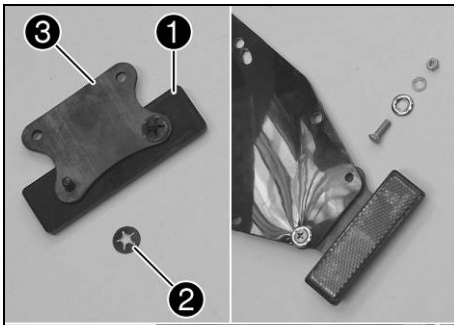

- Mount reflector ① with spring washers ② on holding plate ③.
- Mount the holding plate on the license plate bracket.

(EU/JP/CN)

- Mount the license plate holder.

(US)

- Bond the reflectors on the right and left side of the reflector holder.
- Mount the reflector holder on license plate bracket.
- Carefully loosen and remove the tension belt over the swingarm.

Guideline

An assistant prevents the motorcycle from falling over.

- Carefully loosen and remove the tension belts around the lower triple clamp.
 - ✓ The vehicle is released at the front.
- Together with an assistant, take the vehicle off the palette.



V00724-10

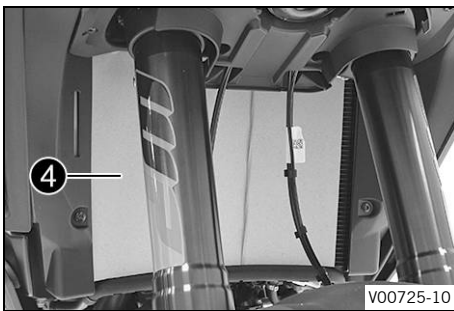

V00725-10

- Remove radiator shield ④.

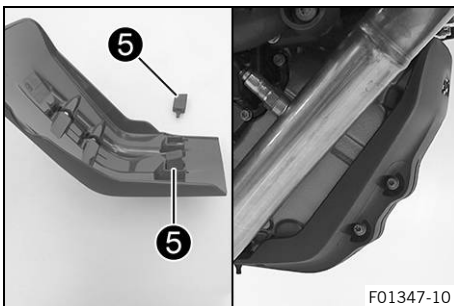

F01347-10

- Mount rubber dampers ⑤ on the engine guard.
- Position engine guard. Mount and tighten the screws with the distance sleeves.

Guideline

Screw, engine guard	M6	10 Nm (7.4 lbf ft)
---------------------	----	--------------------

Condition

Function **KTM MY RIDE** (optional) activated.

- Remove screws ⑥.
- Take off the headlight mask.

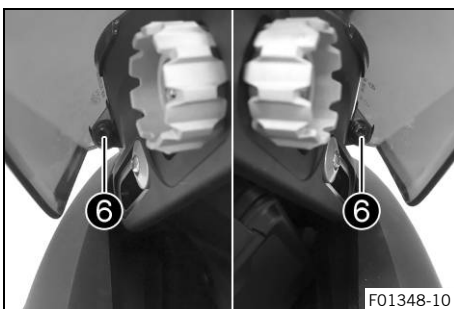

F01348-10

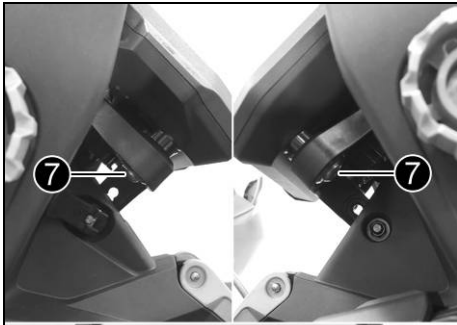

F01349-10

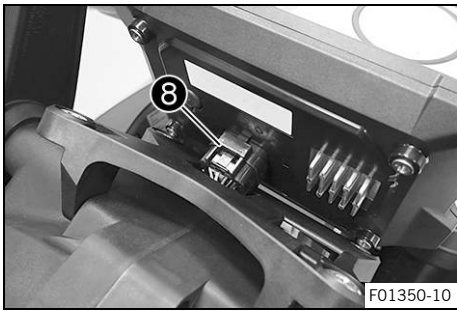

F01350-10

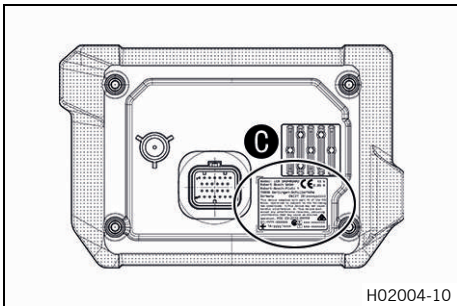

H02004-10

- Remove screws **7** with the sleeves.

i Tip
Adjust the tilt of the combination instrument accordingly.

- Disconnect plug-in connector **8**.

- Apply radio certification sticker to the rear of the combination instrument in area **C**.

i Info
If the function **KTM MY RIDE** is enabled, the sticker must be applied.
If the function **KTM MY RIDE** is not enabled or has been disabled, the sticker must not be applied.

- Join the plug-in connector.
- Mount and tighten the screws with sleeves **7**.

Guideline

Screw, combination instrument	M5	4.5 Nm (3.32 lbf ft)
-------------------------------	----	-------------------------

i Tip
Adjust the tilt of the combination instrument accordingly.

- Position the headlight mask.
- Mount and tighten screws **6**.

Guideline

Screw, cover part	M5	3.5 Nm (2.58 lbf ft)
-------------------	----	-------------------------

- Install the wind shield. (📖 p. 8)
- Remove the Race-on key from the storage compartment and keep in a safe place for the handover.
- Take off the passenger seat. (📖 p. 8)
- Remove black ignition key and the **KEYCODECARD** from under the passenger seat and keep in a safe place for the handover.
- Recharge the battery. (📖 p. 9)
- Remove the remaining films.
- Check the headlight setting. (📖 p. 13)
- Refuel. (📖 p. 17)
- Prepare the vehicle according to the specifications in the **KTM Dealer.net** for handover to the customer.



3.1 Installing the wind shield

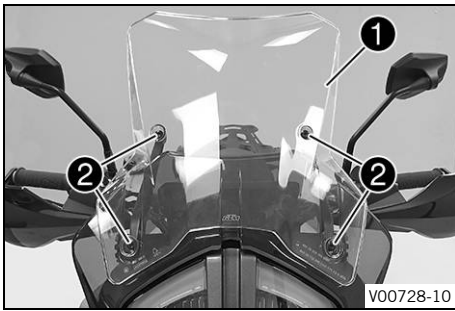

- Position wind shield ①.
- Mount and tighten screws ②.

Guideline

Screw, wind shield	M5	3.5 Nm (2.58 lbf ft)
--------------------	----	-------------------------

3.2 Removing the passenger seat

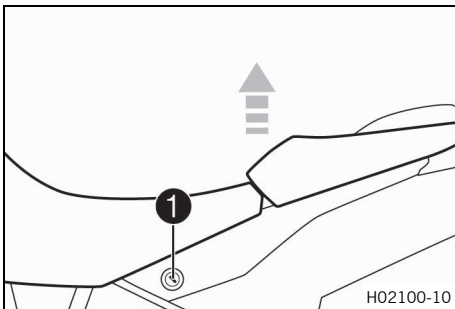

- Insert the Race-on key or the black ignition key into the seat lock ① and turn clockwise.
- Raise front of the passenger seat, pull toward the fuel tank, and take off from above.
- Remove the key.

3.3 Mounting the passenger seat

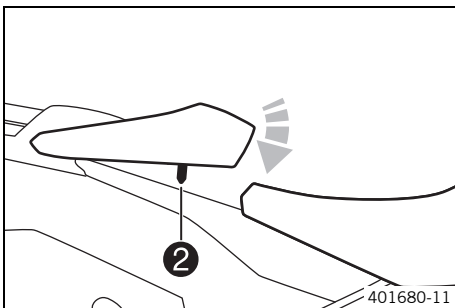

- Attach the hooks on the passenger seat ① to the hanger on the subframe.



Info

Ensure that the seat heating cable is correctly routed.

- Lower passenger seat and push back at the same time.
- Position locking pin ② in lock housing and press passenger seat forward until the locking pin engages with an audible click.
- Check that the passenger seat is correctly mounted.

3.4 Removing the front rider's seat

Preparatory work

- Take off the passenger seat. (🗨 p. 8)

Main work

- Lift the rider's seat back and unhook in the **A** area.

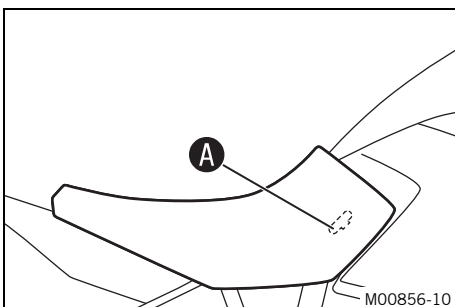

3.5 Mounting the front rider's seat

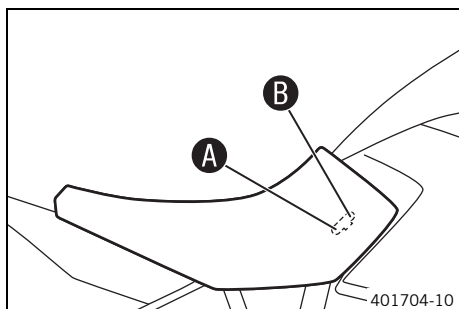

Main work

- Attach the recesses on the front rider's seat to the fuel tank at the desired seat position **A** or **B**, and push the driver's seat forward while lowering it at the rear.
- Finally, check that the front rider's seat is correctly mounted.

Finishing work

- Mount the passenger seat. (🔧 p. 8)



3.6 Recharging the battery



Warning

Risk of injury Battery acid and battery gases cause serious chemical burns.

- Keep batteries out of the reach of children.
- Wear suitable protective clothing and safety glasses.
- Avoid contact with battery acid and battery gases.
- Keep sparks or open flames away from the battery.
- Only charge batteries in well-ventilated rooms.
- Rinse the affected area immediately with plenty of water in the event of contact with the skin.
- Rinse eyes with water for at least 15 minutes and consult a doctor immediately if battery acid and battery gases get into the eyes.



Warning

Environmental hazard Batteries contain environmentally-hazardous materials.

- Do not dispose of batteries as household waste.
- Dispose of batteries at a collection point for used batteries.



Warning

Environmental hazard Hazardous substances cause environmental damage.

- Dispose of oils, grease, filters, fuel, cleaning agents, brake fluid, etc., correctly and in compliance with the applicable regulations.



Info

Even when there is no load on the battery, it discharges steadily. The charging level and the method of charging are very important for the service life of the battery. Rapid recharging with a high charging current shortens the service life of the battery. If the charging current, charging voltage, and charging time are exceeded, the battery will be destroyed. If the battery is depleted from starting the vehicle repeatedly, the battery must be charged immediately. If the battery is left in a discharged state for an extended period, it will become over-discharged and sulfated, destroying the battery. The battery is maintenance-free, i.e., the acid level does not have to be checked.

Preparatory work

- Switch off ignition - to do this briefly press the Race-on button  (maximum of 1 second) with the ignition switched on.
- Take off the passenger seat. (🔧 p. 8)

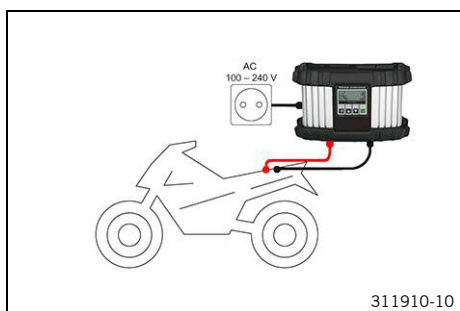

- Remove the front rider's seat. (📖 p. 8)
- Remove the battery. (📖 p. 10)

Main work

- Connect the battery charger to the battery. Adjust the battery charger.

EU battery charger **XCharge-professional** (00029095050)

Alternative 1

US battery charger **XCharge-professional**
(00029095051)

Alternative 2

UK battery charger **XCharge-professional**
(00029095052)

Alternative 3

CH battery charger **XCharge-professional**
(00029095053)



Info

Follow the instructions of the charger and the manual.

- Disconnect the battery charger after charging the battery.

Guideline

The charging current, charging voltage, and charging time must not be exceeded.

Charge the battery regularly when the motorcycle is not in use	3 months
--	----------

Finishing work

- Install the battery. (📖 p. 11)
- Mount the front rider's seat. (📖 p. 9)
- Mount the passenger seat. (📖 p. 8)
- Set the time and date.

3.7 Removing the battery



Warning

Risk of injury Battery acid and battery gases cause serious chemical burns.

- Keep batteries out of the reach of children.
- Wear suitable protective clothing and safety glasses.
- Avoid contact with battery acid and battery gases.
- Keep sparks or open flames away from the battery.
- Only charge batteries in well-ventilated rooms.
- Rinse the affected area immediately with plenty of water in the event of contact with the skin.
- Rinse eyes with water for at least 15 minutes and consult a doctor immediately if battery acid and battery gases get into the eyes.





Caution

Danger of accidents Electronic components and safety devices will be damaged if the battery is discharged or missing.

- Never operate the vehicle with a discharged battery or without a battery.

Preparatory work

- Switch off ignition - to do this briefly press the Race-on button  (maximum of 1 second) with the ignition switched on.
- Take off the passenger seat. ( p. 8)
- Remove the front rider's seat. ( p. 8)

Main work

- Pull locking mechanism **1** in the direction of the arrow.
- Fold open cover **2**.

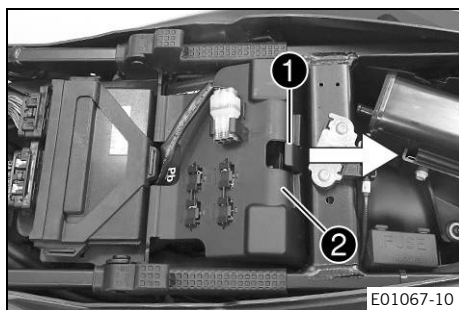

- Disconnect both negative cables **3** from the battery.
- Disconnect both positive cables **4** from the battery.
- Take the battery and battery case **5** out of the battery compartment.

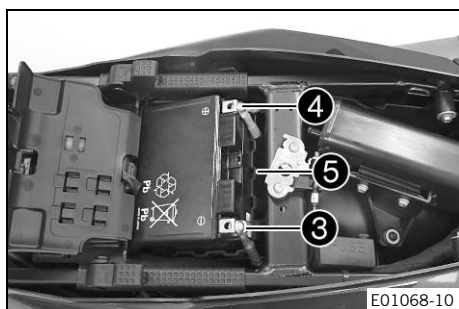

3.8 Installing the battery



Warning

Risk of injury Battery acid and battery gases cause serious chemical burns.

- Keep batteries out of the reach of children.
- Wear suitable protective clothing and safety glasses.
- Avoid contact with battery acid and battery gases.
- Keep sparks or open flames away from the battery.
- Only charge batteries in well-ventilated rooms.
- Rinse the affected area immediately with plenty of water in the event of contact with the skin.
- Rinse eyes with water for at least 15 minutes and consult a doctor immediately if battery acid and battery gases get into the eyes.



Caution

Danger of accidents Electronic components and safety devices will be damaged if the battery is discharged or missing.

- Never operate the vehicle with a discharged battery or without a battery.

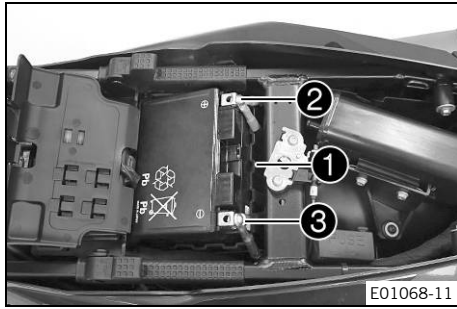

Main work

- Position the battery in battery case ①.

Guideline

The even side of the battery case must be opposite the poles.

- Position the battery and battery case in the battery compartment.
- Position the positive cable ② and mount and tighten the screw.

Guideline

Screw, battery terminal	M6	4.5 Nm (3.32 lbf ft)
-------------------------	----	-------------------------

- Position the negative cable ③ and mount and tighten the screw.

Guideline

Screw, battery terminal	M6	4.5 Nm (3.32 lbf ft)
-------------------------	----	-------------------------

- Close the cover ④ and push down slightly.
 ✓ The cover engages with an audible click.

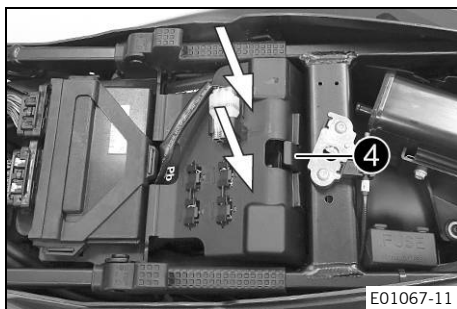

Finishing work

- Mount the front rider's seat. (📖 p. 9)
- Mount the passenger seat. (📖 p. 8)
- Set the time and date.

3.9 Setting the time and date

Condition

The motorcycle is stationary.

- Press the **SET** button when the menu is closed.
- Press the **UP** or **DOWN** button until **Preferences** appears. Press the **SET** button to open the menu.
- Press the **UP** or **DOWN** button until **Time/Date** is marked. Press the **SET** button to open the menu.

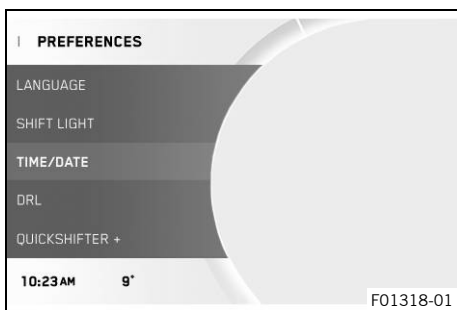

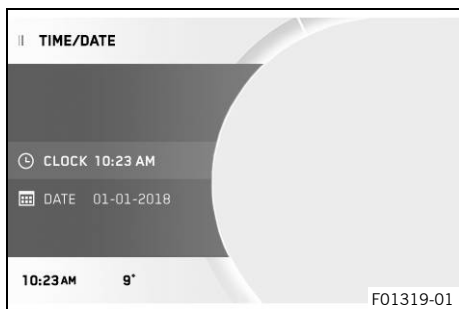

Setting the clock

- Press the **UP** or **DOWN** button until the time is marked.
- Press the **SET** button.
 - ✓ The hour next to **Clock** flashes.
- Press the **UP** or **DOWN** button until the current hour is set.
- Press the **SET** button.
 - ✓ The minute next to **Clock** flashes.
- Press the **UP** or **DOWN** button until the current minute is set.
- Press the **SET** button.
 - ✓ The time is stored.

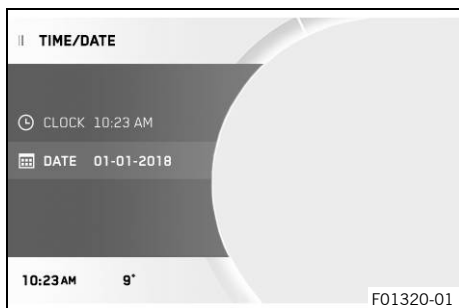

Setting the date

- Press the **UP** or **DOWN** button until the date is marked.
- Press the **SET** button.
 - ✓ The day next to **Date** flashes.
- Press the **UP** or **DOWN** button until the current day is set.
- Press the **SET** button.
 - ✓ The month next to **Date** flashes.
- Press the **UP** or **DOWN** button until the current month is set.
- Press the **SET** button.
 - ✓ The year next to **Date** flashes.
- Press the **UP** or **DOWN** button until the current year is set.
- Press the **SET** button.
 - ✓ The date is stored.



3.10 Checking the headlight setting

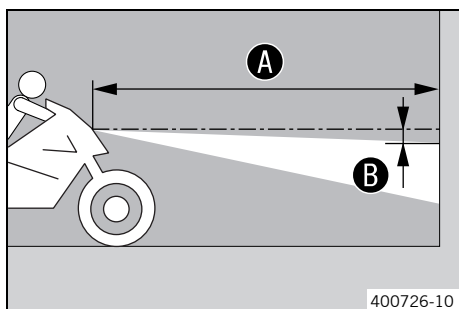

- Park the vehicle on a horizontal surface in front of a light-colored wall and make a mark at the height of the center of the low beam headlight.
- Make another mark at a distance **B** under the first marking.

Guideline

Distance B	5 cm (2 in)
-------------------	-------------

- Position the vehicle perpendicular to the wall at a distance **A** from the wall and switch on the low beam.

Guideline

Distance A	5 m (16 ft)
-------------------	-------------

- The rider, with luggage and passenger if applicable, now mounts the motorcycle.
- Check the headlight setting.

The light-dark boundary must lie exactly on the lower mark when the motorcycle is ready to operate with the rider mounted along with any luggage and a passenger if applicable.

- » If the boundary between light and dark does not meet specifications:

- Adjust the headlight range. (📖 p. 14)

3.11 Adjusting the headlight range

Preparatory work

- Check the headlight setting. (📖 p. 13)

Main work

- Turn adjusting wheel **1** to adjust the headlight range.



Info

Turn counterclockwise to increase the headlight range; turn clockwise to reduce the headlight range. If you have a payload, you may have to correct the headlight range.

- Set the headlight to marking **B**.

Guideline

The light-dark boundary must lie exactly on lower mark **B** when the motorcycle is ready to operate with the rider mounted along with any luggage and a passenger if applicable.

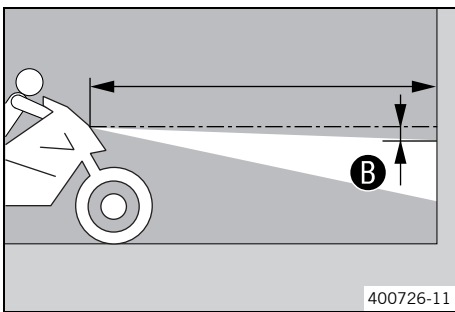

3.12 Starting



Danger

Danger of poisoning Exhaust gases are toxic and inhaling them may result in unconsciousness and death.

- Always make sure there is sufficient ventilation when running the engine.
- Use an effective exhaust extraction system when starting or running the engine in an enclosed space.



Caution

Danger of accidents Electronic components and safety devices will be damaged if the battery is discharged or missing.

- Never operate the vehicle with a discharged battery or without a battery.

Note

Engine damage High revving speed with a cold engine negatively impacts the lifespan of the engine.

- Always run the engine warm at a low speed.

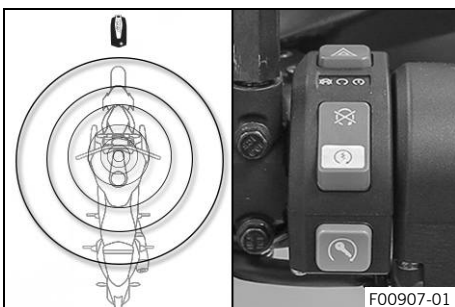

- Take the motorcycle off side stand and sit in the motorcycle.
- Bring the Race-on key within range of the antenna.
- Ensure that the Race-on key stays in range while riding.

Guideline

Maximum range of the Race-on key around the antenna	1.5 m (4.9 ft)
---	----------------

i Info
The range may be reduced by decreases in battery voltage of the Race-on key and interfering radio waves. If the battery voltage of the Race-on key is too low, one of the keys must be held in area of the antenna and must be safely stored again after starting.

- Make sure that the emergency OFF switch/electric starter button is in the middle position ○.
- Switch on ignition; to do this, briefly press the Race-on tip switch ④ (maximum of 1 second).
 - ✓ The steering is unlocked.
 - ✓ The function check of the combination instrument is run.
 - ✓ The ABS indicator lamp goes out when you start off.

i Info
If the handlebar does not unlock, move the handlebar slightly.

- Shift the transmission to idle ⑤.
 - ✓ The green idling speed indicator lamp ⑥ lights up.
- Turn the emergency OFF switch/electric starter button to the lower position ③.

i Info
Do not press the emergency off switch/electric starter button into the lower position ③ until the combination instrument function check has been completed. When starting, **DO NOT** open the throttle. If you open the throttle during the starting procedure, fuel is not injected by the engine management system and the engine cannot start. Press the emergency OFF switch/electric starter button into the lower position ③ for a maximum of 5 seconds. Wait for a least 5 seconds before trying again. This motorcycle is equipped with a safety starting system. You can only start the engine if the transmission is in neutral or if the clutch lever is pulled when a gear is engaged. If the side stand is folded out and you shift into gear, the engine stops.



3.13 Opening the filler cap

! Danger
Fire hazard Fuel is highly flammable.

The fuel in the fuel tank expands when warm and can escape if overfilled.

- Do not refuel the vehicle in the vicinity of open flames or lit cigarettes.
- Switch off the engine for refueling.
- Make sure that no fuel is spilled; particularly not on hot parts of the vehicle.
- If any fuel is spilled, wipe it off immediately.
- Observe the specifications for refueling.



Warning

Danger of poisoning Fuel is poisonous and a health hazard.

- Avoid skin, eye and clothing contact with fuel.
- Immediately consult a doctor if you swallow fuel.
- Do not inhale fuel vapors.
- In case of skin contact, rinse the affected area with plenty of water.
- Rinse the eyes thoroughly with water, and consult a doctor in case of fuel contact with the eyes.
- Change your clothing in case of fuel spills on them.
- Keep fuels correctly in a suitable canister, and out of the reach of children.



Warning

Environmental hazard Improper handling of fuel is a danger to the environment.

- Do not allow fuel to enter the groundwater, the soil, or the sewage system.

Condition

The motorcycle is stationary.

The engine is off.

The ignition has been switched on or off for less than 1 minute.

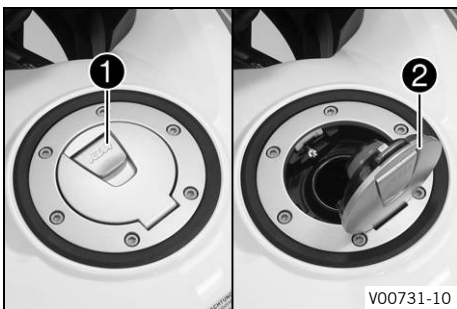

- Fold up cover ① slowly.
- ✓ The filler cap unlocks.
- Fold open filler cap ②.

3.14 Closing the filler cap

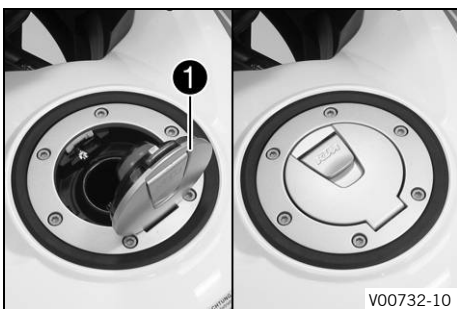

Warning

Fire hazard Fuel is highly flammable, toxic and a health hazard.

- Check the filler cap is locked correctly after closing.
- Change your clothing in case of fuel spills on them.
- Rinse the affected area immediately with plenty of water in the event of contact with the skin.

- Fold down the filler cap ① and push it down.
- ✓ The filler cap locks audibly in place.

3.15 Refueling



Danger

Fire hazard Fuel is highly flammable.

The fuel in the fuel tank expands when warm and can escape if overfilled.

- Do not refuel the vehicle in the vicinity of open flames or lit cigarettes.
- Switch off the engine for refueling.
- Make sure that no fuel is spilled; particularly not on hot parts of the vehicle.
- If any fuel is spilled, wipe it off immediately.
- Observe the specifications for refueling.



Warning

Danger of poisoning Fuel is poisonous and a health hazard.

- Avoid skin, eye and clothing contact with fuel.
- Immediately consult a doctor if you swallow fuel.
- Do not inhale fuel vapors.
- In case of skin contact, rinse the affected area with plenty of water.
- Rinse the eyes thoroughly with water, and consult a doctor in case of fuel contact with the eyes.
- Change your clothing in case of fuel spills on them.

Note

Material damage Inadequate fuel quality causes the fuel filter to quickly become clogged.

In some countries and regions, the available fuel quality and cleanliness may not be sufficient. This will result in problems with the fuel system.

- Refuel only with clean fuel that meets the specified standards.



Warning

Environmental hazard Improper handling of fuel is a danger to the environment.

- Do not allow fuel to enter the groundwater, the soil, or the sewage system.

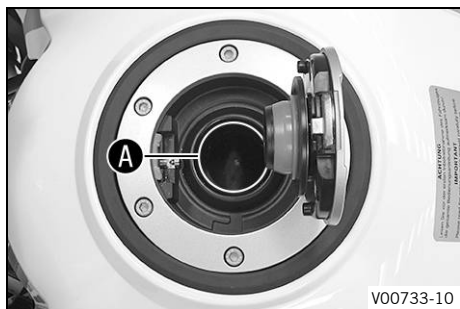

- Switch off the engine.
- Open the filler cap. (📖 p. 15)
- Fill the fuel tank with fuel up to the lower edge **A** of the filler neck.

Total fuel tank capacity, approx.	23 l (6.1 US gal)	Super unleaded (ROZ 95/RON 95/PON 91) (📖 p. 21)
-----------------------------------	----------------------	---

- Close the filler cap. (📖 p. 16)



4 TECHNICAL DATA

4.1 Chassis tightening torques

Screw, combination switch, left		5 Nm (3.7 lbf ft)	
Screw, headlight	EJOT Altracs® 60x20	8 Nm (5.9 lbf ft)	
Screw, headlight holder	EJOT Altracs® 50x12	7 Nm (5.2 lbf ft)	
Screw, fixed grip, left	M4	2 Nm (1.5 lbf ft)	
Screw, side stand switch	M4	2 Nm (1.5 lbf ft)	
Remaining nuts, chassis	M5	5 Nm (3.7 lbf ft)	
Remaining screws, chassis	M5	5 Nm (3.7 lbf ft)	
Screw for throttle grip	M5	3.5 Nm (2.58 lbf ft)	
Screw, brake line holder on frame	M5	2 Nm (1.5 lbf ft)	
Screw, brake line holder on swingarm	M5	5 Nm (3.7 lbf ft)	
Screw, cable channel	M5	5 Nm (3.7 lbf ft)	
Screw, cable guide, wheel speed sensor, rear	M5	3 Nm (2.2 lbf ft)	
Screw, chain sliding guard	M5	5 Nm (3.7 lbf ft)	
Screw, combination instrument	M5	4.5 Nm (3.32 lbf ft)	
Screw, combination switch, right	M5	5 Nm (3.7 lbf ft)	
Screw, cover part	M5	3.5 Nm (2.58 lbf ft)	
Screw, cover part	M5x12	3.5 Nm (2.58 lbf ft)	
Screw, cover part	M5x17	3.5 Nm (2.58 lbf ft)	
Screw, cross member for luggage support (EU/JP/CN)	M5	4 Nm (3 lbf ft)	
Screw, filler cap	M5	3 Nm (2.2 lbf ft)	
Screw, foot brake lever stub	M5	6 Nm (4.4 lbf ft)	Loctite®243™
Screw, fuel level sensor	M5	3 Nm (2.2 lbf ft)	
Screw, heat guard on main silencer	M5	4 Nm (3 lbf ft)	
Screw, wind shield	M5	3.5 Nm (2.58 lbf ft)	
Ground fitting on frame	M6	6 Nm (4.4 lbf ft)	
Nut, ABS module fastening	M6	8 Nm (5.9 lbf ft)	
Remaining chassis nuts	M6	10 Nm (7.4 lbf ft)	
Remaining chassis screws	M6	10 Nm (7.4 lbf ft)	
Screw, angle sensor	M6	6 Nm (4.4 lbf ft)	Loctite®243™
Screw, ball joint of push rod on foot brake cylinder	M6	10 Nm (7.4 lbf ft)	Loctite®243™
Screw, battery terminal	M6	4.5 Nm (3.32 lbf ft)	
Screw, bushing	M6	4 Nm (3 lbf ft)	
Screw, cable channel	M6	5 Nm (3.7 lbf ft)	
Screw, chain guide	M6	5 Nm (3.7 lbf ft)	
Screw, clutch assembly	M6	5 Nm (3.7 lbf ft)	
Screw, cooler retaining bracket	M6	7 Nm (5.2 lbf ft)	
Screw, cover part	M6	6 Nm (4.4 lbf ft)	
Screw, engine guard	M6	10 Nm (7.4 lbf ft)	
Screw, exhaust clamp	M6	8 Nm (5.9 lbf ft)	

Screw, foot brake cylinder	M6	10 Nm (7.4 lbf ft) Loctite®243™
Screw, front brake disc	M6	14 Nm (10.3 lbf ft) Loctite®243™
Screw, front wheel speed sensor	M6	10 Nm (7.4 lbf ft)
Screw, fuel pump	M6	6 Nm (4.4 lbf ft)
Screw, fuel tank	M6	10 Nm (7.4 lbf ft)
Screw, fuel tap	M6	6 Nm (4.4 lbf ft)
Screw, handlebar clamp hand guard	M6	5 Nm (3.7 lbf ft)
Screw, lower rear part	M6	6 Nm (4.4 lbf ft)
Screw, magnetic holder on side stand	M6	6 Nm (4.4 lbf ft) Loctite®243™
Screw, rear brake disc	M6	14 Nm (10.3 lbf ft) Loctite®243™
Screw, retaining bracket, angle sensor	M6	10 Nm (7.4 lbf ft)
Screw, voltage regulator	M6	6 Nm (4.4 lbf ft)
Screw, wheel speed sensor, rear	M6	10 Nm (7.4 lbf ft)
Angled valve (EU/US/CN)	M8	6 Nm (4.4 lbf ft)
Angled valve (JP)	M8	4 Nm (3 lbf ft)
Remaining chassis nuts	M8	25 Nm (18.4 lbf ft)
Remaining chassis screws	M8	25 Nm (18.4 lbf ft)
Screw, bottom triple clamp	M8	12 Nm (8.9 lbf ft)
Screw, exhaust clamp	M8	25 Nm (18.4 lbf ft)
Screw, foot brake lever	M8	25 Nm (18.4 lbf ft) Loctite®243™
Screw, fork stub	M8	15 Nm (11.1 lbf ft)
Screw, front footrest bracket	M8	25 Nm (18.4 lbf ft) Loctite®243™
Screw, handle bar end hand guard	M8	25 Nm (18.4 lbf ft)
Screw, handlebar clamp	M8	20 Nm (14.8 lbf ft)
Screw, ignition lock (tamper-proof screw)	M8	25 Nm (18.4 lbf ft) Loctite®243™
Screw, rail fitting (EU/JP/CN)	M8	20 Nm (14.8 lbf ft) Loctite®243™
Screw, rear footrest bracket	M8	25 Nm (18.4 lbf ft) Loctite®243™
Screw, steering damper	M8	25 Nm (18.4 lbf ft) Loctite®243™
Screw, steering damper clamp	M8	12 Nm (8.9 lbf ft)
Screw, steering stem	M8	20 Nm (14.8 lbf ft)
Screw, suitcase hook	M8	20 Nm (14.8 lbf ft) Loctite®243™
Screw, top triple clamp	M8	20 Nm (14.8 lbf ft)
Remaining chassis nuts	M10	45 Nm (33.2 lbf ft)
Remaining chassis screws	M10	45 Nm (33.2 lbf ft)

4 TECHNICAL DATA

Screw, front brake caliper	M10	45 Nm (33.2 lbf ft) Loctite®243™
Screw, handlebar support	M10	40 Nm (29.5 lbf ft) Loctite®243™
Screw, side stand	M10	35 Nm (25.8 lbf ft) Loctite®243™
Screw, side stand bracket	M10	45 Nm (33.2 lbf ft) Loctite®243™
Banjo bolt, brake line	M10x1	25 Nm (18.4 lbf ft)
Nut, rear sprocket screw	M10x1.25	50 Nm (36.9 lbf ft) Loctite®243™
Lambda sensor	M12x1.25	25 Nm (18.4 lbf ft)
Screw, bottom shock absorber	M14x1.5	80 Nm (59 lbf ft) Thread greased
Screw, top shock absorber	M14x1.5	80 Nm (59 lbf ft) Thread greased
Nut, socket	M18x1	4 Nm (3 lbf ft)
Nut, swingarm pivot	M19x1.5	130 Nm (95.9 lbf ft) Thread greased
Nut, seat lock	M22x1.5	4 Nm (3 lbf ft)
Screw, steering head, top	M22x1.5	18 Nm (13.3 lbf ft)
Nut, rear wheel spindle	M25x1.5	90 Nm (66.4 lbf ft) Thread greased
Screw, front wheel spindle	M25x1.5	45 Nm (33.2 lbf ft) Thread greased

Super unleaded (ROZ 95/RON 95/PON 91)**Standard/classification**

- DIN EN 228 (ROZ 95/RON 95/PON 91)

Guideline

- Only use unleaded super fuel that matches or is equivalent to the specified fuel grade.
- Fuel with an ethanol content of up to 10 % (E10 fuel) is safe to use.

**Info**

Do **not** use fuel containing methanol (e. g. M15, M85, M100) or more than 10 % ethanol (e. g. E15, E25, E85, E100).

READY TO RACE

>> www.ktm.com



3213785en

11/2017



KTM

KTM Sportmotorcycle GmbH
5230 Mattighofen/Austria
<http://www.ktm.com>



KTM Group Partner



REG. NO. 12 100 6061

Photo: Mitterbauer/KTM