

150 EXC TPI 150 XC-W TPI

Art. no. 3214036en



The KTM logo, consisting of the letters 'KTM' in a bold, italicized, sans-serif font, is positioned on an orange rectangular background in the bottom right corner of the page.

Perform the work described in these setup instructions before the vehicle is delivered to the customer.

Read the setup instructions in their entirety before beginning work.

These setup instructions were written to correspond to the latest state of this series. We reserve the right to make changes in the interest of technical advancement without at the same time updating this manual. We shall not provide a description of general workshop methods. Likewise, safety rules that apply in a workshop are not specified here. It is assumed that the work will be performed by a fully trained mechanic.

All specifications contained are non-binding. KTM Sportmotorcycle GmbH specifically reserves the right to modify or delete technical specifications, prices, colors, forms, materials, services, designs, equipment, etc., without prior notice and without specifying reasons, to adapt these to local conditions, as well as to stop production of a particular model without prior notice. KTM accepts no liability for delivery options, deviations from figures and descriptions, misprints, and other errors. The models portrayed partly contain special equipment that does not belong to the regular scope of supply.

© 2019 KTM Sportmotorcycle GmbH, Mattighofen Austria

All rights reserved

Reproduction, even in part, as well as copying of all kinds, is permitted only with the express written permission of the copyright owner.



ISO 9001(12 100 6061)

KTM applies quality assurance processes that lead to the highest possible product quality as defined in the ISO 9001 international quality management standard.

Issued by: TÜV Management Service

REG.NO. 12 100 6061

KTM Sportmotorcycle GmbH

Stallhofnerstraße 3

5230 Mattighofen, Austria

This document is valid for the following models:

150 EXC TPI EU (F7103T6)

150 XC-W TPI US (F7175T3)



1 MEANS OF REPRESENTATION

1.1 Symbols used

The meaning of specific symbols is described below.



Indicates an expected reaction (e.g. of a work step or a function).



Indicates an unexpected reaction (e.g. of a work step or a function).



Indicates a page reference (more information is provided on the specified page).



Indicates information with more details or tips.



Indicates the result of a testing step.



Indicates a voltage measurement.



Indicates a current measurement.



Indicates a resistance measurement.



Indicates the end of an activity including potential rework.

1.2 Formats used

The typographical formats used in this document are explained below.

Proprietary name

Indicates a proprietary name.

Name®

Indicates a protected name.

Brand™

Indicates a brand available on the open market.

Underlined terms

Refer to technical details of the vehicle or indicate technical terms, which are explained in the glossary.

2.1 Transport mode

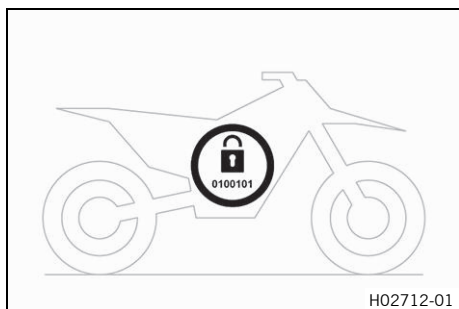

This vehicle was blocked for transport in the software. To operate the vehicle, the vehicle electronics must be enabled. This process is conducted during initial setup in KTM Dealer.net. Enabling ensures that the initial setup in KTM Dealer.net is documented.

Enabling can be performed either temporarily, e.g. for a test ride, or permanently for vehicle handover.



Info

Make sure that the vehicle is permanently enabled before handing it over to the customer.

2.2 Unpacking and setting up the vehicle

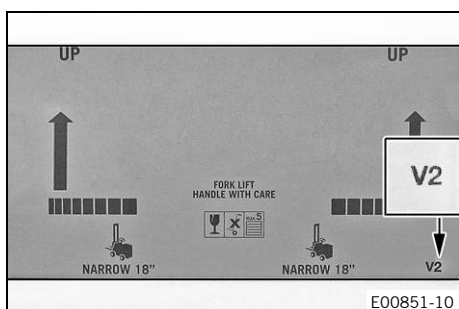

Condition

Packaging V2

- Remove the box and the plastic packaging.



Info

An assistant prevents the motorcycle from falling over. To avoid damaging the motorcycle during the setup, leave the protective film on the vehicle until you have finished.

- Remove the separate enclosure and unpack it. Check that the scope of supply is complete using the enclosed packing list.
- Have a lift stand available.

Lift stand (78129955100)

- Carefully loosen and remove the tension belt of the footrest mount.



Info

An assistant prevents the motorcycle from falling over.

- Together with an assistant, take the vehicle off the pallet.
- Position the vehicle on a lift stand.
- Check the vehicle for transport damage.
- Remove the headlight mask with the headlight. (📖 p. 32)

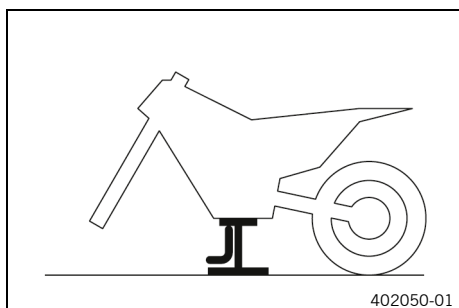

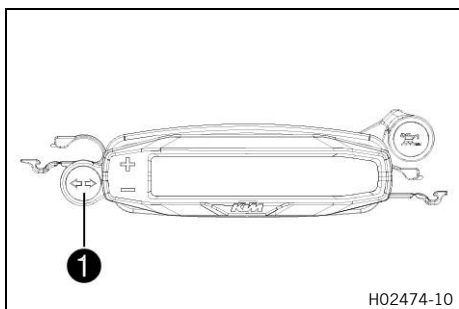

(150 EXC TPI EU)

- Position the turn signal indicator lamp **1** in the combination instrument bracket.

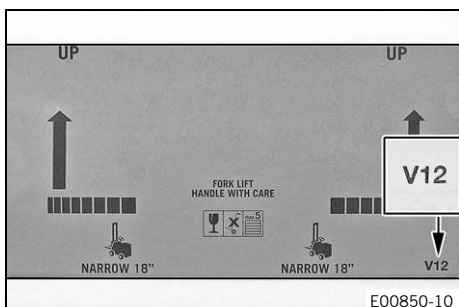

Condition

Packaging V12

- Remove the box and the plastic packaging.



Info

An assistant prevents the motorcycle from falling over. To avoid damaging the motorcycle during the setup, leave the protective film on the vehicle until you have finished.

- Remove and unpack the separate enclosure and components. Check that the scope of supply is complete using the enclosed packing list.
- Have a lift stand available.

Lift stand (78129955100)

- Remove the two cable ties on the triple clamp.
- Together with an assistant, take the vehicle off the pallet.
- Position the vehicle on a lift stand.
- Check the vehicle and components for transport damage.
- Install the shock absorber. (📖 p. 22)

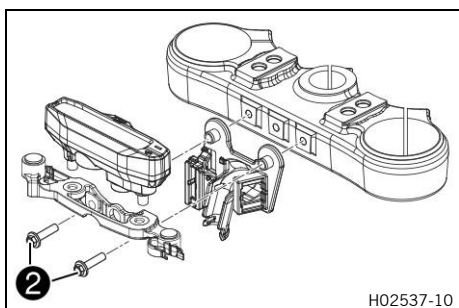
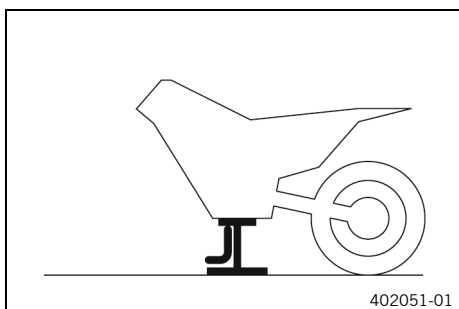

(150 EXC TPI EU)

- Position the connector retainer and combination instrument on the upper triple clamp.
- Mount and tighten screws **2**.

Guideline

Remaining screws, chassis	M6	10 Nm (7.4 lbf ft)
---------------------------	----	-----------------------

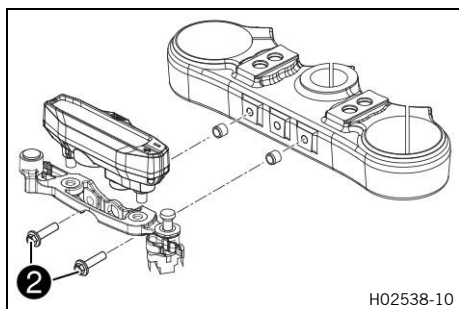

H02538-10

(150 XC-W TPI US)

- Position the combination instrument on the upper triple clamp.
- Mount and tighten screws **2** with the collar bushings.

Guideline

Remaining screws, chassis	M6	10 Nm (7.4 lbf ft)
---------------------------	----	-----------------------

- Route the clutch line with the clutch master cylinder toward the front between the upper and lower triple clamps.
- Install the fork legs. (📖 p. 23)

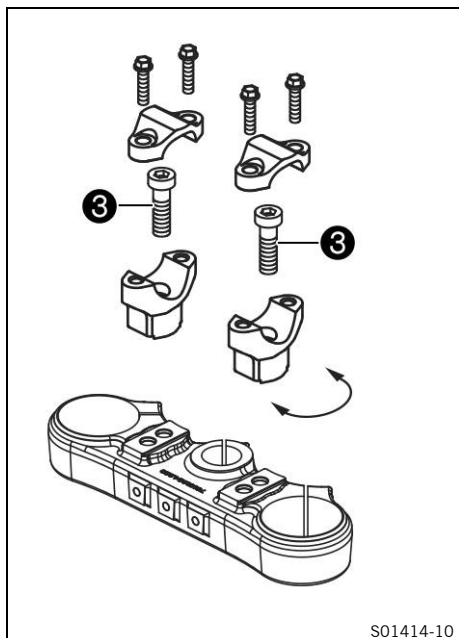

S01414-10

- Remove screws **3** and take off the handlebar supports.
- Move the handlebar supports to the desired position and mount and tighten screws **3**.

Guideline

Screw, handlebar support	M10	40 Nm (29.5 lbf ft) Loctite®243™
--------------------------	-----	--



Info

Position the left and right handlebar supports evenly.



E00483-01



Warning

Danger of accidents A repaired handlebar poses a safety risk.

If the handlebar is bent or straightened, the material becomes fatigued. The handlebar may break as a result.

- Change the handlebar if the handlebar is damaged or bent.

- Position the handlebar.



Info

Make sure the cables and wiring are positioned correctly.

- Position the handlebar clamps. Mount and tighten the screws evenly.

Guideline

Screw, handlebar clamp	M8	20 Nm (14.8 lbf ft)
------------------------	----	---------------------



Info

The markings on the handlebar should be at the center of the handlebar clamps.
Keep the installed gap widths equal when tightening.



(150 EXC TPI EU)

- Position the controls on the right half of the handlebar.



(150 XC-W TPI US)

- Position the controls on the right half of the handlebar.



(150 EXC TPI EU)

- Position the controls on the left handlebar half.



(150 XC-W TPI US)

- Position the controls on the left handlebar half.

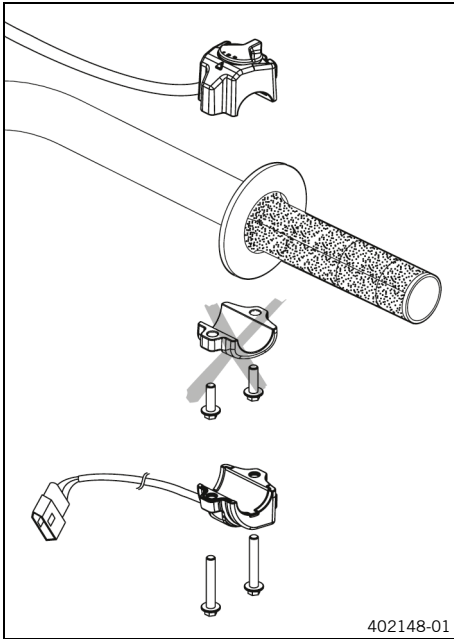

(150 EXC TPI EU)

- Mount the turn signal switch.

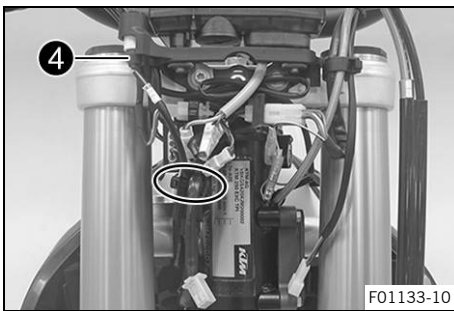

Condition

Packaging V12

(150 EXC TPI EU)

- Insert indicator lamp 4 in the socket.
- Join all plug-in connectors to the plug-in holder.
- Route the cable without tension and secure with cable ties.

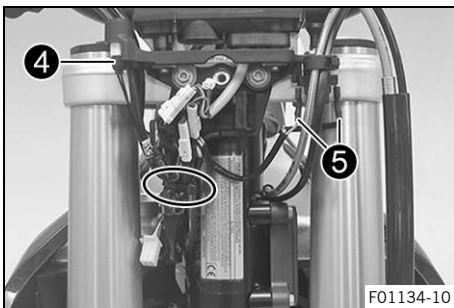

(150 XC-W TPI US)

- Insert indicator lamp 4 in the socket.
- Plug in light pull switch 5 with the yellow and white cables.
- Join all plug-in connectors.
- Route the cable without tension and secure with cable ties.



- Route the cable without tension and secure with cable ties and cable holders.

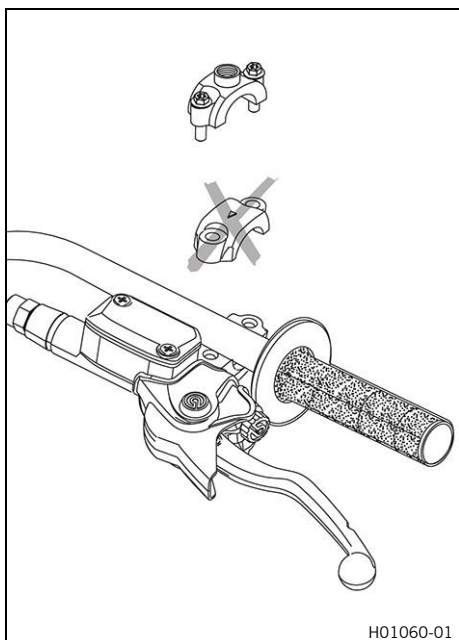

(150 EXC TPI EU)

- Mount the mirror clamps on both sides.

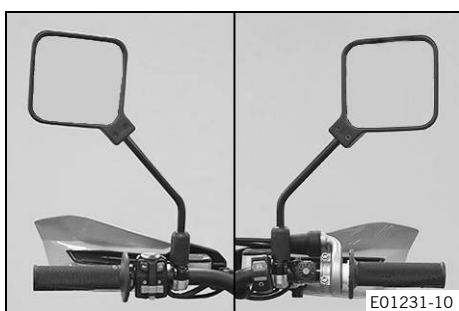

- Mount both rear mirrors with the adapter.

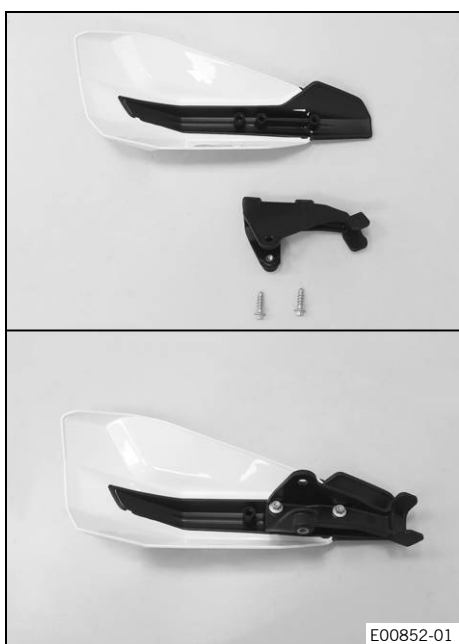

- Preassemble the hand guards on the left and right.



- Mount the left hand guard.
- Mount the right hand guard.



S03689-10

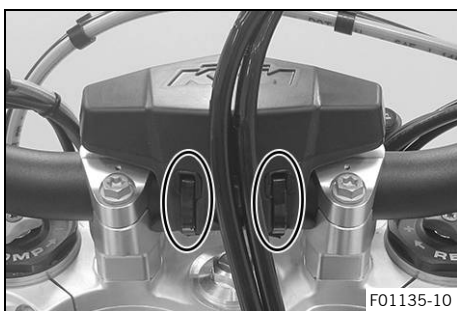

F01135-10

- Secure the handlebar cushion with two cable ties.
- Install front fender. (📖 p. 32)
- Install the front wheel. (📖 p. 23)
- Remove the 12-V battery. (📖 p. 24)
- Charge the 12-V battery. (📖 p. 26)

(150 XC-W TPI US)

- Install the headlight mask with the headlight. (📖 p. 33)
- Install the 12-V battery. (📖 p. 28)

(150 EXC TPI EU)

- Remove connector **6** from the bracket and join with turn signal wiring harness.

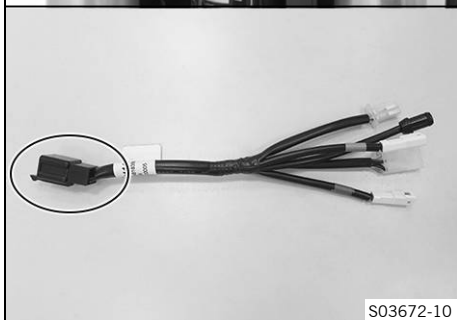
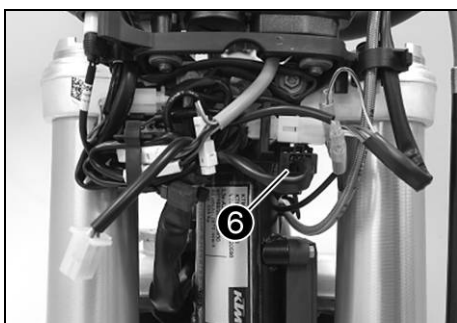

S03672-10

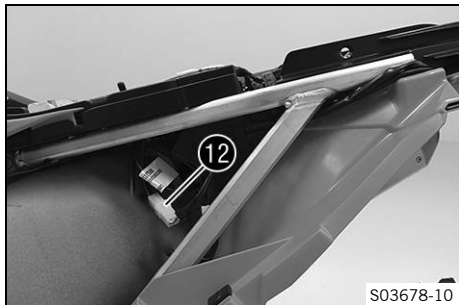
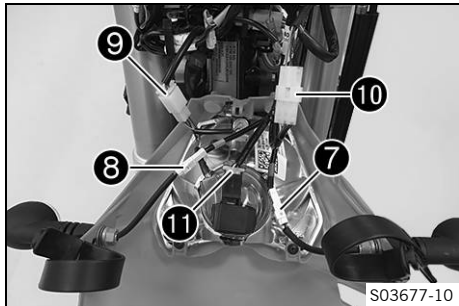
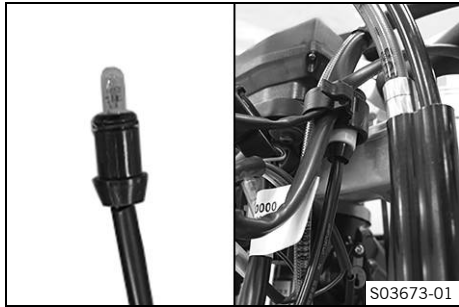

- Insert the black and violet cables of bulb included in the separate enclosure into the socket and position it in the turn signal indicator lamp.
- Position the turn signal on the headlight mask on both sides, mount nuts with washers and tighten.
- Join plug-in connector **7** of the left turn signal using the violet and brown cable colors of the turn signal cable harness.
- Connect the plug-in connector **8** of the right turn signal using the black and brown cable colors of the turn signal cable harness.
- Join plug-in connector **9** of the headlight.
- Connect plug-in connector **10** of the turn signal switch.
- Secure turn signal relay **11** with a cable tie and plug in the connector.
- Install the headlight mask with the headlight. (📖 p. 33)
- Remove the air filter box cover. (📖 p. 30)
- Remove the rear left side cover. (📖 p. 31)
- Disconnect tail light plug-in connector **12** on the wiring harness.



- Remove screws 13.
- Remove screws 14.
- Remove the license plate holder with the tail light.



Info

Pay attention to the cable of the tail light.

- Feed the cable between the fairing parts.

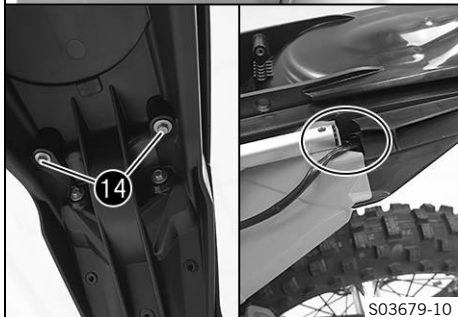

- Remove screws 15 on the license plate holder and hang the tail light to the side.



- Position the turn signal on both sides on the license plate holder, mount nuts with washers and tighten.
- Position license plate lamp on the license plate holder, and mount and tighten screws 16.
- Mount reflector 17 on license plate holder.

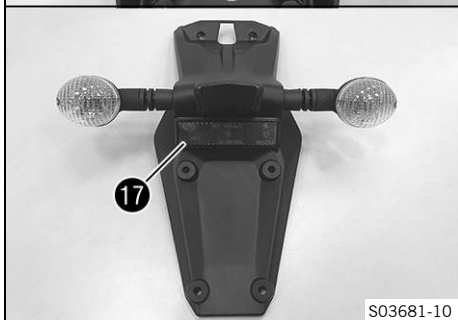



- Drill a hole at marking **A** on the license plate holder to the size of the marking.



- Position the tail light together with the license plate holder on the license plate bracket.

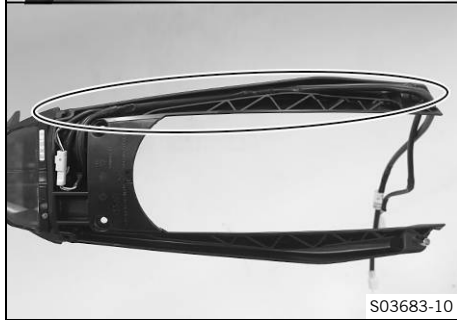

i Info
Ensure that the cables are routed correctly.



- Mount and tighten screws **15**.

Guideline

Remaining screws, chassis	EJOT PT® K60x25-Z	2 Nm (1.5 lbf ft)
---------------------------	-----------------------------	-------------------



- Mount and tighten screw **18**.

Guideline

Remaining screws, chassis	EJOT PT® K60x25-Z	2 Nm (1.5 lbf ft)
---------------------------	-----------------------------	-------------------



- Feed the wiring harnesses through the opening.
- Position the license plate holder on the rear.



- Mount and tighten screw 13 with the collar bushing.

Guideline

Remaining screws, chassis	M6	10 Nm (7.4 lbf ft)
---------------------------	----	--------------------

- Mount and tighten screw 14.

Guideline

Remaining screws, chassis	EJOT PT® K60x25-Z	2 Nm (1.5 lbf ft)
---------------------------	-----------------------------	-------------------

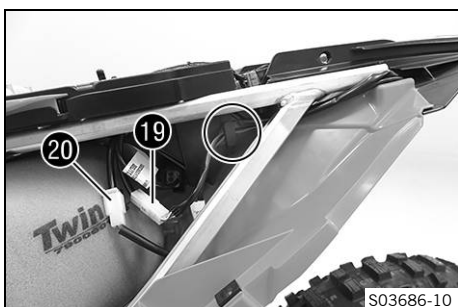

- Join the plug-in connectors of tail light 19 and turn signal wiring harness 20 with the wiring harness.



Info

Pay attention to routing of the wiring harnesses.

- Install the rear left side cover. (📖 p. 31)
- Install the air filter box cover. (📖 p. 30)
- Install the 12-V battery. (📖 p. 28)



- Position the right footrest and pin.



Info

Only insert the pin to the extent that the spring can still be mounted.

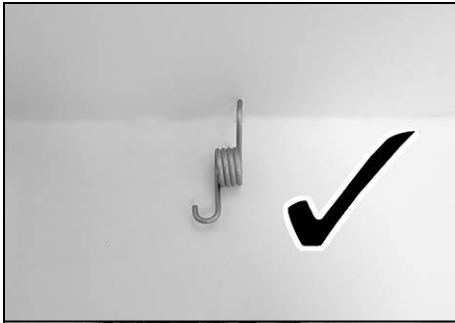

- Position spring as shown.
- ✓ Spring **B** engages in area **C**.

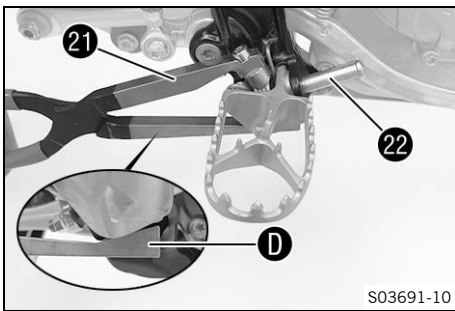
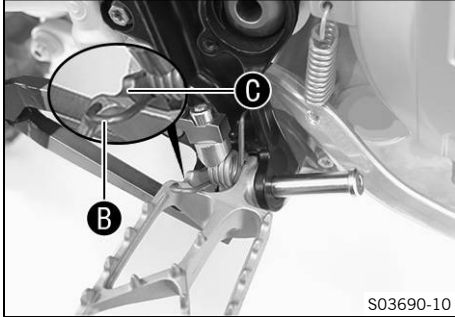

- Press the spring with special tool **21**.

Footrest spring plier (79029083000)

- ✓ The special tool is applied to area **D** on the footrest.
- Mount pin **22**.

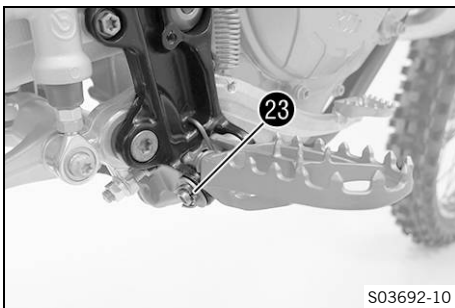

- Mount the washer and splint **23**.

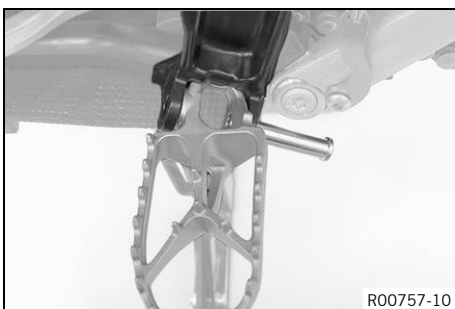

- Position the left footrest and pin.



Info

Only insert the pin to the extent that the spring can still be mounted.

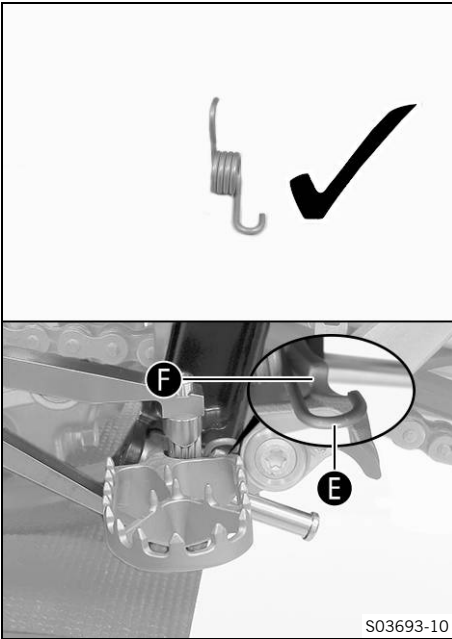

- Position spring as shown.
- ✓ Spring **E** engages in area **F**.

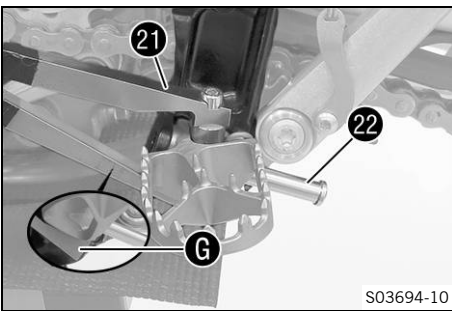

- Press the spring with special tool **21**.
- | |
|-------------------------------------|
| Footrest spring plier (79029083000) |
|-------------------------------------|
- ✓ The special tool is applied to area **G** on the footrest.
 - Mount pin **22**.

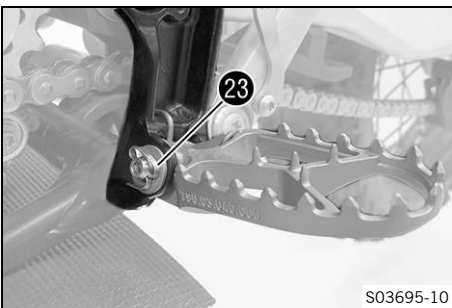

- Mount the washer and splint **23**.

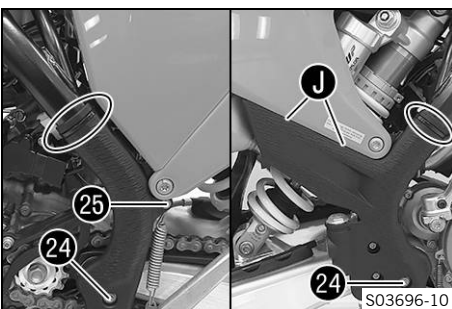

- Position the frame protectors on both sides.
- Hook in the frame protector in area **J**.
- Mount and tighten screws **24**.

Guideline

Screw, frame protector	M5	3 Nm (2.2 lbf ft)
------------------------	----	-------------------

- Mount and tighten screws **25** with the washers.

Guideline

Screw, frame protector	M5	3 Nm (2.2 lbf ft)
------------------------	----	-------------------

- Mount the cable ties.
- Install the engine guard. (📖 p. 35)

- Unpack and mount the **KTM PowerParts** included in the delivery (optional).

**Info**

Read the accompanying **KTM PowerParts** fitting instructions.

- Make sure that the reflectors are glued on to the left and right fork leg.

**Info**

The reflectors must not be covered by trim parts.

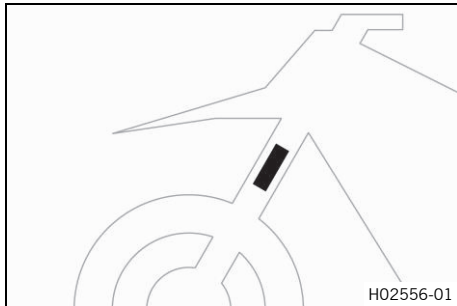

- Attach the stickers included in the scope of supply (optional).
- Set the kilometers or miles. (📖 p. 38)
- Adjust combination instrument function. (📖 p. 39)
- Set the clock. (📖 p. 39)
- Add 2-stroke oil. (📖 p. 35)
- Refuel. (📖 p. 37)
- Position all controls in their exact positions on the handlebar. Tighten all screws.
- Remove the remaining plastic packaging, corrugated cardboard, and other packaging material.
- Prepare the vehicle according to the specifications in **KTM Dealer.net** for handover to the customer.

**Info**

Transport mode must be deactivated to be able to start the motorcycle.

3.1 Raising the motorcycle with a lift stand

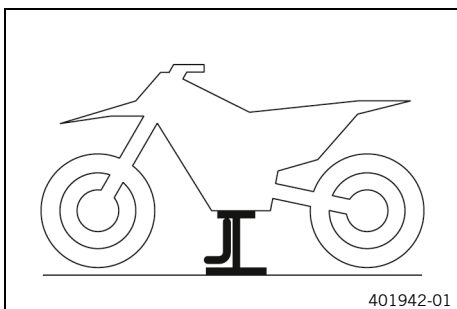

Note

Danger of damage The parked vehicle can roll away or fall over.

- Park the vehicle on a firm and level surface.
- Raise the motorcycle at the frame underneath the engine.

Lift stand (78129955100)

- ✓ Neither wheel is in contact with the ground.
- Secure the motorcycle against falling over.



3.2 Removing the motorcycle from the lift stand

Note

Danger of damage The parked vehicle can roll away or fall over.

- Park the vehicle on a firm and level surface.

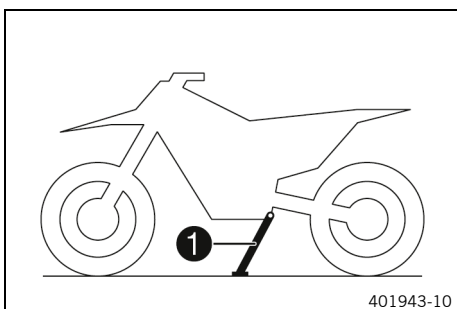

- Remove the motorcycle from the lift stand.
- Remove the lift stand.
- To park the motorcycle, press side stand ① to the ground with your foot and lean the motorcycle on it.

i Info

When you are riding, the side stand must be folded up and secured with the rubber strap.



3.3 Removing the seat

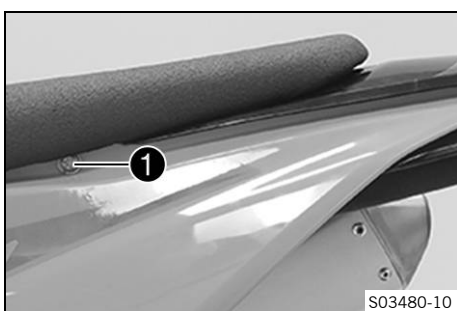

- Remove screws ① on the left side.

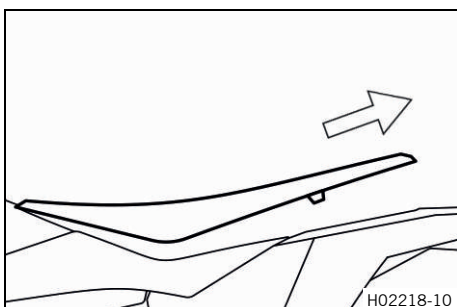

- Raise the rear of the seat, pull the seat back, and lift it off.



3.4 Mounting the seat

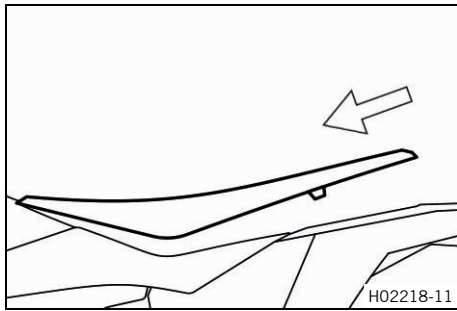

- Mount the front of the seat on the two collar bushings of the fuel tank, lower the seat at the rear, and push the seat forward.
- Make sure the seat is latched in place correctly.

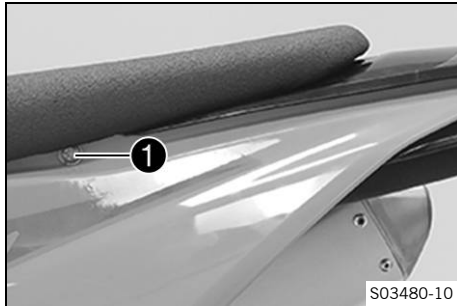

- Mount and tighten screw ❶ on the left side.

Guideline

Remaining screws, chassis	M6	10 Nm (7.4 lbf ft)
---------------------------	----	--------------------

3.5 Removing the fuel tank



Danger

Fire hazard Fuel is highly flammable.

The fuel in the fuel tank expands when warm and can escape if overfilled.

- Do not refuel the vehicle in the vicinity of open flames or lit cigarettes.
- Switch off the engine for refueling.
- Make sure that no fuel is spilled; particularly not on hot parts of the vehicle.
- If any fuel is spilled, wipe it off immediately.
- Observe the specifications for refueling.



Warning

Danger of poisoning Fuel is poisonous and a health hazard.

- Avoid skin, eye and clothing contact with fuel.
- Immediately consult a doctor if you swallow fuel.
- Do not inhale fuel vapors.
- In case of skin contact, rinse the affected area with plenty of water.
- Rinse the eyes thoroughly with water, and consult a doctor in case of fuel contact with the eyes.
- Change your clothing in case of fuel spills on them.
- Keep fuels correctly in a suitable canister, and out of the reach of children.

Preparatory work

- Remove the seat. (📖 p. 17)

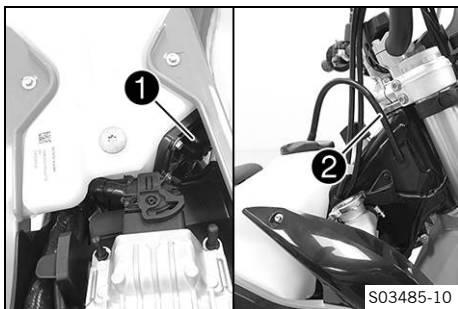

Main work

- Unplug connector **1** of the fuel pump.
- Remove tube **2** from the fuel tank breather.

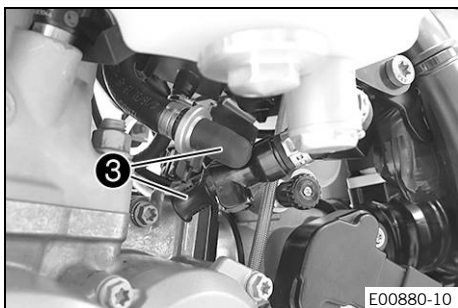

- Thoroughly clean the plug-in connection of the fuel line using compressed air.

i Info
Under no circumstances should dirt enter into the fuel line. Dirt in the fuel line clogs the injection valve!

- Disconnect the plug-in connection of the fuel line.

i Info
Remaining fuel may flow out of the fuel hose.

- Mount wash cap set **3**.

Wash cap set (81212016100)

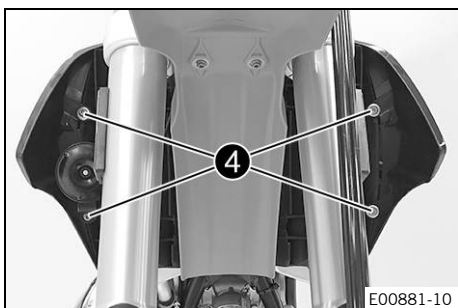

- Remove screws **4** with the collar bushings.
(150 EXC TPI EU)
 - Hang the horn and horn bracket to one side.

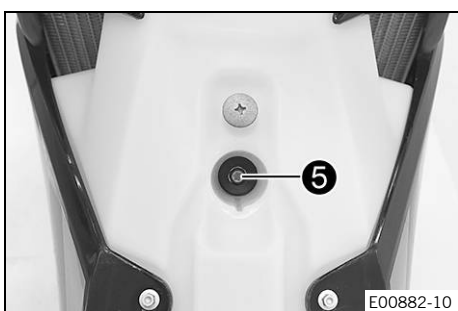

- Remove screw **5** with the rubber bushing.

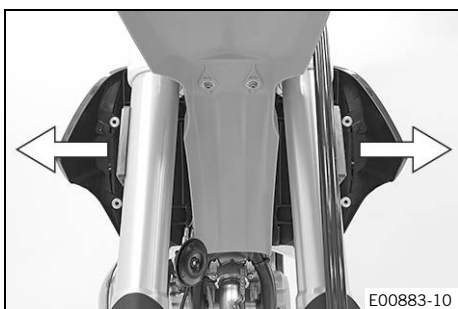

- Pull both spoilers off laterally from the radiator mount and lift off the fuel tank.

3.6 Installing the fuel tank



Danger

Fire hazard Fuel is highly flammable.

The fuel in the fuel tank expands when warm and can escape if overfilled.

- Do not refuel the vehicle in the vicinity of open flames or lit cigarettes.
- Switch off the engine for refueling.
- Make sure that no fuel is spilled; particularly not on hot parts of the vehicle.
- If any fuel is spilled, wipe it off immediately.
- Observe the specifications for refueling.



Warning

Danger of poisoning Fuel is poisonous and a health hazard.

- Avoid skin, eye and clothing contact with fuel.
- Immediately consult a doctor if you swallow fuel.
- Do not inhale fuel vapors.
- In case of skin contact, rinse the affected area with plenty of water.
- Rinse the eyes thoroughly with water, and consult a doctor in case of fuel contact with the eyes.
- Change your clothing in case of fuel spills on them.

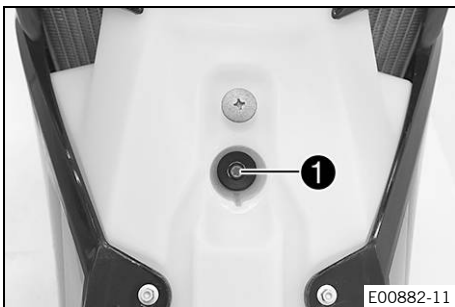
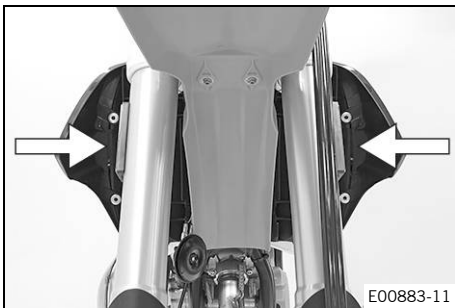

Main work

- Check throttle cable routing. (📖 p. 21)
- Position the fuel tank and fit the two spoilers to the sides in front of the radiator bracket.
- Make sure that no cables or throttle cables are trapped or damaged.

- Mount and tighten screw ❶ with the rubber bushing.

Guideline

Remaining screws, chassis	M6	10 Nm (7.4 lbf ft)
---------------------------	----	--------------------

(150 EXC TPI EU)

- Position the horn with the horn bracket.

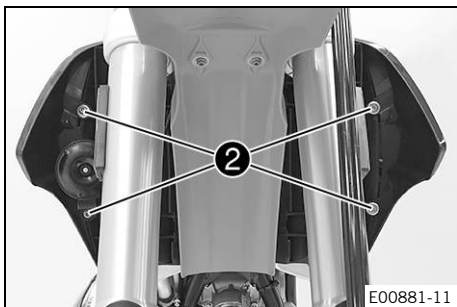

- Mount and tighten screws **2** with the collar bushings.

Guideline

Remaining screws, chassis	M6	10 Nm (7.4 lbf ft)
---------------------------	----	--------------------



- Remove the wash cap set.
- Thoroughly clean the plug-in connection of the fuel line using compressed air.

i Info
Under no circumstances should dirt enter into the fuel line. Dirt in the fuel line clogs the injection valve!

- Lubricate the O-ring and connect plug-in connection **3** for the fuel line.

i Info
Route the cable and fuel line at a safe distance from the exhaust system.

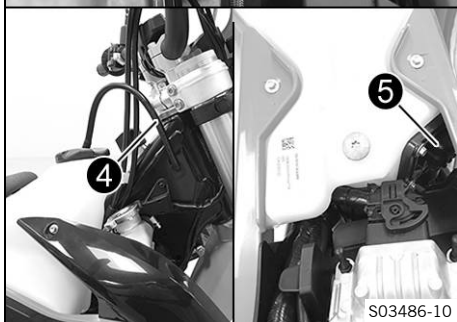

- Attach fuel tank breather hose **4**.
- Plug in connector **5** for the fuel pump.

Finishing work

- Mount the seat. (📖 p. 18)

3.7 Checking throttle cable routing

Preparatory work

- Remove the seat. (📖 p. 17)
- Remove the fuel tank. (📖 p. 18)



Main work

- Check throttle cable routing.

Both throttle cables must be routed, side by side, on the back of the handlebars, above the fuel tank bracket on the right of the frame to the throttle valve body. Both throttle cables must be secured behind the rubber strap of the fuel tank support.

- » If the throttle cable routing is not as specified:
 - Correct throttle cable routing.

Finishing work

- Install the fuel tank. (📖 p. 20)
- Mount the seat. (📖 p. 18)

3.8 Installing the shock absorber

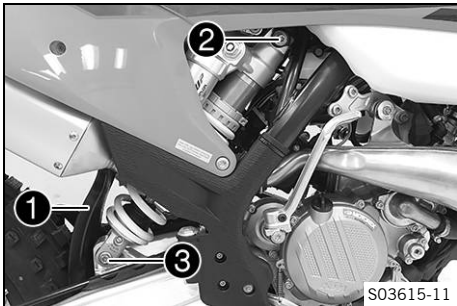

Main work

- Push splash protector **1** to the side and position the shock absorber. Mount and tighten screw **2**.

Guideline

Screw, top shock absorber	M12	80 Nm (59 lbf ft) Loctite®2701™
---------------------------	-----	---

- Mount and tighten screw **3**.

Guideline

Screw, bottom shock absorber	M12	80 Nm (59 lbf ft) Loctite®2701™
------------------------------	-----	---

i Info

The heim joint for the shock absorber on the link fork is Teflon coated. It must not be lubricated with grease, nor with any other lubricants. Lubricants dissolve the Teflon coating, thereby drastically reducing the service life.

Finishing work

- Remove the motorcycle from the lift stand. (📖 p. 17)

3.9 Installing the fork legs

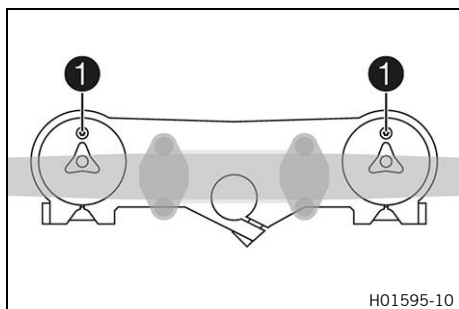

Main work

- Position the fork legs.
- ✓ Bleeder screws ① are positioned toward the front.



Info

The rebound damping is located in right fork leg **REB** (red adjuster). The compression damping is located in left fork leg **COMP** (white adjuster). Grooves are milled into the side of the upper end of the fork legs. The second milled groove (from the top) must be flush with the upper edge of the upper triple clamp.

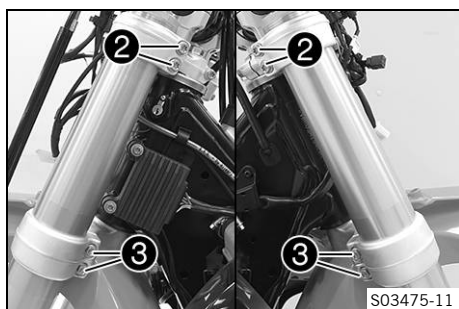

- Tighten screws ②.

Guideline

Screw, top triple clamp	M8	20 Nm (14.8 lbf ft)
-------------------------	----	---------------------

- Tighten screws ③.

Guideline

Screw, bottom triple clamp	M8	15 Nm (11.1 lbf ft)
----------------------------	----	---------------------

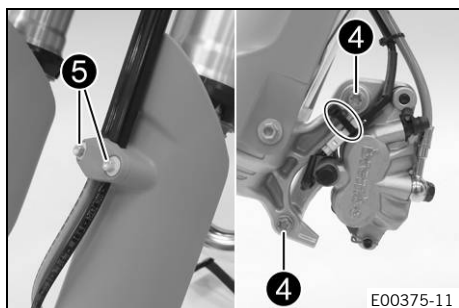

- Position the brake caliper, and mount and tighten screws ④.

Guideline

Screw, front brake caliper	M8	25 Nm (18.4 lbf ft) Loctite®243™
----------------------------	----	--

- Mount the cable ties.
- Position the brake line, the wiring harness, and the clamp. Mount and tighten screws ⑤.

Finishing work

- Install the front wheel. (📖 p. 23)
- Install the headlight mask with the headlight. (📖 p. 33)
- Check the headlight setting. (📖 p. 34)



3.10 Installing the front wheel



Warning

Danger of accidents Oil or grease on the brake discs reduces the braking effect.

- Always keep the brake discs free of oil and grease.
- Clean the brake discs with brake cleaner when necessary.

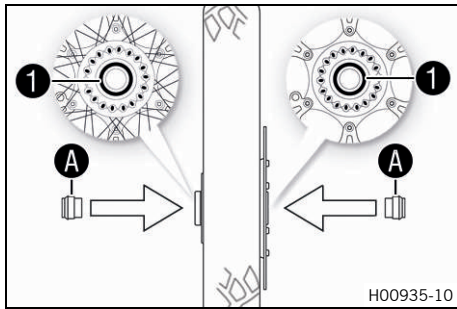

- Check the wheel bearing for damage and wear.
 - » If the wheel bearing is damaged or worn:
 - Change front wheel bearing.
- Clean and grease shaft seal rings **1** and contact surface **A** of the spacers.

Long-life grease (📖 p. 44)

- Insert the spacers.
- Clean and grease the wheel spindle.

Long-life grease (📖 p. 44)

- Position the front wheel and insert the wheel spindle.
 - ✓ The brake linings are correctly positioned.

- Mount and tighten screw **2**.

Guideline

Screw, front wheel spindle	M20x1.5	35 Nm (25.8 lbf ft)
----------------------------	---------	---------------------

- Operate the hand brake lever several times until the brake linings are seated correctly against the brake disc.
- Remove the motorcycle from the lift stand. (📖 p. 17)
- Operate the front brake and compress the fork a few times firmly.

✓ The fork legs straighten.

- Tighten screws **3**.

Guideline

Screw, fork stub	M8	15 Nm (11.1 lbf ft)
------------------	----	---------------------

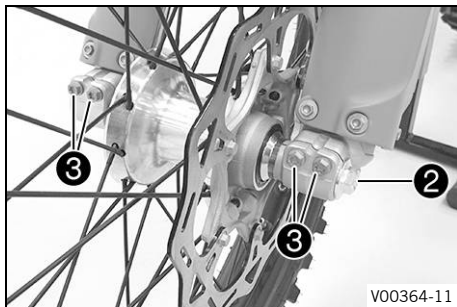

3.11 Removing the 12-V battery



Note

Environmental hazard 12 V batteries contain environmentally hazardous materials.

- Do not dispose of 12 V batteries as household waste.
- Dispose of 12 V batteries at a collection point for used batteries.



Note

Environmental hazard Hazardous substances cause environmental damage.

- Dispose of oils, grease, filters, fuel, cleaning agents, brake fluid, etc., correctly and in compliance with the applicable regulations.

Preparatory work (150 EXC TPI EU)

- Press and hold the switch-off button ☒ while the engine is idling until the engine stops.

(150 XC-W TPI US)

- Press and hold the switch-off button ☒ while the engine is idling until the engine stops.
- Remove the seat. (📖 p. 17)

Main work

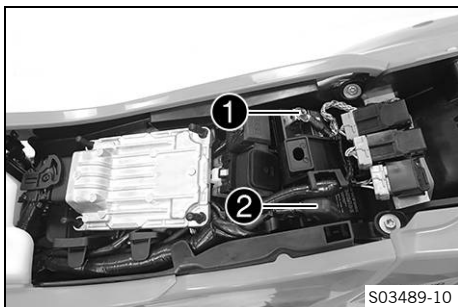

Warning

Risk of injury 12 V batteries contain harmful substances.

- Keep 12 V batteries out of the reach of children.
- Keep sparks and open flames away from 12 V batteries.
- Only charge 12 V batteries in well-ventilated rooms.
- Maintain a minimum clearance from inflammable materials when charging 12 V batteries.
Minimum clearance 1 m (3 ft)
- Do not charge deeply discharged 12 V batteries if the charge is already below the minimum voltage.
Minimum voltage before the start of the charge 9 V
- Dispose of 12 V batteries with less than the minimum voltage correctly.

- Disconnect negative cable ① from the 12-V battery.
- Pull back positive terminal cover ② and disconnect the positive cable from the 12-V battery.
- Pull EFI control unit ③ upward off rubber lugs ④ and hang to the side.

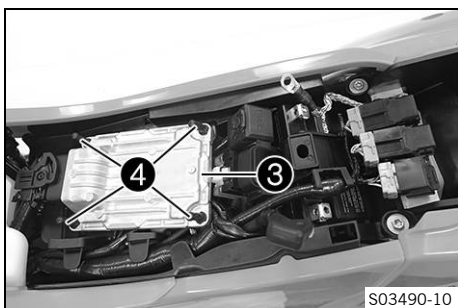

- Pull off starter relay ⑤ and fuse box ⑥ from the battery compartment and hang to the side.

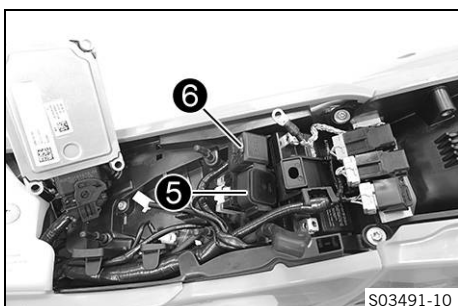

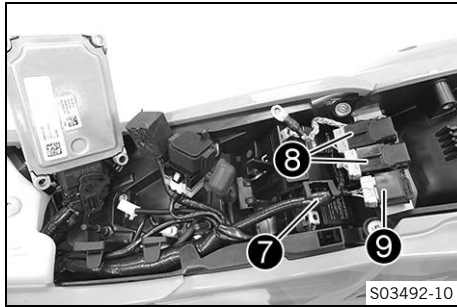

- Detach wiring harness ⑦, disconnect relays ⑧ and plug ⑨, and hang to the side.

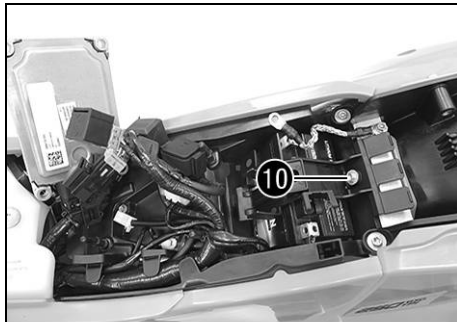

- Remove screw ⑩ and detach the battery compartment.
- Lift out the 12-V battery.



3.12 Charging the 12-V battery



Warning

Risk of injury 12 V batteries contain harmful substances.

- Keep 12 V batteries out of the reach of children.
- Keep sparks and open flames away from 12 V batteries.
- Only charge 12 V batteries in well-ventilated rooms.
- Maintain a minimum clearance from inflammable materials when charging 12 V batteries.
Minimum clearance 1 m (3 ft)
- Do not charge deeply discharged 12 V batteries if the charge is already below the minimum voltage.
Minimum voltage before the start of the charge 9 V
- Dispose of 12 V batteries with less than the minimum voltage correctly.



Note

Environmental hazard 12 V batteries contain environmentally hazardous materials.

- Do not dispose of 12 V batteries as household waste.
- Dispose of 12 V batteries at a collection point for used batteries.



Note

Environmental hazard Hazardous substances cause environmental damage.

- Dispose of oils, grease, filters, fuel, cleaning agents, brake fluid, etc., correctly and in compliance with the applicable regulations.



Info

Even if there is no load on the 12-V battery, it discharges each day. The charging level and the method of charging are very important for the service life of the 12-V battery. Rapid recharging with a high charging current shortens the service life of the battery. If the charging current, charging voltage, or charging time is exceeded, the 12-V battery will be destroyed. If the 12-V battery is depleted by repeated starting, the 12-V battery must be charged immediately. If the 12-V battery is left in a discharged state for an extended period, it will become deeply discharged and suffer a loss of capacity, destroying the battery. The 12-V battery is maintenance-free.

Preparatory work

(150 EXC TPI EU)

- Press and hold the switch-off button ☒ while the engine is idling until the engine stops.

(150 XC-W TPI US)

- Press and hold the switch-off button ☒ while the engine is idling until the engine stops.
- Remove the seat. (📖 p. 17)
- Disconnect the negative cable of the 12-V battery. (📖 p. 29)

Main work

- Connect a battery charger to the 12-V battery. Adjust the battery charger.

EU battery charger **XCharge-professional** (00029095050)

Alternative 1

US battery charger **XCharge-professional** (00029095051)

Alternative 2

UK battery charger **XCharge-professional** (00029095052)

Alternative 3

CH battery charger **XCharge-professional** (00029095053)

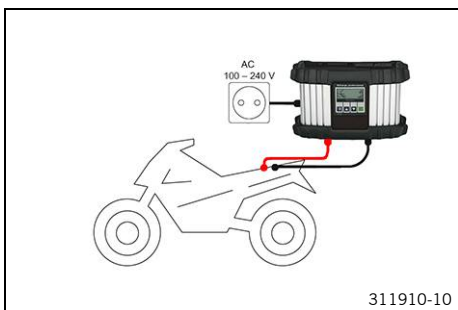

Info

Follow the instructions of the charger and the manual.

- Disconnect the battery charger after charging the 12-V battery.

Guideline

The charging current, charging voltage, and charging time must not be exceeded.	
Recharge the 12-V battery regularly when the motorcycle is not being used	3 months

Finishing work

- Connect the negative cable of the 12-V battery. (📖 p. 30)

- Mount the seat. (📖 p. 18)

3.13 Installing the 12-V battery



Main work

- Insert the 12-V battery into the battery compartment with the terminals facing forward and secure with holding bracket ①.

12-V battery (HJTZ5S-FP)

- Mount and tighten screw ②.

Guideline

Remaining screws, chassis	M6	10 Nm (7.4 lbf ft)
---------------------------	----	--------------------

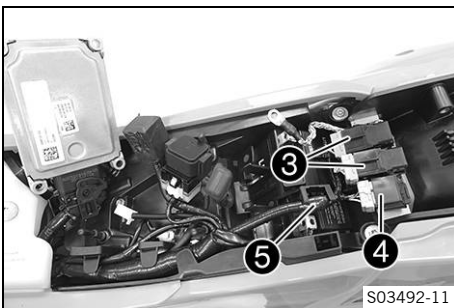
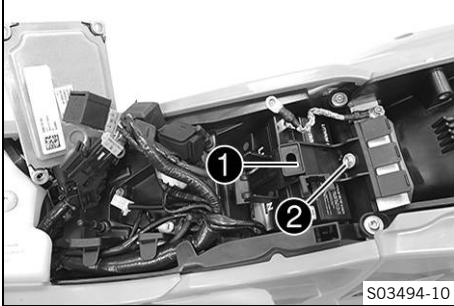

- Place relays ③ and connector ④ on the battery compartment and attach the wiring harness ⑤.

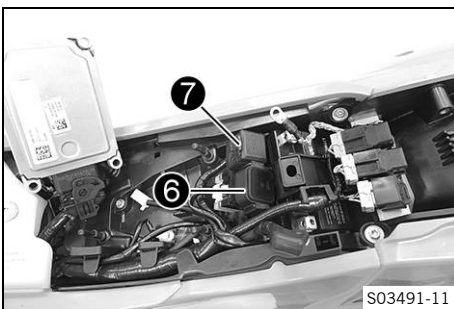

- Attach starter relay ⑥ and fuse box ⑦ to the battery compartment.

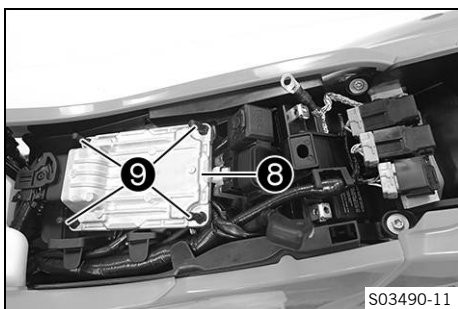

- Secure EFI control unit **8** with the rubber lugs **9**.

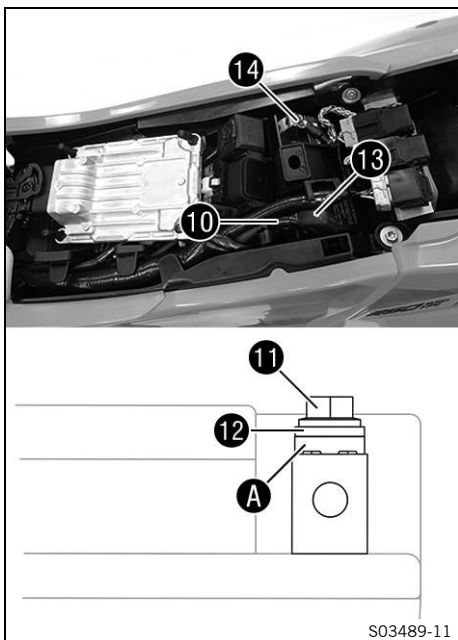

- Connect positive cable **10** to the 12-V battery.

Guideline

Screw, battery terminal	M5	2.5 Nm (1.84 lbf ft)
-------------------------	----	-------------------------

i Info

Contact disk **A** must be mounted under screw **11** and cable lug **12** with the claws toward the battery terminal.

- Slide positive terminal cover **13** over the positive terminal.
- Connect negative cable **14** to the 12-V battery.

Guideline

Screw, battery terminal	M5	2.5 Nm (1.84 lbf ft)
-------------------------	----	-------------------------

Finishing work

- Mount the seat. (📖 p. 18)

3.14 Disconnecting the negative cable of the 12-V battery

Preparatory work
(150 EXC TPI EU)

- Press and hold the switch-off button  while the engine is idling until the engine stops.

(150 XC-W TPI US)

- Press and hold the switch-off button  while the engine is idling until the engine stops.
- Remove the seat. (📖 p. 17)

Main work

- Disconnect negative cable **1** of the 12-V battery.

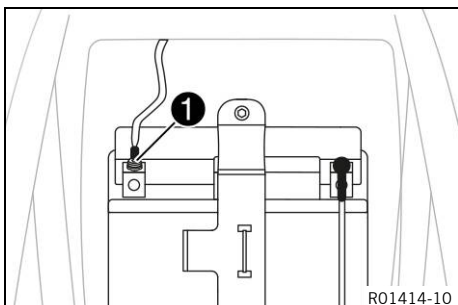

3.15 Connecting the negative cable of the 12-V battery

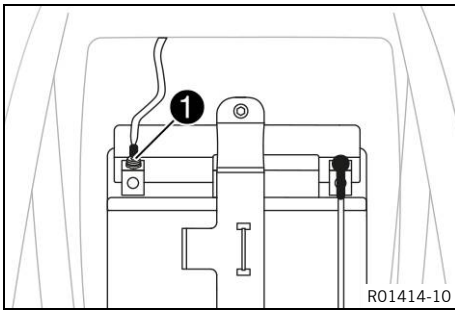

Main work

- Connect negative cable **1** of the 12-V battery.

Guideline

Screw, battery terminal	M5	2.5 Nm (1.84 lbf ft)
-------------------------	----	-------------------------

Finishing work

- Mount the seat. (📖 p. 18)

3.16 Removing the air filter box cover

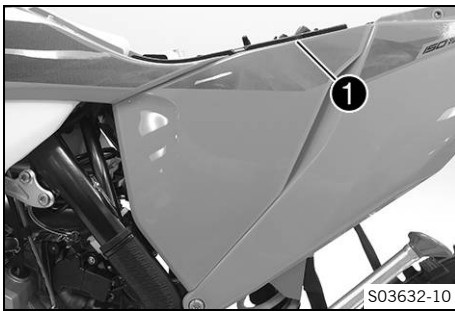

Preparatory work

- Remove the seat. (📖 p. 17)

Condition

The air filter box cover is secured.

- Remove screw **1**.

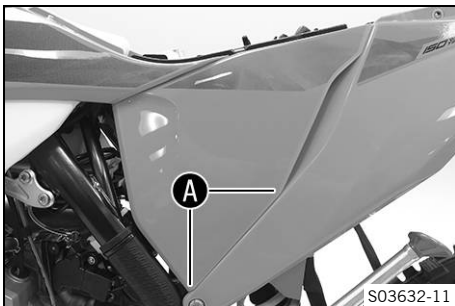

- Pull off the air filter box cover in area **A** laterally and take it off at the front.

3.17 Installing the air filter box cover

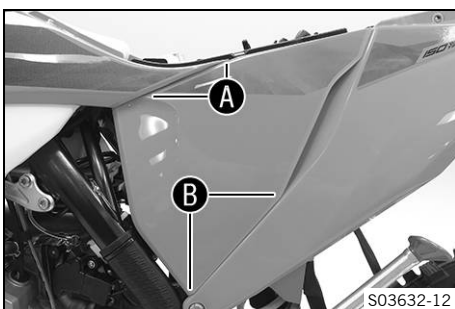

Main work

- Insert the air filter box cover in area **A** and clip it into area **B**.

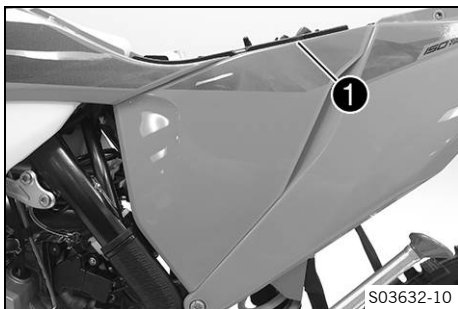

Condition

The air filter box cover is secured.

- Mount and tighten screw 1.

Guideline

Screw, air filter box cover	EJOT PT® K60x20-Z	3 Nm (2.2 lbf ft)
-----------------------------	-----------------------------	-------------------

Finishing work

- Mount the seat. (📖 p. 18)

3.18 Removing the rear left side cover



- Remove screw 1 and take off the fairing part to the front.

3.19 Installing the rear left side cover

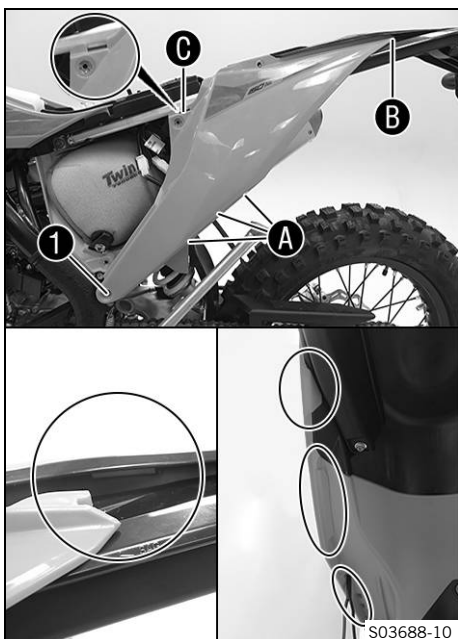

- Position side cover and hook it in in areas A, B and C.
- Mount and tighten screw 1.

Guideline

Screw, sub-frame bottom	M8	30 Nm (22.1 lbf ft) Loctite®2701™
-------------------------	----	---

3.20 Installing front fender

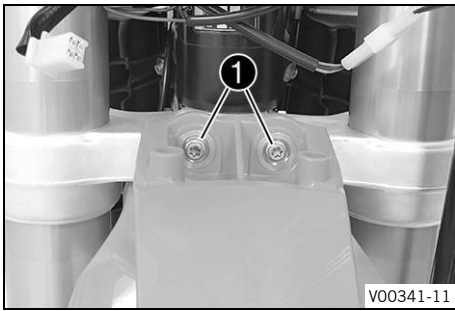

Main work

- Position front fender. Mount and tighten screws **1**.

Guideline

Remaining screws, chassis	M6	10 Nm (7.4 lbf ft)
---------------------------	----	--------------------

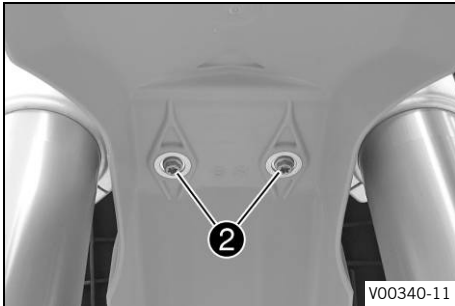

- Mount and tighten screws **2**.

Guideline

Remaining screws, chassis	M6	10 Nm (7.4 lbf ft)
---------------------------	----	--------------------

Finishing work

- Install the headlight mask with the headlight. (📖 p. 33)
- Check the headlight setting. (📖 p. 34)

3.21 Removing the headlight mask with the headlight

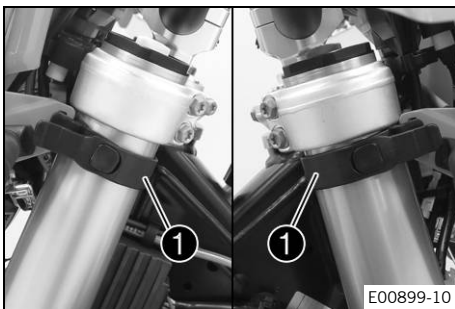

- Detach the brake line and wiring harness from the headlight mask.
- Loosen rubber strap **1**. Slide the headlight mask up and swing it forward.

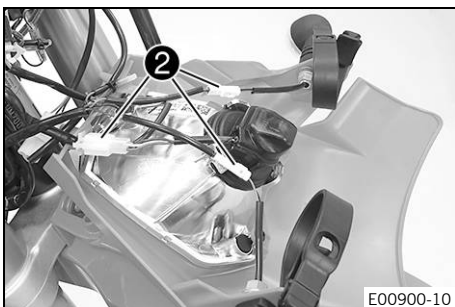

(150 EXC TPI EU)

- Detach plug-in connectors **2** and take off the headlight mask with the headlight.

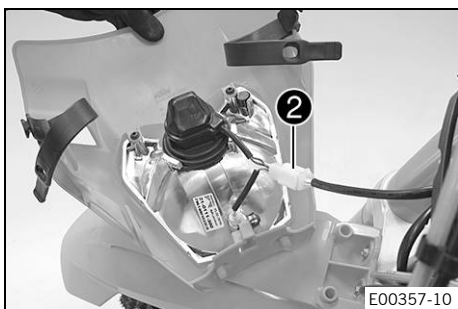

(150 XC-W TPI US)

- Disconnect plug-in connector ② and take off the headlight mask together with the headlight.

3.22 Installing the headlight mask with the headlight

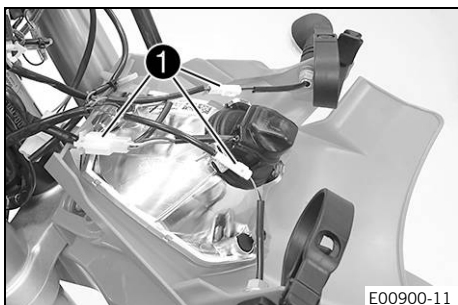

Main work

(150 EXC TPI EU)

- Join plug-in connectors ①.

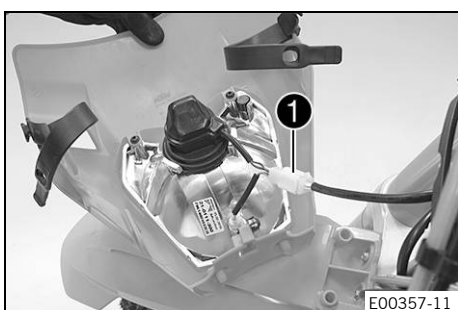

(150 XC-W TPI US)

- Join plug-in connector ①.

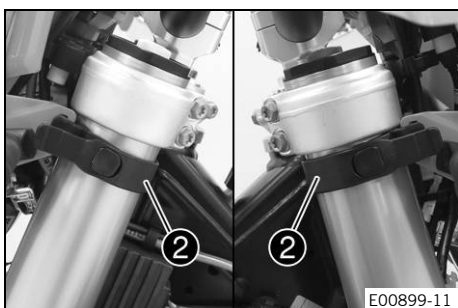

- Position the headlight mask and secure it with rubber straps ②.
- ✓ The holding lugs engage in the fender.
- Position the brake line and wiring harness in the brake line guide.

Finishing work

- Check the headlight setting. (📖 p. 34)

3.23 Checking the headlight setting

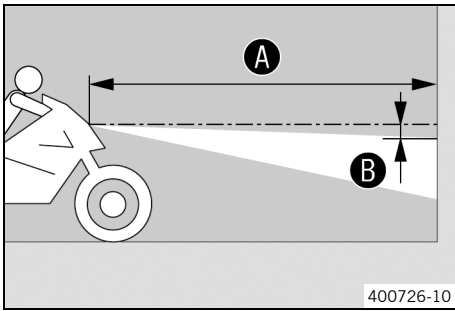

- Park the vehicle on a horizontal surface in front of a light-colored wall and make a mark at the height of the center of the low beam headlight.
- Make another mark at a distance **B** under the first marking.
Guideline

Distance B	5 cm (2 in)
-------------------	-------------

- Position the vehicle vertically at a distance **A** away from the wall.
Guideline

Distance A	5 m (16 ft)
-------------------	-------------

- The rider now sits down on the motorcycle.
- Switch on the low beam.
- Check the headlight setting.

The boundary between light and dark must be exactly on the lower mark for a motorcycle with rider.
--

- » If the boundary between light and dark does not meet specifications:
 - Adjust the headlight range. (📖 p. 34)

3.24 Adjusting the headlight range

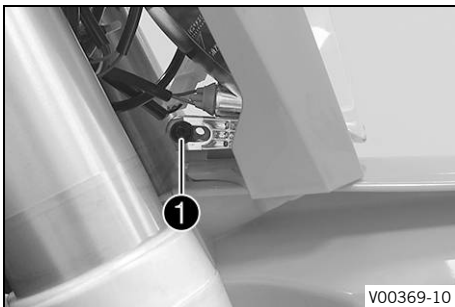

Preparatory work

- Check the headlight setting. (📖 p. 34)

Main work

- Loosen screw **1**.
- Adjust the headlight range by pivoting the headlight.

Guideline

The boundary between light and dark must be exactly on the lower mark for a motorcycle with rider (instructions on how to apply the mark: Checking the headlight setting).
--

Info

i If you have a payload, you may have to correct the headlight range.

- Tighten screw **1**.

3.25 Installing the engine guard

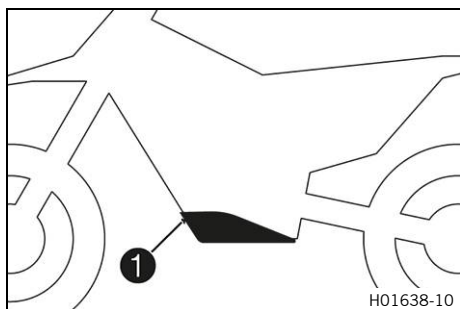

- Attach the engine guard on the frame at the rear and swing up at the front.
- Mount and tighten screws ①.

Guideline

Remaining screws, chassis	M6	10 Nm (7.4 lbf ft)
---------------------------	----	--------------------

3.26 Opening 2-stroke oil tank cap

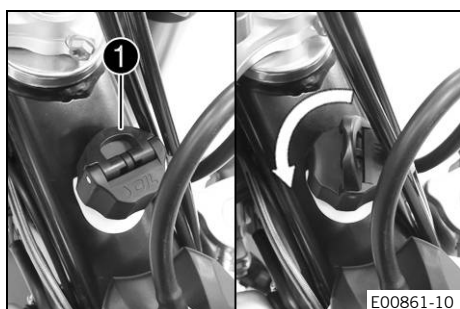

- Fold loop ① upward.
- Turn the 2-stroke oil tank cap counterclockwise and pull it up.

3.27 Closing 2-stroke oil tank cap

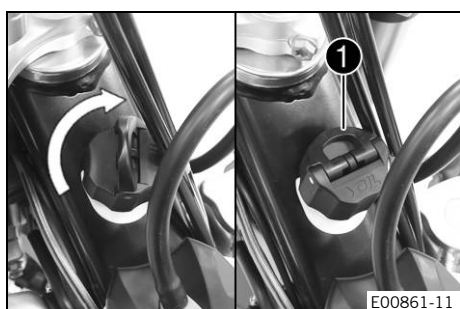

- Put the 2-stroke oil tank cap on and turn it clockwise.
- Fold loop ① down.
- ✓ The 2-stroke oil tank cap engages.

3.28 Adding 2-stroke oil



Warning

Engine failure The engine will not be lubricated unless there is 2-stroke oil in the oil tank.

If the oil level warning light lights up, the 2-stroke oil is sufficient for the remaining tank of fuel.

- As soon as the oil level warning light lights up, ride for no longer than until the remaining fuel in the tank is depleted.
- At the next opportunity add 2-stroke oil before you refuel.
- Time the oil pump if the 2-stroke oil hose has been removed or the 2-stroke oil tank has been fully depleted in error.

- Open 2-stroke oil tank cap. (📖 p. 35)

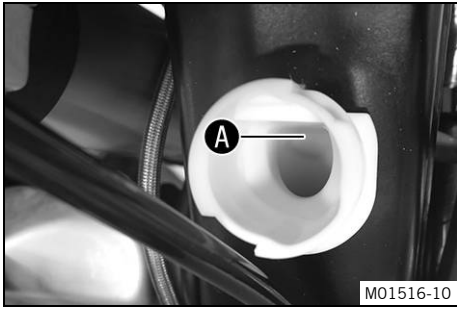

- Fill the 2-stroke oil tank up to the lower edge **A** of the filler neck.

2-stroke oil tank content approx.	0.6 l (0.6 qt.)	Engine oil, 2-stroke (📖 p. 43)
-----------------------------------	-----------------	--------------------------------

- Close 2-stroke oil tank cap. (📖 p. 35)

3.29 Opening the fuel tank filler cap



Danger

Fire hazard Fuel is highly flammable.

The fuel in the fuel tank expands when warm and can escape if overfilled.

- Do not refuel the vehicle in the vicinity of open flames or lit cigarettes.
- Switch off the engine for refueling.
- Make sure that no fuel is spilled; particularly not on hot parts of the vehicle.
- If any fuel is spilled, wipe it off immediately.
- Observe the specifications for refueling.



Warning

Danger of poisoning Fuel is poisonous and a health hazard.

- Avoid skin, eye and clothing contact with fuel.
- Immediately consult a doctor if you swallow fuel.
- Do not inhale fuel vapors.
- In case of skin contact, rinse the affected area with plenty of water.
- Rinse the eyes thoroughly with water, and consult a doctor in case of fuel contact with the eyes.
- Change your clothing in case of fuel spills on them.
- Keep fuels correctly in a suitable canister, and out of the reach of children.



Note

Environmental hazard Improper handling of fuel is a danger to the environment.

- Do not allow fuel to enter the groundwater, the soil, or the sewage system.

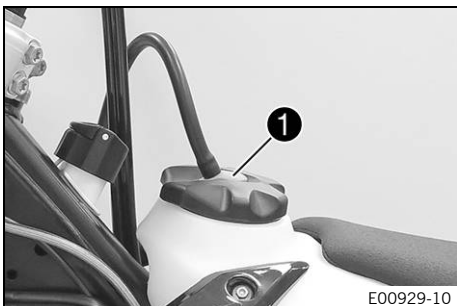

- Press release button **1**, turn the fuel tank filler cap counter-clockwise, and lift it off.

3.30 Closing the fuel tank filler cap

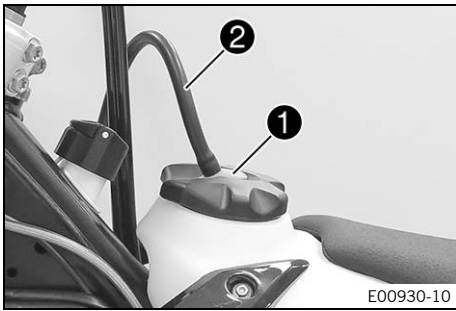

- Mount the fuel tank filler cap and turn it clockwise until release button ① engages.



Info

Route fuel tank breather hose ② without kinks.

3.31 Refueling



Danger

Fire hazard Fuel is highly flammable.

The fuel in the fuel tank expands when warm and can escape if overfilled.

- Do not refuel the vehicle in the vicinity of open flames or lit cigarettes.
- Switch off the engine for refueling.
- Make sure that no fuel is spilled; particularly not on hot parts of the vehicle.
- If any fuel is spilled, wipe it off immediately.
- Observe the specifications for refueling.



Warning

Danger of poisoning Fuel is poisonous and a health hazard.

- Avoid skin, eye and clothing contact with fuel.
- Immediately consult a doctor if you swallow fuel.
- Do not inhale fuel vapors.
- In case of skin contact, rinse the affected area with plenty of water.
- Rinse the eyes thoroughly with water, and consult a doctor in case of fuel contact with the eyes.
- Change your clothing in case of fuel spills on them.

Note

Material damage Inadequate fuel quality causes the fuel filter to quickly become clogged.

In some countries and regions, the available fuel quality and cleanliness may not be sufficient. This will result in problems with the fuel system.

- Refuel only with clean fuel that meets the specified standards.



Note

Environmental hazard Improper handling of fuel is a danger to the environment.

- Do not allow fuel to enter the groundwater, the soil, or the sewage system.

- Open the fuel tank filler cap. (📖 p. 36)

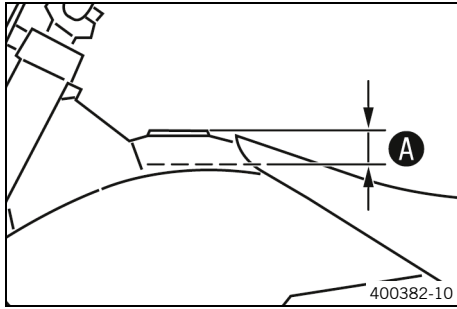

- Fill the fuel tank with fuel up to level **A**.

Guideline

Level A	35 mm (1.38 in)	
Total fuel tank capacity, approx.	8.5 l (2.25 US gal)	Super unleaded (ROZ 95/RON 95/PON 91) (📖 p. 43)



Info

Do not refuel using pre-mixed fuel.

- Close the fuel tank filler cap. (📖 p. 37)

3.32 Setting the kilometers or miles



Info

If you change the unit, the value **ODO** is retained and converted accordingly. The values **TR1**, **TR2**, **A1**, **A2** and **S1** are cleared when the unit of measure is changed.

Condition

The motorcycle is stationary.

- Repeatedly press the button **+** briefly until **H** appears at the bottom right of the display.
- Press the button **+** for 2–3 seconds.
 - ✓ The Setup menu is displayed and the active functions are shown.
- Repeatedly press the button **+** briefly until **Km/h/Mph** flashes.

Adjusting the Km/h

- Press the button **+**.

Adjusting the Mph

- Press the button **-**.
- Wait 3 - 5 seconds.

✓ The settings are stored.



Info

If no button is pressed for 10–12 seconds, or if an impulse comes from the wheel speed sensor, the settings are automatically saved and the setup menu is closed.

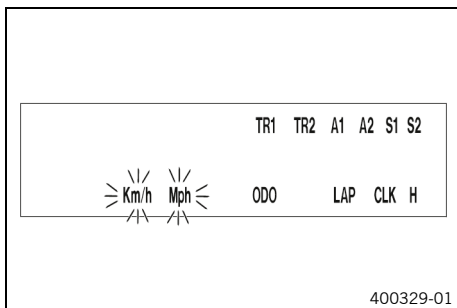

3.33 Adjusting combination instrument function

i Info

When the vehicle is delivered, only the **SPEED/H** and **SPEED/ODO** display modes are activated.

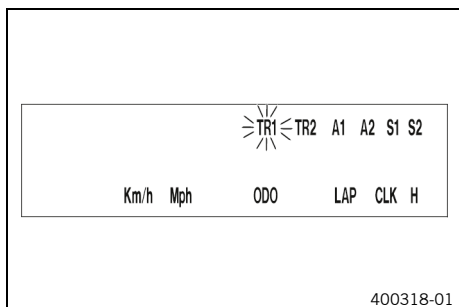

Condition

The motorcycle is stationary.

- Repeatedly press the button briefly until **H** appears at the bottom right of the display.
- Press the button for 2–3 seconds.
 - ✓ The Setup menu is displayed and the active functions are shown.

i Info

If no button is pressed for 10–12 seconds, the settings are automatically saved. If no button is pressed for 20 seconds, or if an impulse comes from the wheel speed sensor, the settings are automatically saved and the setup menu is closed.

- Repeatedly press the button briefly until the desired function flashes.
 - ✓ The selected function flashes.

Activating the function

- Press the button .
 - ✓ The symbol continues to appear in the display and the next function appears.

Deactivating a function

- Press the button .
 - ✓ The symbol disappears in the display and the next function appears.



3.34 Setting the clock



Condition

The motorcycle is stationary.

- Repeatedly press the button briefly until **CLK** appears at the bottom right of the display.
- Press the button for 2–3 seconds.
 - ✓ The hour display flashes.
- Adjust hour display with the button and/or button .
- Wait 3 - 5 seconds.
 - ✓ The next segment of the display flashes and can be set.
- You can set the following segments in the same way as the hours by pressing the button and the button .

i **Info**

The seconds can only be set to zero.
If no button is pressed for 15–20 seconds, or if an impulse comes from the wheel speed sensor, the settings are automatically saved and the setup menu is closed.



4.1 Chassis tightening torques

Remaining screws, chassis	EJOT PT® K60x25-Z	2 Nm (1.5 lbf ft)
Screw, intake air temperature sensor	EJOTDELTA PT® 45x12-Z	0.7 Nm (0.52 lbf ft)
Screw, oil fill level sensor	G 3/4 "	7 Nm (5.2 lbf ft)
Screw, oil pump holder on oil tank	EJOTDELTA PT 45x12-Z	0.7 Nm (0.52 lbf ft)
Screw, pressure regulator	EJOT PT® K60x25-Z	2.3 Nm (1.7 lbf ft)
Screw, seat fixing	EJOTEJOFORM PT® K60x23/18	2.5 Nm (1.84 lbf ft)
Screw, emergency OFF switch (150 EXC TPI EU)	M4	0.4 Nm (0.3 lbf ft)
Screw, fixed grip	M4	5 Nm (3.7 lbf ft) Loctite®243™
Spoke nipple, front wheel	M4.5	5 Nm (3.7 lbf ft)
Spoke nipple, rear wheel	M4.5	5 Nm (3.7 lbf ft)
Remaining nuts, chassis	M5	5 Nm (3.7 lbf ft)
Remaining screws, chassis	M5	5 Nm (3.7 lbf ft)
Screw, battery terminal	M5	2.5 Nm (1.84 lbf ft)
Screw, ground wire in tail section	M5	5 Nm (3.7 lbf ft)
Screw, light switch (150 EXC TPI EU)	M5	1 Nm (0.7 lbf ft)
Screw, shock absorber adjusting ring	M5	5 Nm (3.7 lbf ft)
Screw, turn signal switch (150 EXC TPI EU)	M5	1 Nm (0.7 lbf ft)
Nut, cable on starter motor	M6	4 Nm (3 lbf ft)
Remaining nuts, chassis	M6	10 Nm (7.4 lbf ft)
Remaining screws, chassis	M6	10 Nm (7.4 lbf ft)
Screw, ball joint of push rod on foot brake cylinder	M6	10 Nm (7.4 lbf ft) Loctite®243™
Screw, chain sliding guard	M6	6 Nm (4.4 lbf ft) Loctite®243™
Screw, front brake disc	M6	14 Nm (10.3 lbf ft) Loctite®243™
Screw, manifold on silent block	M6	6 Nm (4.4 lbf ft)
Screw, rear brake disc	M6	14 Nm (10.3 lbf ft) Loctite®243™
Screw, silent block on frame	M6	6 Nm (4.4 lbf ft)
Screw, throttle grip	M6	5 Nm (3.7 lbf ft)
Fuel connection on fuel pump	M8	10 Nm (7.4 lbf ft)
Nut, foot brake lever	M8	15 Nm (11.1 lbf ft)
Nut, foot brake lever stop	M8	20 Nm (14.8 lbf ft)
Nut, pull switch (150 XC-W TPI US)	M8	0.4 Nm (0.3 lbf ft)
Nut, rear sprocket screw	M8	35 Nm (25.8 lbf ft) Loctite®2701™
Nut, rim lock	M8	12 Nm (8.9 lbf ft)
Remaining nuts, chassis	M8	25 Nm (18.4 lbf ft)

4 TECHNICAL DATA

Remaining screws, chassis	M8	25 Nm (18.4 lbf ft)
Screw, bottom triple clamp	M8	15 Nm (11.1 lbf ft)
Screw, chain sliding piece	M8	15 Nm (11.1 lbf ft)
Screw, engine brace	M8x15	25 Nm (18.4 lbf ft) Loctite®2701™
Screw, fork stub	M8	15 Nm (11.1 lbf ft)
Screw, front brake caliper	M8	25 Nm (18.4 lbf ft) Loctite®243™
Screw, handlebar clamp	M8	20 Nm (14.8 lbf ft)
Screw, side stand attachment	M8	33 Nm (24.3 lbf ft) Loctite®2701™
Screw, subframe bottom	M8	30 Nm (22.1 lbf ft) Loctite®2701™
Screw, top steering stem	M8	20 Nm (14.8 lbf ft)
Screw, top triple clamp	M8	20 Nm (14.8 lbf ft)
Engine bracket screw	M10	60 Nm (44.3 lbf ft)
Remaining nuts, chassis	M10	45 Nm (33.2 lbf ft)
Remaining screws, chassis	M10	45 Nm (33.2 lbf ft)
Screw, handlebar support	M10	40 Nm (29.5 lbf ft) Loctite®243™
Nut, fuel pump	M12	15 Nm (11.1 lbf ft)
Screw, bottom shock absorber	M12	80 Nm (59 lbf ft) Loctite®2701™
Screw, top shock absorber	M12	80 Nm (59 lbf ft) Loctite®2701™
Nut, fork pivot	M16x1.5	100 Nm (73.8 lbf ft)
Nut, rear wheel spindle	M20x1.5	80 Nm (59 lbf ft)
Screw, front wheel spindle	M20x1.5	35 Nm (25.8 lbf ft)
Screw, top steering head	M20x1.5	12 Nm (8.9 lbf ft)
Screw-in fitting, cooling system	M24x1.5	15 Nm (11.1 lbf ft) Loctite®243™

Engine oil, 2-stroke**Standard/classification**

- JASO FD (📖 p. 45)

Guideline

- Only use high grade 2-stroke engine oil of a reputable brand.

Fully synthetic

Recommended supplier**MOTOREX®**

- **Cross Power 2T**

Super unleaded (ROZ 95/RON 95/PON 91)**Standard/classification**

- DIN EN 228 (ROZ 95/RON 95/PON 91)

Guideline

- Only use unleaded super fuel that matches or is equivalent to the specified fuel grade.
- Fuel with an ethanol content of up to 10 % (E10 fuel) is safe to use.

**Info**

Do **not** use fuel containing methanol (e. g. M15, M85, M100) or more than 10 % ethanol (e. g. E15, E25, E85, E100).

Long-life grease

Recommended supplier

MOTOREX®

– Bike Grease 2000

JASO FD

JASO FD is a classification for a 2-stroke engine oil that was specifically developed for the extreme demands of racing. Thanks to first-rate synthetic esters and specially designed additives, superb combustion is achieved even under extreme operating conditions.



3214036en

07/2019

