

Freeride 250 F

Art. no. 3214152en



KTM

Perform the work described in these setup instructions before the vehicle is delivered to the customer.

Read the setup instructions in their entirety before beginning work.

These setup instructions were written to correspond to the latest state of this series. We reserve the right to make changes in the interest of technical advancement without at the same time updating this manual. We shall not provide a description of general workshop methods. Likewise, safety rules that apply in a workshop are not specified here. It is assumed that the work will be performed by a fully trained mechanic.

All specifications contained herein are non-binding. KTM Sportmotorcycle GmbH specifically reserves the right to modify or delete technical specifications, prices, colors, forms, materials, services, designs, equipment, etc., without prior notice and without specifying reasons, to adapt these to local conditions, as well as to stop production of a particular model without prior notice. KTM accepts no liability for delivery options, deviations from figures and descriptions, misprints, and other errors. The models portrayed partly contain special equipment that does not belong to the regular scope of supply.

© 2019 KTM Sportmotorcycle GmbH, Mattighofen Austria

All rights reserved

Reproduction, even in part, as well as copying of all kinds, is permitted only with the express written permission of the copyright owner.



ISO 9001(12 100 6061)

KTM applies quality assurance processes that lead to the highest possible product quality as defined in the ISO 9001 international quality management standard.

Issued by: TÜV Management Service

REG.NO. 12 100 6061

KTM Sportmotorcycle GmbH

Stallhofnerstraße 3

5230 Mattighofen, Austria

This document is valid for the following models:

Freeride 250 F EU (F8103T4)



1 MEANS OF REPRESENTATION

1.1 Symbols used

The meaning of specific symbols is described below.



Indicates an expected reaction (e.g. of a work step or a function).



Indicates an unexpected reaction (e.g. of a work step or a function).



Indicates a page reference (more information is provided on the specified page).



Indicates information with more details or tips.



Indicates the result of a testing step.



Indicates a voltage measurement.



Indicates a current measurement.



Indicates a resistance measurement.



Indicates the end of an activity including potential rework.

1.2 Formats used

The typographical formats used in this document are explained below.

Proprietary name

Indicates a proprietary name.

Name®

Indicates a protected name.

Brand™

Indicates a brand available on the open market.

Underlined terms

Refer to technical details of the vehicle or indicate technical terms, which are explained in the glossary.

2.1 Transport mode

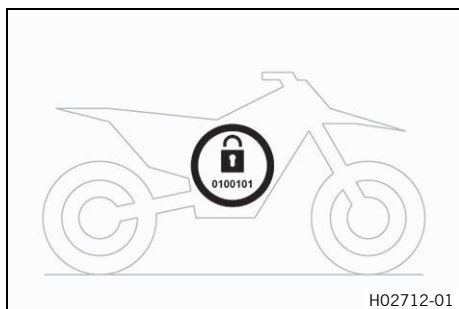

This vehicle was blocked for transport in the software. To operate the vehicle, the vehicle electronics must be enabled. This process is conducted during initial setup in KTM Dealer.net. Enabling ensures that the initial setup in KTM Dealer.net is documented.

Enabling can be performed either temporarily, e.g. for a test ride, or permanently for vehicle handover.



Info

Make sure that the vehicle is permanently enabled before handing it over to the customer.

2.2 Diagnostics connector

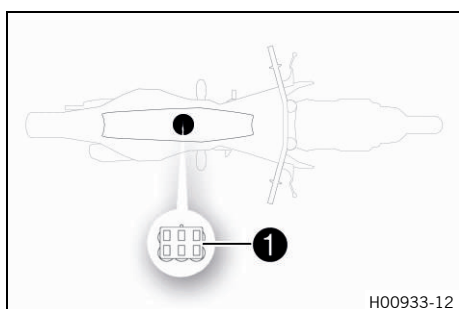

Diagnostics connector **1** is located under the seat.

2.3 Unpacking and setting up the vehicle

Condition

Packaging V2

- Unpack and set up the V2 vehicle. (📖 p. 5)
- Remove V2 headlight mask. (📖 p. 5)

Condition

Packaging V12

- Unpack and set up the V12 vehicle. (📖 p. 6)
- Install V12 fork legs. (📖 p. 7)
- Install V12 shock absorber. (📖 p. 7)
- Install C12 combination instrument. (📖 p. 8)
- Stick on the reflector. (📖 p. 8)
- Install handlebars. (📖 p. 8)
- Install the handlebar cushion. (📖 p. 9)
- Install left side controls. (📖 p. 10)
- Install right side controls. (📖 p. 12)
- Install left and right rear mirrors. (📖 p. 12)
- Install left and right hand guards. (📖 p. 13)
- Install front fender. (📖 p. 14)
- Install the front wheel. (📖 p. 14)
- Install the front and rear turn signals. (📖 p. 15)
- Install the license plate lamp. (📖 p. 15)
- Install the reflector. (📖 p. 16)
- Route the front turn signal cable. (📖 p. 16)
- Route the rear turn signal cable. (📖 p. 16)

- Install the license plate holder extension. (📖 p. 19)
- Remove the motorcycle from the lift stand. (📖 p. 20)
- Install the engine guard. (📖 p. 20)
- Install the footrests. (📖 p. 20)
- Charge the 12 V battery. (📖 p. 22)
- Install the headlight mask with the headlight. (📖 p. 24)
- Check the headlight setting. (📖 p. 24)
- Set the combination instrument. (📖 p. 25)
- Set the kilometers or miles. (📖 p. 26)
- Set the clock. (📖 p. 26)
- Refuel. (📖 p. 27)
- Unpack and mount the **KTM PowerParts** included in the delivery (optional).



Info

Read the accompanying **KTM PowerParts** fitting instructions.

-
- Remove the remaining films, padding, the corrugated cardboard, and the other packaging material.
 - Attach the stickers included in the scope of supply (optional).
 - Prepare the vehicle according to the specifications in **KTM Dealer.net** for handover to the customer.



Info

Transport mode must be deactivated to be able to start the motorcycle.



3.1 Unpacking and setting up the V2 vehicle

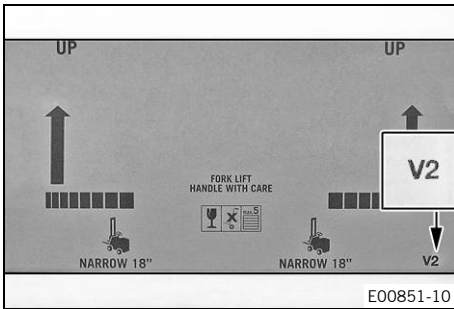

- Remove the box and the plastic packaging.

i Info
An assistant prevents the motorcycle from falling over. To avoid damaging the motorcycle during the setup, leave the protective film on the vehicle until you have finished.

- Remove and unpack the separate enclosure and components. Check that the scope of supply is complete using the enclosed packing list.

i Info
The procedure in the event of missing parts is described in the customer service manual.

- Have a lift stand available.

Lift stand (78929955100)

- Carefully loosen and remove the tension belt of the footrest mount.

i Info
An assistant prevents the motorcycle from falling over.

- Together with an assistant, take the vehicle off the pallet.
- Position the vehicle on a lift stand.
- Check the vehicle for transport damage.

i Info
The procedure in the event of transport damage is described in the customer service manual.

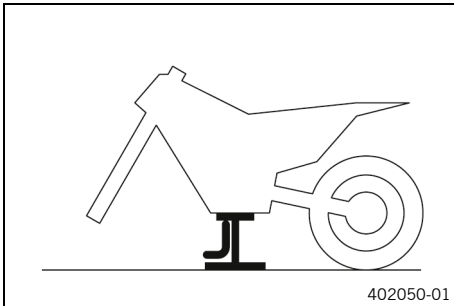

3.2 Removing V2 headlight mask

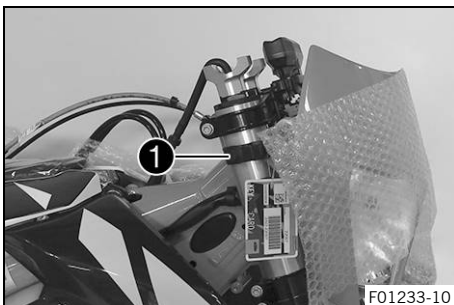

- Remove the spare key and **KEYCODECARD** keep in a safe place for the handover.
- Loosen rubber strap ① and tilt the headlight mask forwards.

3 SERVICE WORK ON THE CHASSIS

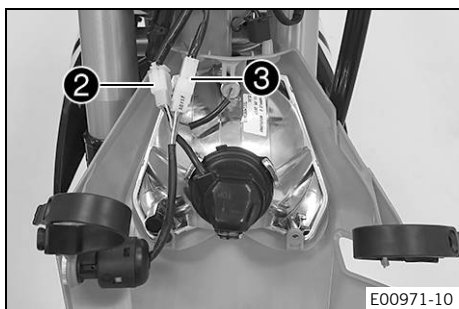

- Disconnect the plug-in connector ② of the headlight and the plug-in connector ③ of the ignition lock.
- Lay down the headlight mask carefully to the side and protect from damage.

3.3 Unpacking and setting up the V12 vehicle

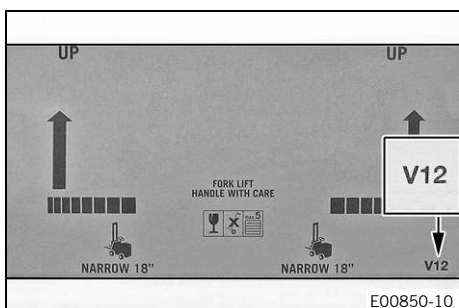

- Remove the box and the plastic packaging.

i Info

An assistant prevents the motorcycle from falling over. To avoid damaging the motorcycle during the setup, leave the protective film on the vehicle until you have finished.

- Remove and unpack the separate enclosure and components. Check that the scope of supply is complete using the enclosed packing list.

i Info

The procedure in the event of missing parts is described in the customer service manual.

- Remove the spare key and **KEYCODECARD** keep in a safe place for the handover.

- Have a lift stand available.

Lift stand (78929955100)

- Remove the two cable ties on the triple clamp.

- Together with an assistant, take the vehicle off the pallet.

- Position the vehicle on a lift stand.

- Check the vehicle and components for transport damage.

i Info

The procedure in the event of transport damage is described in the customer service manual.

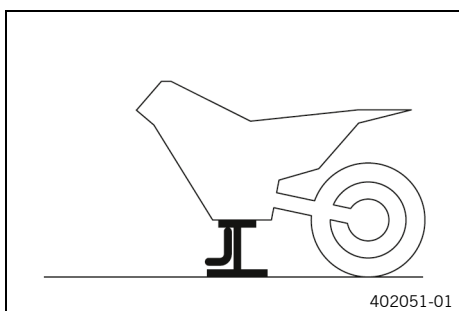

3.4 Installing V12 fork legs

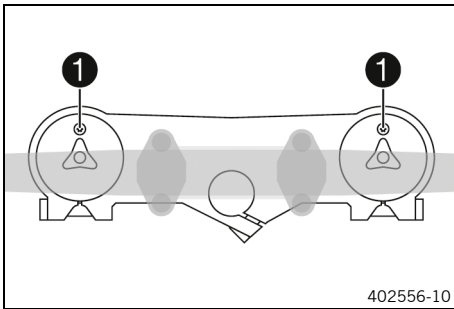

- Position the fork legs.
- ✓ Bleeder screws **1** are positioned toward the front.



Info

Grooves are milled into the side of the upper end of the fork legs. The second milled groove (from the top) must be flush with the upper edge of the upper triple clamp.

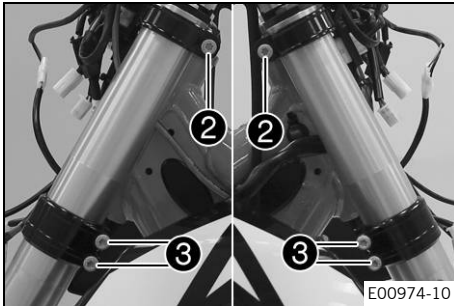

- Tighten screws **2**.

Guideline

Screw, top triple clamp	M8	22 Nm (16.2 lbf ft)
-------------------------	----	---------------------

- Tighten screws **3**.

Guideline

Screw, bottom triple clamp	M8	18 Nm (13.3 lbf ft)
----------------------------	----	---------------------

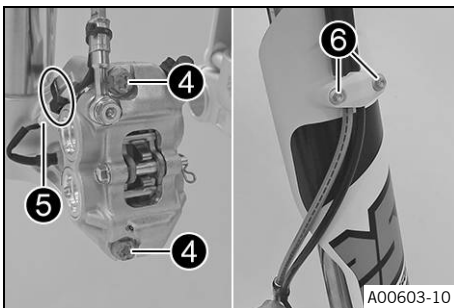

- Position the brake caliper. Mount and tighten screws **4** with the spacers.

Guideline

Screw, front brake caliper	M8	25 Nm (18.4 lbf ft) Loctite®243™
----------------------------	----	--

- Connect plug-in connector **5** and mount the cable tie(s).
- Position the brake line, wiring harness, and clamp. Mount and tighten screws **6**.

3.5 Installing V12 shock absorber

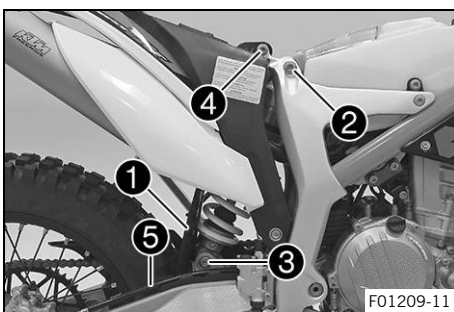

- Push splash protector **1** to the side and position the shock absorber. Mount and tighten screw **2**.

Guideline

Screw, top shock absorber	M12	80 Nm (59 lbf ft) Loctite®2701™
---------------------------	-----	---

- Mount and tighten screw **3**.

Guideline

Screw, bottom shock absorber	M12	80 Nm (59 lbf ft) Loctite®2701™
------------------------------	-----	---



Info

The heim joint for the shock absorber on the link fork is Teflon coated. It must not be lubricated with grease, nor with any other lubricants. Lubricants dissolve the Teflon coating, thereby drastically reducing the service life.

- Mount and tighten screw **4**.

3 SERVICE WORK ON THE CHASSIS

Guideline

Screw, sub-frame top	M10	45 Nm (33.2 lbf ft) Loctite®243™
----------------------	-----	--

- Attach brake line **5**.

3.6 Installing V12 combination instrument

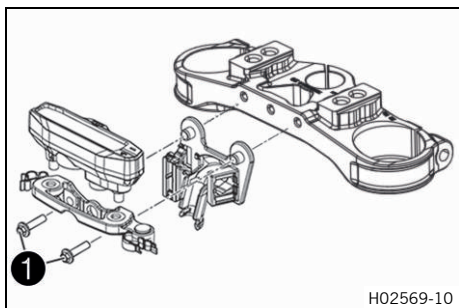

- Position the connector board and combination instrument on the upper triple clamp.
- Mount and tighten screws **1**.

Guideline

Remaining screws, chassis	M6	10 Nm (7.4 lbf ft)
---------------------------	----	--------------------

- Route the clutch line with the clutch master cylinder toward the front between the upper and lower triple clamps.

3.7 Sticking on the reflector

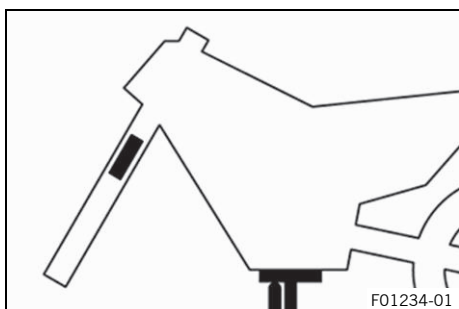

- Make sure that the reflectors are glued on to the left and right fork leg.
 - » If there are no reflectors stuck on:
 - Stick on the reflector.



Info

The reflectors must not be covered by trim parts.

3.8 Installing handlebars

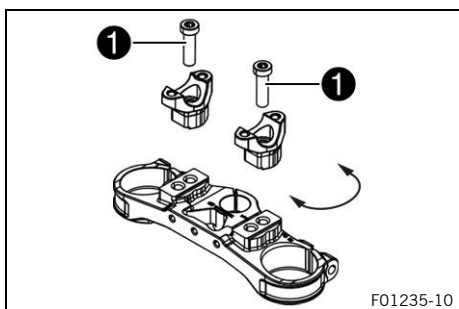

- Remove screws **1**. Take off the handlebar supports.
- Place the handlebar supports in the required position. Mount and tighten screws **1**.

Guideline

Screw, handlebar support	M10	40 Nm (29.5 lbf ft) Loctite®243™
--------------------------	-----	--



Info

Position the left and right handlebar supports evenly.



Warning

Danger of accidents A repaired handlebar poses a safety risk.

If the handlebar is bent or straightened, the material becomes fatigued. The handlebar may break as a result.

- Change the handlebar if the handlebar is damaged or bent.

- Position handlebar.



Info

Make sure the cables and wiring are positioned correctly.

- Position handlebar clamps. Mount and tighten the screws evenly.

Guideline

Screw, handlebar clamp	M8	20 Nm (14.8 lbf ft)
------------------------	----	---------------------



Info

The handlebar clamps and screws are in the accessory pack.

The markings on the handlebar should be at the center of the handlebar clamps.

Keep the installed gap widths equal when tightening.



3.9 Installing the handlebar cushion



- Secure the handlebar cushion with two cable ties.



3 SERVICE WORK ON THE CHASSIS

3.10 Installing left side controls

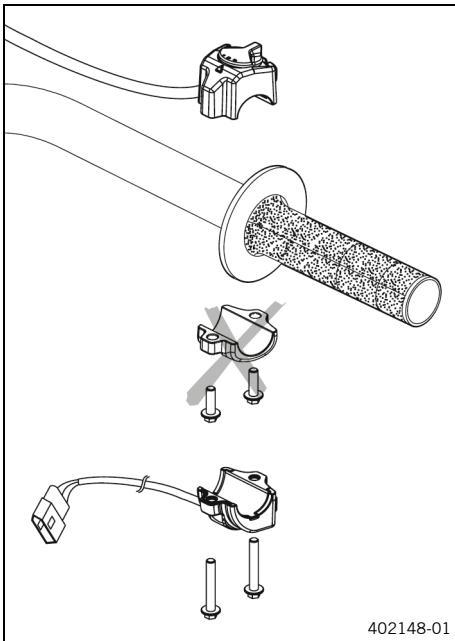

- Mount turn signal switch and route cable to the front.

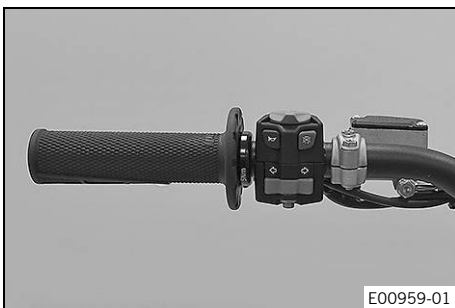

- Position the controls on the left half of the handlebar.

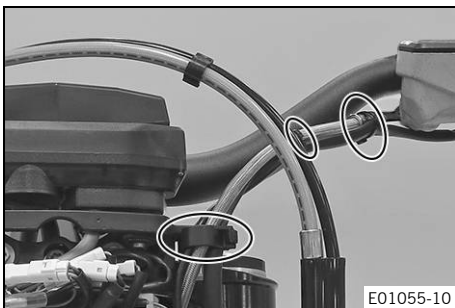

- Route the cables without tension and secure with cable ties and cable holders.



Condition

Customer request: non-approved installation for road use.



Warning

Voiding of the government approval for road use and the insurance coverage If the combination switch is mounted, the vehicle's road permit, if any, expires.

- Only operate the vehicle in closed-off areas remote from public road traffic if the combination switch is installed.

- Mount left side combination switch.

Combination switch, left side (79039974044)



Info

The left side combination switch is optionally available as an accessory.

With the combination switch mounted the second mapping and traction control can be used.

The figure shows a possible installation position of the left side combination switch.

Observe the accompanying **KTM PowerParts** fitting instructions.

The launch control is not available for this model.

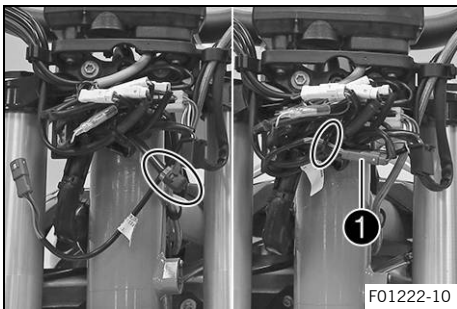

- Remove the protection cap and join plug-in connector ① of the left combination switch.
- Route the cable without tension and secure with cable tie(s).

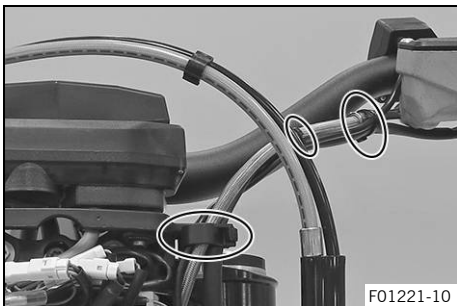

- Route the cables without tension and secure with cable ties and cable holders.



3 SERVICE WORK ON THE CHASSIS

3.11 Installing right side controls

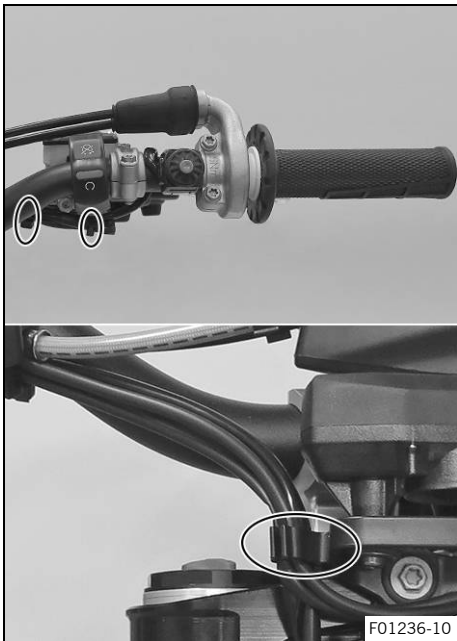

- Position the controls on the right half of the handlebar.
- Route the cables without tension and secure with cable ties and cable holders.

3.12 Installing left and right rear mirrors

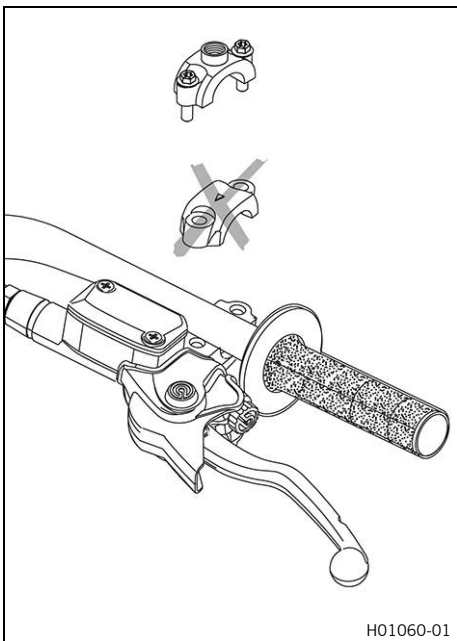

- Mount the mirror clamps on both sides.

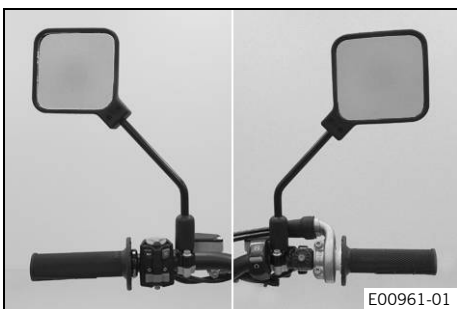

- Mount and tighten the rear mirror on both sides.

3.13 Installing hand guards left and right

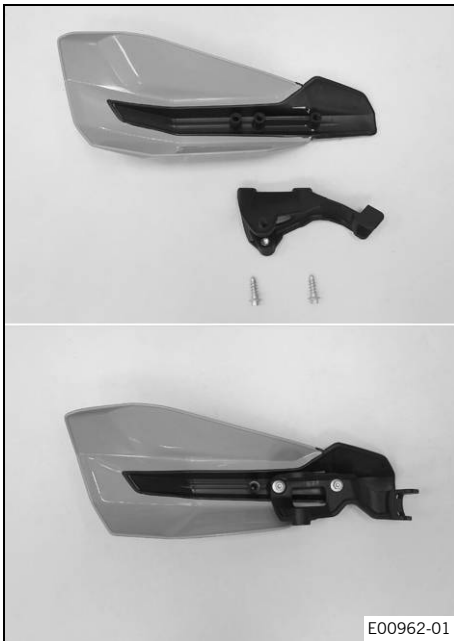

- Preassemble the hand guards on the left and right.

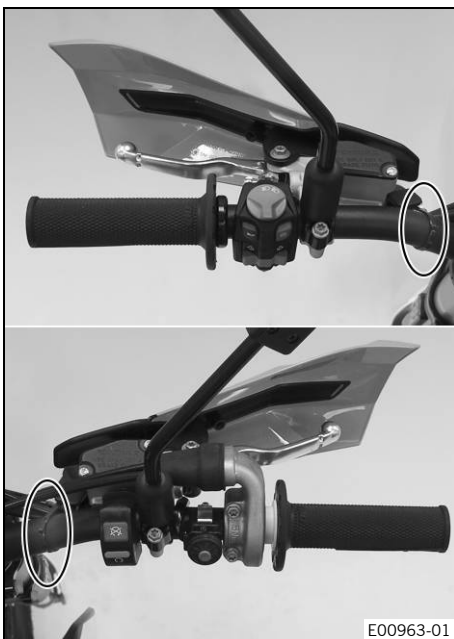

- Mount the left hand guard.
- Mount the right hand guard.



3 SERVICE WORK ON THE CHASSIS

3.14 Installing front fender

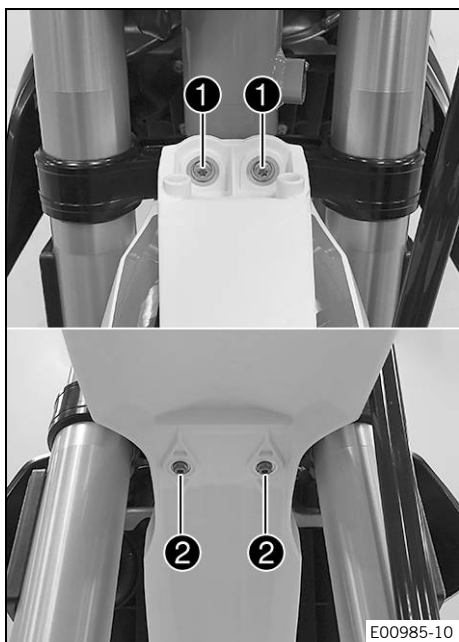

- Position front fender. Mount and tighten screws **1**.

Guideline

Remaining screws, chassis	M6	10 Nm (7.4 lbf ft)
---------------------------	----	--------------------

- Mount and tighten screws **2**.

Guideline

Remaining screws, chassis	M6	10 Nm (7.4 lbf ft)
---------------------------	----	--------------------

3.15 Installing the front wheel



Warning

Danger of accidents Oil or grease on the brake discs reduces the braking effect.

- Always keep the brake discs free of oil and grease.
- Clean the brake discs with brake cleaner when necessary.

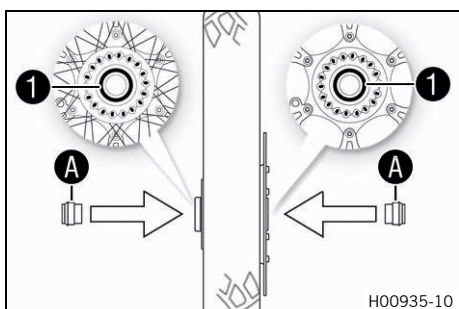

- Check the wheel bearing for damage and wear.
 - » If the wheel bearing is damaged or worn:
 - Change front wheel bearing.
- Clean and grease shaft seal rings **1** and contact surfaces **A** of the spacers.

Long-life grease (🔧 p. 33)

- Insert the spacers.
- Clean and grease the wheel spindle.

Long-life grease (🔧 p. 33)

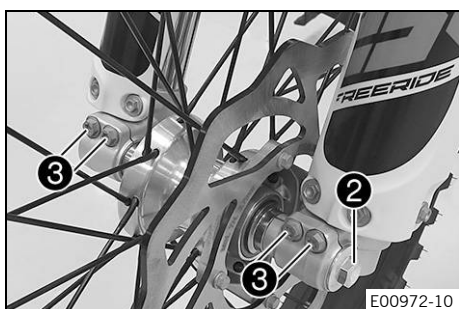

- Position the front wheel and insert the wheel spindle.
 - ✓ The brake linings are correctly positioned.
- Mount and tighten screw **2**.

Guideline

Screw, front wheel spindle	M20x1.5	35 Nm (25.8 lbf ft)
----------------------------	---------	---------------------

- Operate the hand brake lever several times until the brake linings are seated correctly against the brake disc.
- Remove the motorcycle from the lift stand. (🔧 p. 20)

- Operate the front brake and compress the fork a few times firmly.
- ✓ The fork legs straighten.
- Tighten screws ③.

Guideline

Screw, fork stub	M8	15 Nm (11.1 lbf ft)
------------------	----	---------------------



3.16 Installing front and rear turn signals

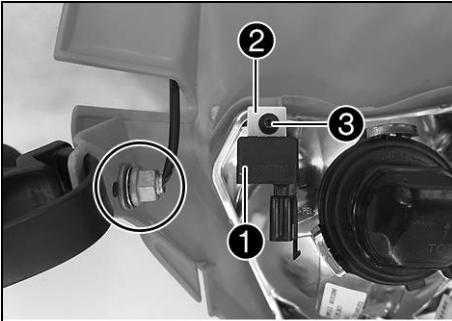

- Position the turn signal on the headlight mask on both sides, mount nuts with washers and tighten.
- Mount turn signal relay ① with lock washer ② and screw ③.

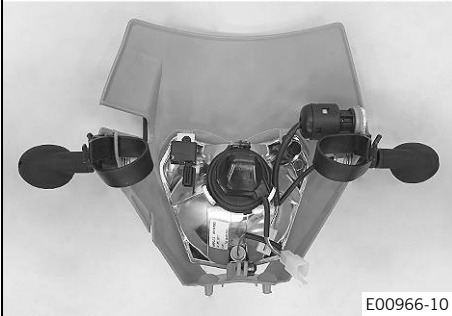

E00966-10

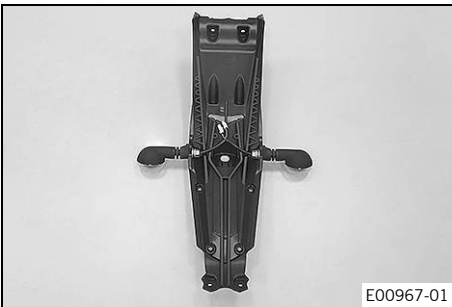

E00967-01

- Position the turn signal on both sides on the license plate holder, mount nuts with washers and tighten.



3.17 Installing the license plate lamp

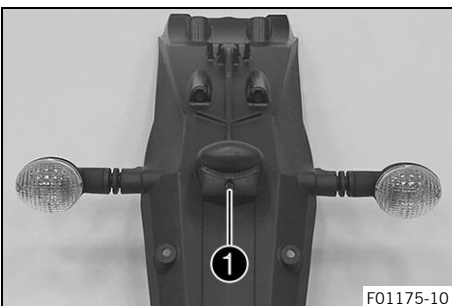

F01175-10

- Position the license plate lamp on the license plate holder extension, and mount and tighten screw ①.



3 SERVICE WORK ON THE CHASSIS

3.18 Installing the reflector

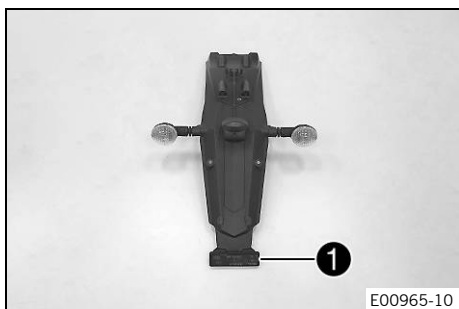

- Mount reflector **1** on the license plate holder with the spring washer.

3.19 Routing the front turn signal cable

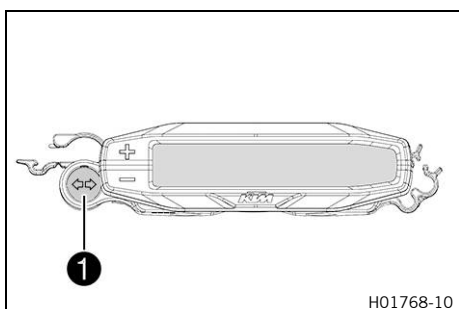

- Position turn signal indicator lamp **1** in the combination instrument rack.

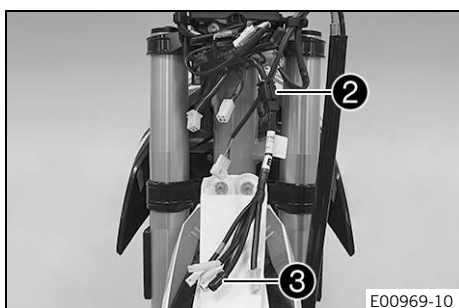

- Join plug-in connector **2** of the turn signal cable.
- Make sure that the bulb is located in socket **3**.
 - » If there is no bulb in the socket:
 - Insert the bulb included in the accessory pack in socket **3**.

Indicator lamps (W2.3W / socket W2x4.6d)

- Position the cable with socket and bulb in turn signal control lamp **1**.

3.20 Routing the rear turn signal cable

Preparatory work

- Fold the seat up. (📖 p. 18)

Main work

- Pull EFI control unit **1** off the holder and hang to the side.

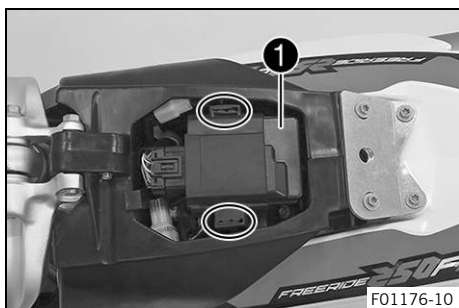

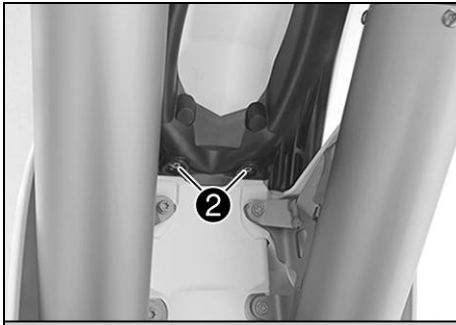

- Remove screws ②.
- Remove screws ③.
- Lower the license plate holder and hang the tail light to the side.

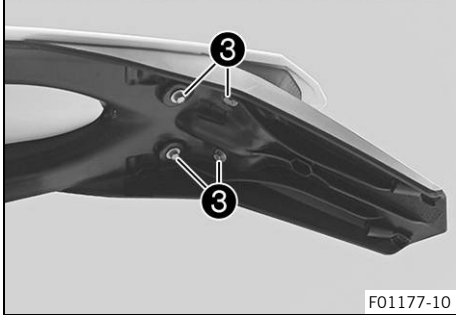

F01177-10

i Info
Pay attention to the cable of the tail light.

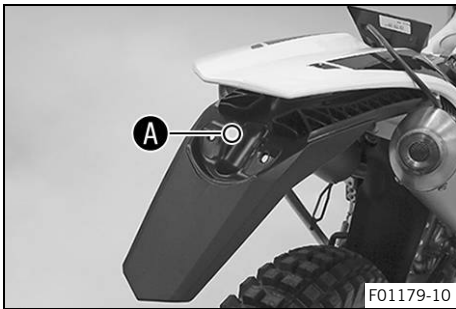

F01179-10

- Drill a hole at marking ① to the size of the marking.

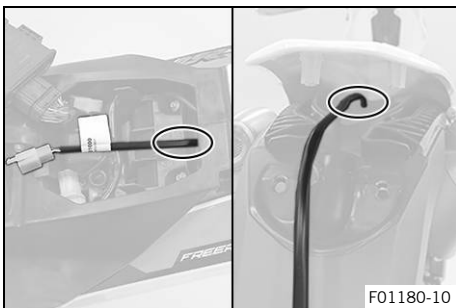

F01180-10

- Route the turn signal cable harness through the frame from the front to the rear paying attention to the plugs as you do so.

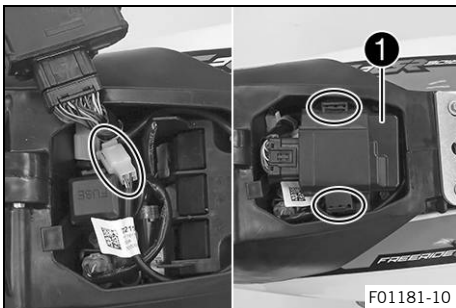

F01181-10

- Join the turn signal cable harness plug-in connector to the wiring harness plug-in connector.
- Mount EFI control unit ① on the holder.

i Info
The wiring harness runs under the EFI control unit.

- Lock the seat. (📖 p. 19)

3 SERVICE WORK ON THE CHASSIS



- Route the turn signal cable on the left side on the license plate holder and feed the turn signal cable through the hole.
- Route the cable of the tail light on the right side on the license plate holder.

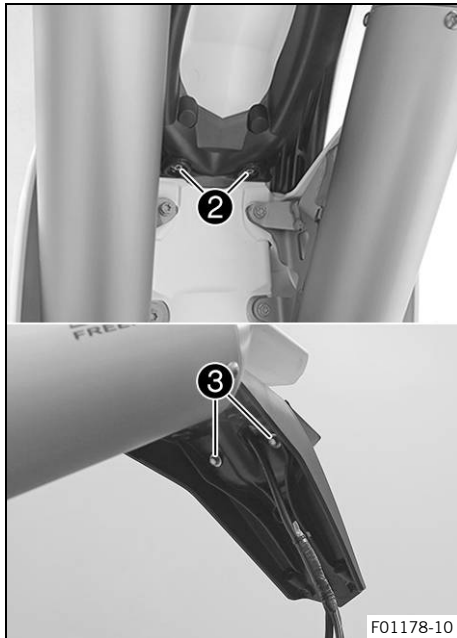

- Position the license plate holder on the rear.



Info

Ensure that the cable is routed correctly.

- Mount and tighten screws **2**.

Guideline

Remaining screws, chassis	M6	10 Nm (7.4 lbf ft)
---------------------------	----	--------------------

- Position the tail light on the license plate holder.
- Mount and tighten screws **3**.

3.21 Folding the seat up



- Press release lever **1**.
- Lift the seat and fold it up.

3.22 Locking the seat

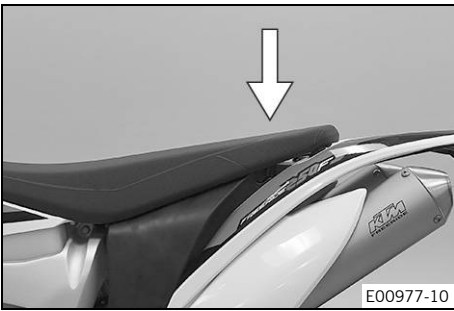

- Fold down the seat and push it down.
- ✓ The seat engages with an audible click.
- Check that the seat is correctly locked.



3.23 Installing the license plate holder extension

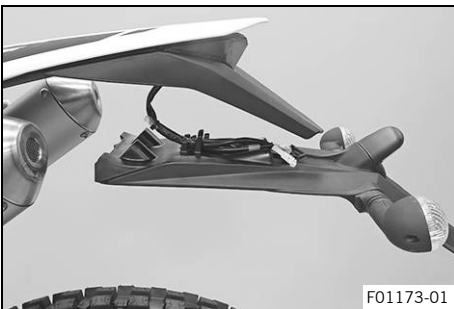

- Route turn signal cable to the rear through the license plate holder extension.



- Make sure that the bulb is located in the socket.
 - » If there is no bulb in the socket:
 - Insert the bulb included in the accessory pack in the socket.
- License plate lamp (W5W/socket W2.1x9.5d)
- Insert the cable with the socket and bulb in the license plate lamp.
 - Connect the plug-in connector of the left turn signal which is marked red.
 - Connect the plug-in connector of the right turn signal which is marked green.
 - Position the license plate holder extension on the license plate holder.



Info

Make sure the cables and plug-in connections are positioned correctly.

- Mount and tighten screws ①.



3 SERVICE WORK ON THE CHASSIS

3.24 Removing the motorcycle from the lift stand

Note

Danger of damage The parked vehicle can roll away or fall over.

- Park the vehicle on a firm and level surface.

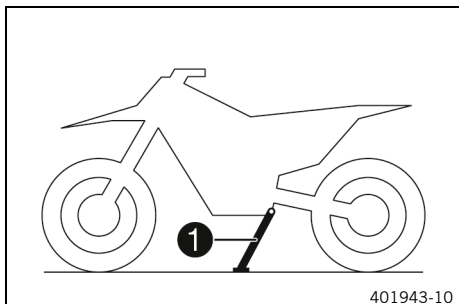

- Remove the motorcycle from the lift stand.
- Remove the lift stand.
- To park the motorcycle, press side stand **1** to the ground with your foot and lean the motorcycle on it.

Info

When you are riding, the side stand must be folded up and secured with the rubber strap.

3.25 Installing the engine guard

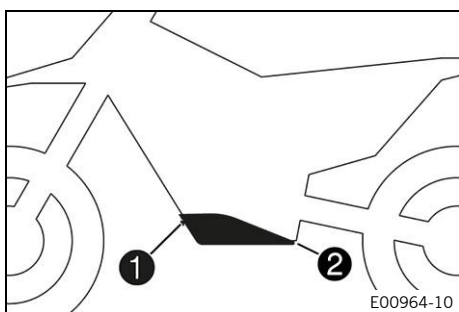

- Position the engine guard on the frame at the front and mount screws **1** but do not tighten yet.
- Position the engine guard on the frame at the rear and mount and tighten screws **2**.

Guideline

Screw, engine guard	M6x20	10 Nm (7.4 lbf ft)
---------------------	-------	--------------------

- Tighten screws **1**.

Guideline

Screw, engine guard	M6x12	10 Nm (7.4 lbf ft)
---------------------	-------	--------------------

3.26 Installing the footrests

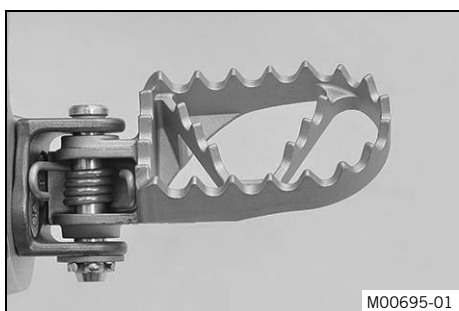

- Mount the left footrest and the right footrest with the springs and pins. Secure the pins using the washers and cotter pins.

Footrest spring plier (58429083000)

3.27 Disconnecting the negative cable of the 12 V battery

Preparatory work

- Turn the ignition key in the ignition lock to the position \otimes while the engine is idling.

Main work

- Remove screw ①.
- Remove battery cover ②.

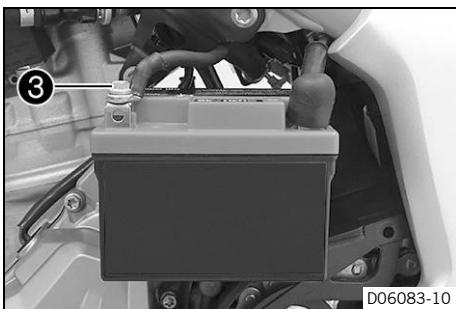
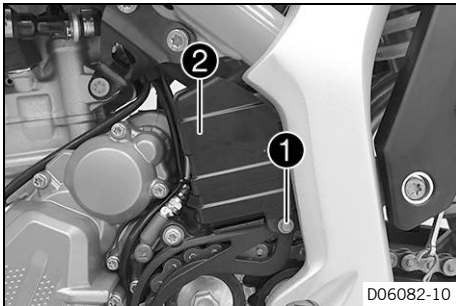

- Remove the 12-V battery from the battery compartment.



Warning

Risk of injury 12 V batteries contain harmful substances.

- Keep 12 V batteries out of the reach of children.
- Keep sparks and open flames away from 12 V batteries.
- Only charge 12 V batteries in well-ventilated rooms.
- Maintain a minimum clearance from inflammable materials when charging 12 V batteries.
Minimum clearance 1 m (3 ft)
- Do not charge deeply discharged 12 V batteries if the charge is already below the minimum voltage.
Minimum voltage before 9 V the start of the charge
- Dispose of 12 V batteries with less than the minimum voltage correctly.

- Disconnect negative cable ③ from the 12-V battery.



3 SERVICE WORK ON THE CHASSIS

3.28 Connecting the negative cable of the 12 V battery

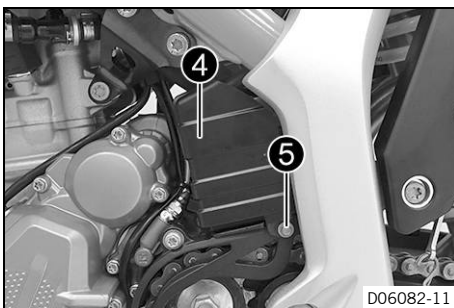
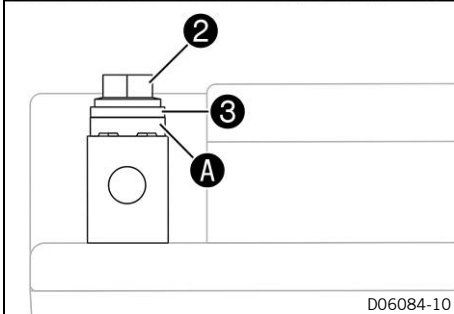
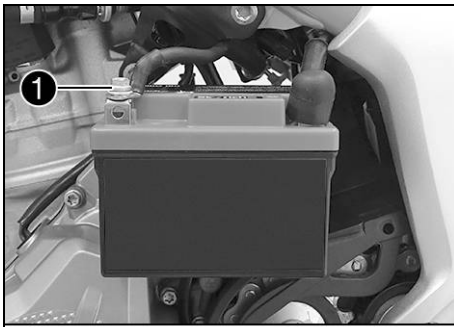

- Connect negative cable ① of the 12 V battery.

Guideline

Screw, battery terminal	M5	2.5 Nm (1.84 lbf ft)
-------------------------	----	-------------------------

Contact disk **A** must be mounted under screw ② and cable lug ③ with the claws toward the battery terminal.

- Position the 12-V battery in the battery compartment.
- Insert battery cover ④.
- Mount and tighten screw ⑤.

3.29 Charging the 12 V battery



Warning

Risk of injury 12 V batteries contain harmful substances.

- Keep 12 V batteries out of the reach of children.
- Keep sparks and open flames away from 12 V batteries.
- Only charge 12 V batteries in well-ventilated rooms.
- Maintain a minimum clearance from inflammable materials when charging 12 V batteries.
Minimum clearance 1 m (3 ft)
- Do not charge deeply discharged 12 V batteries if the charge is already below the minimum voltage.
Minimum voltage before the start of the charge 9 V
- Dispose of 12 V batteries with less than the minimum voltage correctly.



Note

Environmental hazard 12 V batteries contain environmentally hazardous materials.

- Do not dispose of 12 V batteries as household waste.
- Dispose of 12 V batteries at a collection point for used batteries.



Note

Environmental hazard Hazardous substances cause environmental damage.

- Dispose of oils, grease, filters, fuel, cleaning agents, brake fluid, etc., correctly and in compliance with the applicable regulations.



Info

Even when there is no load on the 12 V battery, it discharges steadily. The charging level and the method of charging are very important for the service life of the 12 V battery. Rapid recharging with a high charging current shortens the service life of the battery. If the charging current, charging voltage, and charging time are exceeded, the 12 V battery will be destroyed. If the 12 V battery is depleted from starting the vehicle repeatedly, the battery must be charged immediately. If the 12 V battery is left in a discharged state for an extended period, it will become deeply discharged and suffer a loss of capacity, destroying the battery. The 12 V battery is maintenance-free.

Preparatory work

- Turn the ignition key in the ignition lock to the position ☒ while the engine is idling.
- Disconnect the negative cable of the 12 V battery. (📖 p. 21)

Main work

- Connect the battery charger to the 12 V battery. Adjust the battery charger.

EU battery charger **XCharge-professional** (00029095050)

Alternative 1

US battery charger **XCharge-professional** (00029095051)

Alternative 2

UK battery charger **XCharge-professional** (00029095052)

Alternative 3

CH battery charger **XCharge-professional** (00029095053)

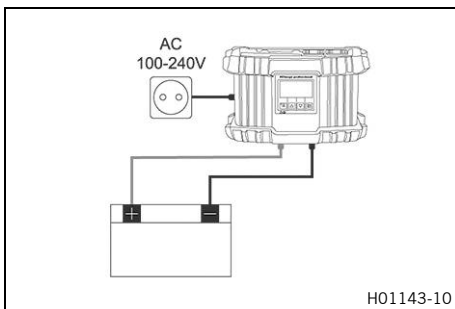

Info

Follow the instructions of the charger and the manual.

- Disconnect the battery charger after charging the 12 V battery.

Guideline

The charging current, charging voltage, and charging time must not be exceeded.

Recharge the 12 V battery regularly when the motorcycle is not being used	3 months
---	----------

Finishing work

- Connect the negative cable of the 12 V battery. (📖 p. 22)



3.30 Installing the headlight mask with the headlight

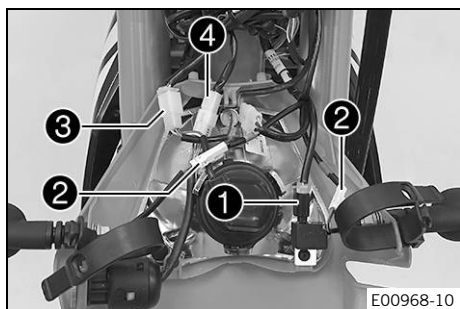

Main work

- Join plug-in connector **1** of the turn signal relay, plug-in connectors **2** of the turn signals, plug-in connector **3** of the headlight and plug-in connector **4** of the ignition lock.

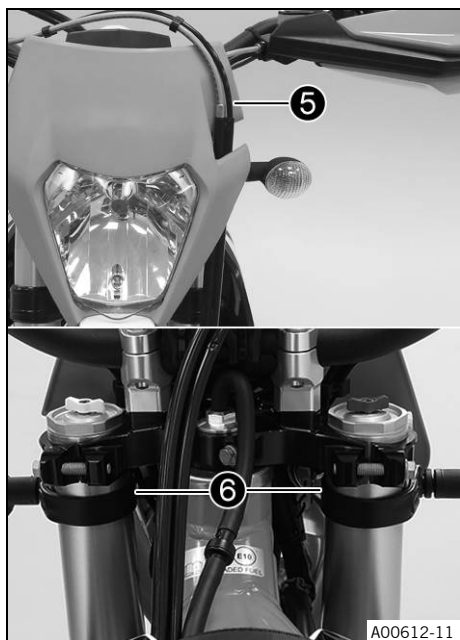

- Attach the brake line and wiring harness **5**.
- Position the headlight mask and secure it with rubber straps **6**.
- ✓ The holding lugs on the fender engage in the headlight mask.

Finishing work

- Check the headlight setting. (📖 p. 24)

3.31 Checking the headlight setting

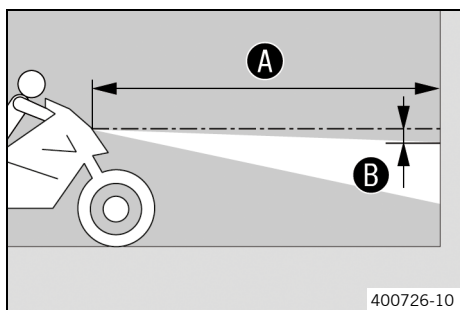

- Position the vehicle upright on a horizontal surface in front of a light wall and make a marking at the height of the center of the low beam headlight.

- Make another mark at a distance **B** under the first marking.
Guideline

Distance B	5 cm (2 in)
-------------------	-------------

- Position the vehicle vertically at a distance **A** away from the wall.
Guideline

Distance A	5 m (16 ft)
-------------------	-------------

- Sit on the motorcycle.
- Switch on the low beam.
- Check the headlight setting.

The boundary between light and dark must be exactly on the lower mark for a motorcycle with rider.

- » If the boundary between light and dark does not meet specifications:
 - Adjust the headlight range. (📖 p. 25)



3.32 Adjusting the headlight range



Preparatory work

- Check the headlight setting. (📖 p. 24)

Main work

- Loosen screw ①.
- Adjust the headlight range by pivoting the headlight.

Guideline

The boundary between light and dark must be exactly on the lower mark for a motorcycle with rider (instructions on how to apply the mark: Checking the headlight setting).

i Info
A change in weight on the vehicle may require a correction of the headlight range.

- Tighten screw ①.



3.33 Setting the combination instrument

i Info
When the vehicle is delivered, only the **SPEED/H** and **SPEED/ODO** display modes are activated.

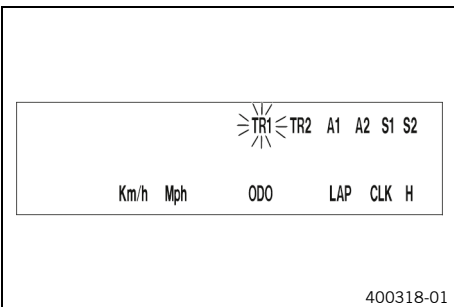

Condition

The motorcycle is stationary.

- Repeatedly press the button **+** briefly until **H** appears at the bottom right of the display.
- Press the button **+** for 2–3 seconds.
- ✓ The Setup menu is displayed and the active functions are shown.

i Info
If no button is pressed for 10 - 12 seconds, the settings are automatically saved.
If no button is pressed for 20 seconds, or if an impulse comes from the wheel speed sensor, the settings are automatically saved and the setup menu is closed.

- Repeatedly press the button **+** briefly until the desired function flashes.
- ✓ The selected function flashes.

Activating the function

- Press the button **+**.

3 SERVICE WORK ON THE CHASSIS

- ✓ The symbol continues to appear in the display and the next function appears.

Deactivating a function

- Press the button .
- ✓ The symbol disappears in the display and the next function appears.

3.34 Setting the kilometers or miles

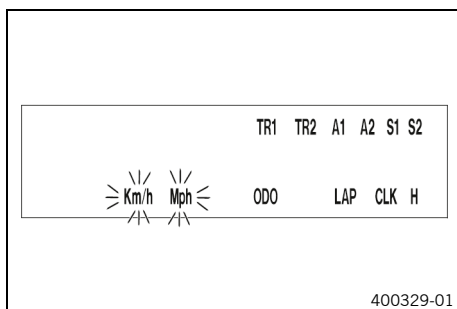

Info

If you change the unit, the value **ODO** is retained and converted accordingly.
The values **TR1**, **TR2**, **A1**, **A2** and **S1** are cleared when the unit of measure is changed.



Condition

The motorcycle is stationary.

- Repeatedly press the button  briefly until **H** appears at the bottom right of the display.
- Press the button  for 2–3 seconds.
 - ✓ The Setup menu is displayed and the active functions are shown.
- Repeatedly press the button  briefly until **Km/h / Mph** flashes.

Adjusting the Km/h

- Press the button .

Adjusting the Mph

- Press the button .
- Wait 3 - 5 seconds.
 - ✓ The settings are stored.

Info





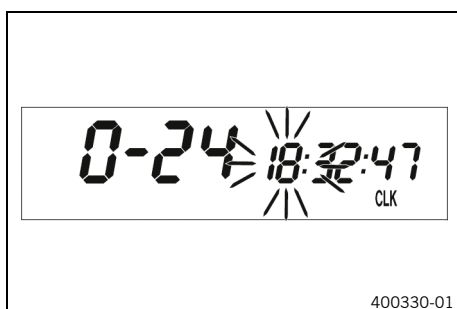

If no button is pressed for 10–12 seconds, or if an impulse comes from the wheel speed sensor, the settings are automatically saved and the setup menu is closed.

3.35 Setting the clock



Condition

The motorcycle is stationary.

- Repeatedly press the button  briefly until **CLK** appears at the bottom right of the display.
- Press the button  for 2–3 seconds.
 - ✓ The hour display flashes.
- Adjust the hour display with the button  and/or button .
- Wait 3 - 5 seconds.
 - ✓ The next segment of the display flashes and can be set.
- You can set the following segments in the same way as the hours by pressing the button  and the button .

**Info**

The seconds can only be set to zero. If no button is pressed for 15–20 seconds, or if an impulse comes from the wheel speed sensor, the settings are automatically saved and the setup menu is closed.

**3.36 Refueling****Danger**

Fire hazard Fuel is highly flammable.

The fuel in the fuel tank expands when warm and can escape if overfilled.

- Do not refuel the vehicle in the vicinity of open flames or lit cigarettes.
- Switch off the engine for refueling.
- Make sure that no fuel is spilled; particularly not on hot parts of the vehicle.
- If any fuel is spilled, wipe it off immediately.
- Observe the specifications for refueling.

**Warning**

Danger of poisoning Fuel is poisonous and a health hazard.

- Avoid skin, eye and clothing contact with fuel.
- Immediately consult a doctor if you swallow fuel.
- Do not inhale fuel vapors.
- In case of skin contact, rinse the affected area with plenty of water.
- Rinse the eyes thoroughly with water, and consult a doctor in case of fuel contact with the eyes.
- Change your clothing in case of fuel spills on them.

Note

Material damage Inadequate fuel quality causes the fuel filter to quickly become clogged.

In some countries and regions, the available fuel quality and cleanliness may not be sufficient. This will result in problems with the fuel system.

- Refuel only with clean fuel that meets the specified standards.

**Note**

Environmental hazard Improper handling of fuel is a danger to the environment.

- Do not allow fuel to enter the groundwater, the soil, or the sewage system.

Preparatory work

- Switch off the engine.
- Fold the seat up. (📖 p. 18)
- Open fuel tank filler cap. (📖 p. 28)

3 SERVICE WORK ON THE CHASSIS

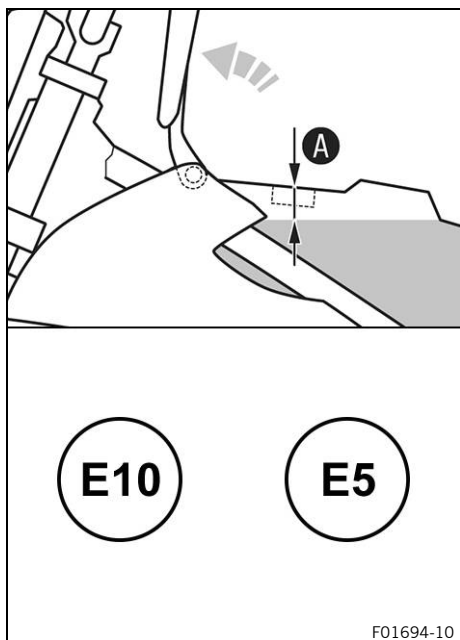

Main work

- Fill the fuel tank with fuel up to measurement **A**.

Guideline

Measurement of A	30 mm (1.18 in)	
Total fuel tank capacity, approx.	5 l (1.3 US gal)	Super unleaded (ROZ 95/RON 95/PON 91) (📖 p. 32)

Finishing work

- Close the fuel tank filler cap. (📖 p. 29)
- Lock the seat. (📖 p. 19)

3.37 Opening fuel tank filler cap



Danger

Fire hazard Fuel is highly flammable.

The fuel in the fuel tank expands when warm and can escape if overfilled.

- Do not refuel the vehicle in the vicinity of open flames or lit cigarettes.
- Switch off the engine for refueling.
- Make sure that no fuel is spilled; particularly not on hot parts of the vehicle.
- If any fuel is spilled, wipe it off immediately.
- Observe the specifications for refueling.



Warning

Danger of poisoning Fuel is poisonous and a health hazard.

- Avoid skin, eye and clothing contact with fuel.
- Immediately consult a doctor if you swallow fuel.
- Do not inhale fuel vapors.
- In case of skin contact, rinse the affected area with plenty of water.
- Rinse the eyes thoroughly with water, and consult a doctor in case of fuel contact with the eyes.
- Change your clothing in case of fuel spills on them.
- Keep fuels correctly in a suitable canister, and out of the reach of children.



Note

Environmental hazard Improper handling of fuel is a danger to the environment.

- Do not allow fuel to enter the groundwater, the soil, or the sewage system.

Preparatory work

- Fold the seat up. (📖 p. 18)

Main work

- Press release button ①, turn the fuel tank filler cap counter-clockwise, and lift it off.

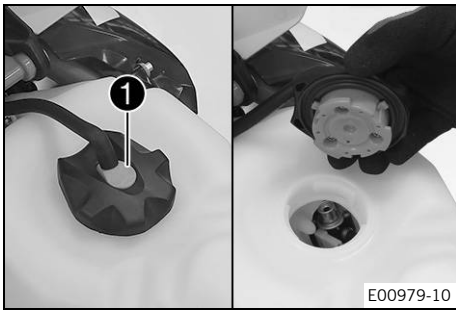

3.38 Closing the fuel tank filler cap

Main work

- Mount fuel tank filler cap and turn it clockwise until the release button ① engages.



Info

Route the fuel tank breather hose ② without kinks.

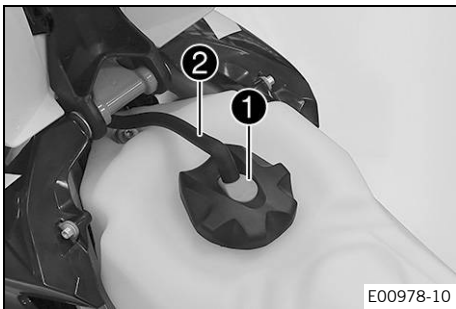

Finishing work

- Lock the seat. (📖 p. 19)

4 TECHNICAL DATA

4.1 Chassis tightening torques

Screw for spoiler, top	EJOT PT® K60x20AL	3 Nm (2.2 lbf ft)
Screw, front spoiler	EJOT PT® K60x30-Z	3 Nm (2.2 lbf ft)
Screw, pressure regulator	EJOT PT® K60x25-Z	2.3 Nm (1.7 lbf ft)
Screw, fixed grip	M4	5 Nm (3.7 lbf ft) Loctite®243™
Spoke nipple	M4.5	6 Nm (4.4 lbf ft)
Screw, battery terminal	M5	2.5 Nm (1.84 lbf ft)
Screw, intake air temperature sensor	M5	2 Nm (1.5 lbf ft)
Screw, shock absorber adjusting ring	M5	5 Nm (3.7 lbf ft)
Screws on main silencer	M5	7 Nm (5.2 lbf ft)
Nut, cable on starter motor	M6	4 Nm (3 lbf ft)
Remaining nuts, chassis	M6	10 Nm (7.4 lbf ft)
Remaining screws, chassis	M6	10 Nm (7.4 lbf ft)
Screw for spoiler attachment	M6	5 Nm (3.7 lbf ft)
Screw, ball joint of push rod on foot brake cylinder	M6	10 Nm (7.4 lbf ft) Loctite®243™
Screw, engine guard	M6x20	10 Nm (7.4 lbf ft)
Screw, engine guard	M6x12	10 Nm (7.4 lbf ft)
Screw, foot brake cylinder	M6	10 Nm (7.4 lbf ft) Loctite®243™
Screw, front brake disc	M6	14 Nm (10.3 lbf ft) Loctite®243™
Screw, radiator bracket	M6	6 Nm (4.4 lbf ft)
Screw, rear brake disc	M6	14 Nm (10.3 lbf ft) Loctite®243™
Screws, throttle grip	M6	5 Nm (3.7 lbf ft)
Fuel connection on fuel pump	M8	10 Nm (7.4 lbf ft)
Nut, foot brake lever stop	M8	20 Nm (14.8 lbf ft)
Nut, rear sprocket screw	M8	35 Nm (25.8 lbf ft) Loctite®2701™
Nut, rim lock	M8	10 Nm (7.4 lbf ft)
Remaining nuts, chassis	M8	25 Nm (18.4 lbf ft)
Remaining screws, chassis	M8	25 Nm (18.4 lbf ft)
Screw, bottom triple clamp	M8	18 Nm (13.3 lbf ft)
Screw, chain sliding piece	M8	15 Nm (11.1 lbf ft)
Screw, engine brace on cylinder head	M8	25 Nm (18.4 lbf ft) Loctite®2701™
Screw, engine brace on frame	M8	25 Nm (18.4 lbf ft) Loctite®2701™
Screw, fork stub	M8	15 Nm (11.1 lbf ft)
Screw, front brake caliper	M8	25 Nm (18.4 lbf ft) Loctite®243™
Screw, fuel tank	M8	15 Nm (11.1 lbf ft) Loctite®243™

Screw, handlebar clamp	M8	20 Nm (14.8 lbf ft)
Screw, main silencer	M8x20	25 Nm (18.4 lbf ft)
Screw, main silencer	M8x25	25 Nm (18.4 lbf ft)
Screw, rear brake caliper	M8	25 Nm (18.4 lbf ft) Loctite®243™
Screw, side stand attachment	M8	25 Nm (18.4 lbf ft) Loctite®2701™
Screw, subframe	M8	30 Nm (22.1 lbf ft) Loctite®243™
Screw, top steering stem	M8	17 Nm (12.5 lbf ft) Loctite®243™
Screw, top triple clamp	M8	22 Nm (16.2 lbf ft)
Engine bracket screw	M10	60 Nm (44.3 lbf ft)
Nut, fuel tank attachment	M10	10 Nm (7.4 lbf ft)
Remaining nuts, chassis	M10	45 Nm (33.2 lbf ft)
Remaining screws, chassis	M10	45 Nm (33.2 lbf ft)
Screw, battery compartment	M10	45 Nm (33.2 lbf ft)
Screw, cross bar	M10	45 Nm (33.2 lbf ft)
Screw, foot brake lever	M10	30 Nm (22.1 lbf ft) Loctite®243™
Screw, footrest bracket	M10	45 Nm (33.2 lbf ft) Loctite®243™
Screw, handlebar support	M10	40 Nm (29.5 lbf ft) Loctite®243™
Screw, subframe top	M10	45 Nm (33.2 lbf ft) Loctite®243™
Nut, fuel pump fixation	M12	15 Nm (11.1 lbf ft)
Screw, bottom shock absorber	M12	80 Nm (59 lbf ft) Loctite®2701™
Screw, top shock absorber	M12	80 Nm (59 lbf ft) Loctite®2701™
Nut, swingarm pivot	M14x1.5	75 Nm (55.3 lbf ft)
Nut, rear wheel spindle	M20x1.5	80 Nm (59 lbf ft)
Screw, front wheel spindle	M20x1.5	35 Nm (25.8 lbf ft)
Screw, top steering head	M20x1.5	12 Nm (8.9 lbf ft)

Super unleaded (ROZ 95/RON 95/PON 91)

Standard/classification

- DIN EN 228 (ROZ 95/RON 95/PON 91)

Guideline

- Only use unleaded super fuel that matches or is equivalent to the specified fuel grade.
- Fuel with an ethanol content of up to 10 % (E10 fuel) is safe to use.



Info

Do **not** use fuel containing methanol (e. g. M15, M85, M100) or more than 10 % ethanol (e. g. E15, E25, E85, E100).

Long-life grease

Recommended supplier

MOTOREX®

– Bike Grease 2000

READY TO RACE

>> www.ktm.com



3214152en

08/2019



KTM

KTM Sportmotorcycle GmbH
5230 Mattighofen/Austria
<http://www.ktm.com>



Photo: Mitterbauer/KISKA/KTM