

790 Adventure

Art. no. 3214165en



KTM

Perform the work described in these setup instructions before the vehicle is delivered to the customer.

Read the setup instructions in their entirety before beginning work.

These setup instructions were written to correspond to the latest state of this series. We reserve the right to make changes in the interest of technical advancement without at the same time updating this manual. We shall not provide a description of general workshop methods. Likewise, safety rules that apply in a workshop are not specified here. It is assumed that the work will be performed by a fully trained mechanic.

All specifications contained herein are non-binding. KTM Sportmotorcycle GmbH specifically reserves the right to modify or delete technical specifications, prices, colors, forms, materials, services, designs, equipment, etc., without prior notice and without specifying reasons, to adapt these to local conditions, as well as to stop production of a particular model without prior notice. KTM accepts no liability for delivery options, deviations from figures and descriptions, misprints, and other errors. The models portrayed partly contain special equipment that does not belong to the regular scope of supply.

© 2019 KTM Sportmotorcycle GmbH, Mattighofen Austria

All rights reserved

Reproduction, even in part, as well as copying of all kinds, is permitted only with the express written permission of the copyright owner.



ISO 9001(12 100 6061)

KTM applies quality assurance processes that lead to the highest possible product quality as defined in the ISO 9001 international quality management standard.

Issued by: TÜV Management Service

REG.NO. 12 100 6061

KTM Sportmotorcycle GmbH

Stallhofnerstraße 3

5230 Mattighofen, Austria

This document is valid for the following models:

790 Adventure EU (F9603T1, F9603T2)

790 Adventure US (F9675T1, F9675T2)

790 Adventure ASEAN (F9688T1)

790 Adventure CN (F9687T1, F9687TA)

790 Adventure PH (F9682TA)



1 MEANS OF REPRESENTATION

1.1 Symbols used

The meaning of specific symbols is described below.



Indicates an expected reaction (e.g. of a work step or a function).



Indicates an unexpected reaction (e.g. of a work step or a function).



Indicates a page reference (more information is provided on the specified page).



Indicates information with more details or tips.



Indicates the result of a testing step.



Indicates a voltage measurement.



Indicates a current measurement.



Indicates a resistance measurement.



Indicates the end of an activity including potential rework.

1.2 Formats used

The typographical formats used in this document are explained below.

Proprietary name

Indicates a proprietary name.

Name®

Indicates a protected name.

Brand™

Indicates a brand available on the open market.

Underlined terms

Refer to technical details of the vehicle or indicate technical terms, which are explained in the glossary.

2.1 Transport mode

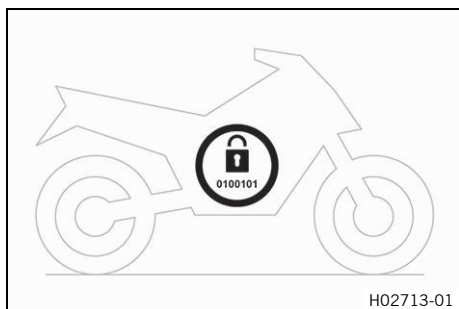

This vehicle was blocked for transport in the software. To operate the vehicle, the vehicle electronics must be enabled. This process is conducted during initial setup in KTM Dealer.net. Enabling ensures that the initial setup in KTM Dealer.net is documented.

Enabling can be performed either temporarily, e.g. for a test ride, or permanently for vehicle handover.

i Info

Make sure that the vehicle is permanently enabled before handing it over to the customer.

2.2 Diagnostics connector

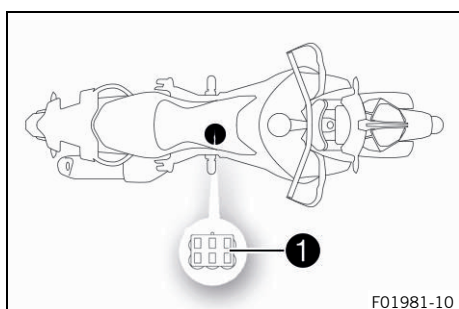

Diagnostics connector **1** is located under the battery cover.

(790 Adventure CN)

At the factory, a diagnostics adapter was plugged in for connection with a diagnostics interface which applies to all manufacturers.

i Info

Unplug the diagnostics adapter to use the KTM diagnostics tool.

Following completion of the diagnosis, plug the diagnostics adapter back in.

2.3 Unpacking and setting up the vehicle

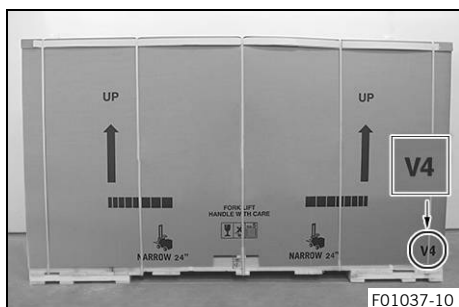

- Remove the straps and box.



- Remove the adhesive tape in the upper area of the motorcycle.



F02126-01

- Roll down the film at the sides.

i Info
To avoid damaging the motorcycle during unpacking, leave the other films on the vehicle until you have finished work on the vehicle.

- Remove the separate enclosure and unpack it. Check the separate enclosure for completeness.

i Info
The procedure in the event of missing components is described in the customer service manual.

- Check the vehicle for transport damage.

i Info
The procedure in the event of transport damage is described in the customer service manual.



F02127-01

- Remove the cable ties. Place the handlebar at the front.
- Remove the clutch and the brake assembly from the transport holder.
- Remove the screws from the handlebar clamps. Take off the handlebar clamps and transport holder.

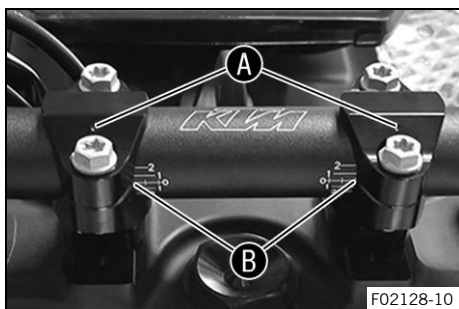

F02128-10

! Warning
Danger of accidents A repaired handlebar poses a safety risk.
If the handlebar is bent or straightened, the material becomes fatigued. The handlebar may break as a result.

- Change the handlebar if the handlebar is damaged or bent.

- Unpack handlebar and position.

i Info
Make sure the cables and wiring are positioned correctly.

- Position the handlebar clamps. Mount and tighten the screws evenly.

Guideline

Screw, handlebar clamp	M8	20 Nm (14.8 lbf ft)
------------------------	----	---------------------

✓ Markings **A** face backward.

- ✓ Handlebar scale markings **B** are located centrally between the handlebar clamps.

i Info
Keep the installed gap widths equal when tightening.

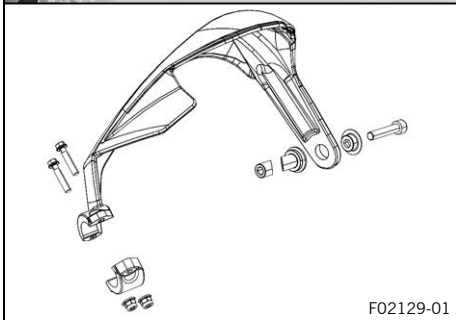

- Mount the right hand guard.

Guideline

Hand guard fitting	M6	6 Nm (4.4 lbf ft)
Hand guard screw	M8	25 Nm (18.4 lbf ft)

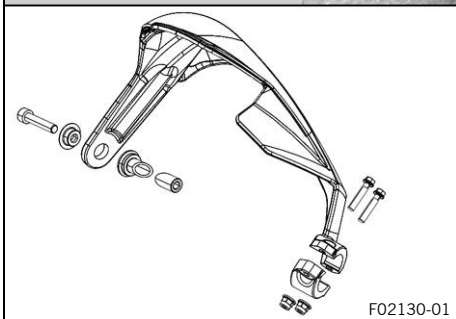
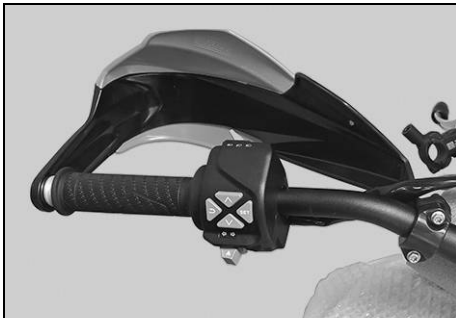

- Mount the left hand guard.

Guideline

Hand guard fitting	M6	6 Nm (4.4 lbf ft)
Hand guard screw	M8	25 Nm (18.4 lbf ft)



- Position the brake assembly on the handlebar.
- Position brake assembly clamp on the handlebar.
- ✓ The holding lug of the clamp engages in the combination switch.
- Mount and tighten screws ①.

Guideline

Screw, brake assembly	M6	5 Nm (3.7 lbf ft)
-----------------------	----	-------------------

- Tighten all the screws on the controls on the right half of the handlebar.

Guideline

Screw for throttle grip	M5	3.5 Nm (2.58 lbf ft)
Screw, combination switch, right	M5	5 Nm (3.7 lbf ft)

i Info

Pay attention to the markings on the handlebar. Make sure the cables and wiring are positioned correctly.

- Tie the cables and wires together with the rubber straps supplied.
- Check the throttle grip for smooth operation.
- Position the clutch assembly on the handlebar.

i Info

Pay attention to the markings on the handlebar.

- Position the clutch assembly clamp on the handlebar.
- Mount and tighten screws ②.

Guideline

Screw, clutch assembly	M6	5 Nm (3.7 lbf ft)
------------------------	----	-------------------

- Tighten all the screws on the controls on the left half of the handlebar.

Guideline

Screw, fixed grip, left	M4	2 Nm (1.5 lbf ft)
Screw, combination switch, left	M5	2 Nm (1.5 lbf ft)

i Info

Pay attention to the markings on the handlebar. Make sure the cables and wiring are positioned correctly.

- Tie the cables and wires together with the rubber straps supplied.

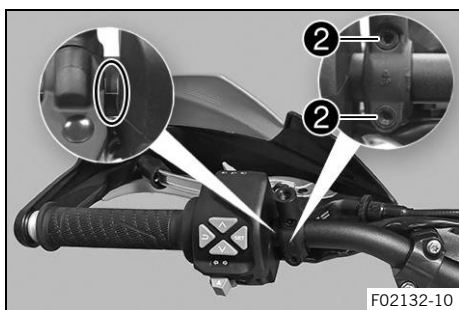

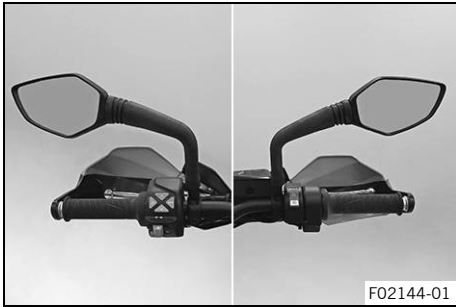

- Mount and tighten the rear mirror on both sides.

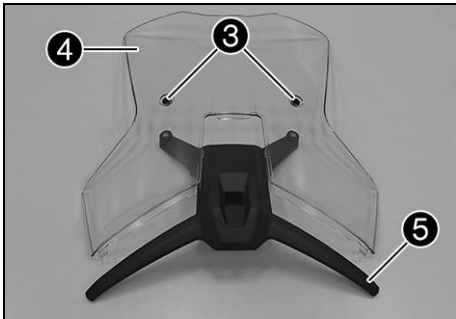

- Mount rubber bushings ③ on windshield ④.
- Mount windshield ④ on windshield bracket ⑤.
- ✓ The windshield engages on the left and right in the recesses of the windshield bracket.

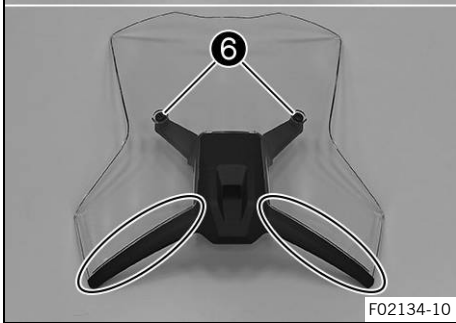

- Mount and tighten screws ⑥.

Guideline

Remaining screws, chassis	M5	5 Nm (3.7 lbf ft)
---------------------------	----	-------------------

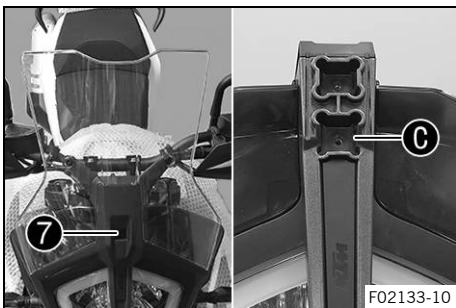

- Position the windshield bracket with the windshield in lower recess ①.
- Mount and tighten screw ⑦.

Guideline

Remaining screws, chassis	M5	5 Nm (3.7 lbf ft)
---------------------------	----	-------------------

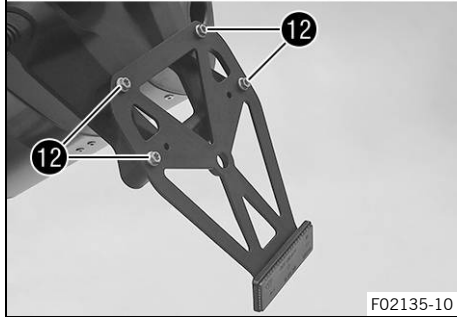
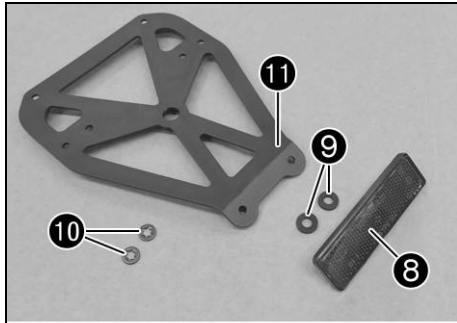

F02135-10

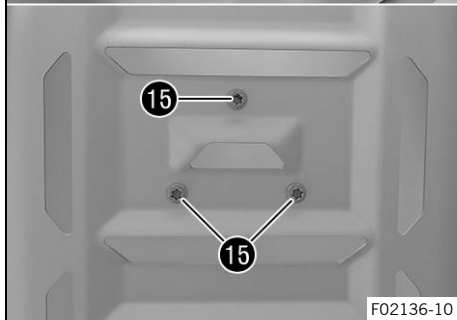
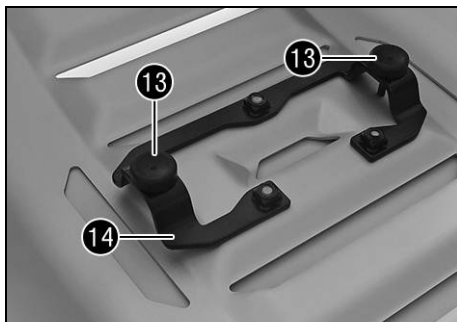

F02136-10

(790 Adventure EU)

- Mount reflector **8** with rubber bushings **9** and tension washers **10** on the license plate holder **11**.
- Position the license plate bracket on the license plate support.
- Mount and tighten screws **12**.

Guideline

Screw, license plate holder	M5	5 Nm (3.7 lbf ft) Loctite®243™
-----------------------------	----	--

- Carefully loosen and remove the rear tension belt.



Info

An assistant prevents the motorcycle from falling over.

- Carefully loosen and remove the tension belts around the lower triple clamp.
- ✓ The vehicle is released at the front.
- Together with an assistant, take the vehicle off the pallet.

- Mount rubber spacers **13** on the retaining bracket **14**.
- Position retaining bracket **14** on the engine guard.
- Mount and tighten screws **15**.

Guideline

Screw, engine guard retaining bracket	M6	10 Nm (7.4 lbf ft) Loctite®243™
---------------------------------------	----	---



- Position the left fuel tank cover.
- Mount and tighten screws 16 with the collar bushings and the absorbing elements.

Guideline

Screw, fuel tank cover	M6x18	5 Nm (3.7 lbf ft) Loctite®243™
------------------------	-------	--

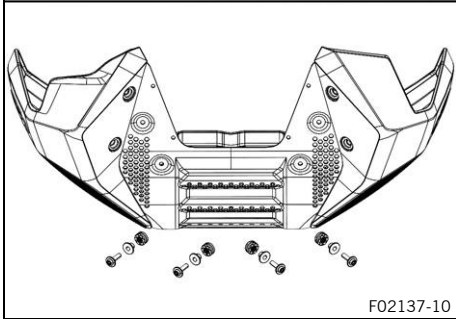

- Position the right fuel tank cover.
- Mount and tighten screws 16 with the collar bushings and the absorbing elements.

Guideline

Screw, fuel tank cover	M6x18	5 Nm (3.7 lbf ft) Loctite®243™
------------------------	-------	--

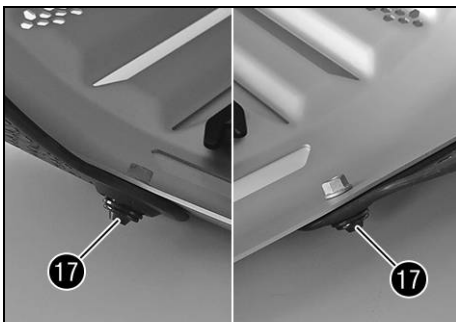

- Mount and tighten fitting 17 with the collar bushings and the absorbing elements.

Guideline

Screw, fuel tank cover	M6	5 Nm (3.7 lbf ft) Loctite®243™
------------------------	----	--

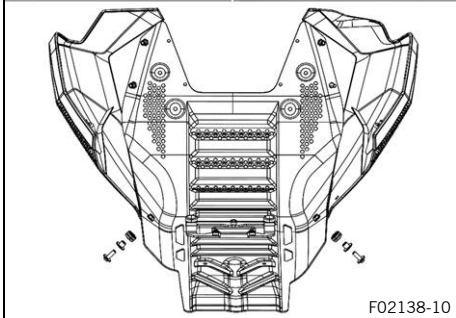

- Position engine guard 18 with the mounted fuel tank covers.
- Mount screws 19, but do not tighten yet.

Guideline

Screw, engine guard	M6x10	10 Nm (7.4 lbf ft) Loctite®243™
---------------------	-------	---

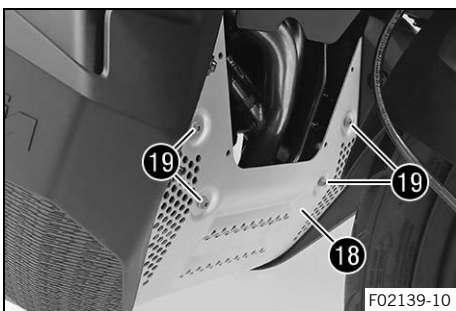

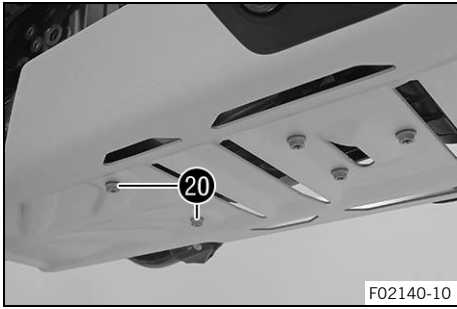

- Mount screws **20**, but do not tighten yet.

Guideline

Screw, engine guard	M6x8	8 Nm (5.9 lbf ft)
---------------------	------	-------------------

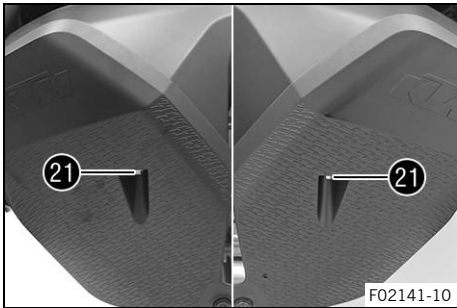

- Mount screws **21**, but do not tighten yet.

Guideline

Screw, fuel tank cover	M6x12	8 Nm (5.9 lbf ft)
------------------------	-------	-------------------

- ✓ The engine guard is directed evenly toward the front.

- Tighten all the screws of the engine guard.

Guideline

Screw, engine guard	M6x8	8 Nm (5.9 lbf ft)
Screw, engine guard	M6x10	10 Nm (7.4 lbf ft) Loctite®243™
Screw, fuel tank cover	M6x12	8 Nm (5.9 lbf ft)



- Mount hose **22** with the angle piece.

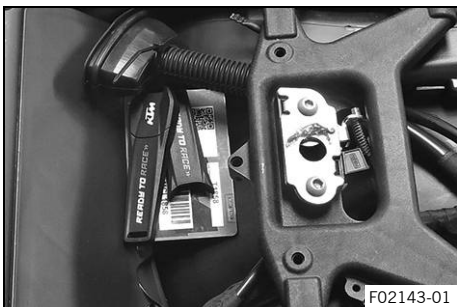

- Remove the front rider's seat. (📖 p. 12)
- Remove spare key and **KEYCODECARD** from under the seat and keep in a safe place for the handover.
- Charge the 12-V battery. (📖 p. 18)

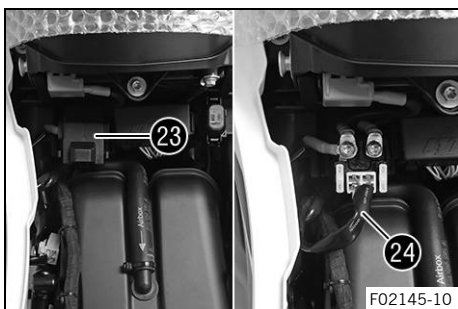

- Remove protection cap 23.
- Plug in the plug 24 of the starter relay.
- Mount protection cap 23.

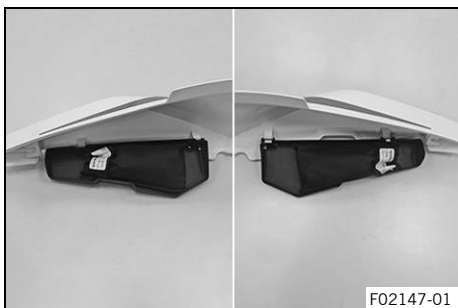

Info

The tool set can be stored in the left or right storage compartment.

The left storage compartment is described as an example.

- Remove the left side cover. (📖 p. 13)
- Open storage compartment on the left. (📖 p. 13)
- Store the tool set in the storage compartment.
- Close storage compartment on the left. (📖 p. 14)
- Install the left side cover. (📖 p. 15)
- Remove the labels from the brake line and the frame.
- Remove the remaining films.
- Check the headlight setting. (📖 p. 21)
- Refuel. (📖 p. 23)
- Prepare the vehicle according to the specifications in the **KTM Dealer.net** for handover to the customer.

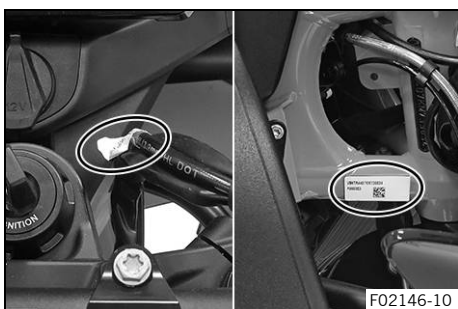

3.1 Removing the passenger seat

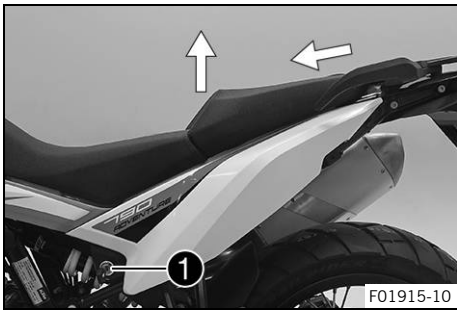

- Insert the ignition key in seat lock ❶ and turn it clockwise.
- Raise the front of the passenger seat, pull it toward the tank, and take off from above.
- Remove the ignition key from the seat lock.

3.2 Mounting the passenger seat

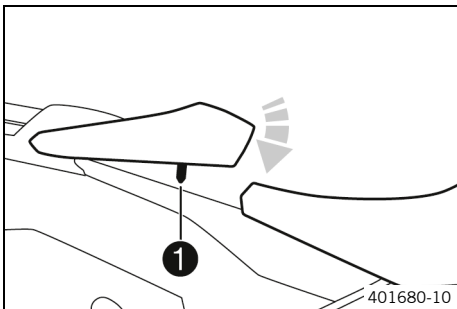

- Hook holding lugs of the passenger seat into the bushings on the subframe, lower the front, and simultaneously push backward.
- Insert locking pin ❶ into the lock housing and push down the front of the passenger seat until the locking pin engages with an audible click.



Warning

Danger of accidents The seat can come loose from the anchoring if it is not mounted correctly.

- After assembly, check whether the seat is correctly locked and cannot be pulled up.

- Finally, check that the passenger seat is correctly mounted.

3.3 Removing the front rider's seat

Preparatory work

- Remove the passenger seat. (📖 p. 12)

Main work

- Lift the rider's seat back and unhook in the ❶ area.

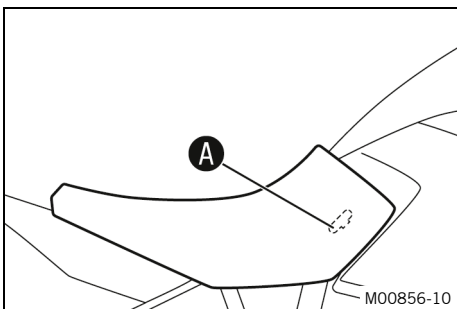

3.4 Mounting the front rider's seat

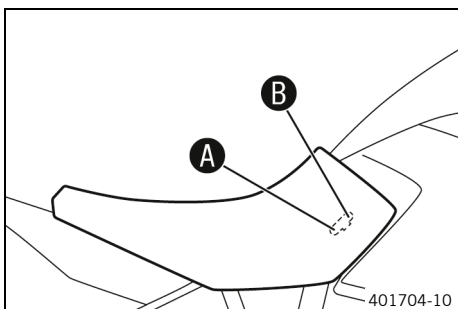

Main work

- Attach the recesses on the front rider's seat to the fuel tank at the desired seat position **A** or **B**, and push the front rider's seat forward while lowering it at the rear.
- Finally, check that the front rider's seat is correctly mounted.

Finishing work

- Mount the passenger seat. (📖 p. 12)



3.5 Removing the left side cover

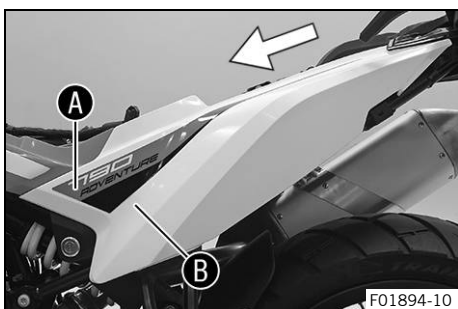

Preparatory work

- Remove the passenger seat. (📖 p. 12)
- Remove the front rider's seat. (📖 p. 12)

Main work

- Remove left side cover from the rubber bushings in the areas **A** and **B**.
- Pull off the left side cover sideways and remove it toward the front.



3.6 Opening the storage compartment on the left

Preparatory work

- Remove the passenger seat. (📖 p. 12)
- Remove the front rider's seat. (📖 p. 12)
- Remove the left side cover. (📖 p. 13)

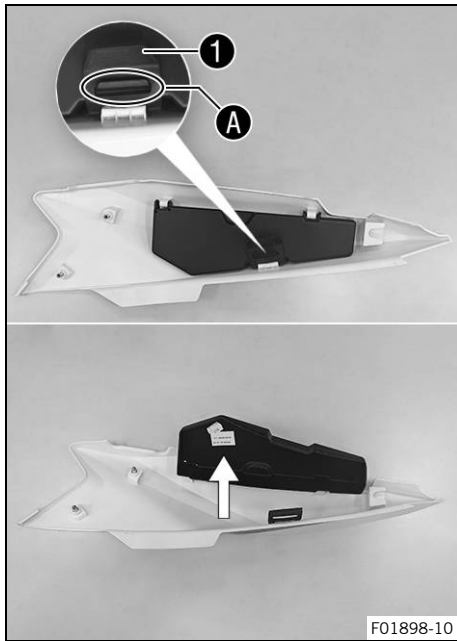

Main work

- Lift the elastic fastener ① and detach in area ①A.
- Open storage compartment.

3.7 Closing the storage compartment on the left

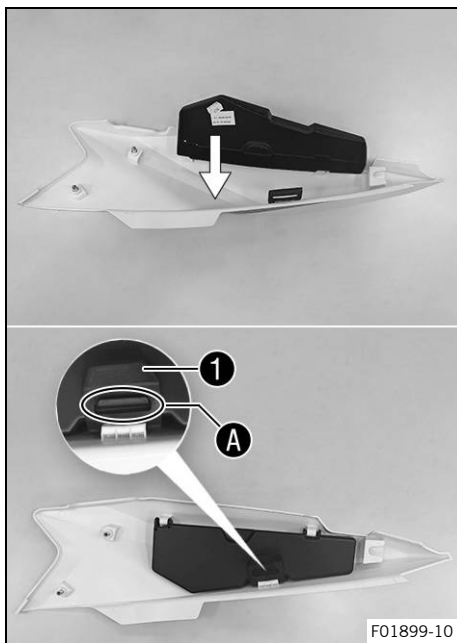

Main work

- Close the storage compartment.
- Raise elastic fastener ① and hang up in area ①A.

Finishing work

- Install the left side cover. (📖 p. 15)
- Mount the front rider's seat. (📖 p. 13)
- Mount the passenger seat. (📖 p. 12)

3.8 Installing the left side cover

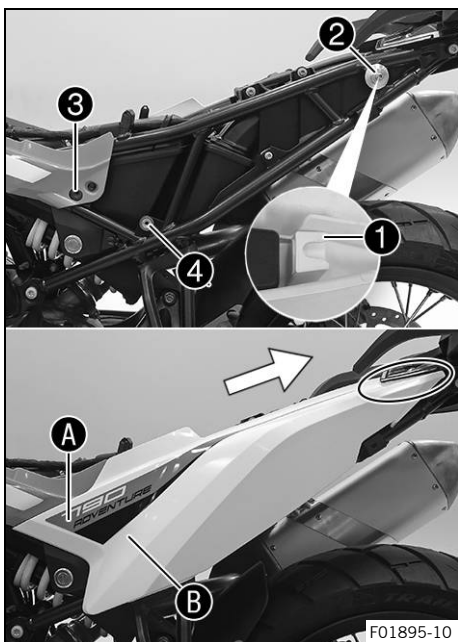

Main work

- Position the left side cover with holding lug 1 on bushing 2 and push backward.
- ✓ The left side cover engages under the tail part.
- Press the left side cover in area A into rubber bushing 3 and press into rubber bushing B in area 4.

Finishing work

- Mount the front rider's seat. (📖 p. 13)
- Mount the passenger seat. (📖 p. 12)

3.9 Removing the right side cover

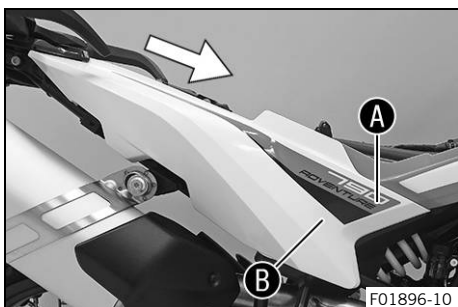

Preparatory work

- Remove the passenger seat. (📖 p. 12)
- Remove the front rider's seat. (📖 p. 12)

Main work

- Remove the side cover from the rubber bushings in areas A and B.
- Pull off the right side cover sideways and remove it toward the front.

3.10 Opening the storage compartment on the right

Preparatory work

- Remove the passenger seat. (📖 p. 12)
- Remove the front rider's seat. (📖 p. 12)
- Remove the right side cover. (📖 p. 15)

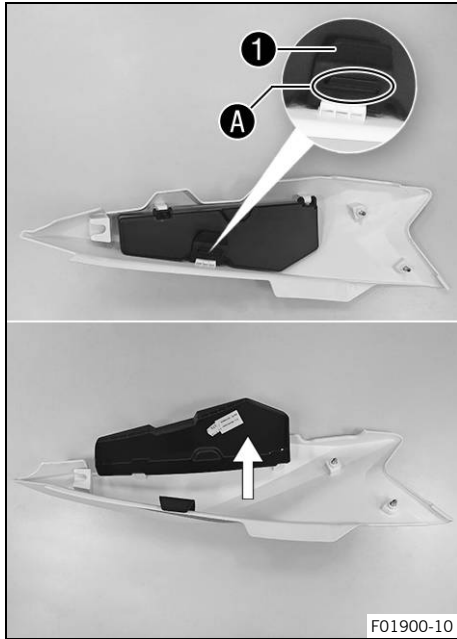

Main work

- Lift the elastic fastener **1** and detach in area **A**.
- Open storage compartment.

3.11 Closing the storage compartment on the right

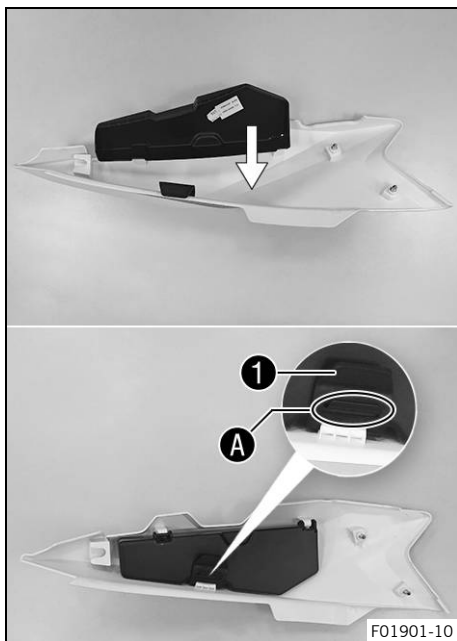

Main work

- Close the storage compartment.
- Raise elastic fastener **1** and hang up in area **A**.

Finishing work

- Install the right side cover. (📖 p. 17)
- Mount the front rider's seat. (📖 p. 13)
- Mount the passenger seat. (📖 p. 12)

3.12 Installing the right side cover

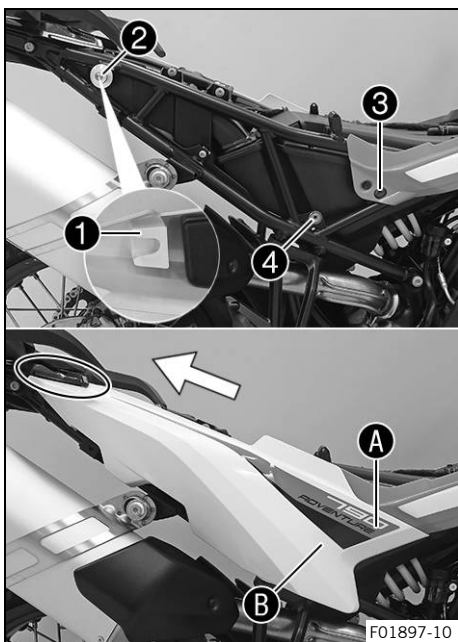

Main work

- Position the right side cover with holding lug ① on bushing ② and push backward.
- ✓ The right side cover engages under the tail part.
- Press the right side cover in the area A into rubber bushing ③ and press into rubber bushing B in area ④.

Finishing work

- Mount the front rider's seat. (📖 p. 13)
- Mount the passenger seat. (📖 p. 12)



3.13 Removing the battery cover

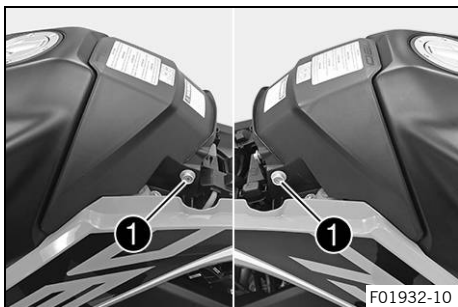

Preparatory work

- Remove the passenger seat. (📖 p. 12)
- Remove the front rider's seat. (📖 p. 12)

Main work

- Remove screws ① with the bushings.
- Remove the battery cover from above.

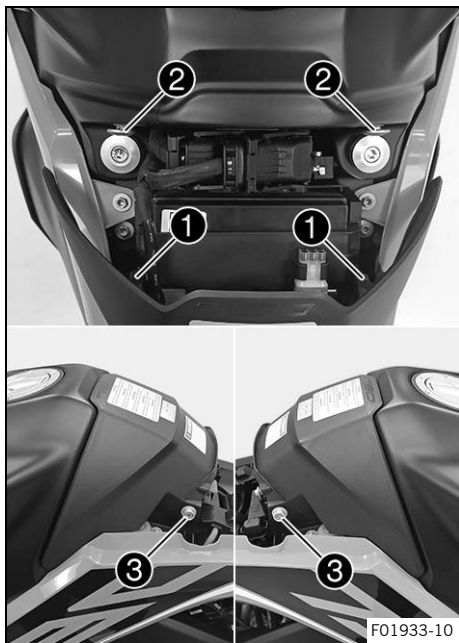

3.14 Installing the battery cover

**Main work**

- Position the battery cover with holding lugs **1** on bushings **2** and push downward.
- ✓ The battery cover engages on the left and right under the fuel tank spoiler.
- Mount screws **3** with the bushings and tighten.

Guideline

Screw, seat fixing	M6	5 Nm (3.7 lbf ft)
--------------------	----	-------------------

Finishing work

- Mount the front rider's seat. (📖 p. 13)
- Mount the passenger seat. (📖 p. 12)

3.15 Charging the 12-V battery

**Warning**

Risk of injury Battery acid and battery gases cause serious chemical burns.

- Keep 12 V batteries out of the reach of children.
- Wear suitable protective clothing and safety glasses.
- Avoid contact with battery acid and battery gases.
- Keep sparks or open flames away from the 12 V battery.
- Only charge 12 V batteries in well-ventilated rooms.
- Rinse the affected area immediately with plenty of water in the event of contact with the skin.
- Rinse eyes with water for at least 15 minutes and consult a doctor immediately if battery acid and battery gases get into the eyes.

**Note**

Environmental hazard 12 V batteries contain environmentally hazardous materials.

- Do not dispose of 12 V batteries as household waste.
- Dispose of 12 V batteries at a collection point for used batteries.

**Note**

Environmental hazard Hazardous substances cause environmental damage.

- Dispose of oils, grease, filters, fuel, cleaning agents, brake fluid, etc., correctly and in compliance with the applicable regulations.

i Info

Even if there is no load on the 12-V battery, it discharges steadily each day. The charging level and the method of charging are very important for the service life of the 12-V battery. Rapid recharging with a high charging current shortens the service life of the battery. If the charging current, charging voltage, and charging time are exceeded, the 12-V battery will be destroyed. If the 12-V battery is depleted from starting the vehicle repeatedly, the battery must be charged immediately. If the 12-V battery is left in a discharged state for an extended period, it will become deeply discharged and sulfating occurs, destroying the battery. The 12-V battery is maintenance-free, i.e. the acid level does not have to be checked.

Preparatory work

- Switch off the ignition by turning the ignition key to the position \otimes .
- Remove the passenger seat. (📖 p. 12)
- Remove the front rider's seat. (📖 p. 12)
- Disconnect the negative cable of the 12-V battery. (📖 p. 20)

Main work

- Connect the battery charger to the 12-V battery. Adjust the battery charger.

EU battery charger **XCharge-professional** (00029095050)

Alternative 1

US battery charger **XCharge-professional** (00029095051)

Alternative 2

UK battery charger **XCharge-professional** (00029095052)

Alternative 3

CH battery charger **XCharge-professional** (00029095053)

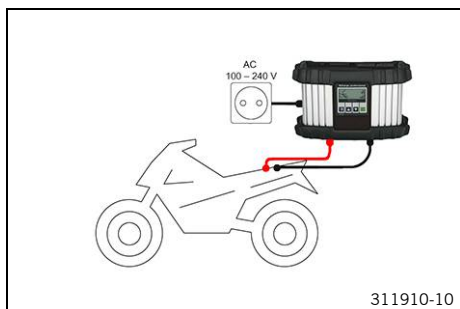

i Info

Follow the instructions of the charger and the manual.

- Disconnect the battery charger after charging the 12-V battery.
- Guideline

The charging current, charging voltage, and charging time must not be exceeded.

Recharge the 12-V battery regularly when the motorcycle is not being used	3 months
---	----------

Finishing work

- Connect the negative cable of the 12-V battery. (📖 p. 20)
- Mount the front rider's seat. (📖 p. 13)
- Mount the passenger seat. (📖 p. 12)
- Set the time and date.

3.16 Disconnecting the negative cable of the 12-V battery



Warning

Risk of injury Battery acid and battery gases cause serious chemical burns.

- Keep 12 V batteries out of the reach of children.
- Wear suitable protective clothing and safety glasses.
- Avoid contact with battery acid and battery gases.
- Keep sparks or open flames away from the 12 V battery.
- Only charge 12 V batteries in well-ventilated rooms.
- Rinse the affected area immediately with plenty of water in the event of contact with the skin.
- Rinse eyes with water for at least 15 minutes and consult a doctor immediately if battery acid and battery gases get into the eyes.



Caution

Danger of accidents Electronic components and safety devices will be damaged if the 12-V battery is discharged or missing.

- Never operate the vehicle with a discharged 12-V battery or without a 12-V battery.

Preparatory work

- Switch off the ignition by turning the ignition key to the position \otimes .
- Remove the passenger seat. (📖 p. 12)
- Remove the front rider's seat. (📖 p. 12)

Main work

- Disconnect negative cable ① from the 12-V battery.



3.17 Connecting the negative cable of the 12-V battery



Warning

Risk of injury Battery acid and battery gases cause serious chemical burns.

- Keep 12 V batteries out of the reach of children.
- Wear suitable protective clothing and safety glasses.
- Avoid contact with battery acid and battery gases.
- Keep sparks or open flames away from the 12 V battery.
- Only charge 12 V batteries in well-ventilated rooms.
- Rinse the affected area immediately with plenty of water in the event of contact with the skin.
- Rinse eyes with water for at least 15 minutes and consult a doctor immediately if battery acid and battery gases get into the eyes.



Caution

Danger of accidents Electronic components and safety devices will be damaged if the 12-V battery is discharged or missing.

- Never operate the vehicle with a discharged 12-V battery or without a 12-V battery.

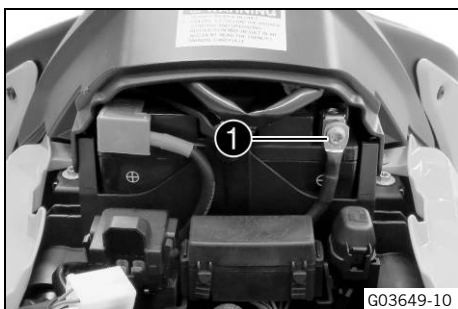

G03649-10

Main work

- Connect negative cable ① to the 12-V battery.

Guideline

Screw, battery terminal	M6	4.5 Nm (3.32 lbf ft)
-------------------------	----	-------------------------

Finishing work

- Mount the front rider's seat. (📖 p. 13)
- Mount the passenger seat. (📖 p. 12)
- Set the time and date.



3.18 Checking the headlight setting

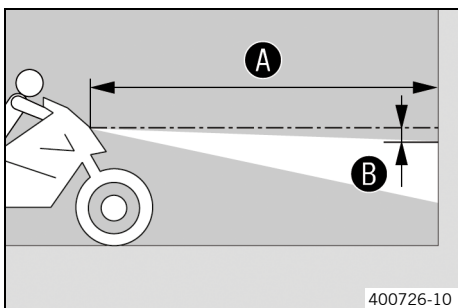

400726-10

- Park the vehicle on a horizontal surface in front of a light-colored wall and make a mark at the height of the center of the low beam headlight.

- Make another mark at a distance ② under the first marking.

Guideline

Distance ②	5 cm (2 in)
------------	-------------

- Position the vehicle upright at distance ① from the wall and switch on the low beam.

Guideline

Distance ①	5 m (16 ft)
------------	-------------

- The rider now mounts the motorcycle with luggage and passenger if applicable.
- Check the headlight setting.

The light-dark boundary must be exactly on the lower marking when the motorcycle is ready to be operated with the rider mounted along with any luggage and a passenger if applicable.

- » If the boundary between light and dark does not meet specifications:
 - Adjust headlight range. (📖 p. 22)



3.19 Adjusting the headlight range

Preparatory work

- Check the headlight setting. (📖 p. 21)

Main work

- Remove screws ❶.
- Remove the left mask spoiler.

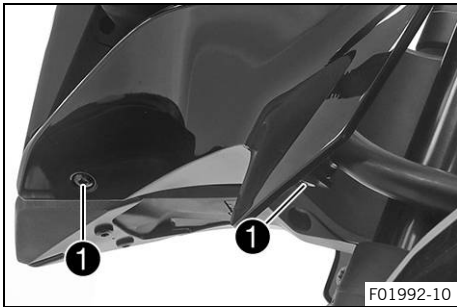

- Turn adjusting screw ❷ to adjust the headlight range.

i Info

Turn clockwise to reduce the headlight range; turn counterclockwise to increase the headlight range. If you have a payload, you may have to correct the headlight range.

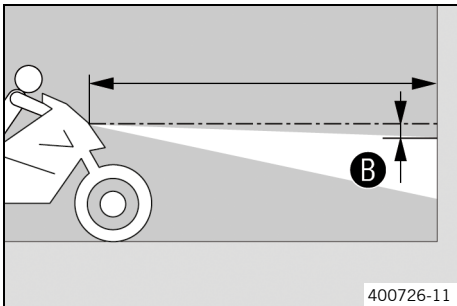

- Set the headlight to marking ❷.

Guideline

The light-dark boundary must lie exactly on lower marking ❷ when the motorcycle is ready to operate with the rider mounted along with any luggage and a passenger, if applicable.

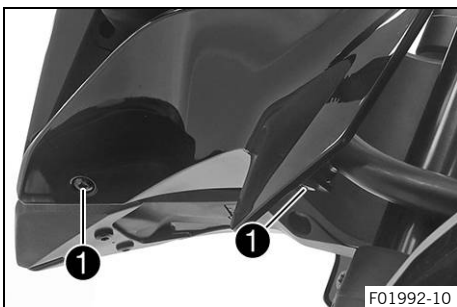

- Position left mask spoiler.
- Mount and tighten screws ❶.

Guideline

Remaining screws, chassis	M5	5 Nm (3.7 lbf ft)
---------------------------	----	-------------------

3.20 Refueling



Danger

Fire hazard Fuel is highly flammable.

The fuel in the fuel tank expands when warm and can escape if overfilled.

- Do not refuel the vehicle in the vicinity of open flames or lit cigarettes.
- Switch off the engine for refueling.
- Make sure that no fuel is spilled; particularly not on hot parts of the vehicle.
- If any fuel is spilled, wipe it off immediately.
- Observe the specifications for refueling.



Warning

Danger of poisoning Fuel is poisonous and a health hazard.

- Avoid skin, eye and clothing contact with fuel.
- Immediately consult a doctor if you swallow fuel.
- Do not inhale fuel vapors.
- In case of skin contact, rinse the affected area with plenty of water.
- Rinse the eyes thoroughly with water, and consult a doctor in case of fuel contact with the eyes.
- Change your clothing in case of fuel spills on them.

Note

Material damage Inadequate fuel quality causes the fuel filter to quickly become clogged.

In some countries and regions, the available fuel quality and cleanliness may not be sufficient. This will result in problems with the fuel system.

- Refuel only with clean fuel that meets the specified standards.



Note

Environmental hazard Improper handling of fuel is a danger to the environment.

- Do not allow fuel to enter the groundwater, the soil, or the sewage system.



- Switch off the engine.
- Open the fuel tank filler cap. (📖 p. 24)
- Fill the fuel tank with fuel up to the lower edge **A** of the filler neck.

Total fuel tank capacity, approx.	20 l (5.3 US gal)	Super unleaded (ROZ 95/RON 95/PON 91) (📖 p. 30)
-----------------------------------	----------------------	---



Info

An optional flash file allows lower quality fuel to be used. Further information, for example relating to octane number, is available from an authorized KTM dealer.

- Close the fuel tank filler cap. (📖 p. 24)



F01912-10

3.21 Opening the fuel tank filler cap



Danger

Fire hazard Fuel is highly flammable.

The fuel in the fuel tank expands when warm and can escape if overfilled.

- Do not refuel the vehicle in the vicinity of open flames or lit cigarettes.
- Switch off the engine for refueling.
- Make sure that no fuel is spilled; particularly not on hot parts of the vehicle.
- If any fuel is spilled, wipe it off immediately.
- Observe the specifications for refueling.



Warning

Danger of poisoning Fuel is poisonous and a health hazard.

- Avoid skin, eye and clothing contact with fuel.
- Immediately consult a doctor if you swallow fuel.
- Do not inhale fuel vapors.
- In case of skin contact, rinse the affected area with plenty of water.
- Rinse the eyes thoroughly with water, and consult a doctor in case of fuel contact with the eyes.
- Change your clothing in case of fuel spills on them.
- Keep fuels correctly in a suitable canister, and out of the reach of children.



Note

Environmental hazard Improper handling of fuel is a danger to the environment.

- Do not allow fuel to enter the groundwater, the soil, or the sewage system.

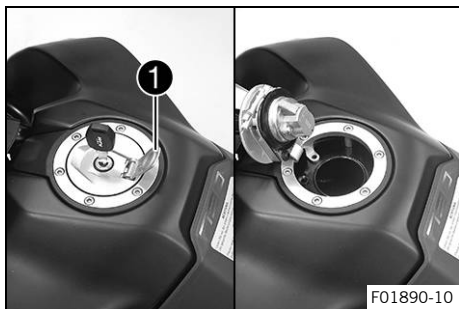

- Lift cover **1** of the fuel tank filler cap and insert the ignition key into the lock.

Note

Danger of damage The ignition key may break if overloaded. Damaged ignition keys must be replaced.

- Push down on the fuel tank filler cap to take pressure off the ignition key.
- Turn the ignition key 90° clockwise.
- Lift the fuel tank filler cap.

3.22 Closing the fuel tank filler cap



- Fold down the fuel tank filler cap.
- Turn the ignition key 90° clockwise.
- Push down the fuel tank filler cap and turn the ignition key counterclockwise until the lock closes.

**Warning**

Fire hazard Fuel is highly flammable, toxic and a health hazard.

- Check that the fuel tank filler cap is locked correctly after closing.
- Change your clothing if fuel spills on them.
- Rinse the affected area immediately with plenty of water in the event of contact with the skin.

- Remove the ignition key and close the cover.



4 TECHNICAL DATA

4.1 Chassis tightening torques

Nut, valve	ISO 10V2	12 Nm (8.9 lbf ft) Loctite®2701™
Remaining screws, chassis	EJOTPT® K45x12	1 Nm (0.7 lbf ft)
Remaining screws, chassis	EJOTPT® K50x12	1 Nm (0.7 lbf ft)
Remaining screws, chassis	EJOTPT® K50x14	1 Nm (0.7 lbf ft)
Remaining screws, chassis	EJOTPT® K50x16	2 Nm (1.5 lbf ft)
Remaining screws, chassis	EJOTPT® K50x18	2 Nm (1.5 lbf ft)
Screw, tail light	EJOT DELTA PT® 45x12-Z	1.5 Nm (1.11 lbf ft)
Remaining nuts, chassis	M4	3 Nm (2.2 lbf ft)
Remaining screws, chassis	M4	3 Nm (2.2 lbf ft)
Screw, fixed grip, left	M4	2 Nm (1.5 lbf ft)
Remaining nuts, chassis	M5	5 Nm (3.7 lbf ft)
Remaining screws, chassis	M5	5 Nm (3.7 lbf ft)
Screw for throttle grip	M5	3.5 Nm (2.58 lbf ft)
Screw, air filter box	M5	3 Nm (2.2 lbf ft)
Screw, brake fluid reservoir for rear brake	M5	5 Nm (3.7 lbf ft) Loctite®243™
Screw, brake line holder on link fork	M5	1 Nm (0.7 lbf ft)
Screw, cable on starter motor	M5	3 Nm (2.2 lbf ft)
Screw, combination instrument	M5	4 Nm (3 lbf ft)
Screw, combination switch, left	M5	2 Nm (1.5 lbf ft)
Screw, combination switch, right	M5	5 Nm (3.7 lbf ft)
Screw, engine sprocket cover	M5	5 Nm (3.7 lbf ft) Loctite®243™
Screw, fender	M5x12	5 Nm (3.7 lbf ft)
Screw, fender	M5x17	5 Nm (3.7 lbf ft)
Screw, foot brake lever stub	M5	5 Nm (3.7 lbf ft) Loctite®243™
Screw, heat guard	M5	5 Nm (3.7 lbf ft) Loctite®243™
Screw, license plate holder	M5	5 Nm (3.7 lbf ft) Loctite®243™
Screw, lower rear panel	M5	3 Nm (2.2 lbf ft)
Screw, side stand sensor	M5	2 Nm (1.5 lbf ft) Loctite®243™
Screw, trim	M5	3 Nm (2.2 lbf ft)
Nut, hand brake lever	M6	Attach torque to nut. 10 Nm (7.4 lbf ft)
Nut, push rod, foot brake lever	M6	6 Nm (4.4 lbf ft)
Nut, shift rod	M6	6 Nm (4.4 lbf ft)
Nut, shift rod	M6LH	6 Nm (4.4 lbf ft)
Remaining nuts, chassis	M6	10 Nm (7.4 lbf ft)
Remaining screws, chassis	M6	10 Nm (7.4 lbf ft)
Screw, angle sensor	M6	5 Nm (3.7 lbf ft)
Screw, battery cover attachment	M6	3 Nm (2.2 lbf ft)

Screw, battery support bracket	M6	4.5 Nm (3.32 lbf ft)	
Screw, battery terminal	M6	4.5 Nm (3.32 lbf ft)	
Screw, brake assembly	M6	5 Nm (3.7 lbf ft)	
Screw, clutch assembly	M6	5 Nm (3.7 lbf ft)	
Screw, cross member in rear	M6x13	10 Nm (7.4 lbf ft)	Loctite®243™
Screw, cross member in rear	M6x12	6 Nm (4.4 lbf ft)	Loctite®243™
Screw, engine guard	M6x8	8 Nm (5.9 lbf ft)	
Screw, engine guard	M6x10	10 Nm (7.4 lbf ft)	Loctite®243™
Screw, foot brake cylinder	M6	10 Nm (7.4 lbf ft)	Loctite®243™
Screw, footrest bracket, rear	M6	6 Nm (4.4 lbf ft)	Loctite®243™
Screw, front brake disc	M6	14 Nm (10.3 lbf ft)	Loctite®243™
Screw, front wheel speed sensor	M6	6 Nm (4.4 lbf ft)	
Screw, fuel tank cover	M6x12	8 Nm (5.9 lbf ft)	
Screw, fuel tank cover	M6x18	5 Nm (3.7 lbf ft)	Loctite®243™
Screw, fuel tank cover	M6	5 Nm (3.7 lbf ft)	Loctite®243™
Screw, fuel tank spoiler	M6	5 Nm (3.7 lbf ft)	
Screw, fuel tank spoiler attachment	M6	3 Nm (2.2 lbf ft)	
Screw, ground wire on frame	M6	6 Nm (4.4 lbf ft)	
Screw, ground wire to starter motor	M6	10 Nm (7.4 lbf ft)	
Screw, headlight mask	M6	10 Nm (7.4 lbf ft)	Loctite®243™
Screw, ignition lock (tamper-proof screw)	M6	Tighten until the head tears off.	Loctite®243™
Screw, magnetic holder on side stand	M6	2 Nm (1.5 lbf ft)	Loctite®243™
Screw, manifold clamp	M6	8 Nm (5.9 lbf ft)	Copper paste
Screw, radiator bracket, bottom	M6	5 Nm (3.7 lbf ft)	
Screw, rear brake disc	M6	14 Nm (10.3 lbf ft)	Loctite®243™
Screw, rear wheel speed sensor	M6	6 Nm (4.4 lbf ft)	
Screw, seat fixing	M6	5 Nm (3.7 lbf ft)	
Screw, seat lock	M6	10 Nm (7.4 lbf ft)	Loctite® 222™
Screw, shift rod	M6	10 Nm (7.4 lbf ft)	Loctite®243™
Screw, shift shaft deflector on shift shaft	M6	10 Nm (7.4 lbf ft)	Loctite®243™
Foot brake lever, fitting	M8	25 Nm (18.4 lbf ft)	Loctite®2701™

4 TECHNICAL DATA

Nut, manifold on cylinder head	M8	Tighten the nuts evenly. Do not bend the metal. 20 Nm (14.8 lbf ft) Copper paste
Nut, rear sprocket screw	M8	35 Nm (25.8 lbf ft) Loctite®243™
Pin, rear brake caliper	M8	22 Nm (16.2 lbf ft) Loctite®243™
Remaining nuts, chassis	M8	25 Nm (18.4 lbf ft)
Remaining screws, chassis	M8	25 Nm (18.4 lbf ft)
Screw, bottom triple clamp	M8	12 Nm (8.9 lbf ft)
Screw, engine fixing arm linkage bracket	M8	25 Nm (18.4 lbf ft) Loctite®243™
Screw, engine guard frame	M8	25 Nm (18.4 lbf ft) Loctite®243™
Screw, foot brake lever spring	M8	10 Nm (7.4 lbf ft) Loctite®2701™
Screw, fork stub	M8	15 Nm (11.1 lbf ft)
Screw, grab handle	M8	25 Nm (18.4 lbf ft) Loctite®243™
Screw, handlebar clamp	M8	20 Nm (14.8 lbf ft)
Screw, main silencer fastening	M8	15 Nm (11.1 lbf ft)
Screw, passenger seat bracket	M8	25 Nm (18.4 lbf ft) Loctite®243™
Screw, presilencer on frame	M8	25 Nm (18.4 lbf ft) Loctite®243™
Screw, rear footrest bracket	M8	25 Nm (18.4 lbf ft) Loctite®243™
Screw, shift lever	M8	25 Nm (18.4 lbf ft) Loctite®2701™
Screw, spring holder plate on side stand bracket	M8	15 Nm (11.1 lbf ft) Loctite®2701™
Screw, steering damper on holder	M8	8 Nm (5.9 lbf ft) Loctite®243™
Screw, steering damper on triple clamp	M8	8 Nm (5.9 lbf ft) Loctite®243™
Screw, steering stem	M8	20 Nm (14.8 lbf ft) Loctite®243™
Screw, subframe	M8	25 Nm (18.4 lbf ft) Loctite®243™
Screw, top triple clamp	M8	15 Nm (11.1 lbf ft)
Securing bolt for brake linings	M8	10 Nm (7.4 lbf ft)
Remaining nuts, chassis	M10	45 Nm (33.2 lbf ft)
Remaining screws, chassis	M10	45 Nm (33.2 lbf ft)
Screw, engine bracket	M10	45 Nm (33.2 lbf ft) Loctite®243™
Screw, front footrest bracket	M10x30	45 Nm (33.2 lbf ft) Loctite®243™
Screw, front footrest bracket	M10x40	45 Nm (33.2 lbf ft) Loctite®243™

Screw, front footrest bracket	M10x65	45 Nm (33.2 lbf ft) Loctite®243™
Screw, handlebar support	M10	45 Nm (33.2 lbf ft) Loctite®243™
Screw, side stand	M10	40 Nm (29.5 lbf ft) Loctite®243™
Screw, subframe	M10	50 Nm (36.9 lbf ft) Loctite®243™
Banjo bolt, brake line	M10x1	25 Nm (18.4 lbf ft)
Screw, front brake caliper	M10x1.25	45 Nm (33.2 lbf ft) Loctite®243™
Screw, bottom shock absorber	M12	80 Nm (59 lbf ft) Loctite®2701™
Screw, swingarm pivot	M12	100 Nm (73.8 lbf ft)
Screw, top shock absorber	M12	80 Nm (59 lbf ft) Loctite®2701™
Lambda sensor	M18x1.5	50 Nm (36.9 lbf ft)
Adjusting screw, swingarm	M20LHx1.5	10 Nm (7.4 lbf ft)
Nut, rear wheel spindle	M25x1.5	90 Nm (66.4 lbf ft) Thread and contact area of wheel spindle greased
Screw, front wheel spindle	M25x1.5	45 Nm (33.2 lbf ft) Thread greased
Screw, steering head	M25x1.5	18 Nm (13.3 lbf ft)

Super unleaded (ROZ 95/RON 95/PON 91)

Standard/classification

- DIN EN 228 (ROZ 95/RON 95/PON 91)

Guideline

- Only use unleaded super fuel that matches or is equivalent to the specified fuel grade.
- Fuel with an ethanol content of up to 10 % (E10 fuel) is safe to use.



Info

Do **not** use fuel containing methanol (e. g. M15, M85, M100) or more than 10 % ethanol (e. g. E15, E25, E85, E100).

READY TO RACE

>> www.ktm.com



3214165en

10/2019



KTM

KTM Sportmotorcycle GmbH
5230 Mattighofen/Austria
<http://www.ktm.com>



Photo: Mitterbauer/KISKA/KTM