

890 Duke R

Art. no. 3214444en



KTM

Perform the work described in these setup instructions before the vehicle is delivered to the customer.

Read the setup instructions in their entirety before beginning work.

These setup instructions were written to correspond to the latest state of this series. We reserve the right to make changes in the interest of technical advancement without at the same time updating this manual. We shall not provide a description of general workshop methods. Likewise, safety rules that apply in a workshop are not specified here. It is assumed that the work will be performed by a fully trained mechanic.

All specifications contained herein are non-binding. KTM Sportmotorcycle GmbH specifically reserves the right to modify or delete technical specifications, prices, colors, forms, materials, services, designs, equipment, etc., without prior notice and without specifying reasons, to adapt these to local conditions, as well as to stop production of a particular model without prior notice. KTM accepts no liability for delivery options, deviations from figures and descriptions, misprints, and other errors. The models portrayed partly contain special equipment that does not belong to the regular scope of supply.

© 2021 KTM Sportmotorcycle GmbH, Mattighofen Austria

All rights reserved

Reproduction, even in part, as well as copying of all kinds, is permitted only with the express written permission of the copyright owner.



ISO 9001(12 100 6061)

KTM applies quality assurance processes that lead to the highest possible product quality as defined in the ISO 9001 international quality management standard.

Issued by: TÜV Management Service

REG.NO. 12 100 6061

KTM Sportmotorcycle GmbH
Stallhofnerstraße 3
5230 Mattighofen, Austria

This document is valid for the following models:

890 Duke R EU (F9703T3, F9703T5)

890 Duke R US (F9775T3)



1 MEANS OF REPRESENTATION

1.1 Symbols used

The meaning of specific symbols is described below.



Indicates an expected reaction (e.g. of a work step or a function).



Indicates an unexpected reaction (e.g. of a work step or a function).



Indicates a page reference (more information is provided on the specified page).



Indicates information with more details or tips.



Indicates the result of a testing step.



Indicates a voltage measurement.



Indicates a current measurement.



Indicates a resistance measurement.



Indicates the end of an activity including potential rework.

1.2 Formats used

The typographical formats used in this document are explained below.

Proprietary name

Indicates a proprietary name.

Name®

Indicates a protected name.

Brand™

Indicates a brand available on the open market.

Underlined terms

Refer to technical details of the vehicle or indicate technical terms, which are explained in the glossary.

2.1 Transport mode

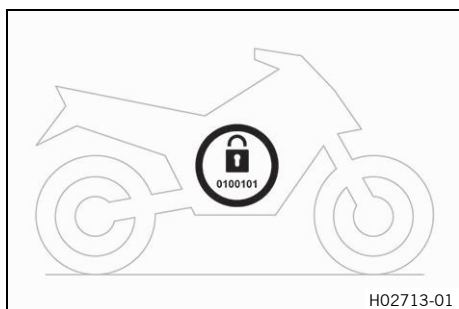

This vehicle was blocked for transport in the software. To operate the vehicle, the vehicle electronics must be enabled. This process is conducted during initial setup in KTM Dealer.net. Enabling ensures that the initial setup in KTM Dealer.net is documented. Enabling can be performed either temporarily, e.g. for a test ride, or permanently for vehicle handover.

i Info
Make sure that the vehicle is permanently enabled before handing it over to the customer.

2.2 Diagnostics connector

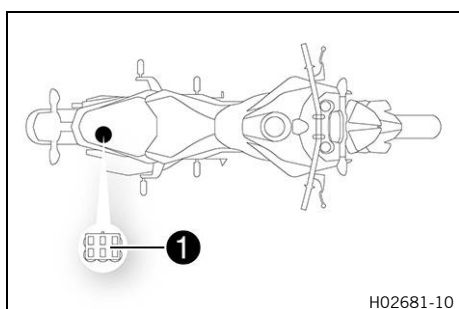

Diagnostics connector **1** is located under the passenger seat.

2.3 Unpacking and setting up the vehicle

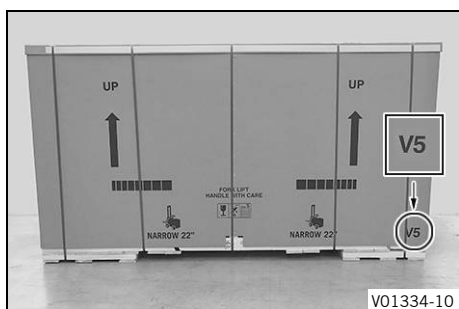

- Remove the straps and the box.



- Remove the adhesive tape in the upper area of the motorcycle.
- Roll down the film at the sides.

Guideline

To avoid damaging the vehicle while setting it up, do not remove the protective film on each component until installing the component, and leave it on the vehicle until work has been completed.

- Remove the separate enclosure and unpack it. Check that the scope of supply is complete using the enclosed packing list.

i Info
The procedure for missing components is described in the Customer Service Manual.

- Check the vehicle for transport damage.

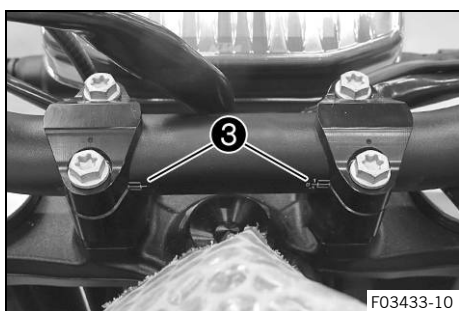
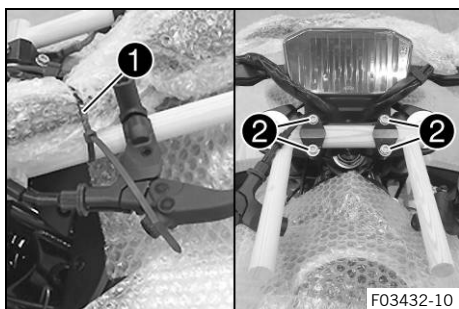

i Info

The procedure in the event of transport damage is described in the Customer Service Manual.

- Remove cable tie(s) ①. Place the handlebar at the front.
- Remove the clutch and the brake assembly from the transport holder.
- Remove screws ② from the handlebar clamps. Take off the handlebar clamps and transport holder.



Warning

Danger of accidents A repaired handlebar poses a safety risk.

If the handlebar is bent or straightened, the material becomes fatigued. The handlebar may break as a result.

- Change the handlebar if the handlebar is damaged or bent.

- Unpack handlebar and position.

i Info

Make sure the cables and wiring are positioned correctly.

The markings ③ on the handlebar should be at the height of the gap between the handlebar supports and the handlebar clamps.

- Position the handlebar clamps. Mount and tighten the screws evenly.

Guideline

Screw, handlebar clamp	M8	20 Nm (14.8 lbf ft)
------------------------	----	---------------------

i Info

Keep the installed gap widths equal when tightening.

- Check the handlebar position.
 - » If the handlebar position is not adjusted as required by the customer:
 - Adjust the handlebar position. (📖 p. 12)

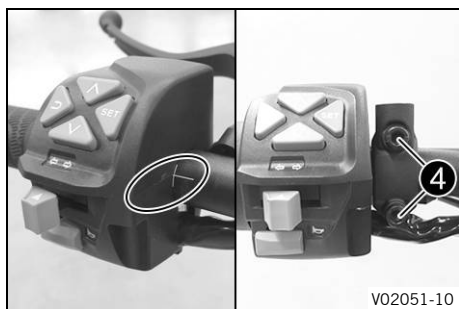

V02051-10

- Align the controls of the left handlebar half with the markings on the handlebar. Tighten the screws.

Guideline

Screw, combination switch, left	M5	2 Nm (1.5 lbf ft)
---------------------------------	----	-------------------

- Position the clutch assembly on the handlebar.
- Position the clutch assembly clamp on the handlebar.
- Mount and tighten screws **4**.

Guideline

Remaining screws, chassis	M6	10 Nm (7.4 lbf ft)
---------------------------	----	--------------------

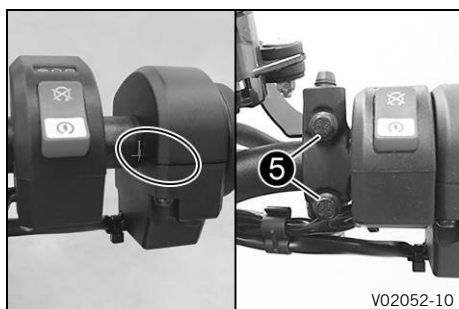

V02052-10

- Align the control of the right handlebar half with the markings on the handlebar. Tighten the screws.

Guideline

Screw, throttle grip	M5	3.5 Nm (2.58 lbf ft)
Screw, combination switch, right	M5	5 Nm (3.7 lbf ft)

- Check the throttle grip for smooth operation.
- Position the brake assembly on the handlebar.
- Position brake assembly clamp on the handlebar.
 - ✓ The holding lug of the clamp engages in the combination switch.
- Mount and tighten screws **5**.

Guideline

Remaining screws, chassis	M6	10 Nm (7.4 lbf ft)
---------------------------	----	--------------------

- Tie the cables together with the rubber straps supplied.
- Mount and tighten the rear mirror on both sides.

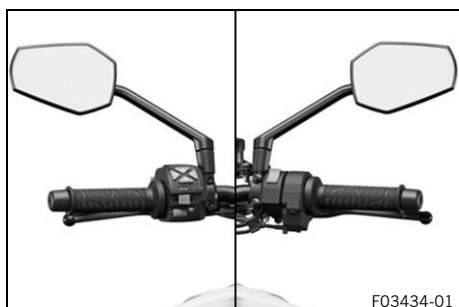

F03434-01

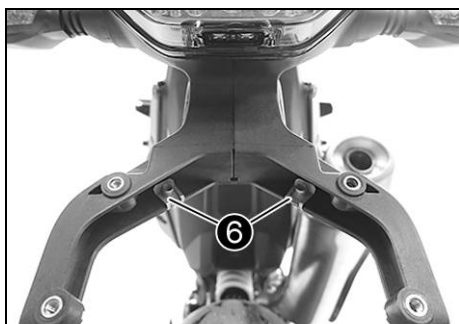

- Mount speed nuts **6** on the license plate support.
- Position the splash protector.
- Mount and tighten screws **7**.

Guideline

Remaining screws, chassis	EJOTPT® K50x18	2 Nm (1.5 lbf ft)
---------------------------	-------------------	-------------------

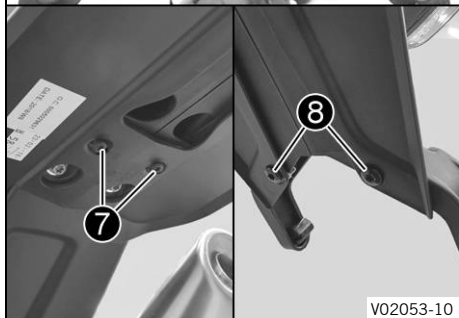

- Mount and tighten screws **8**.

Guideline

Remaining screws, chassis	M5	5 Nm (3.7 lbf ft)
---------------------------	----	-------------------

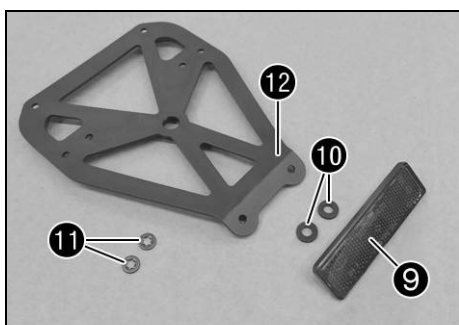

- Mount reflector **9** with rubber bushings **10** and tension washers **11** on the license plate holder **12**.
- Position the license plate bracket on the license plate support.
- Mount and tighten screws **13**.

Guideline

Screw, license plate holder	M5	3 Nm (2.2 lbf ft)
-----------------------------	----	-------------------

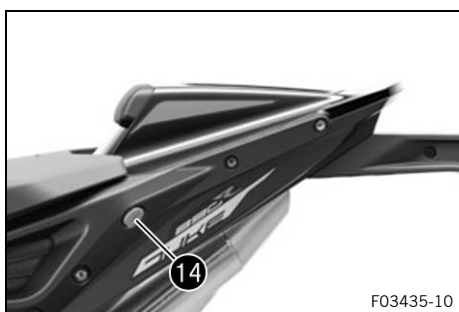

Condition

Operation with a passenger



Info

The vehicle has been set up in the factory for operation with one person.

The components for one-person operation and for operation with a passenger are included in the scope of supply.

Assemble the vehicle according to the customer's requirements and point out legal regulations, e.g., entry in the vehicle documents, if necessary.

- Insert the ignition key in seat lock 14 and turn it clockwise.
- Raise the rear of the seat cover, push it toward the rear, and lift it off.
- Hook holding lugs 15 of the passenger seat onto the storage compartment, lower the rear and push forward.
- Press the passenger seat downward until it clicks into place.

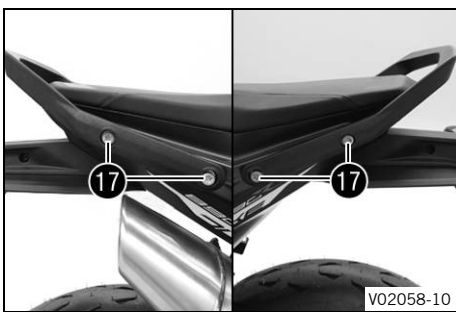
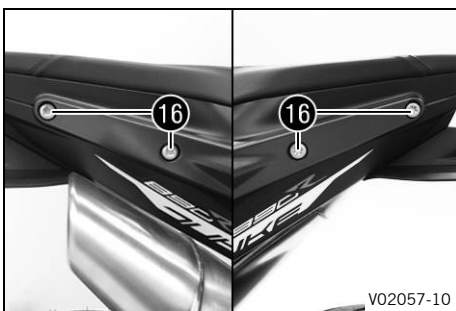
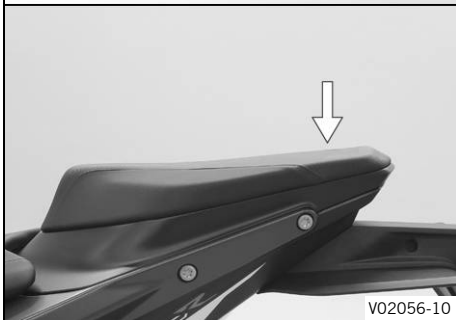
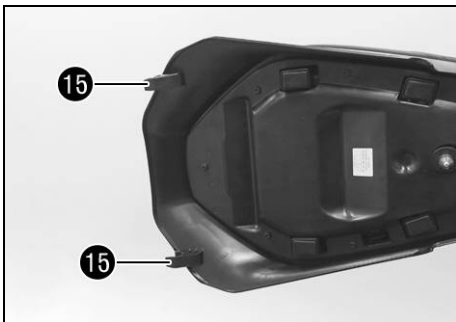

Warning

Danger of accidents The seat can come loose from the anchoring if it is not mounted correctly.

- After assembly, check whether the seat is correctly locked and cannot be pulled up.

- Finally, check that the passenger seat is correctly mounted.

- Remove screws 16.

- Position grab handle and mount and tighten screws 17.

Guideline

Screw, grab handle	M8x50	25 Nm (18.4 lbf ft) Loctite®243™
--------------------	-------	--

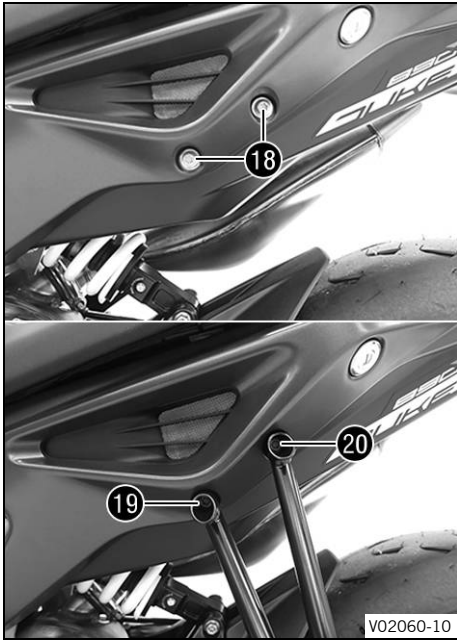

- Remove screws with washers 18.

i Info
Retain the washer for the handover.

- Position the left footrest bracket with the passenger footrest.
- Mount screw 19, but do not tighten yet.

Guideline

Screw, footrest bracket, rear	M8x25	25 Nm (18.4 lbf ft) Loctite®243™
-------------------------------	-------	--

- Mount screw 20, but do not tighten yet.

Guideline

Screw, footrest bracket, rear	M8x40	25 Nm (18.4 lbf ft) Loctite®243™
-------------------------------	-------	--

- Tighten all screws of the left footrest bracket with the passenger footrest.

Guideline

Screw, footrest bracket, rear	M8x25	25 Nm (18.4 lbf ft) Loctite®243™
-------------------------------	-------	--

Screw, footrest bracket, rear	M8x40	25 Nm (18.4 lbf ft) Loctite®243™
-------------------------------	-------	--

- Remove screw 21 with the special washer.
- Remove screws 22.

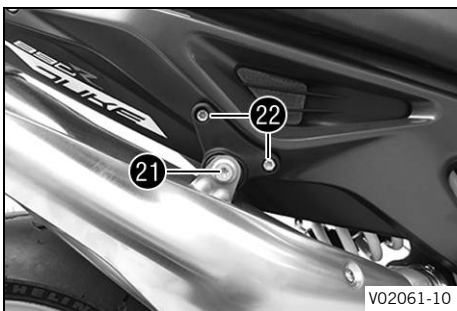

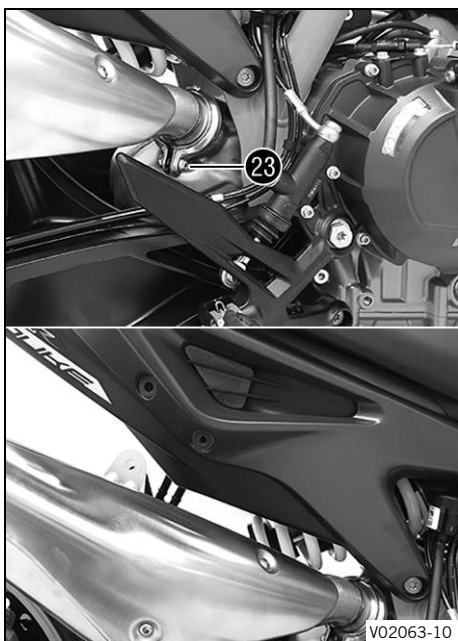

- Loosen clamp screw **23** by several rotations.
- Lower the main silencer.
- Remove the main silencer holder.



Info

Retain the screws for the handover.

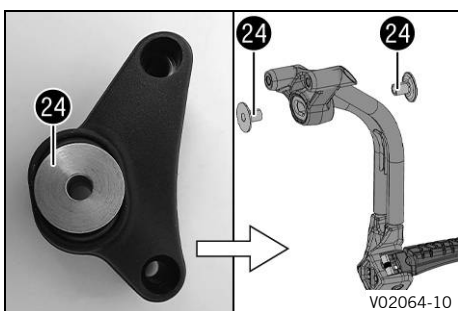

- Remove bushings **24** from the main silencer holder and mount them on the right footrest bracket.



Info

Retain main silencer holder for the handover.

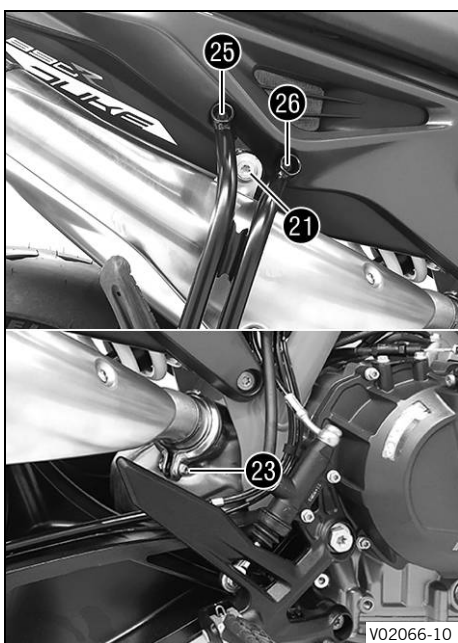

- Position the right footrest bracket with the passenger footrest.
- Mount screw **25**, but do not tighten yet.

Guideline

Screw, footrest bracket, rear	M8x40	25 Nm (18.4 lbf ft) Loctite®243™
-------------------------------	-------	--

- Mount screw **26**, but do not tighten yet.

Guideline

Screw, footrest bracket, rear	M8x25	25 Nm (18.4 lbf ft) Loctite®243™
-------------------------------	-------	--

- Mount screw **21** with the special washer, but do not tighten yet.

Guideline

Screw, main silencer fastening	M8	15 Nm (11.1 lbf ft)
--------------------------------	----	------------------------

- Shake the main silencer slightly to avoid strain.
- Position the main silencer clamp and tighten screw **23**.

Guideline

Screw, main silencer clamp	M6	8 Nm (5.9 lbf ft)
----------------------------	----	-------------------

- Tighten all the screws of the right footrest bracket with the passenger footrest.

Guideline

Screw, footrest bracket, rear	M8x40	25 Nm (18.4 lbf ft) Loctite®243™
Screw, footrest bracket, rear	M8x25	25 Nm (18.4 lbf ft) Loctite®243™
Remaining screws, chassis	M8	25 Nm (18.4 lbf ft)

- Carefully loosen and remove the rear tension belt.



Info

An assistant prevents the motorcycle from falling over.

- Carefully loosen and remove the tension belts around the fork legs.

✓ The vehicle is released at the front.

- Together with an assistant, take the vehicle off the pallet.
- Remove the passenger seat. (📖 p. 12)
- Remove the spare key and **KEYCODECARD** keep in a safe place for the handover.



Warning

Risk of injury Battery acid and battery gases cause serious chemical burns.

- Keep 12 V batteries out of the reach of children.
- Wear suitable protective clothing and safety glasses.
- Avoid contact with battery acid and battery gases.
- Keep sparks or open flames away from the 12 V battery.
- Only charge 12 V batteries in well-ventilated rooms.
- Rinse the affected area immediately with plenty of water in the event of contact with the skin.
- Rinse eyes with water for at least 15 minutes and consult a doctor immediately if battery acid and battery gases get into the eyes.

- Fill the 12 V battery.



Info

Read the notes in the 12 V battery accessory pack.

- Charge the 12-V battery. (📖 p. 13)
- Stow the tool set between the 12-V battery and the front rider's seat.
- Mount the passenger seat. (📖 p. 13)
- Unpack and mount the **KTM PowerParts** included in the delivery (optional).

**Info**

Read the accompanying **KTM PowerParts** fitting instructions.

- Attach the stickers included in the scope of supply (optional).
 - Set time and date.
 - Set kilometers or miles.
 - Check the headlight setting. (📖 p. 17)
 - Refuel. (📖 p. 15)
 - Position all controls in their exact positions on the handlebar. Tighten all screws.
 - Remove the remaining film, padding, the corrugated cardboard, and the other packaging material.
 - Prepare the vehicle according to the specifications in **KTM Dealer.net** for handover to the customer.
-

**Info**

Transport mode must be deactivated to be able to start the motorcycle.



3.1 Adjusting the handlebar position



Warning

Danger of accidents A repaired handlebar poses a safety risk.

If the handlebar is bent or straightened, the material becomes fatigued. The handlebar may break as a result.

- Change the handlebar if the handlebar is damaged or bent.

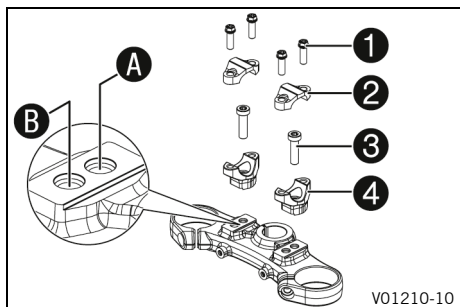

- Remove screws **1**. Take off the handlebar clamps **2**. Position the handlebar so that screws **3** are accessible.



Info

Cover the components to protect them against damage. Do not kink the cables and lines.

- Remove screws **3**. Take off handlebar supports **4**.
- Move the handlebar supports into the desired position **A** or **B**. Mount and tighten screws **3**.

Guideline

Mount the left and right handlebar supports in the same position.

Screw, handlebar support	M10	45 Nm (33.2 lbf ft) Loctite®243™
--------------------------	-----	--

- Position the handlebar.



Info

Make sure the cables and wiring are positioned correctly.

- Position the handlebar clamp. Mount screws **1** and tighten evenly.

Guideline

Screw, handlebar clamp	M8	20 Nm (14.8 lbf ft)
------------------------	----	---------------------

3.2 Removing the passenger seat

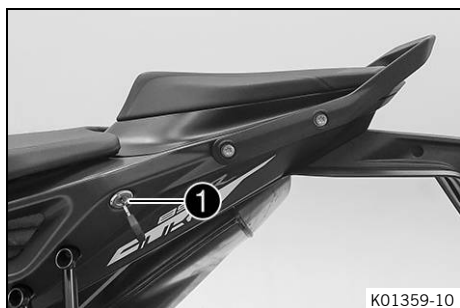

- Insert the ignition key in seat lock **1** and turn it clockwise.
- Raise the rear of the passenger seat cover, push it toward the rear, and remove it upward.
- Remove the ignition key from the seat lock.

i Info
 The vehicle has been set up in the factory for one-person operation. Only an authorized KTM workshop may carry out the conversion. The components for one-person operation and for operation with a passenger are included in the scope of supply. Always ensure that the legal requirements are observed, e.g., entry in the vehicle documents if applicable.

3.3 Mounting the passenger seat

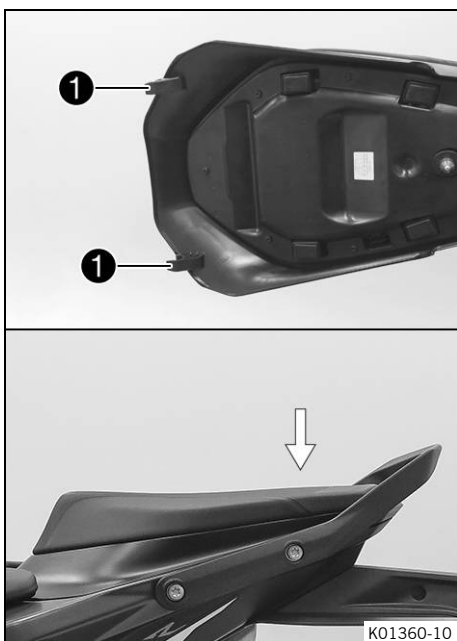

- Hook holding lugs ① of the passenger seat onto the storage compartment, lower the rear and push forward.
- Press the passenger seat downward until it clicks into place.

⚠ Warning
Danger of accidents The seat can come loose from the anchoring if it is not mounted correctly.

- After assembly, check whether the seat is correctly locked and cannot be pulled up.

- Finally, check that the passenger seat is correctly mounted.

i Info
 The vehicle has been set up in the factory for one-person operation. Only an authorized KTM workshop may carry out the conversion. The components for one-person operation and for operation with a passenger are included in the scope of supply. Always ensure that the legal requirements are observed, e.g., entry in the vehicle documents if applicable.

3.4 Charging the 12-V battery

⚠ Warning
Risk of injury Battery acid and battery gases cause serious chemical burns.

- Keep 12 V batteries out of the reach of children.
- Wear suitable protective clothing and safety glasses.
- Avoid contact with battery acid and battery gases.
- Keep sparks or open flames away from the 12 V battery.
- Only charge 12 V batteries in well-ventilated rooms.
- Rinse the affected area immediately with plenty of water in the event of contact with the skin.
- Rinse eyes with water for at least 15 minutes and consult a doctor immediately if battery acid and battery gases get into the eyes.



Note

Environmental hazard 12 V batteries contain environmentally hazardous materials.

- Do not dispose of 12 V batteries as household waste.
- Dispose of 12 V batteries at a collection point for used batteries.



Note

Environmental hazard Hazardous substances cause environmental damage.

- Dispose of oils, grease, filters, fuel, cleaning agents, brake fluid, etc., correctly and in compliance with the applicable regulations.



Info

Even when there is no load on the 12-V battery, it discharges steadily each day. The charging level and the method of charging are very important for the service life of the 12-V battery. Rapid recharging with a high charging current shortens the service life of the battery. If the charging current, charging voltage, or charging time is exceeded, electrolyte escapes through the safety valves. This reduces the capacity of the 12-V battery. If the 12-V battery is depleted by repeated starting, the 12-V battery must be charged immediately. If the 12-V battery is left in a discharged state for an extended period, it will become deeply discharged and sulfating occurs, destroying the battery. The 12-V battery is maintenance-free. The acid level does not have to be checked.

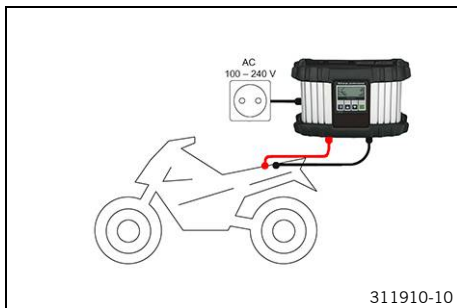

Preparatory work

- Remove the passenger seat. (📖 p. 12)
- Disconnect the negative cable of the 12-V battery. (📖 p. 15)

Main work

- Connect a battery charger to the 12-V battery. Adjust the battery charger.

EU battery charger **XCharge-professional** (00029095050)

Alternative 1

US battery charger **XCharge-professional**
(00029095051)

Alternative 2

UK battery charger **XCharge-professional**
(00029095052)



Info

Follow the instructions of the charger and the manual.

- Disconnect the battery charger after charging the 12-V battery. Guideline

The charging current, charging voltage, and charging time must not be exceeded.

Recharge the 12-V battery regularly when the motorcycle is not being used	3 months
---	----------

Finishing work

- Connect the negative cable of the 12-V battery. (📖 p. 15)
- Mount the passenger seat. (📖 p. 13)
- Set the time and date.



3.5 Disconnecting the negative cable of the 12-V battery

Preparatory work

- Remove the passenger seat. (📖 p. 12)

Main work

- Disconnect negative cable ❶ of the 12-V battery.

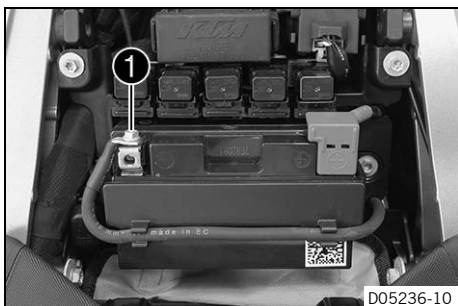

3.6 Connecting the negative cable of the 12-V battery

Main work

- Connect negative cable ❶. Tighten the screw.

Guideline

Screw, battery terminal	M6x12	4.5 Nm (3.32 lbf ft)
-------------------------	-------	-------------------------

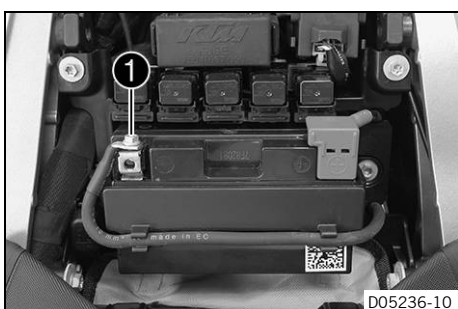

Finishing work

- Mount the passenger seat. (📖 p. 13)
- Set the time and date.

3.7 Refueling



Danger

Fire hazard Fuel is highly flammable.

The fuel in the fuel tank expands when warm and can escape if overfilled.

- Do not fuel the vehicle in the vicinity of open flames or lit cigarettes.
- Switch off the engine for refueling.
- Make sure that no fuel is spilled; particularly not on hot parts of the vehicle.
- If any fuel is spilled, wipe it off immediately.
- Observe the specifications for refueling.



Warning

Danger of poisoning Fuel is poisonous and a health hazard.

- Avoid skin, eye and clothing contact with fuel.
- Immediately consult a doctor if you swallow fuel.
- Do not inhale fuel vapors.
- In case of skin contact, rinse the affected area with plenty of water.
- Rinse the eyes thoroughly with water, and consult a doctor in case of fuel contact with the eyes.
- Change your clothing in case of fuel spills on them.

Note

Material damage Inadequate fuel quality causes the fuel filter to quickly become clogged.

In some countries and regions, the available fuel quality and cleanliness may not be sufficient. This will result in problems with the fuel system.

- Refuel only with clean fuel that meets the specified standards.



Note

Environmental hazard Improper handling of fuel is a danger to the environment.

- Do not allow fuel to enter the groundwater, the soil, or the sewage system.

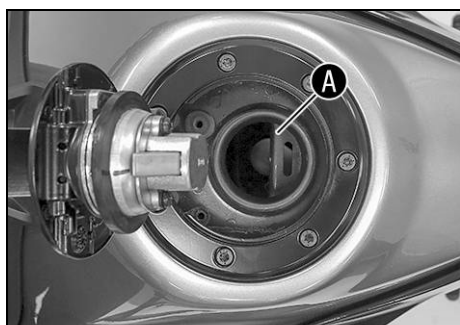

- Switch off the engine.
- Open fuel tank filler cap. (📖 p. 16)
- Fill the fuel tank with fuel up to the lower edge **A** of the filler neck.

Fuel tank capacity, approx.	14 l (3.7 US gal)	Super unleaded (ROZ 95) (📖 p. 23)
-----------------------------	----------------------	---

- Close the fuel tank filler cap. (📖 p. 17)



V01463-10

3.8 Opening fuel tank filler cap



Danger

Fire hazard Fuel is highly flammable.

The fuel in the fuel tank expands when warm and can escape if overfilled.

- Do not fuel the vehicle in the vicinity of open flames or lit cigarettes.
- Switch off the engine for refueling.
- Make sure that no fuel is spilled; particularly not on hot parts of the vehicle.
- If any fuel is spilled, wipe it off immediately.
- Observe the specifications for refueling.



Warning

Danger of poisoning Fuel is poisonous and a health hazard.

- Avoid skin, eye and clothing contact with fuel.
- Immediately consult a doctor if you swallow fuel.
- Do not inhale fuel vapors.
- In case of skin contact, rinse the affected area with plenty of water.
- Rinse the eyes thoroughly with water, and consult a doctor in case of fuel contact with the eyes.
- Change your clothing in case of fuel spills on them.
- Keep fuels correctly in a suitable canister, and out of the reach of children.



Note

Environmental hazard Improper handling of fuel is a danger to the environment.

- Do not allow fuel to enter the groundwater, the soil, or the sewage system.

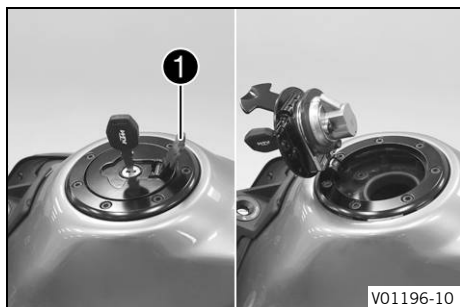

- Lift cover ① of the fuel tank filler cap and insert the ignition key into the lock.

Note

Danger of damage The ignition key may break if overloaded. Damaged ignition keys must be replaced.

- Push down on the fuel tank filler cap to take pressure off the ignition key.
- Turn the ignition key 90° clockwise.
- Lift the fuel tank filler cap.



3.9 Closing the fuel tank filler cap

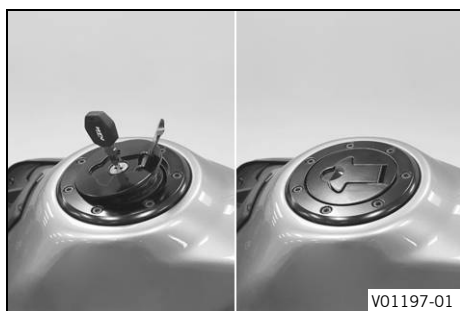

- Fold down the fuel tank filler cap.
- Turn the ignition key 90° clockwise.
- Push down the fuel tank filler cap and turn the ignition key counterclockwise until the lock closes.



Warning

Fire hazard Fuel is highly flammable, toxic and a health hazard.

- Check that the fuel tank filler cap is locked correctly after closing.
- Change your clothing if fuel spills on them.
- Rinse the affected area immediately with plenty of water in the event of contact with the skin.

- Remove the ignition key and close the cover.



3.10 Checking the headlight setting

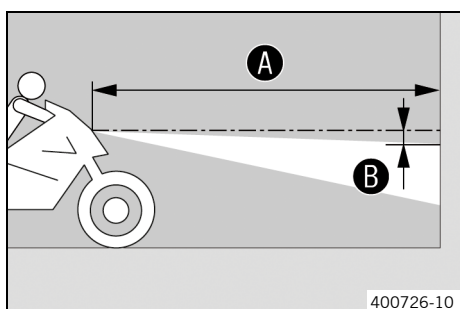

- Position the vehicle upright on a horizontal surface in front of a light wall and make a marking at the height of the center of the low beam headlight.

- Make another mark at a distance ② under the first marking.
Guideline

Distance ②	5 cm (2 in)
------------	-------------

- Position the vehicle perpendicular to the wall at a distance ① from the wall and switch on the low beam.
Guideline

Distance ①	5 m (16 ft)
------------	-------------

- The rider now mounts the motorcycle with luggage and passenger if applicable.
- Check the headlight setting.

The light-dark boundary must be exactly on the lower marking when the motorcycle is ready to be operated with the rider mounted along with any luggage and a passenger if applicable.

- » If the boundary between light and dark does not meet specifications:
 - Adjust the headlight range. (📖 p. 18)

3.11 Adjusting the headlight range

Preparatory work

- Check the headlight setting. (📖 p. 17)

Main work

- Turn adjusting screw **1** to adjust the headlight range.

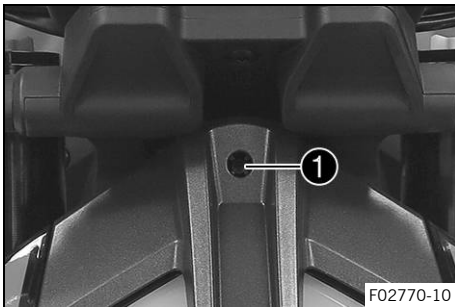

Info

Turn clockwise to increase the headlight range; turn counterclockwise to reduce the headlight range. If you have a payload, you may have to correct the headlight range.

Screw **1** also secures the headlight. Ensure the screw is always screwed in far enough.

- Set the headlight to marking **B**.

Guideline

The light-dark boundary must lie exactly on lower marking **B** when the motorcycle is ready to operate with the rider mounted along with any luggage and a passenger, if applicable.

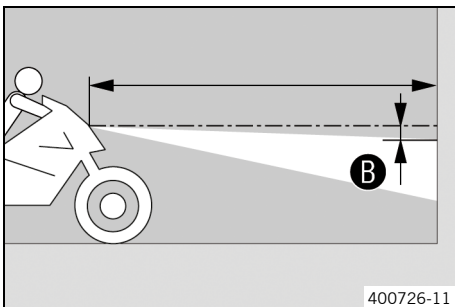

4.1 Chassis tightening torques

Remaining screws, chassis	EJOTPT® K45x12	1 Nm (0.7 lbf ft)	
Remaining screws, chassis	EJOTPT® K50x12	1 Nm (0.7 lbf ft)	
Remaining screws, chassis	EJOTPT® K50x14	1 Nm (0.7 lbf ft)	
Remaining screws, chassis	EJOTPT® K50x16	2 Nm (1.5 lbf ft)	
Remaining screws, chassis	EJOTPT® K50x18	2 Nm (1.5 lbf ft)	
Screw, headlight	EJOTPT® K50x14	3 Nm (2.2 lbf ft)	
Remaining nuts, chassis	M4	3 Nm (2.2 lbf ft)	
Remaining screws, chassis	M4	3 Nm (2.2 lbf ft)	
Screw, fixed grip, left	M4	3 Nm (2.2 lbf ft)	
Remaining nuts, chassis	M5	5 Nm (3.7 lbf ft)	
Remaining screws, chassis	M5	5 Nm (3.7 lbf ft)	
Screw, air filter box	M5	3 Nm (2.2 lbf ft)	
Screw, brake fluid reservoir for rear brake	M5	5 Nm (3.7 lbf ft)	Loctite®243™
Screw, combination instrument	M5	4 Nm (3 lbf ft)	
Screw, combination switch, left	M5	2 Nm (1.5 lbf ft)	
Screw, combination switch, right	M5	5 Nm (3.7 lbf ft)	
Screw, engine sprocket cover	M5	5 Nm (3.7 lbf ft)	Loctite®243™
Screw, fuel level sensor	M5	3 Nm (2.2 lbf ft)	
Screw, headlight mask	M5	5 Nm (3.7 lbf ft)	Loctite®243™
Screw, heat guard	M5	5 Nm (3.7 lbf ft)	Loctite®243™
Screw, side stand sensor	M5	2 Nm (1.5 lbf ft)	Loctite®243™
Screw, support roller	M5	4 Nm (3 lbf ft)	Loctite®243™
Screw, throttle grip	M5	3.5 Nm (2.58 lbf ft)	
Screw, trim	M5	3 Nm (2.2 lbf ft)	
Nut, cable on starter motor	M6	5 Nm (3.7 lbf ft)	
Nut, hand brake lever	M6	5 Nm (3.7 lbf ft)	
Nut, push rod, foot brake lever	M6	6 Nm (4.4 lbf ft)	
Nut, shift rod	M6	6 Nm (4.4 lbf ft)	
Nut, shift rod	M6LH	6 Nm (4.4 lbf ft)	
Remaining nuts, chassis	M6	10 Nm (7.4 lbf ft)	
Remaining screws, chassis	M6	10 Nm (7.4 lbf ft)	
Screw, angle sensor	M6	5 Nm (3.7 lbf ft)	
Screw, ball joint of push rod on foot brake cylinder	M6	10 Nm (7.4 lbf ft)	Loctite®243™
Screw, battery terminal	M6x12	4.5 Nm (3.32 lbf ft)	
Screw, battery terminal	M6x20	4.5 Nm (3.32 lbf ft)	
Screw, brake assembly	M6	5 Nm (3.7 lbf ft)	
Screw, clutch assembly	M6	5 Nm (3.7 lbf ft)	

4 TECHNICAL DATA

Screw, foot brake cylinder	M6	10 Nm (7.4 lbf ft) Loctite®243™
Screw, foot brake lever stub	M6	10 Nm (7.4 lbf ft) Loctite®243™
Screw, front rider's seat	M6	10 Nm (7.4 lbf ft) Loctite®243™
Screw, fuel tank rollers	M6	10 Nm (7.4 lbf ft) Loctite®243™
Screw, fuel tank spoiler	M6	3 Nm (2.2 lbf ft)
Screw, ground wire on frame	M6	6 Nm (4.4 lbf ft)
Screw, ground wire to starter motor	M6	10 Nm (7.4 lbf ft)
Screw, ignition lock (tamper-proof screw)	M6	Tighten until the head tears off. Loctite®243™
Screw, license plate holder	M6	10 Nm (7.4 lbf ft) Loctite®243™
Screw, magnetic holder on side stand	M6	2 Nm (1.5 lbf ft) Loctite®243™
Screw, main silencer clamp	M6	8 Nm (5.9 lbf ft)
Screw, manifold clamp	M6	8 Nm (5.9 lbf ft)
Screw, radiator bracket, bottom	M6	5 Nm (3.7 lbf ft)
Screw, seat lock	M6	8 Nm (5.9 lbf ft) Loctite® 222™
Screw, shift lever stub	M6	10 Nm (7.4 lbf ft) Loctite®243™
Screw, shift rod	M6	10 Nm (7.4 lbf ft) Loctite®243™
Screw, shift shaft deflector on shift shaft	M6	10 Nm (7.4 lbf ft) Loctite®243™
Screw, wheel speed sensor	M6	6 Nm (4.4 lbf ft)
Nut, manifold on cylinder head	M8	Tighten the nuts evenly. Do not bend the metal. 20 Nm (14.8 lbf ft) Copper paste
Nut, rear sprocket screw	M8	35 Nm (25.8 lbf ft) Loctite®2701™
Pin, rear brake caliper	M8	14 Nm (10.3 lbf ft)
Remaining nuts, chassis	M8	25 Nm (18.4 lbf ft)
Remaining screws, chassis	M8	25 Nm (18.4 lbf ft)
Screw, bottom triple clamp	M8	12 Nm (8.9 lbf ft)
Screw, cross member	M8x18	25 Nm (18.4 lbf ft) Loctite®243™
Screw, cross member in rear	M8x35	25 Nm (18.4 lbf ft) Loctite®243™
Screw, engine fixing arm linkage bracket	M8	25 Nm (18.4 lbf ft) Loctite®243™
Screw, foot brake lever	M8	25 Nm (18.4 lbf ft) Loctite®2701™
Screw, footrest bracket, rear	M8x25	25 Nm (18.4 lbf ft) Loctite®243™

Screw, footrest bracket, rear	M8x40	25 Nm (18.4 lbf ft) Loctite®243™
Screw, fork stub	M8	15 Nm (11.1 lbf ft)
Screw, front brake disc	M8	28 Nm (20.7 lbf ft) Loctite®2701™
Screw, grab handle	M8x50	25 Nm (18.4 lbf ft) Loctite®243™
Screw, handlebar clamp	M8	20 Nm (14.8 lbf ft)
Screw, main silencer fastening	M8	15 Nm (11.1 lbf ft)
Screw, passenger seat bracket	M8	25 Nm (18.4 lbf ft) Loctite®243™
Screw, presilencer on frame	M8	25 Nm (18.4 lbf ft) Loctite®243™
Screw, rear brake disc	M8	28 Nm (20.7 lbf ft) Loctite®2701™
Screw, shift lever	M8	25 Nm (18.4 lbf ft) Loctite®2701™
Screw, spring holder plate on side stand bracket	M8	15 Nm (11.1 lbf ft) Loctite®2701™
Screw, steering damper on holder	M8	8 Nm (5.9 lbf ft) Loctite®243™
Screw, steering damper on triple clamp	M8	8 Nm (5.9 lbf ft) Loctite®243™
Screw, steering stem	M8	20 Nm (14.8 lbf ft) Loctite®243™
Screw, subframe brace	M8	25 Nm (18.4 lbf ft) Loctite®243™
Screw, top triple clamp	M8	15 Nm (11.1 lbf ft)
Engine carrying screw	M10	45 Nm (33.2 lbf ft) Loctite®243™
Remaining nuts, chassis	M10	45 Nm (33.2 lbf ft)
Remaining screws, chassis	M10	45 Nm (33.2 lbf ft)
Screw, front footrest bracket	M10x65	45 Nm (33.2 lbf ft) Loctite®243™
Screw, front footrest bracket	M10x80	45 Nm (33.2 lbf ft) Loctite®243™
Screw, handlebar support	M10	45 Nm (33.2 lbf ft) Loctite®243™
Screw, side stand	M10	35 Nm (25.8 lbf ft) Loctite®243™
Screw, side stand bracket	M10	45 Nm (33.2 lbf ft) Loctite®243™
Screw, subframe	M10	50 Nm (36.9 lbf ft) Loctite®243™
Banjo bolt, brake line	M10x1	25 Nm (18.4 lbf ft)
Screw, front brake caliper	M10x1.25	45 Nm (33.2 lbf ft) Loctite®243™
Screw, bottom shock absorber	M12	80 Nm (59 lbf ft) Loctite®2701™
Screw, swingarm pivot	M12	100 Nm (73.8 lbf ft)

4 TECHNICAL DATA

Screw, top shock absorber	M12	80 Nm (59 lbf ft) Loctite®2701™
Lambda sensor	M18x1.5	50 Nm (36.9 lbf ft)
Adjusting screw, swingarm	M20LHx1.5	10 Nm (7.4 lbf ft)
Screw, steering head	M20x1.5	18 Nm (13.3 lbf ft)
Nut, rear wheel spindle	M25x1.5	90 Nm (66.4 lbf ft) Thread and contact area of wheel spindle greased
Screw, front wheel spindle	M25x1.5	45 Nm (33.2 lbf ft) Thread greased

Super unleaded (ROZ 95)

Standard/classification

- DIN EN 228 (ROZ 95)

Guideline

- Only use super unleaded fuel that matches or is equivalent to the specified standard.
- Fuel with an ethanol content of up to 10% (E10 fuel) is safe to use.



Info

Do **not** use fuel containing methanol (e.g., M15, M85, M100) or more than 10% ethanol (e.g., E15, E25, E85, E100).

**READY TO
RACE**



3214444en

03/2021



KTM

KTM Sportmotorcycle GmbH
5230 Mattighofen/Austria
KTM.com



REG. NO. 12 100 6061

Photo: Mitterbauer/KISKA/KTM