

65 SX

Art. no. 3214361en





Perform the work described in these setup instructions before the vehicle is delivered to the customer.

Read the setup instructions in their entirety before beginning work.

These setup instructions were written to correspond to the latest state of this series. We reserve the right to make changes in the interest of technical advancement without at the same time updating this manual.

We shall not provide a description of general workshop methods. Likewise, safety rules that apply in a workshop are not specified here. It is assumed that the work will be performed by a fully trained mechanic.

All specifications contained herein are non-binding. KTM Sportmotorcycle GmbH specifically reserves the right to modify or delete technical specifications, prices, colors, forms, materials, services, designs, equipment, etc., without prior notice and without specifying reasons, to adapt these to local conditions, as well as to stop production of a particular model without prior notice. KTM accepts no liability for delivery options, deviations from figures and descriptions, misprints, and other errors. The models portrayed partly contain special equipment that does not belong to the regular scope of supply.

© 2021 KTM Sportmotorcycle GmbH, Mattighofen Austria

All rights reserved

Reproduction, even in part, as well as copying of all kinds, is permitted only with the express written permission of the copyright owner.



ISO 9001(12 100 6061)

KTM applies quality assurance processes that lead to the highest possible product quality as defined in the ISO 9001 international quality management standard.

Issued by: TÜV Management Service

REG.NO. 12 100 6061

KTM Sportmotorcycle GmbH  
Stallhofnerstraße 3  
5230 Mattighofen, Austria

This document is valid for the following models:

65 SX (F6001U6)



# 1 MEANS OF REPRESENTATION

## 1.1 Symbols used

The meaning of specific symbols is described below.



Indicates an expected reaction (e.g. of a work step or a function).



Indicates an unexpected reaction (e.g. of a work step or a function).



Indicates a page reference (more information is provided on the specified page).



Indicates information with more details or tips.



Indicates the result of a testing step.



Indicates a voltage measurement.



Indicates a current measurement.



Indicates a resistance measurement.



Indicates the end of an activity including potential rework.

## 1.2 Formats used

The typographical formats used in this document are explained below.

**Proprietary name**

Indicates a proprietary name.

**Name®**

Indicates a protected name.

**Brand™**

Indicates a brand available on the open market.

**Underlined terms**

Refer to technical details of the vehicle or indicate technical terms, which are explained in the glossary.

## 2.1 Unpacking and setting up the vehicle



- Open the box.



### Info

To avoid damaging the vehicle while setting it up, do not remove the protective film on each component until installing the component, and leave it on the vehicle until work has been completed.

- Remove the two cable ties on the triple clamp.
- Take out the front wheel, fender, and the separate enclosure from the box.
- Remove the separate enclosure and unpack it. Check the separate enclosure for completeness.



### Info

The procedure in the event of missing components is described in the customer service manual.

- Lift the vehicle out of the box with the assistance of another person.
- Raise the motorcycle with a lift stand. (📖 p. 5)
- Check the vehicle for transport damage.



### Info

The procedure in the event of transport damage is described in the customer service manual.

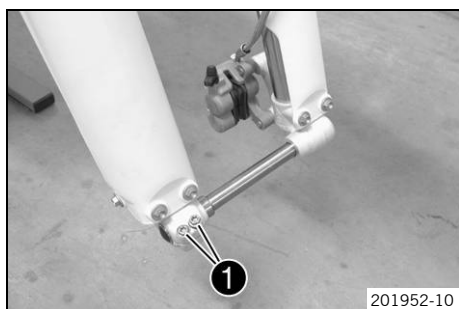

- Loosen screws ①.
- Remove the wheel spindle.
- Install front fender. (📖 p. 10)
- Install the front wheel. (📖 p. 5)
- Remove the protective film from the handlebar and start number plate.

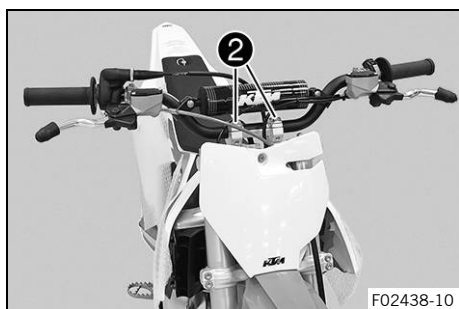

### Warning

**Danger of accidents** A repaired handlebar poses a safety risk.

If the handlebar is bent or straightened, the material becomes fatigued. The handlebar may break as a result.

- Change the handlebar if the handlebar is damaged or bent.

- Position the handlebar with handlebar clamps ②.



**Info**

Make sure the cables and wiring are positioned correctly.

- Mount and tighten the screws.

Guideline

Screw, handlebar clamp	M8	20 Nm (14.8 lbf ft)
------------------------	----	---------------------

- Check the handlebar position.
  - » If the handlebar position is not adjusted as required by the customer:
    - Adjust the handlebar position. (📖 p. 6)
- Remove the screw of the brake line guide. Position the brake line. Mount the brake line guide again and tighten the screw.
- Check that the controls on the handlebar are correctly positioned and firmly seated.
- Remove the seat. (📖 p. 7)
- Remove the fuel tank. (📖 p. 8)
- Position the service hour counter and fix it in place using an adhesive pad.
- Route the cable on the frame and attach it to the ignition wire.



**Info**

Do not kink or damage the cable.

- Check that the wiring harness, throttle cables, and brake line have the necessary freedom of movement and are correctly routed.
- Install the fuel tank. (📖 p. 9)
- Mount the seat. (📖 p. 7)
- Mount the footrests with the springs and pins. Secure the pins using the washers and cotter pins.

Footrest spring plier (58429083000)

- Fill up with fuel. (📖 p. 11)
- Remove the remaining plastic packaging, corrugated cardboard, and other packaging material.
- Remove the motorcycle from the lift stand. (📖 p. 5)
- Prepare the vehicle according to the specifications in **KTM Dealer.net** for handover to the customer.

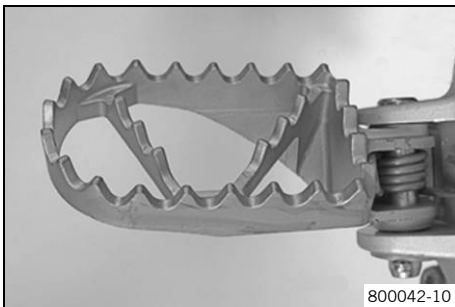

### 3.1 Raising the motorcycle with a lift stand

**Note**

**Danger of damage** The parked vehicle can roll away or fall over.

- Park the vehicle on a firm and level surface.

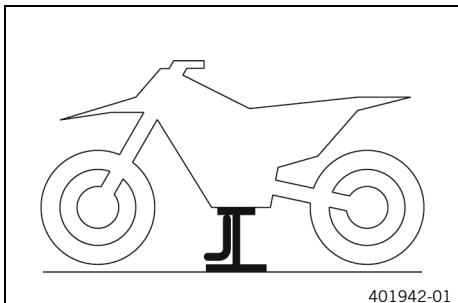

- Raise the motorcycle at the frame underneath the engine.

Lift stand (78929955100)

- ✓ Neither wheel is in contact with the ground.
- Secure the motorcycle against falling over.

### 3.2 Removing the motorcycle from the lift stand

**Note**

**Danger of damage** The parked vehicle can roll away or fall over.

- Park the vehicle on a firm and level surface.

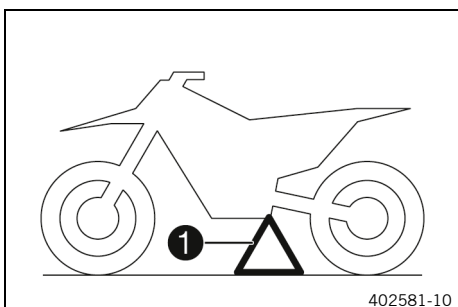

- Remove the motorcycle from the lift stand.
- Remove the lift stand.
- To park the motorcycle, insert plug-in stand 1 into the plug-in stand bracket on the left side of the vehicle.

**i Info** Remove the plug-in stand before riding.

### 3.3 Installing the front wheel



**Warning**

**Danger of accidents** Oil or grease on the brake discs reduces the braking effect.

- Always keep the brake discs free of oil and grease.
- Clean the brake discs with brake cleaner when necessary.

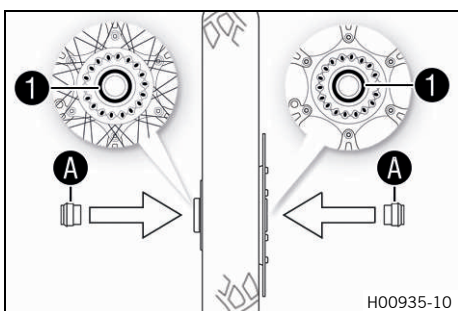

- Check the wheel bearing for damage and wear.
  - » If the wheel bearing is damaged or worn:
    - Change front wheel bearing.
- Clean and grease shaft seal rings 1 and contact surfaces A of the spacers.

Long-life grease (📖 p. 17)

- Insert the spacers.

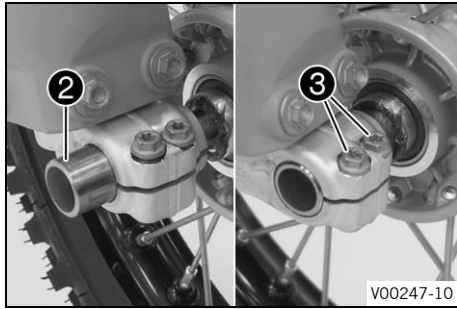

- Clean and grease wheel spindle ②.

Long-life grease (📖 p. 17)

- Position the front wheel.
  - ✓ The brake linings are correctly positioned.
- Insert the wheel spindle.
- Tighten screws ③.

Guideline

Screw, fork stub	M6	10 Nm (7.4 lbf ft)
------------------	----	--------------------

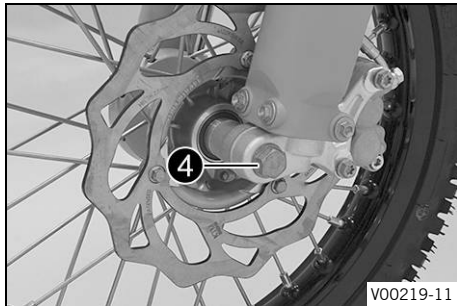

- Mount and tighten screw ④.

Guideline

Screw, front wheel spindle	M10	40 Nm (29.5 lbf ft) <b>Loctite®243™</b>
----------------------------	-----	--

- Remove the motorcycle from the lift stand. (📖 p. 5)

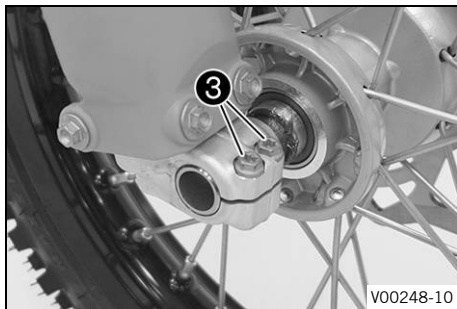

- Operate the hand brake lever several times until the brake linings are seated correctly against the brake disc.
- Loosen screws ③.
- Operate the front brake and compress the fork a few times firmly.
- ✓ The fork legs straighten.

- Tighten screws ③.

Guideline

Screw, fork stub	M6	10 Nm (7.4 lbf ft)
------------------	----	--------------------

## 3.4 Adjusting the handlebar position



### Warning

**Danger of accidents** A repaired handlebar poses a safety risk.

If the handlebar is bent or straightened, the material becomes fatigued. The handlebar may break as a result.

- Change the handlebar if the handlebar is damaged or bent.

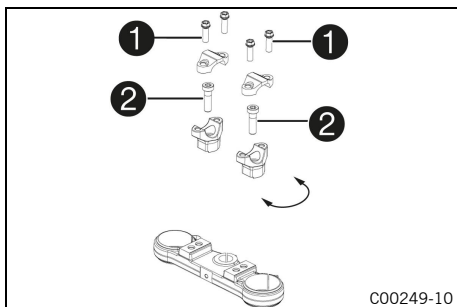

- Remove screws ①. Take off the handlebar clamps. Remove the handlebar and lay it to one side.



### Info

Cover the components to protect them against damage. Do not kink the cables and lines.

- Remove screws ②. Take off handlebar supports.
- Place handlebar supports in required position. Mount and tighten screws ②.



Guideline

Screw, handlebar support	M10	40 Nm (29.5 lbf ft) <b>Loctite®243™</b>
--------------------------	-----	--

- Position the handlebar.

**i Info**  
Make sure the cables and wiring are positioned correctly.

- Position the handlebar clamps. Mount screws **1** and tighten evenly.

Guideline

Screw, handlebar clamp	M8	20 Nm (14.8 lbf ft)
------------------------	----	---------------------

**i Info**  
Make sure the installed gaps are even.

**3.5 Removing the seat**

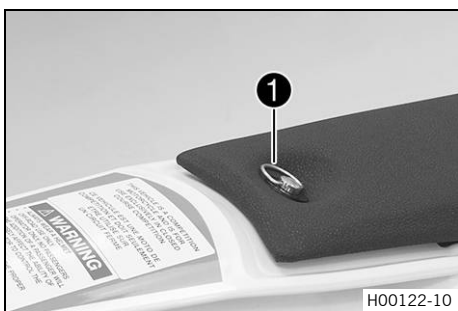

- Open quick release **1** and raise the rear of the seat.
- Pull back the seat and remove it.

**3.6 Mounting the seat**

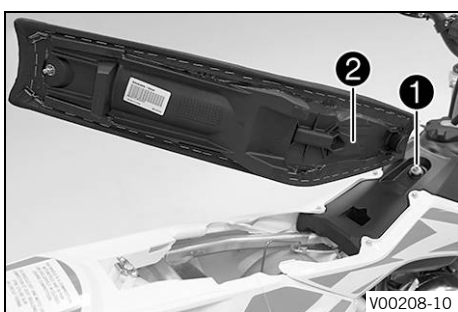

- Hook seat onto screw **1** and lower the seat at the rear and push it forward.
- ✓ Holding lug **2** hooks into the fuel tank.

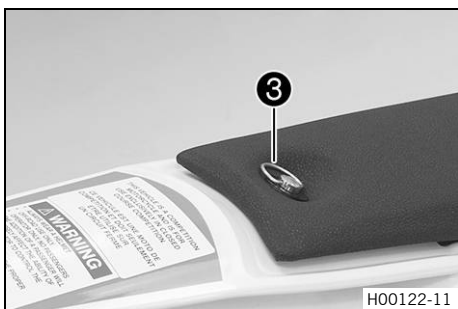

- Close quick release **3**.

## 3.7 Removing the fuel tank



### Danger

**Fire hazard** Fuel is highly flammable.

The fuel in the fuel tank expands when warm and can escape if overfilled.

- Do not fuel the vehicle in the vicinity of open flames or lit cigarettes.
- Switch off the engine for refueling.
- Make sure that no fuel is spilled; particularly not on hot parts of the vehicle.
- If any fuel is spilled, wipe it off immediately.
- Observe the specifications for refueling.



### Warning

**Danger of poisoning** Fuel is poisonous and a health hazard.

- Avoid skin, eye and clothing contact with fuel.
- Immediately consult a doctor if you swallow fuel.
- Do not inhale fuel vapors.
- In case of skin contact, rinse the affected area with plenty of water.
- Rinse the eyes thoroughly with water, and consult a doctor in case of fuel contact with the eyes.
- Change your clothing in case of fuel spills on them.
- Keep fuels correctly in a suitable canister, and out of the reach of children.

### Preparatory work

- Remove the seat. (📖 p. 7)
- Turn the knurled screw on the fuel tap all the way clockwise.

### Main work

- Remove screw ❶.

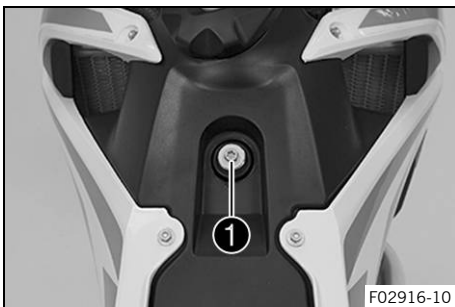

- Remove screws ❷.



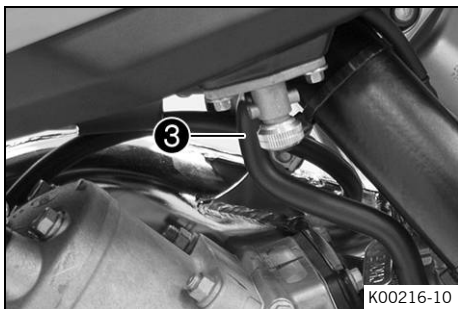

- Pull off fuel hose ③.

**i Info**  
Remaining fuel may flow out of the fuel hose.

- Pull fuel tank breather out of the steering stem.
- Pull both spoilers off laterally from the radiator bracket and lift off the fuel tank.

### 3.8 Installing the fuel tank



**Danger**

**Fire hazard** Fuel is highly flammable.

The fuel in the fuel tank expands when warm and can escape if overfilled.

- Do not fuel the vehicle in the vicinity of open flames or lit cigarettes.
- Switch off the engine for refueling.
- Make sure that no fuel is spilled; particularly not on hot parts of the vehicle.
- If any fuel is spilled, wipe it off immediately.
- Observe the specifications for refueling.



**Warning**

**Danger of poisoning** Fuel is poisonous and a health hazard.

- Avoid skin, eye and clothing contact with fuel.
- Immediately consult a doctor if you swallow fuel.
- Do not inhale fuel vapors.
- In case of skin contact, rinse the affected area with plenty of water.
- Rinse the eyes thoroughly with water, and consult a doctor in case of fuel contact with the eyes.
- Change your clothing in case of fuel spills on them.
- Keep fuels correctly in a suitable canister, and out of the reach of children.

**Main work**

- Check the throttle cable routing. (🔧 p. 13)
- Position the fuel tank and fit the two spoilers to the sides of the radiator mount.
- Make sure that no cables or throttle cables are trapped or damaged.
- Mount fuel hose ①.





- Mount and tighten screws **2**.

Guideline

Screw, fuel tank spoiler on radiator	M6	6 Nm (4.4 lbf ft)
--------------------------------------	----	-------------------

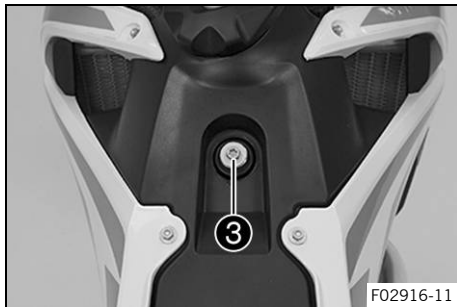

- Mount and tighten screw **3**.

Guideline

Remaining screws, chassis	M6	10 Nm (7.4 lbf ft)
---------------------------	----	--------------------

- Position the fuel tank breather in the steering stem.

### Finishing work

- Mount the seat. (📖 p. 7)

## 3.9 Installing front fender

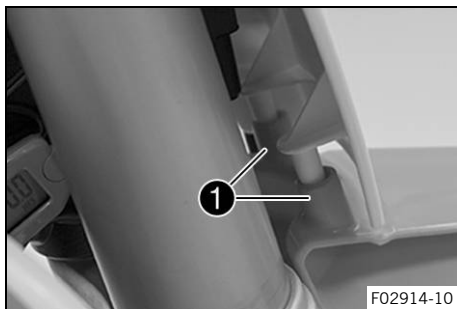

- Position start number plate on the fender.
  - ✓ The holding lugs of the start number plate engage in drill holes **1** of the fender.

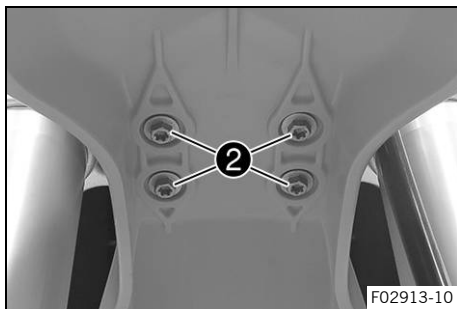

- Position fender on the lower triple clamp, mount and tighten screws **2**.

Guideline

Screw, fender	M6	6 Nm (4.4 lbf ft)
---------------	----	-------------------

3.10 Refueling



**Danger**

**Fire hazard** Fuel is highly flammable.

The fuel in the fuel tank expands when warm and can escape if overfilled.

- Do not fuel the vehicle in the vicinity of open flames or lit cigarettes.
- Switch off the engine for refueling.
- Make sure that no fuel is spilled; particularly not on hot parts of the vehicle.
- If any fuel is spilled, wipe it off immediately.
- Observe the specifications for refueling.



**Warning**

**Danger of poisoning** Fuel is poisonous and a health hazard.

- Avoid skin, eye and clothing contact with fuel.
- Immediately consult a doctor if you swallow fuel.
- Do not inhale fuel vapors.
- In case of skin contact, rinse the affected area with plenty of water.
- Rinse the eyes thoroughly with water, and consult a doctor in case of fuel contact with the eyes.
- Change your clothing in case of fuel spills on them.



**Note**

**Environmental hazard** Improper handling of fuel is a danger to the environment.

- Do not allow fuel to enter the groundwater, the soil, or the sewage system.

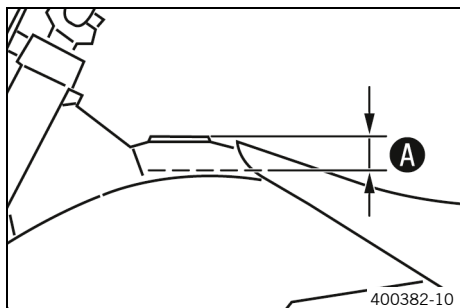

- Switch off the engine.
- Open the fuel tank filler cap. (📖 p. 12)
- Fill the fuel tank with fuel up to measurement **A**.

Guideline

Measurement of <b>A</b>	35 mm (1.38 in)
-------------------------	-----------------

Fuel tank capacity, approx.	3.5 l (3.7 qt.)	Super unleaded (95 octane) mixed with 2-stroke engine oil (1:60) (📖 p. 16)
-----------------------------	-----------------	--

Engine oil, 2-stroke (📖 p. 16)
--------------------------------

- Close the fuel tank filler cap. (📖 p. 12)



## 3.11 Opening the fuel tank filler cap



### Danger

**Fire hazard** Fuel is highly flammable.

The fuel in the fuel tank expands when warm and can escape if overfilled.

- Do not fuel the vehicle in the vicinity of open flames or lit cigarettes.
- Switch off the engine for refueling.
- Make sure that no fuel is spilled; particularly not on hot parts of the vehicle.
- If any fuel is spilled, wipe it off immediately.
- Observe the specifications for refueling.



### Warning

**Danger of poisoning** Fuel is poisonous and a health hazard.

- Avoid skin, eye and clothing contact with fuel.
- Immediately consult a doctor if you swallow fuel.
- Do not inhale fuel vapors.
- In case of skin contact, rinse the affected area with plenty of water.
- Rinse the eyes thoroughly with water, and consult a doctor in case of fuel contact with the eyes.
- Change your clothing in case of fuel spills on them.
- Keep fuels correctly in a suitable canister, and out of the reach of children.



### Note

**Environmental hazard** Improper handling of fuel is a danger to the environment.

- Do not allow fuel to enter the groundwater, the soil, or the sewage system.



- Press release button **1**, turn the fuel tank filler cap counter-clockwise, and lift it off.

## 3.12 Closing the fuel tank filler cap

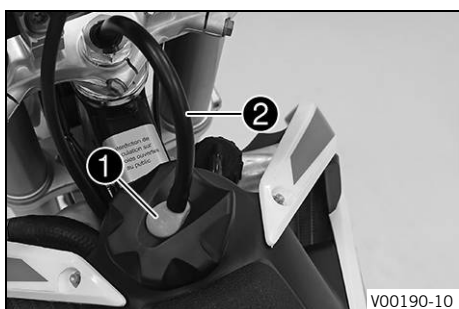

- Mount the fuel tank filler cap and turn it clockwise until release button **1** engages.



### Info

Route fuel tank breather hose **2** without kinks.

### 3.13 Checking the throttle cable routing



#### Warning

**Danger of accidents** The throttle cable may slip out of the guide if routed incorrectly. The throttle slide will then no longer be closed and the speed can no longer be controlled.

- Make sure that the throttle cable routing and the play in throttle cable complies with the specification.

#### Preparatory work

- Remove the seat. (🔧 p. 7)
- Turn the knurled screw on the fuel tap all the way clockwise.
- Remove the fuel tank. (🔧 p. 8)

#### Main work

- Check the throttle cable routing.

The throttle cable must be routed behind the handlebar, behind the coolant hose and on the left of the frame.

- » If the throttle cable is not routed as specified:
  - Correct the throttle cable routing.

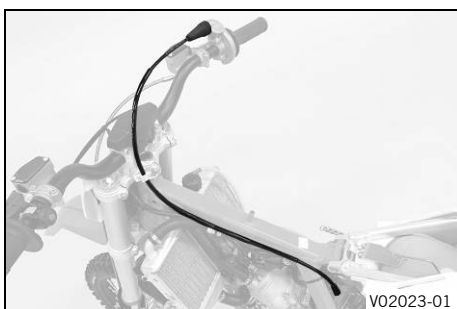

#### Finishing work

- Install the fuel tank. (🔧 p. 9)
- Mount the seat. (🔧 p. 7)



## 4 TECHNICAL DATA

### 4.1 Chassis tightening torques

Hose clip, carburetor	-	2.8 Nm (2.07 lbf ft)	
Screw, brake hose bracket	<b>EJOT</b>	1.7 Nm (1.25 lbf ft)	
Stop button screw	M3	0.4 Nm (0.3 lbf ft)	
Spoke nipple	M3.5	3 Nm (2.2 lbf ft)	
Screw, throttle slide cover	M4	2 Nm (1.5 lbf ft)	
Remaining nuts, chassis	M5	5 Nm (3.7 lbf ft)	
Remaining screws, chassis	M5	5 Nm (3.7 lbf ft)	
Nut, push rod, foot brake lever	M6	6 Nm (4.4 lbf ft)	
Remaining nuts, chassis	M6	10 Nm (7.4 lbf ft)	
Remaining screws, chassis	M6	10 Nm (7.4 lbf ft)	
Screw, ball joint of push rod on foot brake cylinder	M6	10 Nm (7.4 lbf ft)	<b>Loctite®243™</b>
Screw, chain sliding guard	M6	10 Nm (7.4 lbf ft)	
Screw, clutch master cylinder	M6	5 Nm (3.7 lbf ft)	
Screw, fender	M6	6 Nm (4.4 lbf ft)	
Screw, foot brake cylinder	M6	10 Nm (7.4 lbf ft)	
Screw, fork stub	M6	10 Nm (7.4 lbf ft)	
Screw, front brake disc	M6	14 Nm (10.3 lbf ft)	<b>Loctite®243™</b>
Screw, front brake linings	M6	10 Nm (7.4 lbf ft)	
Screw, fuel tank spoiler on radiator	M6	6 Nm (4.4 lbf ft)	
Screw, hand brake cylinder	M6	5 Nm (3.7 lbf ft)	
Screw, rear brake disc	M6	14 Nm (10.3 lbf ft)	<b>Loctite®243™</b>
Screw, rear brake lining	M6	10 Nm (7.4 lbf ft)	
Screw, throttle grip	M6	4.5 Nm (3.32 lbf ft)	
Start number plate screw	M6	4 Nm (3 lbf ft)	
Fitting, engine mounting bracket	M8	30 Nm (22.1 lbf ft)	
Nut, foot brake lever stop	M8	20 Nm (14.8 lbf ft)	
Nut, rim lock	M8	10 Nm (7.4 lbf ft)	
Remaining nuts, chassis	M8	25 Nm (18.4 lbf ft)	
Remaining screws, chassis	M8	25 Nm (18.4 lbf ft)	
Screw, bottom triple clamp	M8	15 Nm (11.1 lbf ft)	
Screw, engine bracket	M8	30 Nm (22.1 lbf ft)	<b>Loctite®2701™</b>
Screw, engine sprocket cover	M8	15 Nm (11.1 lbf ft)	
Screw, front brake caliper	M8	20 Nm (14.8 lbf ft)	<b>Loctite®243™</b>
Screw, handlebar clamp	M8	20 Nm (14.8 lbf ft)	
Screw, rear brake caliper	M8x20	18 Nm (13.3 lbf ft)	<b>Loctite®243™</b>
Screw, rear brake caliper	M8x40	18 Nm (13.3 lbf ft)	<b>Loctite®243™</b>
Screw, rear sprocket	M8	25 Nm (18.4 lbf ft)	<b>Loctite®243™</b>
Screw, steering stem	M8	20 Nm (14.8 lbf ft)	



Screw, subframe	M8	35 Nm (25.8 lbf ft) <b>Loctite®2701™</b>
Screw, top triple clamp	M8	20 Nm (14.8 lbf ft)
Remaining nuts, chassis	M10	45 Nm (33.2 lbf ft)
Remaining screws, chassis	M10	45 Nm (33.2 lbf ft)
Screw, bottom shock absorber	M10	45 Nm (33.2 lbf ft) <b>Loctite®243™</b>
Screw, foot brake lever	M10	35 Nm (25.8 lbf ft) <b>Loctite®243™</b>
Screw, front wheel spindle	M10	40 Nm (29.5 lbf ft) <b>Loctite®243™</b>
Screw, handlebar support	M10	40 Nm (29.5 lbf ft) <b>Loctite®243™</b>
Screw, top shock absorber	M10	45 Nm (33.2 lbf ft) <b>Loctite®243™</b>
Nut, swingarm pivot	M12x1	40 Nm (29.5 lbf ft)
Nut, rear wheel spindle	M14x1.5	40 Nm (29.5 lbf ft)
Nut, steering head	M20x1.5	10 Nm (7.4 lbf ft)

## Engine oil, 2-stroke

### Standard/classification

- JASO FD (📖 p. 18)

### Guideline

- Only use high-grade 2-stroke engine oil from a reputable brand.

fully synthetic
-----------------

### Recommended supplier

**MOTOREX®**

- **Cross Power 2T**

## Super unleaded (ROZ 95)

### Standard/classification

- DIN EN 228 (ROZ 95)

### Guideline

- Only use super unleaded fuel that matches or is equivalent to the specified standard.
- Fuel with an ethanol content of up to 10% (E10 fuel) is safe to use.



### Info

Do **not** use fuel containing methanol (e.g., M15, M85, M100) or more than 10% ethanol (e.g., E15, E25, E85, E100).

## Super unleaded (95 octane) mixed with 2-stroke engine oil (1:60)

### Standard/classification

- DIN EN 228
- JASO FD (📖 p. 18) (1:60)

### Mixture ratio

1:60	Engine oil, 2-stroke (📖 p. 16) Super unleaded (ROZ 95) (📖 p. 16)
------	---

### Recommended supplier

**MOTOREX®**

- **Cross Power 2T**

## Long-life grease

Recommended supplier

MOTOREX®

– Bike Grease 2000

### JASO FD

JASO FD is a classification for a 2-stroke engine oil that was specifically developed for the extreme demands of racing. Thanks to first-rate synthetic esters and specially designed additives, superb combustion is achieved even under extreme operating conditions.

**READY TO  
RACE**



3214361en

02/2021



**KTM**

**KTM Sportmotorcycle GmbH**  
5230 Mattighofen/Austria  
**KTM.com**



REG. NO. 12 100 6061

Photo: Mitterbauer/KISKA/KTM