

85 SX

Art. no. 3214362en



Perform the work described in these setup instructions before the vehicle is delivered to the customer.

Read the setup instructions in their entirety before beginning work.

These setup instructions were written to correspond to the latest state of this series. We reserve the right to make changes in the interest of technical advancement without at the same time updating this manual. We shall not provide a description of general workshop methods. Likewise, safety rules that apply in a workshop are not specified here. It is assumed that the work will be performed by a fully trained mechanic.

All specifications contained herein are non-binding. KTM Sportmotorcycle GmbH specifically reserves the right to modify or delete technical specifications, prices, colors, forms, materials, services, designs, equipment, etc., without prior notice and without specifying reasons, to adapt these to local conditions, as well as to stop production of a particular model without prior notice. KTM accepts no liability for delivery options, deviations from figures and descriptions, misprints, and other errors. The models portrayed partly contain special equipment that does not belong to the regular scope of supply.

© 2021 KTM Sportmotorcycle GmbH, Mattighofen Austria

All rights reserved

Reproduction, even in part, as well as copying of all kinds, is permitted only with the express written permission of the copyright owner.



ISO 9001(12 100 6061)

KTM applies quality assurance processes that lead to the highest possible product quality as defined in the ISO 9001 international quality management standard.

Issued by: TÜV Management Service

REG.NO. 12 100 6061

KTM Sportmotorcycle GmbH
Stallhofnerstraße 3
5230 Mattighofen, Austria

This document is valid for the following models:

85 SX 19/16 (F6001U9)

85 SX 17/14 (F6001U8)



1 MEANS OF REPRESENTATION

1.1 Symbols used

The meaning of specific symbols is described below.



Indicates an expected reaction (e.g. of a work step or a function).



Indicates an unexpected reaction (e.g. of a work step or a function).



Indicates a page reference (more information is provided on the specified page).



Indicates information with more details or tips.



Indicates the result of a testing step.



Indicates a voltage measurement.



Indicates a current measurement.



Indicates a resistance measurement.



Indicates the end of an activity including potential rework.

1.2 Formats used

The typographical formats used in this document are explained below.

Proprietary name

Indicates a proprietary name.

Name®

Indicates a protected name.

Brand™

Indicates a brand available on the open market.

Underlined terms

Refer to technical details of the vehicle or indicate technical terms, which are explained in the glossary.

2.1 Unpacking and setting up the vehicle

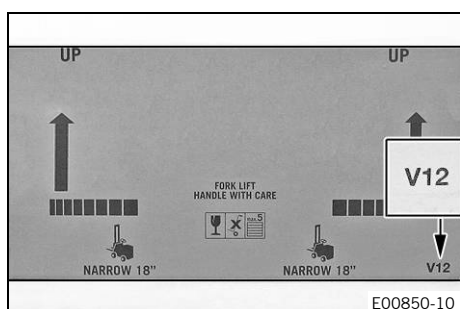

- Open the box.
- Remove the cable tie and wooden frame.

i Info
An assistant prevents the motorcycle from falling over. To avoid damaging the motorcycle during the setup, leave the protective film on the vehicle until you have finished.

- Remove the separate enclosure and unpack it. Check the separate enclosure for completeness.

i Info
The procedure in the event of missing components is described in the customer service manual.

- Have a lift stand available.

Lift stand (78929955100)

- Together with an assistant, take the vehicle off the pallet.
- Position the vehicle on a lift stand.
- Check the vehicle for transport damage.

i Info
The procedure in the event of transport damage is described in the customer service manual.

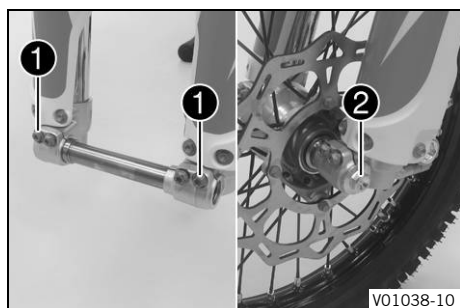
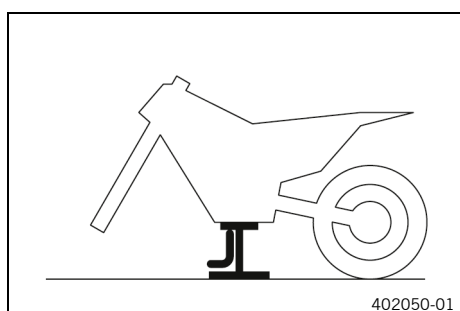

- Loosen screws ① and remove wheel spindle. Jack up the front wheel into the fork, position it, and insert the wheel spindle.
- Mount and tighten the screw of wheel spindle ②.

Guideline

Screw, front wheel spindle	M20x1.5	35 Nm (25.8 lbf ft)
----------------------------	---------	---------------------

- Install front fender. (📖 p. 8)
- Install the start number plate. (📖 p. 8)
- Install the shock absorber. (📖 p. 7)

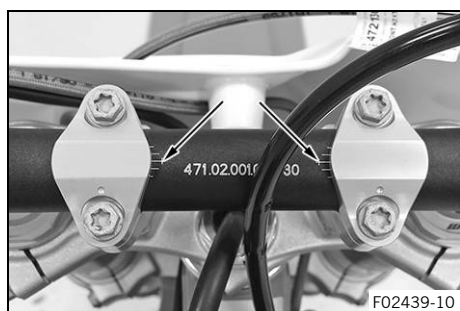

⚠ Warning
Danger of accidents A repaired handlebar poses a safety risk. If the handlebar is bent or straightened, the material becomes fatigued. The handlebar may break as a result.

- Change the handlebar if the handlebar is damaged or bent.

- Position the handlebar.

i Info

Make sure the cables and wiring are positioned correctly.

- Position the handlebar clamps. Mount and tighten the screws evenly.

Guideline

Screw, handlebar clamp	M8	20 Nm (14.8 lbf ft)
------------------------	----	---------------------

i Info

The markings on the handlebar should be at the center of the handlebar clamps.
Keep the installed gap widths equal when tightening.

- Position the handlebar cushion and secure with a cable tie.
- Remove the fuel tank. (📖 p. 9)

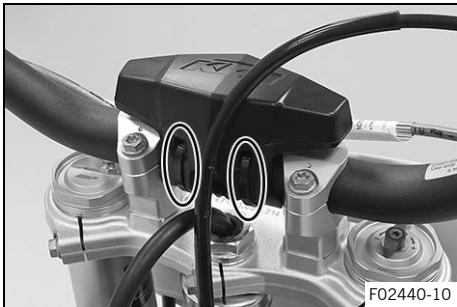

- Mount the service hour counter on the holder.
- Feed the service hour counter cable through the recess **A** and route it under the wiring harness **3** along the frame to the ignition wire.

i Tip

Detach cable holder in the area **B**.

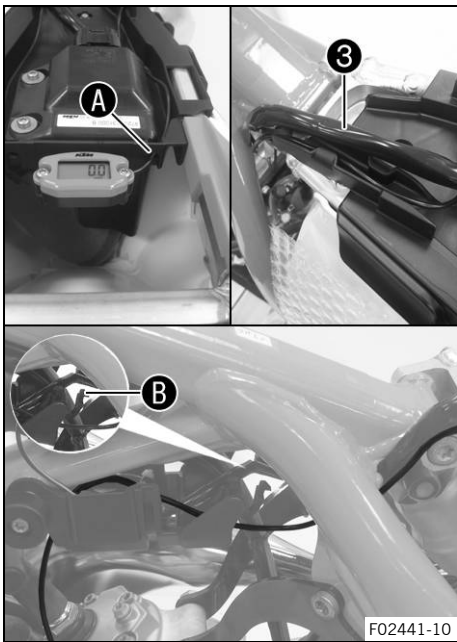

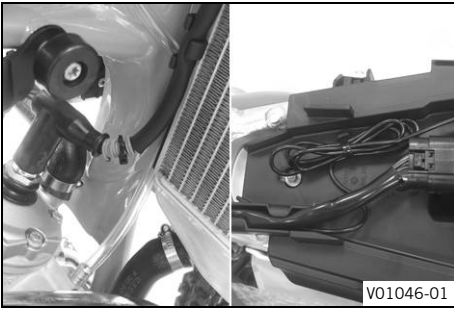

V01046-01

- Wind the cable for the service hour counter around the ignition wire, and secure it using cable ties.
- Attach cable holder. Tie excess cable together with a cable tie.
- Install the fuel tank. (📖 p. 10)

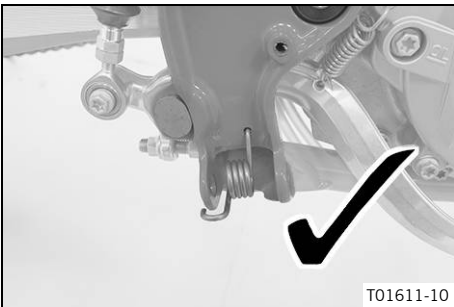

T01611-10

- Position the spring in the hole as shown.

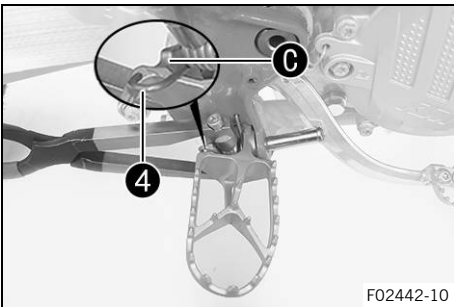

F02442-10

- Position the new footrest and pin.
- ✓ Spring 4 engages in area C.

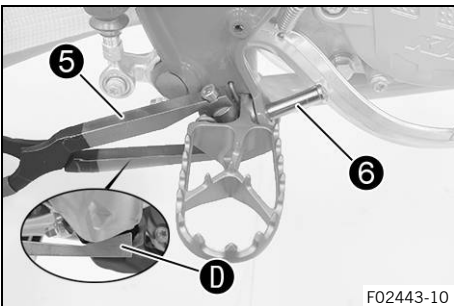

F02443-10

- Press the spring with special tool 5.

Footrest spring plier (79029083000)

- ✓ The special tool is applied to area D on the footrest.
- Mount pin 6.

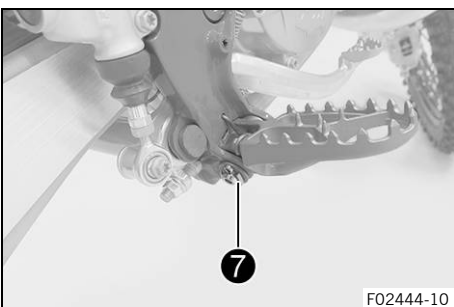

F02444-10

- Mount the washer and split pin 7.
- Repeat these steps on the opposite side.
- Mount the frame protector.

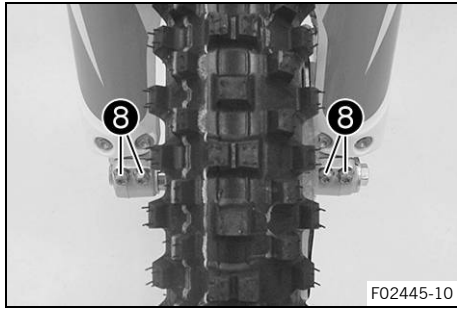

- Remove the motorcycle from the lift stand. (📖 p. 7)
- Operate the hand brake lever several times until the brake linings are seated correctly against the brake disc.
- Activate the front brake and compress the fork a number of times forcefully to align the fork legs.
- Tighten screws ⑧.

Guideline

Screw, fork stub	M8	15 Nm (11.1 lbf ft)
------------------	----	---------------------

- Unpack and mount the **KTM PowerParts** included in the delivery (optional).



Info

Read the accompanying **KTM PowerParts** fitting instructions.

- Attach the stickers included in the scope of supply (optional).
- Refuel. (📖 p. 13)
- Position all controls in their exact positions on the handlebar. Tighten all screws.
- Remove the remaining plastic packaging, corrugated cardboard, and other packaging material.
- Prepare the vehicle according to the specifications in **KTM Dealer.net** for handover to the customer.

3.1 Raising the motorcycle with a lift stand

Note

Danger of damage The parked vehicle can roll away or fall over.

- Park the vehicle on a firm and level surface.

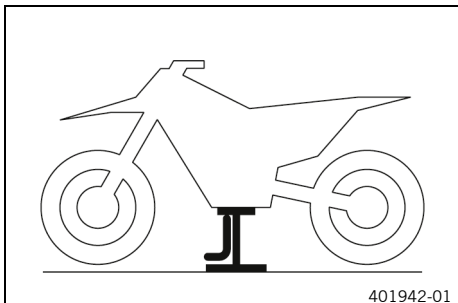

- Raise the motorcycle at the frame underneath the engine.

Lift stand (78929955100)

- ✓ Neither wheel is in contact with the ground.
- Secure the motorcycle against falling over.

3.2 Removing the motorcycle from the lift stand

Note

Danger of damage The parked vehicle can roll away or fall over.

- Park the vehicle on a firm and level surface.

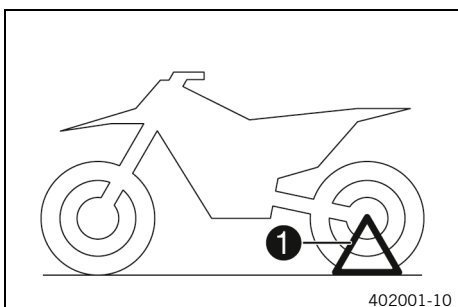

- Remove the motorcycle from the lift stand.
- Remove the lift stand.
- To park the motorcycle, insert plug-in stand ❶ into the left side of the wheel spindle.

i Info Remove the plug-in stand before riding.

3.3 Installing the shock absorber

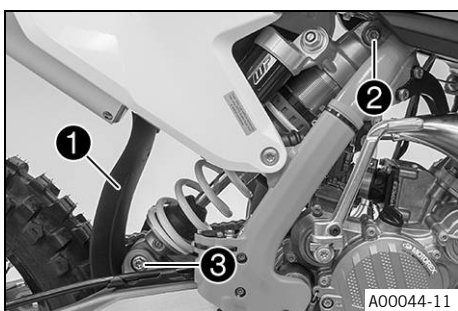

Main work

- Push splash protector ❶ to the side and position the shock absorber. Mount and tighten screw ❷.

Guideline

Screw, top shock absorber	M12	60 Nm (44.3 lbf ft) Loctite®2701™
---------------------------	-----	---------------------------------------------

- Mount and tighten screw ❸.

Guideline

Screw, bottom shock absorber	M12	60 Nm (44.3 lbf ft) Loctite®2701™
------------------------------	-----	---------------------------------------------

- Attach brake line.

Finishing work

- Remove the motorcycle from the lift stand. (🗨 p. 7)

3.4 Installing front fender

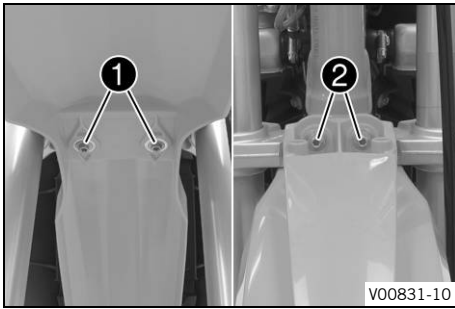

Main work

- Position front fender.
- Mount and tighten screws **1**.

Guideline

Screw, front fender	M6	6 Nm (4.4 lbf ft)
---------------------	----	-------------------

- Mount and tighten screws **2**.

Guideline

Screw, front fender	M6	6 Nm (4.4 lbf ft)
---------------------	----	-------------------

Finishing work

- Install the start number plate. (📖 p. 8)

3.5 Installing the start number plate

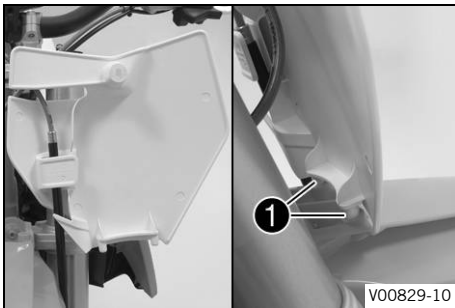

- Attach the start number plate to the brake line.
- Position the start number plate.
- ✓ Holding lugs **1** engage in the fender.

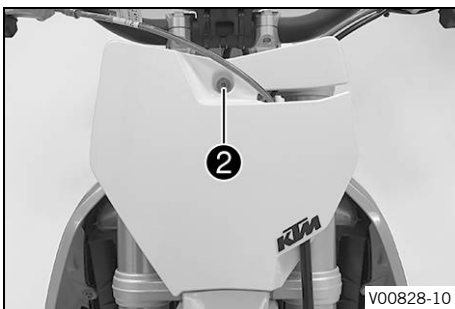

- Mount and tighten screw **2**.

Guideline

Start number plate screw	M6	4 Nm (3 lbf ft)
--------------------------	----	-----------------

3.6 Removing the seat

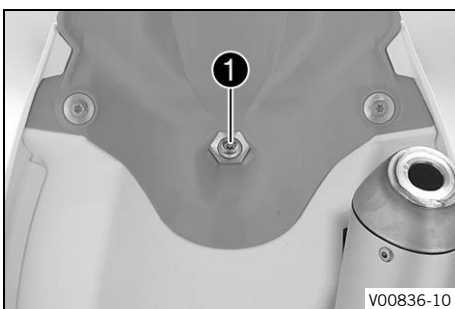

- Remove screw **1**.
- Raise the rear of the seat, pull the seat back, and lift it off.

3.7 Mounting the seat



- Mount the front of the seat on the collar bushing of the fuel tank, lower the seat at the rear, and push the seat forward.
- Make sure that the seat is correctly locked in.

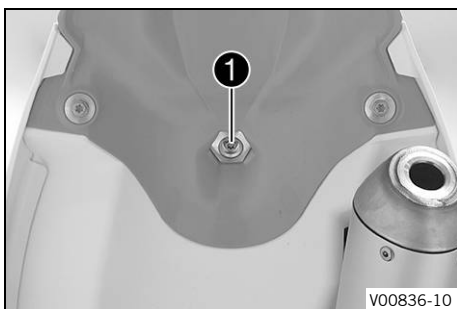

- Mount and tighten screw ❶ of the seat fixing.

Guideline

Remaining screws, chassis	M6	10 Nm (7.4 lbf ft)
---------------------------	----	--------------------

3.8 Removing the fuel tank



Danger

Fire hazard Fuel is highly flammable.

The fuel in the fuel tank expands when warm and can escape if overfilled.

- Do not fuel the vehicle in the vicinity of open flames or lit cigarettes.
- Switch off the engine for refueling.
- Make sure that no fuel is spilled; particularly not on hot parts of the vehicle.
- If any fuel is spilled, wipe it off immediately.
- Observe the specifications for refueling.



Warning

Danger of poisoning Fuel is poisonous and a health hazard.

- Avoid skin, eye and clothing contact with fuel.
- Immediately consult a doctor if you swallow fuel.
- Do not inhale fuel vapors.
- In case of skin contact, rinse the affected area with plenty of water.
- Rinse the eyes thoroughly with water, and consult a doctor in case of fuel contact with the eyes.
- Change your clothing in case of fuel spills on them.
- Keep fuels correctly in a suitable canister, and out of the reach of children.

Preparatory work

- Remove the seat. (📖 p. 8)
- Turn tap handle of the fuel tap to the **OFF** position.

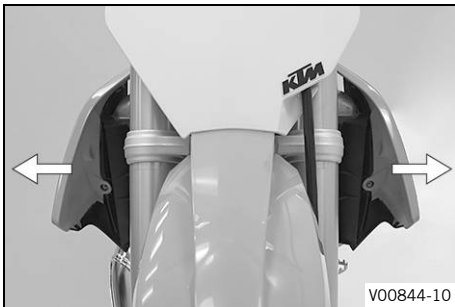
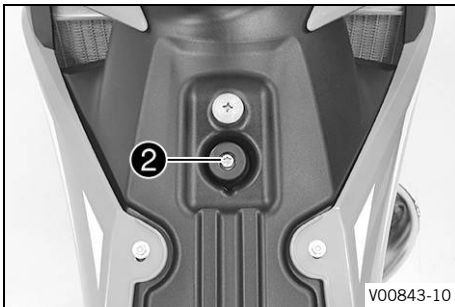
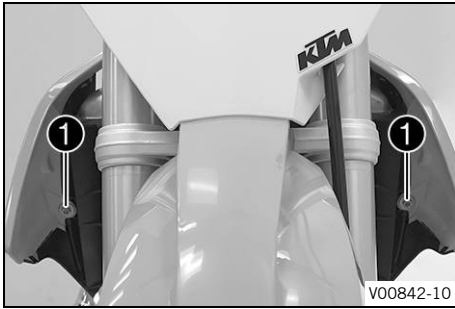

Main work

- Pull off the fuel hose.



Info

Remaining fuel may flow out of the fuel hose.

- Remove screws ①.

- Remove screw ② with the rubber bushing.
- Remove the hose from the fuel tank breather.

- Pull both spoilers off laterally from the radiator bracket and lift off the fuel tank.

3.9 Installing the fuel tank



Danger

Fire hazard Fuel is highly flammable.

The fuel in the fuel tank expands when warm and can escape if overfilled.

- Do not fuel the vehicle in the vicinity of open flames or lit cigarettes.
- Switch off the engine for refueling.
- Make sure that no fuel is spilled; particularly not on hot parts of the vehicle.
- If any fuel is spilled, wipe it off immediately.
- Observe the specifications for refueling.



Warning

Danger of poisoning Fuel is poisonous and a health hazard.

- Avoid skin, eye and clothing contact with fuel.
- Immediately consult a doctor if you swallow fuel.
- Do not inhale fuel vapors.
- In case of skin contact, rinse the affected area with plenty of water.
- Rinse the eyes thoroughly with water, and consult a doctor in case of fuel contact with the eyes.
- Change your clothing in case of fuel spills on them.
- Keep fuels correctly in a suitable canister, and out of the reach of children.

Main work

- Check the throttle cable routing. (📖 p. 11)
- Position the fuel tank and fit the two spoilers to the sides of the radiator mount.
- Make sure that no cables or throttle cables are trapped or damaged.

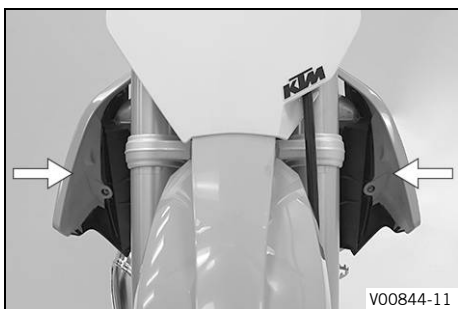

- Mount and tighten screw ❶ with the rubber bushing.

Guideline

Remaining screws, chassis	M6	10 Nm (7.4 lbf ft)
---------------------------	----	--------------------

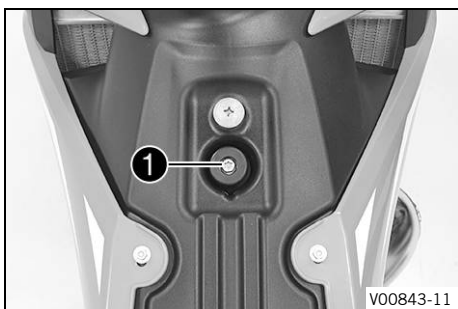

- Mount and tighten screws ❷.

Guideline

Remaining screws, chassis	M6	10 Nm (7.4 lbf ft)
---------------------------	----	--------------------

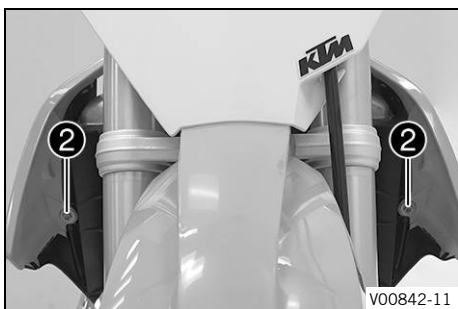

- Mount fuel hose.
- Position the fuel tank breather in the steering stem.

Finishing work

- Mount the seat. (📖 p. 9)

3.10 Checking the throttle cable routing



Warning

Danger of accidents The throttle cable may slip out of the guide if routed incorrectly. The throttle slide will then no longer be closed and the speed can no longer be controlled.

- Make sure that the throttle cable routing and the play in throttle cable complies with the specification.

Preparatory work

- Remove the seat. (📖 p. 8)
- Turn tap handle of the fuel tap to the **OFF** position.
- Remove the fuel tank. (📖 p. 9)

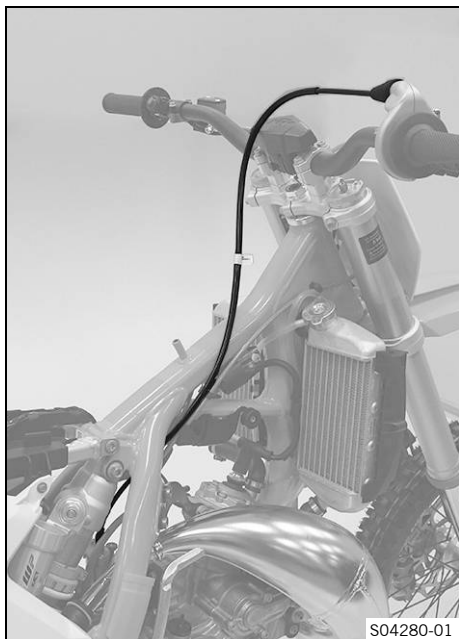

Main work

- Check the throttle cable routing.

The throttle cable must be routed along the back of the handlebar, to the right of the frame, above the fuel tank bracket, and to the carburetor.

- » If the throttle cable is not routed as specified:
 - Correct the throttle cable routing.

Finishing work

- Install the fuel tank. (📖 p. 10)
- Mount the seat. (📖 p. 9)

3.11 Opening the fuel tank filler cap



Danger

Fire hazard Fuel is highly flammable.

The fuel in the fuel tank expands when warm and can escape if overfilled.

- Do not fuel the vehicle in the vicinity of open flames or lit cigarettes.
- Switch off the engine for refueling.
- Make sure that no fuel is spilled; particularly not on hot parts of the vehicle.
- If any fuel is spilled, wipe it off immediately.
- Observe the specifications for refueling.



Warning

Danger of poisoning Fuel is poisonous and a health hazard.

- Avoid skin, eye and clothing contact with fuel.
- Immediately consult a doctor if you swallow fuel.
- Do not inhale fuel vapors.
- In case of skin contact, rinse the affected area with plenty of water.
- Rinse the eyes thoroughly with water, and consult a doctor in case of fuel contact with the eyes.
- Change your clothing in case of fuel spills on them.
- Keep fuels correctly in a suitable canister, and out of the reach of children.



Note

Environmental hazard Improper handling of fuel is a danger to the environment.

- Do not allow fuel to enter the groundwater, the soil, or the sewage system.



- Turn fuel tank filler cap ❶ counterclockwise and lift it off.

3.12 Closing the fuel tank filler cap

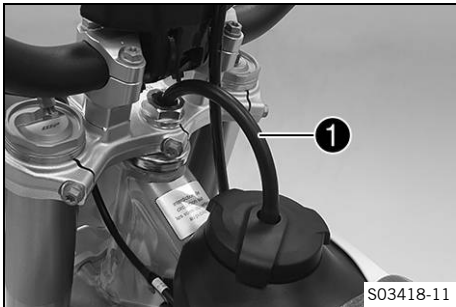

- Mount the fuel tank filler cap and turn it clockwise until the fuel tank is tightly closed.

i Info
Route fuel tank breather hose ❶ without kinks.

3.13 Refueling



Danger

Fire hazard Fuel is highly flammable.

The fuel in the fuel tank expands when warm and can escape if overfilled.

- Do not fuel the vehicle in the vicinity of open flames or lit cigarettes.
- Switch off the engine for refueling.
- Make sure that no fuel is spilled; particularly not on hot parts of the vehicle.
- If any fuel is spilled, wipe it off immediately.
- Observe the specifications for refueling.



Warning

Danger of poisoning Fuel is poisonous and a health hazard.

- Avoid skin, eye and clothing contact with fuel.
- Immediately consult a doctor if you swallow fuel.
- Do not inhale fuel vapors.
- In case of skin contact, rinse the affected area with plenty of water.
- Rinse the eyes thoroughly with water, and consult a doctor in case of fuel contact with the eyes.
- Change your clothing in case of fuel spills on them.



Note

Environmental hazard Improper handling of fuel is a danger to the environment.

- Do not allow fuel to enter the groundwater, the soil, or the sewage system.

- Switch off the engine.
- Open the fuel tank filler cap. (📖 p. 12)

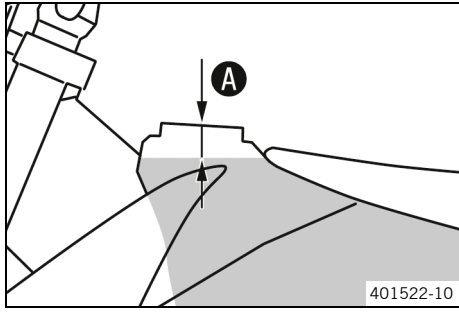

- Fill the fuel tank with fuel up to measurement **A**.

Guideline

Measurement of A	35 mm (1.38 in)
-------------------------	-----------------

Fuel tank capacity, approx.	5.2 l (1.37 US gal)	Super unleaded (98 octane) mixed with 2-stroke engine oil (1:40) (📖 p. 17)
-----------------------------	------------------------	----------------------------------------------------------------------------

Engine oil, 2-stroke (📖 p. 17)

- Close the fuel tank filler cap. (📖 p. 13)



4.1 Chassis tightening torques

Spoke nipple	M4.5	5 Nm (3.7 lbf ft)	
Screw, main silencer	M5	7 Nm (5.2 lbf ft)	
Screw, shock absorber adjusting ring	M5	5 Nm (3.7 lbf ft)	
Pin, front brake	M6	8 Nm (5.9 lbf ft)	
Pin, rear brake	M6	4 Nm (3 lbf ft)	
Remaining nuts, chassis	M6	10 Nm (7.4 lbf ft)	
Remaining screws, chassis	M6	10 Nm (7.4 lbf ft)	
Screw for throttle grip	M6	5 Nm (3.7 lbf ft)	
Screw, ball joint of push rod on foot brake cylinder	M6	10 Nm (7.4 lbf ft)	Loctite®243™
Screw, foot brake cylinder	M6	10 Nm (7.4 lbf ft)	
Screw, front brake disc	M6	14 Nm (10.3 lbf ft)	Loctite®243™
Screw, front fender	M6	6 Nm (4.4 lbf ft)	
Screw, rear brake disc	M6	14 Nm (10.3 lbf ft)	Loctite®243™
Start number plate screw	M6	4 Nm (3 lbf ft)	
Nut, rim lock	M8	10 Nm (7.4 lbf ft)	
Remaining nuts, chassis	M8	25 Nm (18.4 lbf ft)	
Remaining screws, chassis	M8	25 Nm (18.4 lbf ft)	
Screw, bottom triple clamp	M8	15 Nm (11.1 lbf ft)	
Screw, engine brace	M8	25 Nm (18.4 lbf ft)	Loctite®2701™
Screw, fork stub	M8	15 Nm (11.1 lbf ft)	
Screw, front brake caliper	M8	25 Nm (18.4 lbf ft)	Loctite®243™
Screw, handlebar clamp	M8	20 Nm (14.8 lbf ft)	
Screw, rear brake caliper	M8	18 Nm (13.3 lbf ft)	Loctite®243™
Screw, rear sprocket	M8	35 Nm (25.8 lbf ft)	Loctite®2701™
Screw, subframe	M8	35 Nm (25.8 lbf ft)	Loctite®2701™
Screw, top triple clamp	M8	17 Nm (12.5 lbf ft)	
Steering stem clamp screw	M8	20 Nm (14.8 lbf ft)	
Engine carrying screw	M10	45 Nm (33.2 lbf ft)	
Nut, foot brake lever	M10	45 Nm (33.2 lbf ft)	Loctite®243™
Remaining nuts, chassis	M10	45 Nm (33.2 lbf ft)	
Remaining screws, chassis	M10	45 Nm (33.2 lbf ft)	
Screw, handlebar support	M10	40 Nm (29.5 lbf ft)	Loctite®243™
Screw, bottom shock absorber	M12	60 Nm (44.3 lbf ft)	Loctite®2701™
Screw, top shock absorber	M12	60 Nm (44.3 lbf ft)	Loctite®2701™

4 TECHNICAL DATA

Nut, seat fixing	M12x1	20 Nm (14.8 lbf ft)
Nut, swingarm pivot	M14x1.5	75 Nm (55.3 lbf ft)
Nut, rear wheel spindle	M20x1.5	80 Nm (59 lbf ft)
Nut, steering stem	M20x1.5	10 Nm (7.4 lbf ft)
Screw, front wheel spindle	M20x1.5	35 Nm (25.8 lbf ft)

Engine oil, 2-stroke**Standard/classification**

- JASO FD (📖 p. 18)

Guideline

- Only use high-grade 2-stroke engine oil from a reputable brand.

fully synthetic

Recommended supplier**MOTOREX®**

- Cross Power 2T

Super unleaded (ROZ 98 / RON 98 / PON 94)**Standard/classification**

- DIN EN 228 (ROZ 98 / RON 98 / PON 94)

Super unleaded (98 octane) mixed with 2-stroke engine oil (1:40)**Standard/classification**

- DIN EN 228
- JASO FD (📖 p. 18) (1:40)

Mixture ratio

1:40	Engine oil, 2-stroke (📖 p. 17) Super unleaded (ROZ 98 / RON 98 / PON 94) (📖 p. 17)
------	---------------------------------------------------------------------------------------

Recommended supplier**MOTOREX®**

- Cross Power 2T

JASO FD

JASO FD is a classification for a 2-stroke engine oil that was specifically developed for the extreme demands of racing. Thanks to first-rate synthetic esters and specially designed additives, superb combustion is achieved even under extreme operating conditions.

**READY TO
RACE**



3214362en

02/2021



KTM Sportmotorcycle GmbH
5230 Mattighofen/Austria
KTM.com



REG. NO. 12 100 6061

Photo: Mitterbauer/KISKA/KTM