

**450 SX-F  
450 XC-F  
450 SX-F FACTORY EDITION**

Art. no. 3214370en





Perform the work described in these setup instructions before the vehicle is delivered to the customer.

Read the setup instructions in their entirety before beginning work.

These setup instructions were written to correspond to the latest state of this series. We reserve the right to make changes in the interest of technical advancement without at the same time updating this manual. We shall not provide a description of general workshop methods. Likewise, safety rules that apply in a workshop are not specified here. It is assumed that the work will be performed by a fully trained mechanic.

All specifications contained herein are non-binding. KTM Sportmotorcycle GmbH specifically reserves the right to modify or delete technical specifications, prices, colors, forms, materials, services, designs, equipment, etc., without prior notice and without specifying reasons, to adapt these to local conditions, as well as to stop production of a particular model without prior notice. KTM accepts no liability for delivery options, deviations from figures and descriptions, misprints, and other errors. The models portrayed partly contain special equipment that does not belong to the regular scope of supply.

© 2021 KTM Sportmotorcycle GmbH, Mattighofen Austria

All rights reserved

Reproduction, even in part, as well as copying of all kinds, is permitted only with the express written permission of the copyright owner.



ISO 9001(12 100 6061)

KTM applies quality assurance processes that lead to the highest possible product quality as defined in the ISO 9001 international quality management standard.

Issued by: TÜV Management Service

REG.NO. 12 100 6061

KTM Sportmotorcycle GmbH  
Stallhofnerstraße 3  
5230 Mattighofen, Austria

This document is valid for the following models:

450 SX-F EU (F8401U5)

450 SX-F US (F8475U5)

450 XC-F US (F8475U0)

450 SX-F FACTORY EDITION US (F8475U1)



# 1 MEANS OF REPRESENTATION

## 1.1 Symbols used

The meaning of specific symbols is described below.



Indicates an expected reaction (e.g. of a work step or a function).



Indicates an unexpected reaction (e.g. of a work step or a function).



Indicates a page reference (more information is provided on the specified page).



Indicates information with more details or tips.



Indicates the result of a testing step.



Indicates a voltage measurement.



Indicates a current measurement.



Indicates a resistance measurement.



Indicates the end of an activity including potential rework.

## 1.2 Formats used

The typographical formats used in this document are explained below.

**Proprietary name**

Indicates a proprietary name.

**Name®**

Indicates a protected name.

**Brand™**

Indicates a brand available on the open market.

**Underlined terms**

Refer to technical details of the vehicle or indicate technical terms, which are explained in the glossary.

## 2.1 Transport mode

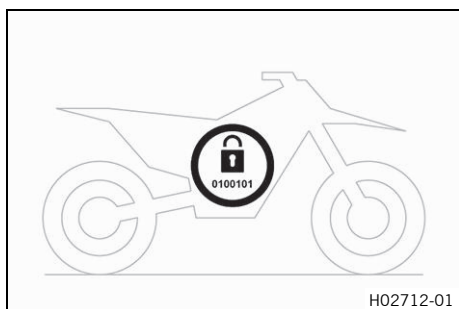

This vehicle was blocked for transport in the software. To operate the vehicle, the vehicle electronics must be enabled. This process is conducted during initial setup in KTM Dealer.net. Enabling ensures that the initial setup in KTM Dealer.net is documented.

Enabling can be performed either temporarily, e.g. for a test ride, or permanently for vehicle handover.

### **i** Info

Make sure that the vehicle is permanently enabled before handing it over to the customer.

## 2.2 Diagnostics connector

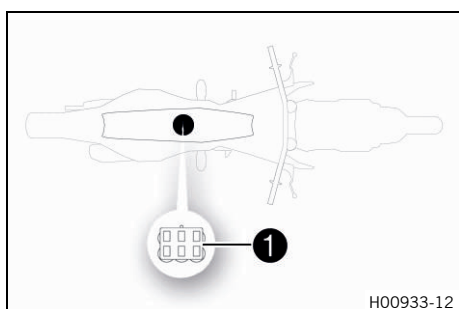

Diagnostics connector 1 is located under the seat.

## 2.3 Unpacking and setting up the vehicle

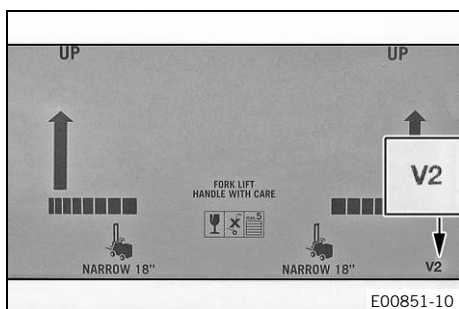

### Package 2

- Remove the box and the plastic packaging.

### **i** Info

To avoid damaging the motorcycle during the setup, leave the protective film on the vehicle until you have finished.

- Remove the separate enclosure and unpack it. Check that the scope of supply is complete on the basis of the enclosed packing list.

### **i** Info

The procedure in the event of missing components is described in the customer service manual.

- Remove the cable ties on the rear wheel, take off the front wheel and the fender.
- Have a lift stand available.

Lift stand (78129955100)

- Carefully loosen and remove the tension belt of the footrest mount.

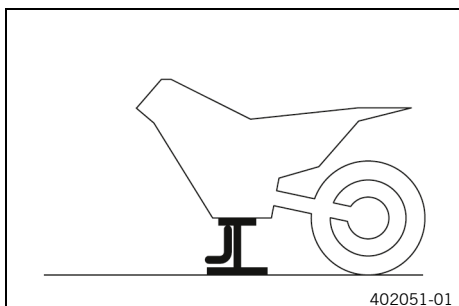
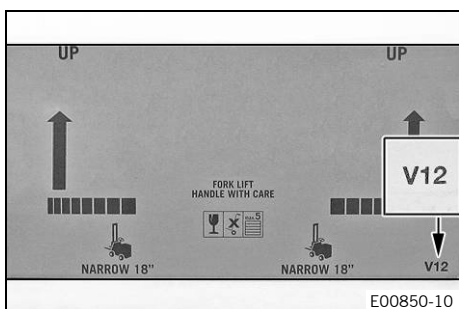
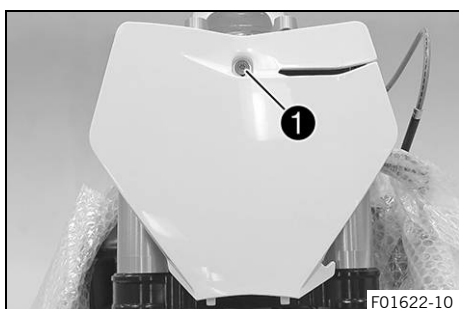
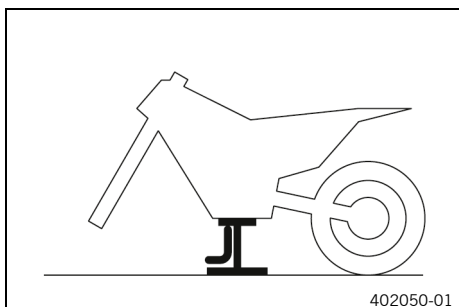

**i Info**  
An assistant prevents the motorcycle from falling over.

- Together with an assistant, take the vehicle off the pallet.
- Position the vehicle on a lift stand.
- Check the vehicle for transport damage.

**i Info**  
The procedure in the event of transport damage is described in the customer service manual.

- Remove screw **1** and take off the start number plate.

### Package 12

- Remove the box and the plastic packaging.

**i Info**  
An assistant prevents the motorcycle from falling over.  
To avoid damaging the motorcycle during the setup, leave the protective film on the vehicle until you have finished.

- Remove the separate enclosure and unpack it. Check that the scope of supply is complete on the basis of the enclosed packing list.

**i Info**  
The procedure in the event of missing components is described in the customer service manual.

- Have a lift stand available.

Lift stand (78129955100)

- Together with an assistant, take the vehicle off the pallet.
- Position the vehicle on a lift stand.
- Check the vehicle for transport damage.

**i Info**  
The procedure in the event of transport damage is described in the customer service manual.

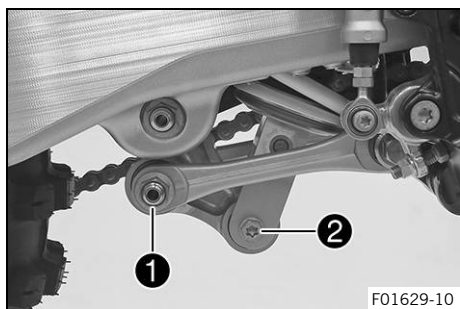

- Remove the cardboard from around the shock absorber.
- Position the angle lever and linkage lever.
- Mount and tighten fitting **1**.

Guideline

Nut, linkage lever on angle lever	M14x1.5	60 Nm (44.3 lbf ft)
-----------------------------------	---------	---------------------

- Mount and tighten screw **2**.

Guideline

Screw, bottom shock absorber	M10	60 Nm (44.3 lbf ft) <b>Loctite®2701™</b>
------------------------------	-----	---



### Info

Raise the wheel slightly to be able to mount the screw more easily.



- Route the clutch line with the clutch master cylinder toward the front between the upper and lower triple clamps.

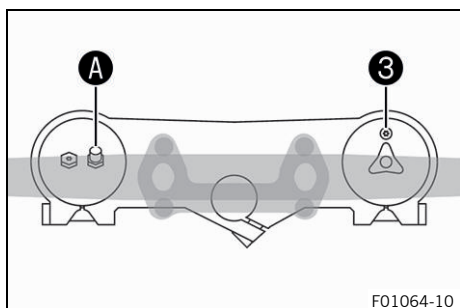

- Position the fork legs and tighten the screws of the triple clamp.

Guideline

Screw, top triple clamp	M8	17 Nm (12.5 lbf ft)
Screw, bottom triple clamp	M8	12 Nm (8.9 lbf ft)

- ✓ Air bleeder screw **3** of the right fork leg is positioned to the front.
- ✓ Valve **A** of the left fork leg faces the front.



### Info

Grooves are milled into the side of the upper end of the fork legs. The second milled groove (from the top) must be flush with the upper edge of the upper triple clamp.

The air suspension is located in the left fork leg. The pressure and rebound damping is located in the right fork leg.

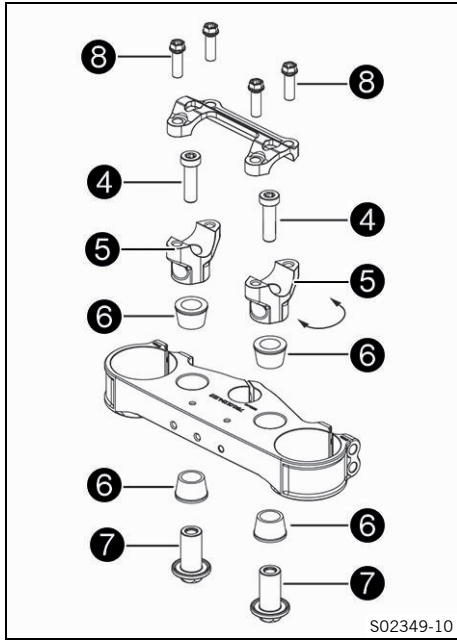

- Remove screws ④. Take off handlebar supports ⑤.
- Position rubber bushings ⑥ and push through nuts ⑦ from below.
- Place handlebar supports in required position.



**Info**

The handlebar supports are longer and higher on one side.  
Position the left and right handlebar supports evenly.

- Mount and tighten screws ④.

Guideline

Screw, handlebar support	M10	40 Nm (29.5 lbf ft) <b>Loctite®243™</b>
--------------------------	-----	--

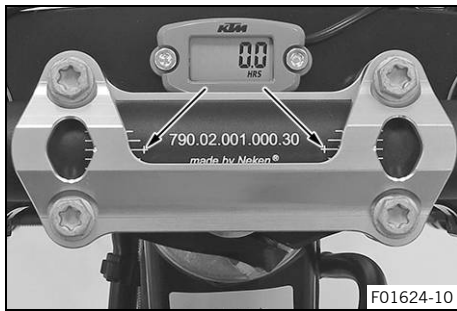

- Remove cable ties on the side cover and remove film from the handlebar.



**Warning**

**Danger of accidents** A repaired handlebar poses a safety risk.

If the handlebar is bent or straightened, the material becomes fatigued. The handlebar may break as a result.

- Change the handlebar if the handlebar is damaged or bent.

- Position the handlebar.



**Info**

Make sure the cables and wiring are positioned correctly.  
Do not kink the cables and lines.

- Position the handlebar clamp.
- Mount screws ⑧, but do not tighten yet.
- First bolt the handlebar clamp with screws ⑧ onto the longer, higher side of the handlebar supports so that both parts touch.
- Tighten screws ⑧ evenly.

Guideline

Screw, handlebar clamp	M8	20 Nm (14.8 lbf ft)
------------------------	----	---------------------



**Info**

The markings on the handlebar should be at the center of the handlebar clamps.



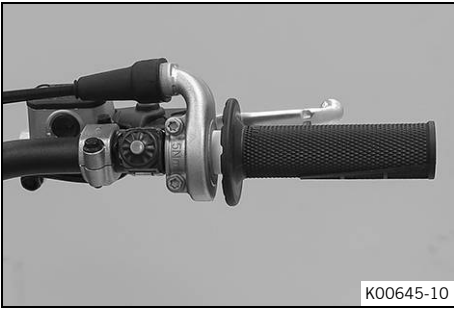

- Position the controls on the right half of the handlebar.

Guideline

Screw, throttle grip	M6	5 Nm (3.7 lbf ft)
----------------------	----	-------------------



- Position the controls on the left handlebar half.

Guideline

Screw, fixed grip	M4	5 Nm (3.7 lbf ft) <b>Loctite®243™</b>
-------------------	----	--

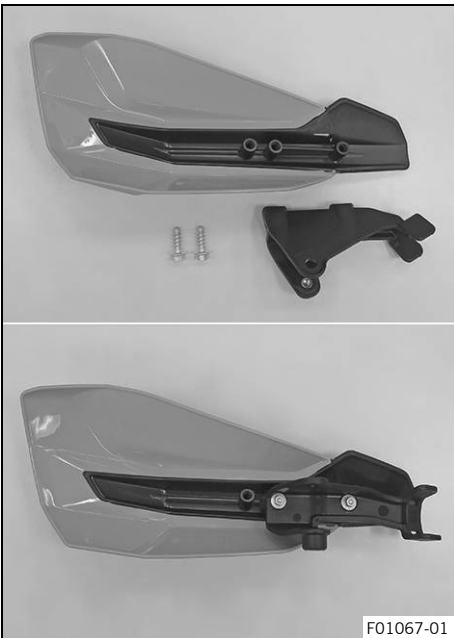

**(XC-F US)**

- Preassemble the hand guards on the left and right.



- Mount the left hand guard.
- Mount the right hand guard.

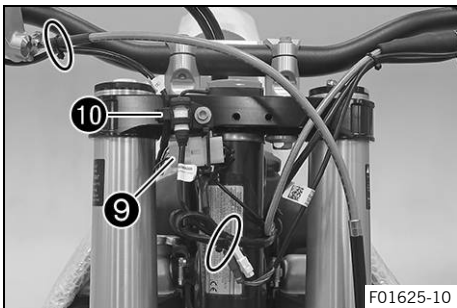

### (all SX-F models)

- Join plug-in connector 9.
- Attach cable in the indicator lamp bracket 10.
- Route the cables without tension and secure with the cable ties.

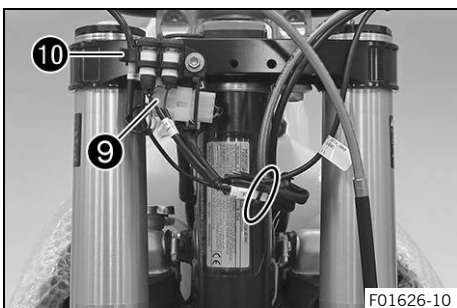

### (XC-F US)

- Join plug-in connector 9.
- Attach cable in the indicator lamp bracket 10.
- Route the cables without tension and secure with the cable ties.
- Install the start number plate. (📖 p. 17)



- Mount the handlebar cushion.
- Install front fender. (📖 p. 16)



F02598-01

**(Factory Edition)**

- Mount the Factory-Start.



**Info**

Read the accompanying **KTM PowerParts** instructions.

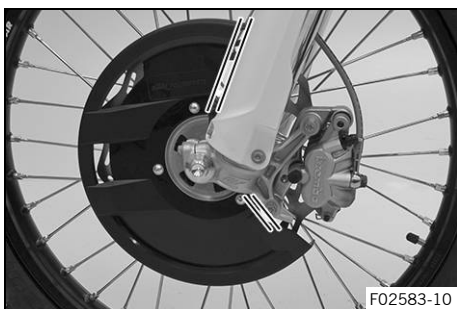

F02583-10

**(Factory Edition)**

- Mount the brake disc guard.



**Info**

Read the accompanying **KTM PowerParts** instructions.

Align the brake disc guard so that the distances are the same size.

- Install the front wheel. (📖 p. 15)



F01628-10

**Condition**

Target market excluding USA

- Apply **WARNING** sticker to the rear fender.



**Info**

The **WARNING** sticker must not be applied together with the **COMPETITION ONLY** sticker.

**Condition**

USA target market

- Do not apply the **WARNING** sticker.



D00674-10

**Left and right footrest (all SX-F models)**

- Position the new footrest and pin.



**Info**

Only insert the pin to the extent that the spring can still be mounted.

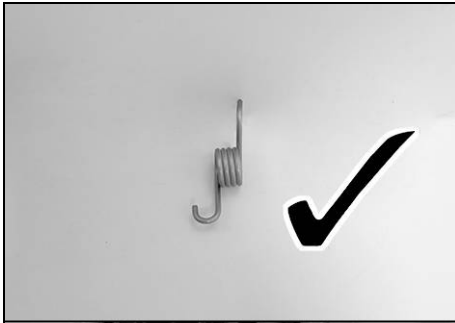

- Position spring as shown.
- ✓ Spring **B** engages in area **C**.

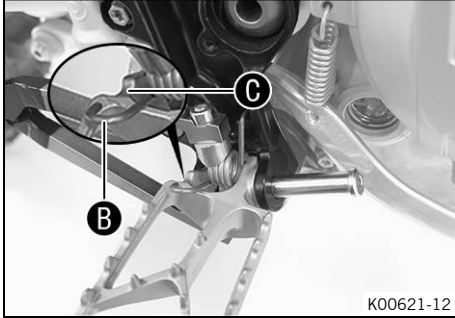

K00621-12

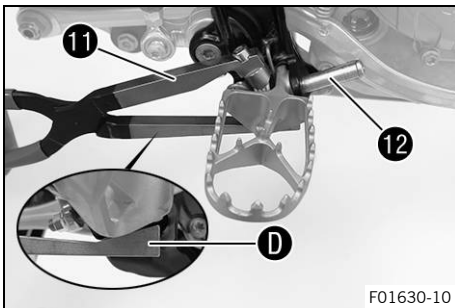

F01630-10

- Press the spring with special tool **11**.

Footrest spring plier (79029083000)

- ✓ The special tool is applied to area **D** on the footrest.
- Mount pin **12**.

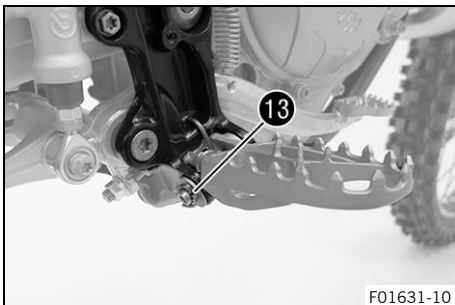

F01631-10

- Mount the washer and splint **13**.
- Repeat these steps on the opposite side.

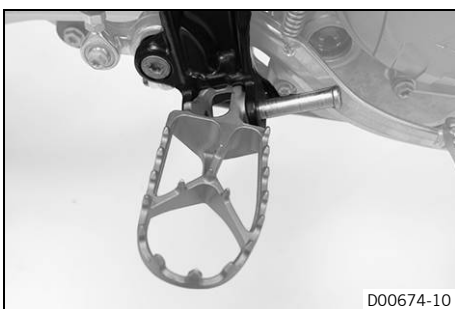

D00674-10

### Right footrest (XC-F US)

- Position the right footrest and pin.



#### Info

Only insert the pin to the extent that the spring can still be mounted.

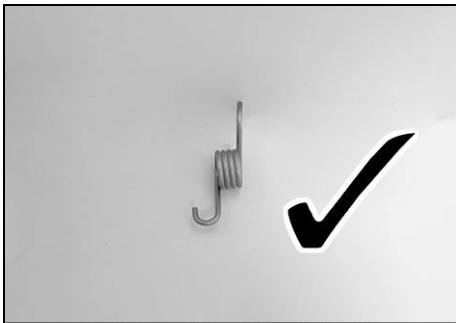

- Position spring as shown.
- ✓ Spring **B** engages in area **C**.

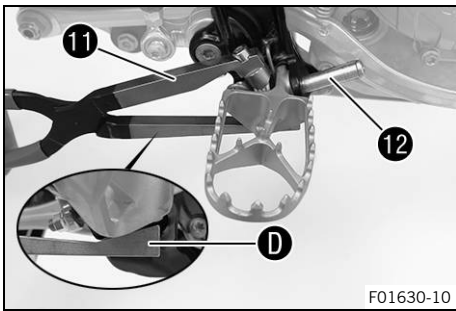
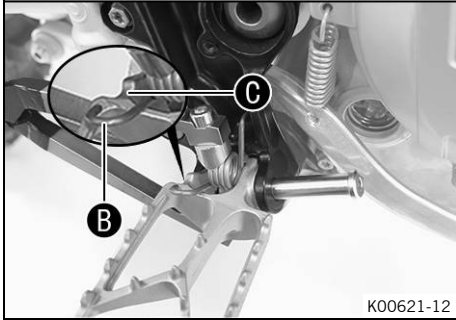

- Press the spring with special tool **11**.
- Footrest spring plier (79029083000)
- ✓ The special tool is applied to area **D** on the footrest.
  - Mount pin **12**.

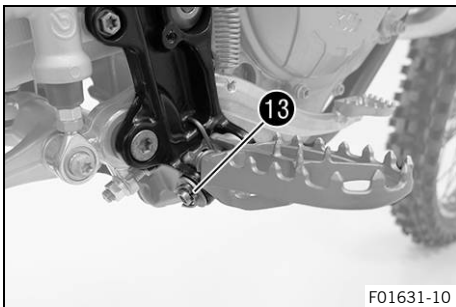

- Mount the washer and splint **13**.

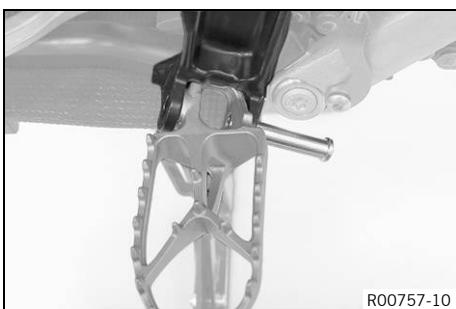

**Left footrest (XC-F US)**

- Position the left footrest and pin.



**Info**

Only insert the pin to the extent that the spring can still be mounted.

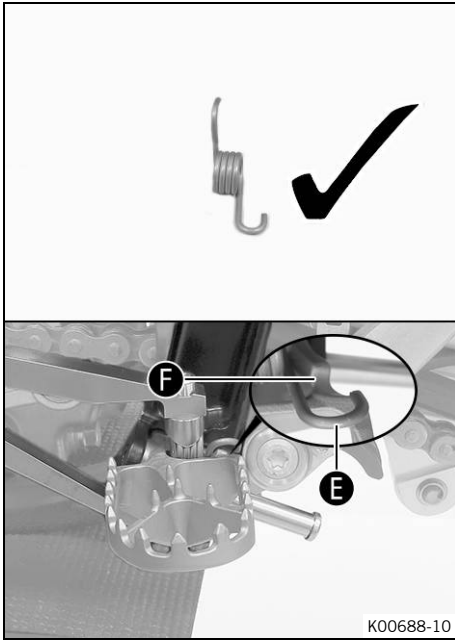

- Position spring as shown.
- ✓ Spring **E** engages in area **F**.

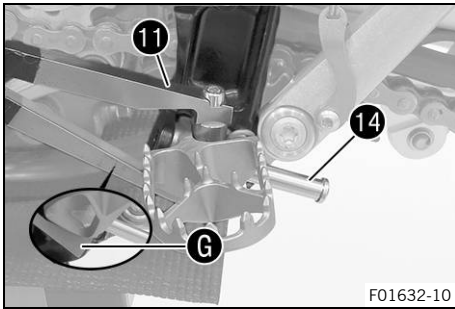

- Press the spring with special tool **11**.
- |                                     |
|-------------------------------------|
| Footrest spring plier (79029083000) |
|-------------------------------------|
- ✓ The special tool is applied to area **G** on the footrest.
  - Mount pin **14**.

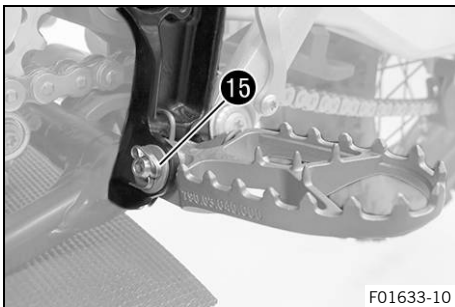

- Mount the washer and splint **15**.

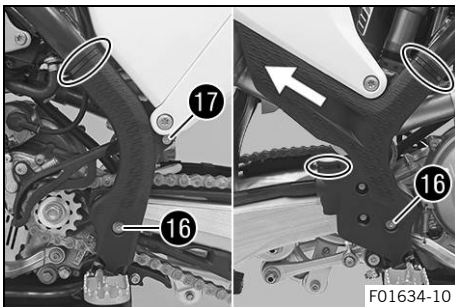

- Position the left frame protector.
- Insert the right frame protector from below and push it to the rear.
- Mount and tighten screws **16** with washers.

Guideline

Screw, frame protector	M5	3 Nm (2.2 lbf ft)
------------------------	----	-------------------

- Mount and tighten screw **17**.

Guideline

Screw, frame protector	M5	3 Nm (2.2 lbf ft)
------------------------	----	-------------------

- Mount the cable ties.

## (Factory Edition)

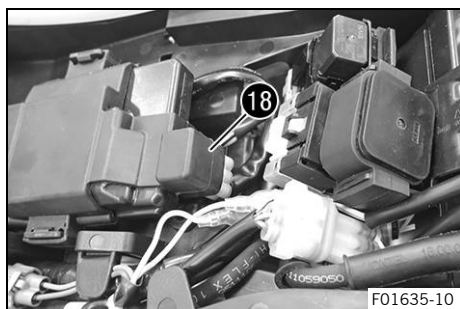

- Install the engine guard. (📖 p. 20)
- Remove the seat. (📖 p. 17)
- Remove the air filter box cover. (📖 p. 18)
- Route the diagnostics connector and the positive cable upwards towards the 12-V battery.
- Position diagnostics connector in holder 18.
- Install the air filter box cover. (📖 p. 19)

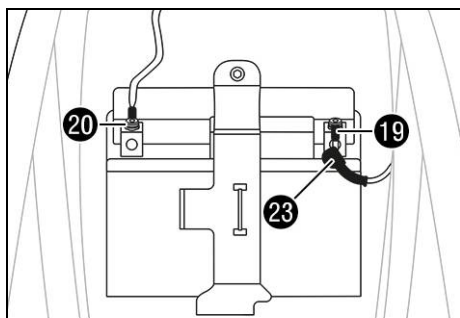

- Connect positive cable 19 to the 12-V battery.

### Guideline

Screw, battery terminal	M5	2.5 Nm (1.84 lbf ft)
-------------------------	----	-------------------------

- Connect negative cable 20 to the 12 V battery.

### Guideline

Screw, battery terminal	M5	2.5 Nm (1.84 lbf ft)
-------------------------	----	-------------------------

Contact disks **H** must be mounted under screws **21** and cable sockets **22** with the claws toward the battery terminal.

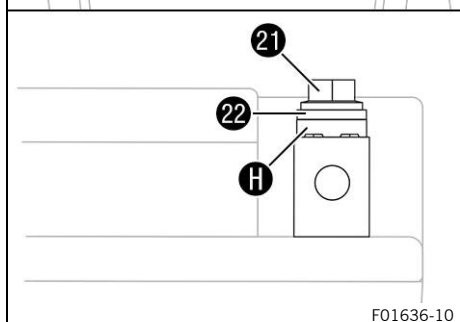

- Slide positive terminal cover 23 over the positive terminal.
- Charge the 12-V battery. (📖 p. 20)
- Unpack and mount the **KTM PowerParts** included in the delivery (optional).

### **i** Info

Read the accompanying **KTM PowerParts** fitting instructions.

- Attach the stickers included in the scope of supply (optional).
- Refuel. (📖 p. 24)
- Position all controls in their exact positions on the handlebar. Tighten all screws.
- Remove the remaining film, padding, the corrugated cardboard, and the other packaging material.
- Prepare the vehicle according to the specifications in **KTM Dealer.net** for handover to the customer.

### **i** Info

Transport mode must be deactivated to be able to start the motorcycle.

### 3.1 Raising the motorcycle with a lift stand

#### Note

**Material damage** The vehicle may be damaged by incorrect procedure when parking. Significant damage may be caused if the vehicle rolls away or falls over. The components for parking the vehicle are designed only for the weight of the vehicle.

- Park the vehicle on a firm and level surface.
- Ensure that nobody sits on the vehicle when the vehicle is parked on a stand.

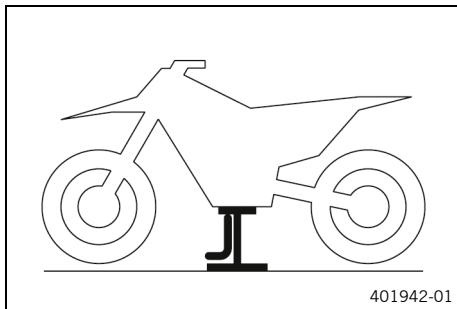

#### (All SX-F standard models)

- Remove the plug-in stand and lift up the motorcycle by the frame underneath the engine.

Lift stand (78129955100)

- ✓ Neither wheel is in contact with the ground.

#### (Factory Edition)

- Remove the plug-in stand and lift up the motorcycle by the motor guard underneath the engine.

Lift stand (78129955100)

- ✓ Neither wheel is in contact with the ground.

#### (XC-F US)

- Fold in the side stand and raise the motorcycle at the frame underneath the engine.

Lift stand (78129955100)

- ✓ Neither wheel is in contact with the ground.

- Secure the motorcycle against falling over.

### 3.2 Removing the motorcycle from the lift stand

#### Note

**Material damage** The vehicle may be damaged by incorrect procedure when parking. Significant damage may be caused if the vehicle rolls away or falls over. The components for parking the vehicle are designed only for the weight of the vehicle.

- Park the vehicle on a firm and level surface.
- Ensure that nobody sits on the vehicle when the vehicle is parked on a stand.

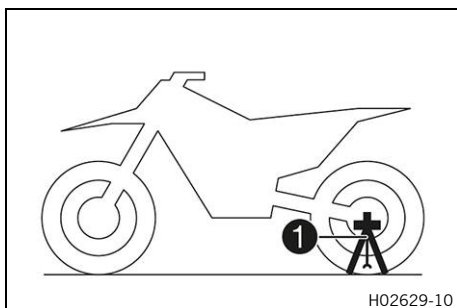

#### (all SX-F models)

- Remove the motorcycle from the lift stand.
- Remove the lift stand.
- To park the motorcycle, insert plug-in stand ① into the left side of the wheel spindle.

Plug-in stand (79029094000)



#### Info

The plug-in stand is included. Remove the plug-in stand before riding.



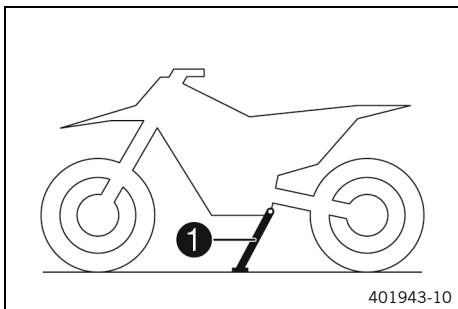

**(XC-F US)**

- Remove the motorcycle from the lift stand.
- Remove the lift stand.
- To park the motorcycle, press side stand **1** to the ground with your foot and lean the motorcycle on it.

**i Info**  
When you are riding, the side stand must be folded up and secured with rubber strap.

**3.3 Installing the front wheel**

**Warning**  
**Danger of accidents** Oil or grease on the brake discs reduces the braking effect.

- Always keep the brake discs free of oil and grease.
- Clean the brake discs with brake cleaner when necessary.

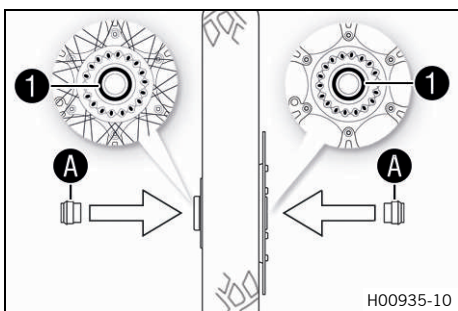

**(SX-F EU/US, XC-F US)**

- Check the wheel bearing for damage and wear.
  - » If the wheel bearing is damaged or worn:
    - Change front wheel bearing.
- Clean and grease shaft seal rings **1** and contact surfaces **A** of the spacers.

Long-life grease (📖 p. 29)

- Insert the spacers.
- Clean and grease the wheel spindle.

Long-life grease (📖 p. 29)

- Position the front wheel and insert the wheel spindle.
  - ✓ The brake linings are correctly positioned.

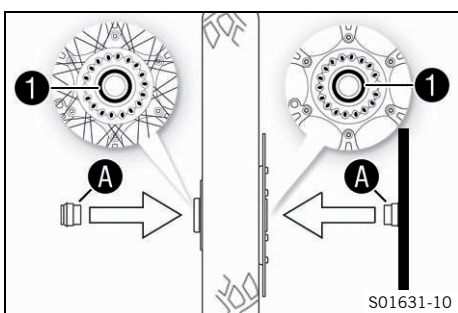

**(Factory Edition)**

- Check the wheel bearing for damage and wear.
  - » If the wheel bearing is damaged or worn:
    - Change front wheel bearing.
- Clean and grease shaft seal rings **1** and contact surfaces **A** of the spacers.

Long-life grease (📖 p. 29)

- Insert the spacer and brake disc guard.
- Clean and grease the wheel spindle.

Long-life grease (📖 p. 29)

- Position the front wheel and insert the wheel spindle.
  - ✓ The brake linings are correctly positioned.

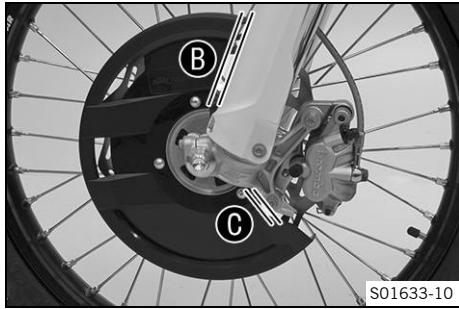

S01633-10

- Align the brake disc guard so that distance **B** and **C** are equal in size.

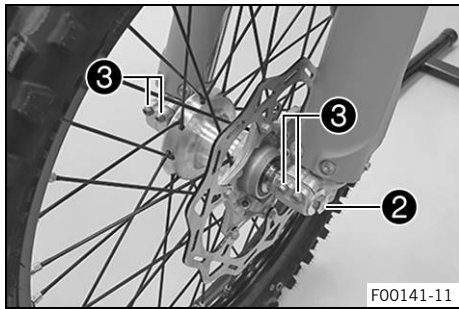

F00141-11

- Mount and tighten screw **2**.

Guideline

Screw, front wheel spindle	M20x1.5	35 Nm (25.8 lbf ft)
----------------------------	---------	---------------------

- Operate the hand brake lever several times until the brake linings are seated correctly against the brake disc.
- Remove the motorcycle from the lift stand. (📖 p. 14)
- Operate the front brake and compress the fork a few times firmly.

✓ The fork legs straighten.

- Tighten screws **3**.

Guideline

Screw, fork stub	M8	15 Nm (11.1 lbf ft)
------------------	----	---------------------

## 3.4 Installing front fender

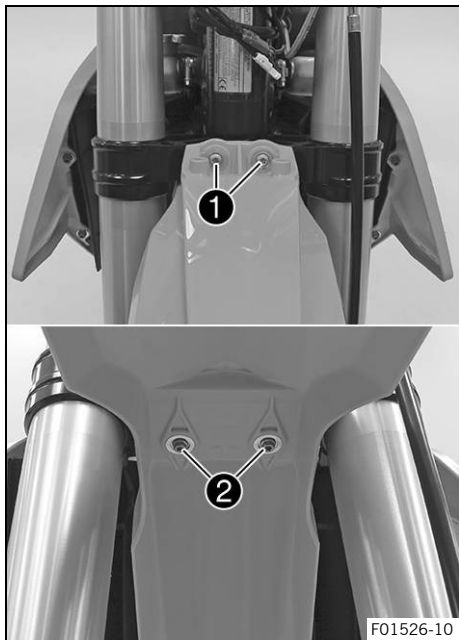

F01526-10

### Main work

- Position front fender. Mount and tighten screws **1** and **2**.

Guideline

Remaining screws, chassis	M6	10 Nm (7.4 lbf ft)
---------------------------	----	--------------------

### Finishing work

- Install the start number plate. (📖 p. 17)

### 3.5 Installing the start number plate

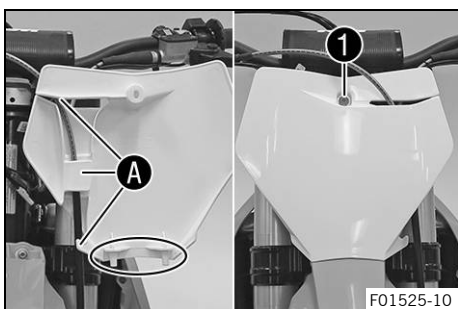

- Position the brake line in holders **A** on the start number plate.
- Position the start number plate. Mount and tighten screw **1**.
- ✓ The holding lugs engage in the fender.

### 3.6 Removing the seat



#### Caution

**Danger of burns** The voltage regulator gets very hot when the vehicle is driven.

- Allow the voltage regulator to cool down before performing any work.

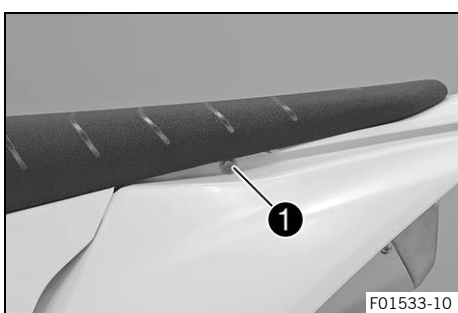

- Remove screw **1**.

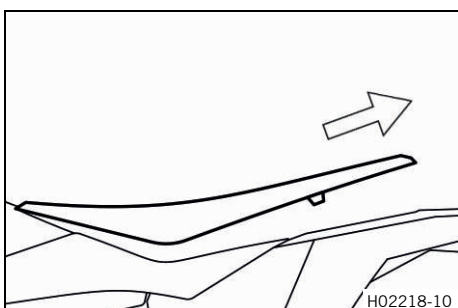

- Raise the rear of the seat, pull the seat back, and lift it off.

### 3.7 Mounting the seat

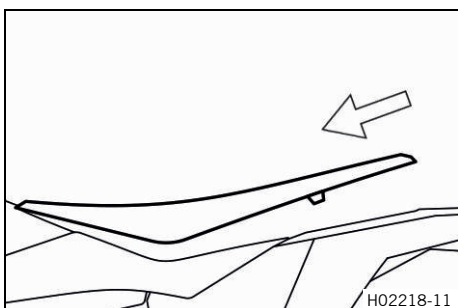

- Mount the front of the seat on the collar bushing of the fuel tank, lower the seat at the rear, and push the seat forward.
- Make sure the seat is latched in place correctly.

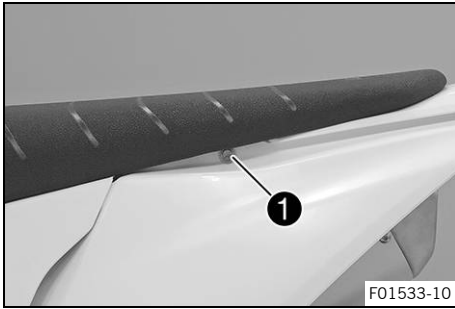

- Mount and tighten screw 1.

Guideline

Remaining screws, chassis	M6	10 Nm (7.4 lbf ft)
---------------------------	----	--------------------

## 3.8 Removing the air filter box cover

### Condition

The air filter box cover is secured.

- Remove the seat. (📖 p. 17)
- Remove screw 1.

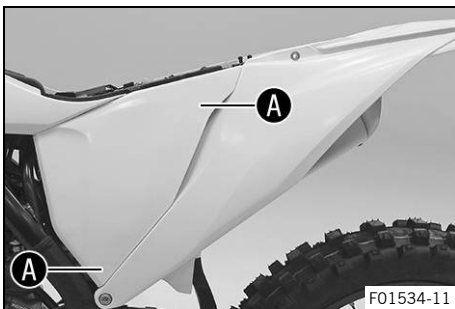
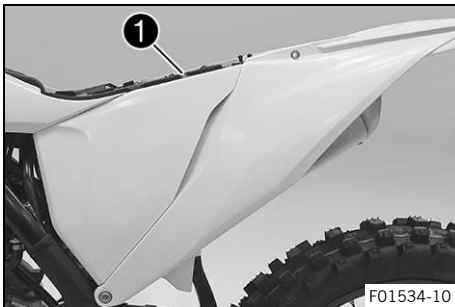

- Pull off the air filter box cover in area A sideways and take off toward the front.

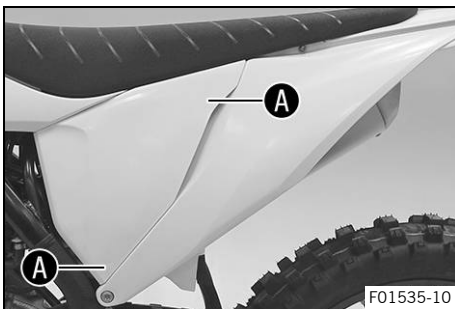

### Condition

The air filter box cover is not secured.

- Pull off the air filter box cover in area A laterally and take it off at the front.

3.9 Installing the air filter box cover

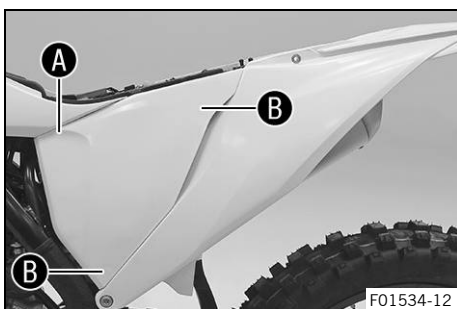

(all SX-F models)

Condition

The air filter box cover is secured.

- Insert the air filter box cover in area **A** and clip it into area **B**.

**i** Info

An air filter box cover with openings for greater airflow and a more direct response is included.

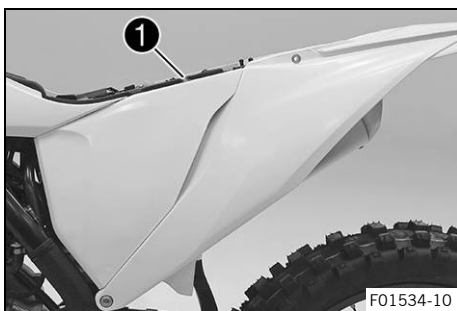

- Mount and tighten screw **1**.

Guideline

Screw, air filter box cover	<b>EJOT PT®</b> K60x20-Z	3 Nm (2.2 lbf ft)
-----------------------------	-----------------------------	-------------------

- Mount the seat. (📖 p. 17)

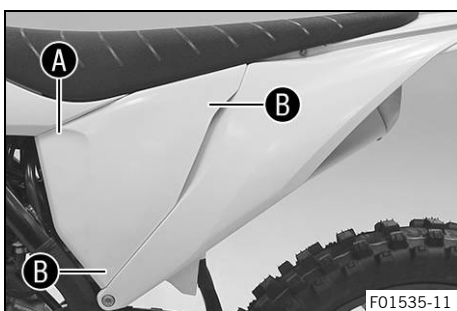

Condition

The air filter box cover is not secured.

- Insert the air filter box cover in area **A** and clip it into area **B**.

**i** Info

An air filter box cover with openings for greater airflow and a more direct response is included.

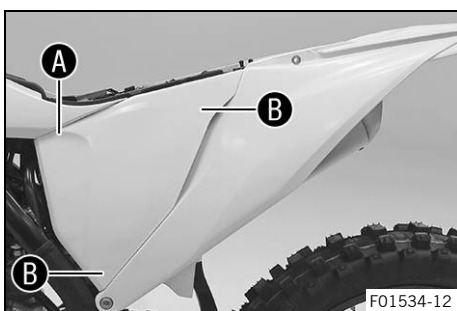

(XC-F US)

Condition

The air filter box cover is secured.

- Insert the air filter box cover in area **A** and clip it into area **B**.

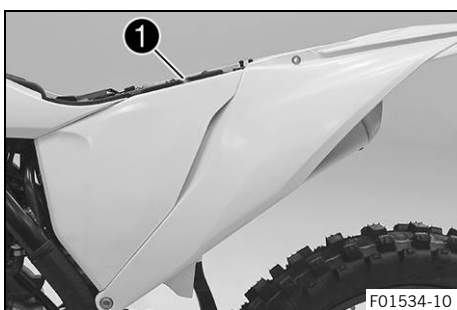

- Mount and tighten screw **1**.

Guideline

Screw, air filter box cover	<b>EJOT PT®</b> K60x20-Z	3 Nm (2.2 lbf ft)
-----------------------------	-----------------------------	-------------------

- Mount the seat. (📖 p. 17)

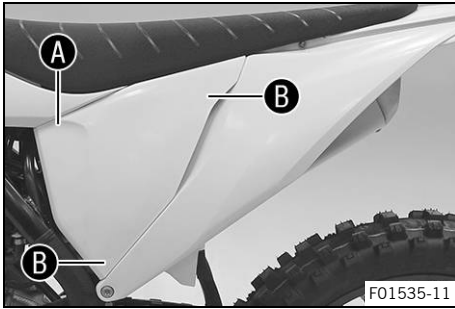

**Condition**

The air filter box cover is not secured.

- Insert the air filter box cover in area **A** and clip it into area **B**.

### 3.10 Installing the engine guard (Factory Edition)

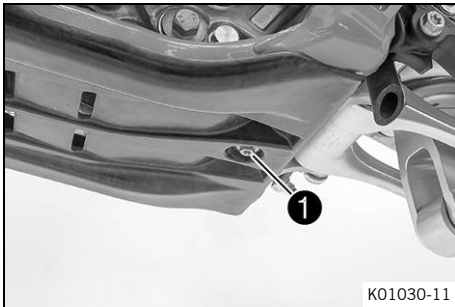

- Position the engine guard on the frame.
- Mount and tighten screw **1**.

Guideline

Remaining screws, chassis	M6	10 Nm (7.4 lbf ft)
---------------------------	----	--------------------

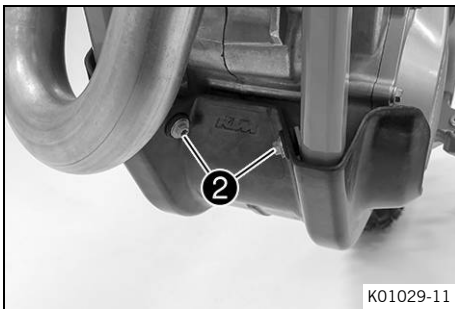

- Mount and tighten screws **2**.

Guideline

Remaining screws, chassis	M6	10 Nm (7.4 lbf ft)
---------------------------	----	--------------------

### 3.11 Charging the 12-V battery



**Warning**

**Risk of injury** 12 V batteries contain harmful substances.

- Keep 12 V batteries out of the reach of children.
- Keep sparks and open flames away from 12 V batteries.
- Only charge 12 V batteries in well-ventilated rooms.
- Maintain a minimum clearance from inflammable materials when charging 12 V batteries.  
Minimum clearance 1 m (3 ft)
- Do not charge deeply discharged 12 V batteries if the charge is already below the minimum voltage.  
Minimum voltage before the start of the charge 9 V
- Dispose of 12 V batteries with less than the minimum voltage correctly.



**Note**

**Environmental hazard** 12 V batteries contain environmentally hazardous materials.

- Do not dispose of 12 V batteries as household waste.
- Dispose of 12 V batteries at a collection point for used batteries.



**Note**

**Environmental hazard** Hazardous substances cause environmental damage.

- Dispose of oils, grease, filters, fuel, cleaning agents, brake fluid, etc., correctly and in compliance with the applicable regulations.



**Info**

Even when there is no load on the 12-V battery, it discharges steadily each day. The charging level and the method of charging are very important for the service life of the 12-V battery. Rapid recharging with a high charging current shortens the service life of the battery. If the charging current, charging voltage, or charging time is exceeded, the 12-V battery will be destroyed. If the 12-V battery is depleted by repeated starting, the 12-V battery must be charged immediately. If the 12-V battery is left in a discharged state for an extended period, it will become deeply discharged and suffer a loss of capacity, destroying the battery. The 12-V battery is maintenance-free.

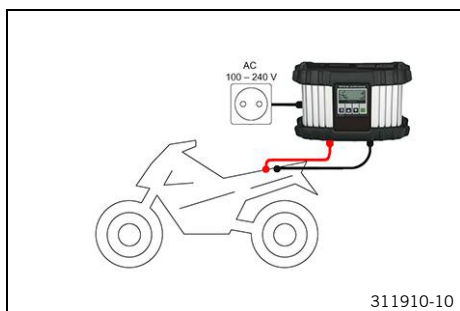

**Preparatory work**

- Remove the seat. (📖 p. 17)
- Disconnect the negative cable of the 12-V battery. (📖 p. 22)

**Main work**

- Connect a battery charger to the 12-V battery. Adjust the battery charger.

EU battery charger **XCharge-professional** (00029095050)

**Alternative 1**

US battery charger **XCharge-professional** (00029095051)

**Alternative 2**

UK battery charger **XCharge-professional** (00029095052)



**Info**

Follow the instructions of the charger and the manual.

- Disconnect the battery charger after charging the 12-V battery.
- Guideline

The charging current, charging voltage, and charging time must not be exceeded.	
Recharge the 12-V battery regularly when the motorcycle is not being used	3 months

**Finishing work**

- Connect the negative cable of the 12 V battery. (📖 p. 22)
- Mount the seat. (📖 p. 17)



## 3.12 Disconnecting the negative cable of the 12-V battery

### Preparatory work

- Remove the seat. (📖 p. 17)

### Main work

- Disconnect negative cable ❶ of the 12-V battery.

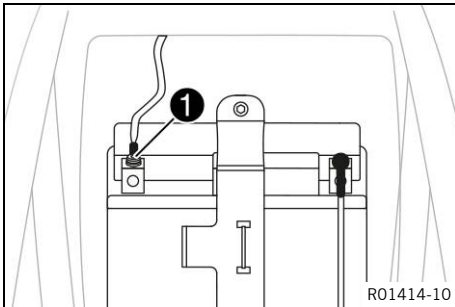

## 3.13 Connecting the negative cable of the 12 V battery

### Main work

- Connect negative cable ❶ of the 12 V battery.

### Guideline

Screw, battery terminal	M5	2.5 Nm (1.84 lbf ft)
-------------------------	----	-------------------------

Contact disks **A** must be mounted under the screw **❷** and the cable lug **❸** with the claws toward the battery terminal.

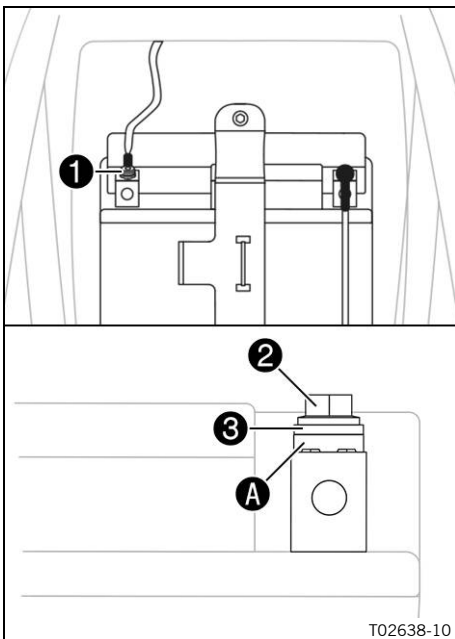

### Finishing work

- Mount the seat. (📖 p. 17)

## 3.14 Opening the fuel tank filler cap



### Danger

**Fire hazard** Fuel is highly flammable.

The fuel in the fuel tank expands when warm and can escape if overfilled.

- Do not fuel the vehicle in the vicinity of open flames or lit cigarettes.
- Switch off the engine for refueling.
- Make sure that no fuel is spilled; particularly not on hot parts of the vehicle.
- If any fuel is spilled, wipe it off immediately.
- Observe the specifications for refueling.





**Warning**

**Danger of poisoning** Fuel is poisonous and a health hazard.

- Avoid skin, eye and clothing contact with fuel.
- Immediately consult a doctor if you swallow fuel.
- Do not inhale fuel vapors.
- In case of skin contact, rinse the affected area with plenty of water.
- Rinse the eyes thoroughly with water, and consult a doctor in case of fuel contact with the eyes.
- Change your clothing in case of fuel spills on them.
- Keep fuels correctly in a suitable canister, and out of the reach of children.



**Note**

**Environmental hazard** Improper handling of fuel is a danger to the environment.

- Do not allow fuel to enter the groundwater, the soil, or the sewage system.

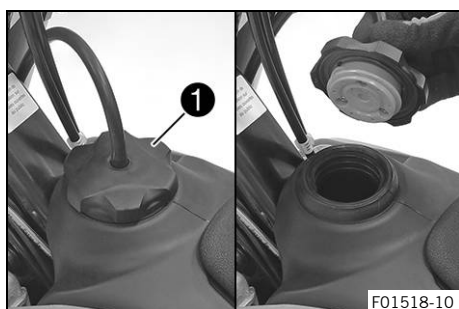

**(all SX-F models)**

- Turn fuel tank filler cap **1** counterclockwise and lift it off.

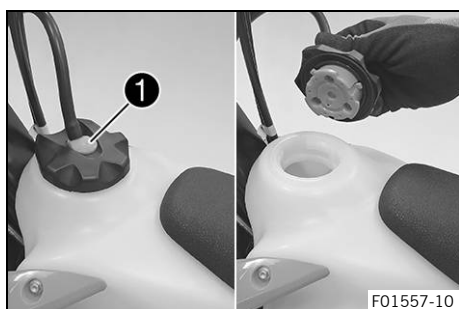

**(XC-F US)**

- Press release button **1**, turn the fuel tank filler cap counterclockwise, and lift it off.

**3.15 Closing the fuel tank filler cap**

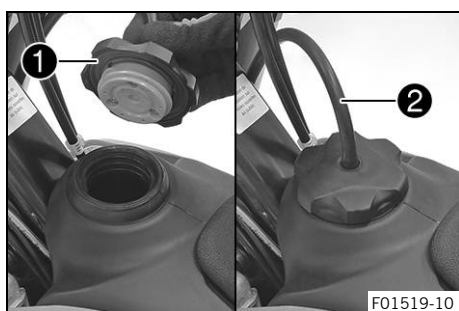

**(all SX-F models)**

- Mount fuel tank filler cap **1** and turn it clockwise until the fuel tank is tightly closed.



**Info**

Route fuel tank breather hose **2** without kinks.

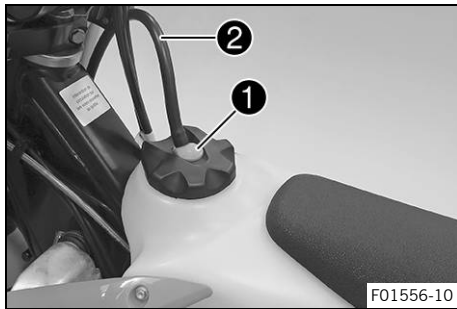

(XC-F US)

- Mount the fuel tank filler cap and turn it clockwise until release button ① engages.

**Info**

Route fuel tank breather hose ② without kinks.

### 3.16 Refueling

**Danger**

**Fire hazard** Fuel is highly flammable.

The fuel in the fuel tank expands when warm and can escape if overfilled.

- Do not fuel the vehicle in the vicinity of open flames or lit cigarettes.
- Switch off the engine for refueling.
- Make sure that no fuel is spilled; particularly not on hot parts of the vehicle.
- If any fuel is spilled, wipe it off immediately.
- Observe the specifications for refueling.

**Warning**

**Danger of poisoning** Fuel is poisonous and a health hazard.

- Avoid skin, eye and clothing contact with fuel.
- Immediately consult a doctor if you swallow fuel.
- Do not inhale fuel vapors.
- In case of skin contact, rinse the affected area with plenty of water.
- Rinse the eyes thoroughly with water, and consult a doctor in case of fuel contact with the eyes.
- Change your clothing in case of fuel spills on them.

**Note**

**Material damage** Inadequate fuel quality causes the fuel filter to quickly become clogged.

In some countries and regions, the available fuel quality and cleanliness may not be sufficient. This will result in problems with the fuel system.

- Refuel only with clean fuel that meets the specified standards.

**Note**

**Environmental hazard** Improper handling of fuel is a danger to the environment.

- Do not allow fuel to enter the groundwater, the soil, or the sewage system.

- Switch off the engine.
- Open the fuel tank filler cap. (📖 p. 22)

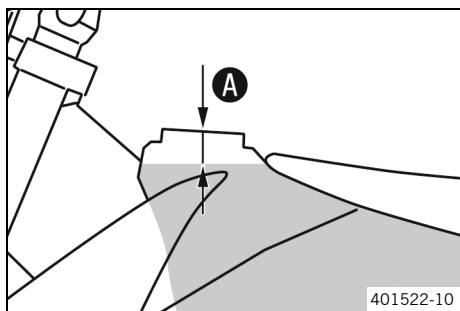

- Fill the fuel tank with fuel up to measurement **A**.

Guideline

Measurement of <b>A</b>	35 mm (1.38 in)
Total fuel tank capacity, approx. (all SX-F models)	
Super unleaded (ROZ 95) (📖 p. 28)	7 l (1.8 US gal)
Total fuel tank capacity, approx. (XC-F US)	
Super unleaded (ROZ 95) (📖 p. 28)	8.5 l (2.25 US gal)

- Close the fuel tank filler cap. (📖 p. 23)



## 4 TECHNICAL DATA

### 4.1 Chassis tightening torques

Remaining screws, chassis	<b>EJOT PT®</b> K60x25-Z	1 Nm (0.7 lbf ft)
Screw, combination switch (All EU models)	<b>EJOT PT®</b> K50x18	2 Nm (1.5 lbf ft)
Screw, intake air temperature sensor (All EU models)	<b>EJOT PT®</b> K50x18	0.7 Nm (0.52 lbf ft)
Screw, pressure regulator (All EU models)	<b>EJOT PT®</b> K60x25-Z	2.3 Nm (1.7 lbf ft)
Screw, fixed grip	M4	5 Nm (3.7 lbf ft) <b>Loctite®243™</b>
Spoke nipple, front wheel	M4.5	6 Nm (4.4 lbf ft)
Spoke nipple, rear wheel	M4.5	6 Nm (4.4 lbf ft)
Remaining nuts, chassis	M5	5 Nm (3.7 lbf ft)
Remaining screws, chassis	M5	5 Nm (3.7 lbf ft)
Screw, battery terminal	M5	2.5 Nm (1.84 lbf ft)
Screw, frame protector	M5	3 Nm (2.2 lbf ft)
Screw, ground wire in tail section	M5	5 Nm (3.7 lbf ft)
Screw, intake air temperature sensor (All US models)	M5	3 Nm (2.2 lbf ft)
Screw, shock absorber adjusting ring	M5	5 Nm (3.7 lbf ft)
Screws on main silencer	M5	7 Nm (5.2 lbf ft)
Nut, starter motor	M6	4 Nm (3 lbf ft)
Remaining nuts, chassis	M6	10 Nm (7.4 lbf ft)
Remaining screws, chassis	M6	10 Nm (7.4 lbf ft)
Screw, ball joint of push rod on foot brake cylinder	M6	10 Nm (7.4 lbf ft) <b>Loctite®243™</b>
Screw, chain sliding guard	M6	6 Nm (4.4 lbf ft) <b>Loctite®243™</b>
Screw, front brake disc	M6	14 Nm (10.3 lbf ft) <b>Loctite®243™</b>
Screw, rear brake disc	M6	14 Nm (10.3 lbf ft) <b>Loctite®243™</b>
Screw, throttle grip	M6	5 Nm (3.7 lbf ft)
Fuel connection on fuel pump	M8	15 Nm (11.1 lbf ft)
Nut, foot brake lever stop	M8	20 Nm (14.8 lbf ft)
Nut, rear sprocket screw	M8	35 Nm (25.8 lbf ft) <b>Loctite®2701™</b>
Nut, rim lock	M8	12 Nm (8.9 lbf ft)
Remaining nuts, chassis	M8	25 Nm (18.4 lbf ft)
Remaining screws, chassis	M8	25 Nm (18.4 lbf ft)
Screw, chain sliding piece	M8	15 Nm (11.1 lbf ft)
Screw, engine brace	M8x15	25 Nm (18.4 lbf ft) <b>Loctite®2701™</b>
Screw, engine brace	M8x20	25 Nm (18.4 lbf ft) <b>Loctite®243™</b>
Screw, fork stub	M8	15 Nm (11.1 lbf ft)

Screw, front brake caliper	M8	25 Nm (18.4 lbf ft) <b>Loctite®243™</b>
Screw, handlebar clamp	M8	20 Nm (14.8 lbf ft)
Screw, manifold	M8	15 Nm (11.1 lbf ft)
Screw, side stand attachment	M8	33 Nm (24.3 lbf ft) <b>Loctite®2701™</b>
Screw, subframe	M8x20	30 Nm (22.1 lbf ft) <b>Loctite®2701™</b>
Screw, subframe	M8x30	30 Nm (22.1 lbf ft) <b>Loctite®2701™</b>
Nut, pull switch (All US models)	M8x1	0.8 Nm (0.59 lbf ft)
Engine attachment bolt	M10	60 Nm (44.3 lbf ft)
Remaining nuts, chassis	M10	45 Nm (33.2 lbf ft)
Remaining screws, chassis	M10	45 Nm (33.2 lbf ft)
Screw, bottom shock absorber	M10	60 Nm (44.3 lbf ft) <b>Loctite®2701™</b>
Screw, handlebar holder	M10	40 Nm (29.5 lbf ft) <b>Loctite®243™</b>
Screw, top shock absorber	M10	60 Nm (44.3 lbf ft) <b>Loctite®2701™</b>
Nut, fuel pump fixation	M12	15 Nm (11.1 lbf ft)
Nut, angle lever to link fork	M14x1.5	60 Nm (44.3 lbf ft)
Nut, frame on linkage lever	M14x1.5	60 Nm (44.3 lbf ft)
Nut, linkage lever on angle lever	M14x1.5	60 Nm (44.3 lbf ft)
Nut, fork pivot	M16x1.5	100 Nm (73.8 lbf ft)
Nut, rear wheel spindle	M20x1.5	80 Nm (59 lbf ft)
Screw, front wheel spindle	M20x1.5	35 Nm (25.8 lbf ft)
Screw, top steering head	M20x1.5	12 Nm (8.9 lbf ft)
Screw-in fitting, cooling system	M24x1.5	15 Nm (11.1 lbf ft) <b>Loctite®243™</b>

## Super unleaded (ROZ 95)

### Standard/classification

- DIN EN 228 (ROZ 95)

### Guideline

- Only use super unleaded fuel that matches or is equivalent to the specified standard.
- Fuel with an ethanol content of up to 10% (E10 fuel) is safe to use.



### Info

Do **not** use fuel containing methanol (e.g., M15, M85, M100) or more than 10% ethanol (e.g., E15, E25, E85, E100).

---

## Long-life grease

Recommended supplier

MOTOREX®

– Bike Grease 2000

**READY TO  
RACE**



3214370en

02/2021



**KTM Sportmotorcycle GmbH**  
5230 Mattighofen/Austria  
**KTM.com**



Photo: Mitterbauer/KISKA/KTM