

**250 EXC-F
250 EXC-F SIX DAYS**

Art. no. 3214375en



KTM

Perform the work described in these setup instructions before the vehicle is delivered to the customer.

Read the setup instructions in their entirety before beginning work.

These setup instructions were written to correspond to the latest state of this series. We reserve the right to make changes in the interest of technical advancement without at the same time updating this manual. We shall not provide a description of general workshop methods. Likewise, safety rules that apply in a workshop are not specified here. It is assumed that the work will be performed by a fully trained mechanic.

All specifications contained herein are non-binding. KTM Sportmotorcycle GmbH specifically reserves the right to modify or delete technical specifications, prices, colors, forms, materials, services, designs, equipment, etc., without prior notice and without specifying reasons, to adapt these to local conditions, as well as to stop production of a particular model without prior notice. KTM accepts no liability for delivery options, deviations from figures and descriptions, misprints, and other errors. The models portrayed partly contain special equipment that does not belong to the regular scope of supply.

© 2021 KTM Sportmotorcycle GmbH, Mattighofen Austria

All rights reserved

Reproduction, even in part, as well as copying of all kinds, is permitted only with the express written permission of the copyright owner.



ISO 9001(12 100 6061)

KTM applies quality assurance processes that lead to the highest possible product quality as defined in the ISO 9001 international quality management standard.

Issued by: TÜV Management Service

REG.NO. 12 100 6061

KTM Sportmotorcycle GmbH
Stallhofnerstraße 3
5230 Mattighofen, Austria

This document is valid for the following models:

250 EXC-F EU (F8103U9)

250 EXC-F BR (F8140U9)

250 EXC-F SIX DAYS EU (F8103U2)



1 MEANS OF REPRESENTATION

1.1 Symbols used

The meaning of specific symbols is described below.



Indicates an expected reaction (e.g. of a work step or a function).



Indicates an unexpected reaction (e.g. of a work step or a function).



Indicates a page reference (more information is provided on the specified page).



Indicates information with more details or tips.



Indicates the result of a testing step.



Indicates a voltage measurement.



Indicates a current measurement.



Indicates a resistance measurement.



Indicates the end of an activity including potential rework.

1.2 Formats used

The typographical formats used in this document are explained below.

Proprietary name

Indicates a proprietary name.

Name®

Indicates a protected name.

Brand™

Indicates a brand available on the open market.

Underlined terms

Refer to technical details of the vehicle or indicate technical terms, which are explained in the glossary.

2.1 Transport mode

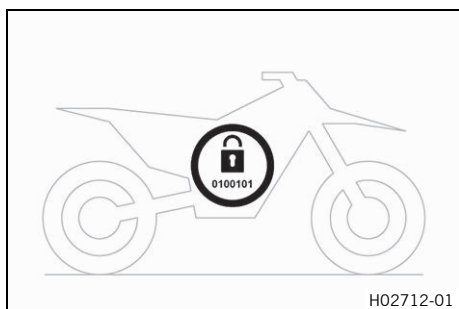

This vehicle was blocked for transport in the software. To operate the vehicle, the vehicle electronics must be enabled. This process is conducted during initial setup in KTM Dealer.net. Enabling ensures that the initial setup in KTM Dealer.net is documented.

Enabling can be performed either temporarily, e.g. for a test ride, or permanently for vehicle handover.



Info

Make sure that the vehicle is permanently enabled before handing it over to the customer.

2.2 Unpacking and setting up the vehicle

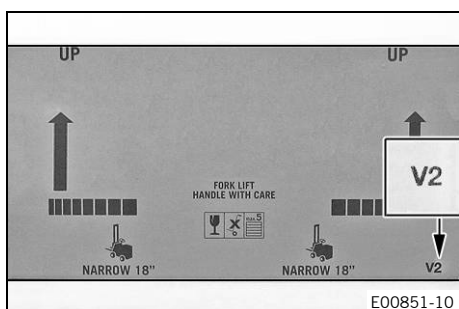

Condition

Packaging V2

- Remove the box and the plastic packaging.



Info

To avoid damaging the motorcycle during the setup, leave the protective film on the vehicle until you have finished.

- Remove the separate enclosure and unpack it. Check that the scope of supply is complete using the enclosed packing list.
- Have a lift stand available.

Lift stand (78129955100)

- Carefully loosen and remove the tension belt of the footrest mount.



Info

An assistant prevents the motorcycle from falling over.

- Together with an assistant, take the vehicle off the pallet.
- Position the vehicle on a lift stand.
- Check the vehicle for transport damage.

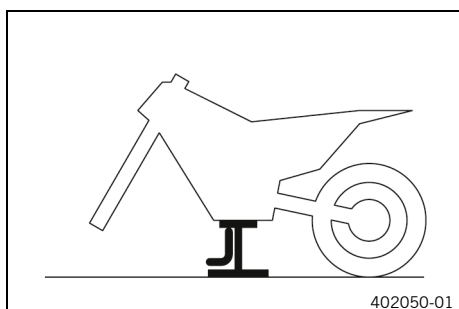

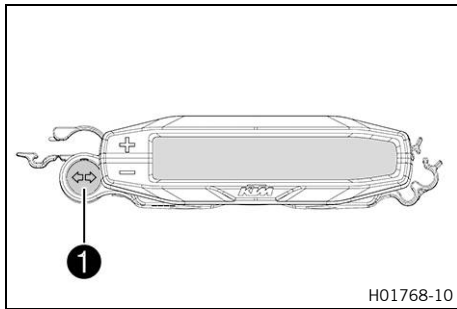

- Position the turn signal indicator lamp **1** in the combination instrument bracket.
- Remove the headlight mask with the headlight. (📖 p. 18)

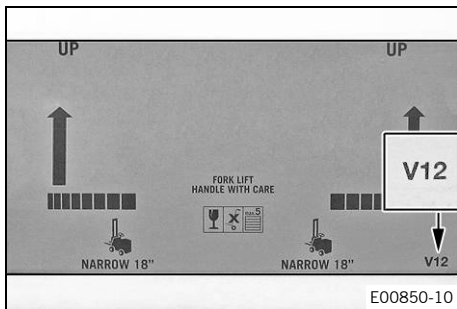

Condition

Packaging V12

- Remove the box and the plastic packaging.



Info

An assistant prevents the motorcycle from falling over. To avoid damaging the motorcycle during the setup, leave the protective film on the vehicle until you have finished.

- Remove and unpack the separate enclosure and attachments. Check that the scope of supply is complete using the enclosed packing list.
- Remove the two cable ties on the triple clamp.
- Have a lift stand available.

Lift stand (78129955100)

- Together with an assistant, take the vehicle off the pallet.
- Position the vehicle on a lift stand.
- Check the vehicle and attachments for transport damage.
- Install the shock absorber. (📖 p. 20)

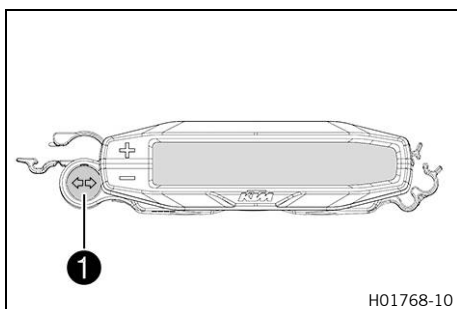
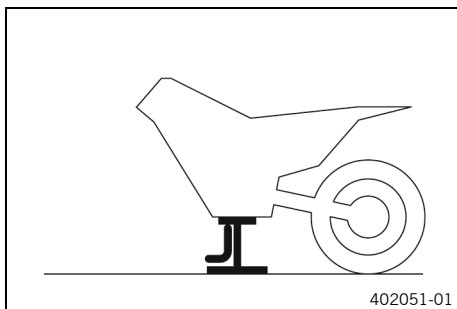

- Position turn signal indicator lamp **1** in the combination instrument bracket.

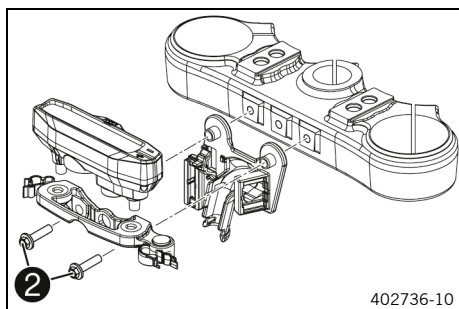

402736-10

- Position the connector board and combination instrument on the upper triple clamp.
- Mount and tighten screws **2**.

Guideline

Remaining screws, chassis	M6	10 Nm (7.4 lbf ft)
---------------------------	----	--------------------

- Route the clutch line with the clutch master cylinder toward the front between the upper and lower triple clamps.
- Install the fork legs. (📖 p. 21)

(EXC-F EU/BR)

- Remove screws **3** and take off the handlebar supports.
- Move the handlebar supports to the desired position and mount and tighten screws **3**.

Guideline

Screw, handlebar holder	M10	40 Nm (29.5 lbf ft) Loctite®243™
-------------------------	-----	--



Info

Position the left and right handlebar supports evenly.

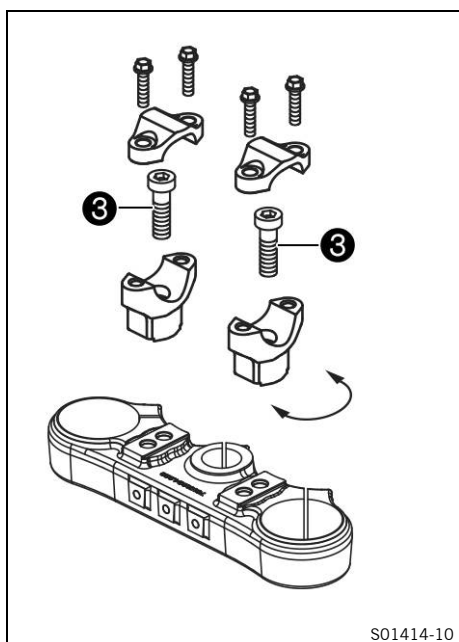

S01414-10



E00483-01



Warning

Danger of accidents A repaired handlebar poses a safety risk.

If the handlebar is bent or straightened, the material becomes fatigued. The handlebar may break as a result.

- Change the handlebar if the handlebar is damaged or bent.

- Position the handlebar.



Info

Make sure the cables and wiring are positioned correctly.

- Position the handlebar clamps. Mount and tighten the screws evenly.

Guideline

Screw, handlebar clamp	M8	20 Nm (14.8 lbf ft)
------------------------	----	------------------------

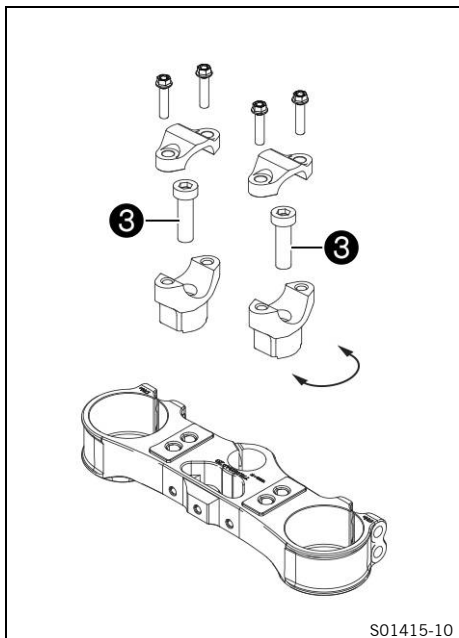

(EXC-F Six Days)

- Remove screws **3** and take off the handlebar supports.
- Move the handlebar supports to the desired position and mount and tighten screws **3**.

Guideline

Screw, handlebar holder	M10	40 Nm (29.5 lbf ft) Loctite®243™
-------------------------	-----	--

- i Info** Position the left and right handlebar supports evenly.



! Warning
Danger of accidents A repaired handlebar poses a safety risk.
 If the handlebar is bent or straightened, the material becomes fatigued. The handlebar may break as a result.

- Change the handlebar if the handlebar is damaged or bent.

- Position the handlebar.

- i Info** Make sure the cables and wiring are positioned correctly.

- Position the handlebar clamps. Mount and tighten the screws evenly.

Guideline

Screw, handlebar clamp	M8	20 Nm (14.8 lbf ft)
------------------------	----	------------------------



Info

The markings on the handlebar should be at the center of the handlebar clamps. Keep the installed gap widths equal when tightening.



S03665-01

- Position the controls on the right half of the handlebar.



S01423-01

- Position the controls on the left handlebar half.



S01422-01

(EXC-F Six Days)



Warning

Voiding of the government approval for road use and the insurance coverage If the combination switch is mounted, the vehicle's road permit, if any, expires.

- Only operate the vehicle in closed-off areas remote from public road traffic if the combination switch is installed.

- (Optional) Mount combination switch on the left side.



Info

The figure shows a possible installation position of the left side combination switch.

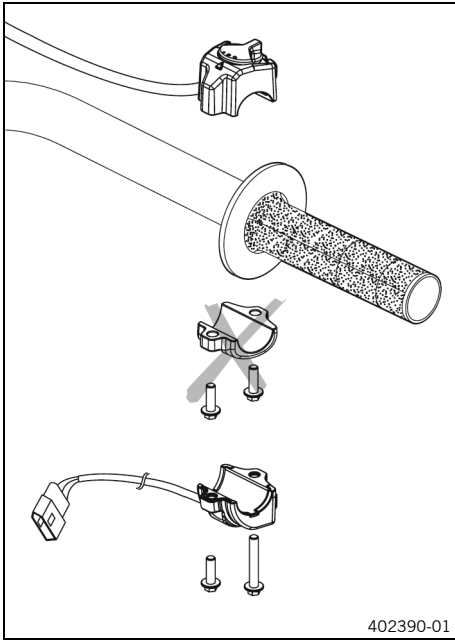

- Mount the turn signal switch.



Condition

Packaging V12

- Join all plug-in connectors to the connector board.
- Route the cables without tension and secure with the cable ties.

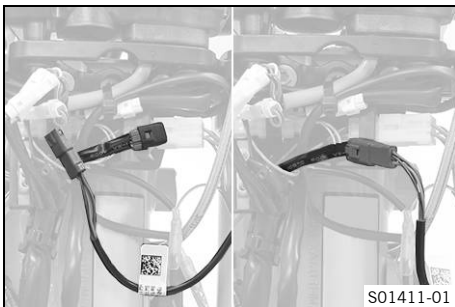

(EXC-F Six Days)



Warning

Voiding of the government approval for road use and the insurance coverage If the combination switch is mounted, the vehicle's road permit, if any, expires.

- Only operate the vehicle in closed-off areas remote from public road traffic if the combination switch is installed.

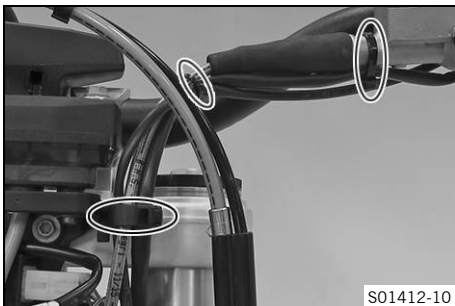

- (Optional) Remove the protection cap and join the plug-in connector of the left combination switch.
- Route the cable without tension and secure with cable ties and cable holders.

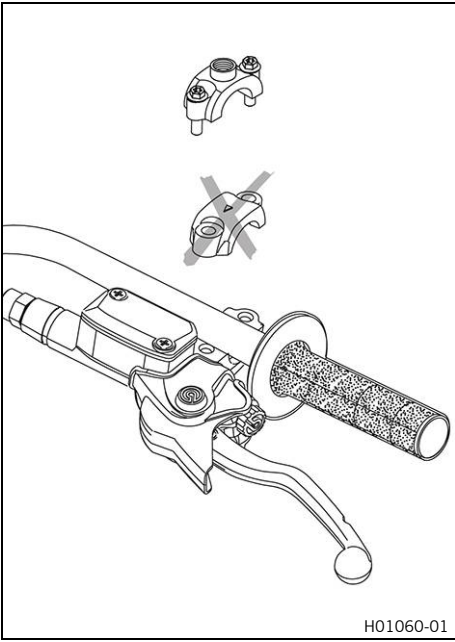

- Mount the mirror clamps on both sides.

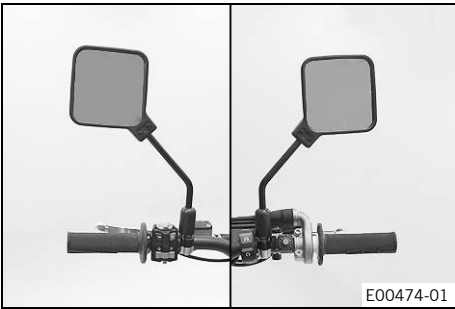

- Mount both rear mirrors with the adapter.



- Preassemble the hand guards on the left and right.

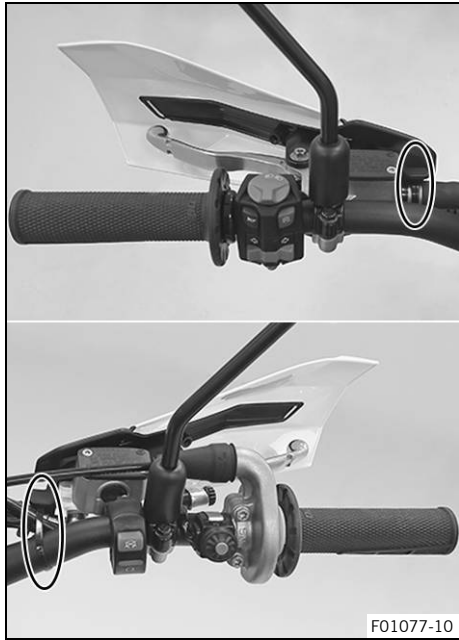

- Mount the left hand guard.
- Mount the right hand guard.

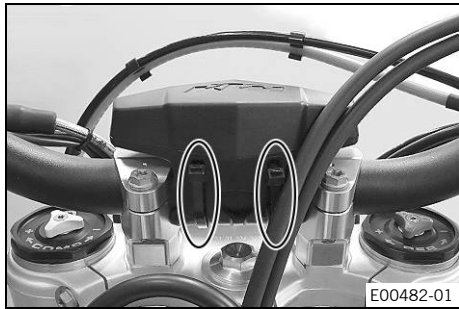

- Secure the handlebar cushion with two cable ties.
- Install front fender. (📖 p. 22)
- Install the front wheel. (📖 p. 22)

(All EU models)

- Remove the 12-V battery. (📖 p. 24)
- Charge the 12-V battery. (📖 p. 29)

(EXC-F BR)



Warning

Risk of injury Battery acid and battery gases cause serious chemical burns.

- Keep 12 V batteries out of the reach of children.
- Wear suitable protective clothing and safety glasses.
- Avoid contact with battery acid and battery gases.
- Keep sparks or open flames away from the 12 V battery.
- Only charge 12 V batteries in well-ventilated rooms.
- Rinse the affected area immediately with plenty of water in the event of contact with the skin.
- Rinse eyes with water for at least 15 minutes and consult a doctor immediately if battery acid and battery gases get into the eyes.

- Fill the 12 V battery.

i Info
Read the notes in the 12 V battery accessory pack.

- Charge the 12-V battery. (📖 p. 30)

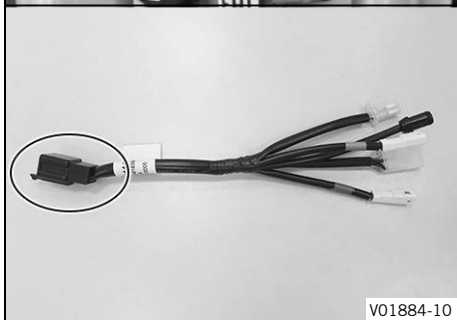
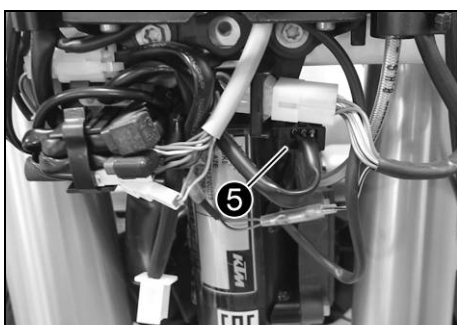

V01884-10

- Remove connector **5** from the bracket and join with turn signal wiring harness.

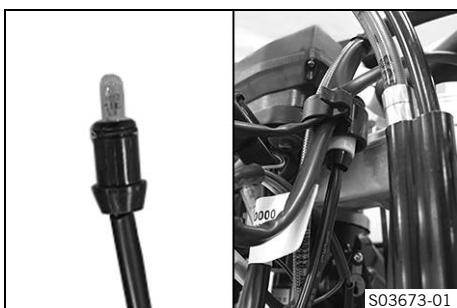

S03673-01

- Insert the black and violet cables of bulb included in the separate enclosure into the socket and position it in the turn signal indicator lamp.

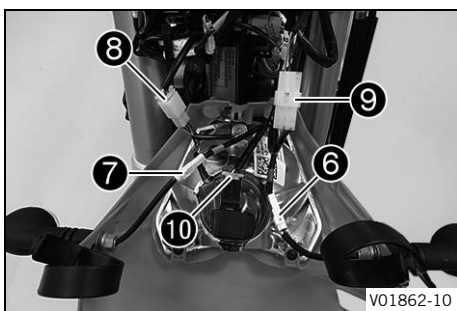

V01862-10

- Position the turn signal on the headlight mask on both sides, mount nuts with washers and tighten.
- Join plug-in connector **6** of the left turn signal using the violet and brown cable colors of the turn signal cable harness.

i Info
Pay attention to where the brake line is routed when doing so.

- Join plug-in connector **7** of the right turn signal using the black and brown cable colors of the turn signal cable harness.
- Join plug-in connector **8** of the headlight.
- Connect plug-in connector **9** of the turn signal switch.
- Secure turn signal relay **10** with a cable tie and plug in the connector.
- Install the headlight mask with the headlight. (📖 p. 19)
- Remove the air filter box cover. (📖 p. 31)
- Remove the rear left side cover. (📖 p. 32)

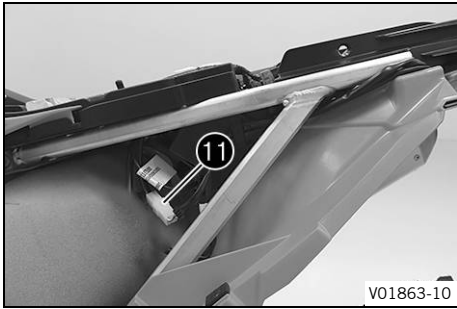

- Disconnect tail light plug-in connector **11** on the wiring harness.



- Remove screws **12**.
- Remove screws **13**.
- Remove the license plate holder with the tail light.

**Info**

Pay attention to the cable of the tail light.

- Feed the cable between the fairing parts.

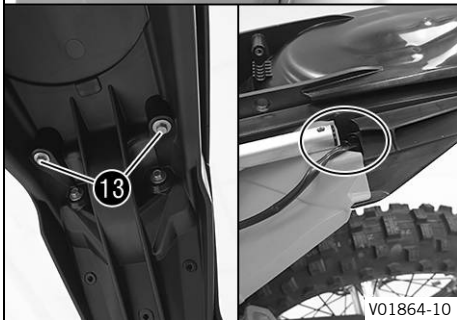

- Remove screws **14** on the license plate holder and hang the tail light to the side.





- Position the turn signal on both sides on the license plate holder, mount nuts with washers and tighten.
- Position the license plate lamp on the license plate holder, and mount and tighten screws 15.
- Mount reflector 16 on license plate holder.

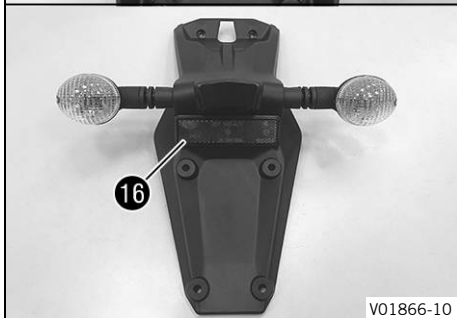

V01866-10

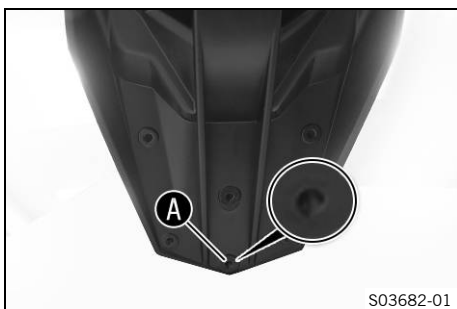

S03682-01

- Drill a hole at marking A on the license plate holder to the size of the marking.



- Position the tail light together with the license plate holder on the license plate bracket.



Info

Ensure that the cables are routed correctly.



S03683-10



- Mount and tighten screws **14**.

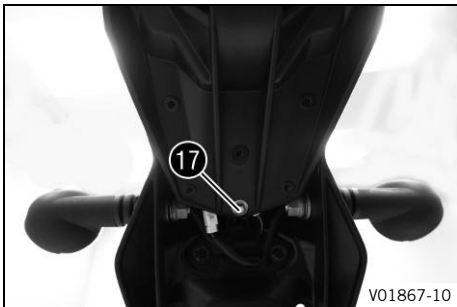

- Mount and tighten screw **17**.

Guideline

Remaining screws, chassis	EJOT PT® K60x25-Z	2 Nm (1.5 lbf ft)
---------------------------	-----------------------------	-------------------

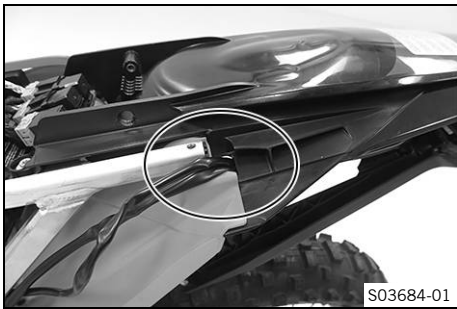

- Feed the wiring harnesses through the opening.
- Position the license plate holder on the rear.

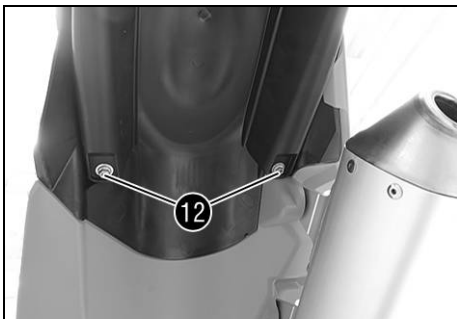

- Mount and tighten screws **12** with the collar bushing.

Guideline

Remaining screws, chassis	M6	10 Nm (7.4 lbf ft)
---------------------------	----	--------------------

- Mount and tighten screws **13**.

Guideline

Remaining screws, chassis	EJOT PT® K60x25-Z	2 Nm (1.5 lbf ft)
---------------------------	-----------------------------	-------------------



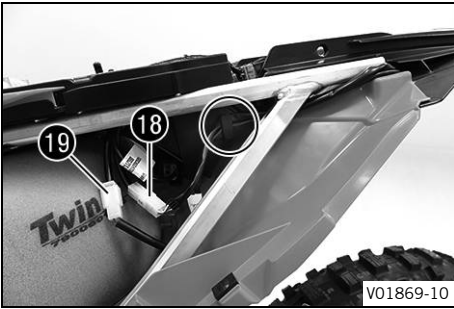

- Join the plug-in connectors of tail light **18** and turn signal cable harness **19** with the wiring harness.



Info

Pay attention to routing of the wiring harnesses.

- Install the rear left side cover. (📖 p. 33)
- Install the air filter box cover. (📖 p. 32)
- Install the 12-V battery. (📖 p. 26)

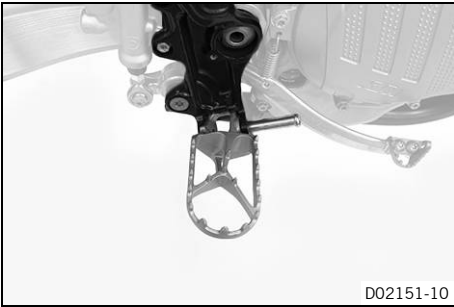

- Position the right footrest and pin.



Info

Only insert the pin to the extent that the spring can still be mounted.

- Position spring as shown.
 - ✓ Spring **B** engages in area **C**.

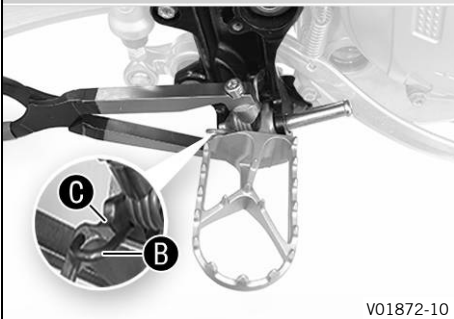
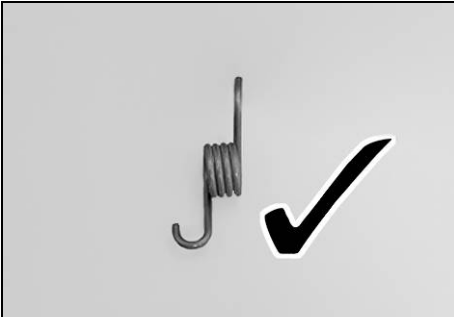

- Press the spring with special tool **20**.

Footrest spring plier (79029083000)

- ✓ The special tool is applied to area **D** on the footrest.
- Mount pin **21**.

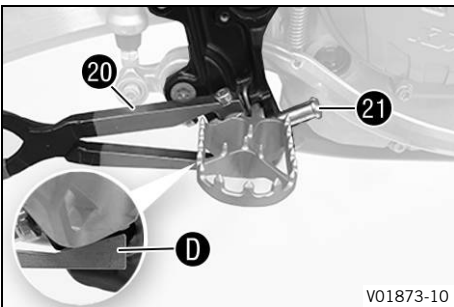

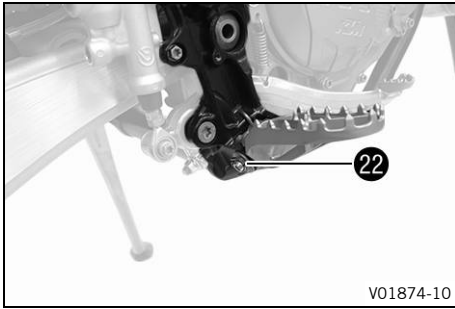

- Mount the washer and splint **22**.

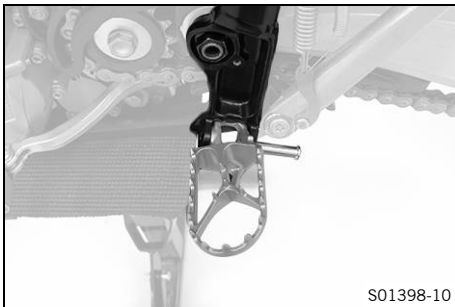

- Position the left footrest and pin.



Info

Only insert the pin to the extent that the spring can still be mounted.

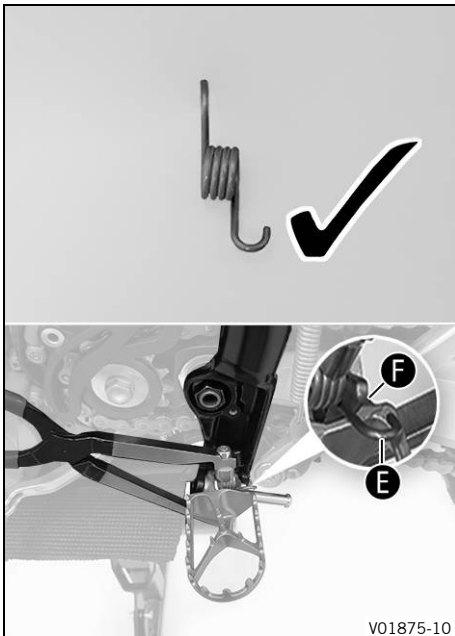

- Position spring as shown.
- ✓ Spring **E** engages in area **F**.

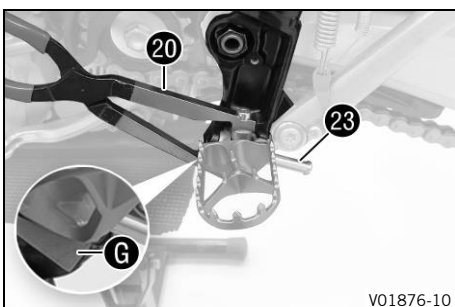

- Press the spring with special tool **20**.

Footrest spring plier (79029083000)

- ✓ The special tool is applied to area **G** on the footrest.
- Mount pin **23**.

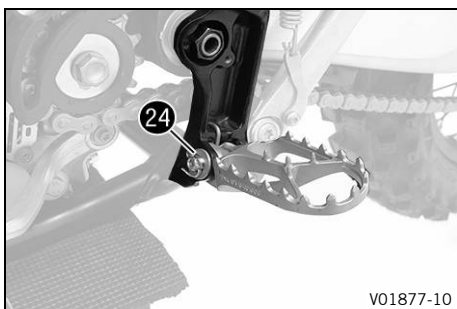

- Mount the washer and splint 24.

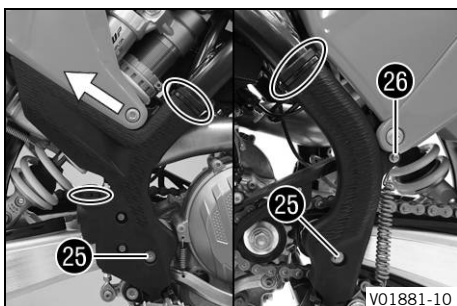

- Position the frame protectors on both sides.
- Mount and tighten screws 25.

Guideline

Screw, frame protector	M5	3 Nm (2.2 lbf ft)
------------------------	----	-------------------

- Mount and tighten screw 26 with washers.

Guideline

Screw, frame protector	M5	3 Nm (2.2 lbf ft)
------------------------	----	-------------------

- Mount the cable ties.

(EXC-F Six Days)

- Install the engine guard. (📖 p. 33)
- Unpack and mount the **KTM PowerParts** included in the delivery (optional).



Info

Read the accompanying **KTM PowerParts** fitting instructions.

- Attach the stickers included in the scope of supply (optional).
- Set the kilometers or miles. (📖 p. 35)
- Set the combination instrument. (📖 p. 36)
- Set the clock. (📖 p. 37)
- Refuel. (📖 p. 34)
- Position all controls in their exact positions on the handlebar. Tighten all screws.
- Prepare the vehicle according to the specifications in **KTM Dealer.net** for handover to the customer.



Info

Transport mode must be deactivated to be able to start the motorcycle.

3.1 Raising the motorcycle with the lift stand

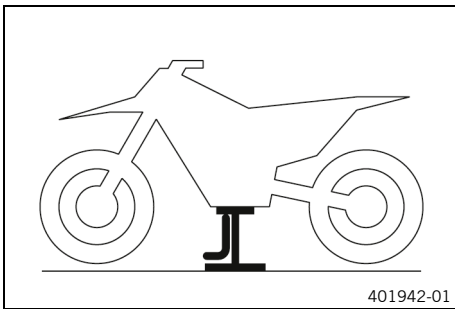

Note

Danger of damage The parked vehicle can roll away or fall over.

- Park the vehicle on a firm and level surface.
- Raise the motorcycle at the frame underneath the engine.

Lift stand (78129955100)

- ✓ Neither wheel is in contact with the ground.
- Secure the motorcycle against falling over.

3.2 Removing the motorcycle from the lift stand

Note

Danger of damage The parked vehicle can roll away or fall over.

- Park the vehicle on a firm and level surface.

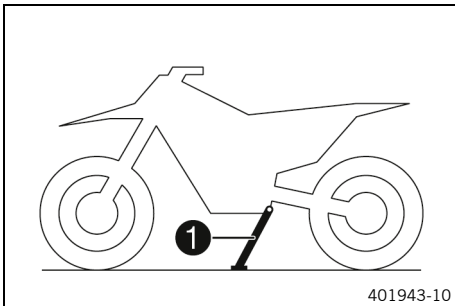

- Remove the motorcycle from the lift stand.
- Remove the lift stand.
- To park the motorcycle, press side stand ① to the ground with your foot and lean the motorcycle on it.

Info

When you are riding, the side stand must be folded up and secured with rubber strap.

3.3 Removing the headlight mask with the headlight

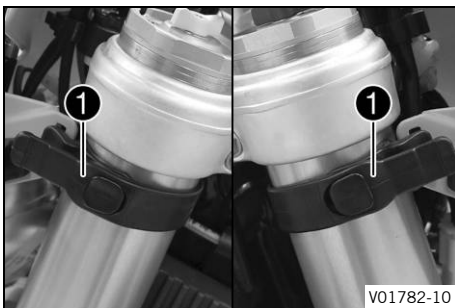

- Detach the brake line and wiring harness from the headlight mask.
- Loosen rubber straps ①. Slide the headlight mask up and swing it forward.

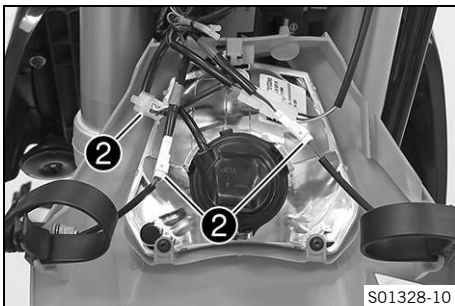

- Detach plug-in connectors ② and take off the headlight mask with the headlight.

3.4 Installing the headlight mask with the headlight

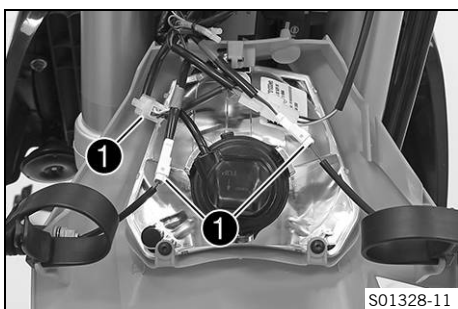

Main work

- Join plug-in connectors ①.

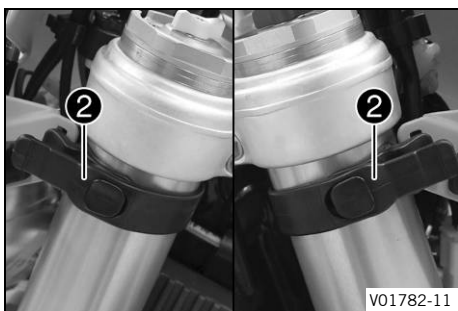

- Position the headlight mask and secure it with rubber straps ②.
- ✓ The holding lugs engage in the fender.
- Position the brake line and wiring harness in the brake line guide.

Finishing work

- Check the headlight setting. (📖 p. 19)

3.5 Checking the headlight setting

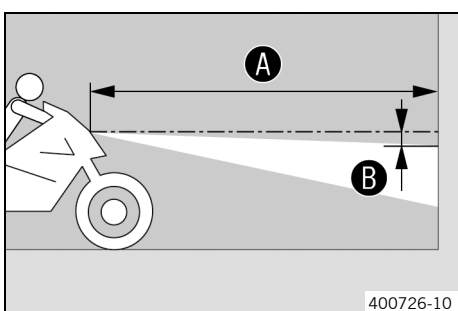

- Position the vehicle upright on a horizontal surface in front of a light wall and make a marking at the height of the center of the low beam headlight.

- Make another mark at a distance ⑤ under the first marking.

Guideline

Distance ⑤	5 cm (2 in)
------------	-------------

- Position the vehicle vertically at a distance ④ away from the wall.

Guideline

Distance ④	5 m (16 ft)
------------	-------------

- The rider now sits down on the motorcycle.
- Switch on the low beam.
- Check the headlight setting.

The boundary between light and dark must be exactly on the lower mark for a motorcycle with rider.

- » If the boundary between light and dark does not meet specifications:

- Adjust the headlight range. (📖 p. 20)

3.6 Adjusting the headlight range

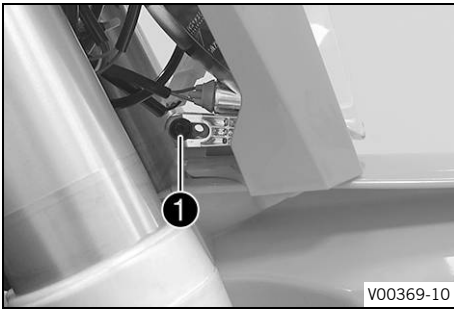

Preparatory work

- Check the headlight setting. (📖 p. 19)

Main work

- Loosen screw ❶.
- Adjust the headlight range by pivoting the headlight.

Guideline

The boundary between light and dark must be exactly on the lower mark for a motorcycle with rider (instructions on how to apply the mark: Checking the headlight setting).

i Info

A change in weight on the vehicle may require a correction of the headlight range.

- Tighten screw ❶.

3.7 Installing the shock absorber

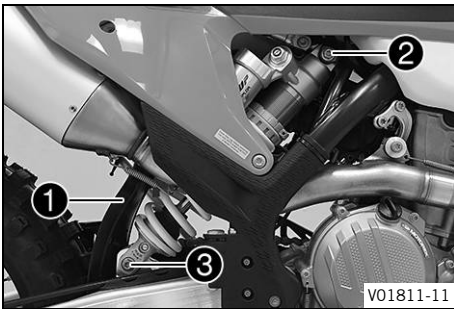

Main work

- Push splash protector ❶ to the side and position the shock absorber. Mount and tighten screw ❷.

Guideline

Screw, top shock absorber	M12	80 Nm (59 lbf ft) Loctite®2701™
---------------------------	-----	---

- Mount and tighten screw ❸.

Guideline

Screw, bottom shock absorber	M12	80 Nm (59 lbf ft) Loctite®2701™
------------------------------	-----	---

i Info

The heim joint for the shock absorber on the link fork is Teflon coated. It must not be lubricated with grease, nor with any other lubricants. Lubricants dissolve the Teflon coating, thereby drastically reducing the service life.

Finishing work

- Remove the motorcycle from the lift stand. (📖 p. 18)

3.8 Installing the fork legs

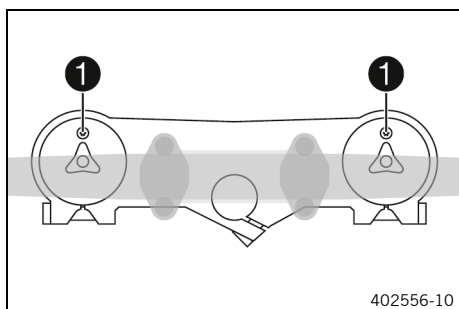

Main work

- Position the fork legs.
- ✓ Bleeder screws **1** are positioned toward the front.



Info

The rebound damping is located in right fork leg **REB** (red adjusting screw). The compression damping is located in left fork leg **COM** (white adjusting screw). Grooves are milled into the side of the upper end of the fork legs. The second milled groove (from the top) must be flush with the upper edge of the upper triple clamp.

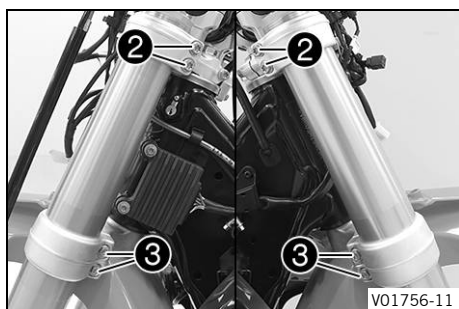

(EXC-F EU/BR)

- Tighten screws **2**.

Guideline

Screw, top triple clamp	M8	20 Nm (14.8 lbf ft)
-------------------------	----	------------------------

- Tighten screws **3**.

Guideline

Screw, bottom triple clamp	M8	15 Nm (11.1 lbf ft)
----------------------------	----	------------------------

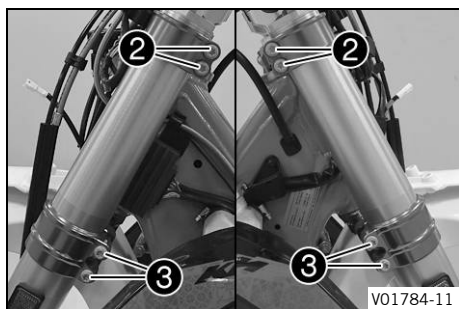

(EXC-F Six Days)

- Tighten screws **2**.

Guideline

Screw, top triple clamp	M8	17 Nm (12.5 lbf ft)
-------------------------	----	------------------------

- Tighten screws **3**.

Guideline

Screw, bottom triple clamp	M8	15 Nm (11.1 lbf ft)
----------------------------	----	------------------------

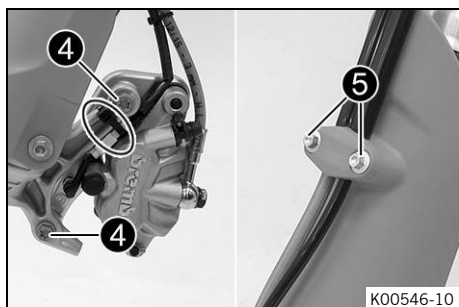

- Position the brake caliper, and mount and tighten screws **4**.

Guideline

Screw, front brake caliper	M8	25 Nm (18.4 lbf ft) Loctite®243™
----------------------------	----	--

- Mount the cable ties.
- Position the brake line, the wiring harness, and the clamp. Mount and tighten screws **5**.

Finishing work

- Install the front wheel. (📖 p. 22)
- Install the headlight mask with the headlight. (📖 p. 19)
- Check the headlight setting. (📖 p. 19)

3.9 Installing the front wheel



Warning

Danger of accidents Oil or grease on the brake discs reduces the braking effect.

- Always keep the brake discs free of oil and grease.
- Clean the brake discs with brake cleaner when necessary.

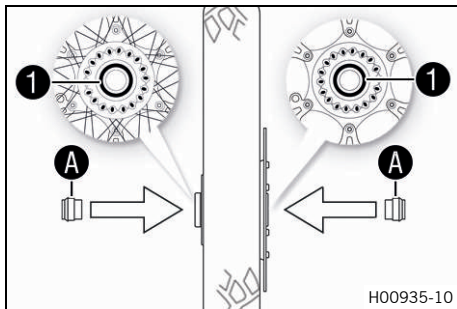

- Check the wheel bearing for damage and wear.
 - » If the wheel bearing is damaged or worn:
 - Change front wheel bearing.
- Clean and grease shaft seal rings ① and contact surfaces A of the spacers.

Long-life grease (📖 p. 41)

- Insert the spacers.
- Clean and grease the wheel spindle.

Long-life grease (📖 p. 41)

- Position the front wheel and insert the wheel spindle.
 - ✓ The brake linings are correctly positioned.

- Mount and tighten screw ②.

Guideline

Screw, front wheel spindle	M20x1.5	35 Nm (25.8 lbf ft)
----------------------------	---------	---------------------

- Operate the hand brake lever several times until the brake linings are seated correctly against the brake disc.
- Remove the motorcycle from the lift stand. (📖 p. 18)
- Operate the front brake and compress the fork a few times firmly.
 - ✓ The fork legs straighten.

- Tighten screws ③.

Guideline

Screw, fork stub	M8	15 Nm (11.1 lbf ft)
------------------	----	---------------------

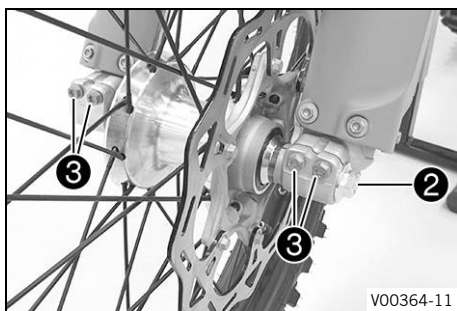

3.10 Installing front fender

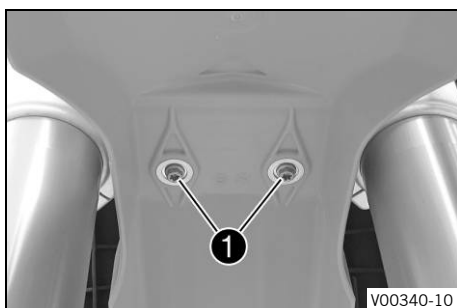

Main work (EXC-F EU/BR)

- Position front fender. Mount and tighten screws ①.

Guideline

Remaining screws, chassis	M6	10 Nm (7.4 lbf ft)
---------------------------	----	--------------------

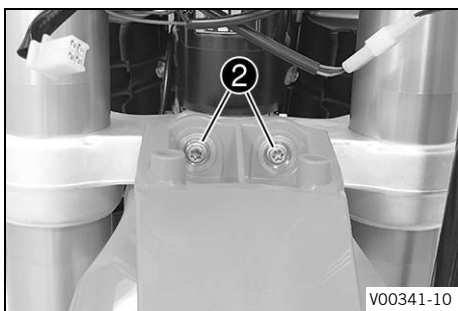

- Mount and tighten screws ②.

Guideline

Remaining screws, chassis	M6	10 Nm (7.4 lbf ft)
---------------------------	----	--------------------

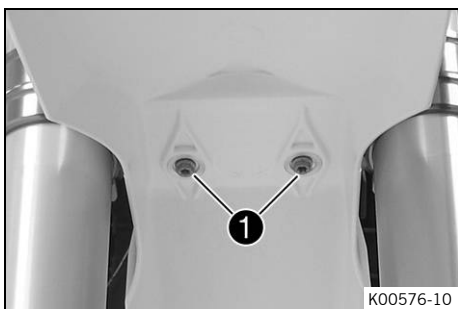

(EXC-F Six Days)

- Position front fender. Mount and tighten screws ①.

Guideline

Remaining screws, chassis	M6	10 Nm (7.4 lbf ft)
---------------------------	----	--------------------

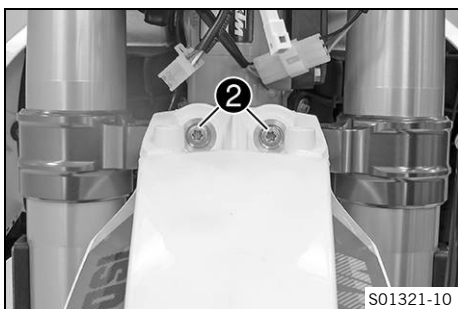

- Mount and tighten screws ②.

Guideline

Remaining screws, chassis	M6	10 Nm (7.4 lbf ft)
---------------------------	----	--------------------

Finishing work

- Install the headlight mask with the headlight. (📖 p. 19)
- Check the headlight setting. (📖 p. 19)

3.11 Removing the seat

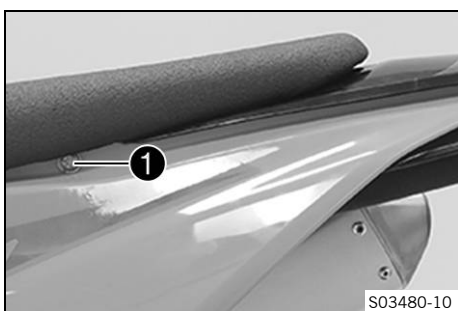

- Remove screw ①.

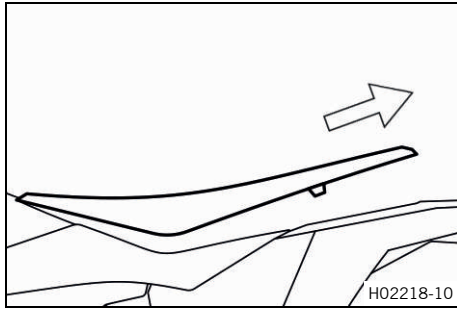

- Raise the rear of the seat, pull the seat back, and lift it off.

3.12 Mounting the seat

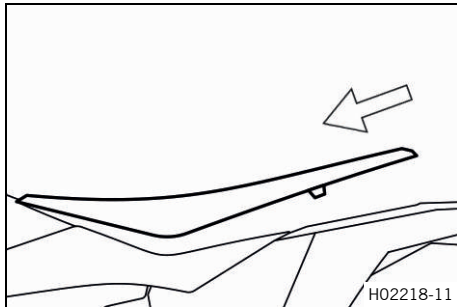

- Mount the front of the seat on the collar bushings of the fuel tank, lower the seat at the rear, and push the seat forward.
- Make sure the seat is correctly latched in place.

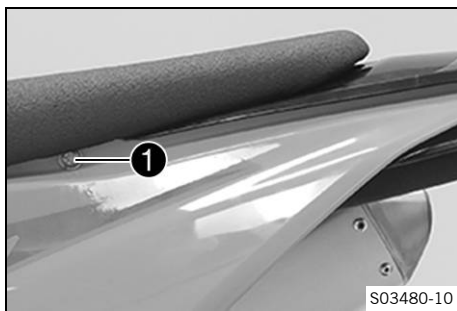

- Mount and tighten screw ①.

Guideline

Remaining screws, chassis	M6	10 Nm (7.4 lbf ft)
---------------------------	----	--------------------

3.13 Removing the 12-V battery



Note

Environmental hazard 12 V batteries contain environmentally hazardous materials.

- Do not dispose of 12 V batteries as household waste.
- Dispose of 12 V batteries at a collection point for used batteries.



Note

Environmental hazard Hazardous substances cause environmental damage.

- Dispose of oils, grease, filters, fuel, cleaning agents, brake fluid, etc., correctly and in compliance with the applicable regulations.

Preparatory work

- Remove the seat. (📖 p. 23)

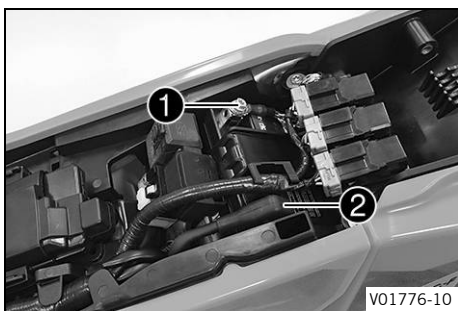

**Main work
(All EU models)**



Warning

Risk of injury 12 V batteries contain harmful substances.

- Keep 12 V batteries out of the reach of children.
- Keep sparks and open flames away from 12 V batteries.
- Only charge 12 V batteries in well-ventilated rooms.
- Maintain a minimum clearance from inflammable materials when charging 12 V batteries.

Minimum clearance 1 m (3 ft)

- Do not charge deeply discharged 12 V batteries if the charge is already below the minimum voltage.

Minimum voltage 9 V

before the start of the charge

- Dispose of 12 V batteries with less than the minimum voltage correctly.

- Disconnect negative cable ① from the 12-V battery.
- Pull back positive terminal cover ② and disconnect the positive cable from the 12-V battery.

(EXC-F BR)



Warning

Risk of injury Battery acid and battery gases cause serious chemical burns.

- Keep 12 V batteries out of the reach of children.
- Wear suitable protective clothing and safety glasses.
- Avoid contact with battery acid and battery gases.
- Keep sparks or open flames away from the 12 V battery.
- Only charge 12 V batteries in well-ventilated rooms.
- Rinse the affected area immediately with plenty of water in the event of contact with the skin.
- Rinse eyes with water for at least 15 minutes and consult a doctor immediately if battery acid and battery gases get into the eyes.

- Disconnect negative cable ① from the 12-V battery.

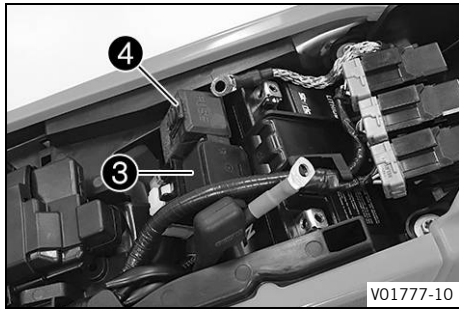

– Pull back positive terminal cover **2** and disconnect the positive cable from the 12-V battery.

– Pull off starter relay **3** and fuse box **4** from the battery compartment and hang to the side.

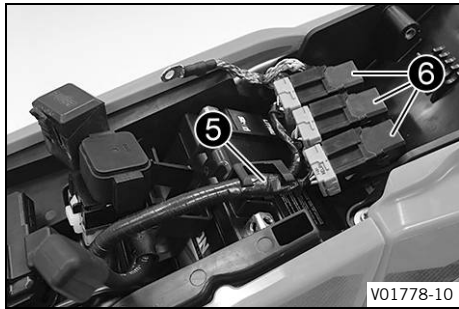

– Detach wiring harness **5**, disconnect relays **6** and hang them to the side.

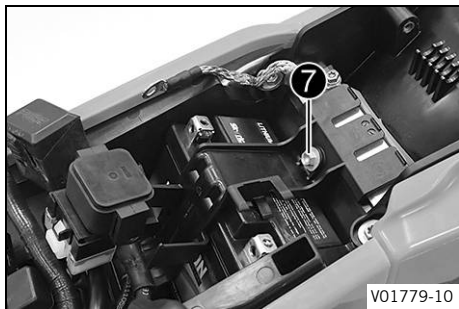

– Remove screw **7** and detach the battery compartment.

– Lift out the 12-V battery.

3.14 Installing the 12-V battery

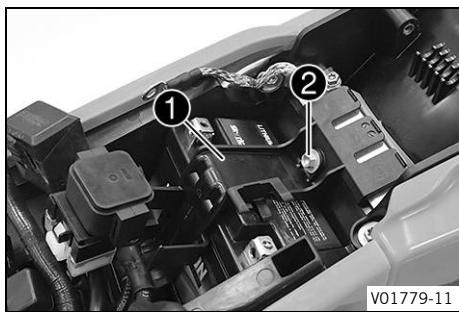

Main work

– Insert the 12-V battery into the battery compartment with the terminals facing forward and secure with holding bracket **1**.

(All EU models)

12 V battery (HJTZ5S-FP-C)

(EXC-F BR)

12 V battery (YTX5L-BS)

– Mount and tighten screw **2**.

Guideline

Remaining screws, chassis	M6	10 Nm (7.4 lbf ft)
---------------------------	----	--------------------

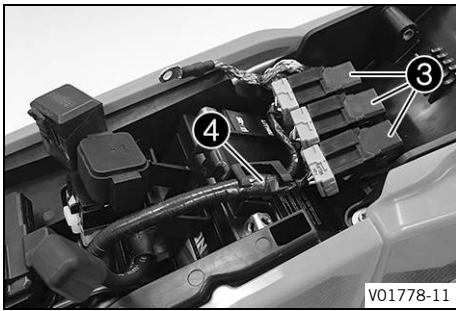

- Mount relays ③ and attach wiring harness ④.

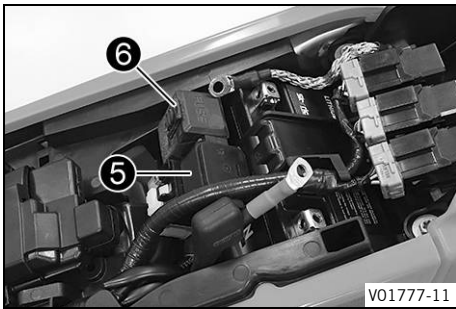

- Mount starter relay ⑤ and fuse box ⑥.

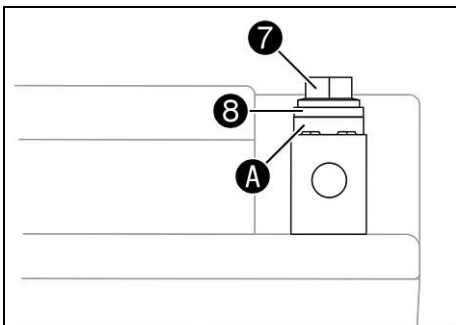

- Connect the positive cable to the 12-V battery.

Guideline

Screw, battery terminal	M5	2.5 Nm (1.84 lbf ft)
-------------------------	----	-------------------------

i Info
Contact disk **A** must be mounted under screw **7** and cable lug **8** with the claws toward the battery terminal.

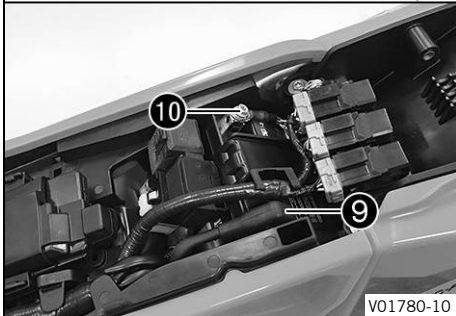

- Slide positive terminal cover ⑨ over the positive terminal.
- Connect negative cable ⑩ to the 12-V battery.

Guideline

Screw, battery terminal	M5	2.5 Nm (1.84 lbf ft)
-------------------------	----	-------------------------

i Info
Contact disk **A** must be mounted under screw **7** and cable lug **8** with the claws toward the battery terminal.

Finishing work

- Mount the seat. (🛠 p. 24)

3.15 Disconnecting the negative cable of the 12-V battery

Preparatory work

- Remove the seat. (📖 p. 23)

Main work

- Disconnect negative cable ❶ of the 12-V battery.

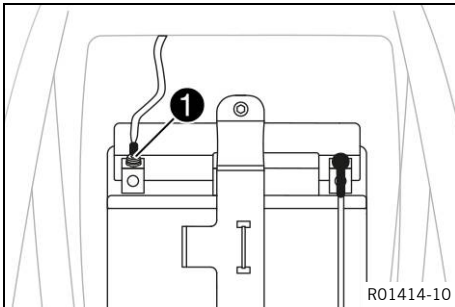

3.16 Connecting the negative cable of the 12-V battery

Main work

- Connect negative cable ❶ of the 12-V battery.

Guideline

Screw, battery terminal	M5	2.5 Nm (1.84 lbf ft)
-------------------------	----	-------------------------

Contact disk A must be mounted under screw ❷ and cable lug ❸ with the claws toward the battery terminal.

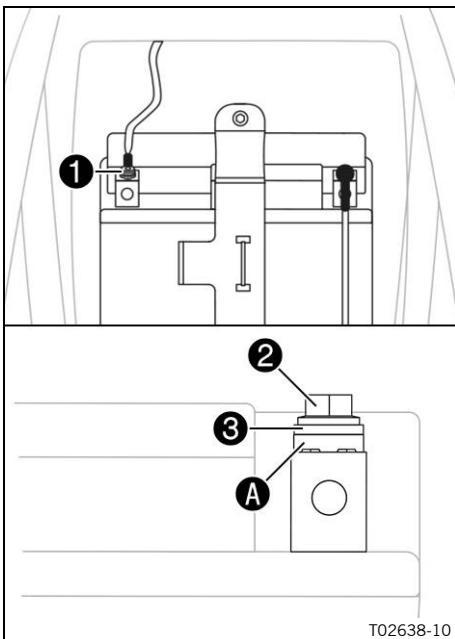

Finishing work

- Mount the seat. (📖 p. 24)

3.17 Charging the 12-V battery (All EU models)



Warning

Risk of injury 12 V batteries contain harmful substances.

- Keep 12 V batteries out of the reach of children.
- Keep sparks and open flames away from 12 V batteries.
- Only charge 12 V batteries in well-ventilated rooms.
- Maintain a minimum clearance from inflammable materials when charging 12 V batteries.
Minimum clearance 1 m (3 ft)
- Do not charge deeply discharged 12 V batteries if the charge is already below the minimum voltage.
Minimum voltage before the start of the charge 9 V
- Dispose of 12 V batteries with less than the minimum voltage correctly.



Note

Environmental hazard 12 V batteries contain environmentally hazardous materials.

- Do not dispose of 12 V batteries as household waste.
- Dispose of 12 V batteries at a collection point for used batteries.



Note

Environmental hazard Hazardous substances cause environmental damage.

- Dispose of oils, grease, filters, fuel, cleaning agents, brake fluid, etc., correctly and in compliance with the applicable regulations.



Info

Even when there is no load on the 12-V battery, it discharges steadily each day. The charging level and the method of charging are very important for the service life of the 12-V battery. Rapid recharging with a high charging current shortens the service life of the battery. If the charging current, charging voltage, and charging time are exceeded, the 12-V battery will be destroyed. If the 12-V battery is depleted from starting the vehicle repeatedly, the battery must be charged immediately. If the 12-V battery is left in a discharged state for an extended period, it will become deeply discharged and suffer a loss of capacity, destroying the battery. The 12-V battery is maintenance-free.

Preparatory work

- Remove the seat. (📖 p. 23)
- Disconnect the negative cable of the 12-V battery. (📖 p. 28)

Main work

- Connect a battery charger to the 12-V battery. Adjust the battery charger.

EU battery charger **XCharge-professional** (00029095050)

Alternative 1

US battery charger **XCharge-professional** (00029095051)

Alternative 2

UK battery charger **XCharge-professional** (00029095052)

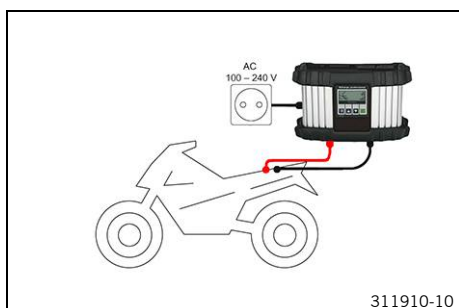

**Info**

Follow the instructions of the charger and the manual.

- Disconnect the battery charger after charging the 12-V battery.

Guideline

The charging current, charging voltage, and charging time must not be exceeded.

Recharge the 12-V battery regularly when the motorcycle is not being used	3 months
---	----------

Finishing work

- Connect the negative cable of the 12-V battery. (📖 p. 28)
- Mount the seat. (📖 p. 24)

3.18 Charging the 12-V battery (EXC-F BR)**Warning**

Risk of injury Battery acid and battery gases cause serious chemical burns.

- Keep 12 V batteries out of the reach of children.
- Wear suitable protective clothing and safety glasses.
- Avoid contact with battery acid and battery gases.
- Keep sparks or open flames away from the 12 V battery.
- Only charge 12 V batteries in well-ventilated rooms.
- Rinse the affected area immediately with plenty of water in the event of contact with the skin.
- Rinse eyes with water for at least 15 minutes and consult a doctor immediately if battery acid and battery gases get into the eyes.

**Note**

Environmental hazard 12 V batteries contain environmentally hazardous materials.

- Do not dispose of 12 V batteries as household waste.
- Dispose of 12 V batteries at a collection point for used batteries.

**Note**

Environmental hazard Hazardous substances cause environmental damage.

- Dispose of oils, grease, filters, fuel, cleaning agents, brake fluid, etc., correctly and in compliance with the applicable regulations.

**Info**

Even when there is no load on the 12-V battery, it discharges steadily each day.

The charging level and the method of charging are very important for the service life of the 12-V battery.

Rapid recharging with a high charging current shortens the service life of the battery.

If the charging current, charging voltage, or charging time is exceeded, the 12-V battery will be destroyed.

If the 12-V battery is depleted by repeated starting, the 12-V battery must be charged immediately.

If the 12-V battery is left in a discharged state for an extended period, it will become deeply discharged and sulfating occurs, destroying the battery.

The 12-V battery is maintenance-free, i.e. the acid level does not have to be checked.

Preparatory work

- Remove the seat. (📖 p. 23)
- Disconnect the negative cable of the 12-V battery. (📖 p. 28)

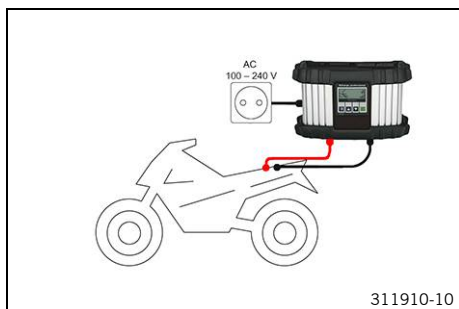

Main work

- Connect a battery charger to the 12-V battery. Adjust the battery charger.

EU battery charger **XCharge-professional** (00029095050)

Alternative 1

US battery charger **XCharge-professional** (00029095051)

Alternative 2

UK battery charger **XCharge-professional** (00029095052)

i Info

Follow the instructions of the charger and the manual.

- Disconnect the battery charger after charging the 12-V battery.
Guideline

The charging current, charging voltage, and charging time must not be exceeded.	
Recharge the 12-V battery regularly when the motorcycle is not being used	3 months

Finishing work

- Connect the negative cable of the 12-V battery. (📖 p. 28)
- Mount the seat. (📖 p. 24)



3.19 Removing the air filter box cover

Condition

The air filter box cover is secured.

- Remove the seat. (📖 p. 23)
- Remove screw **1**.

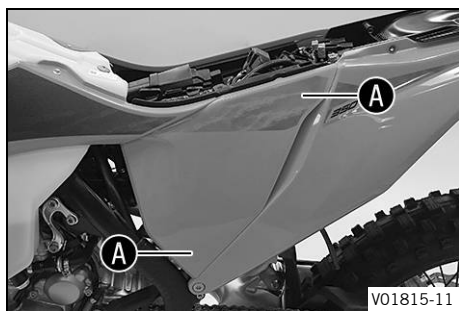
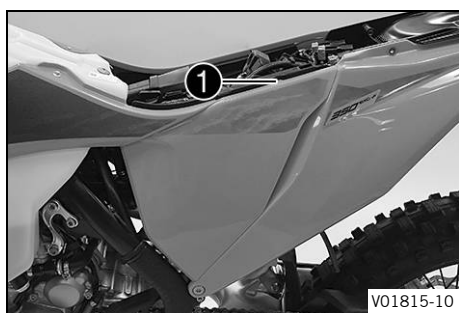

- Pull off the air filter box cover in area **A** laterally and take it off at the front.

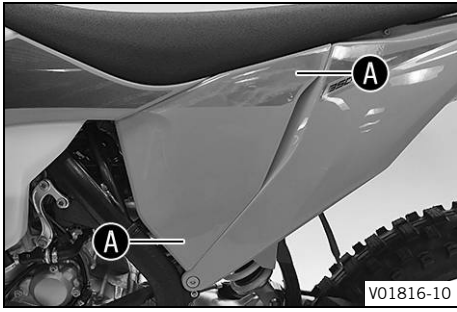

V01816-10

Condition

The air filter box cover is not secured.

- Pull off the air filter box cover in area **A** laterally and take it off at the front.

3.20 Installing the air filter box cover

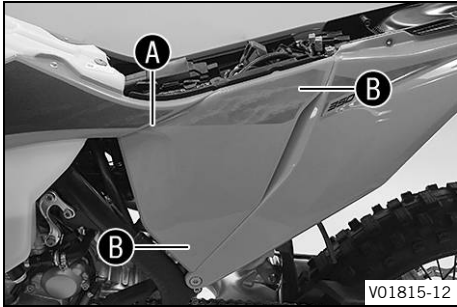

V01815-12

Condition

The air filter box cover is secured.

- Insert the air filter box cover in area **A** and clip it into area **B**.

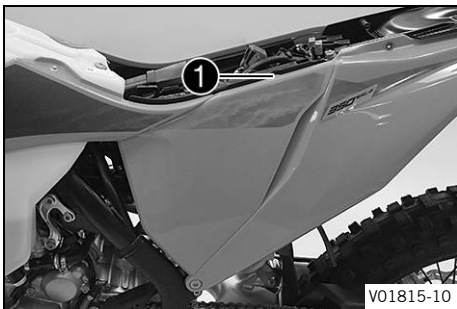

V01815-10

- Mount and tighten screw **1**.

Guideline

Screw, air filter box cover	EJOT PT® K60x20-Z	3 Nm (2.2 lbf ft)
-----------------------------	-----------------------------	-------------------

- Mount the seat. (📖 p. 24)

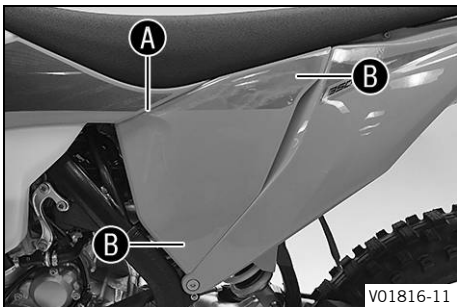

V01816-11

Condition

The air filter box cover is not secured.

- Insert the air filter box cover in area **A** and clip it into area **B**.

3.21 Removing the rear left side cover



V01871-10

- Remove screw **1** and take off fairing part to the front.

3.22 Installing the rear left side cover

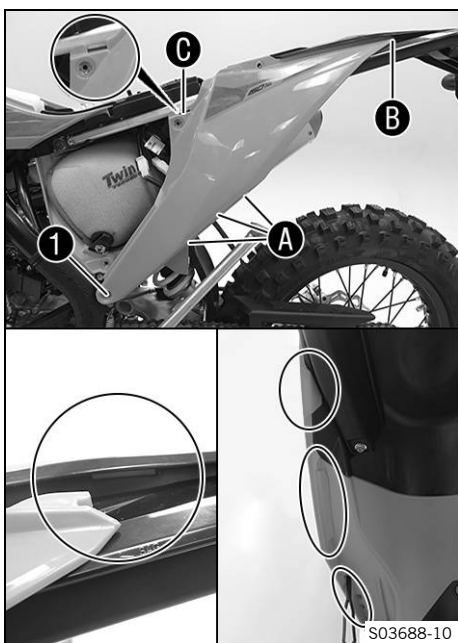

- Position side cover and hook it in in areas **A**, **B** and **C**.
- Mount and tighten screw **1**.

Guideline

Screw, sub-frame top	M8	35 Nm (25.8 lbf ft) Loctite®2701™
----------------------	----	---

3.23 Installing the engine guard (EXC-F Six Days)

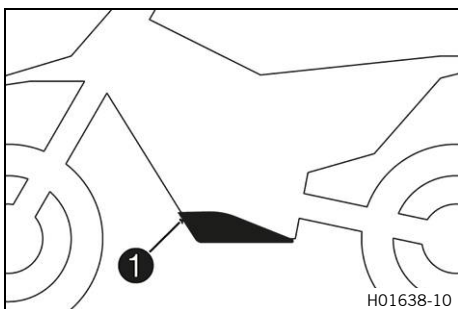

- Attach the engine guard on the frame at the rear and swing up at the front.
- Mount and tighten screws **1**.

Guideline

Remaining screws, chassis	M6	10 Nm (7.4 lbf ft)
---------------------------	----	--------------------

3.24 Opening fuel tank filler cap



Danger

Fire hazard Fuel is highly flammable.

The fuel in the fuel tank expands when warm and can escape if overfilled.

- Do not fuel the vehicle in the vicinity of open flames or lit cigarettes.
- Switch off the engine for refueling.
- Make sure that no fuel is spilled; particularly not on hot parts of the vehicle.
- If any fuel is spilled, wipe it off immediately.
- Observe the specifications for refueling.



Warning

Danger of poisoning Fuel is poisonous and a health hazard.

- Avoid skin, eye and clothing contact with fuel.
- Immediately consult a doctor if you swallow fuel.
- Do not inhale fuel vapors.
- In case of skin contact, rinse the affected area with plenty of water.
- Rinse the eyes thoroughly with water, and consult a doctor in case of fuel contact with the eyes.
- Change your clothing in case of fuel spills on them.
- Keep fuels correctly in a suitable canister, and out of the reach of children.



Note

Environmental hazard Improper handling of fuel is a danger to the environment.

- Do not allow fuel to enter the groundwater, the soil, or the sewage system.

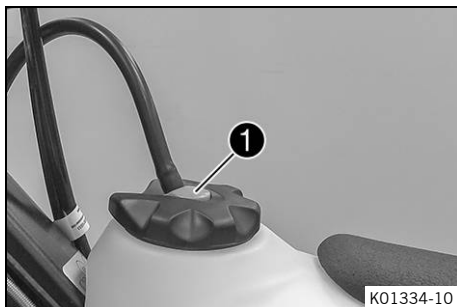

- Press release button **1**, turn the fuel tank filler cap counter-clockwise, and lift it off.

3.25 Closing the fuel tank filler cap

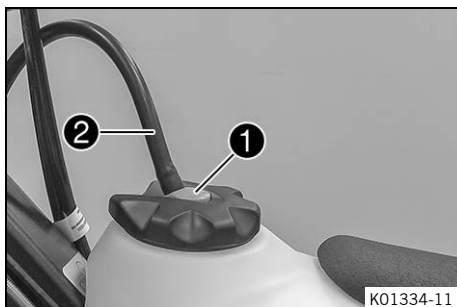

- Mount fuel tank filler cap and turn it clockwise until the release button **1** engages.



Info

Route fuel tank breather hose **2** without kinks.

3.26 Refueling



Danger

Fire hazard Fuel is highly flammable.

The fuel in the fuel tank expands when warm and can escape if overfilled.

- Do not fuel the vehicle in the vicinity of open flames or lit cigarettes.
- Switch off the engine for refueling.
- Make sure that no fuel is spilled; particularly not on hot parts of the vehicle.
- If any fuel is spilled, wipe it off immediately.
- Observe the specifications for refueling.



Warning

Danger of poisoning Fuel is poisonous and a health hazard.

- Avoid skin, eye and clothing contact with fuel.
- Immediately consult a doctor if you swallow fuel.
- Do not inhale fuel vapors.
- In case of skin contact, rinse the affected area with plenty of water.
- Rinse the eyes thoroughly with water, and consult a doctor in case of fuel contact with the eyes.
- Change your clothing in case of fuel spills on them.

Note

Material damage Inadequate fuel quality causes the fuel filter to quickly become clogged.

In some countries and regions, the available fuel quality and cleanliness may not be sufficient. This will result in problems with the fuel system.

- Refuel only with clean fuel that meets the specified standards.



Note

Environmental hazard Improper handling of fuel is a danger to the environment.

- Do not allow fuel to enter the groundwater, the soil, or the sewage system.

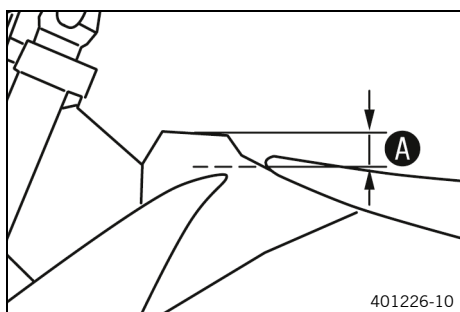

- Switch off the engine.
- Open fuel tank filler cap. (📖 p. 33)
- Fill the fuel tank with fuel up to level **A**.

Guideline

Level A	35 mm (1.38 in)	
Total fuel tank capacity, approx.	9.25 l (2.444 US gal)	Super unleaded (ROZ 95) (📖 p. 40) (All EU models)
Total fuel tank capacity, approx.		Super unleaded, type C (ROZ 95/RON 95/PON 91) (📖 p. 40) (EXC-F BR)

- Close the fuel tank filler cap. (📖 p. 34)



3.27 Setting the kilometers or miles



Info

If you change the unit, the value **ODO** is retained and converted accordingly. The values **TR1**, **TR2**, **A1**, **A2** and **S1** are cleared when the unit of measure is changed.

Condition

The motorcycle is stationary.

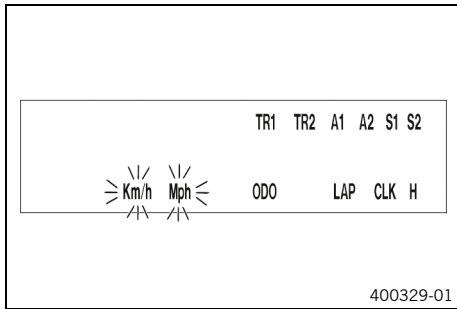

- Repeatedly press the button briefly until **H** appears at the bottom right of the display.
- Press the button for 2–3 seconds.
 - ✓ The Setup menu is displayed and the active functions are shown.
- Repeatedly press the button briefly until **Km/h/Mph** flashes.

Adjusting the Km/h

- Press the button .

Adjusting the Mph

- Press the button .
- Wait 3 - 5 seconds.
 - ✓ The settings are stored.



Info

If no button is pressed for 10–12 seconds, or if an impulse comes from the wheel speed sensor, the settings are automatically saved and the setup menu is closed.

3.28 Setting the combination instrument



Info

When the vehicle is delivered, only the **SPEED/H** and **SPEED/ODO** display modes are activated.

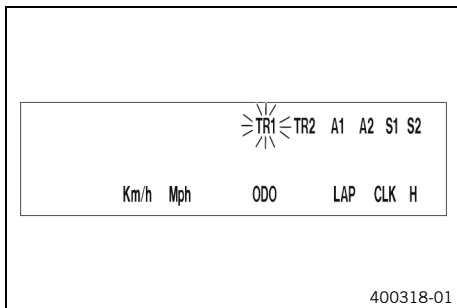

Condition

The motorcycle is stationary.

- Repeatedly press the button briefly until **H** appears at the bottom right of the display.
- Press the button for 2–3 seconds.
 - ✓ The Setup menu is displayed and the active functions are shown.



Info

If no button is pressed for 10–12 seconds, the settings are automatically saved.
If no button is pressed for 20 seconds, or if an impulse comes from the wheel speed sensor, the settings are automatically saved and the setup menu is closed.

- Repeatedly press the button briefly until the desired function flashes.
 - ✓ The selected function flashes.

Activating the function

- Press the button .
 - ✓ The symbol continues to appear in the display and the next function appears.

Deactivating a function







- Press the button .
 - ✓ The symbol disappears in the display and the next function appears.

3.29 Setting the clock



Condition

The motorcycle is stationary.

- Repeatedly press the button  briefly until **CLK** appears at the bottom right of the display.
- Press the button  for 2–3 seconds.
 - ✓ The hour display flashes.
- Adjust the hour display with the button  and/or button .
- Wait 3 - 5 seconds.
 - ✓ The next segment of the display flashes and can be set.
- You can set the following segments in the same way as the hours by pressing the button  and the button .



Info

The seconds can only be set to zero.

If no button is pressed for 15–20 seconds, or if an impulse comes from the wheel speed sensor, the settings are automatically saved and the setup menu is closed.



4 TECHNICAL DATA

4.1 Chassis tightening torques

Remaining screws, chassis	EJOT PT® K60x25-Z	2 Nm (1.5 lbf ft)
Screw, combination switch (EXC-F Six Days)	EJOT PT® K50x18 T20	2 Nm (1.5 lbf ft)
Screw, intake air temperature sensor	EJOT DELTA PT® 45x12-Z	0.7 Nm (0.52 lbf ft)
Screw, pressure regulator	EJOT PT® K60x25-Z	2.3 Nm (1.7 lbf ft)
Screw, seat fixing	EJOT EJOFORM PT® K60x23/18	2.5 Nm (1.84 lbf ft)
Screw, fixed grip	M4	5 Nm (3.7 lbf ft) Loctite®243™
Spoke nipple, front wheel	M4.5	6 Nm (4.4 lbf ft)
Spoke nipple, rear wheel	M4.5	6 Nm (4.4 lbf ft)
Remaining nuts, chassis	M5	5 Nm (3.7 lbf ft)
Remaining screws, chassis	M5	5 Nm (3.7 lbf ft)
Screw, battery terminal	M5	2.5 Nm (1.84 lbf ft)
Screw, light switch	M5	1 Nm (0.7 lbf ft)
Screw, turn signal switch	M5	1 Nm (0.7 lbf ft)
Nut, starter motor	M6	4 Nm (3 lbf ft)
Remaining nuts, chassis	M6	10 Nm (7.4 lbf ft)
Remaining screws, chassis	M6	10 Nm (7.4 lbf ft)
Screw, ball joint of push rod on foot brake cylinder	M6	10 Nm (7.4 lbf ft) Loctite®243™
Screw, chain sliding guard	M6	10 Nm (7.4 lbf ft) Loctite®243™
Screw, front brake disc	M6	14 Nm (10.3 lbf ft) Loctite®243™
Screw, rear brake disc	M6	14 Nm (10.3 lbf ft) Loctite®243™
Screw, throttle grip	M6	5 Nm (3.7 lbf ft)
Fuel connection on fuel pump	M8	15 Nm (11.1 lbf ft)
Nut, foot brake lever stop	M8	20 Nm (14.8 lbf ft)
Nut, rear sprocket screw	M8	35 Nm (25.8 lbf ft) Loctite®2701™
Nut, rim lock	M8	12 Nm (8.9 lbf ft)
Remaining nuts, chassis	M8	25 Nm (18.4 lbf ft)
Remaining screws, chassis	M8	25 Nm (18.4 lbf ft)
Screw, bottom triple clamp (EXC-F Six Days)	M8	15 Nm (11.1 lbf ft)
Screw, bottom triple clamp (EXC-F EU/BR)	M8	15 Nm (11.1 lbf ft)
Screw, chain sliding piece	M8	15 Nm (11.1 lbf ft)
Screw, engine brace on engine	M8x20	25 Nm (18.4 lbf ft) Loctite®243™
Screw, engine brace on frame	M8x15	25 Nm (18.4 lbf ft) Loctite®2701™
Screw, fork stub	M8	15 Nm (11.1 lbf ft)

Screw, front brake caliper	M8	25 Nm (18.4 lbf ft) Loctite®243™
Screw, handlebar clamp	M8	20 Nm (14.8 lbf ft)
Screw, manifold on cylinder head brace	M8	15 Nm (11.1 lbf ft)
Screw, side stand attachment	M8	33 Nm (24.3 lbf ft) Loctite®2701™
Screw, subframe bottom	M8	30 Nm (22.1 lbf ft) Loctite®2701™
Screw, subframe top	M8	35 Nm (25.8 lbf ft) Loctite®2701™
Screw, top steering stem (EXC-F Six Days)	M8	17 Nm (12.5 lbf ft) Loctite®243™
Screw, top steering stem (EXC-F EU/BR)	M8	20 Nm (14.8 lbf ft)
Screw, top triple clamp (EXC-F Six Days)	M8	17 Nm (12.5 lbf ft)
Screw, top triple clamp (EXC-F EU/BR)	M8	20 Nm (14.8 lbf ft)
Engine attachment bolt	M10	60 Nm (44.3 lbf ft)
Remaining nuts, chassis	M10	45 Nm (33.2 lbf ft)
Remaining screws, chassis	M10	45 Nm (33.2 lbf ft)
Screw, handlebar holder	M10	40 Nm (29.5 lbf ft) Loctite®243™
Nut, fuel pump fixation	M12	15 Nm (11.1 lbf ft)
Screw, bottom shock absorber	M12	80 Nm (59 lbf ft) Loctite®2701™
Screw, top shock absorber	M12	80 Nm (59 lbf ft) Loctite®2701™
Nut, fork pivot	M16x1.5	100 Nm (73.8 lbf ft)
Nut, rear wheel spindle	M20x1.5	80 Nm (59 lbf ft)
Screw, front wheel spindle	M20x1.5	35 Nm (25.8 lbf ft)
Screw, top steering head	M20x1.5	12 Nm (8.9 lbf ft)
Screw-in fitting, cooling system	M24x1.5	18 Nm (13.3 lbf ft) Loctite®243™

Super unleaded (ROZ 95)

Standard/classification

- DIN EN 228 (ROZ 95)

Guideline

- Only use super unleaded fuel that matches or is equivalent to the specified standard.
- Fuel with an ethanol content of up to 10% (E10 fuel) is safe to use.



Info

Do **not** use fuel containing methanol (e.g., M15, M85, M100) or more than 10% ethanol (e.g., E15, E25, E85, E100).

Super unleaded, type C (ROZ 95/RON 95/PON 91)

Standard/classification

- ANP (Agência Nacional do Petróleo) #57 (ROZ 95/RON 95/PON 91)

Guideline

- Only use super unleaded fuel that matches or is equivalent to the following specifications.
- Super unleaded fuel with an ethanol content of 19 to 27% is permissible.



Info

Do **not** use fuel made of methanol (e.g., M15, M85, M100).
Do **not** use fuel with less than 19% ethanol (e.g., E10).
Do **not** use fuel with more than 27% ethanol (e.g., E30, E85, E100).

Long-life grease

Recommended supplier

MOTOREX®

– Bike Grease 2000

**READY TO
RACE**



3214375en

02/2021



KTM Sportmotorcycle GmbH
5230 Mattighofen/Austria
KTM.com



REG. NO. 12 100 6061

Photo: Mitterbauer/KISKA/KTM