

## 1290 SUPER DUKE R

Art. no. 3214400en



**KTM**



Perform the work described in these setup instructions before the vehicle is delivered to the customer.

Read the setup instructions in their entirety before beginning work.

These setup instructions were written to correspond to the latest state of this series. We reserve the right to make changes in the interest of technical advancement without at the same time updating this manual. We shall not provide a description of general workshop methods. Likewise, safety rules that apply in a workshop are not specified here. It is assumed that the work will be performed by a fully trained mechanic.

All specifications contained herein are non-binding. KTM Sportmotorcycle GmbH specifically reserves the right to modify or delete technical specifications, prices, colors, forms, materials, services, designs, equipment, etc., without prior notice and without specifying reasons, to adapt these to local conditions, as well as to stop production of a particular model without prior notice. KTM accepts no liability for delivery options, deviations from figures and descriptions, misprints, and other errors. The models portrayed partly contain special equipment that does not belong to the regular scope of supply.

© 2021 KTM Sportmotorcycle GmbH, Mattighofen Austria

All rights reserved

Reproduction, even in part, as well as copying of all kinds, is permitted only with the express written permission of the copyright owner.



ISO 9001(12 100 6061)

KTM applies quality assurance processes that lead to the highest possible product quality as defined in the ISO 9001 international quality management standard.

Issued by: TÜV Management Service

REG.NO. 12 100 6061

KTM Sportmotorcycle GmbH  
Stallhofnerstraße 3  
5230 Mattighofen, Austria

This document is valid for the following models:

1290 SUPER DUKE R EU (F9903U9, F9903U2)

1290 SUPER DUKE R JP (F9986U9)

1290 SUPER DUKE R CN (F9987U9)

1290 SUPER DUKE R US (F9975U2, F9975U9)



# 1 MEANS OF REPRESENTATION

## 1.1 Symbols used

The meaning of specific symbols is described below.



Indicates an expected reaction (e.g. of a work step or a function).



Indicates an unexpected reaction (e.g. of a work step or a function).



Indicates a page reference (more information is provided on the specified page).



Indicates information with more details or tips.



Indicates the result of a testing step.



Indicates a voltage measurement.



Indicates a current measurement.



Indicates a resistance measurement.



Indicates the end of an activity including potential rework.

## 1.2 Formats used

The typographical formats used in this document are explained below.

**Proprietary name**

Indicates a proprietary name.

**Name®**

Indicates a protected name.

**Brand™**

Indicates a brand available on the open market.

**Underlined terms**

Refer to technical details of the vehicle or indicate technical terms, which are explained in the glossary.

## 2.1 Transport mode

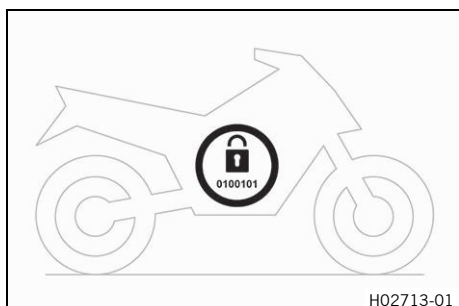

This vehicle was blocked for transport in the software. To operate the vehicle, the vehicle electronics must be enabled. This process is conducted during initial setup in KTM Dealer.net. Enabling ensures that the initial setup in KTM Dealer.net is documented.

Enabling can be performed either temporarily, e.g. for a test ride, or permanently for vehicle handover.

### **i** Info

Make sure that the vehicle is permanently enabled before handing it over to the customer.

## 2.2 Unpacking and setting up the vehicle

### Preliminary work

- Remove the box.

### Main work

- Remove the adhesive tape in the upper area of the motorcycle.



- Roll down the film at the sides.

### **i** Info

To avoid damaging the motorcycle during unpacking, leave the other films on the vehicle until you have finished work on the vehicle.

- Remove the separate enclosure and unpack it. Check that the scope of supply is complete using the enclosed packing list.

### **i** Info

The procedure for missing components is described in the Customer Service Manual.

- Check the vehicle for transport damage.

### **i** Info

The procedure in the event of transport damage is described in the Customer Service Manual.

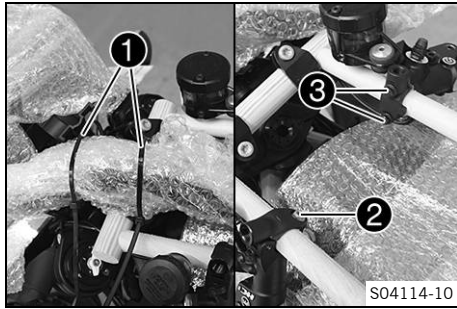

- Remove cable tie(s) **1**.
- Remove screws **2** and **3**.
- Take off the controls from the transport holder.

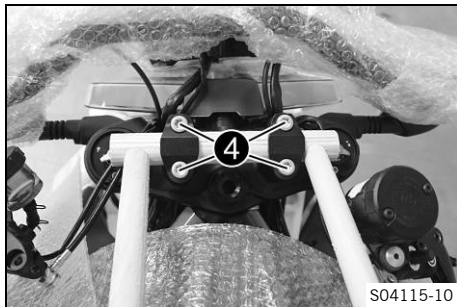

- Remove the handlebar clamp screws **4**.
- Take off the handlebar clamp and transport holder.



- Position the handlebar.
  - ✓ The markings of the handlebar scale are located centrally between the handlebar clamp.
- Position the handlebar clamp. Mount and tighten the screws evenly.

Guideline

Screw, handlebar clamp	M8	20 Nm (14.8 lbf ft)
------------------------	----	---------------------



- Position the brake assembly on the handlebar.
- Position brake assembly clamp on the handlebar.
  - ✓ The holding lug of the clamp engages in the combination switch.
- Mount and tighten screws **5**.

Guideline

Remaining screws, chassis	M6	10 Nm (7.4 lbf ft)
---------------------------	----	--------------------



- Position the clutch assembly on the handlebar.
- Mount and tighten screw **6**.

Guideline

Remaining screws, chassis	M6	10 Nm (7.4 lbf ft)
---------------------------	----	--------------------

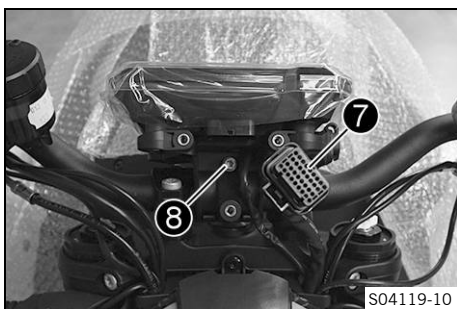

- Unplug connector 7.
- Position the combination instrument rack on the handlebar.
- Mount screw 8, but do not tighten yet.
- Move the combination instrument into the desired position.
- Tighten screw 8.

Guideline

Screw, combination instrument clamping	M6	2 Nm (1.5 lbf ft)
--	----	-------------------

- Plug in connector 7 with sleeve.
- Mount and tighten the rear mirror on both sides.



**(1290 SUPER DUKE R US)**

- Bond the reflectors on the right and left side of the reflector holder.
- Mount the reflector holder on license plate holder 9.



- Remove the passenger seat. (🛠️ p. 7)
- Secure tool set with the rubber strap.



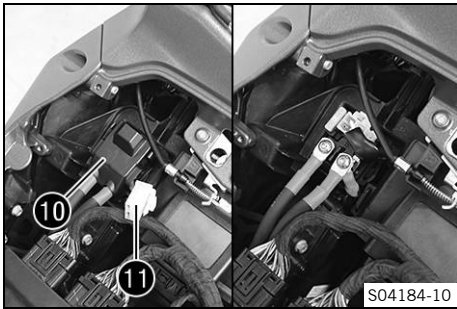

- Carefully loosen and remove the tension belts around the fork legs.
- ✓ The vehicle is released at the front.



### Info

An assistant prevents the motorcycle from falling over.

- Remove the cable ties on either side of the footrest.
- Together with an assistant, take the vehicle off the pallet.
- Remove the radiator shield.
- Remove the passenger seat. (📖 p. 7)
- Remove the front rider's seat. (📖 p. 7)
- Remove the black ignition key and **KEYCODECARD** and keep in a safe place for the handover.
- Remove cover **10**.
- Plug in the connector of starter relay **11**.
- Mount the cover.
- Charge the 12-V battery. (📖 p. 11)
- Remove the protective film.
- Refuel. (📖 p. 13)
- Prepare the vehicle according to the specifications in **KTM Dealer.net** for handover to the customer.

### 3.1 Removing the passenger seat

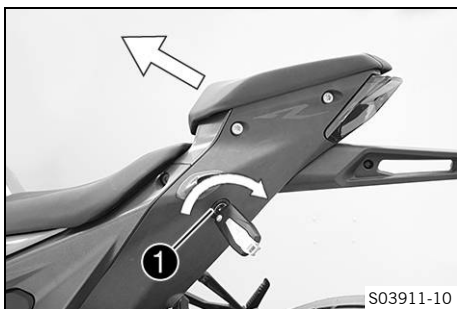

- Insert the RACE-ON key or the black ignition key into seat lock ① and turn clockwise.
- Lift passenger seat at the front and pull it out of the bracket toward the front.
- Remove the passenger seat.
- Remove the ignition key.



### 3.2 Mounting the passenger seat

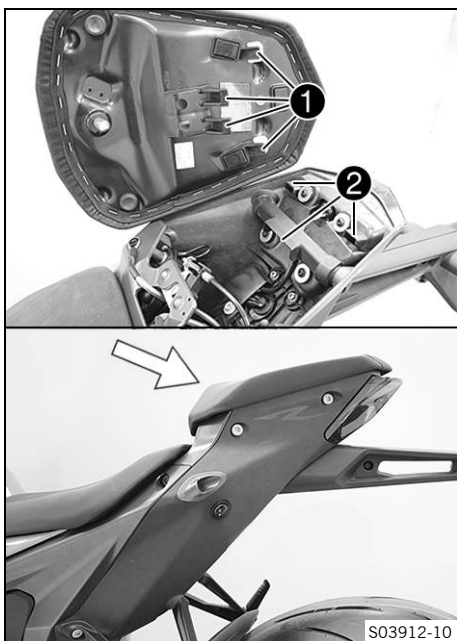

- Hook recesses ① of the passenger seat in guides ② and lower the front seat while pushing it back.
- Position the locking pin in the lock housing and push the passenger seat down at the front.
- ✓ The locking pin engages with an audible click.
- Check that the passenger seat is mounted correctly.



### 3.3 Removing the front rider's seat

#### Preparatory work

- Remove the passenger seat. (📖 p. 7)

#### Main work

- Unlock the front rider's seat with loop ① underneath the passenger seat.
- Raise the front rider's seat at the rear and remove it.

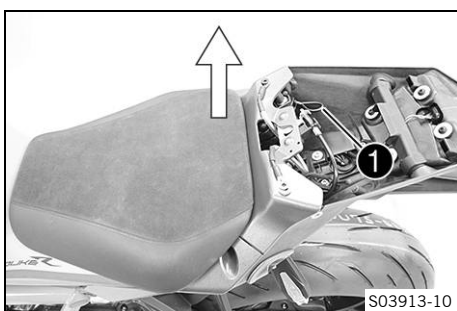

### 3.4 Mounting the front rider's seat

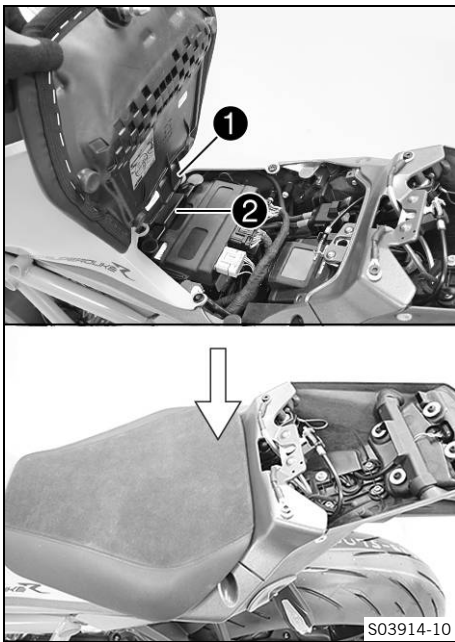

#### Main work

- Hook recess ① of the front rider's seat into guide ②, lower it at the rear and push it forward.
- Position the locking pin in the lock housing and push the passenger seat down at the front.
- ✓ The locking pin engages with an audible click.
- Check that the front rider's seat is mounted correctly.

#### Finishing work

- Mount the passenger seat. (📖 p. 7)

### 3.5 Removing the 12-V battery



#### Warning

**Risk of injury** Battery acid and battery gases cause serious chemical burns.

- Keep 12 V batteries out of the reach of children.
- Wear suitable protective clothing and safety glasses.
- Avoid contact with battery acid and battery gases.
- Keep sparks or open flames away from the 12 V battery.
- Only charge 12 V batteries in well-ventilated rooms.
- Rinse the affected area immediately with plenty of water in the event of contact with the skin.
- Rinse eyes with water for at least 15 minutes and consult a doctor immediately if battery acid and battery gases get into the eyes.



#### Caution

**Danger of accidents** Electronic components and safety devices will be damaged if the 12-V battery is discharged or missing.

If the 12-V battery is discharged or defective, malfunctions in the vehicle electronics can occur, especially when starting.

- Never operate the vehicle with a discharged 12-V battery or without a 12-V battery.

#### Preparatory work

- Remove the passenger seat. (📖 p. 7)
- Remove the front rider's seat. (📖 p. 7)

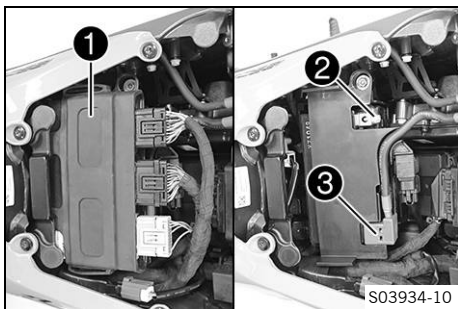

**Main work**

- Remove control unit ① and hang to the side.
- Disconnect negative cable ② from the 12-V battery.
- Remove positive terminal cover ③ and disconnect the positive cable from the 12-V battery.

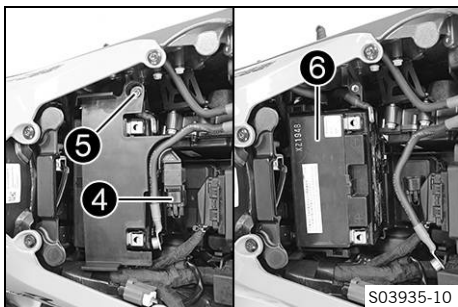

- Disconnect connector ④.
- Remove screw ⑤ and take off the battery cover.
- Take the 12-V battery ⑥ out of the battery compartment.

**3.6 Installing the 12-V battery**

**Warning**  
**Risk of injury** Battery acid and battery gases cause serious chemical burns.

- Keep 12 V batteries out of the reach of children.
- Wear suitable protective clothing and safety glasses.
- Avoid contact with battery acid and battery gases.
- Keep sparks or open flames away from the 12 V battery.
- Only charge 12 V batteries in well-ventilated rooms.
- Rinse the affected area immediately with plenty of water in the event of contact with the skin.
- Rinse eyes with water for at least 15 minutes and consult a doctor immediately if battery acid and battery gases get into the eyes.

**Caution**  
**Danger of accidents** Electronic components and safety devices will be damaged if the 12-V battery is discharged or missing.

If the 12-V battery is discharged or defective, malfunctions in the vehicle electronics can occur, especially when starting.

- Never operate the vehicle with a discharged 12-V battery or without a 12-V battery.

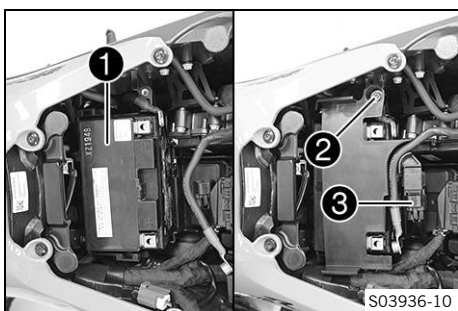

**Main work**

- Insert 12-V battery ① into the battery compartment.

12-V battery (YTX14-BS)
-------------------------

- Position the battery cover, mount screw ②, and tighten.

Guideline		
Remaining screws, chassis	M5	5 Nm (3.7 lbf ft)

- Join connector ③.

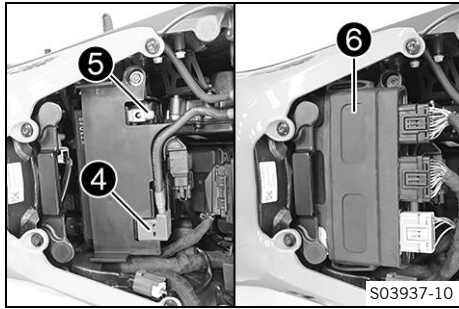

- Position the positive cable and mount and tighten the screw.

Guideline

Screw, battery terminal	M6	4.5 Nm (3.32 lbf ft)
-------------------------	----	-------------------------

- Mount positive terminal cover (4).
- Position negative cable (5) and mount and tighten the screw.

Guideline

Screw, battery terminal	M6	4.5 Nm (3.32 lbf ft)
-------------------------	----	-------------------------

- Position control unit (6).

### Finishing work

- Mount the front rider's seat. (📖 p. 8)
- Mount the passenger seat. (📖 p. 7)
- Set time and date.

## 3.7 Disconnecting the negative cable of the 12-V battery



### Warning

**Risk of injury** Battery acid and battery gases cause serious chemical burns.

- Keep 12 V batteries out of the reach of children.
- Wear suitable protective clothing and safety glasses.
- Avoid contact with battery acid and battery gases.
- Keep sparks or open flames away from the 12 V battery.
- Only charge 12 V batteries in well-ventilated rooms.
- Rinse the affected area immediately with plenty of water in the event of contact with the skin.
- Rinse eyes with water for at least 15 minutes and consult a doctor immediately if battery acid and battery gases get into the eyes.



### Caution

**Danger of accidents** Electronic components and safety devices will be damaged if the 12-V battery is discharged or missing.

If the 12-V battery is discharged or defective, malfunctions in the vehicle electronics can occur, especially when starting.

- Never operate the vehicle with a discharged 12-V battery or without a 12-V battery.

### Preparatory work

- Remove the passenger seat. (📖 p. 7)
- Remove the front rider's seat. (📖 p. 7)

### Main work

- Remove control unit (1) and hang to the side.
- Disconnect negative cable (2) from the 12-V battery.

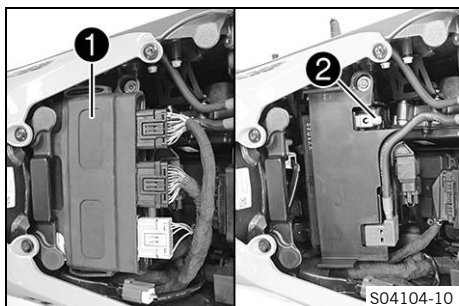

### 3.8 Connecting the negative cable of the 12-V battery



**Warning**

**Risk of injury** Battery acid and battery gases cause serious chemical burns.

- Keep 12 V batteries out of the reach of children.
- Wear suitable protective clothing and safety glasses.
- Avoid contact with battery acid and battery gases.
- Keep sparks or open flames away from the 12 V battery.
- Only charge 12 V batteries in well-ventilated rooms.
- Rinse the affected area immediately with plenty of water in the event of contact with the skin.
- Rinse eyes with water for at least 15 minutes and consult a doctor immediately if battery acid and battery gases get into the eyes.



**Caution**

**Danger of accidents** Electronic components and safety devices will be damaged if the 12-V battery is discharged or missing.

If the 12-V battery is discharged or defective, malfunctions in the vehicle electronics can occur, especially when starting.

- Never operate the vehicle with a discharged 12-V battery or without a 12-V battery.

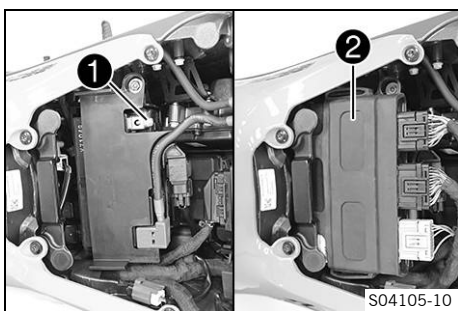

**Main work**

- Position negative cable ① and mount and tighten the screw.

Guideline

Screw, battery terminal	M6	4.5 Nm (3.32 lbf ft)
-------------------------	----	-------------------------

- Position control unit ②.

**Finishing work**

- Mount the front rider's seat. (🔧 p. 8)
- Mount the passenger seat. (🔧 p. 7)
- Set time and date.



### 3.9 Charging the 12-V battery



**Warning**

**Risk of injury** Battery acid and battery gases cause serious chemical burns.

- Keep 12 V batteries out of the reach of children.
- Wear suitable protective clothing and safety glasses.
- Avoid contact with battery acid and battery gases.
- Keep sparks or open flames away from the 12 V battery.
- Only charge 12 V batteries in well-ventilated rooms.
- Rinse the affected area immediately with plenty of water in the event of contact with the skin.
- Rinse eyes with water for at least 15 minutes and consult a doctor immediately if battery acid and battery gases get into the eyes.



**Note**

**Environmental hazard** 12 V batteries contain environmentally hazardous materials.

- Do not dispose of 12 V batteries as household waste.
- Dispose of 12 V batteries at a collection point for used batteries.



**Note**

**Environmental hazard** Hazardous substances cause environmental damage.

- Dispose of oils, grease, filters, fuel, cleaning agents, brake fluid, etc., correctly and in compliance with the applicable regulations.



**Info**

Even when there is no load on the 12-V battery, it discharges steadily each day. The charging level and the method of charging are very important for the service life of the 12-V battery. Rapid recharging with a high charging current shortens the service life of the battery. If the charging current, charging voltage, and charging time are exceeded, the 12-V battery will be destroyed. If the 12-V battery is depleted from starting the vehicle repeatedly, the battery must be charged immediately. If the 12-V battery is left in a discharged state for an extended period, it will become deeply discharged and sulfating occurs, destroying the battery. The 12-V battery is maintenance-free, i.e. the acid level does not have to be checked.

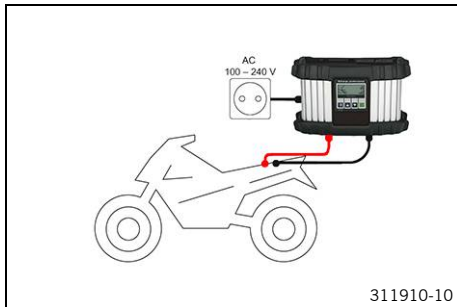

**Preparatory work**

- Remove the passenger seat. (📖 p. 7)
- Remove the front rider's seat. (📖 p. 7)
- Disconnect the negative cable of the 12-V battery. (📖 p. 10)

**Main work**

- Connect a battery charger to the 12-V battery. Adjust the battery charger.

EU battery charger **XCharge-professional** (00029095050)

**Alternative 1**

US battery charger **XCharge-professional** (00029095051)

**Alternative 2**

UK battery charger **XCharge-professional** (00029095052)



**Info**

Follow the instructions of the charger and the manual.

- Disconnect the battery charger after charging the 12-V battery.

**Guideline**

The charging current, charging voltage, and charging time must not be exceeded.	
Recharge the 12-V battery regularly when the motorcycle is not being used	3 months

**Finishing work**

- Connect the negative cable of the 12-V battery. (📖 p. 11)
- Mount the front rider's seat. (📖 p. 8)
- Mount the passenger seat. (📖 p. 7)

- Set time and date.



### 3.10 Refueling



#### **Danger**

**Fire hazard** Fuel is highly flammable.

The fuel in the fuel tank expands when warm and can escape if overfilled.

- Do not fuel the vehicle in the vicinity of open flames or lit cigarettes.
- Switch off the engine for refueling.
- Make sure that no fuel is spilled; particularly not on hot parts of the vehicle.
- If any fuel is spilled, wipe it off immediately.
- Observe the specifications for refueling.



#### **Warning**

**Danger of poisoning** Fuel is poisonous and a health hazard.

- Avoid skin, eye and clothing contact with fuel.
- Immediately consult a doctor if you swallow fuel.
- Do not inhale fuel vapors.
- In case of skin contact, rinse the affected area with plenty of water.
- Rinse the eyes thoroughly with water, and consult a doctor in case of fuel contact with the eyes.
- Change your clothing in case of fuel spills on them.

#### **Note**

**Material damage** Inadequate fuel quality causes the fuel filter to quickly become clogged.

In some countries and regions, the available fuel quality and cleanliness may not be sufficient. This will result in problems with the fuel system.

- Refuel only with clean fuel that meets the specified standards.



#### **Note**

**Environmental hazard** Improper handling of fuel is a danger to the environment.

- Do not allow fuel to enter the groundwater, the soil, or the sewage system.



- Switch off the engine.
- Open fuel tank filler cap. (📖 p. 14)
- Fill the fuel tank with fuel up to the lower edge **A** of the filler neck.

Total fuel tank capacity, approx.	16 l (4.2 US gal)	Super unleaded (ROZ 95) (📖 p. 21)
-----------------------------------	----------------------	--------------------------------------

- Close the fuel tank filler cap. (📖 p. 15)

## 3.11 Opening fuel tank filler cap



### Danger

**Fire hazard** Fuel is highly flammable.

The fuel in the fuel tank expands when warm and can escape if overfilled.

- Do not fuel the vehicle in the vicinity of open flames or lit cigarettes.
- Switch off the engine for refueling.
- Make sure that no fuel is spilled; particularly not on hot parts of the vehicle.
- If any fuel is spilled, wipe it off immediately.
- Observe the specifications for refueling.



### Warning

**Danger of poisoning** Fuel is poisonous and a health hazard.

- Avoid skin, eye and clothing contact with fuel.
- Immediately consult a doctor if you swallow fuel.
- Do not inhale fuel vapors.
- In case of skin contact, rinse the affected area with plenty of water.
- Rinse the eyes thoroughly with water, and consult a doctor in case of fuel contact with the eyes.
- Change your clothing in case of fuel spills on them.
- Keep fuels correctly in a suitable canister, and out of the reach of children.



### Note

**Environmental hazard** Improper handling of fuel is a danger to the environment.

- Do not allow fuel to enter the groundwater, the soil, or the sewage system.

### Condition

The motorcycle is stationary.

The engine is switched off.

The ignition has been switched on or off for less than 1 minute.

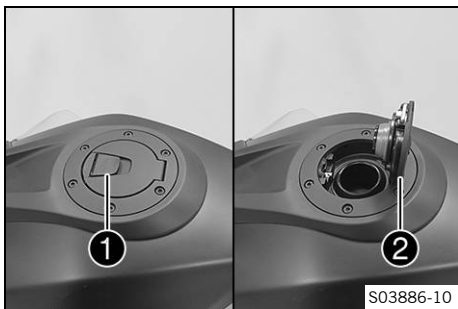

- Fold up cover ① slowly.
- ✓ The fuel tank filler cap is unlocked.
- Fold up fuel tank filler cap ②.

### 3.12 Closing the fuel tank filler cap

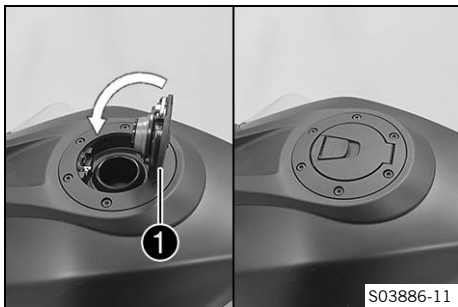

#### Warning

**Fire hazard** Fuel is highly flammable, toxic and a health hazard.

- Check that the fuel tank filler cap is locked correctly after closing.
- Change your clothing if fuel spills on them.
- Rinse the affected area immediately with plenty of water in the event of contact with the skin.

- Fold down fuel tank filler cap ① and push it down.
- ✓ The fuel tank filler cap locks audibly in place.

### 3.13 Setting the time and date

#### Condition

The motorcycle is stationary.

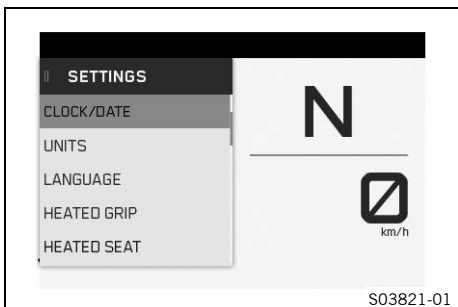

- Press **RIGHT** button when the menu is closed.
- Press the **UP** or **DOWN** button until **Settings** is marked.
- ✓ Press the **RIGHT** button to open the menu.
- Press the **UP** or **DOWN** button until **Clock/Date** is marked.
- ✓ Press the **RIGHT** button to open the menu.

#### Setting the clock

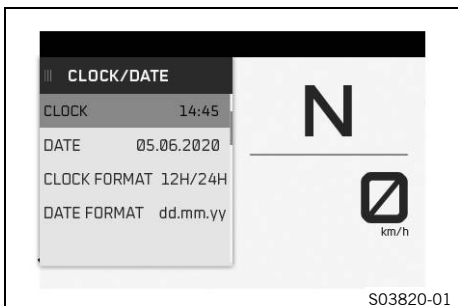

- Press the **UP** or **DOWN** button until the time is marked.
- Press the **SET** button.
- ✓ The hour next to **Clock** flashes.
- Press the **UP** or **DOWN** button until the current hour is set.
- Press the **RIGHT** button.
- ✓ The minute next to **Clock** flashes.
- Press the **UP** or **DOWN** button until the current minute is set.
- Press the **SET** button.
- ✓ The time is stored.

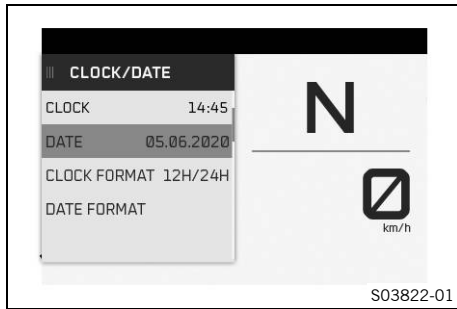

## Setting the date

- Press the **UP** or **DOWN** button until the date is marked.
- Press the **SET** button.
  - ✓ The day next to **Date** flashes.
- Press the **UP** or **DOWN** button until the current day is set.
- Press the **RIGHT** button.
  - ✓ The month next to **Date** flashes.
- Press the **UP** or **DOWN** button until the current month is set.
- Press the **RIGHT** button.
  - ✓ The year next to **Date** flashes.
- Press the **UP** or **DOWN** button until the current year is set.
- Press the **SET** button.
  - ✓ The date is stored.

**4.1 Chassis tightening torques**

Remaining screws, chassis	<b>EJOT PT®</b> K50x12	1 Nm (0.7 lbf ft)
Remaining screws, chassis	<b>EJOT PT®</b> K50x14	1 Nm (0.7 lbf ft)
Remaining screws, chassis	<b>EJOT PT®</b> K50x16	2 Nm (1.5 lbf ft)
Remaining screws, chassis	<b>EJOT PT®</b> K50x18	2 Nm (1.5 lbf ft)
Remaining screws, chassis	<b>EJOT PT®</b> K45x12	1 Nm (0.7 lbf ft)
Screw, air filter box cover	<b>EJOT PT®</b> K60x30	2.5 Nm (1.84 lbf ft)
Screw, exhaust valve cover fastening	<b>EJOT SF®</b> M4x6-K	4 Nm (3 lbf ft)
Screw, tail light	<b>EJOT PT®</b> K50x14	2.5 Nm (1.84 lbf ft)
Screw, fixed grip, left	M4	3 Nm (2.2 lbf ft)
Screw, side stand sensor	M4	2 Nm (1.5 lbf ft)
Remaining nuts, chassis	M5	5 Nm (3.7 lbf ft)
Remaining screws, chassis	M5	5 Nm (3.7 lbf ft)
Screw for throttle grip	M5	3.5 Nm (2.58 lbf ft)
screw, absorbing element, combination instrument	M5	2 Nm (1.5 lbf ft) <b>Loctite®243™</b>
Screw, cable channel	M5	5 Nm (3.7 lbf ft)
Screw, chain sliding guard	M5	5 Nm (3.7 lbf ft)
Screw, combination instrument	M5	1 Nm (0.7 lbf ft)
Screw, combination switch, left	M5	5 Nm (3.7 lbf ft)
Screw, combination switch, right	M5	5 Nm (3.7 lbf ft)
Screw, front turn signal bracket	M5	3.5 Nm (2.58 lbf ft)
Screw, fuel level sensor	M5	3 Nm (2.2 lbf ft)
Screw, fuel tank filler cap	M5	3 Nm (2.2 lbf ft)
Screw, rear turn signal bracket	M5	3.5 Nm (2.58 lbf ft)
Screw, trim	M5	3.5 Nm (2.58 lbf ft)
Cable disk nut, exhaust valve control unit	M6	14 Nm (10.3 lbf ft)
Ground fitting on frame	M6	10 Nm (7.4 lbf ft)
Nut, cable on starter motor	M6	4 Nm (3 lbf ft)
Remaining nuts, chassis	M6	10 Nm (7.4 lbf ft)
Remaining screws, chassis	M6	10 Nm (7.4 lbf ft)
Screw, 6-D sensor cover	M6	6 Nm (4.4 lbf ft) <b>Loctite®243™</b>
Screw, ABS module fastening	M6	8 Nm (5.9 lbf ft)
Screw, ball joint of push rod on foot brake cylinder	M6	5 Nm (3.7 lbf ft) <b>Loctite®243™</b>
Screw, battery terminal	M6	4.5 Nm (3.32 lbf ft)
Screw, clutch assembly	M6	5 Nm (3.7 lbf ft) <b>Loctite®243™</b>
Screw, connecting piece, rear brake line	M6	10 Nm (7.4 lbf ft) <b>Loctite®243™</b>
Screw, cooler retaining bracket	M6	7 Nm (5.2 lbf ft)
Screw, exhaust clamp on main silencer	M6	10 Nm (7.4 lbf ft)

## 4 TECHNICAL DATA

Screw, foot brake cylinder	M6	10 Nm (7.4 lbf ft) <b>Loctite®243™</b>
Screw, front wheel speed sensor	M6	4 Nm (3 lbf ft)
Screw, fuel pump	M6	6 Nm (4.4 lbf ft)
Screw, fuel tank cover	M6	5 Nm (3.7 lbf ft)
Screw, instrument support	M6	2 Nm (1.5 lbf ft)
Screw, license plate holder on lower rear panel	M6	8 Nm (5.9 lbf ft)
Screw, presilencer exhaust clamp	M6	10 Nm (7.4 lbf ft)
Screw, radiator hose clip	M6	3 Nm (2.2 lbf ft)
Screw, rear wheel speed sensor	M6	4 Nm (3 lbf ft)
Screw, shift lever stub	M6	10 Nm (7.4 lbf ft)
Screw, shift rod	M6	5 Nm (3.7 lbf ft) <b>Loctite®243™</b>
Screw, shift shaft deflector on shift shaft	M6	18 Nm (13.3 lbf ft) <b>Loctite®243™</b>
Screw, side stand stub	M6	6 Nm (4.4 lbf ft) <b>Loctite®243™</b>
Screw, steering damper bracket on frame	M6	8 Nm (5.9 lbf ft) <b>Loctite®243™</b>
Screw, step plate for foot brake lever	M6	10 Nm (7.4 lbf ft)
Nut, exhaust valve throttle cable	M6x1	5 Nm (3.7 lbf ft)
Cable disk nut, exhaust valve	M8	7 Nm (5.2 lbf ft)
Nut, rear sprocket	M8	36 Nm (26.6 lbf ft) <b>Loctite®243™</b>
Nut, shift rod	M8	12 Nm (8.9 lbf ft)
Nut, valve (1290 SUPER DUKE R JP, 1290 SUPER DUKE R CN)	M8	4 Nm (3 lbf ft)
Nut, valve (1290 SUPER DUKE R EU, 1290 SUPER DUKE R US)	M8	6 Nm (4.4 lbf ft) <b>Loctite®243™</b>
Remaining nuts, chassis	M8	25 Nm (18.4 lbf ft)
Remaining screws, chassis	M8	25 Nm (18.4 lbf ft)
Screw, axle clamp	M8	15 Nm (11.1 lbf ft)
Screw, bottom triple clamp	M8	15 Nm (11.1 lbf ft)
Screw, foot brake lever	M8	20 Nm (14.8 lbf ft) <b>Loctite®243™</b>
Screw, front brake disc	M8	28 Nm (20.7 lbf ft) <b>Loctite®2701™</b>
Screw, front rider footrest bracket	M8	25 Nm (18.4 lbf ft) <b>Loctite®243™</b>
Screw, handlebar clamp	M8	20 Nm (14.8 lbf ft)
Screw, ignition lock (tamper-proof screw)	M8	25 Nm (18.4 lbf ft)
Screw, rear brake caliper	M8	25 Nm (18.4 lbf ft) <b>Loctite®2701™</b>

Screw, rear brake disc	M8	28 Nm (20.7 lbf ft) <b>Loctite®243™</b>
Screw, shift lever on footrest bracket	M8	20 Nm (14.8 lbf ft) <b>Loctite®243™</b>
Screw, shift shaft deflector on frame	M8	10 Nm (7.4 lbf ft) <b>Loctite®243™</b>
Screw, side stand bracket	M8	25 Nm (18.4 lbf ft) <b>Loctite®243™</b>
Screw, side stand spring	M8	15 Nm (11.1 lbf ft) <b>Loctite®2701™</b>
Screw, steering damper on holder	M8	8 Nm (5.9 lbf ft) <b>Loctite®243™</b>
Screw, steering damper on triple clamp	M8	8 Nm (5.9 lbf ft) <b>Loctite®243™</b>
Screw, steering stem clamp	M8	20 Nm (14.8 lbf ft) <b>Loctite®243™</b>
Screw, top triple clamp	M8	18 Nm (13.3 lbf ft)
Remaining nuts, chassis	M10	45 Nm (33.2 lbf ft)
Remaining screws, chassis	M10	45 Nm (33.2 lbf ft)
Screw, engine bearer	M10	45 Nm (33.2 lbf ft) <b>Loctite®243™</b>
Screw, front brake caliper	M10	45 Nm (33.2 lbf ft) <b>Loctite®243™</b>
Screw, handlebar support	M10	40 Nm (29.5 lbf ft) <b>Loctite®243™</b>
Screw, side stand	M10	40 Nm (29.5 lbf ft) <b>Loctite®243™</b>
Screw, side stand bracket	M10	55 Nm (40.6 lbf ft) <b>Loctite®243™</b>
Banjo bolt, brake line	M10x1	25 Nm (18.4 lbf ft)
Banjo bolt, brake line, connecting piece, rear	M10x1	25 Nm (18.4 lbf ft)
Nut, rear hub shock absorber carrier	M10x1.25	45 Nm (33.2 lbf ft) <b>Loctite®243™</b>
Screw, bottom shock absorber	M12	80 Nm (59 lbf ft) <b>Loctite®243™</b>
Screw, side stand bracket	M12	80 Nm (59 lbf ft) <b>Loctite®243™</b>
Screw, top shock absorber	M12	80 Nm (59 lbf ft) <b>Loctite®243™</b>
Lambda sensor	M12x1.25	24.5 Nm (18.07 lbf ft)
Screw, eccentric	M16	70 Nm (51.6 lbf ft)
Nut, fork pivot	M19x1.5	130 Nm (95.9 lbf ft) Thread greased
Screw, steering head, top	M20x1.5	12 Nm (8.9 lbf ft)
Nut, seat lock	M22x1.5	3 Nm (2.2 lbf ft)
Screw, front wheel spindle	M25x1.5	45 Nm (33.2 lbf ft) Thread greased

## 4 TECHNICAL DATA

Nut, rear axle, shock absorber side	M35x1.5	200 Nm (147.5 lbf ft) <b>Loctite® 262™</b> /lock the locking wire with locking varnish
Nut, rear axle	M50x1.5	250 Nm (184.4 lbf ft) Thread greased/lock locking wire with locking varnish

## Super unleaded (ROZ 95)

### Standard/classification

- DIN EN 228 (ROZ 95)

### Guideline

- Only use super unleaded fuel that matches or is equivalent to the specified standard.
  - Fuel with an ethanol content of up to 10% (E10 fuel) is safe to use.
- 



### Info

Do **not** use fuel containing methanol (e.g., M15, M85, M100) or more than 10% ethanol (e.g., E15, E25, E85, E100).

---



3214400en

01/2021

