

890 ADVENTURE R

ART. NO. 3214536EN



Congratulations on your decision to purchase a KTM motorcycle. You are now the owner of a state-of-the-art sports vehicle which, with appropriate care, will bring you pleasure for a long time to come.

We wish you good and safe riding at all times!

Please enter the serial numbers of your vehicle below.

Vehicle identification number (📖 p. 14)	Dealer's stamp
Engine number (📖 p. 15)	
Key number (📖 p. 14)	

The Owner's Manual contained the latest information for this model series at the time of publication. However, minor differences due to further developments in design cannot be ruled out completely.

All specifications contained herein are non-binding. KTM Sportmotorcycle GmbH specifically reserves the right to modify or delete technical specifications, prices, colors, forms, materials, services, designs, equipment, etc., without prior notice and without specifying reasons, to adapt these to local conditions, as well as to stop production of a particular model without prior notice. KTM accepts no liability for delivery options, deviations from figures and descriptions, misprints, and other errors. The models portrayed partly contain special equipment that does not belong to the regular scope of supply.

© 2021 KTM Sportmotorcycle GmbH, Mattighofen Austria

All rights reserved

Reproduction, even in part, as well as copying of all kinds, is permitted only with the express written permission of the copyright owner.



ISO 9001(12 100 6061)

KTM applies quality assurance processes that lead to the highest possible product quality as defined in the ISO 9001 international quality management standard.

Issued by: TÜV Management Service

REG.NO. 12 100 6061

KTM Sportmotorcycle GmbH
Stallhofnerstraße 3
5230 Mattighofen, Austria

This document is valid for the following models:

890 ADVENTURE R EU (F9703V7)



3214536en

09/2021

TABLE OF CONTENTS

1	MEANS OF REPRESENTATION	6	6.5	Switches on the right side of the handlebar.....	19
1.1	Symbols used	6	6.5.1	Start button/emergency OFF switch.....	19
1.2	Formats used.....	6	6.6	Ignition and steering lock.....	20
2	SAFETY ADVICE.....	7	6.7	Locking the steering.....	20
2.1	Use definition – intended use.....	7	6.8	Unlocking the steering.....	20
2.2	Misuse.....	7	6.9	Socket for electrical accessories	21
2.3	Safety advice.....	7	6.10	Opening the fuel tank filler cap	21
2.4	Degrees of risk and symbols.....	7	6.11	Closing the fuel tank filler cap.....	22
2.5	Tampering warning.....	8	6.12	Fuel cocks.....	22
2.6	Safe operation	8	6.13	Opening the storage compartment on the left.....	22
2.7	Protective clothing	9	6.14	Closing the storage compartment on the left.....	23
2.8	Work rules.....	9	6.15	Opening the storage compartment on the right.....	24
2.9	Environment.....	9	6.16	Closing the storage compartment on the right.....	24
2.10	Owner's Manual	9	6.17	Tool set.....	25
3	IMPORTANT NOTES.....	11	6.18	Grab handles	25
3.1	Manufacturer warranty, implied warranty.....	11	6.19	Luggage rack plate.....	25
3.2	Fuel, auxiliary substances.....	11	6.20	Seat lock.....	25
3.3	Spare parts, technical accessories	11	6.21	Passenger foot pegs	26
3.4	Service	11	6.22	Shift lever	26
3.5	Figures	11	6.23	Foot brake lever	26
3.6	Customer service.....	11	6.24	Side stand.....	27
4	VIEW OF VEHICLE	12	7	COMBINATION INSTRUMENT	28
4.1	View of vehicle, front left (example) ...	12	7.1	Combination instrument	28
4.2	View of vehicle, rear right (example).....	13	7.2	Activation and test	28
5	SERIAL NUMBERS	14	7.3	Day-night mode	28
5.1	Vehicle identification number.....	14	7.4	Warnings.....	29
5.2	Type label	14	7.5	Ice warning	29
5.3	Key number.....	14	7.6	Indicator lamps.....	30
5.4	Engine number	15	7.7	Display	31
5.5	Fork part number	15	7.8	Rally display (optional)	32
5.6	Shock absorber article number	15	7.9	Speed	33
5.7	Steering damper article number	15	7.10	Shift warning light	33
6	CONTROLS.....	16	7.11	Speedometer	33
6.1	Clutch lever.....	16	7.12	Heated grip (optional).....	34
6.2	Hand brake lever.....	16	7.13	Seat heating (optional)	34
6.3	Throttle grip	16	7.14	Ride display	34
6.4	Switches on the left side of the handlebar.....	16	7.15	ABS display.....	34
6.4.1	Combination switch.....	16	7.16	MTC display	35
6.4.2	Light switch	17	7.17	Cruise control indicator (optional)	35
6.4.3	Cruise control system tip switch	17	7.18	Coolant temperature indicator	35
6.4.4	Menu buttons.....	18	7.19	Fuel level display	36
6.4.5	Turn signal switch.....	19	7.20	Ambient air temperature indicator	36
6.4.6	Horn button	19	7.21	Time.....	36
			7.22	Favorites display	37
			7.23	Quick Selector 1 display	37
			7.24	Quick Selector 2 display	37
			7.25	Navigation display.....	37



7.26	Menu.....	38	8	ERGONOMICS	60
7.26.1	KTM MY RIDE	38	8.1	Handlebar position	60
7.26.2	Audio	38	8.2	Adjusting the handlebar position 	60
7.26.3	Navigation.....	39	8.3	Adjusting the windshield	61
7.26.4	Pairing.....	39	8.4	Adjusting the basic position of the clutch lever	61
7.26.5	Phone.....	40	8.5	Adjusting the basic position of the hand brake lever	62
7.26.6	Headset	41	8.6	Adjusting foot brake lever stub	62
7.26.7	Telephony	42	8.7	Adjusting the basic position of the foot brake lever 	63
7.26.8	Trips/Data	42	8.8	Checking the basic position of the shift lever	64
7.26.9	General Info	43	8.9	Adjusting the basic position of the shift lever 	64
7.26.10	Trip 1	43	9	PREPARING FOR USE.....	65
7.26.11	Trip 2	43	9.1	Advice on preparing for first use	65
7.26.12	TPMS (function optional).....	44	9.2	Running in the engine	66
7.26.13	Warning	45	9.3	Loading the vehicle	66
7.26.14	Ride Mode	45	10	RIDING INSTRUCTIONS	68
7.26.15	Ride Mode	45	10.1	Checks and maintenance measures when preparing for use	68
7.26.16	Rally (optional).....	46	10.2	Starting the vehicle	68
7.26.17	Throttle Response (optional)	47	10.3	Starting off.....	69
7.26.18	Leave Rally (optional).....	47	10.4	Quickshifter + (optional)	69
7.26.19	Motorcycle	48	10.5	Shifting, riding	70
7.26.20	MTC	48	10.6	MSR (optional)	73
7.26.21	MTC+MSR (optional).....	49	10.7	Applying the brakes.....	73
7.26.22	ABS.....	49	10.8	Stopping, parking.....	74
7.26.23	Heating Grip (function optional)	50	10.9	Transporting.....	75
7.26.24	Heating Seat Rider (function optional)	50	10.10	Towing in the event of a breakdown ...	75
7.26.25	Quick Shift+ (optional)	50	10.11	Refueling	76
7.26.26	Settings	51	11	SERVICE SCHEDULE	78
7.26.27	Favorites	51	11.1	Additional information	78
7.26.28	Quick Selector 1	51	11.2	Required work	78
7.26.29	Quick Selector 2.....	52	11.3	Recommended work	79
7.26.30	Bluetooth	52	12	TUNING THE CHASSIS	80
7.26.31	Display Theme.....	52	12.1	Fork/shock absorber	80
7.26.32	Shift Light	53	12.2	Adjusting the compression damping of the fork	80
7.26.33	RPM1	53	12.3	Adjusting the rebound damping of the fork	81
7.26.34	RPM2	53	12.4	Adjusting the spring preload of the fork	81
7.26.35	Shift Light	54	12.5	Compression damping of the shock absorber.....	82
7.26.36	Setting the time and date	54	12.6	Adjusting the low-speed compression damping of the shock absorber.....	82
7.26.37	DRL	55			
7.26.38	Units	56			
7.26.39	Distance	56			
7.26.40	Temperature.....	56			
7.26.41	Fuel Cons.....	56			
7.26.42	Language	57			
7.26.43	Heating (function optional)	57			
7.26.44	Heating Grip (function optional)	57			
7.26.45	Heating Seat Rider (function optional)	58			
7.26.46	Heating Seat Pillion (function optional)	58			
7.26.47	Service	58			
7.26.48	Extra Functions	59			

TABLE OF CONTENTS

12.7	Adjusting the high-speed compression damping of the shock absorber.....	83	14.3	Checking the front brake fluid level	110
12.8	Adjusting the rebound damping of the shock absorber.....	84	14.4	Adding front brake fluid 🛠️.....	110
12.9	Adjusting the spring preload of the shock absorber 🛠️.....	84	14.5	Checking the front brake linings	111
13	SERVICE WORK ON THE CHASSIS.....	86	14.6	Checking the free travel of the foot brake lever	112
13.1	Raising the motorcycle with rear lifting gear	86	14.7	Checking the rear brake fluid level	112
13.2	Removing the rear of the motorcycle from the lifting gear	86	14.8	Adding rear brake fluid 🛠️.....	113
13.3	Lifting the motorcycle with the front lifting gear	86	14.9	Checking the rear brake linings	114
13.4	Taking the motorcycle off the front lifting gear	87	15	WHEELS, TIRES	115
13.5	Removing the seat	87	15.1	Removing the front wheel 🛠️.....	115
13.6	Mounting the seat	87	15.2	Installing the front wheel 🛠️.....	116
13.7	Checking for chain dirt	88	15.3	Removing the rear wheel 🛠️.....	117
13.8	Cleaning the chain	88	15.4	Installing the rear wheel 🛠️.....	118
13.9	Checking the chain tension	89	15.5	Checking the rear hub damping rubber pieces 🛠️.....	120
13.10	Adjusting the chain tension.....	89	15.6	Checking the tire condition	121
13.11	Checking the chain, rear sprocket, engine sprocket, and chain guide	90	15.7	Checking tire pressure	122
13.12	Removing the left side cover	92	15.8	Checking spoke tension	122
13.13	Installing the left side cover	93	15.9	Tubeless tire system.....	123
13.14	Removing the right side cover	93	15.10	Using tire repair spray	123
13.15	Installing the right side cover.....	94	16	ELECTRICAL SYSTEM	125
13.16	Removing the battery cover.....	94	16.1	Daytime running light (DRL).....	125
13.17	Installing the battery cover.....	95	16.2	Removing the 12-V battery 🛠️.....	125
13.18	Removing left fuel tank spoiler.....	95	16.3	Installing the 12-V battery 🛠️.....	127
13.19	Installing the left fuel tank spoiler	96	16.4	Charging the 12-V battery 🛠️.....	128
13.20	Removing right fuel tank spoiler	97	16.5	Changing the main fuse	130
13.21	Installing the right fuel tank spoiler ...	98	16.6	Changing the ABS fuses	131
13.22	Removing the front fender	99	16.7	Changing the fuses of individual electrical power consumers	132
13.23	Installing the front fender	99	16.8	Checking the headlight setting	133
13.24	Removing fork protector.....	100	16.9	Adjusting the headlight range.....	134
13.25	Installing the fork protector.....	100	16.10	Diagnostics connector	135
13.26	Cleaning the dust boots of the fork legs 🛠️.....	100	16.11	Front ACC1 and ACC2	135
13.27	Removing the windshield	101	16.12	ACC1 and ACC2 rear	135
13.28	Installing the windshield.....	102	17	COOLING SYSTEM	136
13.29	Removing left fuel tank cover.....	102	17.1	Cooling system	136
13.30	Installing the left fuel tank cover	103	17.2	Checking the coolant level in the compensating tank.....	136
13.31	Removing right fuel tank cover	103	17.3	Correcting the coolant level in the compensating tank.....	137
13.32	Installing the right fuel tank cover ...	104	18	TUNING THE ENGINE	139
13.33	Removing engine guard	104	18.1	Ride Mode	139
13.34	Installing the engine guard	105	18.2	Motorcycle traction control (Cornering MTC).....	139
13.35	Removing the main silencer 🛠️.....	106	18.3	Slip adjustment (optional).....	140
13.36	Installing the main silencer 🛠️.....	106	18.4	Throttle Response (optional)	140
14	BRAKE SYSTEM	108	19	SERVICE WORK ON THE ENGINE	141
14.1	Anti-lock braking system (ABS)	108	19.1	Checking the engine oil level.....	141
14.2	Checking brake discs.....	109			

19.2	Changing the engine oil and oil filter, cleaning the oil screens	141
19.3	Adding engine oil	143
19.4	Checking the free travel of the clutch lever	144
19.5	Setting the free travel of the clutch lever	144
20	CLEANING, CARE	145
20.1	Cleaning the motorcycle	145
20.2	Checks and maintenance steps for winter operation	146
21	STORAGE	147
21.1	Storage	147
21.2	Preparing for use after storage	147
22	TROUBLESHOOTING	148
23	TECHNICAL DATA	150
23.1	Engine	150
23.2	Engine tightening torques	151
23.3	Capacities	153
23.3.1	Engine oil	153
23.3.2	Coolant	153
23.3.3	Fuel	154
23.4	Chassis	154
23.5	Electrical system	155
23.6	Tires	155
23.7	Fork	155
23.8	Shock absorber	156
23.9	Chassis tightening torques	157
24	DECLARATIONS OF CONFORMITY	162
24.1	Declarations of conformity	162
24.2	Country-specific declarations of conformity	162
25	SUBSTANCES	163
26	AUXILIARY SUBSTANCES	165
27	STANDARDS	166
28	INDEX OF SPECIAL TERMS	167
29	LIST OF ABBREVIATIONS	168
30	LIST OF SYMBOLS	169
30.1	Red symbols	169
30.2	Yellow and orange symbols	169
30.3	Green and blue symbols	169
	INDEX	170

1 MEANS OF REPRESENTATION

1.1 Symbols used

The meaning of specific symbols is described below.



Indicates an expected reaction (e.g. of a work step or a function).



Indicates an unexpected reaction (e.g. of a work step or a function).



Indicates work that requires expert knowledge and technical understanding. In the interest of your own safety, have these jobs performed by an authorized KTM workshop! Your motorcycle will be cared for there to the highest degree by specially trained experts using the special tools required.



Indicates a page reference (more information is provided on the specified page).



Indicates information with more details or tips.



Indicates the result of a testing step.



Indicates a voltage measurement.



Indicates a current measurement.



Indicates the end of an activity, including potential rework.

1.2 Formats used

The typographical formats used in this document are explained below.

Proprietary name

Indicates a proprietary name.

Name[®]

Indicates a protected name.

Brand[™]

Indicates a brand available on the open market.

Underlined terms

Refer to technical details of the vehicle or indicate technical terms, which are explained in the glossary.

2.1 Use definition – intended use

The vehicle is designed and constructed to withstand the usual demands of regular traffic and use on gentle terrain (unpaved roads). This vehicle is not suitable for use on race tracks.



Info

This vehicle is only authorized for operation on public roads in its homologated version.

2.2 Misuse

The vehicle must only be used as intended.

Dangers can arise for people, property and the environment through use not as intended.

Any use of the vehicle beyond the intended and defined use constitutes misuse.

Misuse also includes the use of operating and auxiliary fluids which do not meet the required specification for the respective use.

2.3 Safety advice

A number of safety instructions need to be followed to operate the product described safely. Therefore read this instruction and all further instructions included carefully. The safety instructions are highlighted in the text and are referred to at the relevant passages.



Info

Various information and warning labels are attached in prominent locations on the product described. Do not remove any information or warning labels. If they are missing, you or others may not recognize dangers and may therefore be injured.

2.4 Degrees of risk and symbols



Danger

Identifies a danger that will immediately and invariably lead to fatal or serious permanent injury if the appropriate measures are not taken.



Warning

Identifies a danger that is likely to lead to fatal or serious injury if the appropriate measures are not taken.



Caution

Identifies a danger that may lead to minor injuries if the appropriate measures are not taken.

Note

Identifies a danger that will lead to considerable machine and material damage if the appropriate measures are not taken.



Note

Indicates a danger that will lead to environmental damage if the appropriate measures are not taken.

2.5 Tampering warning

Tampering with the noise control system is prohibited. Federal law prohibits the following acts or the causing thereof:

- 1 The removal or rendering inoperative by any person other than for purposes of servicing, repair, or replacement, of any device or element of design incorporated into any new vehicle for the purpose of noise control prior to its sale or delivery to the ultimate purchaser or while it is in use, or
- 2 the use of the vehicle after such device or element of design has been removed or rendered inoperative by any person.

Among those acts presumed to constitute tampering are the acts listed below:

- 1 Removal or puncturing of the main silencers, baffles, header pipes or any other components which conduct exhaust gases.
- 2 Removal or puncturing of parts of the intake system.
- 3 Lack of proper maintenance.
- 4 Replacing moving parts of the vehicle, or parts of the exhaust system or intake system, with parts other than those specified by the manufacturer.

2.6 Safe operation



Danger

Danger of accidents A rider who is not fit to ride poses a danger to him or herself and others.

- Do not operate the vehicle if you are not fit to ride due to alcohol, drugs or medication.
- Do not operate the vehicle if you are physically or mentally impaired.



Danger

Danger of poisoning Exhaust gases are toxic and inhaling them may result in unconsciousness and death.

- Always make sure there is sufficient ventilation when running the engine.
- Use effective exhaust extraction when starting or running the engine in an enclosed space.



Warning

Danger of burns Some vehicle components become very hot when the vehicle is operated.

- Do not touch any parts such as the exhaust system, radiator, engine, shock absorber, or brake system before the vehicle parts have cooled down.
- Let the vehicle parts cool down before you perform any work on the vehicle.

Only operate the vehicle when it is in perfect technical condition, in accordance with its intended use, and in a safe and environmentally compatible manner.

The vehicle should only be used by trained persons. An appropriate driver's license is needed to ride the vehicle on public roads.

Have malfunctions that impair safety promptly eliminated by an authorized KTM workshop.

Adhere to the information and warning labels on the vehicle.

2.7 Protective clothing



Warning

Risk of injury Missing or poor protective clothing presents an increased safety risk.

- Wear appropriate protective clothing such as helmet, boots, gloves as well as trousers and a jacket with protectors on all rides.
- Always wear protective clothing that is in good condition and meets the legal regulations.

In the interest of your own safety, KTM recommends that you only operate the vehicle while wearing protective clothing.

2.8 Work rules

Unless specified otherwise, the ignition must be turned off during all work (models with ignition lock, models with remote key) or the engine must be at a standstill (models without ignition lock or remote key).

Special tools are necessary for certain tasks. The tools are not a component of the vehicle, but can be ordered using the number in parentheses. Example: bearing puller (15112017000)

Unless otherwise noted, normal conditions apply to all tasks and descriptions.

Ambient temperature	20 °C (68 °F)
Ambient air pressure	1,013 mbar (14.69 psi)
Relative air humidity	60 ± 5 %

During assembly, use new parts to replace parts which cannot be reused (e.g. self-locking screws and nuts, expansion screws, seals, sealing rings, O-rings, pins, and lock washers).

In the case of certain screws, a screw adhesive (e.g. **Loctite**®) is required. Observe the manufacturer's instructions.

If thread locker (e.g., **Precote**®) has already been applied to a new part, do not apply any additional thread locker. After disassembly, clean the parts that are to be reused and check them for damage and wear. Change damaged or worn parts.

After completing a repair or service work, check the operating safety of the vehicle.

2.9 Environment

If you use your motorcycle responsibly, you can ensure that problems and conflicts do not occur. To protect the future of the motorcycle sport, make sure that you use your motorcycle legally, display environmental consciousness, and respect the rights of others.

When disposing of used oil, other operating and auxiliary fluids, and used components, comply with the laws and regulations of the respective country.

Because motorcycles are not subject to the EU regulations governing the disposal of used vehicles, there are no legal regulations that pertain to the disposal of an end-of-life motorcycle. Your authorized KTM dealer will be glad to advise you.

2.10 Owner's Manual

Read this owner's manual carefully and completely before making your first trip. The Owner's Manual contains useful information and many tips on how to operate, handle, and service your motorcycle. This is the only way to find out how best to customize the vehicle for your own use and how you can protect yourself from injury.



Tip

Store the Owner's Manual on your terminal device, for example, so that you can read it whenever you need to.

If you would like to know more about the vehicle or have questions on the material you read, please contact an authorized KTM dealer.

2 SAFETY ADVICE

The Owner's Manual is an important component of the vehicle. If the vehicle is sold, the Owner's Manual must be downloaded again by the new owner.

The Owner's Manual can be downloaded several times using the QR code or the link on the delivery certificate.

The Owner's Manual is also available for download from your authorized KTM dealer and on the KTM website. A printed copy can also be ordered from your authorized KTM dealer.

International KTM Website: KTM.COM

3.1 Manufacturer warranty, implied warranty

The work prescribed in the service schedule must only be carried out in an authorized KTM workshop and confirmed in the **KTM Dealer.net**, as otherwise all warranty claims will be void. Damage or secondary damage caused by tampering with and/or conversions on the vehicle are not covered by the manufacturer warranty.

3.2 Fuel, auxiliary substances



Note

Environmental hazard Improper handling of fuel is a danger to the environment.

- Do not allow fuel to enter the groundwater, the soil, or the sewage system.

Use fuels and auxiliary substances in accordance with the Owner's Manual and specification.

3.3 Spare parts, technical accessories

For your own safety, only use spare parts and accessory products that are approved and/or recommended by KTM and have them installed by an authorized KTM workshop. KTM accepts no liability for other products and any resulting damage or loss.

Certain spare parts and accessory products are specified in parentheses in the descriptions. Your authorized KTM dealer will be glad to advise you.

The latest news **KTM PowerParts** on your vehicle can be found on the KTM website.

International KTM Website: KTM.COM

3.4 Service

A prerequisite for perfect operation and prevention of premature wear is that the service, care, and tuning work on the engine and chassis is properly carried out as described in the Owner's Manual. An incorrect suspension setting can lead to damage and breakage of chassis components.

Use of the vehicle under difficult conditions, such in rain, high heat or with a heavy payload, can lead to considerably more rapid wear of components such as the drive train, brake system, or suspension components. For this reason, it may be necessary to inspect or replace parts before the next scheduled service.

It is imperative that you adhere to the stipulated run-in times and service intervals. If you observe these exactly, you will ensure a much longer service life for your motorcycle.

3.5 Figures

The figures contained in the manual may depict special equipment.

In the interest of clarity, some components may be shown disassembled or may not be shown at all. It is not always necessary to disassemble the component to perform the activity in question. Please follow the instructions in the text.

3.6 Customer service

Your authorized KTM dealer will be happy to answer any questions you may have on your vehicle and KTM.

A list of authorized KTM dealers can be found on the KTM website.

International KTM Website: KTM.COM

4.1 View of vehicle, front left (example)



F03283-10

- ❶ Socket for electrical accessories (📖 p. 21)
- ❷ Clutch lever (📖 p. 16)
- ❸ Seat lock (📖 p. 25)
- ❹ Storage compartment on the left
- ❺ Passenger foot pegs (📖 p. 26)
- ❻ Side stand (📖 p. 27)
- ❼ Rider footrests
- ❽ Shift lever (📖 p. 26)

4.2 View of vehicle, rear right (example)



F03284-10

- ① Storage compartment on the right
- ② Light switch (📖 p. 17)
- ② Menu buttons (📖 p. 18)
- ② Turn signal switch (📖 p. 19)
- ② Horn button (📖 p. 19)
- ③ Fuel tank filler cap
- ④ Start button/emergency OFF switch (📖 p. 19)
- ⑤ Hand brake lever (📖 p. 16)
- ⑥ Engine oil level viewer
- ⑦ Foot brake lever (📖 p. 26)

5.1 Vehicle identification number

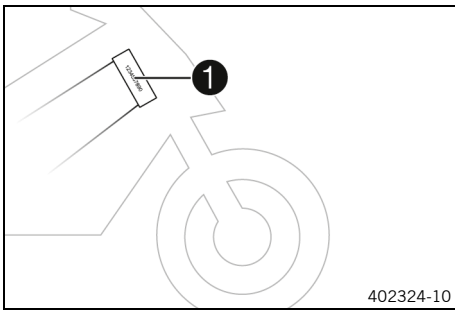

The vehicle identification number **1** is stamped on the right side of the steering head.

5.2 Type label

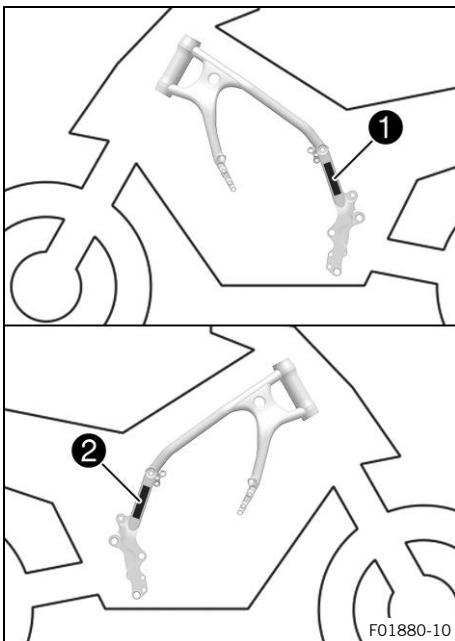

The type label **1** is located on the frame on the left.
The type label for Australia **2** is located on the frame on the right.

5.3 Key number

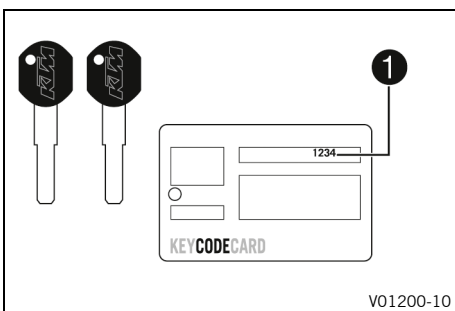

The key number **1** can be found on the **KEYCODECARD**.

i Info

You need the key number to order a spare key. Keep the **KEYCODECARD** in a safe place.

5.4 Engine number

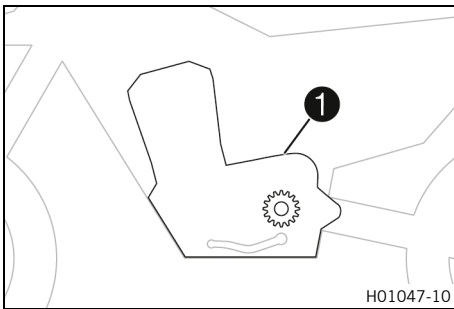

The engine number **1** is stamped onto the engine case at the top.

5.5 Fork part number

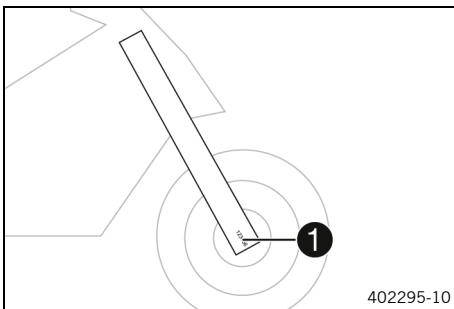

The fork part number **1** is stamped on the inner side of the fork stub.

5.6 Shock absorber article number

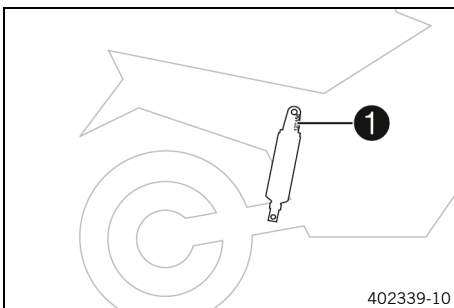

Shock absorber article number **1** is attached the top of the shock absorber.

5.7 Steering damper article number

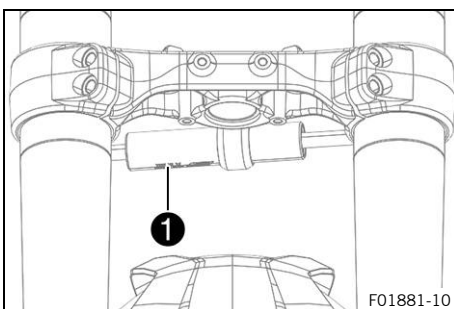

Steering damper article number **1** is embossed on the underside of the steering damper.

6.1 Clutch lever

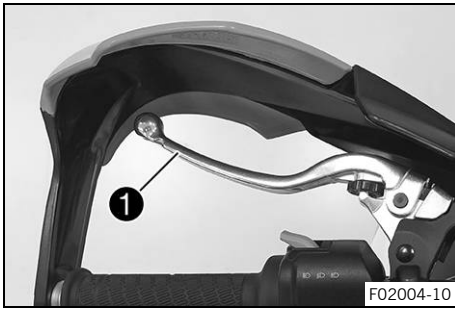

Clutch lever **1** is fitted on the handlebar on the left.

6.2 Hand brake lever

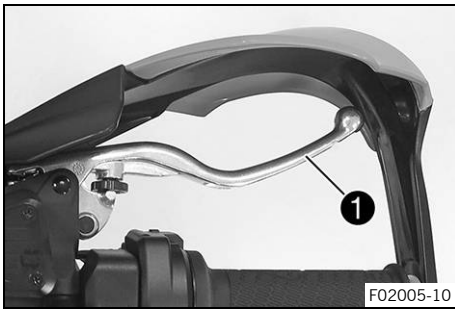

The hand brake lever **1** is fitted on the right side of the handlebar.
The front brake is engaged using the hand brake lever.

6.3 Throttle grip

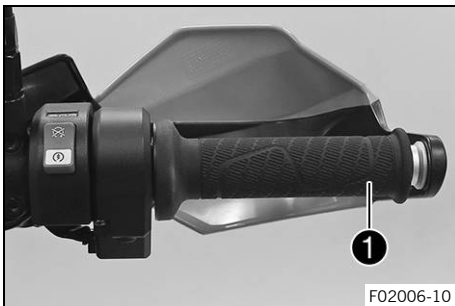

The throttle grip **1** is fitted on the right side of the handlebar.

6.4 Switches on the left side of the handlebar

6.4.1 Combination switch

The combination switch is fitted on the left side of the handlebar.

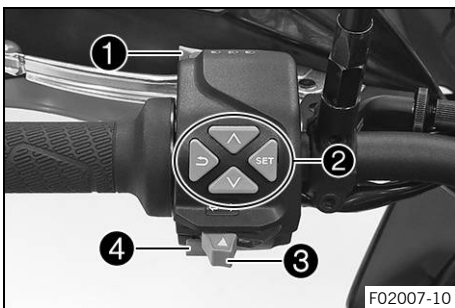

Overview of the left combination switch

- 1** Light switch (📖 p. 17)
- 2** Menu buttons (📖 p. 18)
- 3** Turn signal switch (📖 p. 19)
- 4** Horn button (📖 p. 19)

6.4.2 Light switch

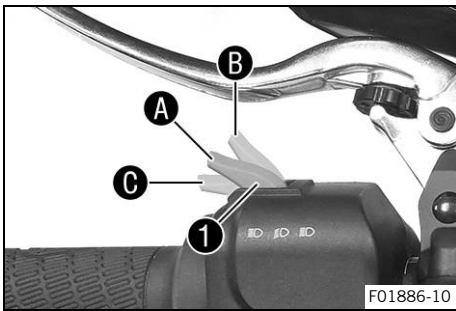

The light switch ① is fitted on the combination switch on the left.

Possible states

	Low beam on – Light switch in position A . In this position, the low beam and the tail light are switched on.
	High beam on – Push the light switch to position B . In this position, the high beam and the tail light are switched on.
	Headlight flasher – Push the light switch into position C .

6.4.3 Cruise control system tip switch

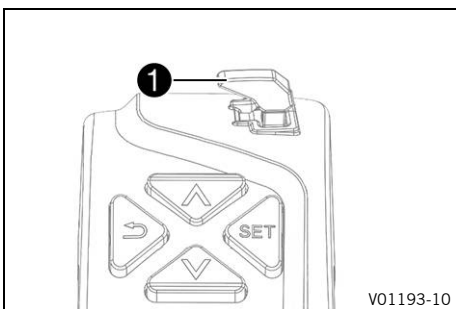

The cruise control system tip switch ① is fitted on the left side of the combination switch.

i Info

The cruise control system function (optional) must be activated to be able to use the cruise control system tip switch.

Possible states

- Cruise control system tip switch in the basic position.
- Cruise control system tip switch pressed to the left. – In this position, the cruise control system function is switched on and off. The operating mode is displayed in the combination instrument.
- Briefly press cruise control system tip switch at the top. – The last saved speed is reached and maintained. Every subsequent brief pressing increases the target speed by 1 km/h or 1 mph.
- Press and hold cruise control system tip switch at the top. – The target speed increases in increments of 5 km/h or 5 mph.
- Briefly press cruise control system tip switch at the bottom. – The cruise control system function is activated and the current speed is maintained. Every subsequent brief press reduces the target speed by 1 km/h or 1 mph.
- Press and hold cruise control system tip switch at the bottom. – The target speed decreases in increments of 5 km/h or 5 mph.

i Info

After activation of the cruise control system function, the throttle grip can be turned back to the basic position. The selected speed will be maintained. If the target speed is exceeded for less than 30 seconds by turning the throttle grip, the cruise control system remains activated.

To switch off the cruise control system function, press the cruise control system tip switch to the left.

In addition, the cruise control system function is deactivated when one of the following events occurs:

- Operating the hand brake lever
- Operating the foot brake lever
- Operating the clutch lever
- Turning the throttle grip beyond the basic position
- Control of the motorcycle traction control (**MTC**)
- Slip at the rear wheel or lifting front wheel
- A malfunction occurring, which impairs the cruise control system function
- Exceeding the target speed for more than 30 seconds when overtaking



Warning

Danger of accidents The cruise control system function is not suitable for all riding situations.

The selected target speed will not be reached, if the engine power is not sufficient for a gradient.

The selected target speed will be exceeded if the engine braking effect is not sufficient on an incline.

- Do not use the cruise control systems function on winding roads.
- Do not use the cruise control systems on slippery road surfaces (e.g. rain, ice or snow), where there is poor visibility or on unpaved surfaces (e.g. sand, stones or gravel).
- Do not use the cruise control systems function if the traffic does not permit a constant speed.

The cruise control system function is only available when motorcycle traction control (**MTC**) is activated.

When motorcycle traction control (**MTC**) is switched off, the cruise control system function is also switched off.

The cruise control system function cannot be activated during rapid acceleration.

The cruise control system function can only be activated in 2nd, 3rd, 4th, 5th and 6th gear.

The control range is from 30 to 160 km/h or from 18 to 98 mph.

6.4.4 Menu buttons

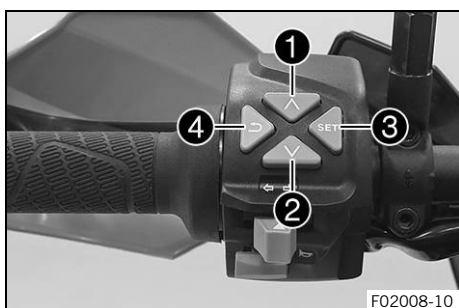

The menu buttons are fitted in the middle of the left combination switch.

The menu buttons are used to control the display on the combination instrument.

Button **1** is the **UP** button.

Button **2** is the **DOWN** button.

Button **3** is the **SET** button.

Button **4** is the **BACK** button.

6.4.5 Turn signal switch



Turn signal switch ① is fitted on the combination switch on the left.

Possible states

	Turn signal off
	Left turn signal, on – Turn signal switch pressed to the left. The turn signal switch returns to the center position after activation.
	Right turn signal, on – Turn signal switch pressed to the right. The turn signal switch returns to the center position after activation.

To switch off the turn signal, press the turn signal switch towards the switch case.

6.4.6 Horn button

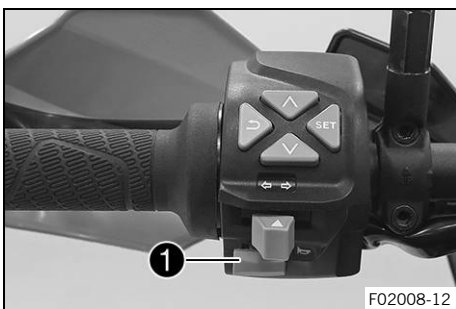

Horn button ① is fitted on the left side of the handlebar.

Possible states

- The horn button is in the basic position
- The horn button is pressed – The horn is operated in this position.

6.5 Switches on the right side of the handlebar

6.5.1 Start button/emergency OFF switch



The start button/emergency OFF switch ① is fitted on the right side of the combination switch.

Possible states

	Start button/emergency OFF switch off (upper position) – In this position, the ignition circuit is interrupted, a running engine stops, and a non-running engine cannot be started. A message appears on the display.
	Start button/emergency OFF switch on (middle position) – This position is required for operation; the ignition circuit is closed.
	Starter motor on (lower position) – In this position, the starter motor is actuated.

6.6 Ignition and steering lock



The ignition and steering lock is located in front of the upper triple clamp.

Possible states

	Ignition off – In this position, the ignition circuit is interrupted, a running engine stops, and a non-running engine will not start. The ignition key can be removed.
	Ignition on – In this position, the ignition circuit is closed and the engine can be started.
	Steering locked – In this position, the ignition circuit is interrupted and the steering locked. The ignition key can be removed.

6.7 Locking the steering

Note

Danger of damage The parked vehicle can roll away or fall over.

- Park the vehicle on a firm and level surface.

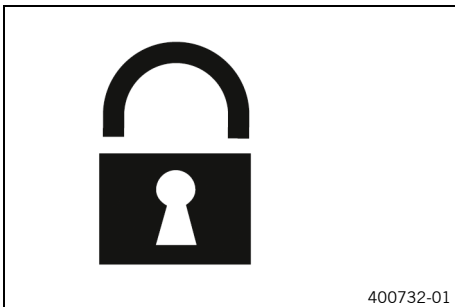

- Park the vehicle.
- Turn the handlebar all the way to the left.
- Insert the ignition key into the ignition and steering lock, press in, and turn to the left. Remove the ignition key.
- ✓ Steering is no longer possible.

6.8 Unlocking the steering

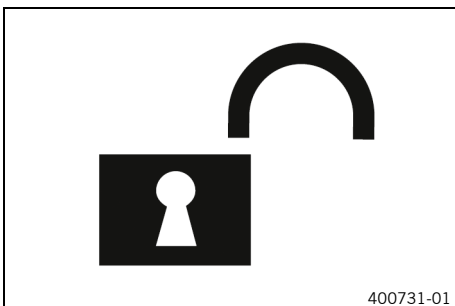

- Insert the ignition key into the ignition and steering lock, press in, and turn to the right. Remove the ignition key.
- ✓ The handlebar can now be moved again.

6.9 Socket for electrical accessories

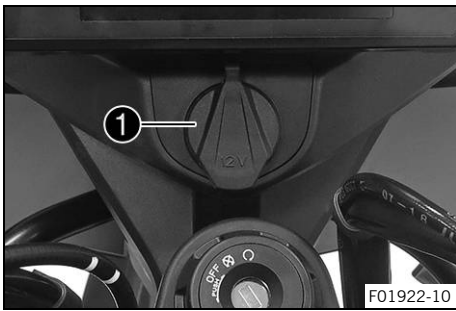

Socket ① for electrical accessories is fitted in front of the upper triple clamp. It is connected to the ignition plus and is fuse-protected.

Socket for electrical accessories	
Voltage	12 V
Maximum current consumption	10 A

6.10 Opening the fuel tank filler cap



Danger

Fire hazard Fuel is highly flammable.

The fuel in the fuel tank expands when warm and can escape if overfilled.

- Do not fuel the vehicle in the vicinity of open flames or lit cigarettes.
- Switch off the engine for refueling.
- Make sure that no fuel is spilled; particularly not on hot parts of the vehicle.
- If any fuel is spilled, wipe it off immediately.
- Observe the specifications for refueling.



Warning

Danger of poisoning Fuel is poisonous and a health hazard.

- Avoid skin, eye and clothing contact with fuel.
- Immediately consult a doctor if you swallow fuel.
- Do not inhale fuel vapors.
- In case of skin contact, rinse the affected area with plenty of water.
- Rinse the eyes thoroughly with water, and consult a doctor in case of fuel contact with the eyes.
- Change your clothing in case of fuel spills on them.
- Keep fuels correctly in a suitable canister, and out of the reach of children.



Note

Environmental hazard Improper handling of fuel is a danger to the environment.

- Do not allow fuel to enter the groundwater, the soil, or the sewage system.

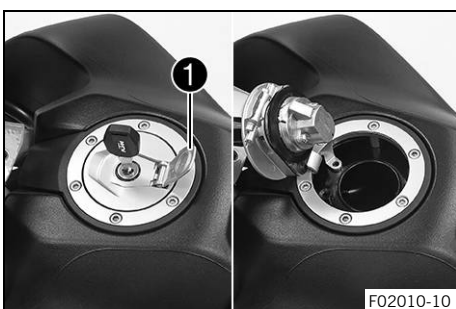

- Lift cover ① of the fuel tank filler cap and insert the ignition key into the lock.

Note

Danger of damage The ignition key may break if overloaded. Damaged ignition keys must be replaced.

- Push down on the fuel tank filler cap to take pressure off the ignition key.
- Turn the ignition key 90° clockwise.
- Lift the fuel tank filler cap.

6.11 Closing the fuel tank filler cap

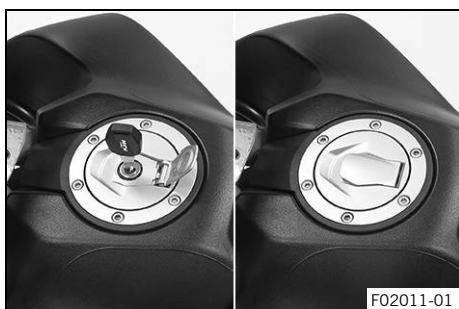

- Fold down the fuel tank filler cap.
- Turn the ignition key 90° clockwise.
- Push down the fuel tank filler cap and turn the ignition key counterclockwise until the lock closes.



Warning

Fire hazard Fuel is highly flammable, toxic and a health hazard.

- Check that the fuel tank filler cap is locked correctly after closing.
- Change your clothing if fuel spills on them.
- Rinse the affected area immediately with plenty of water in the event of contact with the skin.

- Remove the ignition key and close the cover.

6.12 Fuel cocks

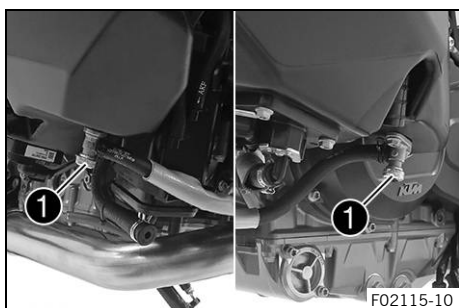

A fuel cock **1** is located on each side of the fuel tank.

i Info

The fuel cocks are located behind the fuel tank covers. The fuel cocks must always be open during operation. The fuel cocks are only closed to remove the fuel tank.

Possible states

- Fuel cocks are closed – Level equalization cannot take place and the fuel supply to the throttle valve body is shut off.
- Fuel cocks are open – Level equalization can take place and the fuel supply to the throttle valve body is open.

6.13 Opening the storage compartment on the left

Preparatory work

- Remove the seat. (📖 p. 87)
- Remove the left side cover. (📖 p. 92)

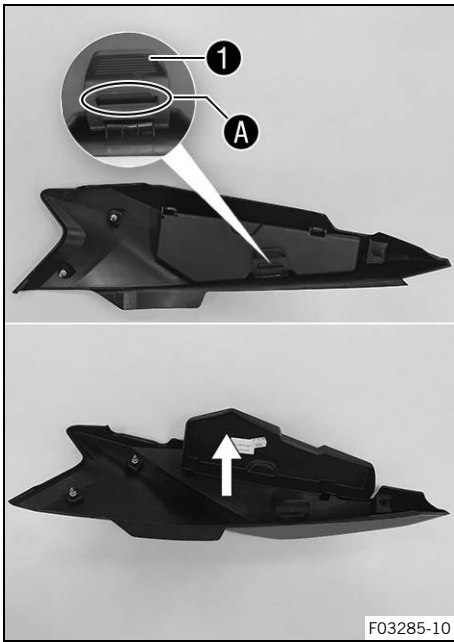

Main work

- Lift the elastic fastener ① and detach in area ②.
- Open storage compartment.



6.14 Closing the storage compartment on the left

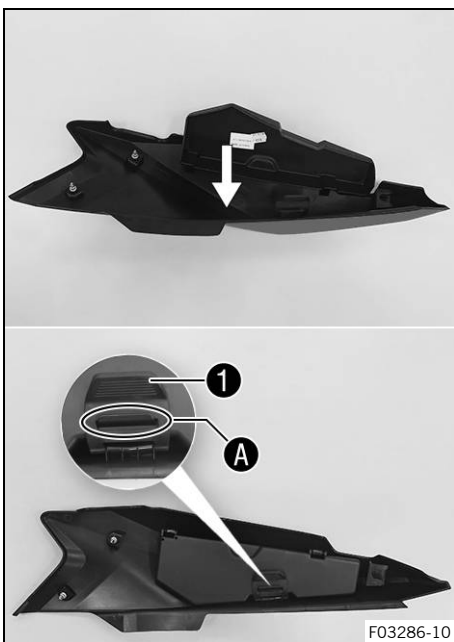

Main work

- Close the storage compartment.
- Raise elastic fastener ① and hang up in area ②.

Finishing work

- Install the left side cover. (📖 p. 93)
- Mount the seat. (📖 p. 87)



6.15 Opening the storage compartment on the right

Preparatory work

- Remove the seat. (📖 p. 87)
- Remove the right side cover. (📖 p. 93)

Main work

- Lift the elastic fastener **1** and detach in area **A**.
- Open storage compartment.

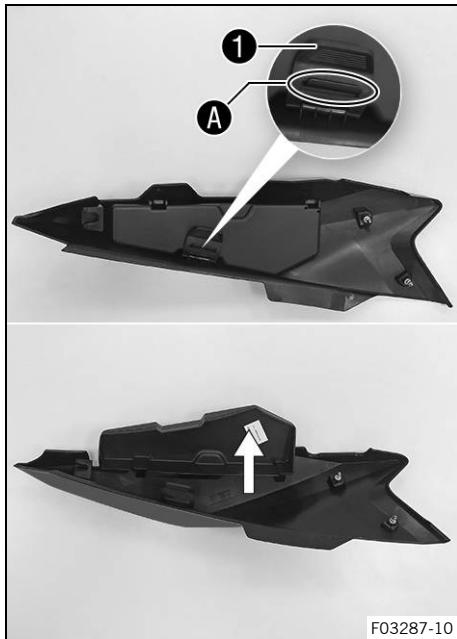

6.16 Closing the storage compartment on the right

Main work

- Close the storage compartment.
- Raise elastic fastener **1** and hang up in area **A**.

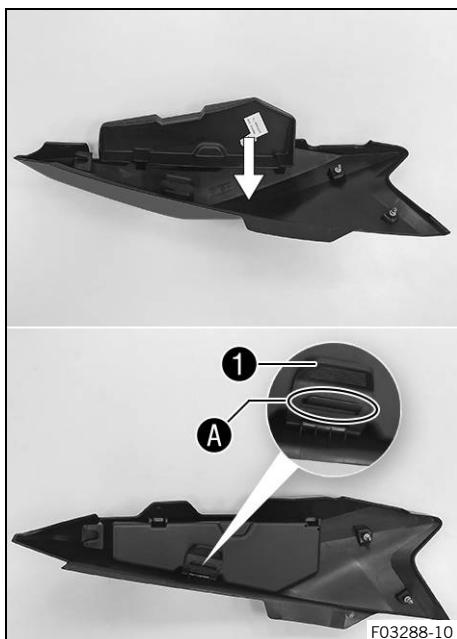

Finishing work

- Install the right side cover. (📖 p. 94)
- Mount the seat. (📖 p. 87)

6.17 Tool set

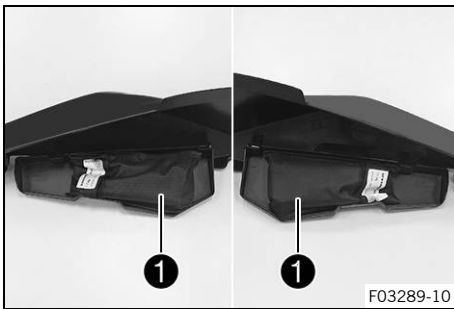

The left or right storage compartment contains the on-board tool set ①.

6.18 Grab handles



The grab handles ① are used for moving the motorcycle around. If you carry a passenger, the passenger can hold onto the grab handles during the trip.

6.19 Luggage rack plate



The luggage rack plate ① is located behind the seat. The base plate of a luggage system can be mounted on the luggage rack plate (optional). The luggage rack plate may not be loaded with more than the specified weight.

Maximum permissible load on luggage rack plate	5 kg (11 lb.)
--	---------------

i Info
Follow the instructions provided by the luggage manufacturer.

6.20 Seat lock

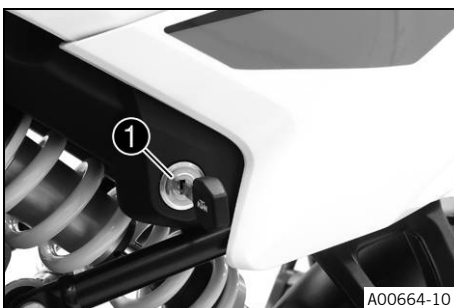

Seat lock ① is located on the left side of the vehicle. It can be unlocked using the ignition key.

6.21 Passenger foot pegs

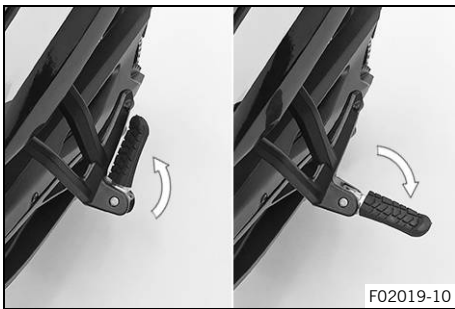

The passenger foot pegs can be folded up and down.

Possible states

- Passenger foot pegs folded up – For operation without a passenger.
- Passenger foot pegs folded down – For operation with a passenger.

6.22 Shift lever

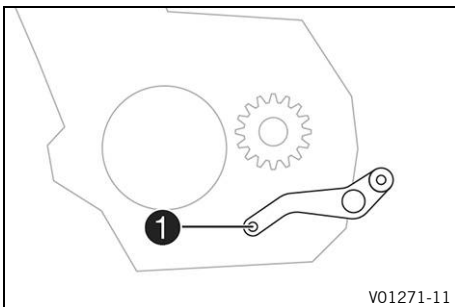

Shift lever **1** is mounted on the left of the engine.

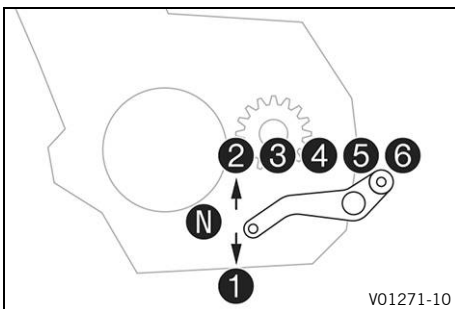

The gear positions can be seen in the figure.

The neutral or idle position is between the first and second gears.

6.23 Foot brake lever

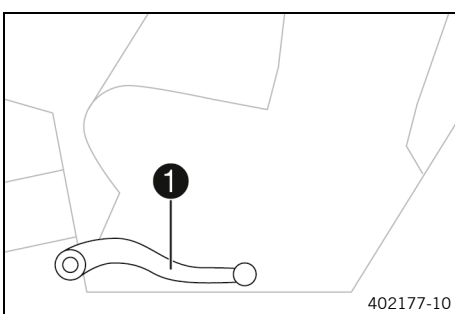

Foot brake lever **1** is located in front of the right footrest. The rear brake is activated using the foot brake lever.

6.24 Side stand

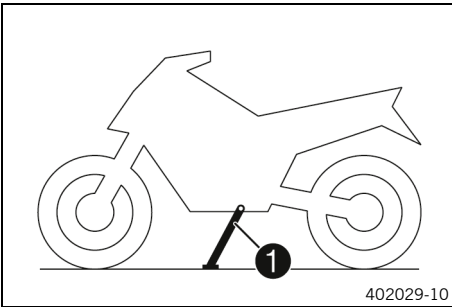

The side stand **1** is located on the left of the vehicle.
The side stand is used for parking the motorcycle.



Info

The side stand must be folded up during motorcycle use.
The side stand is coupled with the safety starting system;
follow the riding instructions.

Possible states

- Side stand folded out – The vehicle can be supported on the side stand. The safety starting system is active.
- Side stand folded in – This position is mandatory when riding the motorcycle. The safety starting system is inactive.

7.1 Combination instrument

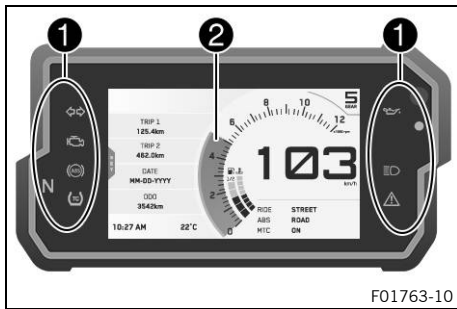

The combination instrument is attached in front of the handlebar. The combination instrument is divided into two function areas.

① indicator lamps (📖 p. 30)

Display ②

7.2 Activation and test



Activation

The combination instrument is activated when the ignition is switched on.







i Info

The brightness of the displays is controlled by an ambient light sensor in the combination instrument.

Test

The welcome text appears on the display and all indicator lamps are briefly activated for a function check.

i Info

The malfunction indicator lamp  always lights up as long as the engine is not running. If the engine is running and the malfunction indicator lamp  lights up, stop (taking care not to endanger yourself or other road users in the process) and contact an authorized KTM workshop. The oil pressure warning lamp  always lights up as long as the engine is not running. If the engine is running and the oil pressure warning lamp  lights up, stop immediately (taking care not to endanger yourself or other road users in the process) and switch off the engine. The ABS warning lamp  and TC indicator lamp  light up until a speed of approx. 6 km/h (approx. 4 mph) or more has been reached.

7.3 Day-night mode

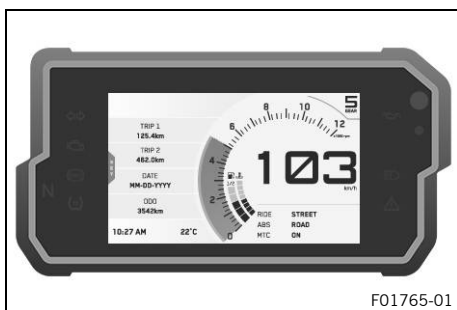

Day mode is shown in a bright color.

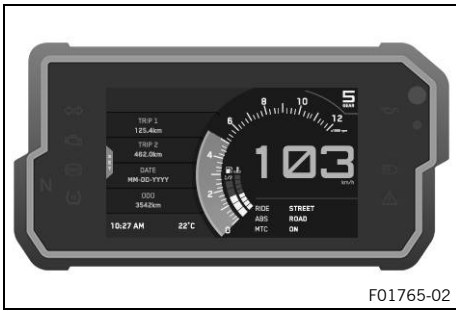

Night mode is shown in a dark color.

i Info
The ambient light sensor in the combination instrument measures the brightness of the environment. The display is brightened, darkened or switched to the other mode depending on the light intensity measured by the ambient light sensor.
The display mode can be configured in the **Display Theme** submenu. Here, you can select automatic day-night mode or permanent night mode.

7.4 Warnings

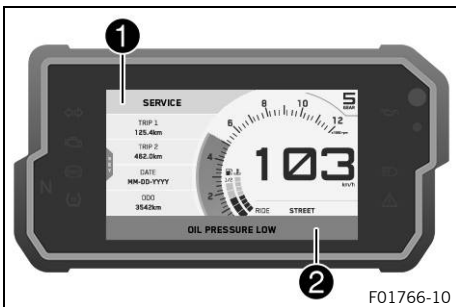

Warnings appear on the top and/or bottom edge of the display; these are marked yellow or red depending on their relevance. Yellow warnings **1** indicate a malfunction or information which requires prompt intervention or an adjustment to the riding style. Red warnings **2** indicate a malfunction or information which requires immediate intervention.

i Info
Warnings can be hidden by pressing any button. All the existing warnings are displayed in the **Warning** submenu until they are no longer active.

7.5 Ice warning

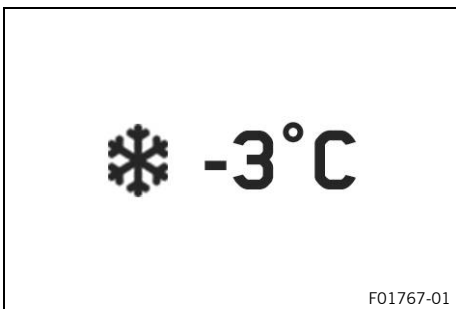

The ice warning ❄ goes on when there is an increased risk of ice on the roads.
The ice warning ❄ appears on the display when the ambient temperature drops below the specified value.

Temperature	$\leq 4 \text{ }^{\circ}\text{C}$ ($\leq 39 \text{ }^{\circ}\text{F}$)
-------------	--

The ice warning ❄ goes out on the display when the ambient temperature rises above the specified value again.

Temperature	$\geq 6 \text{ }^{\circ}\text{C}$ ($\geq 43 \text{ }^{\circ}\text{F}$)
-------------	--

i Info
When the ice warning ❄ lights up, the warning **ICE WARNING** also appears.

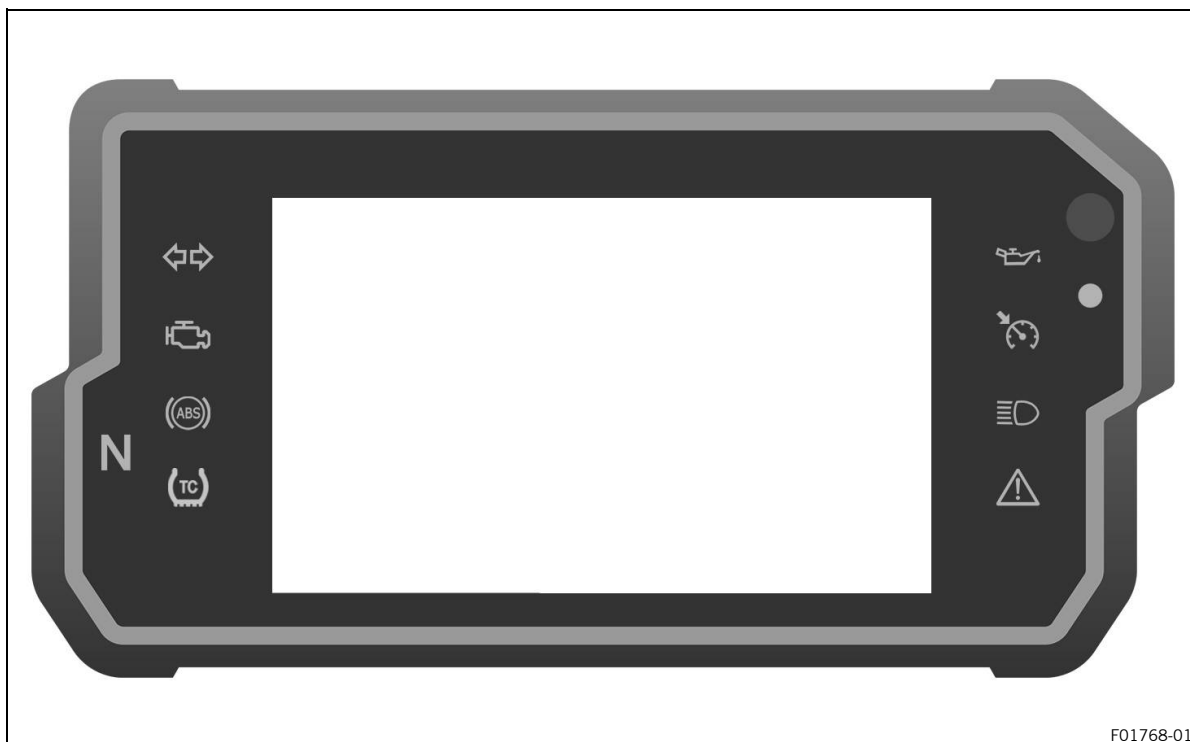

7.6 Indicator lamps







F01768-01

The indicator lamps offer additional information about the operating state of the motorcycle. When the ignition is switched on, all indicator lamps light up briefly, except for the TC indicator lamp .







Info







The malfunction indicator lamp  always lights up as long as the engine is not running. If the engine is running and the malfunction indicator lamp  lights up, stop (taking care not to endanger yourself or other road users in the process) and contact an authorized KTM workshop.

The oil pressure warning lamp  always lights up as long as the engine is not running. If the engine is running and the oil pressure warning lamp  lights up, stop immediately (taking care not to endanger yourself or other road users in the process) and switch off the engine.

The ABS warning lamp  and TC indicator lamp  light up until a speed of approx. 6 km/h (approx. 4 mph) or more has been reached.

Possible states

	The turn signal indicator lamp flashes green simultaneously with the turn signal – The turn signal is switched on.
	Malfunction indicator lamp lights up yellow – The <u>OBD</u> has detected a malfunction in the vehicle electronics. Come safely to a halt, and contact an authorized KTM workshop.
	ABS warning lamp lights up yellow – Status or error messages relating to <u>ABS</u> .
	The idle indicator lamp lights up green – The transmission is in neutral.
	TC indicator lamp lights up/flashes yellow – <u>MTC</u> ( p. 139) is not enabled or is currently intervening. The TC indicator lamp also lights up if a malfunction is detected. Contact an authorized KTM workshop. The TC indicator lamp flashes, if <u>MTC</u> or <u>MSR</u> (optional) actively engage.

	The oil pressure warning lamp lights up red – The oil pressure is too low. Stop immediately, taking care not to endanger yourself or other road users in the process, and switch off the engine.
	The alarm system indicator lamp lights up or flashes red – Status or error message of the alarm system.
	The cruise control system indicator lamp (optional) lights up yellow – The cruise control system function is switched on, but cruise control is not activated.
	The cruise control system indicator lamp (optional) lights up green – The cruise control system function is switched on and cruise control is activated.
	The high beam indicator lamp lights up blue – The high beam is switched on.
	The general warning lamp lights up yellow – A note/warning note on operating safety has been detected. This is also shown in the display.

7.7 Display

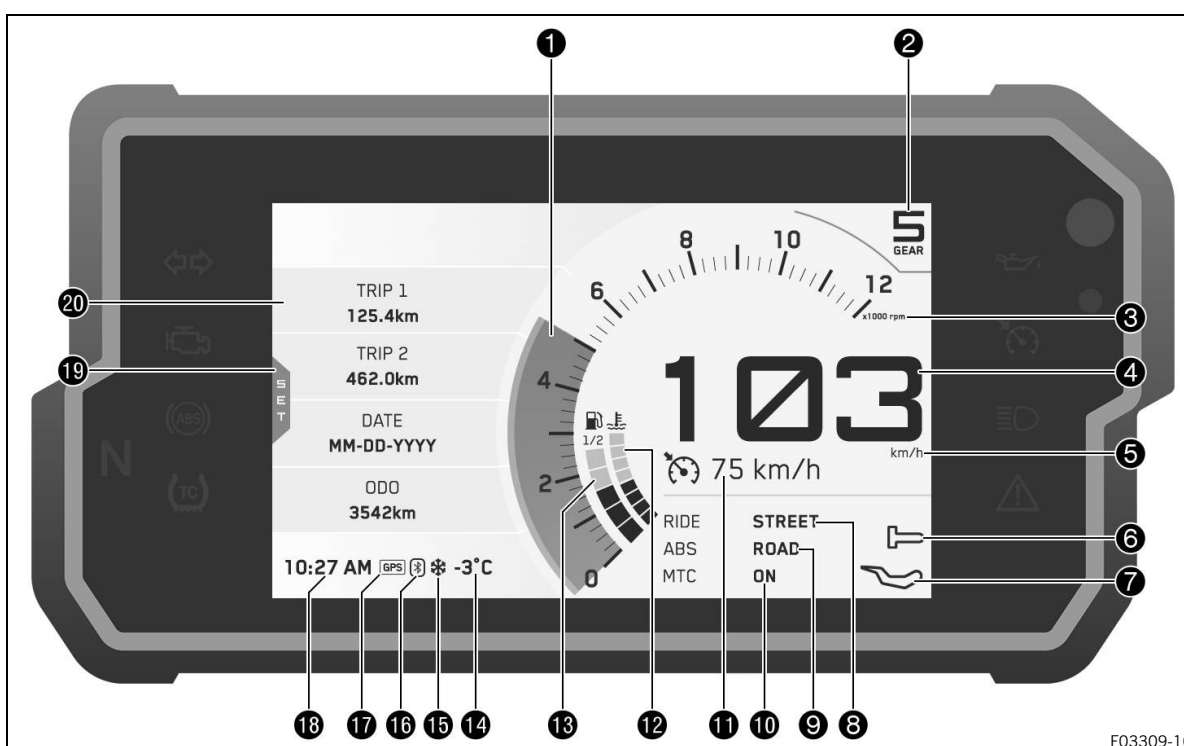

F03309-10

- ① Speed (📖 p. 33)
- ① Shift warning light (📖 p. 33)
- ① The shift warning light is integrated in the tachometer display.
- ② Gear display
- ③ Unit for the speed display
- ④ Speedometer (📖 p. 33)
- ⑤ Unit for the speedometer
- ⑥ Heated grip (optional) (📖 p. 34)
- ⑦ Seat heating (optional) (📖 p. 34)
- ⑧ Ride display (📖 p. 34)
- ⑨ ABS display (📖 p. 34)

7 COMBINATION INSTRUMENT

- 10 MTC display (📖 p. 35)
- 11 Cruise control indicator (optional) (📖 p. 35)
- 12 Coolant temperature indicator (📖 p. 35)
- 13 Fuel level display (📖 p. 36)
- 14 Ambient air temperature indicator (📖 p. 36)
- 15 Ice warning (📖 p. 29)
- 16 Bluetooth®
- 17 GPS
- 18 Time (📖 p. 36)
- SET
- 19 Only shown where the menu is closed.
- 20 Favorites display (📖 p. 37)

7.8 Rally display (optional)



F03312-10

i Info

The figure shows the start screen of the combination instrument in active riding mode **Rally** (optional). If the menu is opened, the speed is still displayed.

- 1 Drive mode **Rally** (optional)
- 2 ABS mode
- 3 **Throttle Response** (optional) (📖 p. 140)
- 4 Slip adjustment (optional) (📖 p. 140)

7.9 Speed

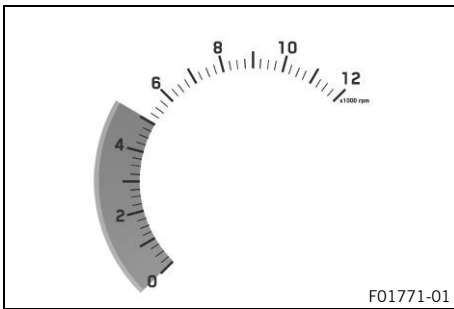

The speed is measured in revolutions per minute.

7.10 Shift warning light

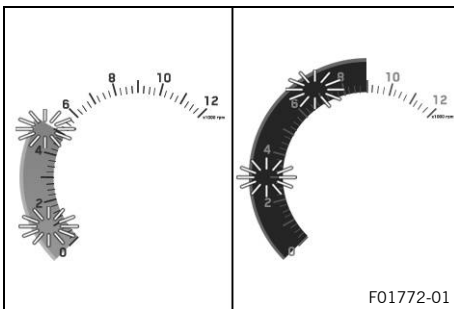

The shift warning light is integrated in the tachometer display. In the **Shift Light** submenu, the engine speed for the shift warning light can be set. The shift warning light is always active during the running-in phase (up to 1,000 km / 621 mi). The shift warning light can only be deactivated, and the values for **RPM1** and **RPM2** can only be adjusted after this. In **RPM1** the shift warning light flashes and in **RPM2** it flashes and the color changes.

i Info

In sixth-gear, the shift warning light is deactivated when the engine is warm after the first service.

Coolant temperature	≤ 35 °C (≤ 95 °F)
ODO	< 1,000 km (< 620 mi)
The shift warning light always flashes at	6,500 rpm
Coolant temperature	> 35 °C (> 95 °F)
ODO	> 1,000 km (> 620 mi)
RPM1 shift warning light	flashes
RPM2 shift warning light	flashes and changes color

7.11 Speedometer

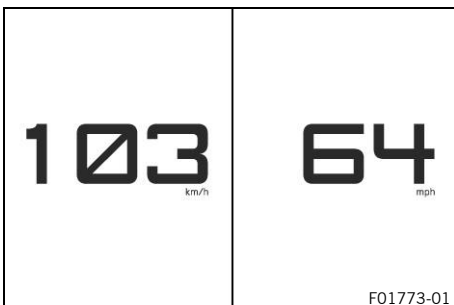

Speed is shown in kilometers per hour **km/h** or in miles per hour **mph**. The unit of speed can be configured in the **Distance** submenu.

7.12 Heated grip (optional)

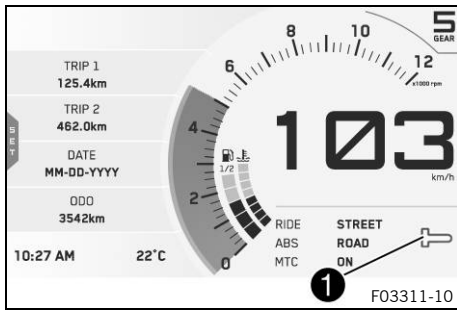

When the heated grip is switched on, the **Heating Grip** symbol appears in the ❶ area of the display. The heated grip can be configured in the **Heating Grip** submenu (optional function).

7.13 Seat heating (optional)

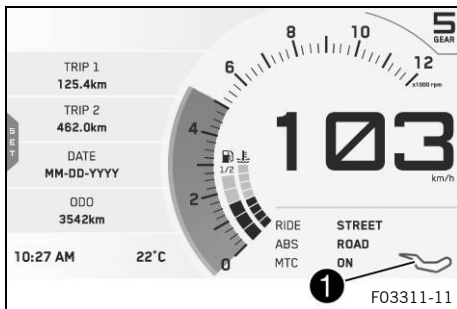

When the seat heating is switched on, the **Heating Seat** symbol appears in area ❶ of the display. The front rider's seat heating can be configured in the **Heating Seat Rider** submenu (optional function).

i Info

The heating level for the passenger seat heating can be controlled by a switch next to the right grab handle.

7.14 Ride display

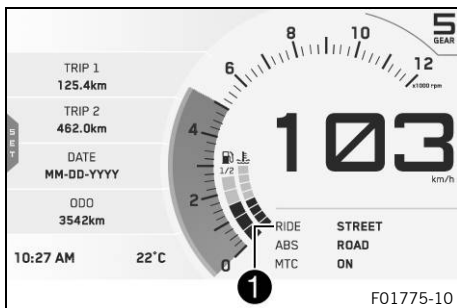

The **Ride Mode** (🏍️ p. 139) setting is shown in area ❶ of the display. The drive mode can be configured in the **Ride Mode** submenu.

7.15 ABS display

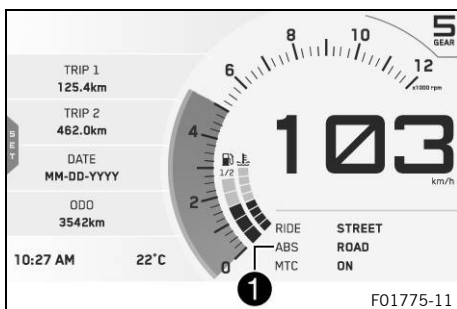

The ABS mode setting is shown in the ❶ area of the display. The ABS can be configured in the **ABS** submenu.

7.16 MTC display

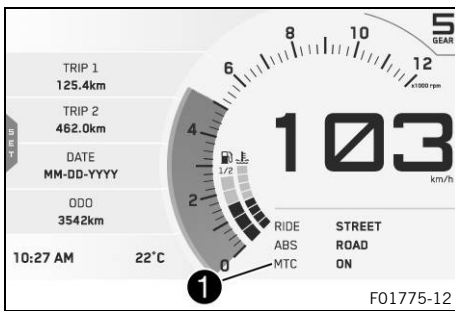

The **1** area of the display indicates whether **MTC** (📖 p. 139) is switched on or off. The motorcycle traction control can be switched on or off in the **MTC** submenu.

7.17 Cruise control indicator (optional)

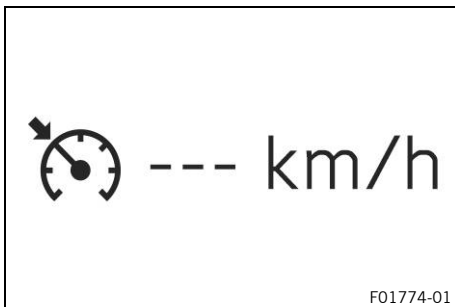

When cruise control (optional) is activated, the operating mode is displayed on the combination instrument display. Cruise control is operated using the cruise control tip switch (📖 p. 17).

i Info
If the cruise control system function is switched on but cruise control is not activated, the cruise control system indicator lamp lights up yellow. If the cruise control system function is switched on and cruise control is activated, the cruise control system indicator lamp lights up green.

7.18 Coolant temperature indicator

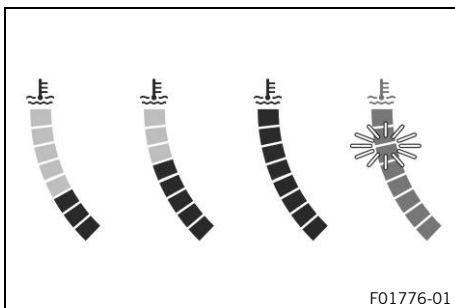

The coolant temperature indicator consists of bars. The more bars that light up, the hotter the coolant. Emergency mode operation is automatically activated at a coolant temperature of 120 °C.

Note
Engine failure Overheating damages the engine.

- If the coolant temperature warning is displayed, stop immediately and take care not to endanger yourself or other traffic participants in the process.
- Allow the engine and cooling system to cool down.
- Check and, if necessary, correct the coolant level on the cooling system while it is in a cooled state.

i Info
When all the bars flash, the warning **ENGINE TEMP HIGH** also appears. If the cooling system overheats, the maximum engine speed is limited.

Possible states

- The engine is cold – Up to three bars light up.
- Engine warm – Four bars light up.
- Engine hot – Five to eight bars light up.
- Engine very hot – All eight bars light up red.

7.19 Fuel level display

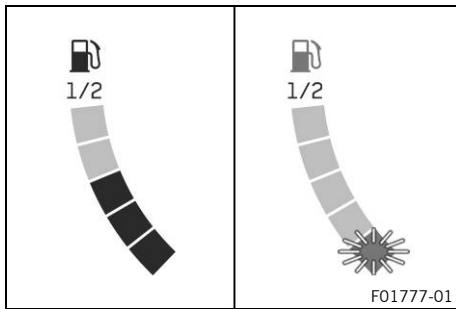

The fuel level display consists of bars. The more bars are lit, the more fuel is in the fuel tank.

i Info

Measurement of the fuel supply only becomes active after reaching half of the fuel tank content. Up to half of the fuel tank content, the fuel level display will be shown as full. If the fuel level is getting low, the last segment flashes red and the following warning **LOW FUEL** also appears. The fuel level is displayed with a slight delay to prevent the indicator from constantly moving while riding. The fuel level display is not updated while the side stand is folded out or the emergency off switch is switched off. Once the side stand is folded up and the emergency OFF switch is switched on, the fuel level display is next updated after 2 minutes. The fuel level display flashes if the combination instrument does not receive a signal from the fuel level sensor.

7.20 Ambient air temperature indicator

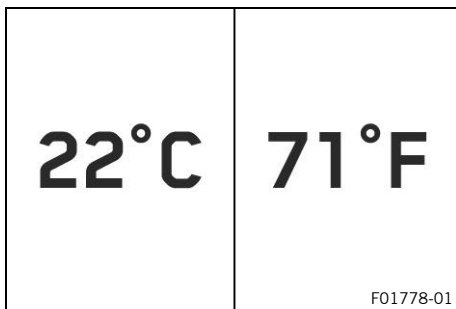

The ambient air temperature is displayed in **°C** or **°F**. The unit of the ambient air temperature can be configured in the **Temperature** submenu.

7.21 Time

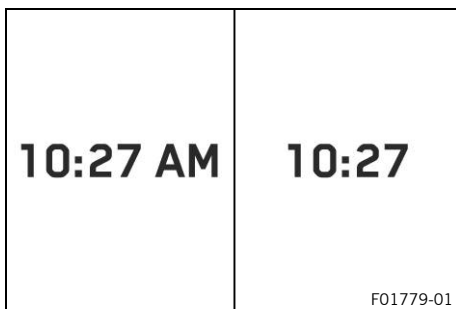

The time is displayed in 24 hour format in all languages except for EN-US. The time is displayed in 12 hour format if the language is set to EN-US. The time can be configured in the **Clock/Date** submenu.

i Info

The time must be reset if the 12-V battery was disconnected from the vehicle or the fuse was removed.

7.22 Favorites display

TRIP 1 125.4km	TRIP 1 125.4km ØCONS1 5.6l/100km
TRIP 2 462.0km	TRIP 2 462.0km ØCONS2 5.3 l/100km
DATE MM-DD-YYYY	DATE MM-DD-YYYY ODO 3542km
ODO 3542km	BATTERY 12.3V PHONE BATT
	F01780-01

Up to eight items of information are shown in the **Favorites** display. The **Favorites** display can be freely configured in the **Favorites** sub-menu.

Info
One to four items of information selected are displayed on two lines. Five to eight items of information selected are displayed on a single line.

7.23 Quick Selector 1 display

TRIP 1	
TRIP 0.0km	
ØCONS ---l/100km	
ØSPEED ---km/h	
TRIP TIME 00:00	
FUEL RANGE ---km	
	F03308-01

When the menu is closed, the **Quick Selector 1** display is opened by pressing the **UP** button. Press the **BACK** button to close the **Quick Selector 1** display.

Info
The **Quick Selector 1** display can be configured in the **Settings** menu under **Quick Selector 1**. Any information can be selected.

7.24 Quick Selector 2 display

TRIP 2	
TRIP 0.0km	
ØCONS ---l/100km	
ØSPEED ---km/h	
TRIP TIME 00:00	
FUEL RANGE ---km	
	F03310-01

When the menu is closed, the **Quick Selector 2** display is opened by pressing the **DOWN** button. Press the **BACK** button to close the **Quick Selector 2** display.

Info
The **Quick Selector 2** display can be configured in the **Settings** menu under **Quick Selector 2**. Any information can be selected.

7.25 Navigation display

<p>00:25 REROUTE</p> <p>76.2 km EXIT 2</p> <p>BERCHTESGADENER BUNDESTRASSE</p>	<p>00:25 178.3 km</p> <p>76.2 km EXIT 2</p> <p>BERCHTESGADENER BUNDESTRASSE</p>
	F01783-01

The **Navigation** display appears when the navigation function is active.

In the **Navigation** display, the direction arrow, the distance from the destination, the estimated arrival time of the cellphone, the distance to the next waypoint and the street name are displayed. The **Navigation** display can be switched on or off in the **Navigation** sub-menu.

Info
If the visual navigation is activated, the **Favorites** display is hidden.

7.26 Menu

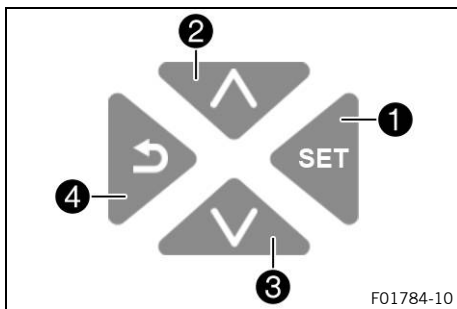

Info

Press the **SET** button ① in the start screen to open the menu.

Navigate through the menu using the **UP** button ② or the **DOWN** button ③.

By pressing the **BACK** button ④, the menu structure jumps one step back, or the menu is closed.

7.26.1 KTM MY RIDE

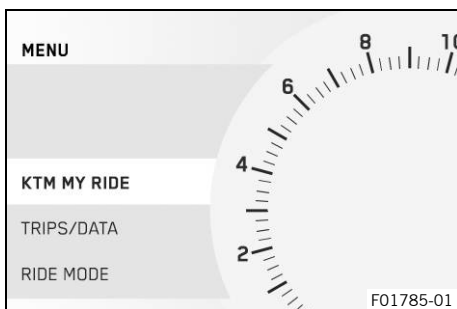

Condition

- The motorcycle is stationary.
- **Bluetooth®** function is activated.
- Press the **SET** button when the menu is closed.
- Press the **UP** or **DOWN** button until **KTM MY RIDE** is marked. Press the **SET** button to open the menu.

In the **KTM MY RIDE** menu, an appropriate cellphone or headset can be paired with the combination instrument via **Bluetooth®** and the audio function and navigation function can be configured.

Info

Not every cellphone and headset is suitable for pairing with the combination instrument.

The standard **Bluetooth®** 2.1 must be supported.

7.26.2 Audio

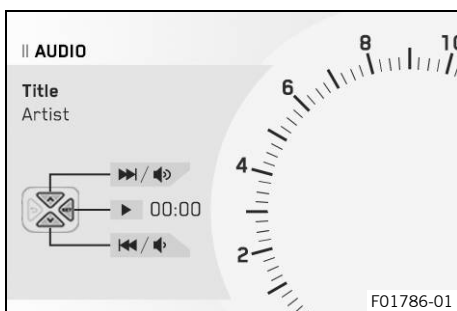

Condition

- **Bluetooth®** function is activated.
- The combination instrument is connected to a suitable cellphone.
- The combination instrument is connected to a suitable headset.
- Press the **SET** button when the menu is closed.
- Press the **UP** or **DOWN** button until **KTM MY RIDE** is marked. Press the **SET** button to open the menu.



Warning

Danger of accidents Headphone volume which is too high distracts attention from traffic activity.

- Always select headphone volume which is low enough for you to still clearly hear acoustic signals.

- Press the **UP** or **DOWN** button until **Audio** is marked. Press the **SET** button to open the submenu.
- Press and hold **UP** button to increase the audio volume.
- Press and hold **DOWN** button to reduce the audio volume.
- Press the **UP** button briefly to change to the next audio track.

- Briefly pressing the **DOWN** button twice changes to the previous audio title or plays the current audio title from the start, depending on the cellphone model.
- Press the **SET** button to play or pause the audio track.

**Info**

With some cellphones, the audio player needs to be started before playback is possible.
The audio function can be added to **Quick Selector 1** or **Quick Selector 2** for easier operation.

7.26.3 Navigation

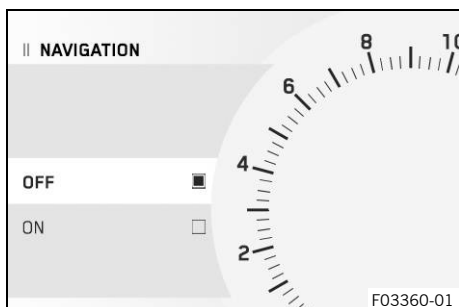
**Condition**

- **Bluetooth®** function is activated.
 - The **KTM MY RIDE Navigation** app is installed and opened on a suitable cellphone (**Android®** devices Version 6.0 and higher, iOS devices Version 10 and higher).
 - The combination instrument is connected to a suitable cellphone.
 - The GPS function is activated on the connected cellphone.
 - For voice navigation: The combination instrument is connected to a suitable headset and an appropriate language package has been downloaded in the **KTM MY RIDE Navigation** app.
- Press the **SET** button when the menu is closed.
 - Press the **UP** or **DOWN** button until **KTM MY RIDE** is marked. Press the **SET** button to open the menu.
 - Press the **UP** or **DOWN** button until **Navigation** is marked. Press the **SET** button to open the submenu.
 - Activate menu item using the **UP** or **DOWN** button.
 - Press the **SET** button to switch the visual navigation on or off.

**Info**

Voice navigation remains switched on if it has been activated.
The volume of the activated voice navigation is identical to the volume of the audio player on the cellphone. If the volume on the cellphone is changed, the volume of the activated voice navigation also changes.

7.26.4 Pairing

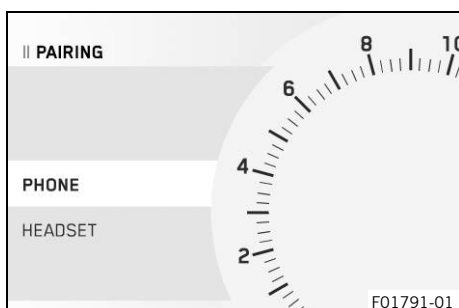
**Condition**

- The motorcycle is stationary.
 - **Bluetooth®** function is activated.
- Press the **SET** button when the menu is closed.
 - Press the **UP** or **DOWN** button until **KTM MY RIDE** is marked. Press the **SET** button to open the menu.
 - Press the **UP** or **DOWN** button until **Pairing** is marked. Press the **SET** button to open the submenu.

A suitable cellphone or headset can be paired with the combination instrument via **Bluetooth®** in the **Pairing** submenu.

i Info

The **Bluetooth®** function can only be used in conjunction with **KTM MY RIDE**.

When the **Bluetooth®** function is switched on and the device is connected, the **Bluetooth®** symbol appears in the display of the combination instrument.

Not every cellphone and headset is suitable for pairing with the combination instrument.

7.26.5 Phone

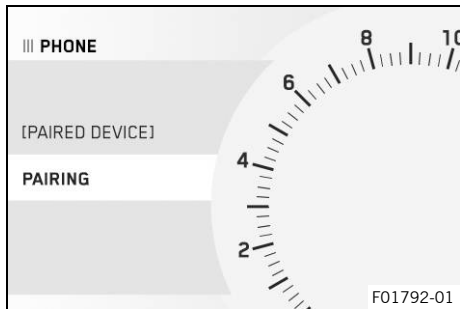

Condition

- The motorcycle is stationary.
 - **Bluetooth** function is activated.
 - The **Bluetooth®** function should also be activated in the device to be paired.
- Press the **SET** button when the menu is closed.
 - Press the **UP** or **DOWN** button until **KTM MY RIDE** is marked. Press the **SET** button to open the menu.
 - Press the **UP** or **DOWN** button until **Pairing** is marked. Press the **SET** button to open the submenu.
 - Press the **UP** or **DOWN** button until **Phone** is marked. Press the **SET** button to open the submenu.

i Info

Only one cellphone can be paired with the combination instrument.

- Press the **UP** or **DOWN** button until **Pairing** is marked. Press the **SET** button to open the submenu.
- The combination instrument starts searching for a suitable cellphone. If the search was successful, the name of the cellphone is displayed in the **Pairing** submenu. Press the **SET** button to start the pairing.

i Info

The cellphone must be visible via **Bluetooth®** for the cellphone to be found by the combination instrument.

- A message appears on the combination instrument indicating that this is now ready for pairing. The pairing is completed successfully by confirming the **Passkey** on the cellphone and on the combination instrument.

i Info

Once the pairing is completed, the name of the paired cellphone is displayed in the **Phone** submenu.

Press the **UP** or **DOWN** button until the paired device is marked. The paired device can be deleted by pressing the **SET** button.

Not every cellphone is suitable for pairing with the combination instrument.

- Move the previously paired device into the range of the combination instrument while the **Bluetooth®** function is active.

- ✓ The device is automatically paired with the combination instrument.
- ✗ If the device is not automatically paired with the combination instrument after approx. 30 seconds:
 - Restart combination instrument or **Pairing** repeat procedure.

A suitable cellphone can be paired with the combination instrument in the **Phone** submenu.

7.26.6 Headset

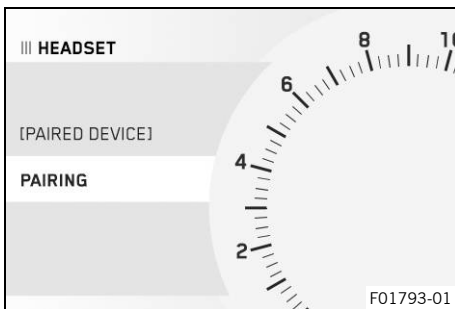

Condition

- The motorcycle is stationary.
- **Bluetooth** function is activated.
- The **Bluetooth**® function should also be activated in the device to be paired.
 - Press the **SET** button when the menu is closed.
 - Press the **UP** or **DOWN** button until **KTM MY RIDE** is marked. Press the **SET** button to open the menu.
 - Press the **UP** or **DOWN** button until **Pairing** is marked. Press the **SET** button to open the submenu.
 - Press the **UP** or **DOWN** button until **Headset** is marked. Press the **SET** button to open the submenu.
 - Press the **UP** or **DOWN** button until **Pairing** is marked. Press the **SET** button to open the submenu.
- The combination instrument starts searching for a suitable headset. If the search was successful, the name of the headset is displayed in the **Pairing** submenu. Press the **SET** button to select the device. Press the **SET** button again to confirm the **Confirm** submenu item. The pairing of a headset with the combination instrument is now completed.



Info

The headset must be in pairing mode for the headset to be found by the combination instrument. Follow the instructions in the Owner's Manual of the headset. Once the pairing is completed, the name of the paired headset is displayed in the **Headset** submenu. Press the **UP** or **DOWN** button until the paired device is marked. The paired device can be deleted by pressing the **SET** button. Not every headset is suitable for pairing with the combination instrument.

- Move the previously paired device into the range of the combination instrument while the **Bluetooth**® function is active.
 - ✓ The device is automatically paired with the combination instrument.
 - ✗ If the device is not automatically paired with the combination instrument after approx. 30 seconds:
 - Restart combination instrument or **Pairing** repeat procedure.

A suitable headset can be paired with the combination instrument in the **Headset** submenu.

7.26.7 Telephony

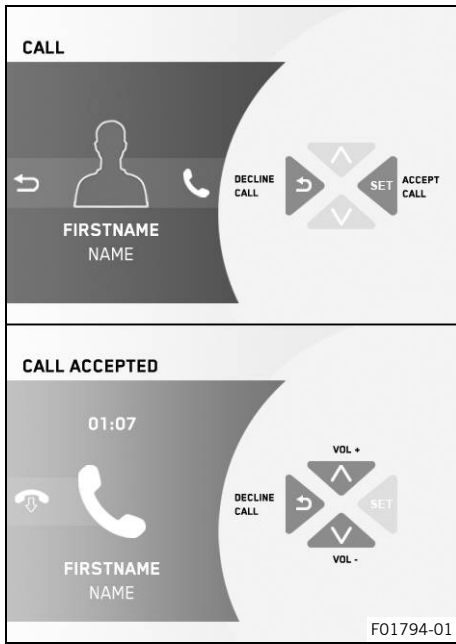

Condition

- **Bluetooth®** function is activated.
- The **Bluetooth®** function should also be activated in the device to be paired.
- The combination instrument is connected to a suitable cell-phone.
- The combination instrument is connected to a suitable headset.



Warning

Danger of accidents Headphone volume which is too high distracts attention from traffic activity.

- Always select headphone volume which is low enough for you to still clearly hear acoustic signals.

- Press the **SET** button to accept an incoming call.
- Press the **BACK** button to reject an incoming call.
- Press and hold **UP** button to increase the audio volume.
- Press and hold **DOWN** button to reduce the audio volume.



Info

It is not possible to change the audio volume using the combination switch with every cellphone.

The call duration and contact are displayed. Depending on the cellphone settings, the contact is shown by name.

An incoming call is visualized in a small window at the top of the combination instrument display when the navigation function is active.

You cannot navigate in the menu during an active phone conversation.

7.26.8 Trips/Data

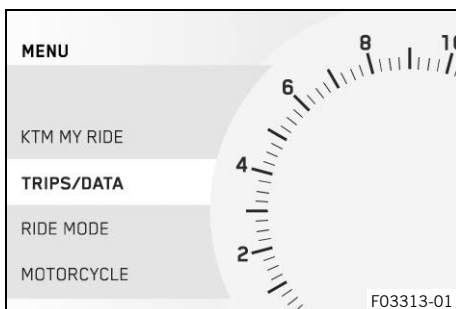

- Press the **SET** button when the menu is closed.
- Press the **UP** or **DOWN** button until **Trips/Data** is marked. Press the **SET** button to open the menu.

General information can be accessed in the **Trips/Data** menu.

7.26.9 General Info

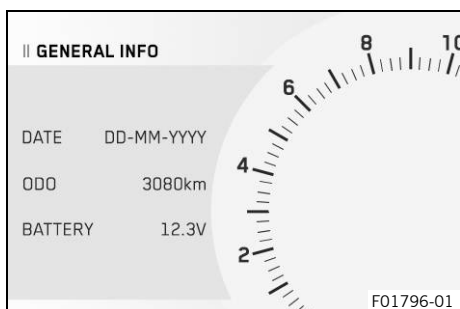

- Press the **SET** button when the menu is closed.
- Press the **UP** or **DOWN** button until **Trips/Data** is marked. Press the **SET** button to open the menu.
- Press the **UP** or **DOWN** button until **General Info** is marked. Press the **SET** button to open the submenu.

In the submenu **General Info**, the date, total route ridden and battery voltage of the 12-V battery can be viewed.



Info

Date shows the date.

ODO shows the total distance covered.

Battery shows the battery voltage of the 12-V battery.

7.26.10 Trip 1

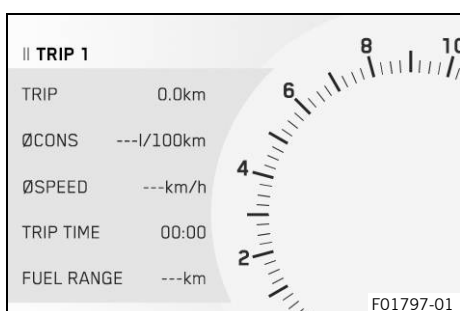

- Press the **SET** button when the menu is closed.
- Press the **UP** or **DOWN** button until **Trips/Data** is marked. Press the **SET** button to open the menu.
- Press the **UP** or **DOWN** button until **Trip 1** is marked. Press the **SET** button to open the submenu.

Information on **Trip 1** can be viewed in the **Trip 1** submenu.



Info

Trip shows the distance since the last reset, such as between two refueling stops. **Trip** is running and counts up to **9999**.

ØCons indicates the average fuel consumption based on **Trip**.

ØSpeed indicates the average speed based on **Trip** and **Trip Time**.

Trip Time shows the journey time on the basis of **Trip** and runs as soon as a speed signal is received.

Fuel Range indicates the possible distance you can cover with the fuel reserve.

Press and hold the **SET** button for 3 - 5 seconds.

All the entries in the **Trip 1** submenu are reset.

7.26.11 Trip 2

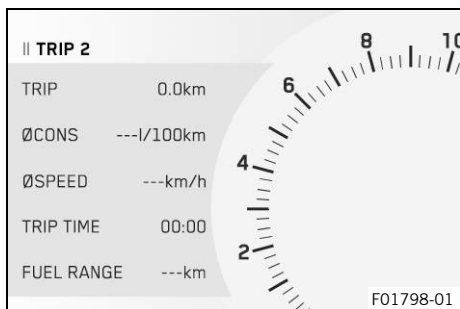

- Press the **SET** button when the menu is closed.
- Press the **UP** or **DOWN** button until **Trips/Data** is marked. Press the **SET** button to open the menu.
- Press the **UP** or **DOWN** button until **Trip 2** is marked. Press the **SET** button to open the submenu.

Information on **Trip 2** can be viewed in the **Trip 2** submenu.

i Info

Trip shows the distance since the last reset, such as between two refueling stops. **Trip** is running and counts up to **9999**.

ØCons indicates the average fuel consumption based on **Trip**.

ØSpeed indicates the average speed based on **Trip** and **Trip Time**.

Trip Time shows the journey time on the basis of **Trip** and runs as soon as a speed signal is received.

Fuel Range indicates the possible distance you can cover with the fuel reserve.

Press and hold the **SET** button for 3 - 5 seconds.

All the entries in the **Trip 2** submenu are reset.

7.26.12 TPMS (function optional)

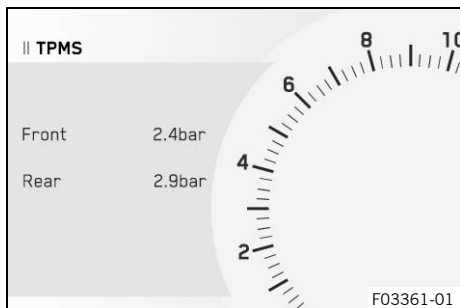

Condition

- Model with **TPMS**.
- Press the **SET** button when the menu is closed.
- Press the **UP** or **DOWN** button until **Trips/Data** is marked. Press the **SET** button to open the menu.



Warning

Danger of accidents The tire pressure monitoring system does not eliminate the necessity to check the tires before going on a ride.

To avoid false alarms, the tire pressure values are evaluated over a period of several minutes.

- Check the tire pressure before every ride.
- Correct the tire pressure if the tire pressure deviates from the specified value.
- Even if the tire pressure values are correct, stop the vehicle immediately if its behavior indicates a loss of pressure in the tires.

- Press the **UP** or **DOWN** button until **TPMS** is marked. Press the **SET** button to open the submenu.

Guideline

Tire pressure, solo / with passenger / full payload	
front: with cold tires	2.4 bar (35 psi)
rear: with cold tires	2.9 bar (42 psi)

The tire pressure of the front and rear tires can be viewed in the **TPMS** submenu.

i Info

Front indicates the tire pressure at the front.

Rear indicates the tire pressure at the rear.

7.26.13 Warning

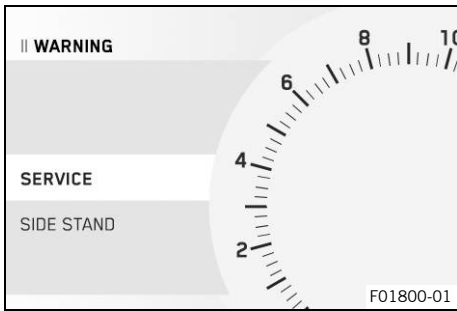

Condition

- Message or warning is present.
- Press the **SET** button when the menu is closed.
- Press the **UP** or **DOWN** button until **Trips/Data** is marked. Press the **SET** button to open the menu.
- Press the **UP** or **DOWN** button until **Warning** is marked. Press the **SET** button to open the submenu.
- Use the **UP** or **DOWN** button to navigate through the warnings.



Info

The warnings that have occurred are saved in the display until they are no longer active.

7.26.14 Ride Mode

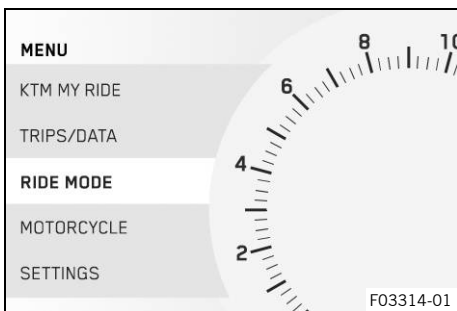

- Press the **SET** button when the menu is closed.



Warning

Danger of accidents An incorrectly selected riding mode makes control of the vehicle considerably more difficult.

The riding modes are each only suitable for certain conditions.

- Always select a riding mode that suits the surface on which you are riding, the weather and the riding situation.

- Press the **UP** or **DOWN** button until **Ride Mode** is marked. Press the **SET** button to open the menu.

The riding mode of the vehicle can be configured in the **Ride Mode** menu.

7.26.15 Ride Mode

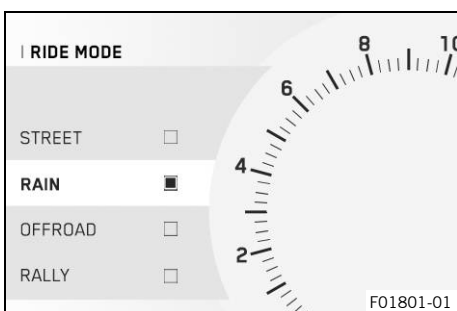

Condition

- Emergency off switch deactivated.
- Cruise control system function (optional) deactivated.
- Press the **SET** button when the menu is closed.
- Press the **UP** or **DOWN** button until **Ride Mode** is marked. Press the **SET** button to open the menu.
- Press the **UP** or **DOWN** button until **Ride Mode** is marked on the display. Press the **SET** button to open the submenu.
- Activate menu item using the **UP** or **DOWN** button.



Warning

Danger of accidents An incorrectly selected riding mode makes control of the vehicle considerably more difficult.

The riding modes are each only suitable for certain conditions.

- Always select a riding mode that suits the surface on which you are riding, the weather and the riding situation.

- Press the **SET** button to select the engine and motorcycle traction control settings that are coordinated with each other.
 - ✓ Street – homologated performance with balanced response; the motorcycle traction control allows normal slip on the rear wheel. The Anti-wheelie mode is active.
 - ✓ Rain – reduced homologated performance for better rideability; the motorcycle traction control allows normal slip on the rear wheel. The Anti-wheelie mode is active.
 - ✓ Offroad – reduced homologated performance for better rideability; the motorcycle traction control allows high slip on the rear wheel. The Anti-wheelie mode is deactivated.
 - ✓ Rally (optional) – setting with homologated performance and extremely direct response. The motorcycle traction control and the characteristic map of the throttle response can be individually set. The Anti-Wheelie mode is deactivated.



Info

Do not open the throttle during the selection.

7.26.16 Rally (optional)

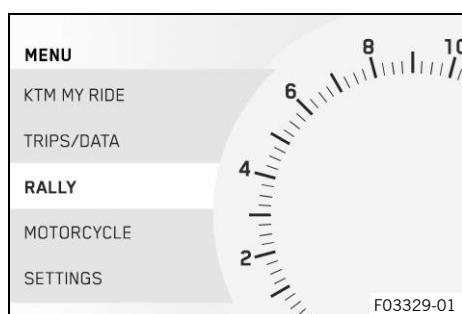

Condition

- Model with **RALLY PACK**.
- The riding mode **Rally** (optional) is activated.
- Press the **SET** button when the menu is closed.



Warning

Danger of accidents An incorrectly selected riding mode makes control of the vehicle considerably more difficult.

The riding modes are each only suitable for certain conditions.

- Always select a riding mode that suits the surface on which you are riding, the weather and the riding situation.

- Press the **UP** or **DOWN** button until **Rally** is marked on the display. Press the **SET** button to open the menu.

The individual settings of the **RALLY PACK** can be adjusted in the **Rally** menu.

7.26.17 Throttle Response (optional)

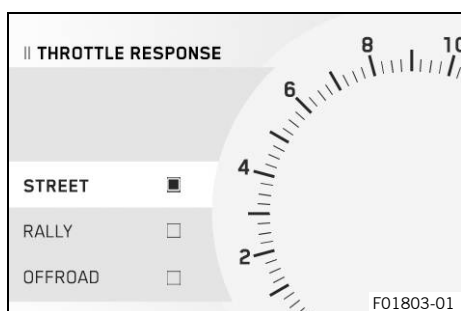
**Condition**

- Model with **RALLY PACK**.
- The riding mode **Rally** (optional) is activated.
- Press the **SET** button when the menu is closed.

**Warning**

Danger of accidents An incorrectly selected riding mode makes control of the vehicle considerably more difficult.

The riding modes are each only suitable for certain conditions.

- Always select a riding mode that suits the surface on which you are riding, the weather and the riding situation.

- Press the **UP** or **DOWN** button until **Rally** is marked on the display. Press the **SET** button to open the menu.
- Press the **UP** or **DOWN** button until **Throttle Response** is marked on the display. Press the **SET** button to open the submenu.
- Activate menu item using the **UP** or **DOWN** button.
- The characteristic map of the throttle response can be adjusted by pressing the **SET** button.
 - ✓ Street – balanced response.
 - ✓ Rally – extremely direct response.
 - ✓ Offroad – very direct response.

**Info**

Do not open the throttle when setting.

7.26.18 Leave Rally (optional)

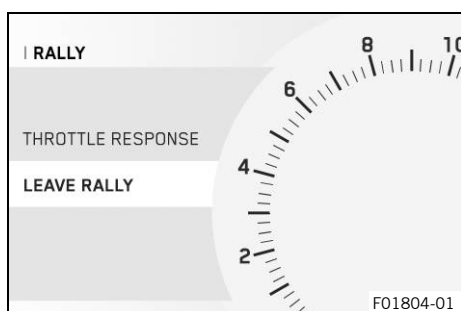
**Condition**

- Model with **RALLY PACK**.
- The riding mode **Rally** (optional) is activated.
- Press the **SET** button when the menu is closed.

**Warning**

Danger of accidents An incorrectly selected riding mode makes control of the vehicle considerably more difficult.

The riding modes are each only suitable for certain conditions.

- Always select a riding mode that suits the surface on which you are riding, the weather and the riding situation.

- Press the **UP** or **DOWN** button until **Rally** is marked on the display. Press the **SET** button to open the menu.

- Press the **UP** or **DOWN** button until **Leave Rally** is marked on the display. Press the **SET** button to end drive mode **Rally** and automatically switch to drive mode **Street**.



Info

Do not open the throttle when deactivating drive mode **Rally**.

7.26.19 Motorcycle

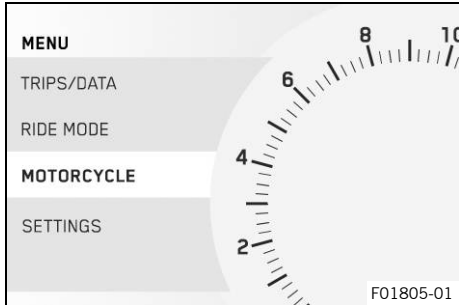

- Press the **SET** button when the menu is closed.
- Press the **UP** or **DOWN** button until **Motorcycle** is marked. Press the **SET** button to open the menu.

In the **Motorcycle** menu, the motorcycle traction control, the engine traction torque control (optional) and the Quickshifter + (optional) can be switched on or off and the ABS, heated grip and seat heater can be configured.

7.26.20 MTC

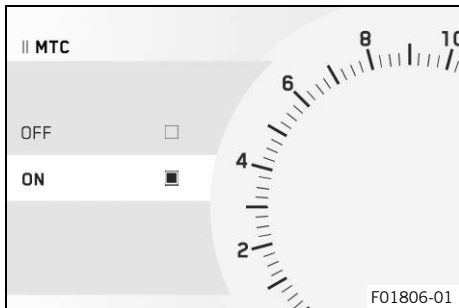

Condition

- Cruise control system function (optional) deactivated.
- Press the **SET** button when the menu is closed.
- Press the **UP** or **DOWN** button until **Motorcycle** is highlighted. Press the **SET** button to open the menu.
- Press the **UP** or **DOWN** button until **MTC** is highlighted. Press the **SET** button to open the submenu.
- Activate the menu item using the **UP** or **DOWN** button.
- Switch **MTC** on or off by pressing the **SET** button.



Info

Do not open the throttle when switching on or off. Press the **SET** button briefly when activating the motorcycle traction control. Hold down the **SET** button when switching off the motorcycle traction control. After the ignition is switched on, motorcycle traction control is enabled again.

Press and hold the SET button for 3 - 5 seconds.	Switching off the motorcycle traction control.
---	--

7.26.21 MTC+MSR (optional)

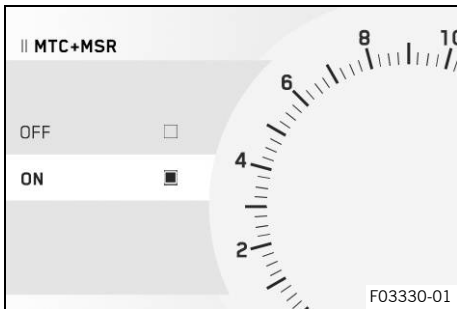

Condition

- Model with **MTC+MSR**.
- Cruise control system function (optional) deactivated.
- Press the **SET** button when the menu is closed.
- Press the **UP** or **DOWN** button until **Motorcycle** is highlighted. Press the **SET** button to open the menu.
- Press the **UP** or **DOWN** button until **MTC+MSR** is highlighted. Press the **SET** button to open the menu.
- Activate the menu item using the **UP** or **DOWN** button.
- Switch **MTC+MSR** on or off by pressing the **SET** button.



Info

Do not open the throttle when switching on or off. Press the **SET** button briefly when activating the motorcycle traction control and the engine traction torque control.

Hold down the **SET** button when switching off the motorcycle traction control and engine traction torque control.

When ABS mode **Offroad** is active, the **MSR** is not active.

After the ignition is switched on, the motorcycle traction control and engine traction torque control are enabled again.

Press and hold the **SET** button for 3 - 5 seconds.

Switching off the motorcycle traction control and the engine traction torque control.

7.26.22 ABS

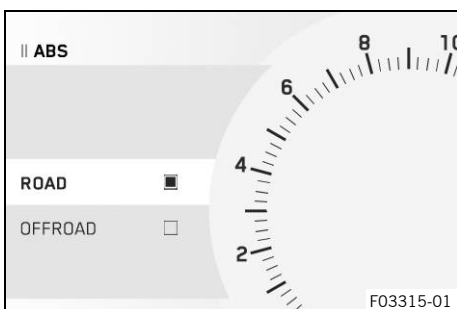

- Press the **SET** button when the menu is closed.
- Press the **UP** or **DOWN** button until **Motorcycle** is highlighted. Press the **SET** button to open the menu.
- Press the **UP** or **DOWN** button until **ABS** is highlighted. Press the **SET** button to open the submenu.
- Activate the menu item using the **UP** or **DOWN** button.



Warning

Danger of accidents An incorrectly selected ABS mode makes control of the vehicle considerably more difficult.

The ABS modes are each only suitable for certain conditions.

- Always select an ABS mode that is compatible with the surface of the ground.

- Press the **SET** button to select the desired ABS mode.



Info

The ABS mode can be switched during the journey. Do not open the throttle during the selection. When the ABS mode **Road** is active, ABS controls both wheels. When the **Offroad** ABS mode is active, ABS only controls the front wheel. The rear wheel is not controlled by ABS and may lock during braking maneuvers.

7.26.23 Heating Grip (function optional)

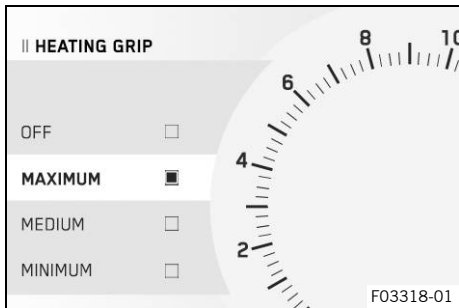

Condition

- Model with grip heater.
- **Heating Grip** menu (optional function) activated.
- Press the **SET** button when the menu is closed.
- Press the **UP** or **DOWN** button until **Motorcycle** is highlighted. Press the **SET** button to open the menu.
- Press the **UP** or **DOWN** button until **Heating Grip** is highlighted. Press the **SET** button to open the menu.
- Activate the menu item using the **UP** or **DOWN** button.
- Press the **SET** button to select the heating level or to switch the heated grip on or off.

7.26.24 Heating Seat Rider (function optional)

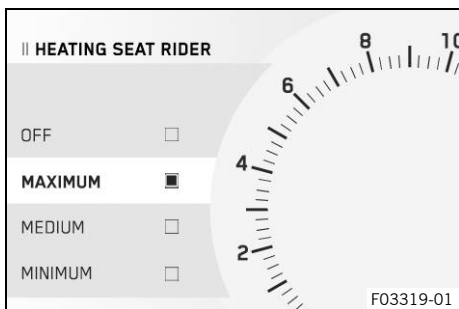

Condition

- Model with seat heater.
- **Heating Seat Rider** menu (optional function) activated.
- **Heating Seat Pillion** menu (optional function) activated.
- Press the **SET** button when the menu is closed.
- Press the **UP** or **DOWN** button until **Motorcycle** is highlighted. Press the **SET** button to open the menu.
- Press the **UP** or **DOWN** button until **Heating Seat Rider** is highlighted. Press the **SET** button to open the menu.
- Activate the menu item using the **UP** or **DOWN** button.
- Press the **SET** button to select the heating level or to switch the front rider's seat heating on or off.



Info

The heating level for the passenger seat heating is selected using the switch next to the right grab handle.

7.26.25 Quick Shift+ (optional)

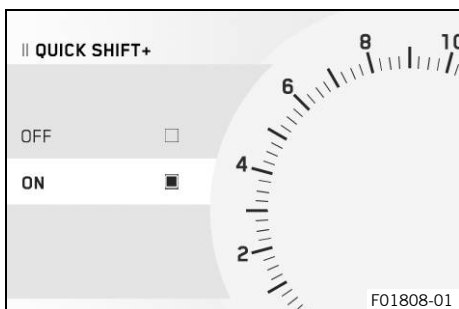

Condition

- Model with Quickshifter+.
- Press the **SET** button when the menu is closed.
- Press the **UP** or **DOWN** button until **Motorcycle** is highlighted. Press the **SET** button to open the menu.
- Press the **UP** or **DOWN** button until **Quick Shift+** is highlighted. Press the **SET** button to open the submenu.
- Activate the menu item using the **UP** or **DOWN** button.

- Press the **SET** button to switch quickshifter + (🗨 p. 69) button on or off.

7.26.26 Settings

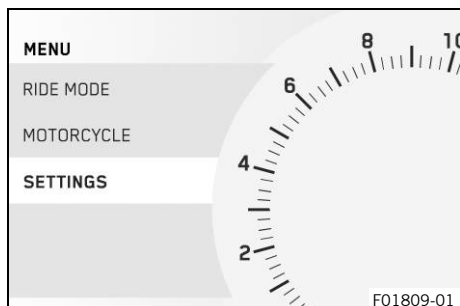

Condition

- The motorcycle is stationary.
- Press the **SET** button when the menu is closed.
- Press the **UP** or **DOWN** button until **Settings** is marked. Press the **SET** button to open the menu.

In the **Settings** menu, favorites, quick selections and the combination instrument display can be configured. Settings can be made for units or various values. Several functions can be enabled or disabled.

7.26.27 Favorites

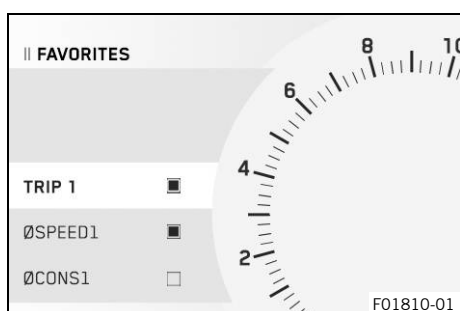

Condition

- The motorcycle is stationary.
- Press the **SET** button when the menu is closed.
- Press the **UP** or **DOWN** button until **Settings** is marked. Press the **SET** button to open the menu.
- Press the **UP** or **DOWN** button until **Favorites** is marked. Press the **SET** button to open the submenu.
- Access menu item with the **UP** or **DOWN** button, and add the selected information to the **SET** display using the **Favorites** button.

Up to eight items of information can be selected in the **Favorites** menu.

7.26.28 Quick Selector 1

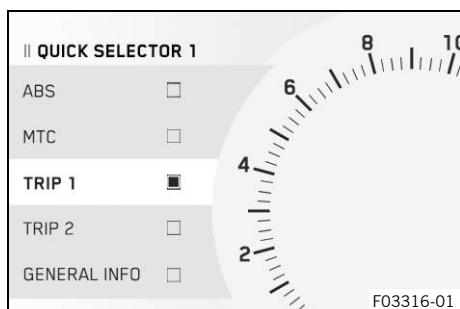

Condition

- The motorcycle is stationary.
- Press the **SET** button when the menu is closed.
- Press the **UP** or **DOWN** button until **Settings** is marked. Press the **SET** button to open the menu.
- Press the **UP** or **DOWN** button until **Quick Selector 1** is marked. Press the **SET** button to open the menu.
- Activate menu item using the **UP** or **DOWN** button.
- Press the **SET** button to set a submenu for direct dialing for **Quick Selector 1**.



Info

When the menu is closed, the submenu defined in **Quick Selector 1** is opened by pressing the **UP** button.

7.26.29 Quick Selector 2

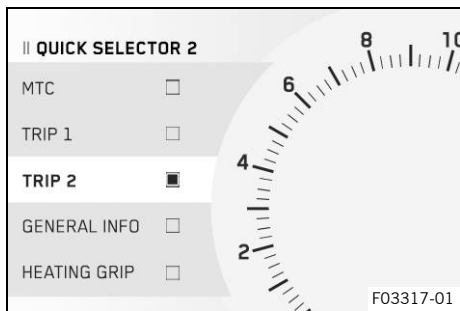

Condition

- The motorcycle is stationary.
- Press the **SET** button when the menu is closed.
- Press the **UP** or **DOWN** button until **Settings** is marked. Press the **SET** button to open the menu.
- Press the **UP** or **DOWN** button until **Quick Selector 2** is marked. Press the **SET** button to open the menu.
- Activate menu item using the **UP** or **DOWN** button.
- Press the **SET** button to set a submenu for direct dialing for **Quick Selector 2**.

Info

When the menu is closed, the submenu defined in **Quick Selector 2** is opened by pressing the **DOWN** button.

7.26.30 Bluetooth

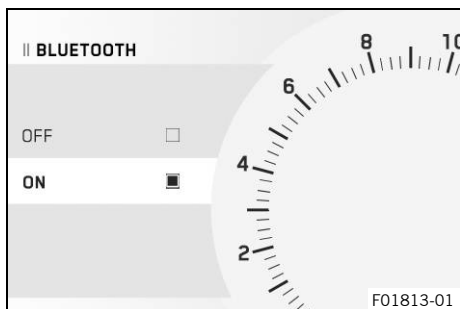

Condition

- The motorcycle is stationary.
- Press the **SET** button when the menu is closed.
- Press the **UP** or **DOWN** button until **Settings** is marked. Press the **SET** button to open the menu.
- Press the **UP** or **DOWN** button until **Bluetooth** is marked. Press the **SET** button to open the submenu.
- Activate menu item using the **UP** or **DOWN** button.
- Press the **SET** button to switch the **Bluetooth**® function on or off.

Info

The **Bluetooth**® function can only be used in conjunction with **KTM MY RIDE**. If a device has been paired via the submenu **Pairing** but is currently not connected, the **Bluetooth**® symbol flashes when the **Bluetooth**® function is switched on. The **Bluetooth**® symbol lights up as soon as a device is connected.

7.26.31 Display Theme

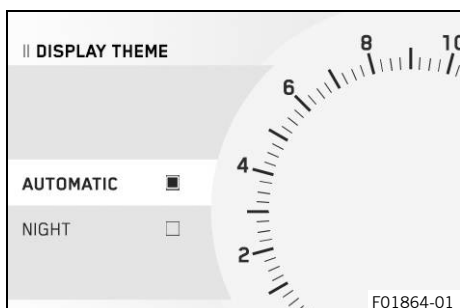

Condition

- The motorcycle is stationary.
- Press the **SET** button when the menu is closed.
- Press the **UP** or **DOWN** button until **Settings** is marked. Press the **SET** button to open the menu.
- Press the **UP** or **DOWN** button until **Display Theme** is marked. Press the **SET** button to open the submenu.
- Activate menu item using the **UP** or **DOWN** button.
- Press the **SET** button to set up automatic day-night mode or permanent night mode.

i Info

In both modes, the display is brightened or dimmed depending on the amount of ambient light.

7.26.32 Shift Light

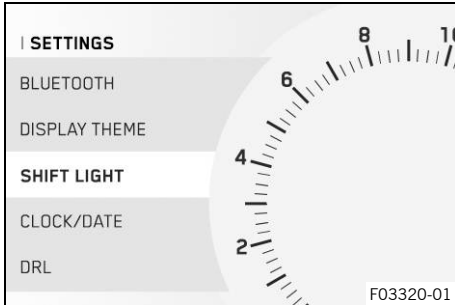

Condition

- The motorcycle is stationary.
- **ODO** > 1,000 km (621 mi).
- Press the **SET** button when the menu is closed.
- Press the **UP** or **DOWN** button until **Settings** is marked. Press the **SET** button to open the menu.
- Press the **UP** or **DOWN** button until **Shift Light** is marked. Press the **SET** button to open the submenu.

The shift warning light can be configured in the **Shift Light** submenu.

7.26.33 RPM1

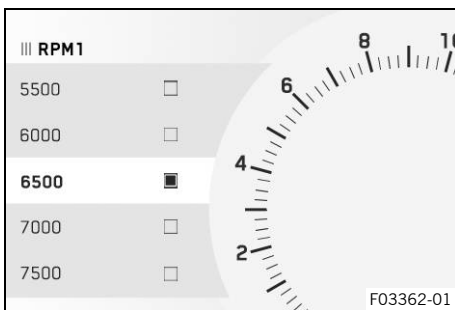

Condition

- The motorcycle is stationary.
- **ODO** > 1,000 km (621 mi).
- Press the **SET** button when the menu is closed.
- Press the **UP** or **DOWN** button until **Settings** is marked. Press the **SET** button to open the menu.
- Press the **UP** or **DOWN** button until **Shift Light** is marked. Press the **SET** button to open the submenu.
- Press the **UP** or **DOWN** button until **RPM1** is marked. Press the **SET** button to open the submenu.
- Activate menu item using the **UP** or **DOWN** button.
- Set the value for **SET** by pressing the **RPM1** button.

i Info

If the engine speed reaches the set value **RPM1**, the shift warning light flashes.

7.26.34 RPM2

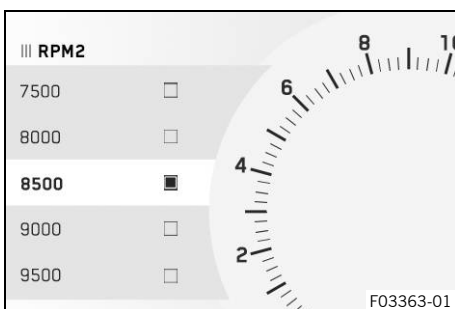

Condition

- The motorcycle is stationary.
- **ODO** > 1,000 km (621 mi).
- Press the **SET** button when the menu is closed.
- Press the **UP** or **DOWN** button until **Settings** is marked. Press the **SET** button to open the menu.
- Press the **UP** or **DOWN** button until **Shift Light** is marked. Press the **SET** button to open the submenu.
- Press the **UP** or **DOWN** button until **RPM2** is marked. Press the **SET** button to open the submenu.
- Activate menu item using the **UP** or **DOWN** button.
- Set the value for **SET** by pressing the **RPM2** button.



Info

If the engine speed reaches the set value **RPM2**, the shift warning light flashes and the color changes.

7.26.35 Shift Light

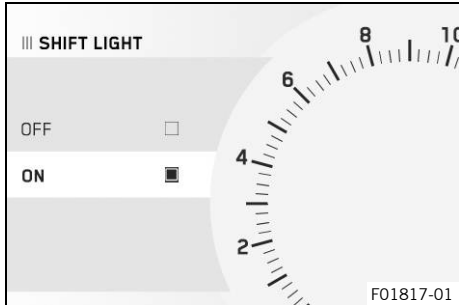

Condition

- The motorcycle is stationary.
 - **ODO** > 1,000 km (621 mi).
- Press the **SET** button when the menu is closed.
 - Press the **UP** or **DOWN** button until **Settings** is marked. Press the **SET** button to open the menu.
 - Press the **UP** or **DOWN** button until **Shift Light** is marked. Press the **SET** button to open the submenu.
 - Press the **UP** or **DOWN** button until **Shift Light** is marked. Press the **SET** button to open the submenu.
 - Activate menu item using the **UP** or **DOWN** button.
 - Press the **SET** button to switch the shift warning light on or off.

7.26.36 Setting the time and date

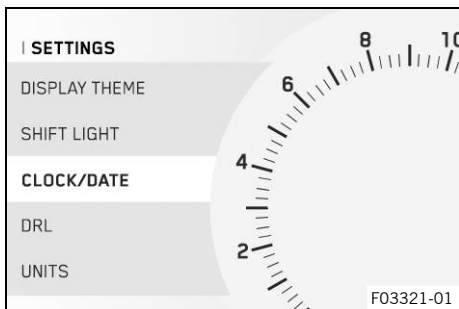

Condition

The motorcycle is stationary.

- Press the **SET** button when the menu is closed.
- Press **UP** or **DOWN** button until **Settings** appears. Press the **SET** button to open the menu.
- Press the **UP** or **DOWN** button until **Clock/Date** is marked. Press the **SET** button to open the submenu.

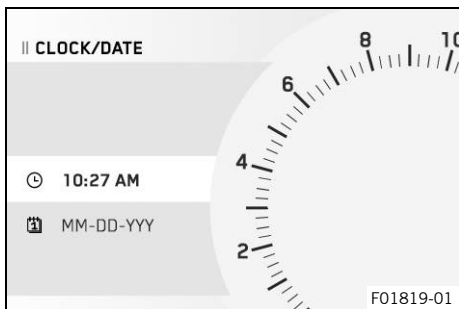

Setting the clock

- Press **UP** or **DOWN** button until the time is marked.
- Press the **SET** button.
 - ✓ The hour flashes and is underlined.
- Press **UP** or **DOWN** button until the current hour is set.
- Press the **SET** button.
 - ✓ The minutes flash and are underlined.
- Press **UP** or **DOWN** button until the current minute is set.
- Press **SET** button.
 - ✓ The time is stored.

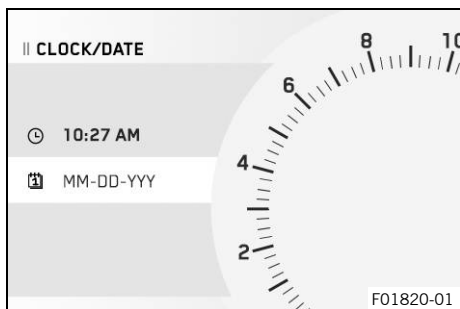

Setting the date

- Press **UP** or **DOWN** button until the date is marked.
- Press **SET** button.
 - ✓ The day flashes and is underlined.
- Press **UP** or **DOWN** button until the current day is set.
- Press **SET** button.
 - ✓ The month flashes and is underlined.
- Press **UP** or **DOWN** button until the current month is set.
- Press the **SET** button.
 - ✓ The year flashes and is underlined.
- Press **UP** or **DOWN** button until the current year is set.
- Press **SET** button.
 - ✓ The date is stored.



7.26.37 DRL

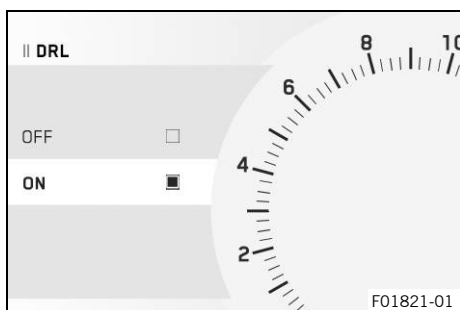

Condition

- The motorcycle is stationary.
 - Press the **SET** button when the menu is closed.
 - Press the **UP** or **DOWN** button until **Settings** is marked. Press the **SET** button to open the menu.
 - Press the **UP** or **DOWN** button until **DRL** is marked. Press the **SET** button to open the submenu.



Warning

Danger of accidents When visibility is poor, the daytime running light is not a substitute for the low beam. Automatic switching between the daytime running light and low beam may only be partially available when visibility is significantly impaired due to fog, snow or rain.

- Ensure that the appropriate type of lighting is always selected.
- If necessary switch off the daytime running lights using the menu before going on a ride or when stopped so that the low beam is switched on permanently.
- Make sure that the daytime running light is deactivated with the diagnostics tool when the menu item is not available, but the low beam is required. (Your authorized KTM workshop will be glad to help.)
- Note the legal regulations regarding the daytime running light.

- Activate menu item using the **UP** or **DOWN** button.
- Press the **SET** button to switch the daytime running light on or off.

7.26.38 Units

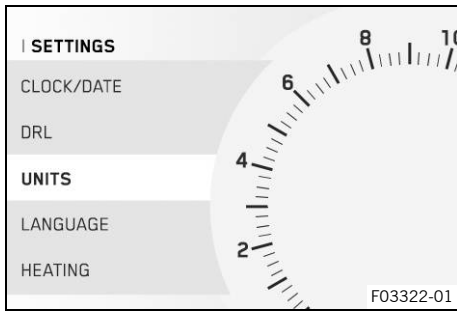

Condition

- The motorcycle is stationary.
- Press the **SET** button when the menu is closed.
- Press the **UP** or **DOWN** button until **Settings** is marked. Press the **SET** button to open the menu.
- Press the **UP** or **DOWN** button until **Units** is marked. Press the **SET** button to open the submenu.

The **Units** submenu allows settings to be made for units or various values.

7.26.39 Distance

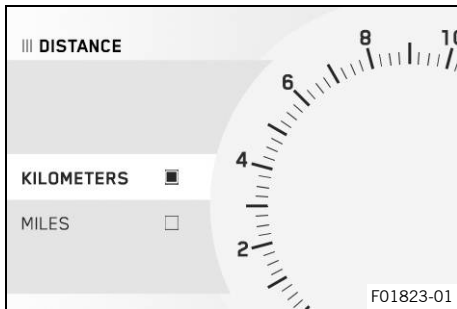

Condition

- The motorcycle is stationary.
- Press the **SET** button when the menu is closed.
- Press the **UP** or **DOWN** button until **Settings** is marked. Press the **SET** button to open the menu.
- Press the **UP** or **DOWN** button until **Units** is marked. Press the **SET** button to open the submenu.
- Press the **UP** or **DOWN** button until **Distance** is marked. Press the **SET** button to open the submenu.
- Activate the menu item using the **UP** or **DOWN** button.
- Press the **SET** button to confirm the desired unit.

7.26.40 Temperature

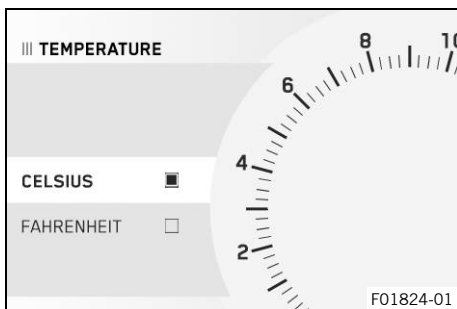

Condition

- The motorcycle is stationary.
- Press the **SET** button when the menu is closed.
- Press the **UP** or **DOWN** button until **Settings** is marked. Press the **SET** button to open the menu.
- Press the **UP** or **DOWN** button until **Units** is marked. Press the **SET** button to open the submenu.
- Press the **UP** or **DOWN** button until **Temperature** is marked. Press the **SET** button to open the submenu.
- Activate the menu item using the **UP** or **DOWN** button.
- Press the **SET** button to confirm the desired unit.

7.26.41 Fuel Cons

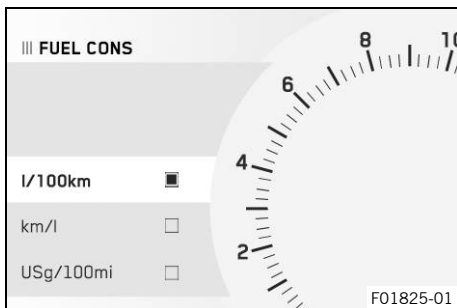

Condition

- The motorcycle is stationary.
- Press the **SET** button when the menu is closed.
- Press the **UP** or **DOWN** button until **Settings** is marked. Press the **SET** button to open the menu.
- Press the **UP** or **DOWN** button until **Units** is marked. Press the **SET** button to open the submenu.
- Press the **UP** or **DOWN** button until **Fuel Cons** is marked. Press the **SET** button to open the submenu.
- Activate the menu item using the **UP** or **DOWN** button.
- Press the **SET** button to confirm the desired unit.

7.26.42 Language

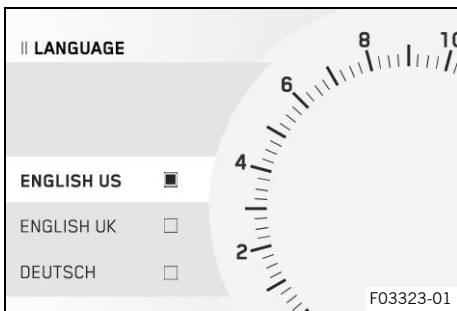
**Condition**

- The motorcycle is stationary.
- Press the **SET** button when the menu is closed.
- Press the **UP** or **DOWN** button until **Settings** is marked. Press the **SET** button to open the menu.
- Press the **UP** or **DOWN** button until **Language** is marked. Press the **SET** button to open the submenu.
- Activate menu item using the **UP** or **DOWN** button.
- Press the **SET** button to confirm the desired language.

**Info**

The menu languages are US English, UK English, German, Italian, French, and Spanish.

7.26.43 Heating (function optional)

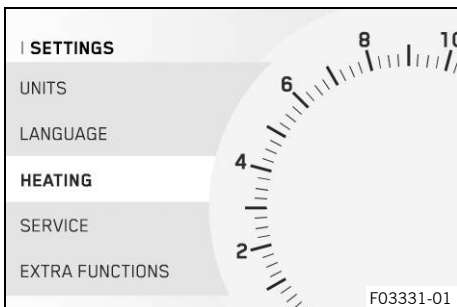
**Condition**

- The motorcycle is stationary.
- Press the **SET** button when the menu is closed.
- Press the **UP** or **DOWN** button until **Settings** is highlighted. Press the **SET** button to open the menu.
- Press the **UP** or **DOWN** button until **Heating** is highlighted. Press the **SET** button to open the submenu.

The heated grip, rider seat heating and passenger seat heating can be configured in the **Heating** submenu.

**Info**

In the **Settings** menu, the **Heating** submenu solely controls the visibility of **Heating Grip** and **Heating Seat** in the **Motorcycle** menu.

7.26.44 Heating Grip (function optional)

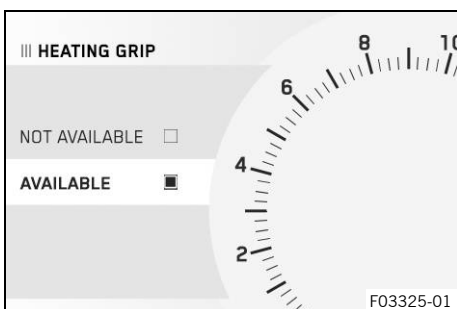
**Condition**

- Model with heated grip.
- The motorcycle is stationary.
- Press the **SET** button when the menu is closed.
- Press the **UP** or **DOWN** button until **Settings** is highlighted. Press the **SET** button to open the menu.
- Press the **UP** or **DOWN** button until **Heating** is highlighted. Press the **SET** button to open the submenu.
- Press the **UP** or **DOWN** button until **Heating Grip** is marked. Press the **SET** button to open the submenu.
- Activate the menu item using the **UP** or **DOWN** button.
- Press the **SET** button to switch the heated grip on or off.

7.26.45 Heating Seat Rider (function optional)

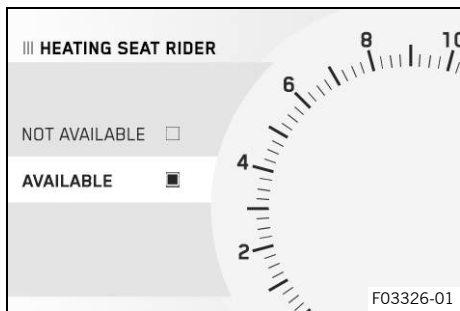

Condition

- Model with seat heater.
- The motorcycle is stationary.
- Press the **SET** button when the menu is closed.
- Press the **UP** or **DOWN** button until **Settings** is highlighted. Press the **SET** button to open the menu.
- Press the **UP** or **DOWN** button until **Heating** is highlighted. Press the **SET** button to open the submenu.
- Press the **UP** or **DOWN** button until **Heating Seat Rider** is marked. Press the **SET** button to open the submenu.
- Activate the menu item using the **UP** or **DOWN** button.
- Press the **SET** button to switch the front rider's seat heating on or off.

7.26.46 Heating Seat Pillion (function optional)

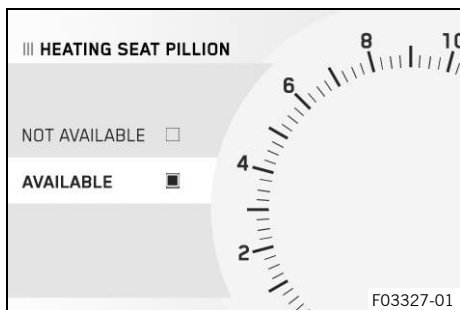

Condition

- Model with seat heater.
- The motorcycle is stationary.
- Press the **SET** button when the menu is closed.
- Press the **UP** or **DOWN** button until **Settings** is highlighted. Press the **SET** button to open the menu.
- Press the **UP** or **DOWN** button until **Heating** is highlighted. Press the **SET** button to open the submenu.
- Press the **UP** or **DOWN** button until **Heating Seat Pillion** is marked. Press the **SET** button to open the submenu.
- Activate the menu item using the **UP** or **DOWN** button.
- Press the **SET** button to switch the passenger seat heating on or off.

7.26.47 Service

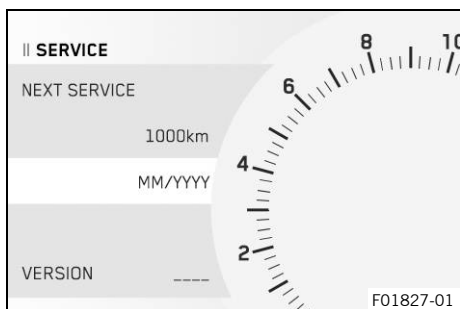

Condition

- The motorcycle is stationary.
- Press the **SET** button when the menu is closed.
- Press the **UP** or **DOWN** button until **Settings** is marked. Press the **SET** button to open the menu.
- Press the **UP** or **DOWN** button until **Service** is marked. Press the **SET** button to open the submenu.
- Use the **UP** or **DOWN** button to navigate through the information.

Info

The remaining kilometers / duration until the next due service and the currently installed software version are displayed.

7.26.48 Extra Functions

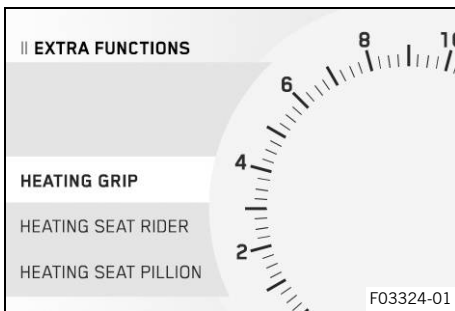
**Condition**

- The motorcycle is stationary.
- Motorcycle with optional supplementary function.
 - Press the **SET** button when the menu is closed.
 - Press the **UP** or **DOWN** button until **Settings** is marked. Press the **SET** button to open the menu.
 - Press the **UP** or **DOWN** button until **Extra Functions** is marked. Press the **SET** button to open the submenu.
 - Use the **UP** or **DOWN** button to navigate through the extra functions.

**Info**

The optional extra functions are listed. The current **KTM PowerParts** and the available software for your vehicle can be found on the KTM website.

8.1 Handlebar position

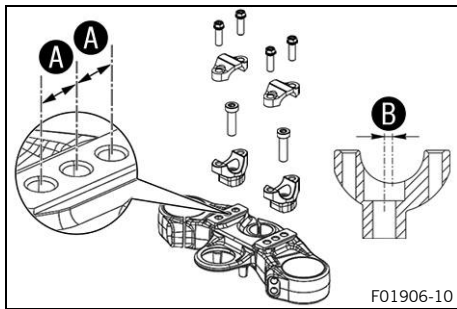

On the upper triple clamp, there are three holes at a distance of **A** to each other.

The holes on the handlebar support are placed at a distance of **B** from the center.

Hole distance A	15 mm (0.59 in)
Hole distance B	3.5 mm (0.138 in)

The handlebar can be mounted in six different positions. This allows the handlebar to be mounted in the most comfortable position for the rider.

8.2 Adjusting the handlebar position ↩



Warning

Danger of accidents A repaired handlebar poses a safety risk.

If the handlebar is bent or straightened, the material becomes fatigued. The handlebar may break as a result.

- Change the handlebar if the handlebar is damaged or bent.

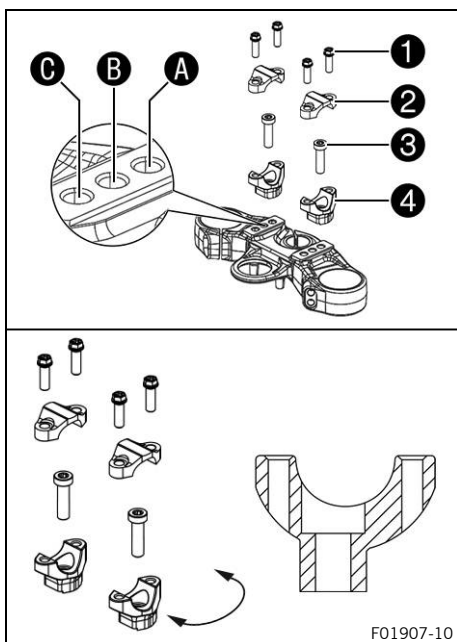

- Remove screws **1**. Take off the handlebar clamps **2**. Position the handlebar so that screws **3** are accessible.



Info

Cover the components to protect them against damage. Do not kink the cables and lines.

- Remove screws **3**. Take off handlebar supports **4**.
- Move the handlebar supports into the desired position **B**, **A** or **C**. Mount and tighten screws **3**.

Guideline

Mount the left and right handlebar supports in the same position.

Screw, handlebar support	M10	45 Nm (33.2 lbf ft) Loctite®243™
--------------------------	-----	--

- Position the handlebar.



Info

Make sure the cables and wiring are positioned correctly.

- Position handlebar clamp. Mount screws **1** and tighten evenly.

Guideline

Screw, handlebar clamp	M8	20 Nm (14.8 lbf ft)
------------------------	----	---------------------

8.3 Adjusting the windshield

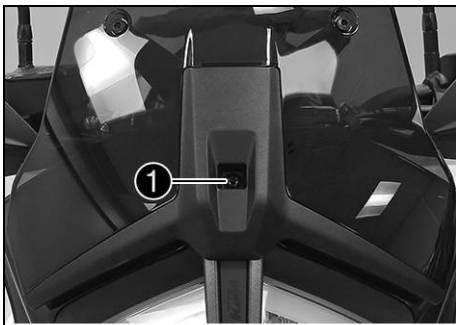

Alternative 1

- Remove screw **1** and windshield **2**.
- Position windshield **2** in lower recess **A**.
- Mount and tighten screw **1**.

Guideline

Remaining screws, chassis	M5	5 Nm (3.7 lbf ft)
---------------------------	----	-------------------

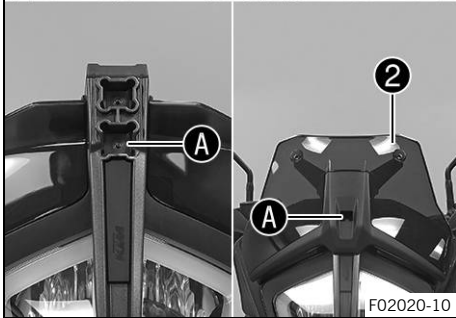

F02020-10



Alternative 2

- Remove screw **1** and windshield **2**.
- Position windshield **2** in upper recess **B**.
- Mount and tighten screw **1**.

Guideline

Remaining screws, chassis	M5	5 Nm (3.7 lbf ft)
---------------------------	----	-------------------

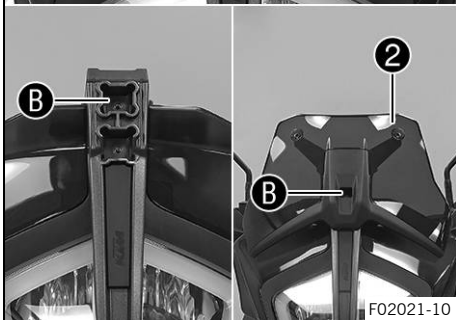

F02021-10

8.4 Adjusting the basic position of the clutch lever

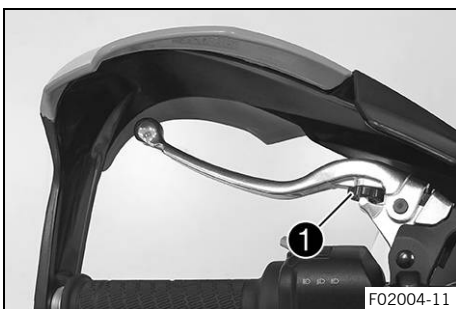

- Push clutch lever forward.
- Adjust the basic position of the clutch lever to your hand size by turning adjusting screw **1**.

F02004-11

i Info

When the adjusting screw is turned clockwise, the clutch lever moves closer to the handlebar. When the adjusting screw is turned counterclockwise, the clutch lever moves away from the handlebar. The range of adjustment is limited. Only turn the adjusting screw by hand, and do not use force. Do not make any adjustments while riding.

8.5 Adjusting the basic position of the hand brake lever



- Push hand brake lever forward.
- Adjust the basic position of the hand brake lever to your hand size by turning adjusting screw ①.

i Info

Turn the adjusting screw clockwise to decrease the distance between the hand brake lever and the handlebar. Turn the adjusting screw counterclockwise to increase the distance between the hand brake lever and the handlebar. The range of adjustment is limited. Only turn the adjusting screw by hand, and do not use force. Do not make any adjustments while riding.

8.6 Adjusting foot brake lever stub

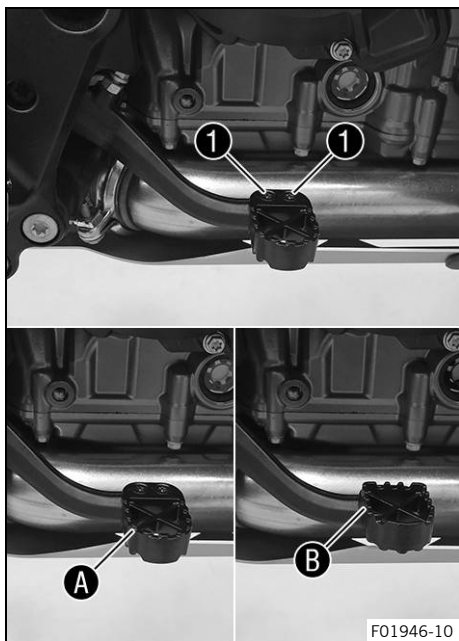

- Remove screws ① with the foot brake lever stub.
- Move the foot brake lever stub into desired position A or B. Mount and tighten screws ①.

Guideline

Screw, foot brake lever stub	M5	10 Nm (7.4 lbf ft) Loctite®243™
------------------------------	----	---

8.7 Adjusting the basic position of the foot brake lever

Warning
Danger of accidents The brake system fails in the event of overheating.
 If there is no free travel on the foot brake lever, pressure builds up in the brake system on the rear brake.
 – Set the free travel on the foot brake lever in accordance with the specification.

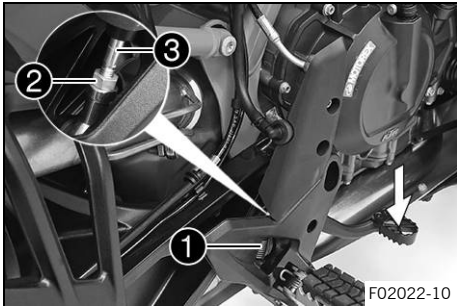

- Detach spring ①.
- Loosen nut ②.

i Tip
 Press the foot brake lever downwards to make this easier.

- Turn the push rod ③ to set the basic position of the foot brake lever.

i Info
 The range of adjustment is limited.
 The screw must be screwed in by at least five full turns.
 Screwing the push rod into the ball joint adjusts the foot brake lever downwards.
 Screwing the push rod out of the ball joint adjusts the brake lever upwards.

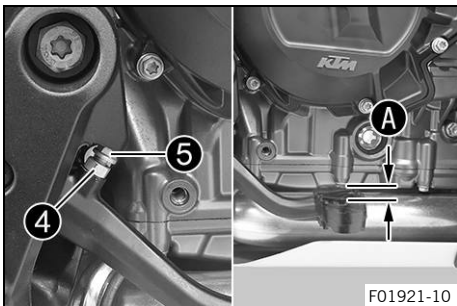

- Loosen nut ④ and turn screw ⑤ correspondingly until the free travel A is present. If necessary, adjust the basic position of the foot brake lever.

Guideline

Free travel at foot brake lever	3 ... 5 mm (0.12 ... 0.2 in)
---------------------------------	------------------------------

- Hold screw ⑤ and tighten nut ④.

Guideline

Nut, foot brake lever adjustment	M6	6 Nm (4.4 lbf ft)
----------------------------------	----	-------------------

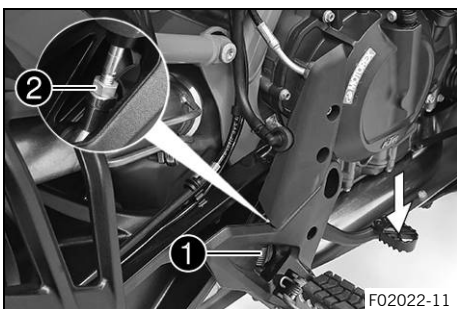

- Tighten nut ②.

Guideline

Nut, push rod, foot brake lever	M6	6 Nm (4.4 lbf ft)
---------------------------------	----	-------------------

i Tip
 Press the foot brake lever downwards to make this easier.

- Attach spring ①.

8.8 Checking the basic position of the shift lever

i Info

When driving, the shift lever must not touch the rider's boot when in the basic position. If the shift lever is permanently touching the boot, the transmission will be subject to excessive load; this can cause a malfunction of the quickshifter + (optional).

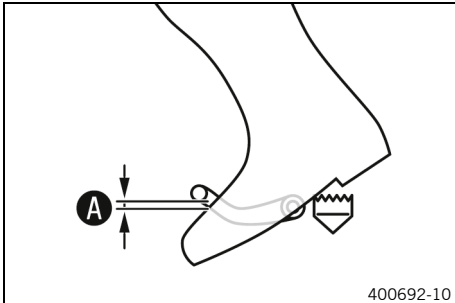

- Sit on the vehicle in the riding position and determine distance **A** between the upper edge of your boot and the shift lever.

Distance between shift lever and upper edge of boot	10 ... 20 mm (0.39 ... 0.79 in)
---	---------------------------------

- » If the distance does not meet specifications:
 - Adjust the basic position of the shift lever. 🛠️ (📖 p. 64)

8.9 Adjusting the basic position of the shift lever 🛠️

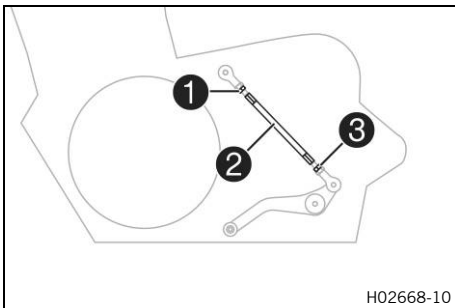

- Loosen nut **1**, holding threaded rod **2**.
- Loosen nut **3**, holding threaded rod **2**.

i Info

Nut **3** has a left-handed thread.

- Turn threaded rod **2** to adjust the shift lever.

i Info

The range of adjustment is limited. The shift lever must not come into contact with any other vehicle components during the shift procedure.

- Tighten nut **3** while holding threaded rod **2**.

Guideline

Nut, shift rod	M6LH	6 Nm (4.4 lbf ft)
----------------	------	-------------------

- Tighten nut **1** while holding threaded rod **2**.

Guideline

Nut, shift rod	M6	6 Nm (4.4 lbf ft)
----------------	----	-------------------

9.1 Advice on preparing for first use



Danger

- Danger of accidents** A rider who is not fit to ride poses a danger to him or herself and others.
- Do not operate the vehicle if you are not fit to ride due to alcohol, drugs or medication.
 - Do not operate the vehicle if you are physically or mentally impaired.



Warning

- Risk of injury** Missing or poor protective clothing presents an increased safety risk.
- Wear appropriate protective clothing such as helmet, boots, gloves as well as trousers and a jacket with protectors on all rides.
 - Always wear protective clothing that is in good condition and meets the legal regulations.



Warning

- Danger of crashing** Different tire tread patterns on the front and rear wheel impair the handling characteristic.
- Different tire tread patterns can make the vehicle significantly more difficult to control.
- Make sure that only tires with a similar tire tread pattern are fitted to the front and rear wheel.



Warning

- Danger of accidents** Non-approved or non-recommended tires and wheels impact the handling characteristic.
- Only use tires/wheels approved by KTM with the corresponding speed index.



Warning

- Danger of accidents** New tires have reduced road grip.
- The contact surface on new tires is not yet roughened.
- Run in new tires with moderate riding at alternating angles.
- | | |
|------------------|-----------------|
| Running-in phase | 200 km (124 mi) |
|------------------|-----------------|



Warning

- Danger of accidents** The brake system fails in the event of overheating.
- If the foot brake lever is not released, the brake linings drag continuously.
- Take your foot off the foot brake lever if you do not want to brake.



Info

When using your vehicle, remember that others may feel disturbed by excessive noise.

- Make sure that the pre-sales inspection work has been carried out by an authorized KTM workshop.
 - ✓ You will receive a delivery certificate when the vehicle is handed over.
- Before riding for the first time, read the entire Owner's Manual carefully.
- Get to know the controls.
- Adjust basic position of the clutch lever. (📖 p. 61)
- Adjust basic position of the hand brake lever. (📖 p. 62)
- Adjust the basic position of the foot brake lever. 🦶 (📖 p. 63)
- Get used to the handling characteristic of the motorcycle in a suitable area before making a longer trip. Try also to ride as slowly as possible to get a better feel for the motorcycle.
- Hold the handlebar firmly with both hands and keep your feet on the footrests when riding.

- Run the engine in. (📖 p. 66)

9.2 Running in the engine

- During the running-in phase, do not exceed the specified engine speed.

Guideline

Maximum engine speed	
During the first: 1,000 km (620 mi)	6,500 rpm
After the first: 1,000 km (620 mi)	9,800 rpm

- Avoid fully opening the throttle!



Info

If the maximum engine speed is exceeded before the first service, the shift warning light flashes.

9.3 Loading the vehicle



Warning

Danger of accidents Total weight and axle loads influence the handling characteristic.

The total weight consists of: motorcycle ready for operation and with a full tank, driver and passenger with protective clothing and helmet, and luggage.

- Do not exceed the maximum permissible overall weight or the axle loads.



Warning

Danger of accidents Improper mounting of cases or the tank rucksack impairs the handling characteristic.

- Mount and secure cases and tank rucksack according to the manufacturer's instructions.



Warning

Danger of accidents Carrying luggage alters handling characteristics at high speed.

- Adapt your speed to your payload.
 - Ride more slowly if your motorcycle is loaded with cases or other luggage.
- | | |
|----------------------------|---------------------|
| Maximum speed with luggage | 150 km/h (93.2 mph) |
|----------------------------|---------------------|



Warning

Danger of accidents The luggage system will be damaged if it is overloaded.

- Read the manufacturer information on maximum payload when mounting cases.



Warning

Danger of accidents Luggage which has slipped impairs visibility.

If the tail light is covered, you are less visible to traffic behind you, especially when it is dark.

- Check that your luggage is fixed properly at regular intervals.



Warning

Danger of accidents A high payload alters the handling characteristic and increases the stopping distance.

- Adapt your speed to your payload.



Warning

Danger of accidents Pieces of luggage which have slipped impair the handling characteristic.

- Check that your luggage is fixed properly at regular intervals.



Warning

Fire hazard The hot exhaust system may burn luggage.

- Fasten your luggage in such a way that it cannot be burned or singed by the hot exhaust system.

- If you carry luggage, make sure you secure it firmly as close as possible to the center of the vehicle and ensure even weight distribution between the front and rear wheels.
- Do not exceed the maximum permissible weight and the maximum permissible axle loads.

Guideline

Maximum permissible total weight	450 kg (992 lb.)
Maximum permissible front axle load	175 kg (386 lb.)
Maximum permissible rear axle load	275 kg (606 lb.)



10.1 Checks and maintenance measures when preparing for use

i Info

Before every trip, check the condition of the vehicle and ensure that it is roadworthy. The vehicle must be in perfect technical condition when it is being operated.

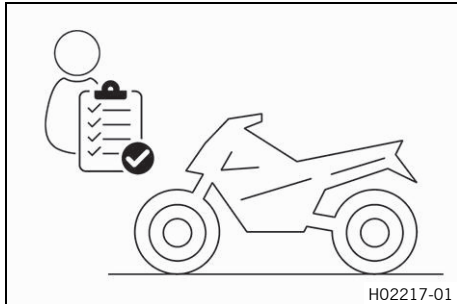

- Check the engine oil level. (📖 p. 141)
- Check the front brake fluid level. (📖 p. 110)
- Check the rear brake fluid level. (📖 p. 112)
- Check the front brake linings. (📖 p. 111)
- Check the rear brake linings. (📖 p. 114)
- Check that the brake system is functioning properly.
- Check the coolant level in the compensating tank. (📖 p. 136)
- Check the chain for dirt. (📖 p. 88)
- Check the chain tension. (📖 p. 89)
- Check the tire condition. (📖 p. 121)
- Check tire pressure. (📖 p. 122)
- Check the settings of all controls and ensure that they can be operated smoothly.
- Check that the electrical system is functioning properly.
- Check that luggage is properly secured.
- Sit on the motorcycle and check the rear mirror setting.
- Check the fuel level.

10.2 Starting the vehicle



Danger

Danger of poisoning Exhaust gases are toxic and inhaling them may result in unconsciousness and death.

- Always make sure there is sufficient ventilation when running the engine.
- Use effective exhaust extraction when starting or running the engine in an enclosed space.

Note

Engine damage High revving speed with a cold engine negatively impacts the lifespan of the engine.

- Always run the engine warm at a low speed.

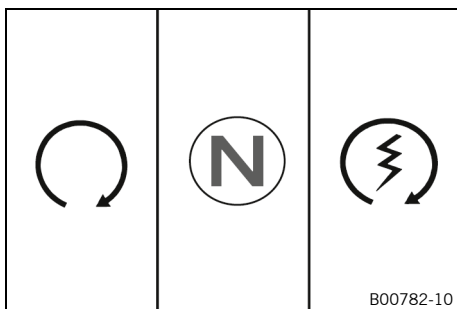

- Take the motorcycle off the side stand and sit on the motorcycle.
- Make sure that the start button/emergency OFF switch is in the middle position ○.
- Switch on the ignition by turning the ignition key to the position ○.

Guideline

To avoid malfunctions in the control unit communication, do not switch the ignition off and on in rapid succession.

- ✓ After you switch on the ignition, you can hear the fuel pump working for about two seconds. The function check of the combination instrument is run at the same time.

- ✓ The ABS warning lamp lights up and goes back out after starting off.
- Shift the transmission into neutral **N**.
- ✓ The green idle indicator lamp **N** lights up.
- Press the start button/emergency OFF switch into the lower position $\text{\textcircled{3}}$.

i Info

Only press the start button/emergency OFF switch into the lower position $\text{\textcircled{3}}$ when the combination instrument function check has been completed.
Do not open the throttle to start.
Press the start button/emergency OFF switch into the lower position $\text{\textcircled{3}}$ for a maximum of five seconds. Wait for at least 5 seconds before trying again.
This motorcycle is equipped with a safety starting system. You can only start the engine if the transmission is in neutral or if the clutch lever is pulled when a gear is engaged. If the side stand is folded out and you shift into gear and release the clutch lever, the engine stops.



10.3 Starting off

- Pull the clutch lever, engage 1st gear, release the clutch lever slowly and simultaneously open the throttle carefully.



10.4 Quickshifter + (optional)

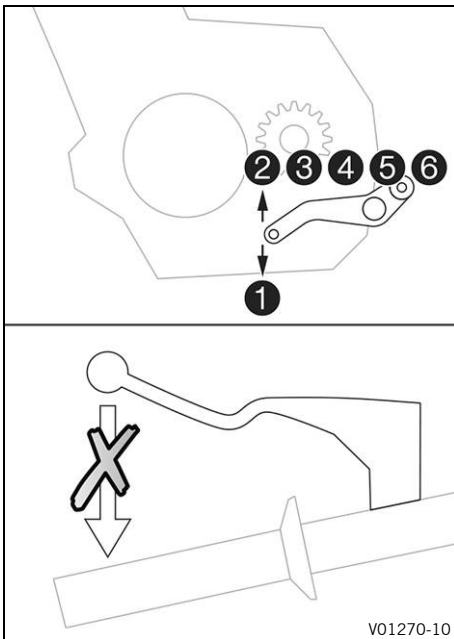

If the quickshifter + is activated, you can shift up and down without actuating the clutch.
Because there is no need to close the throttle grip, uninterrupted gear shifts are possible.
The quickshifter + uses the shifter shaft position to check whether or not a shift should be initiated, and sends a corresponding signal to the engine control.
If the quickshifter + is disabled in the combination instrument, the clutch needs to be actuated in the normal way for each shift.

10.5 Shifting, riding



Warning

Danger of accidents Abrupt load alterations can cause the vehicle to get out of control.

- Avoid abrupt load alterations and sudden braking actions.
- Adapt your speed to the road conditions.



Warning

Danger of accidents If you change down at high engine speed, the rear wheel blocks and the engine races.

- Do not change into a low gear at high engine speed.



Warning

Danger of accidents An incorrect ignition key position causes malfunctions.

- Do not change the ignition key position while driving.



Warning

Danger of accidents Adjustments to the vehicle distract attention from traffic activity.

- Make all adjustments when the vehicle is at a standstill.



Warning

Risk of injury The passenger may fall from the motorcycle if they conduct themselves incorrectly.

- Ensure that the passenger sits correctly on the passenger seat, places his or her feet on the passenger foot pegs and holds on to the rider or the grab handles.
- Note the regulations governing the minimum age of passengers in your country.



Warning

Danger of accidents A risky riding style constitutes a major risk.

- Comply with traffic regulations and ride defensively and with foresight to detect sources of danger as early as possible.



Warning

Danger of accidents Cold tires have reduced road grip.

- Ride the first miles carefully on every journey at moderate speed until the tires reach operating temperature.



Warning

Danger of accidents New tires have reduced road grip.

The contact surface on new tires is not yet roughened.

- Run in new tires with moderate riding at alternating angles.
Running-in phase 200 km (124 mi)



Warning

Danger of accidents Total weight and axle loads influence the handling characteristic.

The total weight consists of: motorcycle ready for operation and with a full tank, driver and passenger with protective clothing and helmet, and luggage.

- Do not exceed the maximum permissible overall weight or the axle loads.



Warning

- Danger of accidents** Pieces of luggage which have slipped impair the handling characteristic.
- Check that your luggage is fixed properly at regular intervals.



Warning

- Danger of accidents** A fall can damage the vehicle more seriously than it may first appear.
- Check the vehicle after a fall as you do when preparing for use.

Note

Engine damage Unfiltered intake air has a negative effect on the service life of the engine. Dust and dirt will enter the engine without an air filter.

- Only operate the vehicle if it is equipped with an air filter.

Note

Engine failure Overheating damages the engine.

- If the coolant temperature warning is displayed, stop immediately and take care not to endanger yourself or other traffic participants in the process.
- Allow the engine and cooling system to cool down.
- Check and, if necessary, correct the coolant level on the cooling system while it is in a cooled state.

Note

Transmission damage Incorrect use of Easy Shift will damage the transmission.

Easy Shift can only be used if the function is activated in the combination instrument. Easy Shift is not active if you pull the clutch lever.

- Only use Easy Shift in the permitted speed range shown.



Info

If unusual noises occur while riding, stop immediately (taking care not to endanger yourself or other road users in the process), switch off the engine and contact an authorized KTM workshop.

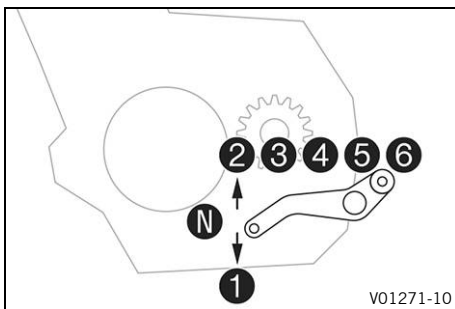

- Shift into a higher gear when conditions allow (incline, road situation, etc.).
- Release the throttle while simultaneously pulling the clutch lever, shift into the next gear, release the clutch lever, and open the throttle.



Info

You can see the positions of the 6 forward gears in the figure. The neutral or idle position is between the first and second gears. First gear is used for starting off or for steep inclines.

The operating temperature is reached when 5 bars of the temperature indicator light up.

- After reaching maximum speed by fully opening the throttle grip, turn the throttle back so it is $\frac{3}{4}$ open. This will barely reduce the speed, but fuel consumption will be considerably lower.
- Only accelerate up to a speed suitable for the road surface and weather conditions. Particularly in bends, do not shift, and accelerate very carefully.
- Brake if necessary and close the throttle at the same time in order to shift down.

- Pull clutch lever and shift into a lower gear, release the clutch lever slowly, and open the throttle or shift again.
- If the engine stalls (e.g., at a crossroads), just pull clutch lever and press the start button/emergency OFF switch into the lower position (3). The transmission must not be shifted into neutral.
- Switch off the engine if running at idle speed or stationary for a long time.
- If the oil pressure warning lamp (oil can icon) lights up during a trip, stop immediately and switch off the engine. Contact an authorized KTM workshop.
- If the malfunction indicator lamp (MIL icon) lights up during a trip, please contact an authorized KTM workshop as soon as possible.
- If the general warning lamp (triangle icon) lights up during a trip, the display shows a message.

i Info

Very important messages are stored in the **Warning** menu.

- If the ice warning appears in the combination instrument, the roads may be icy. Adjust your speed to the road conditions.
- If the quickshifter + (optional) is enabled in the combination instrument, you can shift up in the speed range shown without pulling the clutch lever.

i Info

The minimum engine speed before shifting up in revolutions per minute is shown in the figure. Pull the shift lever quickly back to the stop without changing the throttle twist grip position.

- If the quickshifter + (optional) is enabled in the combination instrument, you can shift down in the speed range shown without pulling the clutch lever.

i Info

The maximum engine speed before shifting down in revolutions per minute is shown in the figure. Depress the shift lever quickly back to the stop without changing the throttle twist grip position.

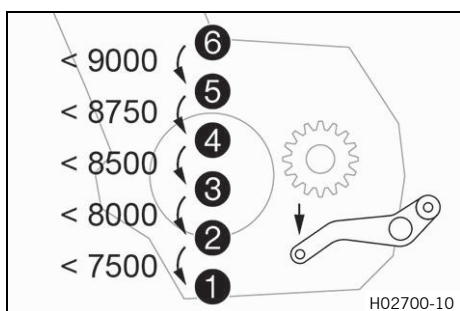
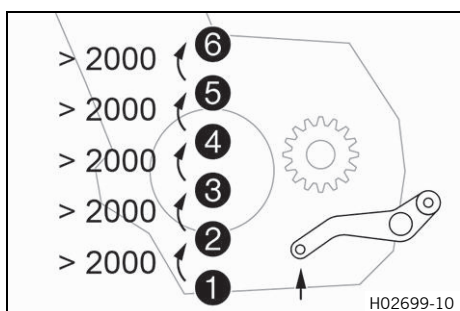

10.6 MSR (optional)

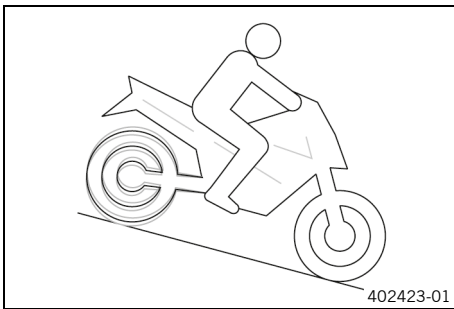

The **MSR** is an optional auxiliary function of the engine control. If the engine braking effect is too great, the **MSR** prevents the rear wheel from locking or sliding away on a sloping position. To avoid slip of the rear wheel, the **MSR** only opens the throttle valve as far as absolutely necessary. The **MSR** is applied on surfaces, where the friction coefficient is too low to open the slipper clutch. To further increase ride safety, the **MSR** is slope dependent.



Info

When ABS mode **Offroad** is active, the **MSR** is not active.

10.7 Applying the brakes



Warning

Danger of accidents Moisture and dirt impair the brake system.

- Brake carefully several times to dry out and remove dirt from the brake linings and the brake discs.



Warning

Danger of accidents A spongy pressure point on the front or rear brake reduces braking efficiency.

- Check the brake system and do not continue riding until the problem is eliminated. (Your authorized KTM workshop will be glad to help.)



Warning

Danger of accidents The brake system fails in the event of overheating.

If the foot brake lever is not released, the brake linings drag continuously.

- Take your foot off the foot brake lever if you do not want to brake.



Warning

Danger of accidents Higher total weight increases the stopping distance.

- Take the longer stopping distance into account when carrying a passenger or luggage with you.



Warning

Danger of accidents Salt on the roads impairs the brake system.

- Brake carefully several times to remove salt from the brake linings and the brake discs.



Warning

Danger of accidents ABS may increase the stopping distance in certain situations.

- Adjust application of the brakes to the respective riding situation and riding surface conditions.



Warning

Danger of accidents Excessively forceful application of the brakes blocks the wheels.

The ABS effectiveness is only ensured if it is switched on.

- Leave the ABS switched on in order to benefit from the protective effect.



Warning

Danger of accidents The rear wheel can lock due to the engine braking effect.

- Pull in the clutch, if you perform emergency or full braking, or if you brake on a slippery ground.



Warning

Danger of accidents Driving aids can reduce the probability of a fall only within physical limits.

It is not always possible to compensate for extreme riding situations, for example with luggage loaded with a high center of gravity, varying road surfaces, steep descents or full braking without disengaging the gear.

- Adapt your riding style to the road conditions and your driving ability.

- When braking, release the throttle and apply the front and rear brakes at the same time.



Info

When the ABS is enabled, maximum braking power can be achieved even with low road grip surfaces such as sandy, wet, or slippery terrain without locking the wheels.



Warning

Danger of accidents Banked or laterally sloping ground reduces the maximum possible delay.

- If possible finish braking before going into a bend.

- Always finish the braking before you go into a bend. Shift down to a lower gear appropriate to your speed.
- Use the braking effect of the engine on long downhill stretches. To do so, shift back one or two gears, but do not overrev the engine. This means that significantly less braking is required and the brake system does not overheat.

10.8 Stopping, parking



Warning

Risk of injury People who act without authorization endanger themselves and others.

- Do not leave the vehicle unattended if the engine is running.
- Protect the vehicle against access by unauthorized persons.
- Lock the steering and remove the ignition key if you leave the vehicle unattended.



Warning

Danger of burns Some vehicle components become very hot when the vehicle is operated.

- Do not touch any parts such as the exhaust system, radiator, engine, shock absorber, or brake system before the vehicle parts have cooled down.
- Let the vehicle parts cool down before you perform any work on the vehicle.

Note

Material damage The vehicle may be damaged by incorrect procedure when parking.

Significant damage may be caused if the vehicle rolls away or falls over.

The components for parking the vehicle are designed only for the weight of the vehicle.

- Park the vehicle on a firm and level surface.
- Ensure that nobody sits on the vehicle when the vehicle is parked on a stand.

Note

Fire hazard Hot vehicle components pose a fire hazard and explosion risk.

- Do not park the vehicle near to materials which are highly flammable or explosive.
- Allow the vehicle to cool down before covering it.

- Apply the brakes on the motorcycle.
- Shift the transmission into neutral

- Switch off the ignition by turning the ignition key to the position ☒.

i Info

If the engine is switched off with the emergency OFF switch and the ignition remains switched on at the ignition lock, power continues to flow to most electrical power consumers. This discharges the 12-V battery. You should therefore always switch off the engine with the ignition lock – the emergency OFF switch is intended for emergencies only.

- Park the motorcycle on a firm surface.
- Swing side stand forward with your foot as far as it will go and lean the vehicle on it.
- Lock the steering by turning the handlebar fully to the left, pressing down the ignition key to the position ☒ and turning it to the position ☐. To make the steering lock engage more easily, move the handlebar a little to the left and right. Remove the ignition key.



10.9 Transporting

Note

Danger of damage The parked vehicle can roll away or fall over.

- Park the vehicle on a firm and level surface.

Note

Fire hazard Hot vehicle components pose a fire hazard and explosion risk.

- Do not park the vehicle near to materials which are highly flammable or explosive.
- Allow the vehicle to cool down before covering it.

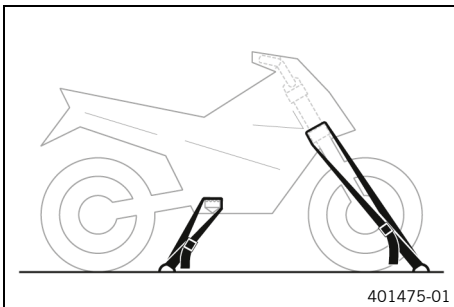

- Switch off the engine.
- Use tension belts or other suitable devices to secure the motorcycle against falling over or rolling away.

10.10 Towing in the event of a breakdown

Note

Danger of damage Towing away using a towing vehicle is not an appropriate vehicle recovery method.

Damage to the drive train or transmission may occur during towing.

- Do not use towing equipment where the wheels of the broken down vehicle remain on the road and rotate as it is towed.
- Always transport a broken down vehicle on a trailer or on the loading area of a transport vehicle.

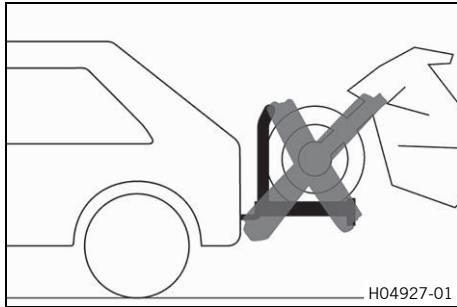

- Ensure that the broken down vehicle is properly secured on the trailer or transport vehicle.
- Observe local regulations for the recovery of broken down vehicles.

10.11 Refueling



Danger

Fire hazard Fuel is highly flammable.

The fuel in the fuel tank expands when warm and can escape if overfilled.

- Do not fuel the vehicle in the vicinity of open flames or lit cigarettes.
- Switch off the engine for refueling.
- Make sure that no fuel is spilled; particularly not on hot parts of the vehicle.
- If any fuel is spilled, wipe it off immediately.
- Observe the specifications for refueling.



Warning

Danger of poisoning Fuel is poisonous and a health hazard.

- Avoid skin, eye and clothing contact with fuel.
- Immediately consult a doctor if you swallow fuel.
- Do not inhale fuel vapors.
- In case of skin contact, rinse the affected area with plenty of water.
- Rinse the eyes thoroughly with water, and consult a doctor in case of fuel contact with the eyes.
- Change your clothing in case of fuel spills on them.

Note

Material damage Inadequate fuel quality causes the fuel filter to quickly become clogged.

In some countries and regions, the available fuel quality and cleanliness may not be sufficient. This will result in problems with the fuel system.

- Refuel only with clean fuel that meets the specified standards. (Your authorized KTM workshop will be glad to help.)



Note

Environmental hazard Improper handling of fuel is a danger to the environment.

- Do not allow fuel to enter the groundwater, the soil, or the sewage system.

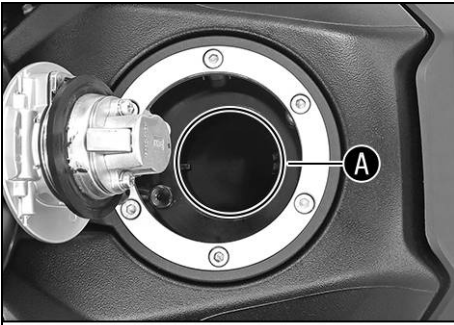

- Switch off the engine.
- Open the fuel tank filler cap. (📖 p. 21)
- Fill the fuel tank with fuel up to the lower edge **A** of the filler neck.

Total fuel tank capacity, approx.	20 l (5.3 US gal)	Super unleaded (ROZ 95) (📖 p. 164)
-----------------------------------	----------------------	--

- Close the fuel tank filler cap. (📖 p. 22)



F03291-10

















11.1 Additional information

Any further work that results from the compulsory work or from the recommended work must be ordered separately and invoiced separately.

Different service intervals may apply in your country, depending on the local operating conditions.

Individual service intervals and scopes may change in the course of technical developments. The most up-to-date service schedule can always be found on KTM Dealer.net. Your authorized KTM dealer will be happy to advise you.

11.2 Required work

	every 24 months	every 12 months	every 30,000 km (18,600 mi)	every 15,000 km (9,300 mi)	after 1,000 km (620 mi)
Read out the trouble code memory using the KTM diagnostics tool. 	○	●	●	●	●
Program the shift shaft sensor. 	○	●	●	●	●
Check that the electrical system is functioning properly.	○	●	●	●	●
Change the engine oil and the oil filter, clean the oil screens.  (📖 p. 141)	○	●	●	●	●
Check the front brake linings. (📖 p. 111)	○	●	●	●	●
Check the rear brake linings. (📖 p. 114)	○	●	●	●	●
Check brake discs. (📖 p. 109)	○	●	●	●	●
Check the brake lines for damage and leakage. 	○	●	●	●	●
Check the front brake fluid level. (📖 p. 110)	○	●	●	●	●
Check the rear brake fluid level. (📖 p. 112)	○	●	●	●	●
Change the front brake fluid. 					●
Change the rear brake fluid. 					●
Check the free travel of the clutch lever. (📖 p. 144)	○	●	●	●	●
Check the free travel of the foot brake lever. (📖 p. 112)	○	●	●	●	●
Check the shock absorber and fork for leaks. Perform service as needed and depending on how the vehicle is used. 	○	●	●	●	●
Clean the dust boots of the fork legs.  (📖 p. 100)		●	●		
Check the steering head bearing for play. 	○	●	●	●	●
Check the tire condition. (📖 p. 121)	○	●	●	●	●
Check tire pressure. (📖 p. 122)	○	●	●	●	●
Retighten the spokes. 	○				
Check the spoke tension. (📖 p. 122)		●	●	●	●
Check the rim run-out. 	○	●	●	●	●
Check the chain, rear sprocket, engine sprocket, and chain guide. (📖 p. 90)		●	●	●	●
Check the chain tension. (📖 p. 89)	○	●	●	●	●
Change the spark plugs. 				●	
Check the valve clearance. 				●	
Check the coolant fill level and antifreeze. 	○	●	●	●	●
Check the cables for damage and for routing without kinks. 		●	●	●	●
Change the air filter, clean the air filter box. 		●	●		
Check the fuel pressure. 		●	●	●	●
Check the headlight setting. (📖 p. 133)	○	●	●		

	every 24 months				
	every 12 months				
	every 30,000 km (18,600 mi)				
	every 15,000 km (9,300 mi)				
	after 1,000 km (620 mi)				
Check that the radiator fan is functioning properly. 🛠️	○	●	●	●	●
Final check: Check the vehicle is roadworthy and take a test ride. 🛠️	○	●	●	●	●
Read out the error memory after the test ride using the KTM diagnostics tool. 🛠️	○	●	●	●	●
Set the service interval display. 🛠️	○	●	●	●	●
Make a service entry in KTM Dealer.net . 🛠️	○	●	●	●	●

- One-time interval
- Periodic interval

11.3 Recommended work

	every 48 months				
	every 12 months				
	every 30,000 km (18,600 mi)				
	every 15,000 km (9,300 mi)				
	after 1,000 km (620 mi)				
Check the frame. 🛠️				●	
Check the link fork. 🛠️				●	
Check/clean the oil nozzle for clutch lubrication. 🛠️	○	●	●		
Check the fork bearing for play. 🛠️		●	●		
Check the wheel bearing for play. 🛠️		●	●		
Change the coolant. 🛠️					●
Empty the drainage hoses. 🛠️	○	●	●	●	●
Check all hoses (e.g. fuel, cooling, bleeder, drainage, etc.) and sleeves for cracking, leaks, and incorrect routing. 🛠️		●	●	●	●
Grease all moving parts (e.g., side stand, hand lever, chain, ...) and check for smooth operation. 🛠️	○	●	●	●	●
Check the tightness of the safety-relevant screws and nuts which are easily accessible. 🛠️	○	●	●	●	●

- One-time interval
- Periodic interval

12.1 Fork/shock absorber

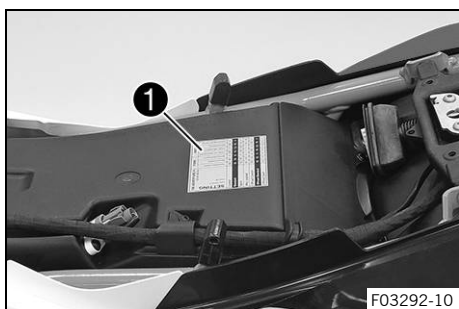

The fork and the shock absorber offer many options of adapting the suspension to the riding style and the payload.

i Info

The recommendations for the suspension setting are shown in table 1. The table is located under the seat on the air filter box.

These adjustments are guidelines and should always be the basis for a suspension setting. If the guidelines are not adhered to, the riding characteristics could deteriorate, particularly at high speeds.

12.2 Adjusting the compression damping of the fork

i Info

The hydraulic compression damping determines the fork suspension behavior.



- Turn white adjuster 1 clockwise as far as it will go.

i Info

Adjuster 1 is located at the upper end of the left fork leg. The compression damping is located in left fork leg **COMP** (white adjuster). The rebound damping is located in right fork leg **REB** (red adjuster).

- Turn counterclockwise by the number of clicks corresponding to the fork type.

Guideline

Compression damping	
Comfort	20 clicks
Standard	15 clicks
Sport	10 clicks
Full payload	15 clicks

i Info

Turn clockwise to increase damping; turn counterclockwise to reduce damping during compression.

12.3 Adjusting the rebound damping of the fork

i **Info**

The hydraulic rebound damping determines the fork suspension behavior.

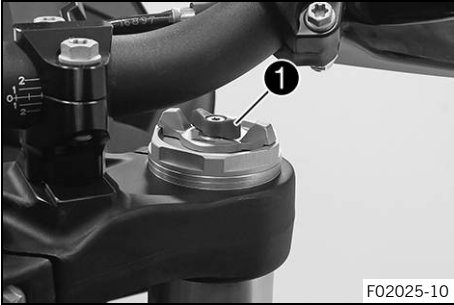

- Turn red adjuster **1** clockwise as far as it will go.

i **Info**

Adjuster **1** is located at the upper end of the right fork leg.
The rebound damping is located in right fork leg **REB** (red adjuster). The compression damping is located in left fork leg **COMP** (white adjuster).

- Turn counterclockwise by the number of clicks corresponding to the fork type.

Guideline

Rebound damping	
Comfort	18 clicks
Standard	15 clicks
Sport	10 clicks
Full payload	15 clicks

i **Info**

Turn clockwise to increase the damping; turn counterclockwise to reduce damping when the shock absorber rebounds.



12.4 Adjusting the spring preload of the fork

Preparatory work

- Raise motorcycle with rear lifting gear. (📖 p. 86)
- Remove the front fender. (📖 p. 99)
- Lift the motorcycle with the front lifting gear. (📖 p. 86)

Main work

- Turn T-grips **1** counterclockwise all the way.
- ✓ Marking **+0** aligns with the right-hand part of the grip.

i **Info**

Make the adjustment by hand only. Do not use a tool.
Make the same adjustment on both fork legs.

- Turn the T-grips clockwise.

Guideline

Spring preload - Preload Adjuster	
Comfort	+0
Standard	+0
Sport	+0
Full payload	+3

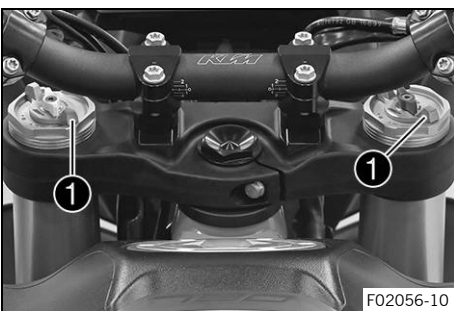

✓ The T-grips engage noticeably at the numerical values.



Info

Adjust the spring preload to the numerical values only as the preload will not engage between the numerical values.

Turn clockwise to increase the spring preload; turn counterclockwise to reduce the spring preload.

Adjusting the spring preload has no influence on the absorption setting of the rebound.

Basically, however, you should set the rebound damping higher with a higher spring preload.

Finishing work

- Take the motorcycle off the front lifting gear. (📖 p. 87)
- Install the front fender. (📖 p. 99)
- Remove the rear of the motorcycle from the lifting gear. (📖 p. 86)

12.5 Compression damping of the shock absorber

The compression damping of the shock absorber is divided into two ranges: high-speed and low-speed. High-speed and low-speed refer to the compression speed of the rear wheel suspension and not to the vehicle speed.

The high-speed compression adjuster, for example, has an effect when riding over an asphalt edge: the rear wheel suspension compresses quickly.

The low-speed compression adjuster has an effect, for example, when riding over long ground swells: the rear wheel suspension compresses slowly.

These two ranges can be adjusted separately, although the transition between high-speed and low-speed is gradual. Thus, modifications in the high-speed range affect the compression damping in the low-speed range and vice versa.

12.6 Adjusting the low-speed compression damping of the shock absorber



Caution

Risk of injury Parts of the shock absorber will move around if the shock absorber is detached incorrectly. The shock absorber is filled with highly compressed nitrogen.

- Please follow the description provided. (Your authorized KTM workshop will be glad to help.)



Info

The effect of the low-speed compression adjuster can be seen in slow to normal compression of the shock absorber.

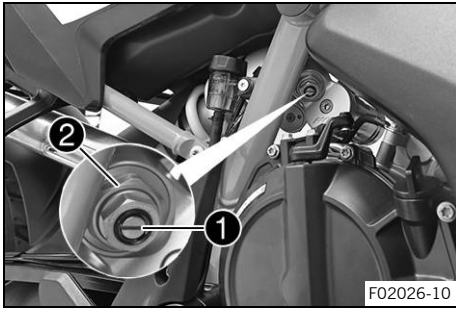

- Turn adjusting screw **1** clockwise with a screwdriver as far as the last perceptible click.

i Info
Do not loosen fitting **2**!

- Turn counterclockwise by the number of clicks corresponding to the shock absorber type.

Guideline

Low-speed compression damping	
Comfort	20 clicks
Standard	15 clicks
Sport	10 clicks
Full payload	7 clicks

i Info
Turn clockwise to increase damping; turn counterclockwise to reduce damping.



12.7 Adjusting the high-speed compression damping of the shock absorber



Caution

Risk of injury Parts of the shock absorber will move around if the shock absorber is detached incorrectly. The shock absorber is filled with highly compressed nitrogen.

- Please follow the description provided. (Your authorized KTM workshop will be glad to help.)



Info

The effect of the high speed compression adjuster can be seen in the fast compression of the shock absorber.

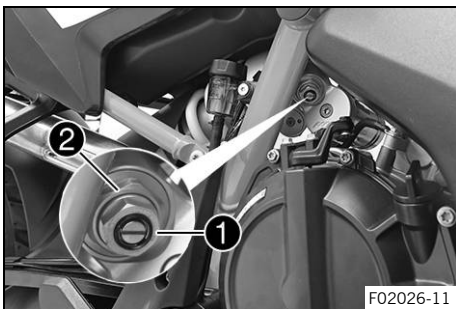

- Turn adjusting screw **1** all the way clockwise with a socket wrench.

i Info
Do not loosen fitting **2**!

- Turn counterclockwise by the number of turns corresponding to the shock absorber type.

Guideline

High-speed compression damping	
Comfort	2 turns
Standard	1.5 turns
Sport	1 turn
Full payload	0.5 turns

i Info
Turn clockwise to increase damping; turn counterclockwise to reduce damping.



12.8 Adjusting the rebound damping of the shock absorber



Caution

Risk of injury Parts of the shock absorber will move around if the shock absorber is detached incorrectly. The shock absorber is filled with highly compressed nitrogen.

- Please follow the description provided. (Your authorized KTM workshop will be glad to help.)

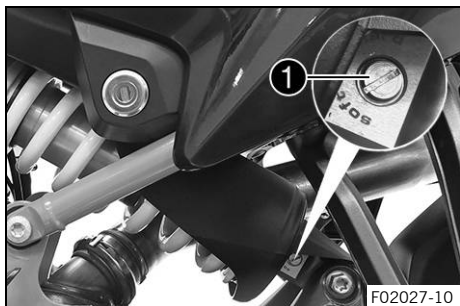

- Turn adjusting screw ❶ clockwise up to the last perceptible click.
- Turn counterclockwise by the number of clicks corresponding to the shock absorber type.

Guideline

Rebound damping	
Comfort	23 clicks
Standard	15 clicks
Sport	12 clicks
Full payload	5 clicks



Info

Turn clockwise to increase the damping; turn counterclockwise to reduce damping when the shock absorber rebounds.

12.9 Adjusting the spring preload of the shock absorber ↴



Warning

Danger of accidents Modifications to the suspension setting may seriously alter the handling characteristic.

- Ride slowly to start with after making adjustments to get the feel of the new handling characteristic.



Info

The spring preload defines the initial status of the spring operation on the shock absorber. The best spring preload setting is achieved when it is set for the weight of the rider and that of any luggage and a passenger, thus ensuring an ideal compromise between handling and stability.

Preparatory work

Condition

- The link fork is relieved of weight.

Main work

- Turn adjusting screw ❶ counterclockwise all the way.
- Turn it clockwise by the number of turns corresponding to the shock absorber type and use.

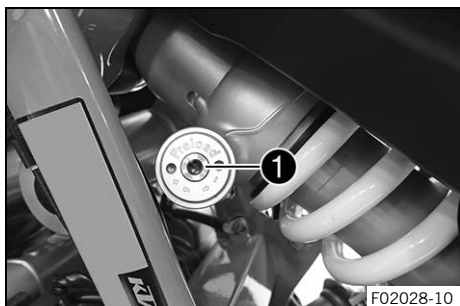

Guideline

Spring preload - Preload Adjuster	
Comfort	4 turns
Standard	4 turns
Sport	4 turns
Full payload	10 turns

**Info**

Turn clockwise to increase the spring preload; turn counterclockwise to reduce the spring preload.



13.1 Raising the motorcycle with rear lifting gear

Note

Danger of damage The parked vehicle can roll away or fall over.

- Park the vehicle on a firm and level surface.

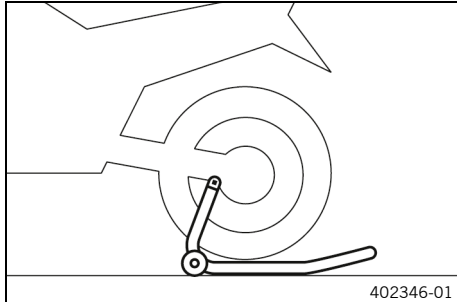

- Mount retaining adapter on the link fork.
- Insert adapter in the rear lifting gear.

Retaining adapter (61029955144)

Rear wheel work stand (69329955000)

- Stand motorcycle upright, align lifting gear to the link fork with the adapters, and raise motorcycle.

13.2 Removing the rear of the motorcycle from the lifting gear

Note

Danger of damage The parked vehicle can roll away or fall over.

- Park the vehicle on a firm and level surface.

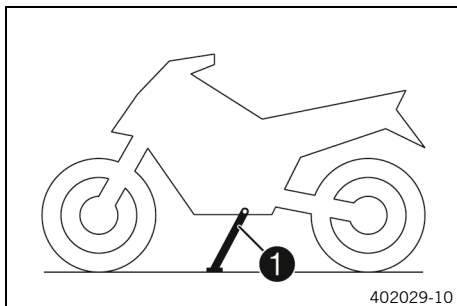

- Secure the motorcycle against falling over.
- Remove the rear lifting gear and lean the vehicle on side stand ①.
- Remove the retaining adapter from the link fork.

13.3 Lifting the motorcycle with the front lifting gear

Note

Danger of damage The parked vehicle can roll away or fall over.

- Park the vehicle on a firm and level surface.

Preparatory work

- Raise motorcycle with rear lifting gear. (📖 p. 86)
- Remove the front fender. (📖 p. 99)

Main work

- Move the handlebar to the straight-ahead position.
- Attach the front lifting gear with the adapters on the steering stem.

Mounting pin (69329965040)

Front wheel work stand, large (69329965100)

- Align the front lifting gear with the fork legs.

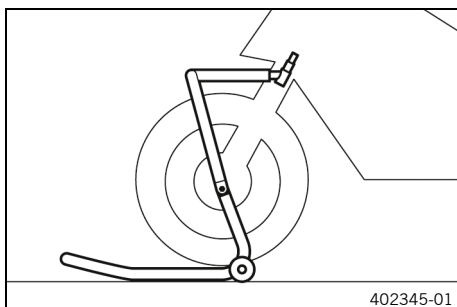

i Info
Always raise the motorcycle at the rear first.

- Lift the motorcycle at the front.



13.4 Taking the motorcycle off the front lifting gear

Note

Danger of damage The parked vehicle can roll away or fall over.

- Park the vehicle on a firm and level surface.

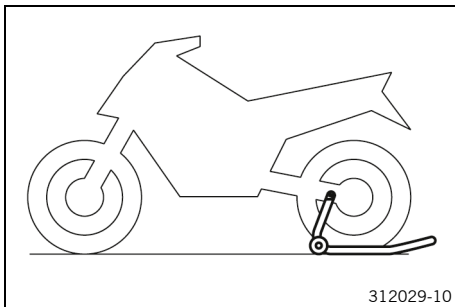

Main work

- Secure the motorcycle against falling over.
- Remove the front lifting gear.

Finishing work

- Install the front fender. (📖 p. 99)



13.5 Removing the seat

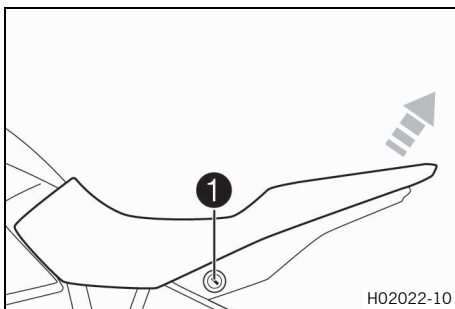

- Insert the ignition key in seat lock **1** and turn it clockwise.
- Raise the rear of the seat, pull the seat back, and lift it off.
- Remove the ignition key.



13.6 Mounting the seat

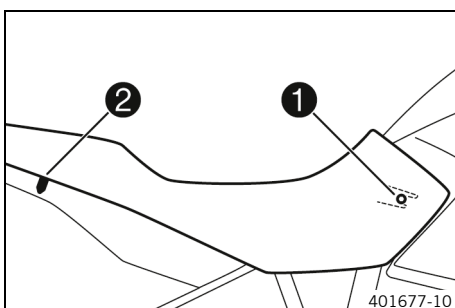

- Hook holding lug **1** of the seat onto the fuel tank, lower the rear and push it forward.
- Insert locking pin **2** into the lock housing and push down the rear of the seat until the locking pin engages with a click.
- Check that the seat is correctly mounted.



13.7 Checking for chain dirt

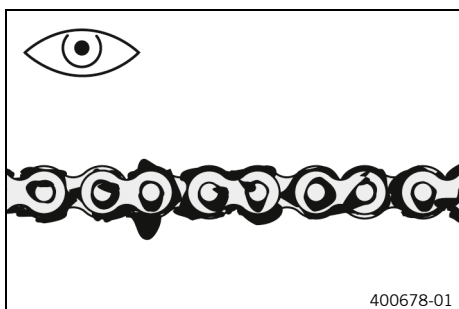

- Check the chain for coarse dirt accumulation.
 - » If the chain is very dirty:
 - Clean the chain. (📖 p. 88)

13.8 Cleaning the chain



Warning

Danger of accidents Lubricants on the tires reduces the road grip.

- Remove lubricants from the tires using a suitable cleaning agent.



Warning

Danger of accidents Oil or grease on the brake discs reduces the braking effect.

- Always keep the brake discs free of oil and grease.
- Clean the brake discs with brake cleaner when necessary.



Note

Environmental hazard Hazardous substances cause environmental damage.

- Dispose of oils, grease, filters, fuel, cleaning agents, brake fluid, etc., correctly and in compliance with the applicable regulations.



Info

The service life of the chain depends largely on its maintenance.

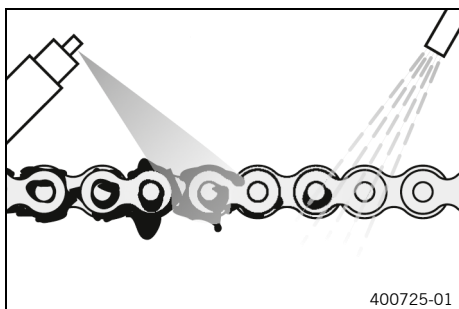

Preparatory work

- Raise motorcycle with rear lifting gear. (📖 p. 86)

Main work

- Rinse off loose dirt with a soft jet of water.
- Remove old grease residue with chain cleaner.

Chain cleaner (📖 p. 165)

- After drying, apply chain spray.

Street chain spray (📖 p. 165)

Finishing work

- Remove the rear of the motorcycle from the lifting gear. (📖 p. 86)

13.9 Checking the chain tension



Warning

Danger of accidents Incorrect chain tension damages components and results in accidents.

If the chain is tensioned too much, the chain, engine sprocket, rear sprocket, transmission and rear wheel bearings wear more quickly. Some components may break if overloaded.

If the chain is too loose, the chain may fall off the engine sprocket or the rear sprocket. As a result, the rear wheel locks or the engine will be damaged.

- Check the chain tension regularly.
- Set the chain tension in accordance with the specification.

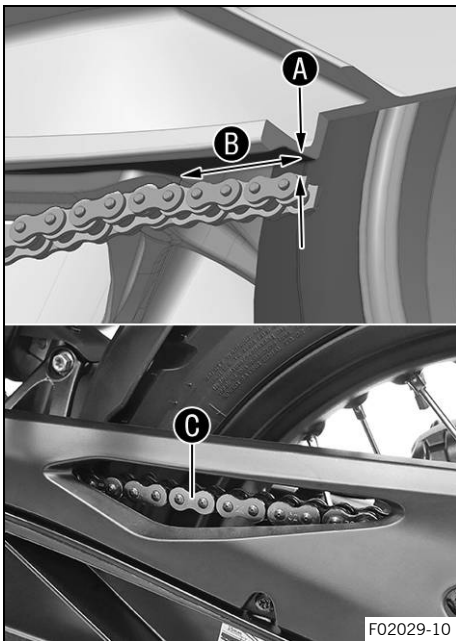

Preparatory work

- Raise motorcycle with rear lifting gear. (📖 p. 86)

Main work

- Shift the transmission into neutral **N**.
- Push the chain behind the chain sliding piece up and determine the chain tension **A** between the link fork and the upper edge of the chain.

Guideline

Distance B from the chain sliding piece	2.5 cm (0.98 in)
Measure the distance from the flat part of the link fork directly above the chain, not from the edge of the link fork.	

i Info

Top chain section **C** must be taut. Chain wear is not always even. Repeat this measurement at different chain positions.

Chain tension	2 ... 5 mm (0.08 ... 0.2 in)
---------------	------------------------------

- » If the chain tension does not meet the specification:
 - Adjust the chain tension. (📖 p. 89)
- Remove the rear of the motorcycle from the lifting gear. (📖 p. 86)



13.10 Adjusting the chain tension



Warning

Danger of accidents Incorrect chain tension damages components and results in accidents.

If the chain is tensioned too much, the chain, engine sprocket, rear sprocket, transmission and rear wheel bearings wear more quickly. Some components may break if overloaded.

If the chain is too loose, the chain may fall off the engine sprocket or the rear sprocket. As a result, the rear wheel locks or the engine will be damaged.

- Check the chain tension regularly.
- Set the chain tension in accordance with the specification.

Preparatory work

- Raise motorcycle with rear lifting gear. (📖 p. 86)
- Check the chain tension. (📖 p. 89)

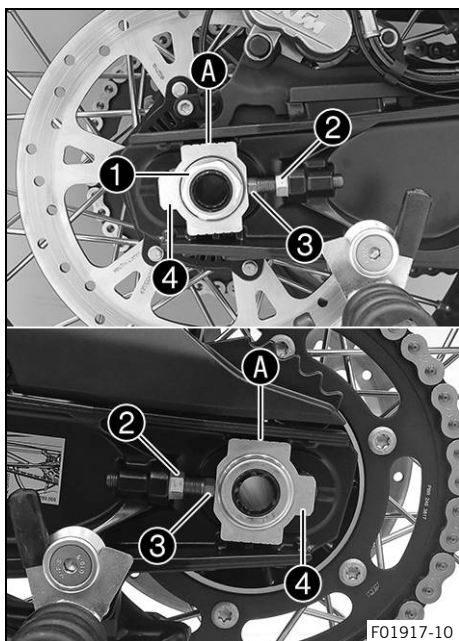

Main work

- Loosen nut ①.
- Loosen nuts ②.
- Adjust the chain tension by turning adjusting screws ③ left and right.

Guideline

Chain tension	2 ... 5 mm (0.08 ... 0.2 in)
Turn the adjusting screws ③ on the left and right so that the markings on the left and right chain adjusters ④ are in the same position relative to the reference marks ①. The rear wheel is then correctly aligned.	

i Info

The top chain section must be taut. Chain wear is not always even. Repeat this measurement at different chain positions.

- Tighten nuts ②.
- Make sure that chain adjusters ④ are fitted correctly on adjusting screws ③.
- Tighten nut ①.

Guideline

Nut, rear wheel spindle	M25x1.5	90 Nm (66.4 lbf ft) Thread and contact area of wheel spindle greased
-------------------------	---------	---

Finishing work

- Check the chain tension. (📖 p. 89)

13.11 Checking the chain, rear sprocket, engine sprocket, and chain guide

Preparatory work

- Raise motorcycle with rear lifting gear. (📖 p. 86)

Main work

- Check the chain, rear sprocket, and engine sprocket for wear.
 - » If the chain, rear sprocket or engine sprocket is worn:
 - Change the drivetrain kit. 🛠️

i Info

The engine sprocket, rear sprocket, and chain should always be replaced together.

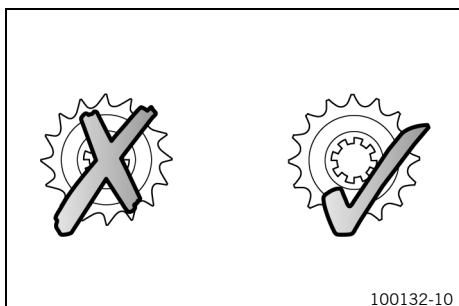

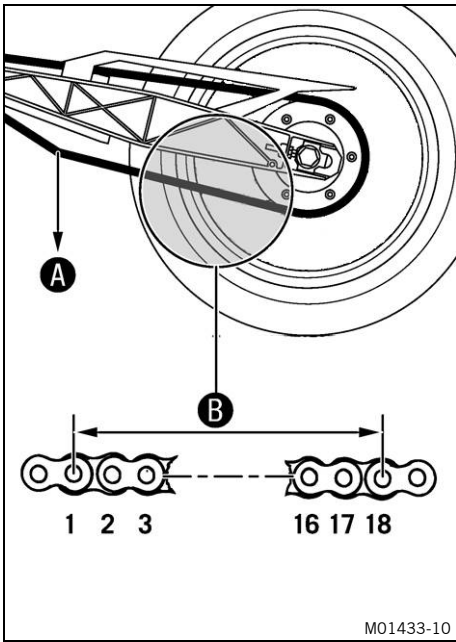

- Shift the transmission into neutral **N**.
- Pull on the lower chain section with the specified weight **A**.

Guideline

Weight, chain wear measurement	15 kg (33 lb.)
--------------------------------	----------------

- Measure distance **B** of 18 chain rollers in the lower chain section.

i Info
Chain wear is not always even. Repeat this measurement at different chain positions.

Maximum distance B from 18 chain rollers at the longest chain section	272 mm (10.71 in)
--	-------------------

- » If distance **B** is greater than the specified measurement:
 - Change the drivetrain kit. 🛠️

i Info
When a new chain is mounted, the rear sprocket and engine sprocket should also be changed. New chains wear out faster on old, worn sprockets. For safety reasons, the chain has no chain joint.

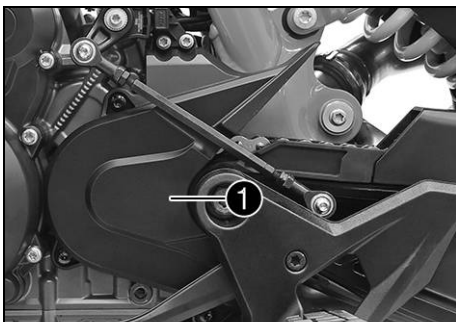

- Check the engine sprocket cover **1** for wear.
 - » If the engine sprocket cover is highly worn in the marked area **C**:
 - Change the engine sprocket cover. 🛠️
- Check the engine sprocket cover **1** for tightness.
 - » If the engine sprocket cover is loose:
 - Tighten the screws on the engine sprocket cover.

Guideline

Screw, engine sprocket cover	M5	5 Nm (3.7 lbf ft) Loctite®243™
------------------------------	----	--

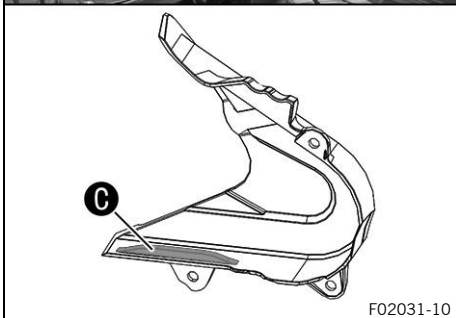

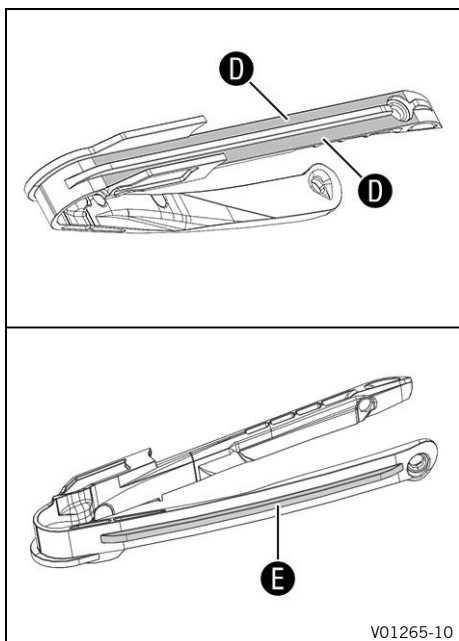

- Check the chain sliding guard for wear.
 - » If continuous signs of wear to the chain are visible on the chain sliding guard in the area **D** marked:
 - Change the chain sliding guard. 🛠️
 - » If the chain sliding guard is highly worn on the underside in the marked area **E**:
 - Change the chain sliding guard. 🛠️
- Check that the chain sliding guard is firmly seated.
 - » If the chain sliding guard is loose:
 - Tighten screws on the chain sliding guard.

Guideline

Remaining screws, chassis	M5	5 Nm (3.7 lbf ft)
---------------------------	----	-------------------

Finishing work

- Remove the rear of the motorcycle from the lifting gear. (📖 p. 86)

13.12 Removing the left side cover

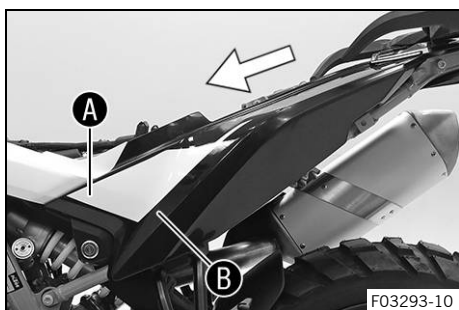

Preparatory work

- Remove the seat. (📖 p. 87)

Main work

- Remove left side cover from the rubber bushings in the areas **A** and **B**.
- Pull off the left side cover sideways and remove it toward the front.

13.13 Installing the left side cover

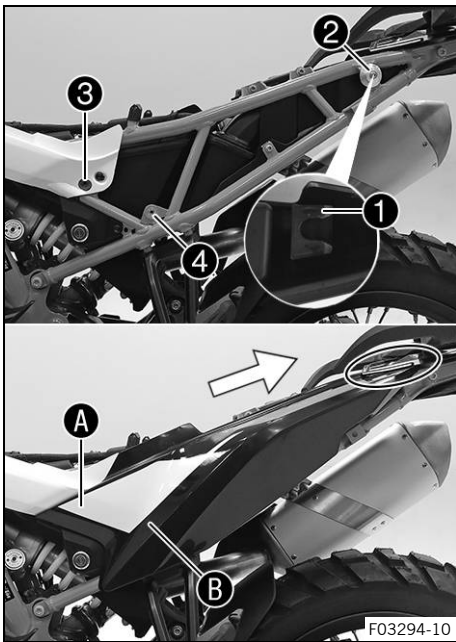

Main work

- Position the left side cover with holding lug ① on bushing ② and push backward.
- ✓ The left side cover engages under the tail part.
- Press the left side cover in area ① into rubber bushing ③ and press into rubber bushing ④ in area ④.

Finishing work

- Mount the seat. (📖 p. 87)



13.14 Removing the right side cover

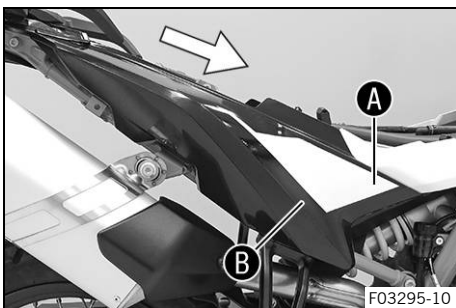

Preparatory work

- Remove the seat. (📖 p. 87)

Main work

- Remove the side cover from the rubber bushings in areas ① and ②.
- Pull off the right side cover sideways and remove it toward the front.



13.15 Installing the right side cover

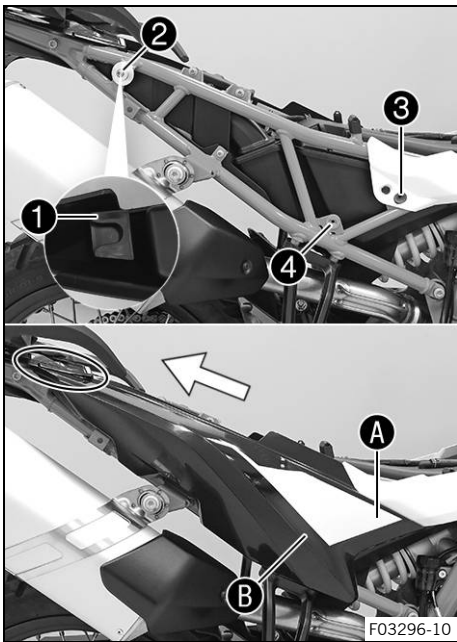

Main work

- Position the right side cover with holding lug ① on bushing ② and push backward.
 - ✓ The right side cover engages under the tail part.
- Press the right side cover in the area A into rubber bushing ③ and press into rubber bushing B in area ④.

Finishing work

- Mount the seat. (📖 p. 87)

13.16 Removing the battery cover

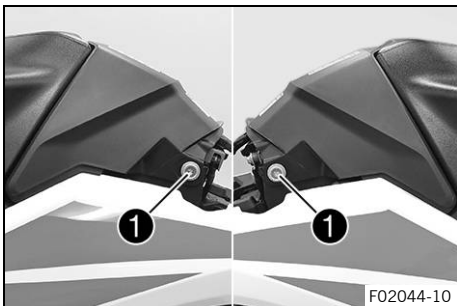

Preparatory work

- Remove the seat. (📖 p. 87)

Main work

- Remove screws ① with the bushings.
- Remove the battery cover from above.

13.17 Installing the battery cover

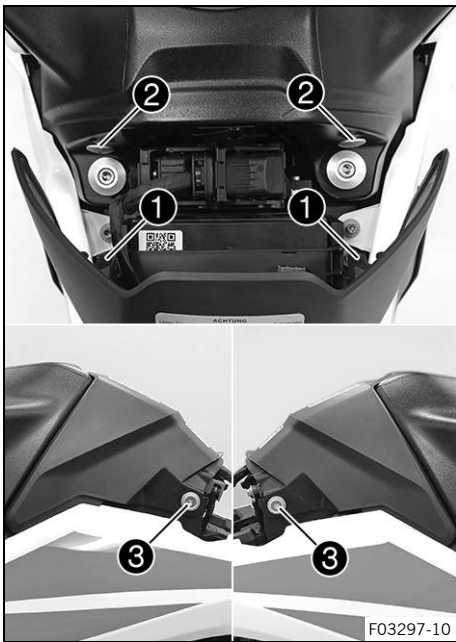

Main work

- Position the battery cover with holding lugs ① on bushings ② and push downward.
- ✓ The battery cover engages on the left and right under the fuel tank spoiler.
- Mount screws ③ with the bushings and tighten.

Guideline

Screw, seat fixing	M6	6 Nm (4.4 lbf ft)
--------------------	----	-------------------

Finishing work

- Mount the seat. (📖 p. 87)



13.18 Removing left fuel tank spoiler

Preparatory work

- Remove the seat. (📖 p. 87)
- Remove the left side cover. (📖 p. 92)
- Remove the battery cover. (📖 p. 94)

Main work

- Remove screw ①.
- Remove screws ②.

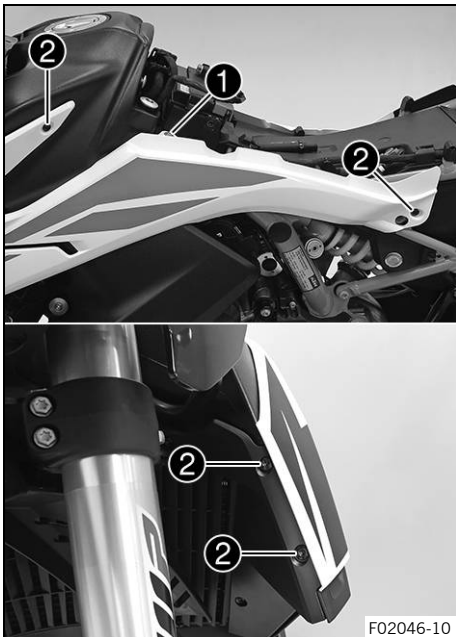



- Remove the left fuel tank spoiler from the rubber bushing in area **A**.
- Pull off the left fuel tank spoiler sideways and remove it toward the front.

13.19 Installing the left fuel tank spoiler

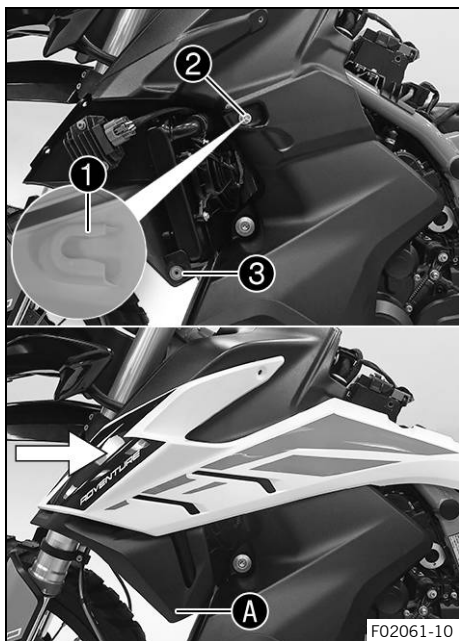

Main work

- Position the left fuel tank spoiler with holding lug **1** on bushing **2** and push backward laterally.
- Press the fuel tank spoiler into rubber bushing **3** in area **A**.

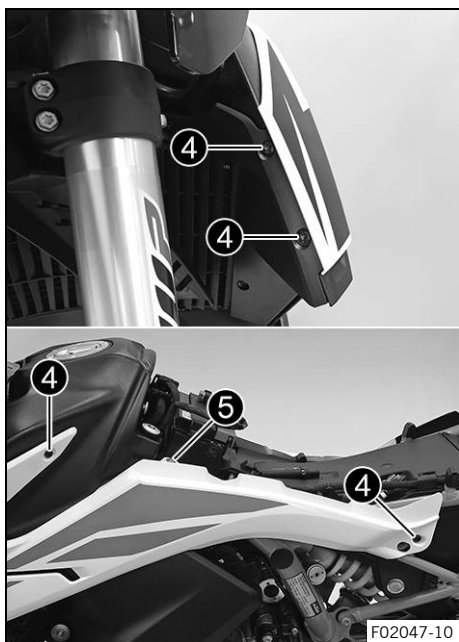

- Mount screws **4**, but do not tighten yet.

Guideline

Screw, trim	M5	3 Nm (2.2 lbf ft)
-------------	----	-------------------

- Mount screw **5**, but do not tighten yet.

Guideline

Screw, fuel tank spoiler	M6	5 Nm (3.7 lbf ft)
--------------------------	----	-------------------

- ✓ The front edge of the left fuel tank spoiler is evenly aligned.

- Tighten all the screws of the left fuel tank spoiler.

Guideline

Screw, trim	M5	3 Nm (2.2 lbf ft)
Screw, fuel tank spoiler	M6	5 Nm (3.7 lbf ft)

Finishing work

- Install the battery cover. (📖 p. 95)
- Install the left side cover. (📖 p. 93)
- Mount the seat. (📖 p. 87)



13.20 Removing right fuel tank spoiler

Preparatory work

- Remove the seat. (📖 p. 87)
- Remove the right side cover. (📖 p. 93)
- Remove the battery cover. (📖 p. 94)

Main work

- Remove screw ①.
- Remove screws ②.

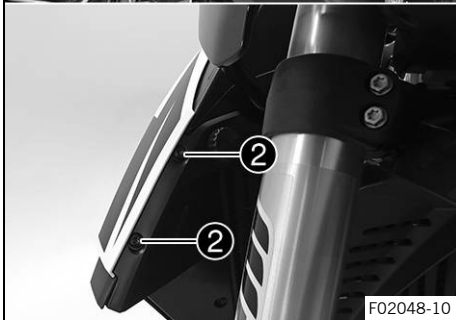
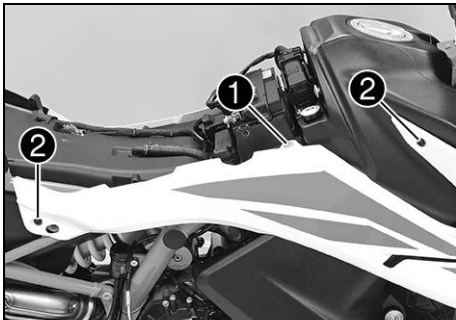

F02048-10

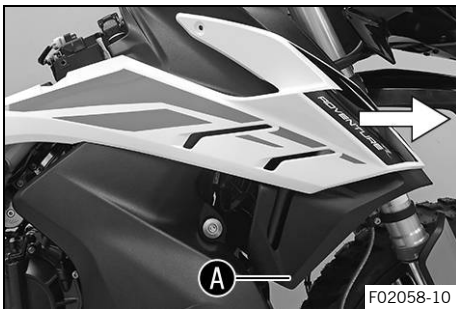

F02058-10

- Remove the fuel tank spoiler from the rubber bushing in area A.
- Pull off the right fuel tank spoiler sideways and remove it toward the front.



13.21 Installing the right fuel tank spoiler



Main work

- Position the right fuel tank spoiler with holding lug ① on bushing ② and push backward laterally.
- Press the right fuel tank spoiler into rubber bushing ③ in area A.

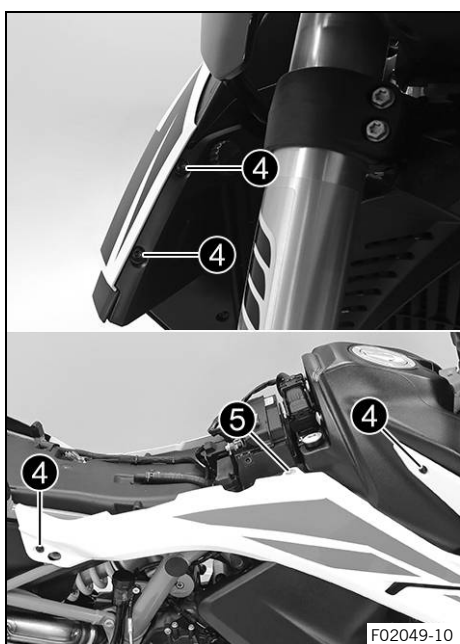

- Mount screws ④, but do not tighten yet.

Guideline

Screw, trim	M5	3 Nm (2.2 lbf ft)
-------------	----	-------------------

- Mount screw ⑤, but do not tighten yet.

Guideline

Screw, fuel tank spoiler	M6	5 Nm (3.7 lbf ft)
--------------------------	----	-------------------

- ✓ The front edge of the right fuel tank spoiler is evenly aligned.

- Tighten all the screws of the right fuel tank spoiler.

Guideline

Screw, trim	M5	3 Nm (2.2 lbf ft)
Screw, fuel tank spoiler	M6	5 Nm (3.7 lbf ft)

Finishing work

- Install the battery cover. (📖 p. 95)
- Install the right side cover. (📖 p. 94)
- Mount the seat. (📖 p. 87)

13.22 Removing the front fender

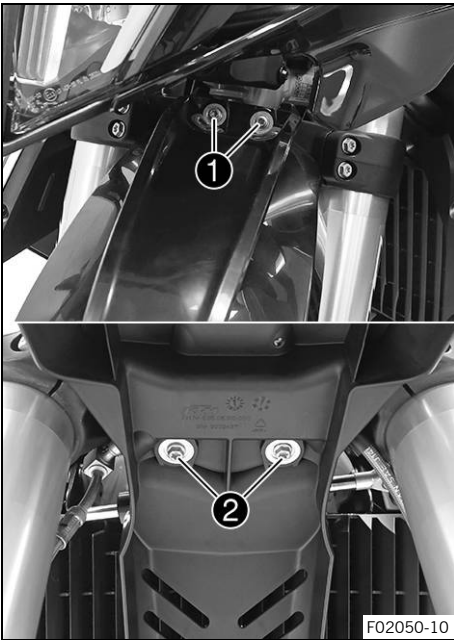

- Remove screws ①.
- Remove screws ②.
- Take the fender off to the front.

13.23 Installing the front fender

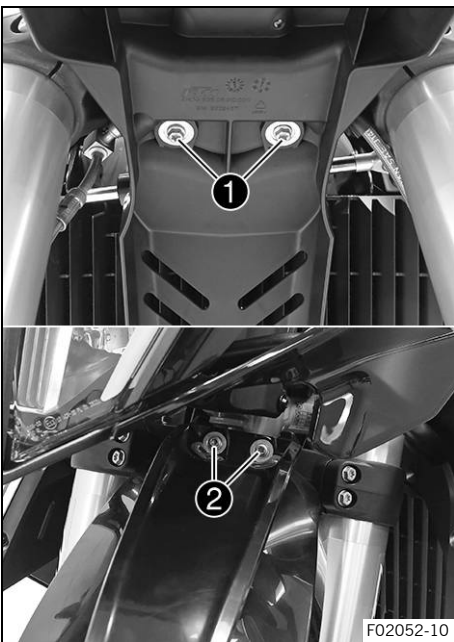

- Position the front fender. Mount screws ①, but do not tighten yet.

Guideline

Remaining screws, chassis	M6	10 Nm (7.4 lbf ft)
---------------------------	----	--------------------

- Mount screws ②, but do not tighten yet.

Guideline

Remaining screws, chassis	M6	10 Nm (7.4 lbf ft)
---------------------------	----	--------------------

✓ The fender is evenly aligned to the front.

- Tighten all screws on the front fender.

Guideline

Remaining screws, chassis	M6	10 Nm (7.4 lbf ft)
---------------------------	----	--------------------

13.24 Removing fork protector

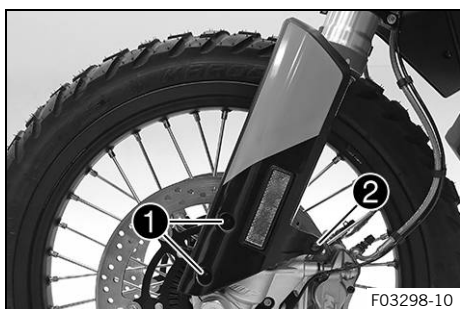

- Remove screws ❶.
- Remove screw ❷.
- Take off the fork protector at the front.
- Repeat these steps on the opposite side.

13.25 Installing the fork protector



- Position the fork protector. Mount screw ❶, but do not tighten yet.

Guideline

Screw, fork protector	M5x12	5 Nm (3.7 lbf ft)
-----------------------	-------	-------------------

- Mount screws ❷, but do not tighten yet.

Guideline

Screw, fork protector	M5x17	5 Nm (3.7 lbf ft)
-----------------------	-------	-------------------

✓ The fork protector is evenly aligned to the front.

- Tighten all screws of the fork protector.

Guideline

Screw, fork protector	M5x12	5 Nm (3.7 lbf ft)
Screw, fork protector	M5x17	5 Nm (3.7 lbf ft)

- Repeat these steps on the opposite side.

13.26 Cleaning the dust boots of the fork legs

Preparatory work

- Raise motorcycle with rear lifting gear. (📖 p. 86)
- Remove the front fender. (📖 p. 99)
- Lift the motorcycle with the front lifting gear. (📖 p. 86)

Main work

- Push dust boots ❶ of both fork legs downward.

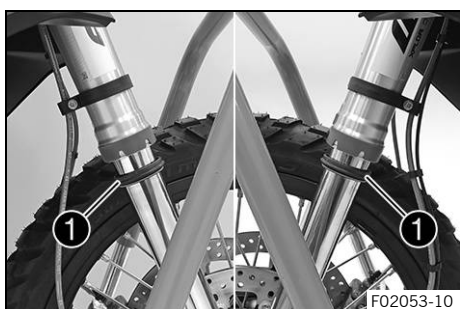

Info

The dust boots remove dust and coarse dirt particles from the inside fork tubes. Over time, dirt can accumulate behind the dust boots. If this dirt is not removed, the oil seals behind can start to leak.

**Warning**

Danger of accidents Oil or grease on the brake discs reduces the braking effect.

- Always keep the brake discs free of oil and grease.
- Clean the brake discs with brake cleaner when necessary.

- Clean and oil the dust boots and inside fork tubes of both fork legs.

Universal oil spray (📖 p. 165)

- Press the dust boots back into the installation position.
- Remove the excess oil.

Finishing work

- Take the motorcycle off the front lifting gear. (📖 p. 87)
- Install the front fender. (📖 p. 99)
- Remove the rear of the motorcycle from the lifting gear. (📖 p. 86)

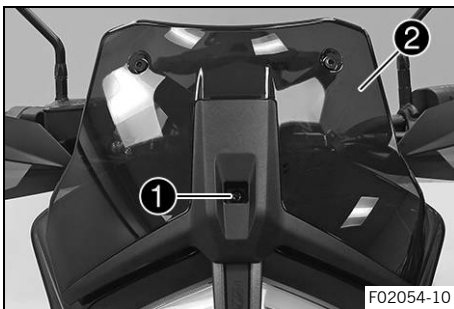
**13.27 Removing the windshield**

- Remove screw ① and windshield ②.



13.28 Installing the windshield

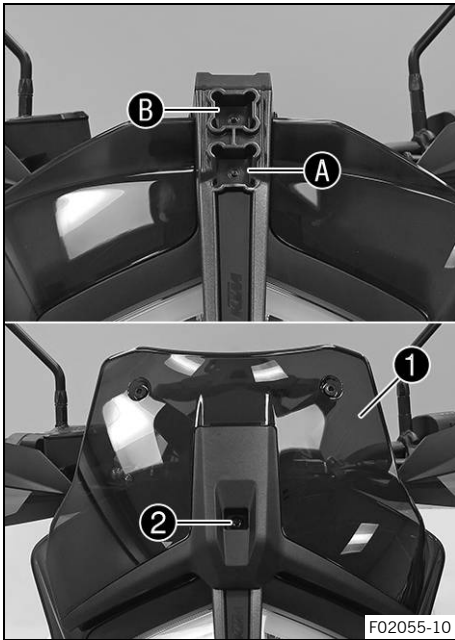

- Position windshield ① in upper recess ① or in lower recess ②.
- Mount and tighten screw ③.

Guideline

Remaining screws, chassis	M5	5 Nm (3.7 lbf ft)
---------------------------	----	-------------------

13.29 Removing left fuel tank cover

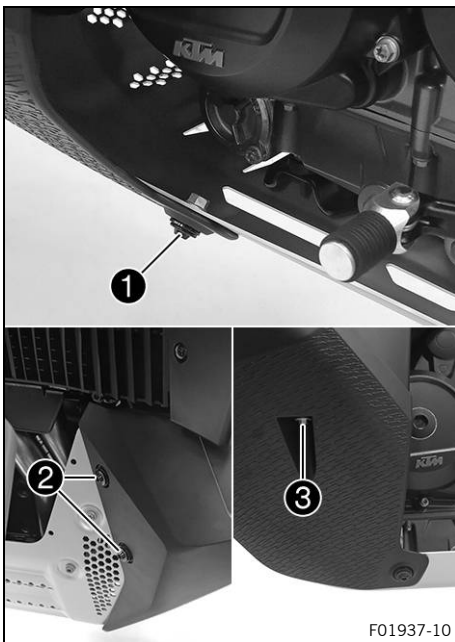

- Remove fitting ①.
- Remove screws ②.
- Remove screw ③.
- Remove left fuel tank cover.

13.30 Installing the left fuel tank cover

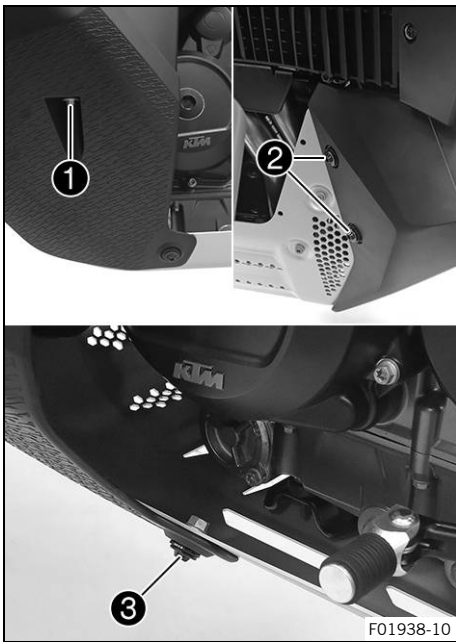

- Position the left fuel tank cover.
- Mount and tighten screw 1.

Guideline

Screw, fuel tank cover	M6x12	8 Nm (5.9 lbf ft)
------------------------	-------	-------------------

- Mount screws 2, but do not tighten yet.

Guideline

Screw, fuel tank cover	M6x22	8 Nm (5.9 lbf ft)
------------------------	-------	-------------------

- Mount fitting 3, but do not tighten yet.

Guideline

Screw cap, fuel tank cover	M6	5 Nm (3.7 lbf ft)
----------------------------	----	-------------------

✓ The left fuel tank cover is directed evenly toward the front.

- Tighten all the screws of the left fuel tank cover.

Guideline

Screw, fuel tank cover	M6x12	8 Nm (5.9 lbf ft)
Screw, fuel tank cover	M6x22	8 Nm (5.9 lbf ft)
Screw cap, fuel tank cover	M6	5 Nm (3.7 lbf ft)



13.31 Removing right fuel tank cover

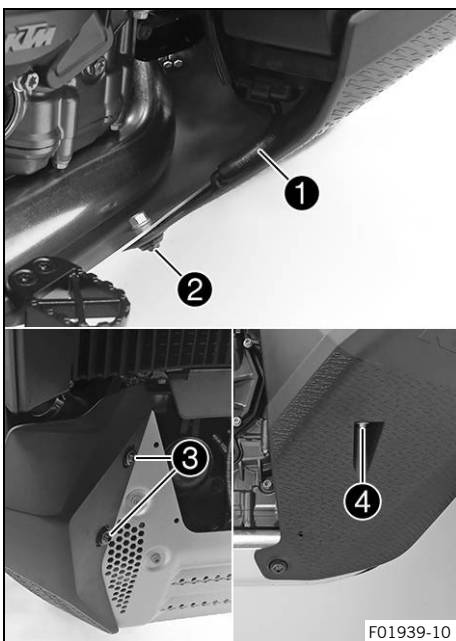

- Pull out tube 1 from the angle piece.
- Remove fitting 2.
- Remove screws 3.
- Remove screw 4.
- Remove right fuel tank cover.



13.32 Installing the right fuel tank cover

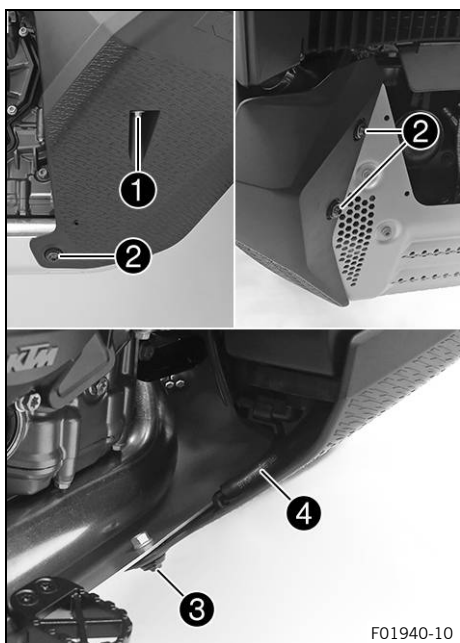

- Position the right fuel tank cover.

- Mount and tighten screw **1**.

Guideline

Screw, fuel tank cover	M6x12	8 Nm (5.9 lbf ft)
------------------------	-------	-------------------

- Mount screws **2**, but do not tighten yet.

Guideline

Screw, fuel tank cover	M6x22	8 Nm (5.9 lbf ft)
------------------------	-------	-------------------

- Mount fitting **3**, but do not tighten yet.

Guideline

Screw cap, fuel tank cover	M6	5 Nm (3.7 lbf ft)
----------------------------	----	-------------------

- ✓ The right fuel tank cover is directed evenly toward the front.

- Tighten all the screws of the right fuel tank cover.

Guideline

Screw, fuel tank cover	M6x12	8 Nm (5.9 lbf ft)
Screw, fuel tank cover	M6x22	8 Nm (5.9 lbf ft)
Screw cap, fuel tank cover	M6	5 Nm (3.7 lbf ft)

- Attach tube **4** to the angle piece.

13.33 Removing engine guard



- Pull out tube **1** from the angle piece.

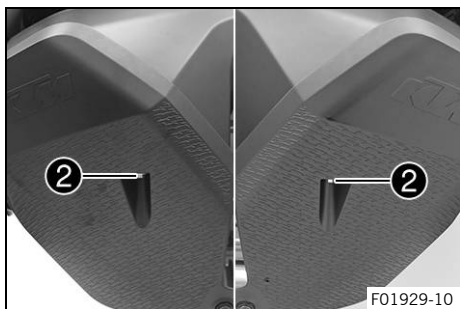

- Remove screws **2**.

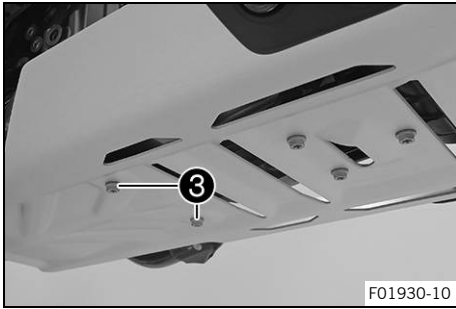

- Remove screws ③.

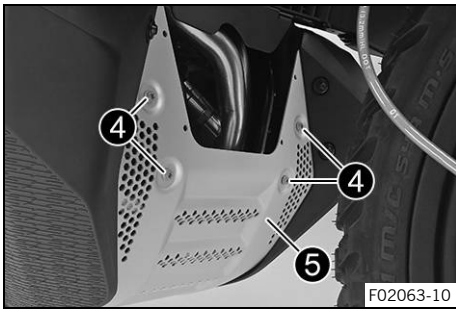

- Remove screws ④ and engine guard ⑤.

13.34 Installing the engine guard

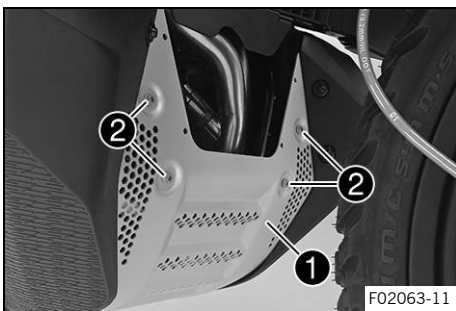

- Position engine guard ①.
- Mount screws ②, but do not tighten yet.

Guideline

Screw, engine guard	M6x10	10 Nm (7.4 lbf ft) Loctite®243™
---------------------	-------	---

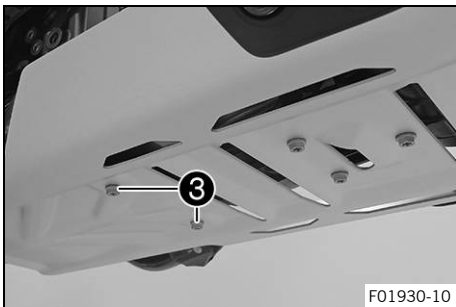

- Mount screws ③, but do not tighten yet.

Guideline

Screw, engine guard	M6x8	8 Nm (5.9 lbf ft)
---------------------	------	-------------------

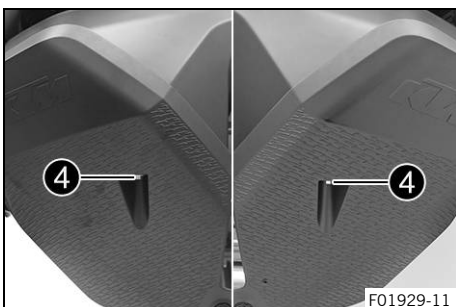

- Mount screws ④, but do not tighten yet.

Guideline

Screw, fuel tank cover	M6x12	8 Nm (5.9 lbf ft)
------------------------	-------	-------------------

- ✓ The engine guard is directed evenly toward the front.

- Tighten all the screws of the engine guard.

13 SERVICE WORK ON THE CHASSIS

Guideline

Screw, engine guard	M6x8	8 Nm (5.9 lbf ft)
Screw, engine guard	M6x10	10 Nm (7.4 lbf ft) Loctite®243™
Screw, fuel tank cover	M6x12	8 Nm (5.9 lbf ft)

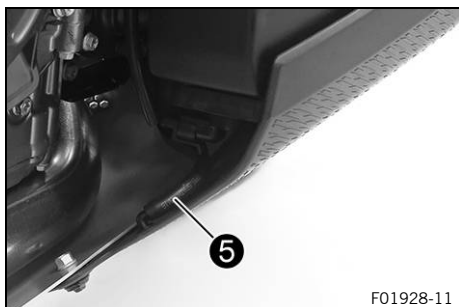

- Attach tube **5** to the angle piece.

13.35 Removing the main silencer

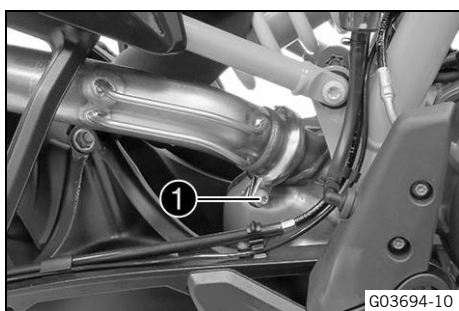

- Remove screw **1**.
- Remove the clamp.

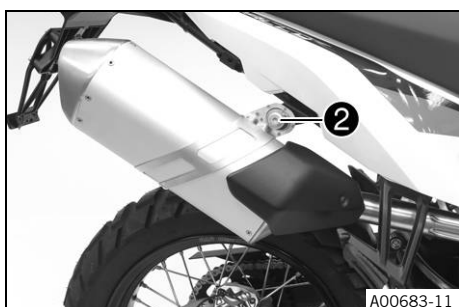

- Remove screw **2** with the washer.
- Take off the main silencer.

13.36 Installing the main silencer



- Position the main silencer with the gasket.
- Mount screw **1** with the washer, but do not tighten yet.

Guideline

Screw, main silencer holder	M8	25 Nm (18.4 lbf ft)
-----------------------------	----	---------------------

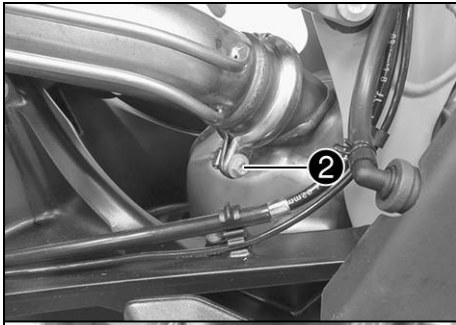

- Position the clamp.

Guideline

Distance A	1 mm (0.04 in)
-------------------	----------------

i **Info**

The clamp must not touch the brake line when the rear wheel suspension compresses.

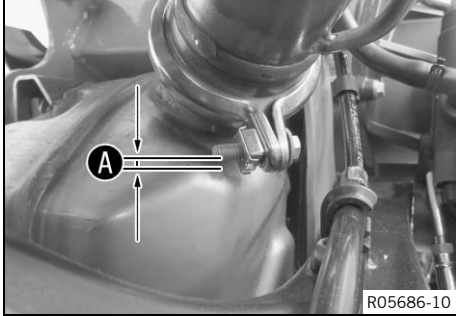

- Mount and tighten screw **2**.

Guideline

Screw, presilencer exhaust clamp	M6	8 Nm (5.9 lbf ft) Copper paste
----------------------------------	----	-----------------------------------

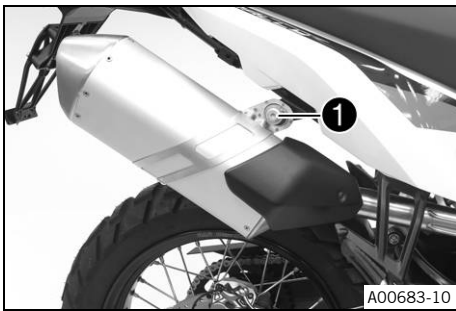

- Tighten screw **1**.

Guideline

Screw, main silencer holder	M8	25 Nm (18.4 lbf ft)
-----------------------------	----	---------------------

14.1 Anti-lock braking system (ABS)

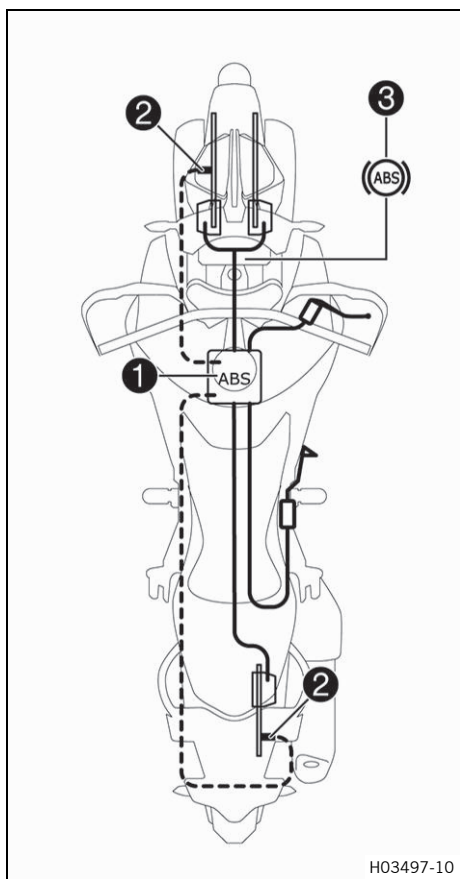

The **ABS** module **1**, which consists of a hydraulic unit, ABS control unit, and return pump, is installed under the fuel tank. One wheel speed sensor **2** is located in each case on the front and the rear wheel.



Warning

Danger of accidents Changes to the vehicle impair the function of the ABS.

- Do not make any changes to the suspension travel.
- Only use spare parts on the brake system which have been approved and recommended by KTM.
- Only use tires/wheels approved by KTM with the corresponding speed index.
- Maintain the specified tire pressure.
- Ensure that service work and repairs are performed professionally. (Your authorized KTM workshop will be glad to help.)

The **ABS** is a safety system that prevents locking of the wheels when driving straight ahead or when cornering (within the limits of physics).



Warning

Danger of accidents Driving aids can reduce the probability of a fall only within physical limits.

It is not always possible to compensate for extreme riding situations, for example with luggage loaded with a high center of gravity, varying road surfaces, steep descents or full braking without disengaging the gear.

- Adapt your riding style to the road conditions and your driving ability.



Warning

Danger of accidents An incorrectly selected ABS mode makes control of the vehicle considerably more difficult.

The ABS modes are each only suitable for certain conditions.

- Always select an ABS mode that is compatible with the surface of the ground.

ABS has two operating modes: the **Road** and **Offroad**ABS modes.

In **Road** ABS mode, the ABS controls both wheels.

In ABS mode **Offroad** there is no ABS control on the rear wheel.



Info

In the **Offroad** ABS mode, the rear wheel may lock and there is a risk of falling.

The curve dependent control is only active in ABS mode **Road**.

The ABS operates with two independent brake circuits (front and rear brakes). When the ABS control unit detects a locking tendency in a wheel, ABS begins regulating the brake pressure. The control function causes a slight pulsing of the hand and foot brake levers.

The ABS warning lamp **3** must light up after the ignition is switched on and go out after starting off. If it does not go out after starting off or if it is lit while riding, this indicates a fault in the ABS. In this case, the ABS is no longer enabled and the wheels may lock during braking. The brake system itself stays functional; only ABS control is not available.

The ABS warning lamp may also light up if the rotating speeds of the front and rear wheels differ greatly under extreme riding conditions, for example when making "wheelies" or if the rear wheel spins. This causes the ABS to switch off.

To reactivate the ABS, stop the vehicle and switch off the ignition. The ABS is reactivated when the vehicle is switched on again. The ABS warning lamp goes out after starting off.

14.2 Checking brake discs



Warning

Danger of accidents Worn-out brake discs reduce the braking effect.

- Make sure that worn-out brake discs are replaced immediately. (Your authorized KTM workshop will be glad to help.)

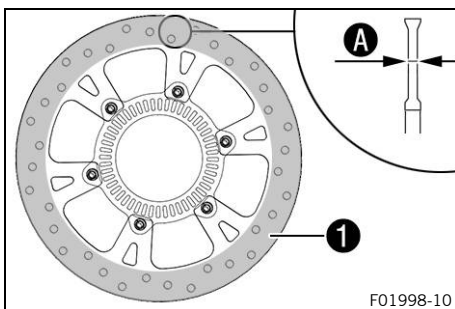

- Check front and rear brake disc thickness at multiple points for the dimension **A**.

Info

Wear will reduce the thickness of the brake disc at contact surface **1** of the brake linings.

Brake discs - wear limit	
front	4.5 mm (0.177 in)
rear	4.5 mm (0.177 in)

- » If the brake disc thickness is less than the specified value.
 - Change the front brake discs. 🛠️
 - Change the rear brake disc. 🛠️
- Check front and rear brake discs for damage, cracking, and deformation.
 - » If the brake disc exhibits damage, cracking, or deformation:
 - Change the front brake discs. 🛠️
 - Change the rear brake disc. 🛠️



14.3 Checking the front brake fluid level



Warning

Danger of accidents An insufficient brake fluid level will cause the brake system to fail.

If the brake fluid level drops below the specified marking or the specified value, the brake system is leaking or the brake linings are worn down.

- Check the brake system and do not continue riding until the problem is eliminated. (Your authorized KTM workshop will be glad to help.)



Warning

Danger of accidents Old brake fluid reduces the braking effect.

- Make sure that brake fluid for the front and rear brake is changed in accordance with the service schedule. (Your authorized KTM workshop will be glad to help.)

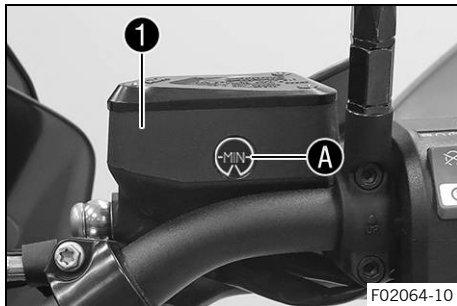

- Move the brake fluid reservoir mounted on the handlebar to a horizontal position.
- Check the brake fluid level in brake fluid reservoir **1**.
 - » If the brake fluid level has dropped below **MIN** marking **A**:
 - Add front brake fluid. 🛠️ (p. 110)

14.4 Adding front brake fluid 🛠️



Warning

Danger of accidents An insufficient brake fluid level will cause the brake system to fail.

If the brake fluid level drops below the specified marking or the specified value, the brake system is leaking or the brake linings are worn down.

- Check the brake system and do not continue riding until the problem is eliminated. (Your authorized KTM workshop will be glad to help.)



Warning

Skin irritation Brake fluid causes skin irritation.

- Keep brake fluid out of the reach of children.
- Wear suitable protective clothing and safety glasses.
- Do not allow brake fluid to come into contact with the skin, the eyes or clothing.
- Consult a doctor immediately if brake fluid has been swallowed.
- Rinse the affected area with plenty of water in the event of contact with the skin.
- Rinse eyes thoroughly with water immediately and consult a doctor if brake fluid comes into contact with the eyes.
- If brake fluid spills on to your clothing, change the clothing.



Warning

Danger of accidents Old brake fluid reduces the braking effect.

- Make sure that brake fluid for the front and rear brake is changed in accordance with the service schedule. (Your authorized KTM workshop will be glad to help.)



Note

Environmental hazard Hazardous substances cause environmental damage.

- Dispose of oils, grease, filters, fuel, cleaning agents, brake fluid, etc., correctly and in compliance with the applicable regulations.



Info

Never use DOT 5 brake fluid. It is silicone-based and purple in color. Oil seals and brake lines are not designed for DOT 5 brake fluid.

Avoid contact between brake fluid and painted parts. Brake fluid corrodes paint.

Only use clean brake fluid from a sealed container.

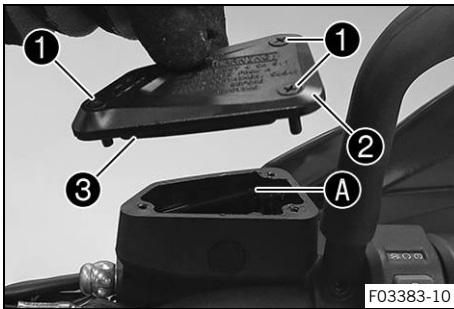

Preparatory work

- Check the front brake linings. (📖 p. 111)

Main work

- Move the brake fluid reservoir mounted on the handlebar to a horizontal position.
- Remove screws ①.
- Take off cover ② with membrane ③.
- Add brake fluid up to the marking A.

Brake fluid DOT 4 / DOT 5.1 (📖 p. 163)
--

- Position cover ② with membrane ③.
- Mount and tighten screws ①.

Guideline

Brake fluid reservoir cover, front	-	1 Nm (0.7 lbf ft)
------------------------------------	---	-------------------



Info

Use water to immediately clean up any brake fluid that has overflowed or spilled.

14.5 Checking the front brake linings



Warning

Danger of accidents Worn-out brake linings reduce the braking effect.

- Ensure that worn-out brake linings are replaced immediately. (Your authorized KTM workshop will be glad to help.)



Warning

Danger of accidents Damaged brake discs reduce the braking effect.

If the brake linings are not changed in time, the brake lining carriers grind against the brake disc. As a consequence, the braking effect is greatly reduced and the brake discs are destroyed.

- Check the brake linings regularly.

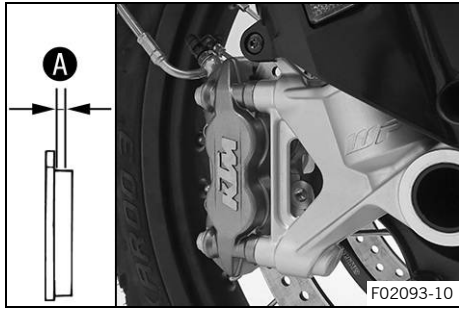

- Check all brake linings on both brake calipers to ensure they have the minimum thickness **A**.

Minimum thickness A	$\geq 1 \text{ mm } (\geq 0.04 \text{ in})$
----------------------------	---

- » If the minimum thickness is less than specified:
 - Change the front brake linings. 🛠️
- Check all brake linings on both brake calipers for damage and cracking.
 - » If there is damage or cracking:
 - Change the front brake linings. 🛠️

14.6 Checking the free travel of the foot brake lever



Warning

Danger of accidents The brake system fails in the event of overheating.

If there is no free travel on the foot brake lever, pressure builds up in the brake system on the rear brake.

- Set the free travel on the foot brake lever in accordance with the specification.

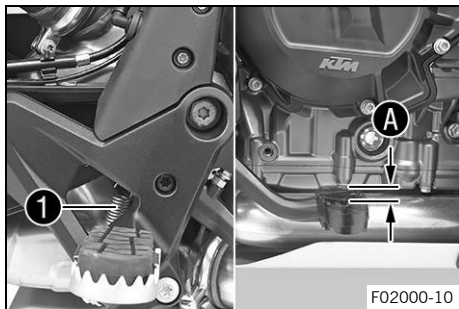

- Detach spring **1**.
- Move the foot brake lever back and forth between the end stop and the contact to the foot brake cylinder piston and check free travel **A**.

Guideline

Free travel at foot brake lever	3 ... 5 mm (0.12 ... 0.2 in)
---------------------------------	------------------------------

- » If the free travel does not match the specification:
 - Adjust the basic position of the foot brake lever. 🛠️ (📖 p. 63)
- Attach spring **1**.

14.7 Checking the rear brake fluid level



Warning

Danger of accidents An insufficient brake fluid level will cause the brake system to fail.

If the brake fluid level drops below the **MIN** marking, the brake system is leaking or the brake linings are worn down.

- Check the brake system and do not continue riding until the problem is eliminated. (Your authorized KTM workshop will be glad to help.)



Warning

Danger of accidents Old brake fluid reduces the braking effect.

- Make sure that brake fluid for the front and rear brake is changed in accordance with the service schedule. (Your authorized KTM workshop will be glad to help.)

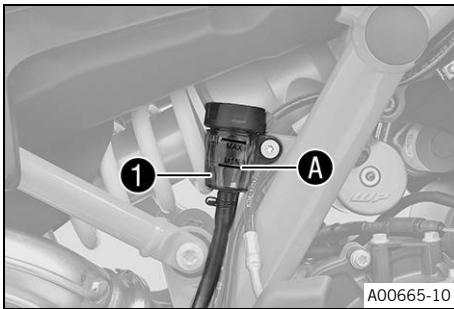

- Position the vehicle upright.
- Check the brake fluid level in brake fluid reservoir ①.
 - » If the fluid level reaches the **MIN** marking A:
 - Add rear brake fluid. 🗨️ (p. 113)

14.8 Adding rear brake fluid 🗨️



Warning

Danger of accidents An insufficient brake fluid level will cause the brake system to fail.

If the brake fluid level drops below the **MIN** marking, the brake system is leaking or the brake linings are worn down.

- Check the brake system and do not continue riding until the problem is eliminated. (Your authorized KTM workshop will be glad to help.)



Warning

Skin irritation Brake fluid causes skin irritation.

- Keep brake fluid out of the reach of children.
- Wear suitable protective clothing and safety glasses.
- Do not allow brake fluid to come into contact with the skin, the eyes or clothing.
- Consult a doctor immediately if brake fluid has been swallowed.
- Rinse the affected area with plenty of water in the event of contact with the skin.
- Rinse eyes thoroughly with water immediately and consult a doctor if brake fluid comes into contact with the eyes.
- If brake fluid spills on to your clothing, change the clothing.



Warning

Danger of accidents Old brake fluid reduces the braking effect.

- Make sure that brake fluid for the front and rear brake is changed in accordance with the service schedule. (Your authorized KTM workshop will be glad to help.)



Note

Environmental hazard Hazardous substances cause environmental damage.

- Dispose of oils, grease, filters, fuel, cleaning agents, brake fluid, etc., correctly and in compliance with the applicable regulations.



Info

Never use DOT 5 brake fluid. It is silicone-based and purple in color. Oil seals and brake lines are not designed for DOT 5 brake fluid.

Avoid contact between brake fluid and painted parts. Brake fluid corrodes paint.

Only use clean brake fluid from a sealed container.

Preparatory work

- Check the rear brake linings. 🗨️ (p. 114)

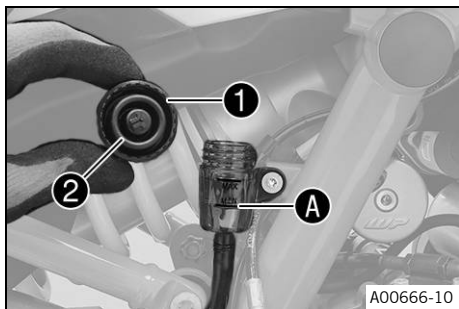

Main work

- Position the vehicle vertically.
- Remove screw cover **1** with insert and membrane **2**.
- Add brake fluid up to the **MAX** marking **A**.

Brake fluid DOT 4 / DOT 5.1 (🗨️ p. 163)

- Mount and tighten screw cover **1** with the insert and membrane **2**.

Guideline

Brake fluid reservoir cover, rear	-	1.5 Nm (1.11 lbf ft)
-----------------------------------	---	-------------------------

i Info

Use water to immediately clean up any brake fluid that has overflowed or spilled.

14.9 Checking the rear brake linings



Warning

Danger of accidents Worn-out brake linings reduce the braking effect.

- Ensure that worn-out brake linings are replaced immediately. (Your authorized KTM workshop will be glad to help.)



Warning

Danger of accidents Damaged brake discs reduce the braking effect.

If the brake linings are not changed in time, the brake lining carriers grind against the brake disc. As a consequence, the braking effect is greatly reduced and the brake discs are destroyed.

- Check the brake linings regularly.

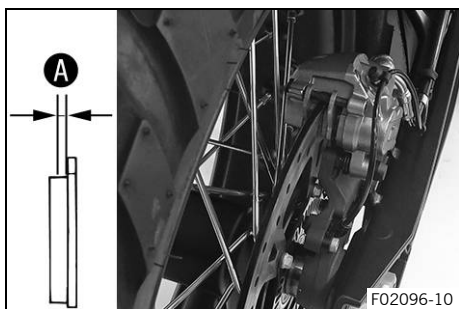

- Check the brake linings for minimum thickness **A**.

Minimum thickness A	≥ 1 mm (≥ 0.04 in)
----------------------------	--------------------

- » If the minimum thickness is less than specified:
 - Change the rear brake linings. 🛠️
- Check the brake linings for damage and cracking.
 - » If there is wear or tearing:
 - Change the rear brake linings. 🛠️

15.1 Removing the front wheel

Preparatory work

- Raise motorcycle with rear lifting gear. (📖 p. 86)
- Remove the front fender. (📖 p. 99)
- Lift the motorcycle with the front lifting gear. (📖 p. 86)

Main work

- Remove screw ① and pull wheel speed sensor ② out of the hole.
- Remove screws ③ and ④.
- Press back the brake linings by slightly tilting the left and right brake caliper laterally on the brake disc. Pull the left and right brake caliper carefully back from the brake disc and hang to the side.

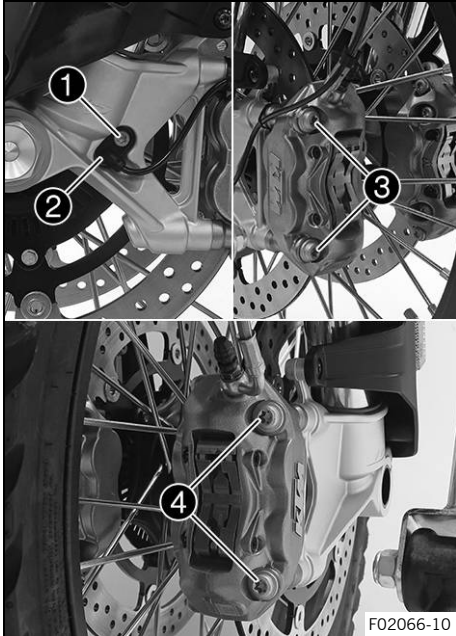

F02066-10



Info

Do not operate the hand brake lever if the brake calipers have been removed.

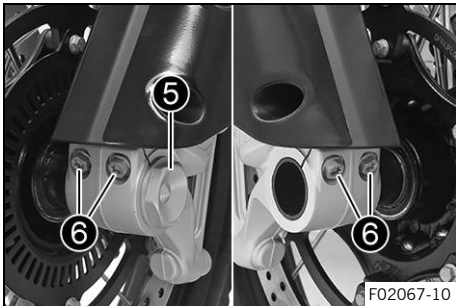

F02067-10

- Loosen screw ⑤ by several rotations.
- Loosen screws ⑥.
- Press on screw ⑤ to push the wheel spindle out of the axle clamp.
- Remove screw ⑤.



Warning

Danger of accidents Damaged brake discs reduce the braking effect.

- Always lay the wheel down in such a way that the brake discs are not damaged.

- Hold front wheel and remove wheel spindle. Take the front wheel out of the fork.
- Remove spacers ⑦.

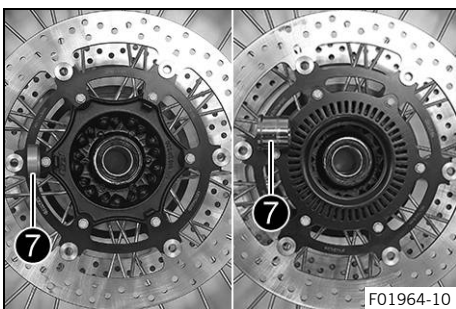

F01964-10

15.2 Installing the front wheel ↩



Warning

Danger of accidents Oil or grease on the brake discs reduces the braking effect.

- Always keep the brake discs free of oil and grease.
- Clean the brake discs with brake cleaner when necessary.

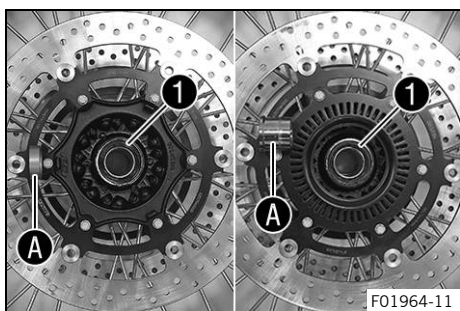

- Check the wheel bearing for damage and wear.
 - » If the wheel bearing is damaged or worn:
 - Change front wheel bearing. ↩
- Clean and grease shaft seal rings 1 and contact surfaces A of the spacers.

Long-life grease (📖 p. 165)

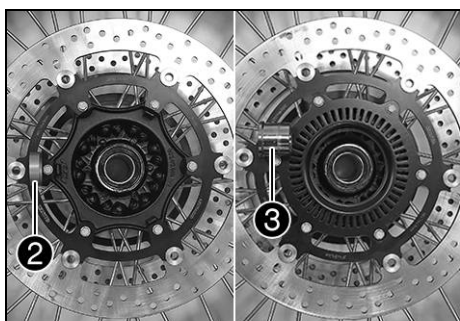

- Insert narrow spacer 2 on the right in the direction of travel.
- Insert wide spacer 3 on the left in the direction of travel.



Info

Arrow B indicates the direction of travel of the front wheel.

The wheel speed sensor wheel is on the left viewed in the direction of travel.

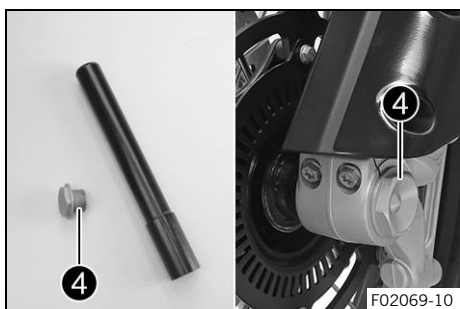
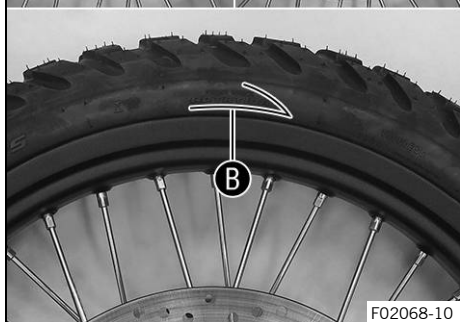

- Clean screw 4 and the wheel spindle.
- Grease wheel spindle lightly.

Long-life grease (📖 p. 165)

- Jack up the front wheel into the fork, position it, and insert the wheel spindle.
- Mount and tighten screw 4.

Guideline

Screw, front wheel spindle	M25x1.5	45 Nm (33.2 lbf ft) Thread greased
----------------------------	---------	---------------------------------------

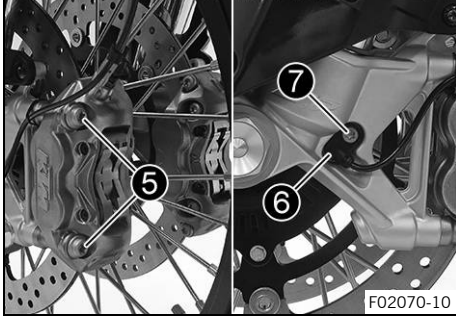

- Position both brake calipers.
- ✓ The brake linings are correctly positioned.
- Mount screws **5** on both sides but do not tighten yet.

Guideline

Screw, front brake caliper	M10x1.25	45 Nm (33.2 lbf ft) Loctite®243™
----------------------------	----------	--

- Operate the hand brake lever repeatedly until the brake linings are in contact with the brake disc and there is a pressure point. Secure the hand brake lever in the activated position.

✓ The brake calipers straighten.

- Tighten screws **5** on both sides.

Guideline

Screw, front brake caliper	M10x1.25	45 Nm (33.2 lbf ft) Loctite®243™
----------------------------	----------	--

- Position wheel speed sensor **6** in the hole.
- Mount and tighten screw **7**.

Guideline

Screw, front wheel speed sensor	M6	10 Nm (7.4 lbf ft)
---------------------------------	----	--------------------

- Remove the locking piece of the hand brake lever.
- Take the motorcycle off the front lifting gear. (📖 p. 87)
- Remove the rear of the motorcycle from the lifting gear. (📖 p. 86)
- Operate the front brake and compress the fork a few times firmly.
- ✓ The fork legs straighten.
- Tighten screws **8**.

Guideline

Screw, fork stub	M8	15 Nm (11.1 lbf ft)
------------------	----	---------------------

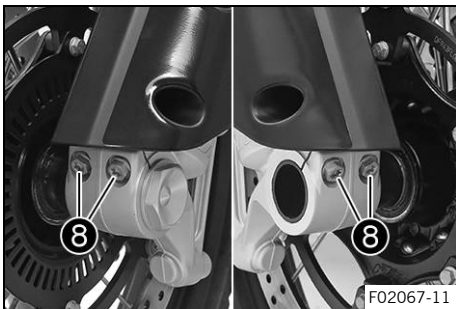

15.3 Removing the rear wheel 🛠️

Preparatory work

- Raise motorcycle with rear lifting gear. (📖 p. 86)

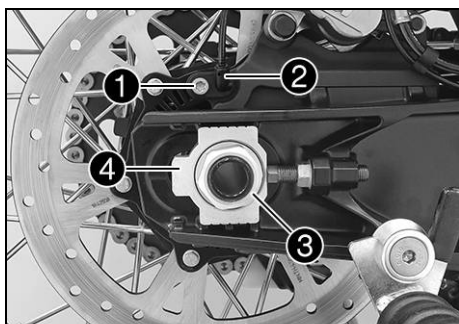

Main work

- Manually press the brake caliper toward the brake disc to push back the brake piston.
- Remove screw ① and pull wheel speed sensor ② out of the hole.
- Remove nut ③. Take off chain adjuster ④.
- Pull out wheel spindle ⑤ far enough to allow the rear wheel to be pushed forward.

- Push the rear wheel forward as far as possible. Take the chain off the rear sprocket and place it on chain sprocket guard ⑥.

Info

Cover the components to protect them against damage.

- Hold the rear wheel and remove the wheel spindle.
- Pull the rear wheel back until the brake caliper bracket is suspended freely between the brake disc and rim.

Warning

Danger of accidents Damaged brake discs reduce the braking effect.

- Always lay the wheel down in such a way that the brake disc is not damaged.

- Take the rear wheel out of the link fork.

Info

Do not operate the foot brake lever when the rear wheel is removed.

15.4 Installing the rear wheel ↩

Warning

Danger of accidents Oil or grease on the brake discs reduces the braking effect.

- Always keep the brake discs free of oil and grease.
- Clean the brake discs with brake cleaner when necessary.



Warning

Danger of accidents There is no braking effect to start with at the rear brake after installing the rear wheel.

- Actuate the foot brake several times before going on a ride until you can feel a firm pressure point.

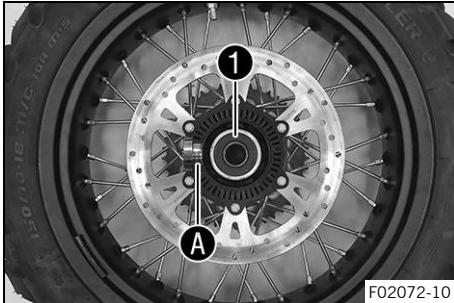

F02072-10

Main work

- Check the rear hub damping rubber pieces. 🛠️ (📖 p. 120)
- Check the wheel bearing for damage and wear.
 - » If the wheel bearing is damaged or worn:
 - Change the rear wheel bearing. 🛠️
- Remove spacer.
- Clean and grease shaft seal ring **1** and contact surface **A** of the spacer.

Long-life grease (📖 p. 165)

- Insert a spacer.
- Clean and grease the thread of the wheel spindle and nut.

Long-life grease (📖 p. 165)

- Clean and grease the wheel spindle.

Long-life grease (📖 p. 165)

- Clean the contact areas on the brake caliper bracket and link fork.

- Engage the thrust bearing of brake caliper bracket **B** and the link fork.

- Jack up the rear wheel into the link fork, position it, and insert the wheel spindle.

✓ The brake linings are correctly positioned.

- Place the chain on the sprocket.
- Position chain adjuster **2**. Mount nut **3**, but do not tighten it yet.

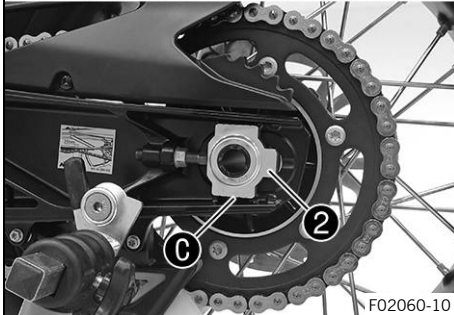
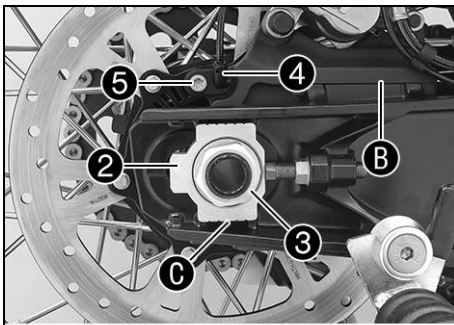

F02060-10



Info

Mount the left and right chain adjusters in the same position.

- Make sure that chain adjusters **2** are fitted correctly on the adjusting screws. Tighten nut **3**.

Guideline

In order for the rear wheel to be correctly aligned, the markings on the left and right chain adjusters must be in the same position relative to reference markings **C**.

Nut, rear wheel spindle	M25x1.5	90 Nm (66.4 lbf ft) Thread and contact area of wheel spindle greased
-------------------------	---------	---

- Position wheel speed sensor **4** in the hole.
- Mount and tighten screw **5**.

Guideline

Screw, rear wheel speed sensor	M6	6 Nm (4.4 lbf ft)
--------------------------------	----	-------------------

- Operate the foot brake lever repeatedly until the brake linings are in contact with the brake disc and there is a pressure point.

Finishing work

- Check the chain tension. (📖 p. 89)
- Remove the rear of the motorcycle from the lifting gear. (📖 p. 86)

15.5 Checking the rear hub damping rubber pieces 🛠️

i Info

The engine power is transmitted from the rear sprocket to the rear wheel via the 6 damping rubber pieces. They eventually wear out during operation. If the damping rubber pieces are not changed in time, the rear sprocket carrier and the rear hub will be damaged.

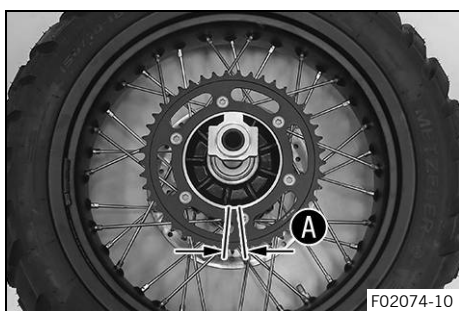

Preparatory work

- Raise motorcycle with rear lifting gear. (📖 p. 86)
- Remove the rear wheel. 🛠️ (📖 p. 117)

Main work

- Check bearing **1**.
 - » If the bearing is damaged or worn:
 - Change the bearing of the rear sprocket carrier. 🛠️
- Check damping rubber pieces **2** of the rear hub for damage and wear.
 - » If the damping rubber pieces of the rear hub are damaged or worn:
 - Change all the damping rubber pieces of the rear hub.
- Lay the rear wheel on a workbench with the rear sprocket facing upwards and insert the wheel spindle in the hub.
- To check play **A**, hold the rear wheel tight and try to turn the rear sprocket with your hand.

i Info

Measure the play on the outside of the rear sprocket.

Play of damping rubber pieces on rear wheel	≤ 5 mm (≤ 0.2 in)
---	-------------------

- » If clearance **A** is larger than the specified value:
 - Change all the damping rubber pieces of the rear hub. 🛠️

Finishing work

- Install the rear wheel. 🛠️ (📖 p. 118)
- Check the chain tension. (📖 p. 89)
- Remove the rear of the motorcycle from the lifting gear. (📖 p. 86)

15.6 Checking the tire condition



Warning

Danger of accidents If a tire bursts while riding, the vehicle becomes uncontrollable.

- Ensure that damaged or worn tires are replaced immediately. (Your authorized KTM workshop will be glad to help.)



Warning

Danger of crashing Different tire tread patterns on the front and rear wheel impair the handling characteristic.

Different tire tread patterns can make the vehicle significantly more difficult to control.

- Make sure that only tires with a similar tire tread pattern are fitted to the front and rear wheel.



Warning

Danger of accidents Non-approved or non-recommended tires and wheels impact the handling characteristic.

- Only use tires/wheels approved by KTM with the corresponding speed index.



Warning

Danger of accidents New tires have reduced road grip.

The contact surface on new tires is not yet roughened.

- Run in new tires with moderate riding at alternating angles.
Running-in phase 200 km (124 mi)



Info

Tire type, tire condition, and tire pressure influence the braking and handling characteristics of the vehicle.

Worn tires have a negative effect on handling characteristics, especially on wet surfaces.

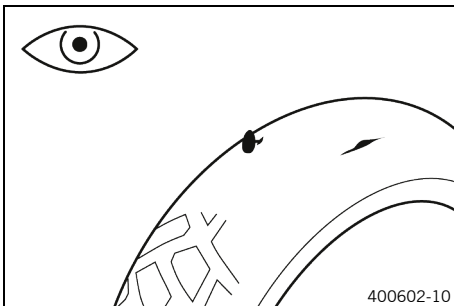

- Check the front and rear tires for cuts, embedded objects, and other damage.
 - » If the tires have cuts, run-in objects, or other damage:
 - Change the tires. 🛠️
- Check the tread depth.



Info

Adhere to the legally required minimum tread depth.

Minimum tread depth	≥ 2 mm (≥ 0.08 in)
---------------------	--------------------

- » If the tread depth is less than the minimum tread depth:
 - Change the tires. 🛠️

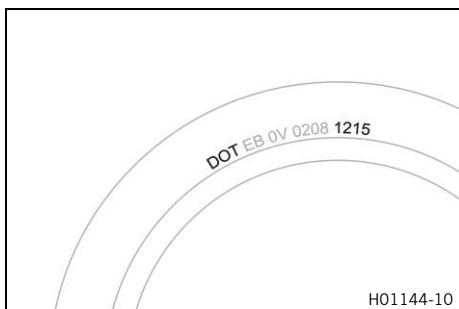

- Check the tire age.



Info

The tire date of manufacture is usually contained in the tire label and is indicated by the last four digits of the **DOT** number. The first two digits indicate the week of manufacture and the last two digits the year of manufacture.

KTM recommends that the tires be changed after 5 years at the latest, regardless of the actual state of wear.

- » If the tires are more than 5 years old:
 - Change the tires. 🛠️

15.7 Checking tire pressure



Info

Low tire pressure leads to abnormal wear and overheating of the tire.

Correct tire pressure ensures optimal riding comfort and maximum tire service life.

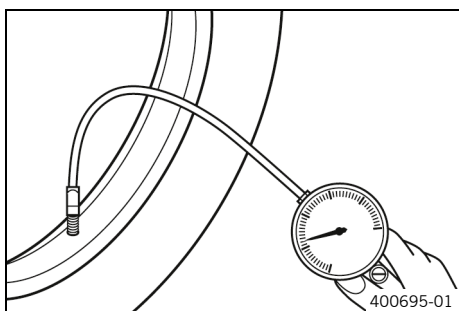

- Remove protection cap.
- Check tire pressure when the tires are cold.

Tire pressure solo / with passenger	
front	2.4 bar (35 psi)
rear	2.4 bar (35 psi)

Offroad tire pressure	
front	1.8 bar (26 psi)
rear	1.8 bar (26 psi)

Tire pressure full payload	
front	2.6 bar (38 psi)
rear	2.9 bar (42 psi)

- » If the tire pressure does not meet specifications:
 - Correct tire pressure.
- Mount the protection cap.

15.8 Checking spoke tension



Warning

Danger of accidents Incorrectly tensioned spokes impair the handling characteristic and result in secondary damage.

The spokes break due to being overloaded if they are too tightly tensioned. If the tension in the spokes is too low, then lateral and radial run-out will form in the wheel. Other spokes will become looser as a result.

- Check spoke tension regularly, and in particular on a new vehicle. (Your authorized KTM workshop will be glad to help.)

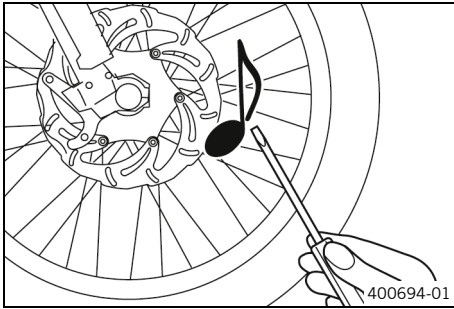

- Strike each spoke briefly using a screwdriver blade.



Info

The frequency of the sound depends on the spoke length and spoke diameter. If spokes of the same length and diameter vibrate with a different tone, this is an indication that the spoke tensions differ.

You should hear a high note.

- » If the spoke tension differs:
 - Correct the spoke tension. ↩



15.9 Tubeless tire system

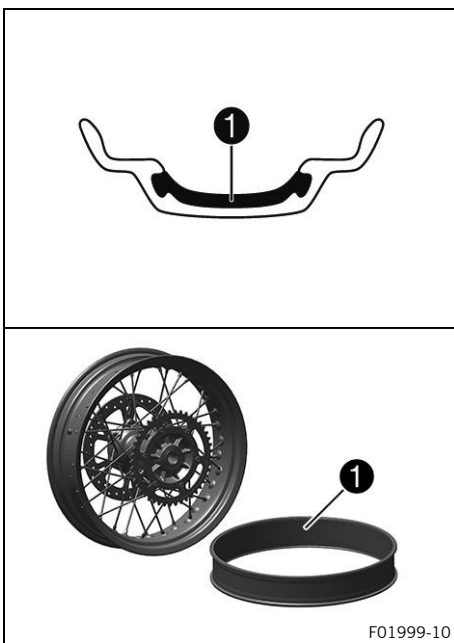

This vehicle uses a tubeless tire system in which a rim seal band ❶ is used instead of the conventional tube.

The advantages of the tubeless system lie in the absence of danger from a faulty tube. This greatly reduces the risk of a sudden loss in pressure.

The moments of inertia of these wheels are smaller than in conventional spoked wheels with a tube. This results in better handling and riding comfort.

The rigid rim design results in a wire spoke wheel that is almost entirely maintenance-free.

KTM recommends that the rim seal band be changed after 5 years at the latest, regardless of the actual state of wear.

15.10 Using tire repair spray

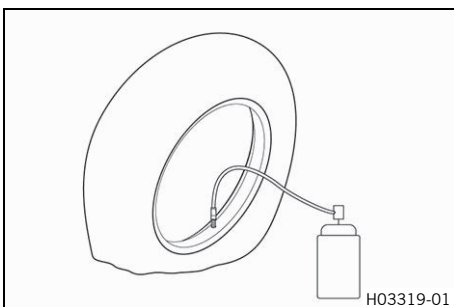

Warning

Danger of accidents Incorrect use of tire repair spray will result in the repaired tire losing pressure.

Tire repair spray cannot be used for all types of damage.

- Observe the instructions and specifications of the manufacturer of the tire repair spray.
- After repairing a tire with tire repair spray, ride slowly and carefully.
- Ride no further than to the nearest workshop and have the tire changed.

Tire repair spray should only be used in an emergency. We recommend transporting the broken down vehicle to the nearest workshop instead of using tire repair spray.

(Option: With TPMS)

Note

Material damage Tire repair spray damages the tire pressure sensor.

- Note that after using tire repair spray, the tire pressure sensor may need to be replaced.
-

16.1 Daytime running light (DRL)

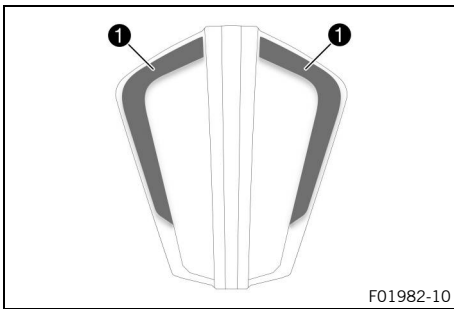

Warning

Danger of accidents When visibility is poor, the daytime running light is not a substitute for the low beam.

Automatic switching between the daytime running light and low beam may only be partially available when visibility is significantly impaired due to fog, snow or rain.

- Ensure that the appropriate type of lighting is always selected.
- If necessary switch off the daytime running lights using the menu before going on a ride or when stopped so that the low beam is switched on permanently.
- Make sure that the daytime running light is deactivated with the diagnostics tool when the menu item is not available, but the low beam is required. (Your authorized KTM workshop will be glad to help.)
- Note the legal regulations regarding the daytime running light.

The daytime running light (DRL) is integrated in the main headlight.

The daytime running light (DRL) must only be switched on when visibility conditions are good.

The daytime running light (DRL) is activated in the combination instrument.

This is controlled by the ambient light sensor in the combination instrument. When visibility conditions are good, the low beam is switched off and the daytime running light is switched on.



Info

The position light **1** lights up with all types of lighting.

16.2 Removing the 12-V battery ↗



Warning

Risk of injury Battery acid and battery gases cause serious chemical burns.

- Keep 12 V batteries out of the reach of children.
- Wear suitable protective clothing and safety glasses.
- Avoid contact with battery acid and battery gases.
- Keep sparks or open flames away from the 12 V battery.
- Only charge 12 V batteries in well-ventilated rooms.
- Rinse the affected area immediately with plenty of water in the event of contact with the skin.
- Rinse eyes with water for at least 15 minutes and consult a doctor immediately if battery acid and battery gases get into the eyes.



Caution

Danger of accidents Electronic components and safety devices will be damaged if the 12-V battery is discharged or missing.

If the 12-V battery is discharged or defective, malfunctions in the vehicle electronics can occur, especially when starting.

- Never operate the vehicle with a discharged 12-V battery or without a 12-V battery.

Preparatory work

- Remove the seat. (📖 p. 87)
- Remove the battery cover. (📖 p. 94)

Main work

- Pull the diagnostics connector **1** out of the bracket and hang to the side.
- Remove screw **2**.
- Raise the battery mounting element **3** at the rear and remove in upward direction.

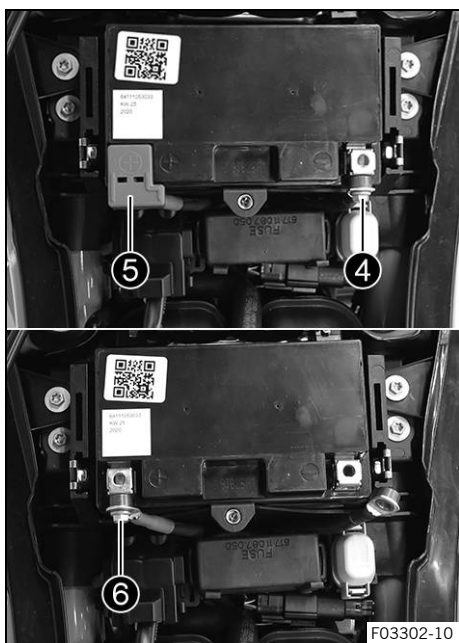
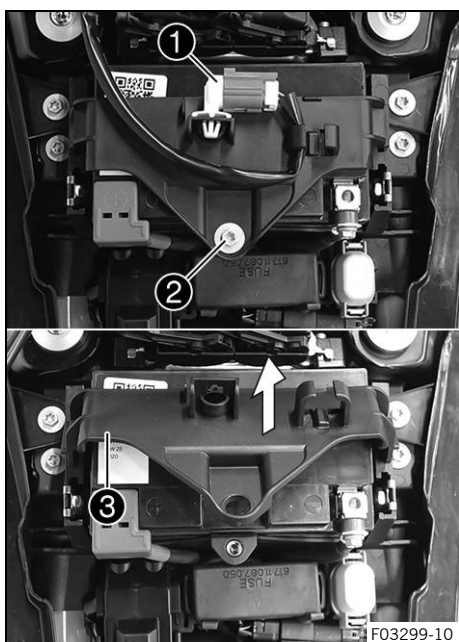

- Disconnect negative cable **4** from the 12-V battery.
- Remove positive terminal cover **5**.
- Disconnect positive cable **6** from the 12-V battery.
- Pull the 12-V battery upwards and out of the battery compartment.

16.3 Installing the 12-V battery ↻



Warning

Risk of injury Battery acid and battery gases cause serious chemical burns.

- Keep 12 V batteries out of the reach of children.
- Wear suitable protective clothing and safety glasses.
- Avoid contact with battery acid and battery gases.
- Keep sparks or open flames away from the 12 V battery.
- Only charge 12 V batteries in well-ventilated rooms.
- Rinse the affected area immediately with plenty of water in the event of contact with the skin.
- Rinse eyes with water for at least 15 minutes and consult a doctor immediately if battery acid and battery gases get into the eyes.



Caution

Danger of accidents Electronic components and safety devices will be damaged if the 12-V battery is discharged or missing.

If the 12-V battery is discharged or defective, malfunctions in the vehicle electronics can occur, especially when starting.

- Never operate the vehicle with a discharged 12-V battery or without a 12-V battery.

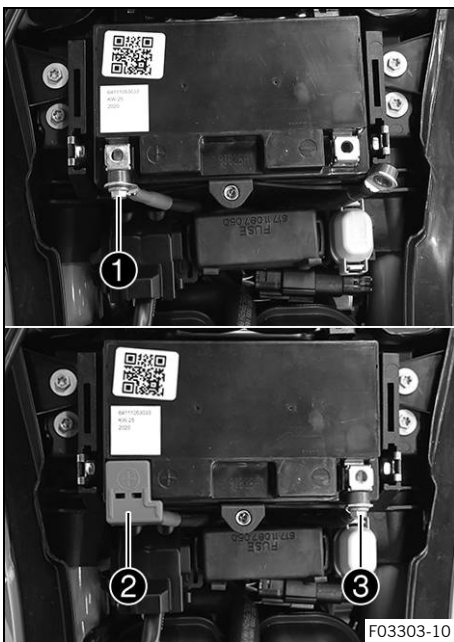

Main work

- Position the 12-V battery in the battery compartment.

12-V battery (HTZ12A-BS) (📖 p. 155)

- ✓ The battery terminals face opposite the direction of travel.

- Connect positive cable ① to the 12-V battery.

Guideline

Screw, battery terminal	M6	4.5 Nm (3.32 lbf ft)
-------------------------	----	-------------------------

- Mount positive terminal cover ②.

- Connect negative cable ③ to the 12 V battery.

Guideline

Screw, battery terminal	M6	4.5 Nm (3.32 lbf ft)
-------------------------	----	-------------------------

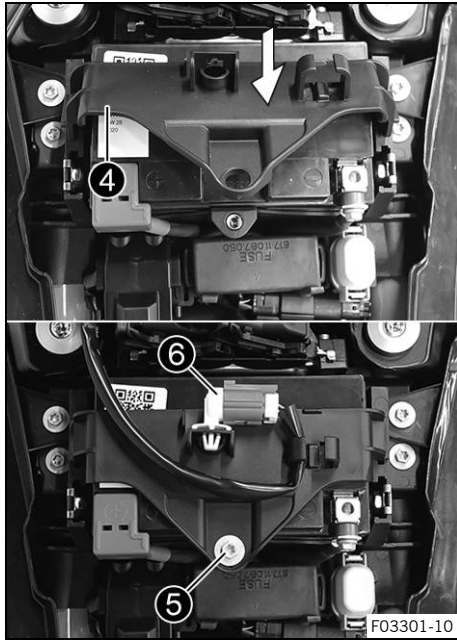

- Hang battery mounting bracket **4** to the left and right in the holding lugs and push downward at the back.
- Mount and tighten screw **5**.

Guideline

Screw, battery support bracket	M6	5 Nm (3.7 lbf ft)
--------------------------------	----	-------------------

- Position the diagnostics connector **6** in the holder.

Finishing work

- Install the battery cover. (📖 p. 95)
- Mount the seat. (📖 p. 87)
- Set time and date.

16.4 Charging the 12-V battery ↗



Warning

Risk of injury Battery acid and battery gases cause serious chemical burns.

- Keep 12 V batteries out of the reach of children.
- Wear suitable protective clothing and safety glasses.
- Avoid contact with battery acid and battery gases.
- Keep sparks or open flames away from the 12 V battery.
- Only charge 12 V batteries in well-ventilated rooms.
- Rinse the affected area immediately with plenty of water in the event of contact with the skin.
- Rinse eyes with water for at least 15 minutes and consult a doctor immediately if battery acid and battery gases get into the eyes.



Note

Environmental hazard 12 V batteries contain environmentally hazardous materials.

- Do not dispose of 12 V batteries as household waste.
- Dispose of 12 V batteries at a collection point for used batteries.



Note

Environmental hazard Hazardous substances cause environmental damage.

- Dispose of oils, grease, filters, fuel, cleaning agents, brake fluid, etc., correctly and in compliance with the applicable regulations.

i Info

Even when there is no load on the 12-V battery, it discharges steadily each day. The charging level and the method of charging are very important for the service life of the 12-V battery. Rapid recharging with a high charging current shortens the service life of the battery. If the charging current, charging voltage, or charging time is exceeded, electrolyte escapes through the safety valves. This reduces the capacity of the 12-V battery. If the 12-V battery is depleted from starting the vehicle repeatedly, the battery must be charged immediately. If the 12-V battery is left in a discharged state for an extended period, it will become deeply discharged and sulfating occurs, destroying the battery. The 12-V battery is maintenance-free. The acid level does not have to be checked.

Preparatory work

- Remove the seat. (📖 p. 87)
- Remove the battery cover. (📖 p. 94)

Main work

- Disconnect negative cable **1** from the 12 V battery to avoid damaging the onboard electronics.
- Remove positive terminal cover **2**.

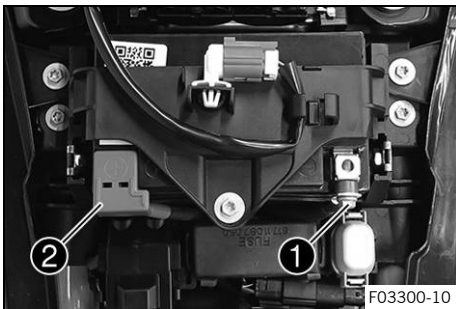

F03300-10

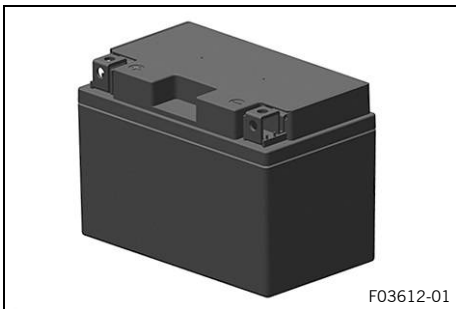

F03612-01

- Connect a battery charger to the 12-V battery. Connect the battery charger to the mains connection.

Battery charger (58429074200)

It is impossible to overcharge the 12-V battery using this battery charger.

This battery charger is not suitable for lithium-ion batteries.

i Info

Charge the 12-V battery to a maximum of 10 % of the capacity specified on the battery housing.

- Disconnect the battery charger from the mains connection and the 12-V battery after charging.

Guideline

The charging current, charging voltage, and charging time must not be exceeded.	
---	--

Recharge the 12-V battery regularly when the motorcycle is not being used	3 months
---	----------

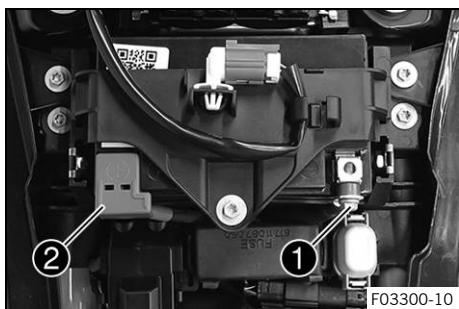

- Mount positive terminal cover ②.
- Connect negative cable ① to the 12 V battery.

Guideline

Screw, battery terminal	M6	4.5 Nm (3.32 lbf ft)
-------------------------	----	-------------------------

Finishing work

- Install the battery cover. (📖 p. 95)
- Mount the seat. (📖 p. 87)
- Set time and date.

16.5 Changing the main fuse



Warning

Fire hazard Incorrect fuses overload the electrical system.

- Only use fuses with the required ampere value.
- Do not bypass or repair fuses.



Info

The main fuse protects all electrical power consumers of the vehicle. The main fuse is under the seat.

Preparatory work

- Remove the seat. (📖 p. 87)

Main work

- Remove protection cap ①.

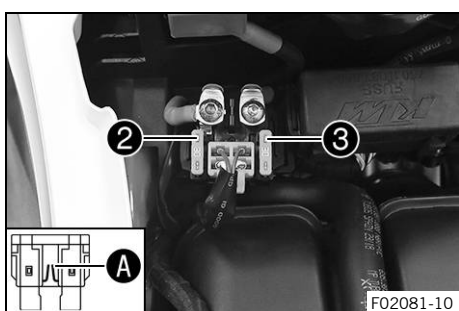
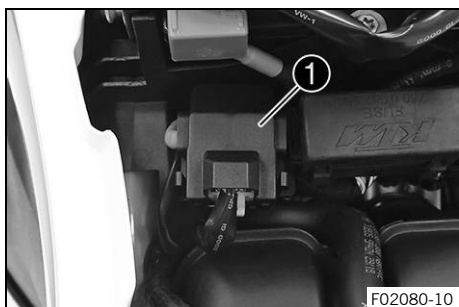

- Remove faulty main fuse ②.

Info

A faulty fuse has a burned-out fuse wire **A**.
A spare fuse ③ is located in the starter relay.

- Insert a new main fuse.

Fuse (58011109130) (📖 p. 155)

Tip

Insert a new spare fuse into the starter relay to have it available when needed.

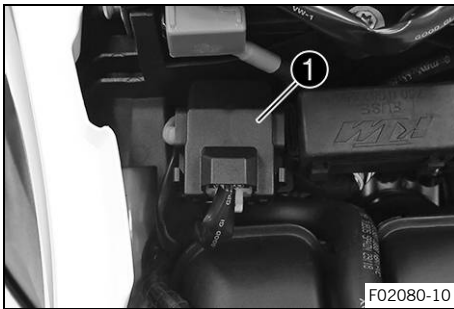

- Mount protection cap ①.

Finishing work

- Mount the seat. (📖 p. 87)
- Set time and date.



16.6 Changing the ABS fuses



Warning

Fire hazard Incorrect fuses overload the electrical system.

- Only use fuses with the required ampere value.
- Do not bypass or repair fuses.



Info

Two fuses for the ABS are located under the seat. These fuses protect the return pump and the hydraulic unit of the ABS. The third fuse, which protects the ABS control unit, is located in the fuse box.

Preparatory work

- Remove the seat. (📖 p. 87)

To change the fuse of the ABS hydraulic unit:

- Remove the protection cap and fuse ①.



Info

A faulty fuse has a burned-out fuse wire **A**.

- Insert the spare fuse with the correct rating.

Fuse (75011088010) (📖 p. 155)



Tip

Insert spare fuse ② in the fuse box so that it is available if needed.

- Mount the protection cap.

To change the fuse of the ABS return pump:

- Remove the protection cap and fuse ③.



Info

A faulty fuse has a burned-out fuse wire **A**.

- Insert the spare fuse with the correct rating.

Fuse (75011088025) (📖 p. 155)

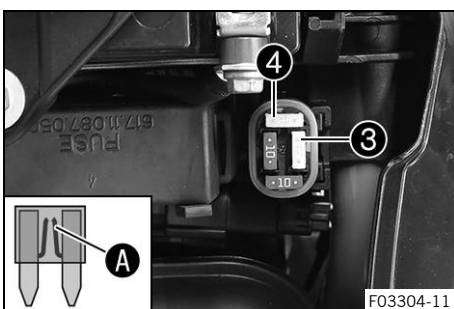
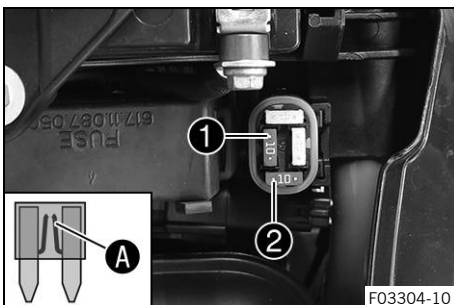

i Tip
 Insert spare fuse ④ in the fuse box so that it is available if needed.

- Mount the protection cap.

Finishing work

- Mount the seat. (📖 p. 87)

16.7 Changing the fuses of individual electrical power consumers



Warning

Fire hazard Incorrect fuses overload the electrical system.

- Only use fuses with the required ampere value.
- Do not bypass or repair fuses.



Info

The fuse box containing the fuses of individual electrical power consumers is located under the seat.

Preparatory work

- Remove the seat. (📖 p. 87)

Main work

- Open fuse box cover ①.

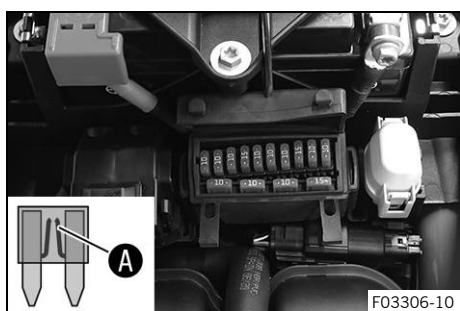
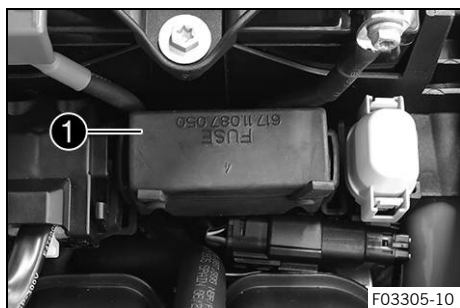

- Remove the faulty fuse.

Guideline

Fuse 1 - 10 A - ignition, alarm system (optional)
Fuse 2 - 10 A - ignition, engine control unit, electronic fuel injection, fuel vapor retention system, lambda sensor, immobilizer
Fuse 3 - 10 A - fuel pump
Fuse 4 - 15 A - radiator fan
Fuse 5 - 10 A - horn, combination instrument, brake light
Fuse 6 - 10 A - high beam, low beam, position light, tail light, license plate lamp
Fuse 7 - 10 A - ACC1
Fuse 8 - 15 A - ACC2, HCU (optional)
Fuse 9 - 10 A - ABS control unit, diagnostics connector, 5D sensor, TPMS (function optional)
Fuse 10 - 10 A - light control unit
Fuse SPARE - 10 A - spare fuses
Fuse SPARE - 15 A - spare fuses

**Info**

A faulty fuse has a burned-out fuse wire **A**.

- Insert the spare fuse with the correct rating.

Fuse (75011088010) (📖 p. 155)

Fuse (75011088015) (📖 p. 155)

**Tip**

Put a spare fuse in the fuse box so that it is available if needed.

- Check the function of the electrical power consumers.
- Close the fuse box cover.

Finishing work

- Mount the seat. (📖 p. 87)

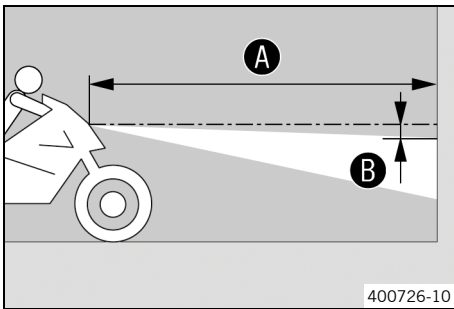
**16.8 Checking the headlight setting**

- Park the vehicle on a horizontal surface in front of a light-colored wall and make a mark at the height of the center of the low beam headlight.
- Make another mark at a distance **B** under the first marking.

Guideline

Distance B	5 cm (2 in)
-------------------	-------------

- Position the vehicle upright at distance **A** from the wall and switch on the low beam.

Guideline

Distance A	5 m (16 ft)
-------------------	-------------

- The rider now mounts the motorcycle with luggage and passenger if applicable.
- Check the headlight setting.

The light-dark boundary must be exactly on the lower marking when the motorcycle is ready to be operated with the rider mounted along with any luggage and a passenger if applicable.

- » If the boundary between light and dark does not meet specifications:

- Adjust headlight range. (📖 p. 134)



16.9 Adjusting the headlight range

Preparatory work

- Check the headlight setting. (📖 p. 133)

Main work

- Remove screws ①.
- Remove the left mask spoiler.

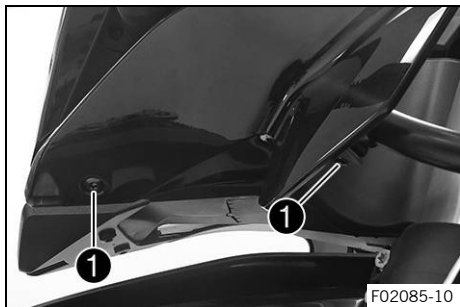

- Turn adjusting screw ② to adjust the headlight range.



i Info

Turn clockwise to reduce the headlight range; turn counterclockwise to increase the headlight range. If you have a payload, you may have to correct the headlight range.

- Set the headlight to marking **B**.

Guideline

The light-dark boundary must lie exactly on lower marking **B** when the motorcycle is ready to operate with the rider mounted along with any luggage and a passenger, if applicable.

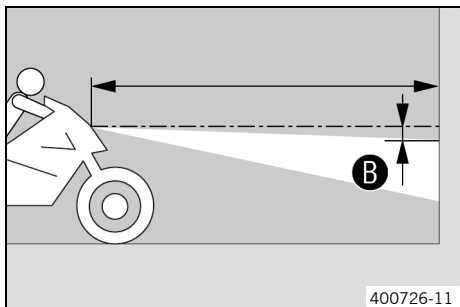

- Position left mask spoiler.
- Mount and tighten screws ①.

Guideline

Remaining screws, chassis	M5	5 Nm (3.7 lbf ft)
---------------------------	----	-------------------

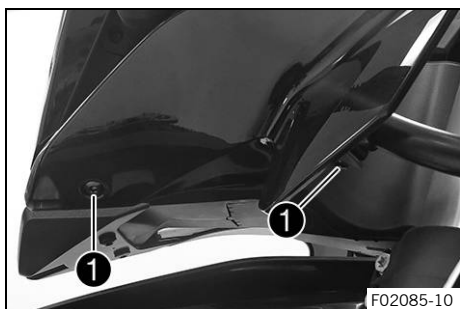

16.10 Diagnostics connector

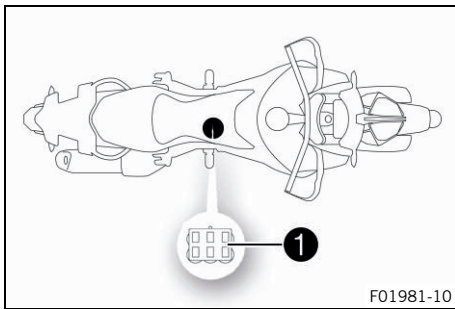

Diagnostics connector ① is located under the battery cover.

16.11 Front ACC1 and ACC2

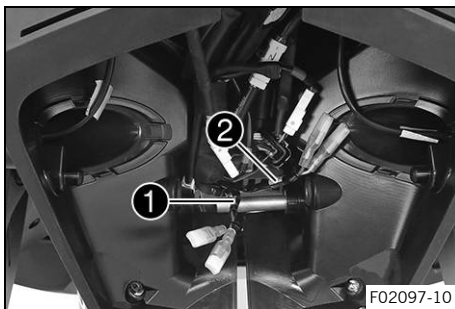

Installation location

- The front power supplies ACC1 ① and ACC2 ② are located behind the headlight.

i Info

The front power supplies ACC1 and ACC2 can be accessed under the cable cover of the headlight mask.

16.12 ACC1 and ACC2 rear

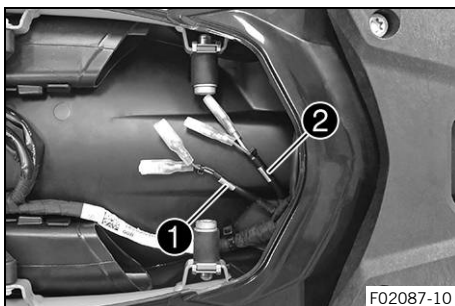

Installation location

- Power supplies ACC1 ① and ACC2 ② rear are located under the seat.

17.1 Cooling system

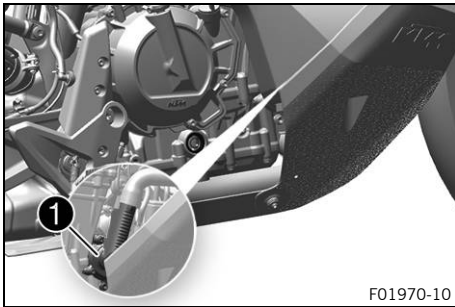

Water pump **1** in the engine ensures forced circulation of the coolant.

The pressure resulting from the warming of the cooling system is regulated by a valve in radiator cap **2**. Heat expansion causes excess coolant to flow into compensating tank **3**. When the temperature falls, this surplus coolant is sucked back into the cooling system. This ensures that operating the vehicle at the specified coolant temperature will not result in a risk of malfunctions.

115 °C (239 °F)

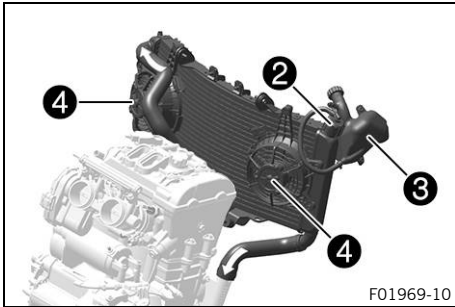

The coolant is cooled by the air stream and two radiator fans **4**, which are activated at high temperature.

The lower the speed, the less the cooling effect. Dirty cooling fins also reduce the cooling effect.

17.2 Checking the coolant level in the compensating tank



Warning

Danger of scalding During motorcycle operation, the coolant gets very hot and is under pressure.

- Do not open the radiator, the radiator hoses or other cooling system components if the engine or the cooling system are at operating temperature.
- Allow the cooling system and the engine to cool down before you open the radiator, the radiator hoses or other components of the cooling system.
- In the event of scalding, rinse the area affected immediately with lukewarm water.



Warning

Danger of poisoning Coolant is toxic and a health hazard.

- Keep coolant out of the reach of children.
- Do not allow coolant to come into contact with the skin, the eyes and clothing.
- Consult a doctor immediately if coolant is swallowed.
- Rinse the affected area immediately with plenty of water in the event of contact with the skin.
- Rinse eyes thoroughly with water and consult a doctor immediately if coolant gets into the eyes.
- Change clothing if coolant spills onto your clothing.

Condition

The engine is cold.

The radiator is completely full.

- Park the motorcycle on a horizontal surface.

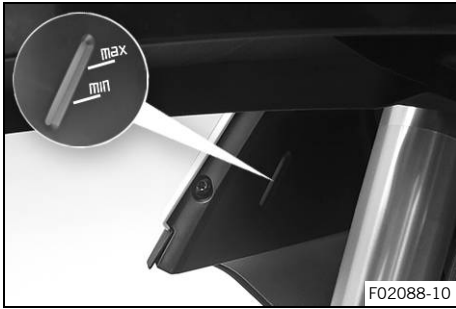

- Check the coolant level in the compensating tank.

The coolant level must be between **MIN** and **MAX**.

- » If there is no coolant in the compensating tank:
 - Check the cooling system for leaks. 🛠️

i Info

Do not start up the motorcycle!

- Fill/bleed the cooling system. 🛠️
- » If the coolant level in the compensating tank is not at the required level, but the tank is not empty:
 - Correct the coolant level in the compensating tank. (📖 p. 137)



17.3 Correcting the coolant level in the compensating tank



Warning

Danger of scalding During motorcycle operation, the coolant gets very hot and is under pressure.

- Do not open the radiator, the radiator hoses or other cooling system components if the engine or the cooling system are at operating temperature.
- Allow the cooling system and the engine to cool down before you open the radiator, the radiator hoses or other components of the cooling system.
- In the event of scalding, rinse the area affected immediately with lukewarm water.



Warning

Danger of poisoning Coolant is toxic and a health hazard.

- Keep coolant out of the reach of children.
- Do not allow coolant to come into contact with the skin, the eyes and clothing.
- Consult a doctor immediately if coolant is swallowed.
- Rinse the affected area immediately with plenty of water in the event of contact with the skin.
- Rinse eyes thoroughly with water and consult a doctor immediately if coolant gets into the eyes.
- Change clothing if coolant spills onto your clothing.

Condition

The engine is cold.
The radiator is completely full.

Preparatory work

- Check the coolant level in the compensating tank. (📖 p. 136)

Main work

- Remove cover ❶ of the compensating tank.

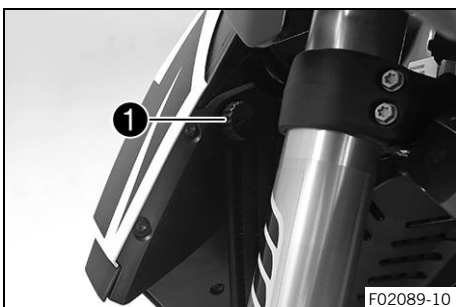

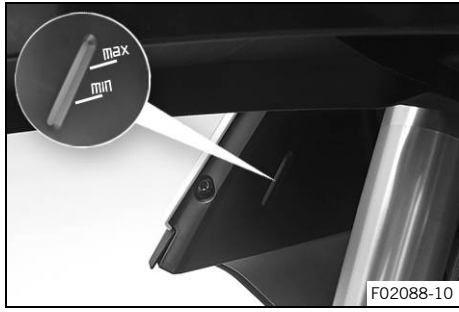

- Add coolant until the coolant reaches the specified level.

Guideline

The coolant level must be between **MIN** and **MAX**.

Coolant (📖 p. 163)

- Mount cover **1** of the compensating tank.

Guideline

Compensating tank cover	-	1.1 Nm (0.81 lbf ft)
-------------------------	---	-------------------------

18.1 Ride Mode

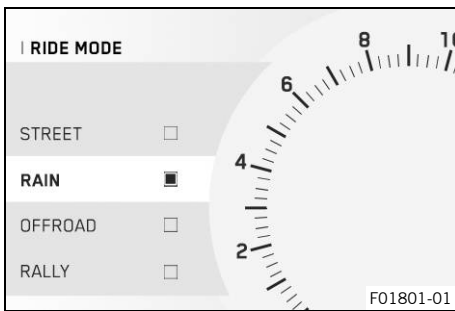

Possible states

- Street – Homologated performance with balanced response; the motorcycle traction control allows normal slip on the rear wheel. The Anti-Wheelie mode is active.
- Rain – Reduced homologated performance for better rideability; the motorcycle traction control allows less slip on the rear wheel. The Anti-Wheelie mode is active.
- Offroad – Reduced homologated performance for better rideability; the motorcycle traction control allows increased slip on the rear wheel. The Anti-Wheelie mode is deactivated.
- Rally (optional) – Setting with homologated performance and extremely direct response. The motorcycle traction control and the characteristic map of the throttle response can be individually set. The Anti-Wheelie mode is deactivated.



Warning

Danger of accidents An incorrectly selected riding mode makes control of the vehicle considerably more difficult.

The riding modes are each only suitable for certain conditions.

- Always select a riding mode that suits the surface on which you are riding, the weather and the riding situation.

Various vehicle tunings can be selected in the combination instrument in the **Ride Mode** submenu. **Street**, **Rain**, **Offroad** and **Rally** are available (optional).

The riding mode selected last appears in the display.

The drive mode can also be changed while riding with a closed throttle grip.



Info

The riding mode selection does not influence the ABS.

18.2 Motorcycle traction control (Cornering MTC)

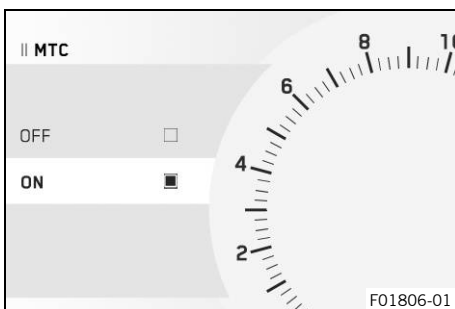

The motorcycle traction control (MTC) lowers the engine torque in case of loss of traction in the rear wheel. Depending on the riding mode (p. 139), different amounts of slip are allowed when traction control is activated.





Info

When motorcycle traction control is switched off, the rear wheel may spin during strong acceleration and on surfaces with low grip, resulting in a risk of falling.

After the ignition is switched on, motorcycle traction control is enabled again.

In the combination instrument, the motorcycle traction control can be switched on or off via the **MTC** submenu.

i Info

When the motorcycle traction control is active, the TC indicator lamp  flashes.
When motorcycle traction control is switched off, the TC indicator lamp  lights up.

18.3 Slip adjustment (optional)

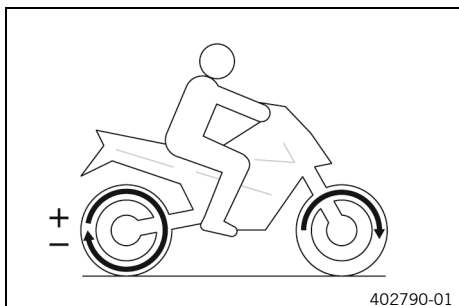

The slip adjustment is a motorcycle traction control function. The slip adjustment allows the motorcycle traction control to be tuned through nine levels to the desired characteristic map. Level 1 allows the maximum slip on the rear wheel, and level 9 the minimum.

The slip adjustment can be set while riding with a closed menu using the **UP** or **DOWN** button.

i Info

The slip adjustment is only available in drive mode **Rally** (optional).

18.4 Throttle Response (optional)

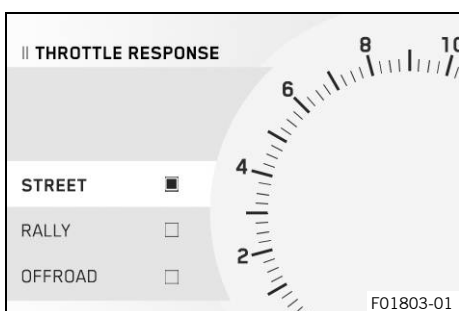

Possible states

- Street – Balanced response.
- Rally – Extremely direct response
- Offroad – Very direct response.

In the combination instrument, the characteristics of the throttle response can be adjusted via the **Throttle response** submenu. The **Throttle response** can also be set while riding with a closed throttle grip.

i Info

Throttle response is only available in drive mode **Rally** (optional).

19.1 Checking the engine oil level

i Info

The engine oil level must be checked at normal engine operating temperature.

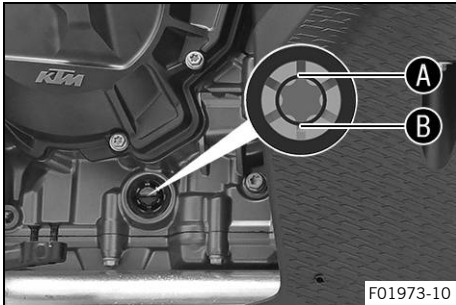

- Stand motorcycle upright on a horizontal surface.
- Check the engine oil level.

i Info

After switching off the engine, wait one minute before checking the level.

The engine oil must be between marking **A** and marking **B** of the oil level viewer.

- » If the engine oil level is below the marking **B**:
 - Add engine oil. (📖 p. 143)
- » If the engine oil level is above the marking **A**:
 - Correct engine oil level.



19.2 Changing the engine oil and oil filter, cleaning the oil screens



Warning

Danger of scalding Engine and gear oil get very hot when the motorcycle is ridden.

- Wear suitable protective clothing and safety gloves.
- In the event of scalding, rinse the area affected immediately with lukewarm water.



Note

Environmental hazard Hazardous substances cause environmental damage.

- Dispose of oils, grease, filters, fuel, cleaning agents, brake fluid, etc., correctly and in compliance with the applicable regulations.

i Info

Drain the engine oil while the engine is at operating temperature.

Preparatory work

- Remove engine guard. (📖 p. 104)

Main work

- Rest the motorcycle on its side stand on a horizontal surface.
- Position an appropriate container under the engine.
- Remove filler plug **1** with the O-ring.

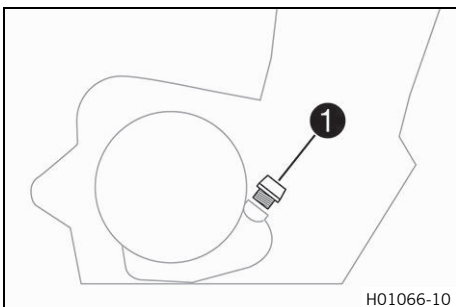

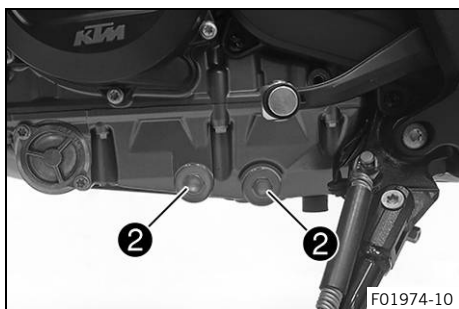

- Remove oil drain plugs **2** along with the magnets, the O-rings, and the oil screens.

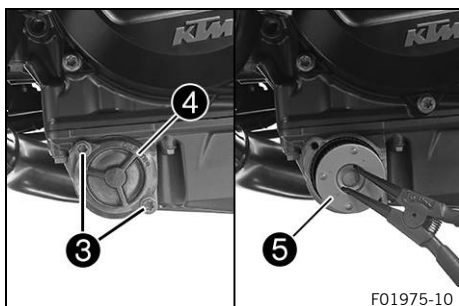

- Remove screws **3**. Take off oil filter cover **4** with the O-ring.
- Pull oil filter **5** out of the oil filter housing.

Lock ring plier (51012011000)

- Allow the engine oil to drain completely.
- Thoroughly clean the parts and the sealing surfaces.

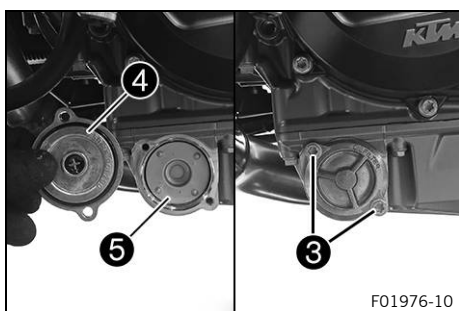

- Insert new oil filter **5**.

i Info
Only insert the oil filter by hand.

- Oil the new O-ring of the oil filter cover. Position oil filter cover **4**.
- Mount and tighten screws **3**.

Guideline

Screw, oil filter cover	M5	6 Nm (4.4 lbf ft)
-------------------------	----	-------------------

- Thoroughly clean magnets **A** and oil screens **B** of the oil drain plugs.

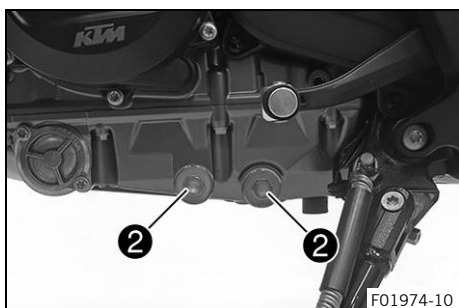
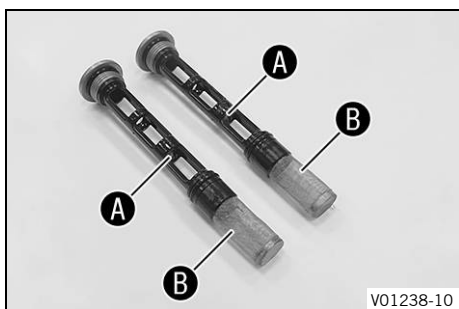

- Mount the oil drain plugs **2** with magnets and new seal rings, and tighten.

Guideline

Plug, oil screen	M20x1.5	20 Nm (14.8 lbf ft)
------------------	---------	---------------------

- Fill up with engine oil at the clutch cover.

Engine oil	2.8 l (3 qt.)	Engine oil (SAE 10W/50) (p. 163)
------------	---------------	----------------------------------

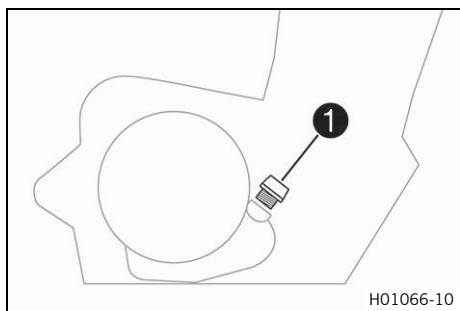

- Mount and tighten filler plug ① with the O-ring.



Danger

Danger of poisoning Exhaust gases are toxic and inhaling them may result in unconsciousness and death.

- Always make sure there is sufficient ventilation when running the engine.
- Use effective exhaust extraction when starting or running the engine in an enclosed space.

- Start the engine and check it for leaks.

Finishing work

- Check the engine oil level. (📖 p. 141)
- Install the engine guard. (📖 p. 105)



19.3 Adding engine oil



Info

Too little engine oil or poor-quality engine oil will result in premature wear of the engine.

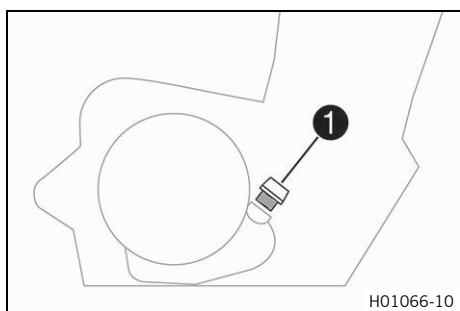

Main work

- Remove filler plug ① with the O-ring.
- Fill engine oil to the middle of the level viewer.

Engine oil (SAE 10W/50) (📖 p. 163)



Info

In order to achieve optimal engine oil performance, it is not advisable to mix different engine oils. KTM recommends changing the engine oil where necessary.

- Mount and tighten filler plug ① with the O-ring.



Danger

Danger of poisoning Exhaust gases are toxic and inhaling them may result in unconsciousness and death.

- Always make sure there is sufficient ventilation when running the engine.
- Use effective exhaust extraction when starting or running the engine in an enclosed space.

- Start the engine and check for leaks.

Finishing work

- Check the engine oil level. (📖 p. 141)



19.4 Checking the free travel of the clutch lever

Note

Clutch damage If there is no free travel by the clutch lever, the clutch will begin to slip.

- Check the free travel of the clutch lever each time before using the motorcycle.
- Adjust the free travel of the clutch lever when necessary in accordance with the specification.

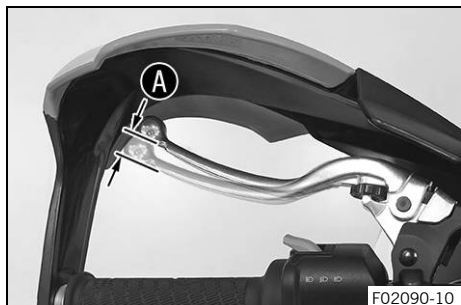

- Check the clutch lever for smooth operation.
- Move the handlebar to the straight-ahead position.
- Pull the clutch lever until resistance is perceptible, and determine the free travel **A**.

Free travel A of clutch lever	5 mm (0.2 in)
--------------------------------------	---------------

- » If the free travel of the clutch lever does not meet specifications:
 - Set the free travel of the clutch lever. 🛠️ (p. 144)
- Move the handlebar to and fro over the entire steering range.

The free travel of the clutch lever must not change.

- » If the free travel of the clutch lever changes:
 - Check the routing of the clutch cable.

19.5 Setting the free travel of the clutch lever 🛠️

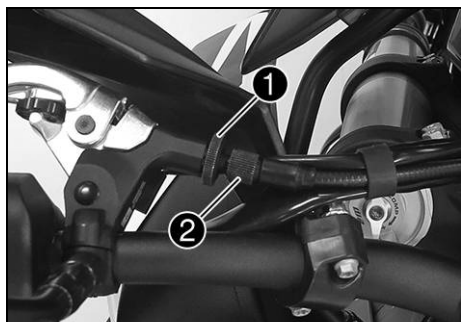

- Move the handlebar to the straight-ahead position.
- Loosen lock nut **1**.
- Adjust the free travel **A** by turning adjusting screw **2**.

Guideline

Free travel A of clutch lever	5 mm (0.2 in)
--------------------------------------	---------------

- Tighten lock nut **1**.



20.1 Cleaning the motorcycle

Note

Material damage Components become damaged or destroyed if a pressure cleaner is used incorrectly. The high pressure forces water into the electrical components, connectors, throttle cables, and bearings, etc. Pressure which is too high causes malfunctions and destroys components.

- Do not direct the water jet directly on to electrical components, connectors, throttle cables or bearings.
- Maintain a minimum distance between the nozzle of the pressure cleaner and the component.
Minimum clearance 60 cm (23.6 in)



Note

Environmental hazard Hazardous substances cause environmental damage.

- Dispose of oils, grease, filters, fuel, cleaning agents, brake fluid, etc., correctly and in compliance with the applicable regulations.



Info

To maintain the value and appearance of the motorcycle over a long period, clean it regularly. Avoid direct sunshine when cleaning the motorcycle.

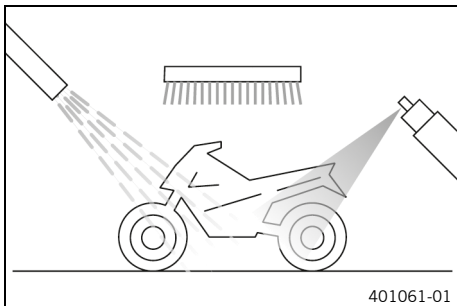

- Close off exhaust system to keep water from entering.
- Remove loose dirt first with a soft jet of water.
- Spray the heavily soiled parts with a normal commercial motorcycle cleaner and clean using a brush.

Motorcycle cleaner (📖 p. 165)



Info

Use warm water containing normal motorcycle cleaner and a soft sponge. Never apply motorcycle cleaner to a dry vehicle; always rinse the vehicle with water first. If the vehicle was operated in road salt, clean it with cold water. Warm water would enhance the corrosive effects of salt.

- After rinsing the motorcycle with a gentle spray of water, allow it to dry thoroughly.
- Remove the closure of the exhaust system.



Warning

Danger of accidents Moisture and dirt impair the brake system.

- Brake carefully several times to dry out and remove dirt from the brake linings and the brake discs.

- After cleaning, ride the vehicle a short distance until the engine warms up.



Info

The heat produced causes water at inaccessible locations in the engine and on the brake system to evaporate.

- After the motorcycle has cooled down, lubricate all moving parts and pivot points.
- Clean the chain. (📖 p. 88)
- Treat bare metal (except for brake discs and the exhaust system) with a corrosion inhibitor.

Preserving materials for paints, metal and rubber (📖 p. 165)

- Treat the painted parts with a mild paint polish.

Perfect finish and high gloss polish for paints (📖 p. 165)

i Info

Do not polish parts that were matte when delivered as this would strongly impair the material quality.

- Treat the plastic parts and powder-coated parts with a mild cleaning and care product.

Special cleaner for glossy and matte paint finishes, metal and plastic surfaces (📖 p. 165)

- Oil the ignition and steering lock, tank lock, and seat lock.

Universal oil spray (📖 p. 165)

20.2 Checks and maintenance steps for winter operation

i Info

If you use the motorcycle in winter, salt can be expected on the roads. You should therefore take precautions against aggressive road salt.

After riding on salted roads, thoroughly clean the vehicle with cold water and dry it well. Warm water enhances the corrosive effects of salt.

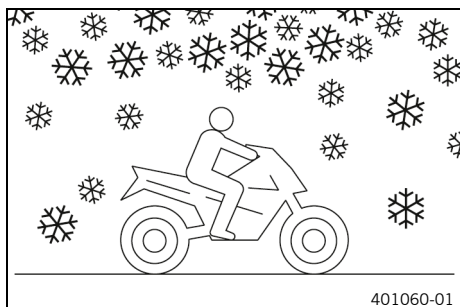

- Clean the motorcycle. (📖 p. 145)
- Clean brake system.

i Info

After **EVERY** trip on salted roads, thoroughly clean the brake calipers and brake linings, after they have cooled down and without removing them, with cold water and dry them carefully.

After riding on salted roads, thoroughly clean the motorcycle with cold water and dry it well.

- Treat engine, link fork, and all other bare or zinc-plated parts (except the brake discs) with a wax-based corrosion inhibitor.

i Info

Corrosion inhibitor must not come in contact with the brake discs as this would greatly reduce the braking force.

- Clean the chain. (📖 p. 88)

21.1 Storage

i Info

If you plan to garage the motorcycle for a longer period, perform the following steps or have them performed.

Before storing the motorcycle, check all parts for function and wear. If service, repairs, or replacements are necessary, you should do this during the storage period (less workshop overload). In this way, you can avoid long workshop waiting times at the start of the new season.

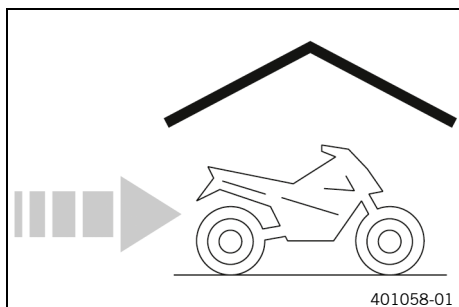

- When refueling for the last time before taking the motorcycle out of service, add fuel additive.

Fuel additive (📖 p. 165)

- Refuel. (📖 p. 76)
- Clean the motorcycle. (📖 p. 145)
- Change the engine oil and the oil filter, clean the oil screens. 🛠️ (📖 p. 141)
- Check the coolant fill level and antifreeze. 🛠️
- Check tire pressure. (📖 p. 122)
- Remove the 12-V battery. 🛠️ (📖 p. 125)

Guideline

Storage temperature of the 12-V battery without direct sunlight	0 ... 35 °C (32 ... 95 °F)
---	----------------------------

- Charge the 12-V battery. 🛠️ (📖 p. 128)
- Store the vehicle in a dry location that is not subject to large fluctuations in temperature.
- Cover the motorcycle with a tarp or cover that is permeable to air.

i Info

Do not use non-porous materials since they prevent humidity from escaping, thus causing corrosion. Avoid running the engine for a short time only. Since the engine cannot warm up properly, the water vapor produced during combustion condenses and causes valves and the exhaust system to rust.



21.2 Preparing for use after storage

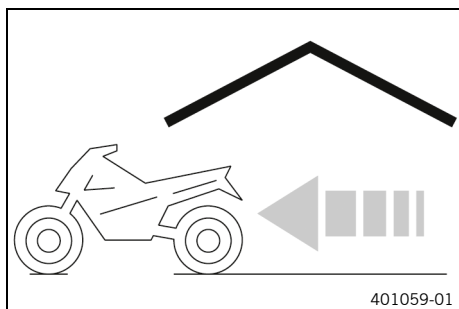

- Take the motorcycle off the front lifting gear. (📖 p. 87)
- Remove the rear of the motorcycle from the lifting gear. (📖 p. 86)
- Install the 12-V battery. 🛠️ (📖 p. 127)
- Set the time and date.
- Perform checks and maintenance measures when preparing for use. (📖 p. 68)
- Take a test ride.



Faults	Possible cause	Action
The engine does not turn when the start button is pressed	Operating error	– Carry out start procedure. (📖 p. 68)
	12-V battery discharged	– Charge the 12-V battery. 🛠️ (📖 p. 128) – Check the open-circuit current. 🛠️
	Fuse 1 , 2 or 3 blown	– Change the fuses of individual electrical power consumers. (📖 p. 132)
	Main fuse burned out	– Change the main fuse. (📖 p. 130)
	No ground connection present	– Check the ground connection.
The engine only turns if the clutch lever is drawn	The vehicle is in gear	– Shift the transmission into neutral N .
	The vehicle is in gear and the side stand is folded out	– Shift the transmission into neutral N .
The engine turns but does not start	Operating error	– Carry out start procedure. (📖 p. 68)
	Fuse 3 blown	– Change the fuses of individual electrical power consumers. (📖 p. 132)
	Quick release coupling not joined	– Join quick release coupling.
	Malfunction in the electronic fuel injection	– Read out the fault memory using the KTM diagnostics tool. 🛠️
	Throttle opened while starting	– When starting, DO NOT open the throttle. – Carry out start procedure. (📖 p. 68)
Engine has too little power	Air filter is very dirty	– Remove the air filter. 🛠️ – Install the air filter. 🛠️
	Fuel filter is very dirty	– Check the fuel pressure. 🛠️
	Malfunction in the electronic fuel injection	– Read out the fault memory using the KTM diagnostics tool. 🛠️
Engine overheats	Too little coolant in cooling system	– Check the cooling system for leaks. 🛠️ – Check the coolant level in the compensating tank. (📖 p. 136)
	Radiator fins very dirty	– Clean radiator fins.
	Foam formation in cooling system	– Drain the coolant. 🛠️ – Fill/bleed the cooling system. 🛠️
	Buckled or damaged radiator hose	– Change the radiator hose. 🛠️
	Thermostat defective	– Check the thermostat. 🛠️
	Fuse 4 is blown	– Change the fuses of individual electrical power consumers. (📖 p. 132)
	Defect in radiator fan system	– Check the radiator fan system. 🛠️
Malfunction indicator lamp lights up or flashes	Malfunction in the electronic fuel injection	– Read out the fault memory using the KTM diagnostics tool. 🛠️
N The idling speed indicator lamp does not light up when the transmission is in neutral	Gear position sensor not programmed	– Read out the trouble code memory using the KTM diagnostics tool. 🛠️
The engine dies during the trip	Lack of fuel	– Refuel. (📖 p. 76)
	Fuse 1 , 2 or 3 blown	– Change the fuses of individual electrical power consumers. (📖 p. 132)
The ABS warning lamp lights up	ABS fuse blown	– Change the ABS fuses. (📖 p. 131)

Faults	Possible cause	Action
The ABS warning lamp lights up	Wheel speeds of front and rear wheels differ greatly	– Stop, switch off the ignition, start again.
	Malfunction in ABS	– Read out the ABS fault memory using the KTM diagnostics tool. 🛠️
High oil consumption	Engine vent hose bent	– Route the vent hose without bends or change it if necessary.
	Engine oil level too high	– Check the engine oil level. (📖 p. 141)
	Engine oil too thin (low viscosity)	– Change the engine oil and the oil filter, clean the oil screens. 🛠️ (📖 p. 141)
Headlight and position light are not functioning	Fuse 6 is blown	– Change the fuses of individual electrical power consumers. (📖 p. 132)
Turn signal, brake light, and horn are not functional	Fuse 5 is blown	– Change the fuses of individual electrical power consumers. (📖 p. 132)
Time is not displayed or not correctly displayed	Fuse 1 blown	– Change the fuses of individual electrical power consumers. (📖 p. 132)
12-V battery discharged	Ignition was not switched off when vehicle was parked	– Charge the 12-V battery. 🛠️ (📖 p. 128)
	The 12-V battery is not being charged by the alternator	– Check the charging voltage. 🛠️
The combination instrument shows nothing in the display	Fuse 1 or 2 blown	– Change the fuses of individual electrical power consumers. (📖 p. 132) – Set time and date.

23.1 Engine

Design	2-cylinder 4-stroke in-line engine, water-cooled
Displacement	890 cm ³ (54.31 cu in)
Stroke	68.8 mm (2.709 in)
Bore	90.7 mm (3.571 in)
Compression ratio	13.5:1
Control	DOHC, 4 valves per cylinder controlled via cam lever, chain drive
Valve diameter, intake	37 mm (1.46 in)
Valve diameter, exhaust	30 mm (1.18 in)
Valve play, cold	
Intake at: 20 °C (68 °F)	0.10 ... 0.15 mm (0.0039 ... 0.0059 in)
Exhaust at: 20 °C (68 °F)	0.15 ... 0.20 mm (0.0059 ... 0.0079 in)
Crankshaft bearing	Slide bearing
Conrod bearing	Slide bearing
Piston pin bearing	Piston pin with bronze coating
Pistons	Forged light alloy
Piston rings	1 compression ring, 1 lower compression ring, 1 oil ring with spring expander
Engine lubrication	Semi-dry sump lubrication system with two trochoid pumps
Primary transmission	39:75
Clutch	Slipper clutch in oil bath/mechanically operated
Transmission	6-gear transmission, claw shifted
Transmission ratio	
First gear	13:37
Second gear	17:34
Third gear	20:31
Fourth gear	22:28
Fifth gear	24:26
Sixth gear	23:22
Mixture preparation	Electronic fuel injection
Ignition	Contactless controlled fully electronic ignition with digital ignition adjustment
Alternator	12 V, 400 W
Spark plug	NGK LMAR9AI-10
Spark plug electrode gap	1.0 mm (0.039 in)
Cooling	Water cooling, permanent circulation of coolant by water pump
Idle speed	1,400 ± 50 rpm
Starting aid	Starter motor

23.2 Engine tightening torques

Screw plug, water pump drain hole	EJOTALtracs®Plus 60x14	8 Nm (5.9 lbf ft) Loctite®243™
Screw, bleeder flange	EJOTALtracs® M6x12	8 Nm (5.9 lbf ft) Loctite®243™
Hose clamp, intake flange	M4	2.5 Nm (1.84 lbf ft)
Nozzle, engine vent	M5	2 Nm (1.5 lbf ft)
Oil nozzle for piston cooling	M5	2 Nm (1.5 lbf ft)
Oil nozzle in cylinder head	M5	2 Nm (1.5 lbf ft)
Remaining screws, engine	M5	6 Nm (4.4 lbf ft)
Screw, cam lever axial lock	M5	6 Nm (4.4 lbf ft) Loctite®243™
Screw, crankshaft speed sensor	M5	6 Nm (4.4 lbf ft) Loctite®243™
Screw, gear position sensor	M5	6 Nm (4.4 lbf ft) Loctite®243™
Screw, oil filter cover	M5	6 Nm (4.4 lbf ft)
Screw, pressure plate	M5	3 Nm (2.2 lbf ft) Loctite®243™
Screw, shift drum retaining bracket	M5	6 Nm (4.4 lbf ft) Loctite®243™
Screw, shift shaft sensor	M5	6 Nm (4.4 lbf ft) Loctite®243™
Screw, thermostat case	M5	6 Nm (4.4 lbf ft) Loctite®243™
Securing screw, balancer shaft	M5	5 Nm (3.7 lbf ft) Loctite®243™
Swing angle sensor screw	M5	6 Nm (4.4 lbf ft) Loctite®243™
Nut, starter motor cable	M6	5 Nm (3.7 lbf ft)
Remaining screws, engine	M6	10 Nm (7.4 lbf ft)
Screw, alternator cover	M6x30	10 Nm (7.4 lbf ft)
Screw, alternator cover	M6x35	10 Nm (7.4 lbf ft)
Screw, camshaft bearing bridge	M6	10 Nm (7.4 lbf ft)
Screw, clutch cable retaining bracket	M6	10 Nm (7.4 lbf ft) Loctite®243™
Screw, clutch cover	M6	10 Nm (7.4 lbf ft)
Screw, clutch release lever	M6	10 Nm (7.4 lbf ft) Loctite®243™
Screw, clutch spring	M6	10 Nm (7.4 lbf ft)
Screw, cylinder head	M6	10 Nm (7.4 lbf ft)
Screw, engine case	M6x30	12 Nm (8.9 lbf ft)
Screw, engine case	M6x60	12 Nm (8.9 lbf ft)
Screw, freewheel ring	M6	14 Nm (10.3 lbf ft) Loctite®243™
Screw, ignition coil	M6	8 Nm (5.9 lbf ft)
Screw, locking lever	M6	10 Nm (7.4 lbf ft) Loctite®243™

Screw, main shaft bearing support	M6	10 Nm (7.4 lbf ft) Loctite®243™
Screw, oil pan	M6x30	10 Nm (7.4 lbf ft)
Screw, oil pan	M6x35	10 Nm (7.4 lbf ft)
Screw, oil pump cover	M6	10 Nm (7.4 lbf ft) Loctite®243™
Screw, oil pump unit	M6	10 Nm (7.4 lbf ft)
Screw, oil/water heat exchanger	M6	10 Nm (7.4 lbf ft) Loctite®243™
Screw, shift drum locating	M6	10 Nm (7.4 lbf ft) Loctite®243™
Screw, shift lever	M6	14 Nm (10.3 lbf ft) Loctite®243™
Screw, shift shaft retaining bracket	M6	10 Nm (7.4 lbf ft) Loctite®243™
Screw, starter motor	M6	10 Nm (7.4 lbf ft)
Screw, stator	M6	10 Nm (7.4 lbf ft) Loctite®243™
Screw, timing chain shaft	M6	10 Nm (7.4 lbf ft)
Screw, upper guide rail	M6	8 Nm (5.9 lbf ft) Loctite®243™
Screw, valve cover	M6	10 Nm (7.4 lbf ft)
Screw, water pump cover	M6	10 Nm (7.4 lbf ft) Loctite®243™
Screw, water pump wheel	M6	10 Nm (7.4 lbf ft) Loctite®243™
Nut, exhaust flange	M8	15 Nm (11.1 lbf ft) Copper paste
Oil nozzle for clutch lubrication	M8	5 Nm (3.7 lbf ft) Loctite®243™
Remaining screws for engine	M8	20 Nm (14.8 lbf ft)
Screw plug, locking screw	M8	15 Nm (11.1 lbf ft)
Screw, engine case	M8x45	25 Nm (18.4 lbf ft) Screw support greased
Screw, engine case	M8x55	25 Nm (18.4 lbf ft) Screw support greased
Screw, engine case	M8x65	25 Nm (18.4 lbf ft) Screw support greased
Screw, engine case	M8x90	25 Nm (18.4 lbf ft) Screw support greased
Screw, knock sensor	M8	20 Nm (14.8 lbf ft)
Screw, oil pump idler gear	M8	15 Nm (11.1 lbf ft) Loctite®243™
Screw, tensioning rail	M8	15 Nm (11.1 lbf ft) Loctite®243™
Stud, exhaust flange	M8	15 Nm (11.1 lbf ft) Loctite®243™

Screw, conrod bearing	M8x0.75	1st stage 5 Nm (3.7 lbf ft) 2nd stage 20 Nm (14.8 lbf ft) 3rd stage 90° Screw support and thread oiled
Spark plug	M10	11 Nm (8.1 lbf ft)
Oil pressure sensor	M10x1	10 Nm (7.4 lbf ft)
Screw plug, bearing support	M10x1	12 Nm (8.9 lbf ft) Loctite®243™
Screw plug, cam lever axis	M10x1	8 Nm (5.9 lbf ft)
Screw, unlocking of timing chain tensioner	M10x1	8 Nm (5.9 lbf ft)
Coolant temperature sensor	M10x1.25	10 Nm (7.4 lbf ft)
Screw, cylinder head	M10x1.25	Tightening sequence: Observe tightening sequence. 1st stage 5 Nm (3.7 lbf ft) 2nd stage 15 Nm (11.1 lbf ft) 3rd stage 90° 4th stage 90° Screw support greased/thread oiled
Screw plug, cylinder head oil drain	M12x1.5	15 Nm (11.1 lbf ft)
Screw, rotor	M12x1.5	90 Nm (66.4 lbf ft) Thread greased
Screw plug, water jacket	M16x1.5	20 Nm (14.8 lbf ft) Loctite®243™
Nut, engine sprocket	M20x1.5	100 Nm (73.8 lbf ft) Loctite®243™
Nut, inner clutch hub	M20x1.5	135 Nm (99.6 lbf ft)
Plug, oil screen	M20x1.5	20 Nm (14.8 lbf ft)
Plug, timing chain tensioner	M24x1.5	25 Nm (18.4 lbf ft)
Screw plug, alternator cover	M24x1.5	8 Nm (5.9 lbf ft)

23.3 Capacities

23.3.1 Engine oil

Engine oil	2.8 l (3 qt.)	Engine oil (SAE 10W/50) ( p. 163)
------------	---------------	--

23.3.2 Coolant

Coolant	1.60 l (1.69 qt.)	Coolant ( p. 163)
---------	-------------------	---

23.3.3 Fuel

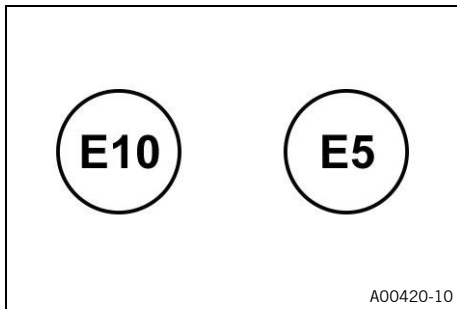

Please observe the labels on EU fuel pumps.

Total fuel tank capacity, approx.	20 l (5.3 US gal)	Super unleaded (ROZ 95) ( p. 164)
Fuel reserve, approx.	3 l (3 qt.)	

23.4 Chassis

Frame	Lattice frame made of chrome molybdenum steel tubing, powder-coated
Fork	WPXPLOR 5548
Shock absorber	WPXPLOR 5746
Suspension travel	
front	240 mm (9.45 in)
rear	240 mm (9.45 in)
Brake system	
front	Double disc brake with radially mounted four-piston brake calipers, floating brake discs
rear	Single disc brake with dual-piston brake caliper, floating brake disc
Brake discs - diameter	
front	320 mm (12.6 in)
rear	260 mm (10.24 in)
Brake discs - wear limit	
front	4.5 mm (0.177 in)
rear	4.5 mm (0.177 in)
Tire pressure solo / with passenger	
front	2.4 bar (35 psi)
rear	2.4 bar (35 psi)
Offroad tire pressure	
front	1.8 bar (26 psi)
rear	1.8 bar (26 psi)
Tire pressure full payload	
front	2.6 bar (38 psi)
rear	2.9 bar (42 psi)
Secondary drive ratio	16:45
Chain	5/8 x 1/4" (520) X-ring
Steering head angle	63.7°

Wheelbase	1,528 mm (60.16 in)
Seat height, unloaded	880 mm (34.65 in)
Ground clearance, unloaded	263 mm (10.35 in)
Weight without fuel, approx.	200 kg (441 lb.)
Maximum permissible front axle load	175 kg (386 lb.)
Maximum permissible rear axle load	275 kg (606 lb.)
Maximum permissible total weight	450 kg (992 lb.)

23.5 Electrical system

12-V battery	HTZ12A-BS	Battery voltage: 12 V Nominal capacity: 10 Ah Maintenance-free
Fuse	75011088010	10 A
Fuse	75011088015	15 A
Fuse	75011088025	25 A
Fuse	58011109130	30 A

Low beam/high beam	LED
Daytime running light/position light	LED
Combination instrument lighting and indicator lamps	LED
Turn signal	LED
Brake/tail light	LED
License plate lamp	LED

23.6 Tires

Front tire	Rear tire
90/90 - 21 M/C 54R M+S TL Metzeler Karoo 3	150/70 - 18 M/C 70R M+S TL Metzeler Karoo 3
The tires specified represent one of the possible series production tires. Additional information is available in the Service section under: KTM.COM	

23.7 Fork

Fork article number	14.18.8S.54
Fork	WPXPLOR 5548
Compression damping	
Comfort	20 clicks
Standard	15 clicks
Sport	10 clicks
Full payload	15 clicks
Rebound damping	
Comfort	18 clicks
Standard	15 clicks
Sport	10 clicks
Full payload	15 clicks
Spring preload - Preload Adjuster	

Comfort	+0	
Standard	+0	
Sport	+0	
Full payload	+3	
Spring length with preload spacer(s)	464 mm (18.27 in)	
Spring rate		
Weight of rider: 75 ... 85 kg (165 ... 187 lb.)	6.7 N/mm (38.3 lb/in)	
Fork length	912 mm (35.91 in)	
Fork oil per fork leg	630 ± 5 ml (21.3 ± 0.17 fl. oz.)	Fork oil (SAE 4) (48601166S1) (📖 p. 164)

23.8 Shock absorber

Shock absorber article number	0637C454U305000	
Shock absorber	WPXPLOR 5746	
Low-speed compression damping		
Comfort	20 clicks	
Standard	15 clicks	
Sport	10 clicks	
Full payload	7 clicks	
High-speed compression damping		
Comfort	2 turns	
Standard	1.5 turns	
Sport	1 turn	
Full payload	0.5 turns	
Rebound damping		
Comfort	23 clicks	
Standard	15 clicks	
Sport	12 clicks	
Full payload	5 clicks	
Spring preload - Preload Adjuster		
Comfort	4 turns	
Standard	4 turns	
Sport	4 turns	
Full payload	10 turns	
Fitted length	380 mm (14.96 in)	
Spring length	210 mm (8.27 in)	
Spring rate		
Weight of rider: 75 ... 85 kg (165 ... 187 lb.)	95 N/mm (542 lb/in)	
Gas pressure	16 bar (232 psi)	
Damper oil	Shock absorber fluid (SAE 2.5) (50180751S1) (📖 p. 164)	

23.9 Chassis tightening torques

Brake fluid reservoir cover, front	-	1 Nm (0.7 lbf ft)
Brake fluid reservoir cover, rear	-	1.5 Nm (1.11 lbf ft)
Compensating tank cover	-	1.1 Nm (0.81 lbf ft)
Nut, valve	ISO 10V2	12 Nm (8.9 lbf ft) Loctite®2701™
Remaining screws, chassis	EJOTPT® K45x12	1 Nm (0.7 lbf ft)
Remaining screws, chassis	EJOTPT® K50x12	1 Nm (0.7 lbf ft)
Remaining screws, chassis	EJOTPT® K50x14	1 Nm (0.7 lbf ft)
Remaining screws, chassis	EJOTPT® K50x16	2 Nm (1.5 lbf ft)
Remaining screws, chassis	EJOTPT® K50x18	2 Nm (1.5 lbf ft)
Screw, tail light	EJOT DELTA PT® 45x12-Z	1.5 Nm (1.11 lbf ft)
Socket for electrical accessories	-	4 Nm (3 lbf ft)
Throttle valve body hose clamp	-	2.8 Nm (2.07 lbf ft)
Remaining nuts, chassis	M4	3 Nm (2.2 lbf ft)
Remaining screws, chassis	M4	3 Nm (2.2 lbf ft)
Screw, fixed grip, left	M4	3 Nm (2.2 lbf ft)
Remaining nuts, chassis	M5	5 Nm (3.7 lbf ft)
Remaining screws, chassis	M5	5 Nm (3.7 lbf ft)
Screw for throttle grip	M5	3.5 Nm (2.58 lbf ft)
Screw, air filter box	M5	3 Nm (2.2 lbf ft)
Screw, brake fluid reservoir for rear brake	M5	5 Nm (3.7 lbf ft) Loctite®243™
Screw, brake line holder on link fork	M5	1 Nm (0.7 lbf ft)
Screw, combination instrument	M5	4 Nm (3 lbf ft)
Screw, combination switch, left	M5	2 Nm (1.5 lbf ft)
Screw, combination switch, right	M5	5 Nm (3.7 lbf ft)
Screw, engine sprocket cover	M5	5 Nm (3.7 lbf ft) Loctite®243™
Screw, foot brake lever stub	M5	10 Nm (7.4 lbf ft) Loctite®243™
Screw, fork protector	M5x12	5 Nm (3.7 lbf ft)
Screw, fork protector	M5x17	5 Nm (3.7 lbf ft)
Screw, fuel level sensor	M5	3 Nm (2.2 lbf ft)
Screw, fuel tank clamp	M5	3 Nm (2.2 lbf ft)
Screw, fuel tank insert	M5	3 Nm (2.2 lbf ft)
Screw, headlight mask	M5	3.5 Nm (2.58 lbf ft)
Screw, headlight mask intermediate part	M5	3.5 Nm (2.58 lbf ft)
Screw, heat guard	M5	5 Nm (3.7 lbf ft) Loctite®243™
Screw, instrument support on mask support, front	M5	3.5 Nm (2.58 lbf ft)
Screw, instrument support on mask support, rear	M5	5 Nm (3.7 lbf ft)

Screw, license plate holder	M5	5 Nm (3.7 lbf ft) Loctite®243™
Screw, lower rear panel	M5	3 Nm (2.2 lbf ft)
Screw, mask support	M5	3.5 Nm (2.58 lbf ft)
Screw, mask support cover	M5	3.5 Nm (2.58 lbf ft)
Screw, side stand sensor	M5	2 Nm (1.5 lbf ft) Loctite®243™
Screw, splash protector	M5	2.8 Nm (2.07 lbf ft)
Screw, trim	M5	3 Nm (2.2 lbf ft)
Spoke nipple	M5	6 Nm (4.4 lbf ft)
Hand guard fitting	M6	6 Nm (4.4 lbf ft)
Nut, foot brake lever adjustment	M6	6 Nm (4.4 lbf ft)
Nut, hand brake lever	M6	Attach torque to nut. 10 Nm (7.4 lbf ft)
Nut, push rod, foot brake lever	M6	6 Nm (4.4 lbf ft)
Nut, shift rod	M6	6 Nm (4.4 lbf ft)
Nut, shift rod	M6LH	6 Nm (4.4 lbf ft)
Remaining nuts, chassis	M6	10 Nm (7.4 lbf ft)
Remaining screws, chassis	M6	10 Nm (7.4 lbf ft)
Screw activated carbon filter on retaining bracket	M6	8 Nm (5.9 lbf ft)
Screw cap, fuel tank cover	M6	5 Nm (3.7 lbf ft)
Screw, 6-D sensor	M6	5 Nm (3.7 lbf ft)
Screw, ABS module	M6	8 Nm (5.9 lbf ft)
Screw, ball joint of push rod on foot brake cylinder	M6	10 Nm (7.4 lbf ft) Loctite®243™
Screw, battery support bracket	M6	5 Nm (3.7 lbf ft)
Screw, battery terminal	M6	4.5 Nm (3.32 lbf ft)
Screw, brace for mask support	M6	10 Nm (7.4 lbf ft) Loctite®243™
Screw, brake assembly	M6	5 Nm (3.7 lbf ft)
Screw, cable on starter motor	M6	5 Nm (3.7 lbf ft)
Screw, cable on starter relay	M6	4.5 Nm (3.32 lbf ft)
Screw, clutch assembly	M6	5 Nm (3.7 lbf ft)
Screw, cross member in rear	M6x13	10 Nm (7.4 lbf ft) Loctite®243™
Screw, cross member in rear	M6x12	6 Nm (4.4 lbf ft) Loctite®243™
Screw, engine guard	M6x8	8 Nm (5.9 lbf ft)
Screw, engine guard	M6x10	10 Nm (7.4 lbf ft) Loctite®243™
Screw, engine guard retaining bracket	M6	10 Nm (7.4 lbf ft) Loctite®243™
Screw, foot brake cylinder	M6	10 Nm (7.4 lbf ft) Loctite®243™
Screw, footrest bracket, rear	M6	9 Nm (6.6 lbf ft) Loctite®243™

Screw, front brake disc	M6	14 Nm (10.3 lbf ft) Loctite®243™
Screw, front wheel speed sensor	M6	6 Nm (4.4 lbf ft)
Screw, fuel pump	M6	6 Nm (4.4 lbf ft)
Screw, fuel tank cover	M6x12	8 Nm (5.9 lbf ft)
Screw, fuel tank cover	M6x22	8 Nm (5.9 lbf ft)
Screw, fuel tank spoiler attachment	M6	3 Nm (2.2 lbf ft)
Screw, fuel tap	M6	6 Nm (4.4 lbf ft)
Screw, ground wire on frame	M6	6 Nm (4.4 lbf ft)
Screw, ground wire to starter motor	M6	10 Nm (7.4 lbf ft)
Screw, ignition lock (tamper-proof screw)	M6	Tighten until the head tears off. Loctite®243™
Screw, magnetic holder on side stand	M6	2 Nm (1.5 lbf ft) Loctite®243™
Screw, mask support on steering head	M6	10 Nm (7.4 lbf ft) Loctite®243™
Screw, presilencer exhaust clamp	M6	8 Nm (5.9 lbf ft) Copper paste
Screw, radiator bracket, bottom	M6	5 Nm (3.7 lbf ft)
Screw, rear brake disc	M6	14 Nm (10.3 lbf ft) Loctite®243™
Screw, rear wheel speed sensor	M6	6 Nm (4.4 lbf ft)
Screw, seat fixing	M6	6 Nm (4.4 lbf ft)
Screw, seat lock	M6	10 Nm (7.4 lbf ft) Loctite®243™
Screw, shift rod	M6	10 Nm (7.4 lbf ft) Loctite®243™
Screw, shift shaft deflector on shift shaft	M6	10 Nm (7.4 lbf ft) Loctite®243™
Screw, voltage regulator	M6	6 Nm (4.4 lbf ft)
Foot brake lever, fitting	M8	25 Nm (18.4 lbf ft) Loctite®2701™
Hand guard screw	M8	25 Nm (18.4 lbf ft)
Nut, manifold on cylinder head	M8	Tighten the nuts evenly. Do not bend the metal. 20 Nm (14.8 lbf ft) Copper paste
Nut, rear sprocket screw	M8	35 Nm (25.8 lbf ft) Loctite®2701™
Pin, rear brake caliper	M8	22 Nm (16.2 lbf ft) Loctite®243™
Remaining nuts, chassis	M8	25 Nm (18.4 lbf ft)
Remaining screws, chassis	M8	25 Nm (18.4 lbf ft)
Screw, bottom triple clamp	M8	12 Nm (8.9 lbf ft)
Screw, engine fixing arm linkage bracket	M8	25 Nm (18.4 lbf ft) Loctite®243™

Screw, engine guard frame	M8	25 Nm (18.4 lbf ft) Loctite®243™
Screw, foot brake lever return spring pin	M8	12 Nm (8.9 lbf ft) Loctite®2701™
Screw, fork stub	M8	15 Nm (11.1 lbf ft)
Screw, front brake caliper	M8	25 Nm (18.4 lbf ft)
Screw, grab handle	M8	25 Nm (18.4 lbf ft) Loctite®243™
Screw, handlebar clamp	M8	20 Nm (14.8 lbf ft)
Screw, main silencer fastening	M8	15 Nm (11.1 lbf ft)
Screw, main silencer holder	M8	25 Nm (18.4 lbf ft)
Screw, presilencer on frame	M8	25 Nm (18.4 lbf ft) Loctite®243™
Screw, rear footrest bracket	M8	25 Nm (18.4 lbf ft) Loctite®243™
Screw, seat bracket	M8	25 Nm (18.4 lbf ft) Loctite®243™
Screw, shift lever	M8	25 Nm (18.4 lbf ft) Loctite®2701™
Screw, spring holder plate on side stand bracket	M8	15 Nm (11.1 lbf ft) Loctite®2701™
Screw, steering damper on holder	M8	8 Nm (5.9 lbf ft) Loctite®243™
Screw, steering damper on triple clamp	M8	8 Nm (5.9 lbf ft) Loctite®243™
Screw, steering stem	M8	20 Nm (14.8 lbf ft) Loctite®243™
Screw, subframe	M8	25 Nm (18.4 lbf ft) Loctite®243™
Screw, top triple clamp	M8	15 Nm (11.1 lbf ft)
Securing bolt for brake linings	M8	10 Nm (7.4 lbf ft)
Remaining nuts, chassis	M10	45 Nm (33.2 lbf ft)
Remaining screws, chassis	M10	45 Nm (33.2 lbf ft)
Screw, engine bracket	M10	45 Nm (33.2 lbf ft) Loctite®243™
Screw, front footrest bracket	M10x30	45 Nm (33.2 lbf ft) Loctite®243™
Screw, front footrest bracket	M10x40	45 Nm (33.2 lbf ft) Loctite®243™
Screw, front footrest bracket	M10x65	45 Nm (33.2 lbf ft) Loctite®243™
Screw, handlebar support	M10	45 Nm (33.2 lbf ft) Loctite®243™
Screw, side stand	M10	40 Nm (29.5 lbf ft) Loctite®243™
Screw, subframe	M10	50 Nm (36.9 lbf ft) Loctite®243™
Banjo bolt, brake line	M10x1	25 Nm (18.4 lbf ft)
Nut, turn signal	M10x1.25	4 Nm (3 lbf ft)

Screw, front brake caliper	M10x1.25	45 Nm (33.2 lbf ft) Loctite®243™
Screw, bottom shock absorber	M12	80 Nm (59 lbf ft) Loctite®2701™
Screw, swingarm pivot	M12	100 Nm (73.8 lbf ft)
Screw, top shock absorber	M12	80 Nm (59 lbf ft) Loctite®2701™
Lambda sensor	M18x1.5	50 Nm (36.9 lbf ft)
Adjusting screw, swingarm	M20LHx1.5	10 Nm (7.4 lbf ft)
Nut, rear wheel spindle	M25x1.5	90 Nm (66.4 lbf ft) Thread and contact area of wheel spindle greased
Screw, front wheel spindle	M25x1.5	45 Nm (33.2 lbf ft) Thread greased
Screw, steering head	M25x1.5	18 Nm (13.3 lbf ft)

24.1 Declarations of conformity

i Info

The functional and equipment scope is model-dependent and may not include all wireless systems and application areas referred to.





JNS Instruments Ltd. hereby declares that the **252M1100** wireless system conforms with the relevant guidelines. The full text of the Declaration of Conformity is available at the following Internet address.
Certification website: <http://www.ktm.com/252m1100>

KTM AG hereby declares that the **Immo641** wireless system conforms with the relevant guidelines. The full text of the Declaration of Conformity is available at the following Internet address.
Certification website: <http://www.ktm.com/immo641>

Schrader Electronics Ltd hereby declares that the **Tyre Pressure Monitoring System** wireless system conforms with the relevant guidelines. The full text of the Declaration of Conformity is available at the following Internet address.
Certification website: <http://www.ktm.com/tpms>

24.2 Country-specific declarations of conformity

Immo641

TRA REGISTERED No:
ER63251/18
DEALER No:
DA74519/18

Complies with
IMDA Standards
DA103787

ictQATAR
Type Approval reg. No.:
CRA/SA/2018/R-7050

RTIKTM18-0315, KTM, Minda Immo641
La operación de este equipo está sujeta a las siguientes dos condiciones: (1) es posible que este equipo o dispositivo no cause interferencia perjudicial y (2) este equipo o dispositivo debe aceptar cualquier interferencia, incluyendo la que pueda causar su operación no deseada.

57743/SDPPI/2018
PLG ID: 7757



R-R-KTM-MindaImmo641

Company Name: KTM AG
Equipment Name: Immobilizer System
Model Name: Minda Immo641
Manufacturer Date:
Manufacturer / Country: Minda Corporation Limited / India



UA.TR.109

Israel 51-65016

מוציא דה פטור מרישיון הפעלה אלווטי.
המוציא אסור לשימוש למתן שרות לבד ג'.
אסור להחליף אנטנת המכשיר המקוריית.
אסור לעשות במכשיר כל שינוי טכני.

This product contains radio equipment (125 kHz transmitter) which is conform with the regulations for communications equipment (extremely low-power radio station) specified in article 6, paragraph 1 of the Radio Law Enforcement Regulations.



03469-18-11400

This product does not need an Israeli wireless operation license.
It is forbidden to use this product for service to third party.
It is forbidden to replace the original antenna.
It is forbidden to make any technical change in this product.

AGREE PAR L'ANRT MAROC
Numéro d'agrément: MR 16565 ANRT 2018
Date d'agrément: 15/05/2018

"Este equipamento opera em caráter secundário, isto é, não tem direito a proteção contra interferência prejudicial, mesmo de estações do mesmo tipo, e não pode causar interferência a sistemas operando em caráter primário."

V01514-01

Brake fluid DOT 4 / DOT 5.1**Standard/classification**

- DOT

Guideline

- Use only brake fluid that complies with the specified standard (see specifications on the container) and that exhibits the corresponding properties.

Recommended supplier**Castrol**

- **REACT PERFORMANCE DOT 4**

MOTOREX®

- **Brake Fluid DOT 5.1**

Coolant**Guideline**

- Only use high-grade, silicate-free coolant with corrosion inhibitor additive for aluminum motors. Low grade and unsuitable antifreeze causes corrosion, deposits and frothing.
- Do not use pure water as only coolant is able to meet the requirements needed in terms of corrosion protection and lubrication properties.
- Only use coolant that complies with the requirements stated (see specifications on the container) and that has the relevant properties.

Antifreeze protection to at least	-25 °C (-13 °F)
-----------------------------------	-----------------

The mixture ratio must be adjusted to the necessary antifreeze protection. Use distilled water if the coolant needs to be diluted.

The use of premixed coolant is recommended.

Observe the coolant manufacturer specifications for antifreeze protection, dilution and miscibility (compatibility) with other coolants.

Recommended supplier**MOTOREX®**

- **COOLANT M3.0**

Engine oil (SAE 10W/50)**Standard/classification**

- JASO T903 MA2 (📖 p. 166)
- SAE (📖 p. 166) (SAE 10W/50)

Guideline

- Use only engine oils that comply with the specified standards (see specifications on the container) and that possess the corresponding properties.

Fully synthetic engine oil

Recommended supplier**MOTOREX®**

- **Power Synt 4T**

Fork oil (SAE 4) (48601166S1)

Standard/classification

- SAE (📖 p. 166) (SAE 4)

Guideline

- Use only oils that comply with the specified standards (see specifications on the container) and that exhibit the corresponding properties.

Shock absorber fluid (SAE 2.5) (50180751S1)

Standard/classification

- SAE (📖 p. 166) (SAE 2.5)

Guideline

- Use only oils that comply with the specified standards (see specifications on the container) and that exhibit the corresponding properties.

Super unleaded (ROZ 95)

Standard/classification

- DIN EN 228 (ROZ 95)

Guideline

- Only use super unleaded fuel that matches or is equivalent to the specified standard.
- Fuel with an ethanol content of up to 10% (E10 fuel) is safe to use.



Info

Do **not** use fuel containing methanol (e.g., M15, M85, M100) or more than 10% ethanol (e.g., E15, E25, E85, E100).

Chain cleaner

Recommended supplier
MOTOREX®
– Chain Clean

Fuel additive

Recommended supplier
MOTOREX®
– Fuel Stabilizer

Long-life grease

Recommended supplier
MOTOREX®
– Bike Grease 2000

Motorcycle cleaner

Recommended supplier
MOTOREX®
– Moto Clean

Perfect finish and high gloss polish for paints

Recommended supplier
MOTOREX®
– Moto Shine

Preserving materials for paints, metal and rubber

Recommended supplier
MOTOREX®
– Moto Protect

Special cleaner for glossy and matte paint finishes, metal and plastic surfaces

Recommended supplier
MOTOREX®
– Quick Cleaner

Street chain spray

Guideline
Recommended supplier
MOTOREX®
– Chainlube Road Strong

Universal oil spray

Recommended supplier
MOTOREX®
– Joker 440 Synthetic

JASO T903 MA2

Different technical development directions required a separate specification for motorcycles – the **JASO T903 MA2** standard.

Earlier, engine oils from the automobile industry were used for motorcycles because there was no separate motorcycle specification.

Whereas long service intervals are demanded for automobile engines, the focus for motorcycle engines is on high performance at high engine speeds.

In most motorcycle engines, the transmission and clutch are lubricated with the same oil.

The **JASO T903 MA2** standard meets these special requirements.

SAE

The SAE viscosity classes were defined by the Society of Automotive Engineers and are used for classifying oils according to their viscosity. The viscosity describes only one property of oil and says nothing about quality.

ABS	Anti-lock braking system	Safety system that prevents locking of the wheels when driving straight ahead without the influence of lateral forces
DRL	Daytime Running Light	Light, which enhances the visibility of the vehicle during the day but is not focused, and in contrast to low beam does not illuminate the road surface
ETTC	Engine traction torque control	Auxiliary function of the engine control, which prevents rear wheel locking with excessive engine braking effect, by lightly opening the throttle valve
-	KTM MY RIDE	System for wireless communication with appropriate cellphones and headsets for telephony and audio
MTC	Motorcycle Traction Control	Auxiliary function of the motor control that reduces engine torque with spinning rear wheel
OBD	On-board diagnosis	Vehicle system, which monitors the specified parameters of the vehicle electronics
-	Quickshifter +	Engine electronics function for shifting up and down without clutch actuation
TPMS	Tire pressure monitoring system	A safety system that monitors the tire pressure with the assistance of sensors in the tires and displays it to the rider

29 LIST OF ABBREVIATIONS

Art. no.	Article number
ca.	circa
cf.	compare
e.g.	for example
etc.	et cetera
i.a.	inter alia
no.	number
poss.	possibly





30.1 Red symbols

Red symbols indicate an error condition that requires immediate intervention.

	The oil pressure warning lamp lights up red – The oil pressure is too low. Stop immediately, taking care not to endanger yourself or other road users in the process, and switch off the engine.
---	--





30.2 Yellow and orange symbols

Yellow and orange symbols indicate an error condition that requires prompt intervention. Active driving aids are also represented by yellow or orange symbols.

	Malfunction indicator lamp lights up yellow – The OBD has detected a malfunction in the vehicle electronics. Come safely to a halt, and contact an authorized KTM workshop.
	ABS warning lamp lights up yellow – Status or error messages relating to ABS.
	TC indicator lamp lights up/flashes yellow – MTC (p. 139) is not enabled or is currently intervening. The TC indicator lamp also lights up if a malfunction is detected. Contact an authorized KTM workshop. The TC indicator lamp flashes, if MTC or MSR (optional) actively engage.
	The cruise control system indicator lamp (optional) lights up yellow – The cruise control system function is switched on, but cruise control is not activated.
	The general warning lamp lights up yellow – A note/warning note on operating safety has been detected. This is also shown in the display.

30.3 Green and blue symbols

Green and blue symbols reflect information.

	The turn signal indicator lamp flashes green simultaneously with the turn signal – The turn signal is switched on.
	The idle indicator lamp lights up green – The transmission is in neutral.
	The cruise control system indicator lamp (optional) lights up green – The cruise control system function is switched on and cruise control is activated.
	The high beam indicator lamp lights up blue – The high beam is switched on.

1	
12-V battery	
charging	128
installing	127
removing	125
A	
ABS	108
ABS fuses	
changing	131
ACC1	
front	135
rear	135
ACC2	
front	135
rear	135
Anti-lock braking system	108
Applying the brakes	73
Auxiliary substances	11
B	
Battery cover	
installing	95
removing	94
Brake discs	
checking	109
Brake fluid	
of front brake, adding	110
of rear brake, adding	113
Brake fluid level	
of front brake, checking	110
rear brake, checking	112
Brake linings	
front brake, checking	111
rear brake, checking	114
Brake system	108-114
Brakes	73
Breakdown	
towing	75
C	
Capacity	
coolant	153
engine oil	142, 153
fuel	77, 154
Chain	
checking	90
checking for dirt	88
cleaning	88
Chain tension	
adjusting	89
checking	89
Clutch lever	16
basic position, adjusting	61
Combination instrument	28-59
ABS	49
ABS display	34
activation and test	28
ambient air temperature indicator	36
Audio	38
Bluetooth	52
coolant temperature indicator	35
cruise control indicator (optional)	35
day-night mode	28
display	31
Display Theme	52
Distance	56
DRL	55
Extra Functions	59
Favorites	51
Favorites display	37
fuel level display	36
Fuel Cons	56
General Info	43
Headset	41
heated grip (optional)	34
"heating" (optional function)	57
Heating Grip (function optional)	50, 57
Heating Seat Pillion (function optional)	58
Heating Seat Rider (function optional)	50, 58
ice warning	29
indicator lamps	30
KTM MY RIDE	38
Language	57
Leave Rally (optional)	47
menu	38
Motorcycle	48
MTC	48
MTC display	35
MTC+MSR (optional)	49
navigation	39
Navigation display	37
overview	28
Pairing	39
Phone	40
Quick Selector 1	51
Quick Selector 1 display	37
Quick Selector 2	52
Quick Selector 2 display	37
Quick Shift+ (optional)	50
Rally (optional)	46
rally display (optional)	32

Ride display	34	Engine sprocket	
Ride Mode	45, 139	checking	90
seat heating (optional)	34	Engine traction torque control	73
Service	58	Environment	9
Settings	51	F	
shift warning light	33	Figures	11
slip adjustment (optional)	140	Foot brake lever	26
Speed	33	basic position, adjusting	63
Speedometer	33	free travel, checking	112
telephony	42	Foot brake lever stub	
Temperature	56	adjusting	62
Throttle Response (optional)	47, 140	Fork	80
time	36	compression damping, adjusting	80
TPMS	44	rebound, adjusting	81
Trip 1	43	spring preload, adjusting	81
Trip 2	43	Fork legs	
Trips/Data	42	dust boots, cleaning	100
Units	56	Fork part number	15
Warning	45	Fork protector	
warnings	29	installing	100
Combination switch	16	removing	100
overview	16	Free travel of clutch lever	
Coolant level		adjusting	144
checking in the compensating tank	136	checking	144
correcting in the compensating tank	137	Front fender	
Cooling system	136	installing	99
Cornering MTC	139	removing	99
Cruise control system		Front wheel	
operation	17	installing	116
Customer service	11	removing	115
D		Fuel cocks	22
Declarations of conformity	162	Fuel tank cover, left	
country-specific	162	installing	103
Diagnostics connector	135	removing	102
Driving	70	Fuel tank filler cap	
E		closing	22
Emergency OFF switch	19	opening	21
Engine		Fuel tank spoiler, left	
running in	66	installing	96
Engine guard		removing	95
installing	105	Fuel, oils, etc.	11
removing	104	Fuse	
Engine number	15	of individual electrical power consumers,	
Engine oil		changing	132
adding	143	G	
changing	141	Grab handles	25
Engine oil level			
checking	141		

H		Passenger foot pegs	26
Hand brake lever	16	Preparing for use	
basic position, adjusting	62	advice on preparing for first use	65
Handlebar position	60	after storage	147
adjusting	60	checks and maintenance measures when	
Headlight		preparing for use	68
daytime running light	125	Protective clothing	9
range, adjusting	134	Q	
setting, checking	133	Quickshifter +	69
Horn button	19	R	
I		Rear hub damping rubber pieces	
Ice warning	29	checking	120
Ignition lock	20	Rear sprocket	
Implied warranty	11	checking	90
Indicator lamps	30	Rear wheel	
Intended use	7	installing	118
K		removing	117
Key number	14	Refueling	
L		fuel	76
Light switch	17	Riding	
Load the vehicle	66	starting off	69
Luggage	66	Right fuel tank cover	
Luggage rack plate	25	installing	104
M		removing	103
Main fuse		Right fuel tank spoiler	
changing	130	installing	98
Main silencer		removing	97
installing	106	Right side cover	
removing	106	installing	94
Manufacturer warranty	11	removing	93
Misuse	7	S	
Motorcycle		Safe operation	8
cleaning	145	Seat	
lifting with front lifting gear	86	mounting	87
rear from the lifting gear, removing	86	removing	87
rear lifting gear, raising with	86	Seat lock	25
taking off front lifting gear	87	Service	11
Motorcycle traction control	139	Service schedule	78-79
MSR	73	Shift lever	26
O		basic position, adjusting	64
Oil filter		basic position, checking	64
changing	141	Shifting	70
Oil screens		Shock absorber	80
cleaning	141	Compression damping	82
Owner's Manual	9	high-speed compression damping, adjusting	83
P		low-speed compression damping, adjusting	82
Parking	74	rebound damping, adjusting	84
		spring preload, adjusting	84

Shock absorber article number	15	Towing	75
Side cover, left		Transporting	75
installing	93	Troubleshooting	148-149
removing	92	Tubeless tire system	123
Side stand	27	Turn signal switch	19
Socket for electrical accessories	21	Type label	14
Spare parts	11	U	
Spoke tension		Use definition	7
checking	122	V	
Start button	19	Vehicle identification number	14
Starting	68	View of vehicle	
Steering		front left	12
locking	20	rear right	13
unlocking	20	W	
Steering damper article number	15	Windshield	
Steering lock	20	adjusting	61
Stopping	74	installing	102
Storage	147	removing	101
Storage compartment on the left		Winter operation	
closing	23	checks and maintenance steps	146
opening	22	Work rules	9
Storage compartment on the right			
closing	24		
opening	24		
Switch			
on the left side of the handlebar	16		
on the right side of the handlebar	19		
T			
Technical accessories	11		
Technical data			
capacities	153		
chassis	154		
chassis tightening torques	157		
electrical system	155		
engine	150-161		
engine tightening torques	151		
fork	155		
shock absorber	156		
tires	155		
Throttle grip	16		
Time			
adjusting	54		
Tire condition			
checking	121		
Tire pressure			
checking	122		
Tire repair spray			
using	123		
Tool set	25		



3214536en

09/2021

