

890 SMT

ART. NO. 3240022EN



Perform the work described in these setup instructions before the vehicle is delivered to the customer.

Read the setup instructions in their entirety before beginning work.

These setup instructions were written to correspond to the latest state of this model series. We reserve the right to make modifications in the interest of technical advancement without at the same time updating these setup instructions.

We shall not provide a description of general workshop methods. Likewise, safety rules that apply in a workshop are not specified here. It is assumed that the work will be performed by a fully trained mechanic.

All specifications contained herein are non-binding. KTM Sportmotorcycle GmbH specifically reserves the right to modify or delete technical specifications, prices, colors, forms, materials, services, designs, equipment, etc., without prior notice and without specifying reasons, to adapt these to local conditions, as well as to stop production of a particular model without prior notice. KTM accepts no liability for delivery options, deviations from figures and descriptions, misprints, and other errors. The models portrayed partly contain special equipment that does not belong to the regular scope of supply.

© 2023 KTM Sportmotorcycle GmbH, Mattighofen Austria

All rights reserved

Reproduction, even in part, as well as copying of all kinds, is permitted only with the express written permission of the copyright owner.



ISO 9001(12 100 6061)

KTM applies quality assurance processes that lead to the highest possible product quality as defined in the ISO 9001 international quality management standard.

Issued by: TÜV Management Service

REG.NO. 12 100 6061

KTM Sportmotorcycle GmbH
Stallhofnerstraße 3
5230 Mattighofen, Austria

This document is valid for the following models:

890 SMT EU (F9703XG)

890 SMT US (F9775XG)



3240022en

21.12.2023

1 MEANS OF REPRESENTATION

1.1 Symbols used

The meaning of specific symbols is described below.



Indicates an expected reaction (e.g., of a work step or a function).



Indicates an unexpected reaction (e.g., of a work step or a function).



Indicates a page reference (more information is provided on the specified page).



Indicates information with more details or tips.



Indicates the result of a testing step.



Indicates a resistance measurement.



Indicates the end of an activity, including potential reworking.

1.2 Formats used

The typographical formats used in this document are explained below.

Proprietary name

Indicates a proprietary name.

Name®

Indicates a protected name.

Brand™

Indicates a brand available on the open market.

Underlined terms

Refer to technical details of the vehicle or indicate technical terms, which are explained in the glossary.

2.1 Transport mode

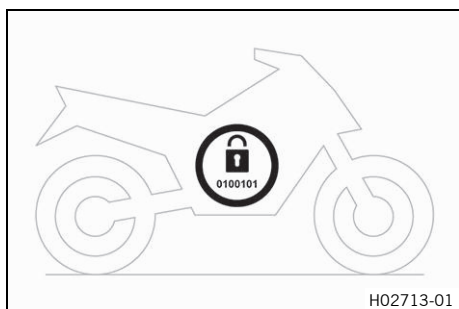

This vehicle was blocked for transport in the software. To operate the vehicle, the vehicle electronics must be enabled. This process is conducted during initial setup in KTM Dealer.net. Enabling ensures that the initial setup in KTM Dealer.net is documented.

Enabling can be performed either temporarily, e.g. for a test ride, or permanently for vehicle handover.

i Info

Make sure that the vehicle is permanently enabled before handing it over to the customer.

2.2 Diagnostics connector

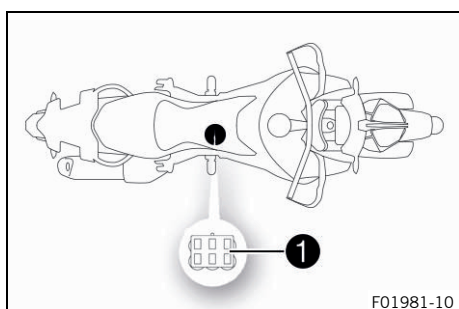

Diagnostics connector **1** is located under the battery cover.

2.3 Unpacking and setting up the vehicle

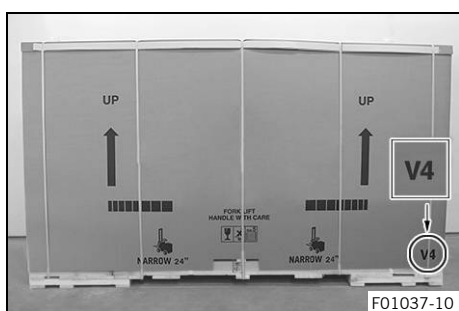

- Remove the straps and the box.
- Remove the adhesive tape in the upper area of the motorcycle.

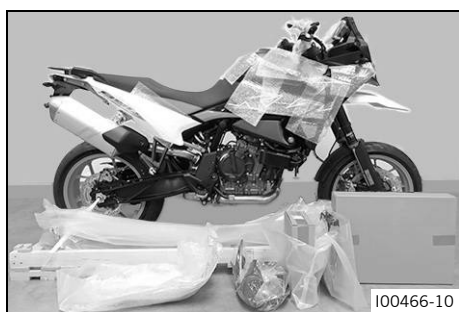

- Roll down the film at the sides.

Guideline

To avoid damaging the vehicle while setting it up, do not remove the protective film on each component until installing the component, and leave it on the vehicle until work has been completed.

- Remove the separate enclosure and unpack it. Check that the scope of supply is complete using the enclosed packing list.

i Info

The procedure for missing components is described in the Customer Service Manual.

- Check the vehicle for transport damage.

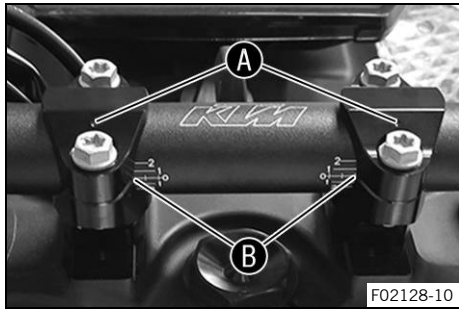

i Info

The procedure in the event of transport damage is described in the Customer Service Manual.

- Remove cable ties and protective film on the handlebar.



Warning

Danger of accidents A repaired handlebar poses a safety risk.

If the handlebar is bent or straightened, the material becomes fatigued. The handlebar may break as a result.

- Change the handlebar if the handlebar is damaged or bent.

- Position the handlebar.

i Info

Make sure the cables and wiring are positioned correctly.

- Position the handlebar clamps. Mount and tighten the screws evenly.

Guideline

Screw, handlebar clamp	M8	20 Nm (14.8 lbf ft)
------------------------	----	---------------------

- ✓ Markings **A** face the rear.
- ✓ Handlebar scale markings **B** are located centrally between the handlebar clamps.

i Info

Keep the installed gap dimensions equal when tightening.

- Check the handlebar position.
 - » If the handlebar position is not adjusted as required by the customer:
 - Adjust the handlebar position. (📖 p. 9)

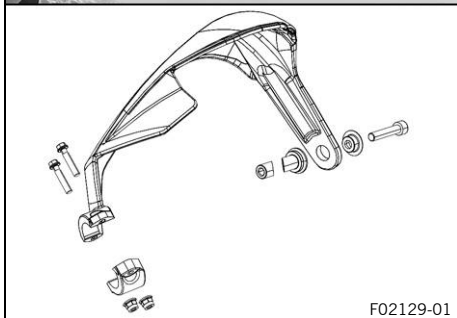

- Mount the right hand guard.

Guideline

Hand guard fitting	M6	6 Nm (4.4 lbf ft)
Hand guard screw	M8	25 Nm (18.4 lbf ft)

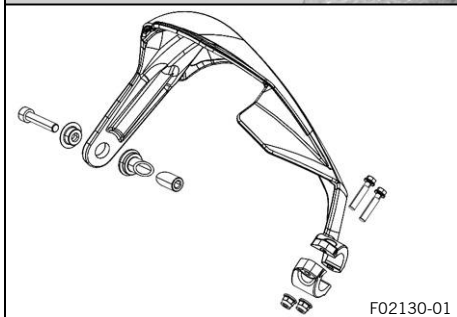
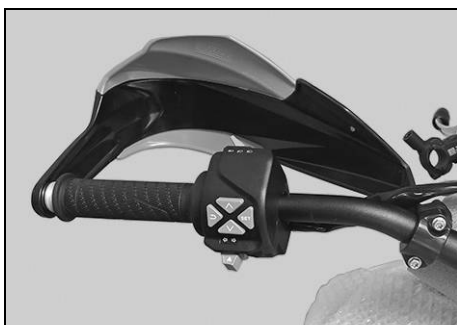

- Mount the left hand guard.

Guideline

Hand guard fitting	M6	6 Nm (4.4 lbf ft)
Hand guard screw	M8	25 Nm (18.4 lbf ft)



- Position the brake assembly on the handlebar.
- Position brake assembly clamp on the handlebar.
- ✓ The holding lug of the clamp engages in the combination switch.

- Mount and tighten screws ①.

Guideline

Screw, brake assembly	M6	5 Nm (3.7 lbf ft)
-----------------------	----	-------------------

- Tighten all the screws on the controls on the right half of the handlebar.

Guideline

Screw for throttle grip	M5	3.5 Nm (2.58 lbf ft)
Screw, combination switch, right	M5	5 Nm (3.7 lbf ft)



Info

Pay attention to the markings on the handlebar. Make sure the cables and wiring are positioned correctly.

- Tie the cables and wires together with the rubber straps supplied.
- Check the throttle grip for smooth operation.
- Position the clutch assembly on the handlebar.

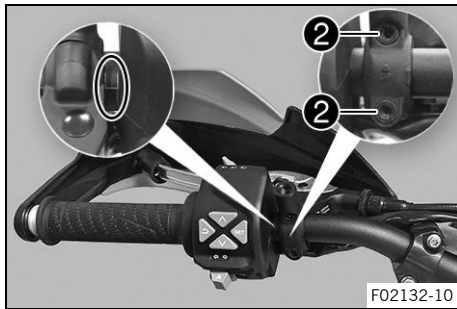

Info

Pay attention to the markings on the handlebar.

- Position the clutch assembly clamp on the handlebar.
- Mount and tighten screws ②.

Guideline

Screw, clutch assembly	M6	5 Nm (3.7 lbf ft)
------------------------	----	-------------------

- Tighten all the screws on the controls on the left half of the handlebar.

Guideline

Screw, fixed grip, left	M4	3 Nm (2.2 lbf ft)
Screw, combination switch, left	M5	2 Nm (1.5 lbf ft)



Info

Pay attention to the markings on the handlebar. Make sure the cables and wiring are positioned correctly.

- Tie the cables and wires together with the rubber straps supplied.
- Mount and tighten the rear mirror on both sides.

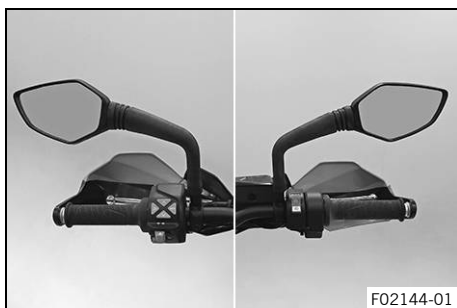

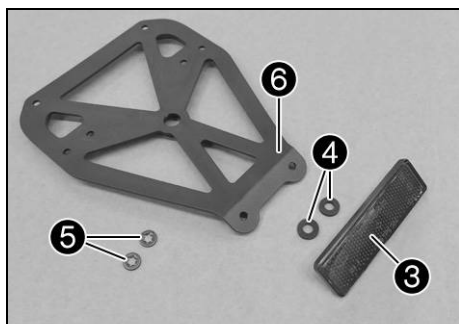

(890 SMT EU)

- Mount reflector **3** with rubber bushings **4** and tension washers **5** on the license plate holder **6**.
- Position the license plate bracket on the license plate support.
- Mount and tighten screws **7**.

Guideline

Screw, license plate holder	M5	5 Nm (3.7 lbf ft) Loctite®243™
-----------------------------	----	--

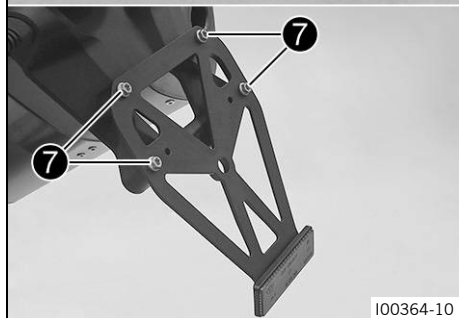

- Carefully loosen and remove the rear tension belt.

i Info

An assistant prevents the motorcycle from falling over.

- Carefully loosen and remove the tension belts around the lower triple clamp.
- ✓ The vehicle is released at the front.
- Together with an assistant, take the vehicle off the pallet.

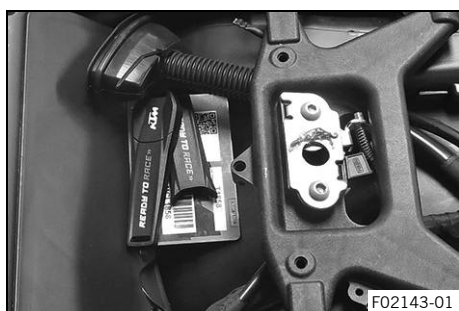

- Remove the seat. (📖 p. 9)
- Remove spare key and **KEYCODECARD** from under the seat and keep in a safe place for the handover.
- Charge the 12-V battery. (📖 p. 14)

Guideline

The 12-V battery must be fully charged before it is handed over to the customer.

i Info

The first charging process may take longer with a new 12-V battery.

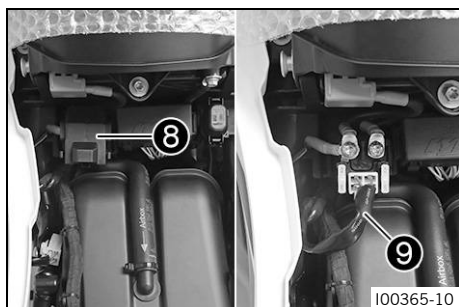

- Remove protection cap **8**.
- Plug in the plug **9** of the starter relay.
- Mount protection cap **8**.

i Info

The tool set can be stored in the left or right storage compartment.

The left storage compartment is described as an example.

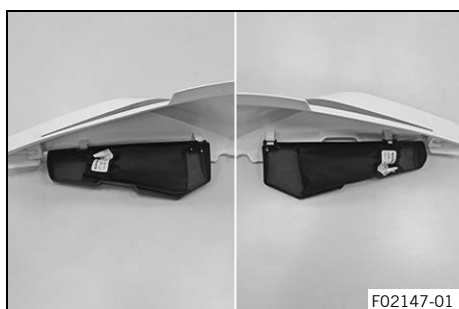

- Remove the left side cover. (📖 p. 10)
- Open storage compartment on the left. (📖 p. 10)
- Store the tool set in the storage compartment.
- Close storage compartment on the left. (📖 p. 11)
- Install the left side cover. (📖 p. 11)

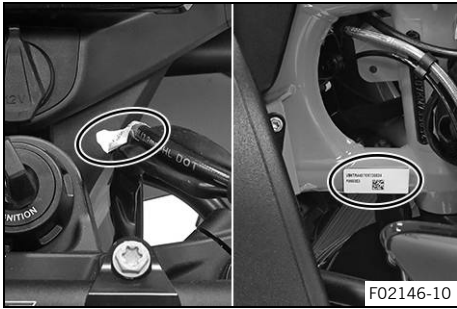

- Remove the labels from the brake line and the frame.
- Unpack and mount the **KTM PowerParts** included in the delivery (optional).



Info

Read the accompanying **KTM PowerParts** fitting instructions.

-
- Attach the stickers included in the scope of supply (optional).
 - Install windshield. (📖 p. 17)
 - Check the headlight setting. (📖 p. 18)
 - Install the left tank guard. (📖 p. 19)
 - Install the right tank guard. (📖 p. 19)
 - Turn the knurled screws on both fuel cocks counterclockwise as far as possible.
 - Refuel. (📖 p. 20)
 - Position all controls in their exact positions on the handlebar. Tighten all screws.
 - Remove the remaining film, padding, the corrugated cardboard, and the other packaging material.
 - Prepare the vehicle according to the specifications in **KTM Dealer.net** for handover to the customer.



Info

Transport mode must be deactivated to be able to start the motorcycle.

3.1 Adjusting the handlebar position



Warning

Danger of accidents A repaired handlebar poses a safety risk.

If the handlebar is bent or straightened, the material becomes fatigued. The handlebar may break as a result.

- Change the handlebar if the handlebar is damaged or bent.

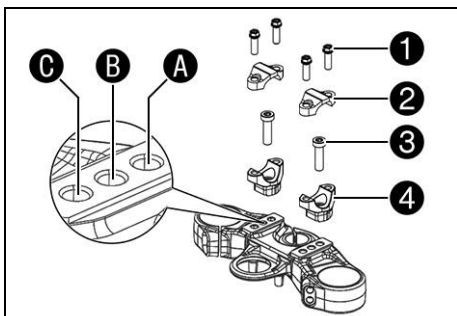

- Remove screws 1. Take off the handlebar clamps 2. Position the handlebar so that screws 3 are accessible.



Info

Cover the components to protect them against damage. Do not kink the cables and lines.

- Remove screws 3. Take off handlebar supports 4.
- Move the handlebar supports into the desired position B, A or C. Mount and tighten screws 3.

Guideline

Mount the left and right handlebar supports in the same position.

Screw, handlebar support	M10	45 Nm (33.2 lbf ft) Loctite®243™
--------------------------	-----	--

- Position the handlebar.



Info

Make sure the cables and wiring are positioned correctly.

- Position handlebar clamp. Mount screws 1 and tighten evenly.

Guideline

Screw, handlebar clamp	M8	20 Nm (14.8 lbf ft)
------------------------	----	---------------------

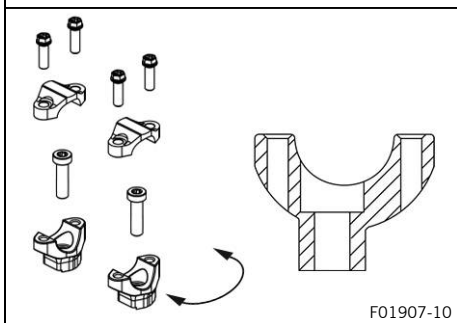

F01907-10

3.2 Removing the seat

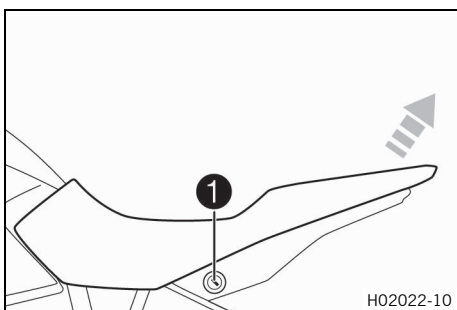

H02022-10

- Insert the ignition key in seat lock 1 and turn it clockwise.
- Raise the rear of the seat, pull the seat back, and lift it off.
- Remove the ignition key.

3.3 Mounting the seat

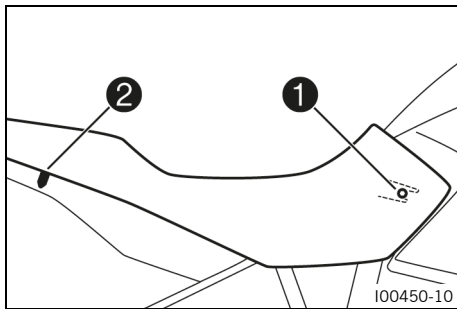

- Hook holding lug **1** of the seat onto the fuel tank, lower the rear and push it forward.
- Insert locking pin **2** into the lock housing and push down the rear of the seat until the locking pin engages with a click.
- Check that the seat is correctly mounted.

3.4 Removing the left side cover

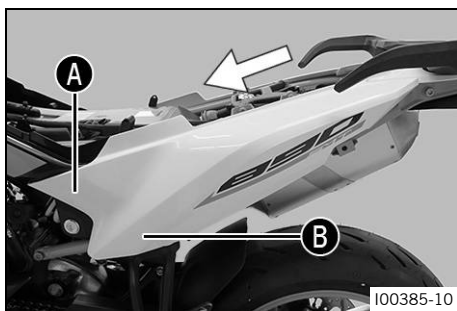

Preparatory work

- Remove the seat. (📖 p. 9)

Main work

- Remove left side cover from the rubber bushings in the areas **A** and **B**.
- Pull off the left side cover sideways and remove it toward the front.

3.5 Opening the storage compartment on the left

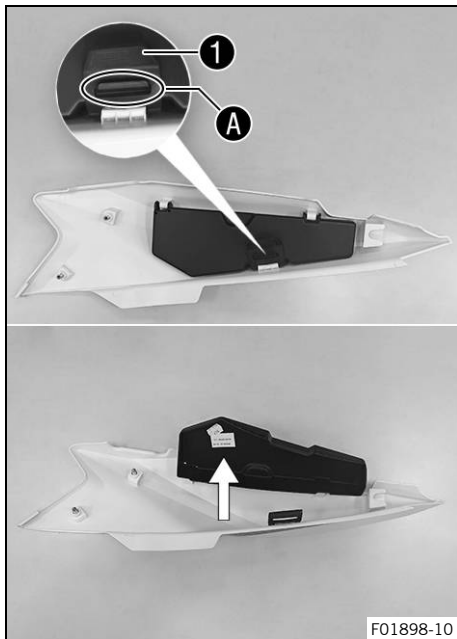

Preparatory work

- Remove the seat. (📖 p. 9)
- Remove the left side cover. (📖 p. 10)

Main work

- Lift the elastic fastener **1** and detach in area **A**.
- Open storage compartment.

3.6 Closing the storage compartment on the left

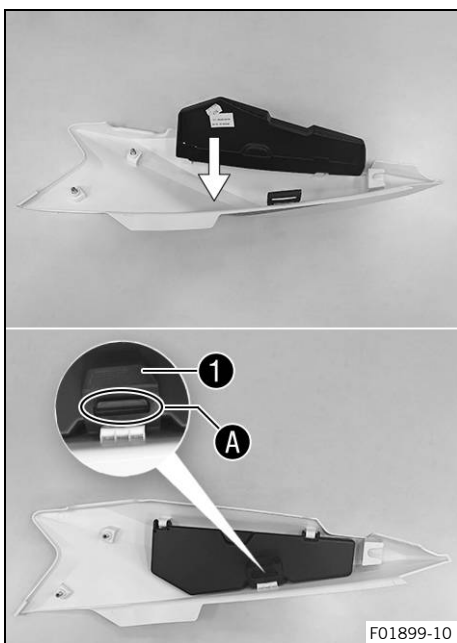

Main work

- Close the storage compartment.
- Raise elastic fastener ① and hang up in area A.

Finishing work

- Install the left side cover. (📖 p. 11)
- Mount the seat. (📖 p. 10)



3.7 Installing the left side cover

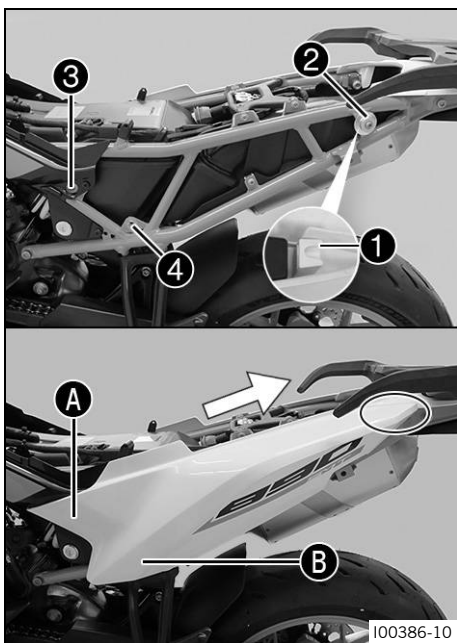

Main work

- Position the left side cover with holding lug ① on bushing ② and push backward.
- ✓ The left side cover engages under the tail part.
- Press the left side cover in area A into rubber bushing ③ and press into rubber bushing B in area ④.

Finishing work

- Mount the seat. (📖 p. 10)



3.8 Removing the right side cover

Preparatory work

- Remove the seat. (📖 p. 9)

Main work

- Remove the side cover from the rubber bushings in areas **A** and **B**.
- Pull off the right side cover sideways and remove it toward the front.

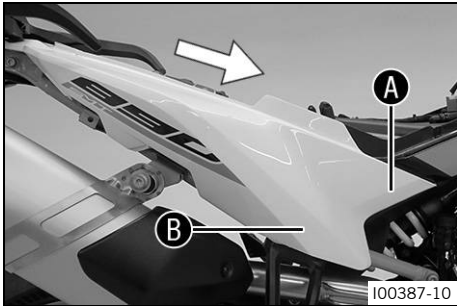

3.9 Opening the storage compartment on the right

Preparatory work

- Remove the seat. (📖 p. 9)
- Remove the right side cover. (📖 p. 12)

Main work

- Lift the elastic fastener **1** and detach in area **A**.
- Open storage compartment.

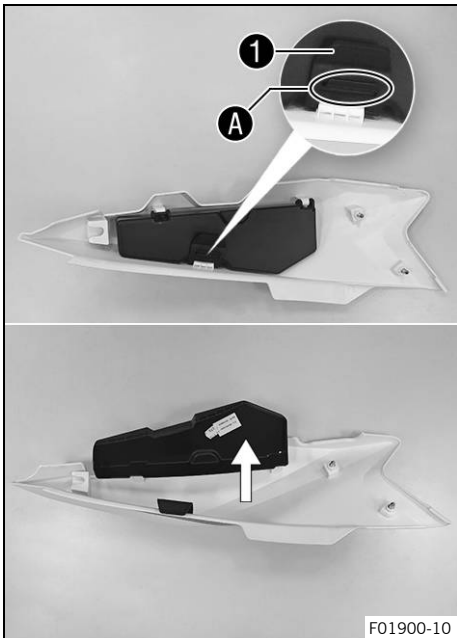

3.10 Closing the storage compartment on the right

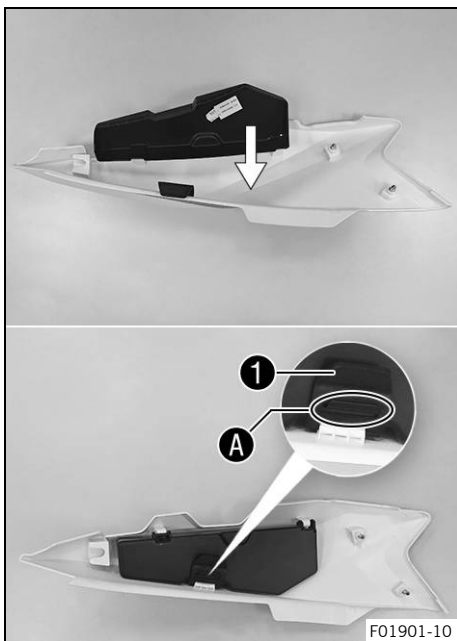

Main work

- Close the storage compartment.
- Raise elastic fastener ① and hang up in area ②.

Finishing work

- Install the right side cover. (📖 p. 13)
- Mount the seat. (📖 p. 10)



3.11 Installing the right side cover

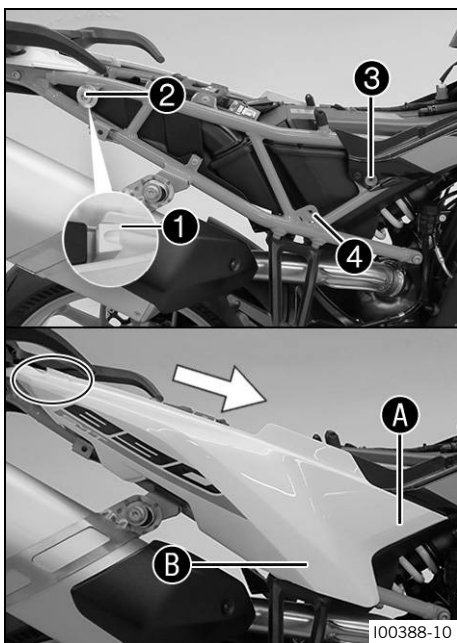

Main work

- Position the right side cover with holding lug ① on bushing ② and push backward.
- ✓ The right side cover engages under the tail part.
- Press the right side cover in the area ③ into rubber bushing ④ and press into rubber bushing ⑤ in area ⑥.

Finishing work

- Mount the seat. (📖 p. 10)



3.12 Removing the battery cover

Preparatory work

- Remove the seat. (📖 p. 9)

Main work

- Remove screws ❶ with the bushings.
- Remove the battery cover from above.

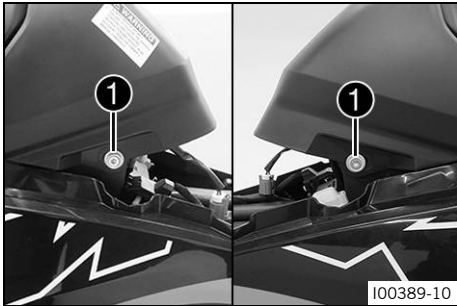

3.13 Installing the battery cover

Main work

- Position the battery cover with holding lugs ❶ on bushings ❷ and push downward.
- ✓ The battery cover engages on the left and right under the fuel tank spoiler.
- Mount screws ❸ with the bushings and tighten.

Guideline

Screw, seat fixing	M6	6 Nm (4.4 lbf ft)
--------------------	----	-------------------

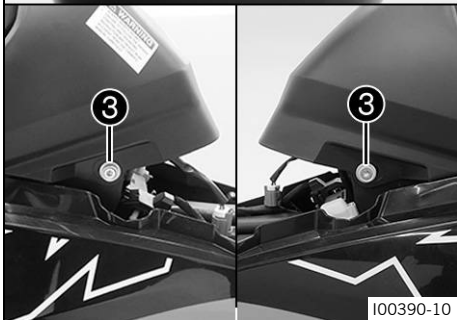
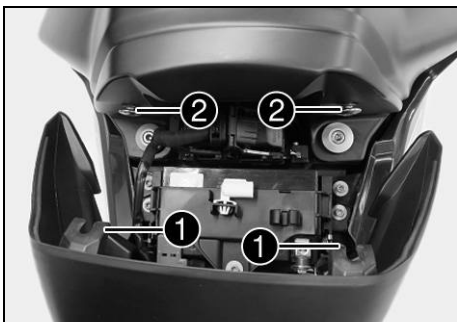

Finishing work

- Mount the seat. (📖 p. 10)

3.14 Charging the 12-V battery



Warning

Risk of injury Battery acid and battery gases cause serious chemical burns.

- Keep 12 V batteries out of the reach of children.
- Wear suitable protective clothing and safety glasses.
- Avoid contact with battery acid and battery gases.
- Keep sparks or open flames away from the 12 V battery.
- Only charge 12 V batteries in well-ventilated rooms.
- Rinse the affected area immediately with plenty of water in the event of contact with the skin.
- Rinse eyes with water for at least 15 minutes and consult a doctor immediately if battery acid and battery gases get into the eyes.



Note

Environmental hazard 12 V batteries contain environmentally hazardous materials.

- Do not dispose of 12 V batteries as household waste.
- Dispose of 12 V batteries at a collection point for used batteries.



Note

Environmental hazard Hazardous substances cause environmental damage.

- Dispose of oils, grease, filters, fuel, cleaning agents, brake fluid, etc., correctly and in compliance with the applicable regulations.



Info

Even when there is no load on the 12-V battery, it discharges steadily each day. The charging level and the method of charging are very important for the service life of the 12-V battery. Rapid recharging with a high charging current shortens the service life of the battery. If the charging current, charging voltage, and charging time are exceeded, the 12-V battery will be destroyed. If the 12-V battery is depleted from starting the vehicle repeatedly, the battery must be charged immediately. If the 12-V battery is left in a discharged state for an extended period, it will become deeply discharged and sulfating occurs, thus destroying the battery. The 12-V battery is maintenance-free, i.e. the acid level does not have to be checked.

Preparatory work

- Remove the seat. (📖 p. 9)
- Disconnect the negative cable of the 12-V battery. (📖 p. 16)

Main work

- Connect a battery charger to the 12-V battery. Adjust the battery charger.

EU battery charger **XCharge-professional** (00029095050)

Alternative 1

US battery charger **XCharge-professional** (00029095051)

Alternative 2

UK battery charger **XCharge-professional** (00029095052)

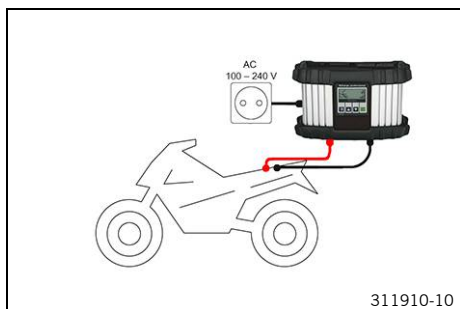

Info

Follow the instructions of the charger and the manual.

- Disconnect the battery charger after charging the 12-V battery.

Guideline

The charging current, charging voltage, and charging time must not be exceeded.	
Recharge the 12-V battery regularly when the motorcycle is not being used	6 months

Finishing work

- Connect the negative cable of the 12-V battery. (📖 p. 16)
- Mount the seat. (📖 p. 10)
- Set the time and date.



3.15 Disconnecting the negative cable of the 12-V battery



Warning

Risk of injury Battery acid and battery gases cause serious chemical burns.

- Keep 12 V batteries out of the reach of children.
- Wear suitable protective clothing and safety glasses.
- Avoid contact with battery acid and battery gases.
- Keep sparks or open flames away from the 12 V battery.
- Only charge 12 V batteries in well-ventilated rooms.
- Rinse the affected area immediately with plenty of water in the event of contact with the skin.
- Rinse eyes with water for at least 15 minutes and consult a doctor immediately if battery acid and battery gases get into the eyes.



Caution

Danger of accidents Electronic components and safety devices will be damaged if the 12-V battery is discharged or missing.

If the 12-V battery is discharged or defective, malfunctions in the vehicle electronics can occur, especially when starting.

- Never operate the vehicle with a discharged 12-V battery or without a 12-V battery.

Preparatory work

- Remove the seat. (📖 p. 9)

Main work

- Disconnect negative cable ❶ from the 12-V battery.

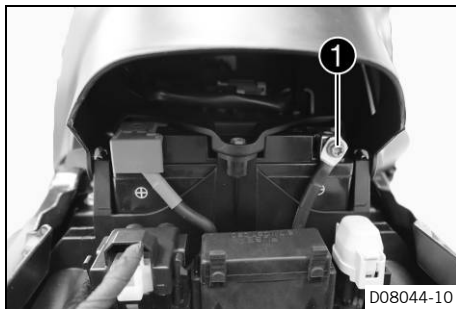

3.16 Connecting the negative cable of the 12-V battery



Warning

Risk of injury Battery acid and battery gases cause serious chemical burns.

- Keep 12 V batteries out of the reach of children.
- Wear suitable protective clothing and safety glasses.
- Avoid contact with battery acid and battery gases.
- Keep sparks or open flames away from the 12 V battery.
- Only charge 12 V batteries in well-ventilated rooms.
- Rinse the affected area immediately with plenty of water in the event of contact with the skin.
- Rinse eyes with water for at least 15 minutes and consult a doctor immediately if battery acid and battery gases get into the eyes.



Caution

Danger of accidents Electronic components and safety devices will be damaged if the 12-V battery is discharged or missing.

If the 12-V battery is discharged or defective, malfunctions in the vehicle electronics can occur, especially when starting.

- Never operate the vehicle with a discharged 12-V battery or without a 12-V battery.

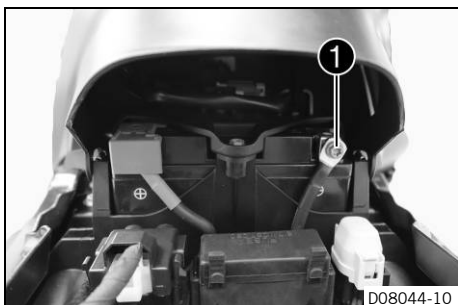

D08044-10

Main work

- Connect negative cable ① to the 12-V battery.

Guideline

Screw, battery terminal	M6	4.5 Nm (3.32 lbf ft)
-------------------------	----	-------------------------

Finishing work

- Mount the seat. (📖 p. 10)
- Set the time and date.

3.17 Installing the windshield

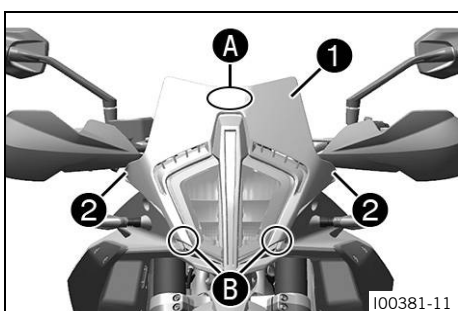

I00381-11

- Attach windshield ① in area A and area B.
- Mount and tighten screws ②.

Guideline

Remaining screws, chassis	M5	5 Nm (3.7 lbf ft)
---------------------------	----	-------------------

3.18 Removing the windshield

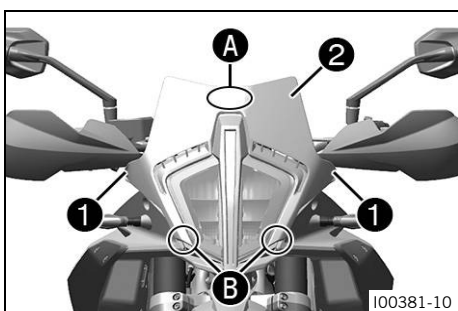

I00381-10

- Remove screws ①.
- Detach windshield ② in area A and area B.

3.19 Checking the headlight setting

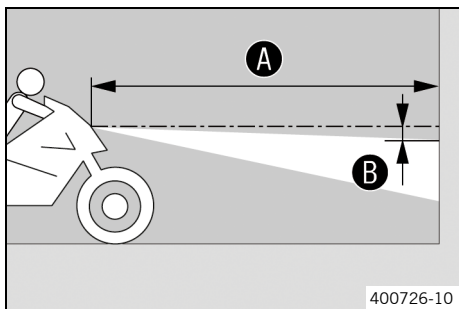

- Park the vehicle on a horizontal surface in front of a light-colored wall and make a mark at the height of the center of the low beam headlight.
- Make another mark at a distance B under the first marking.

Guideline

Distance B	5 cm (2 in)
------------	-------------

- Position the vehicle upright at distance A from the wall and switch on the low beam.

Guideline

Distance A	5 m (16 ft)
------------	-------------

- The rider now mounts the motorcycle with luggage and passenger if applicable.
- Check the headlight setting.

The light-dark boundary must be exactly on the lower marking when the motorcycle is ready to be operated with the rider mounted along with any luggage and a passenger if applicable.

- » If the boundary between light and dark does not meet specifications:
 - Adjust headlight range. (📖 p. 18)

3.20 Adjusting the headlight range

Preparatory work

- Check the headlight setting. (📖 p. 18)

Main work

- Turn adjusting screw A to adjust the headlight range.

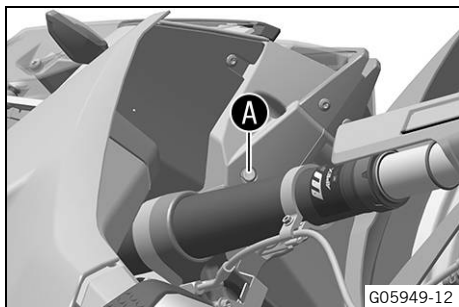

Info

Turn clockwise to reduce the headlight range; turn counterclockwise to increase the headlight range. If you have a payload, you may have to correct the headlight range.

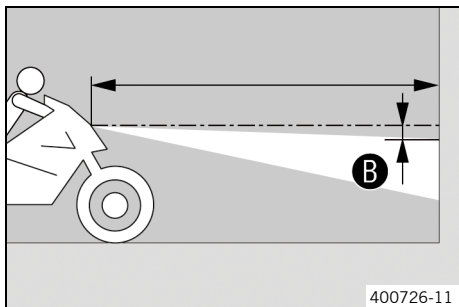

- Set the headlight to marking B.

Guideline

The light-dark boundary must lie exactly on lower marking B when the motorcycle is ready to operate with the rider mounted along with any luggage and a passenger, if applicable.

3.21 Installing the left tank guard

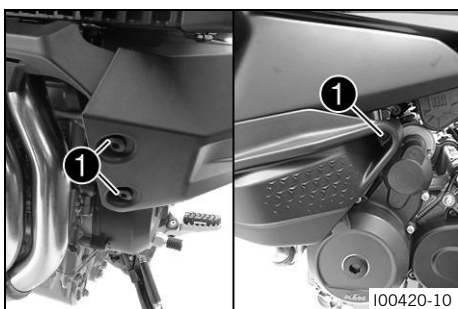

- Position the tank guard.
- Mount and tighten screws ①.

Guideline

Screw, trim	M5	3 Nm (2.2 lbf ft)
-------------	----	-------------------

3.22 Removing the left tank guard

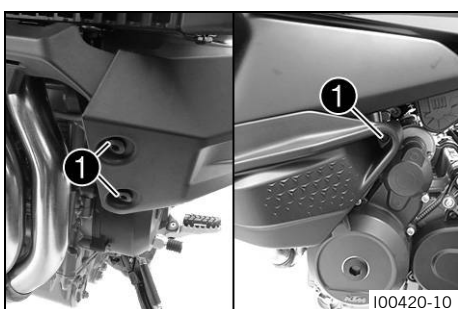

- Remove screw ①.
- Remove the tank guard.

3.23 Installing the right tank guard

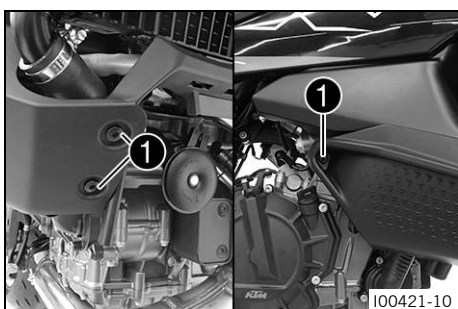

- Position the tank guard.
- Mount and tighten screws ①.

Guideline

Screw, trim	M5	3 Nm (2.2 lbf ft)
-------------	----	-------------------

3.24 Removing the right tank guard

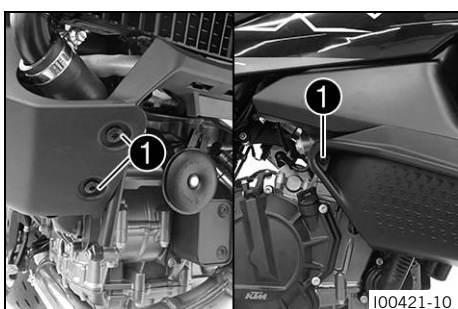

- Remove screw ①.
- Remove the tank guard.

3.25 Refueling



Danger

Fire hazard Fuel is highly flammable.

The fuel in the fuel tank expands when warm and can escape if overfilled.

- Do not fuel the vehicle in the vicinity of open flames or lit cigarettes.
- Switch off the engine for refueling.
- Make sure that no fuel is spilled; particularly not on hot parts of the vehicle.
- If any fuel is spilled, wipe it off immediately.
- Observe the specifications for refueling.



Warning

Danger of poisoning Fuel is harmful to health.

- Avoid skin, eye and clothing contact with fuel.
- Immediately consult a doctor if you swallow fuel.
- Do not inhale fuel vapors.
- Rinse the affected area immediately with plenty of water in the event of contact with the skin.
- Rinse the eyes thoroughly with water, and consult a doctor in case of fuel contact with the eyes.
- Change your clothing if fuel spills on them.

Note

Material damage Inadequate fuel quality causes the fuel filter to quickly become clogged.

In some countries and regions, the available fuel quality and cleanliness may not be sufficient. This will result in problems with the fuel system.

- Refuel only with clean fuel that meets the specified standards.



Note

Environmental hazard Improper handling of fuel is a danger to the environment.

- Do not allow fuel to enter the groundwater, the soil, or the sewage system.

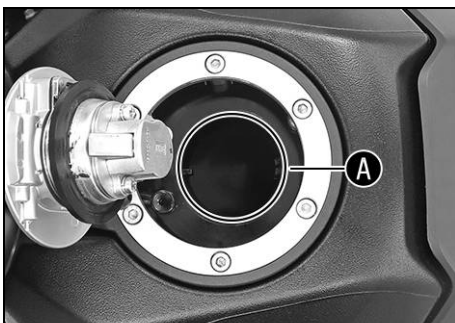

- Switch off the engine.
- Open the fuel tank filler cap. (📖 p. 21)
- Fill the fuel tank with fuel up to the lower edge **A** of the filler neck.

Total fuel tank capacity, approx.	15.8 l (4.17 US gal)	Super unleaded (ROZ 95) (📖 p. 28)
-----------------------------------	-------------------------	--------------------------------------

- Close the fuel tank filler cap. (📖 p. 21)



F03291-10

3.26 Opening the fuel tank filler cap



Danger

Fire hazard Fuel is highly flammable.

The fuel in the fuel tank expands when warm and can escape if overfilled.

- Do not fuel the vehicle in the vicinity of open flames or lit cigarettes.
- Switch off the engine for refueling.
- Make sure that no fuel is spilled; particularly not on hot parts of the vehicle.
- If any fuel is spilled, wipe it off immediately.
- Observe the specifications for refueling.



Warning

Danger of poisoning Fuel is harmful to health.

- Avoid skin, eye and clothing contact with fuel.
- Immediately consult a doctor if you swallow fuel.
- Do not inhale fuel vapors.
- Rinse the affected area immediately with plenty of water in the event of contact with the skin.
- Rinse the eyes thoroughly with water, and consult a doctor in case of fuel contact with the eyes.
- Change your clothing if fuel spills on them.
- Keep fuels correctly in a suitable canister, and out of the reach of children.



Note

Environmental hazard Improper handling of fuel is a danger to the environment.

- Do not allow fuel to enter the groundwater, the soil, or the sewage system.

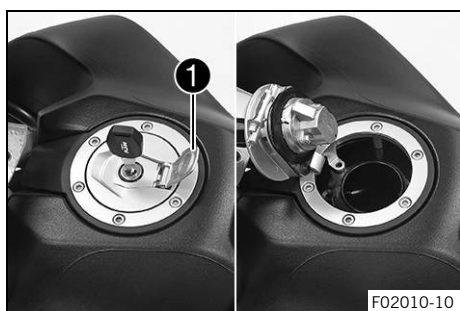

- Lift cover ① of the fuel tank filler cap and insert the ignition key into the lock.

Note

Danger of damage The ignition key may break if overloaded. Damaged ignition keys must be replaced.

- Push down on the fuel tank filler cap to take pressure off the ignition key.
- Turn the ignition key 90° clockwise.
- Lift the fuel tank filler cap.



3.27 Closing the fuel tank filler cap



- Fold down the fuel tank filler cap.
- Turn the ignition key 90° clockwise.
- Push down the fuel tank filler cap and turn the ignition key counterclockwise until the lock closes.



Warning

Fire hazard Fuel is highly flammable and a health hazard.

- Check that the fuel tank filler cap is locked correctly after closing.
- Change your clothing if fuel spills on them.
- Rinse the affected area immediately with plenty of water in the event of contact with the skin.

- Remove the ignition key and close the cover.



4.1 chassis tightening torques

Brake fluid reservoir cover, front	-	2 Nm (1.5 lbf ft)
Brake fluid reservoir cover, rear	-	1.5 Nm (1.11 lbf ft)
Compensating tank cover	-	1.1 Nm (0.81 lbf ft)
Nut, valve	ISO 10V2	12 Nm (8.9 lbf ft) Loctite®2701™
Remaining screws, chassis	EJOTPT® K45x12	1 Nm (0.7 lbf ft)
Remaining screws, chassis	EJOTPT® K50x12	1 Nm (0.7 lbf ft)
Remaining screws, chassis	EJOTPT® K50x14	1 Nm (0.7 lbf ft)
Remaining screws, chassis	EJOTPT® K50x16	2 Nm (1.5 lbf ft)
Remaining screws, chassis	EJOTPT® K50x18	2 Nm (1.5 lbf ft)
Screw, inside cover on radiator	EJOT PT® K50x18	4.5 Nm (3.32 lbf ft)
Screw, tail light	EJOT DELTA PT® 45x12-Z	1.5 Nm (1.11 lbf ft)
Socket for electrical accessories	-	4 Nm (3 lbf ft)
Throttle valve body hose clamp	-	2.8 Nm (2.07 lbf ft)
Remaining nuts, chassis	M4	3 Nm (2.2 lbf ft)
Remaining screws, chassis	M4	3 Nm (2.2 lbf ft)
Screw, fixed grip, left	M4	3 Nm (2.2 lbf ft)
Remaining nuts, chassis	M5	5 Nm (3.7 lbf ft)
Remaining screws, chassis	M5	5 Nm (3.7 lbf ft)
Screw for throttle grip	M5	3.5 Nm (2.58 lbf ft)
Screw, air filter box	M5	3 Nm (2.2 lbf ft)
Screw, brake fluid reservoir for rear brake	M5	5 Nm (3.7 lbf ft) Loctite®243™
Screw, brake line holder on link fork	M5	1 Nm (0.7 lbf ft)
Screw, combination instrument	M5	1 Nm (0.7 lbf ft)
Screw, combination switch, left	M5	2 Nm (1.5 lbf ft)
Screw, combination switch, right	M5	5 Nm (3.7 lbf ft)
Screw, engine sprocket cover	M5	5 Nm (3.7 lbf ft) Loctite®243™
Screw, fender	M5	3 Nm (2.2 lbf ft)
Screw, foot brake lever stub	M5	10 Nm (7.4 lbf ft) Loctite®243™
Screw, fork protector	M5x12	5 Nm (3.7 lbf ft)
Screw, fork protector	M5x17	5 Nm (3.7 lbf ft)
Screw, fuel level sensor	M5	3 Nm (2.2 lbf ft)
Screw, fuel tank insert	M5	3 Nm (2.2 lbf ft)
Screw, headlight bracket cover	M5	3.5 Nm (2.58 lbf ft)
Screw, headlight mask	M5	3.5 Nm (2.58 lbf ft)
Screw, heat guard	M5	5 Nm (3.7 lbf ft) Loctite®243™
Screw, instrument support on mask support, front	M5	5 Nm (3.7 lbf ft)
Screw, instrument support on mask support, rear	M5	5 Nm (3.7 lbf ft)

4 TECHNICAL SPECIFICATIONS

Screw, license plate holder	M5	5 Nm (3.7 lbf ft)	Loctite®243™
Screw, lower rear panel	M5	3 Nm (2.2 lbf ft)	
Screw, mask support	M5	5 Nm (3.7 lbf ft)	
Screw, mask support cover	M5	3.5 Nm (2.58 lbf ft)	
Screw, side stand sensor	M5	2 Nm (1.5 lbf ft)	Loctite®243™
Screw, splash protector	M5	2.8 Nm (2.07 lbf ft)	
Screw, trim	M5	3 Nm (2.2 lbf ft)	
Spoke nipple	M5	6 Nm (4.4 lbf ft)	
Battery cover attachment screw	M6	5 Nm (3.7 lbf ft)	
Brake cylinder screw on the rear brake system	M6	10 Nm (7.4 lbf ft)	Loctite®243™
Hand guard fitting	M6	6 Nm (4.4 lbf ft)	
Nut, foot brake lever adjustment	M6	6 Nm (4.4 lbf ft)	
Nut, hand brake lever	M6	Attach torque to nut. 6 Nm (4.4 lbf ft)	
Nut, push rod, foot brake lever	M6	6 Nm (4.4 lbf ft)	
Nut, shift rod	M6	6 Nm (4.4 lbf ft)	
Nut, shift rod	M6LH	6 Nm (4.4 lbf ft)	
Remaining nuts, chassis	M6	10 Nm (7.4 lbf ft)	
Remaining screws, chassis	M6	10 Nm (7.4 lbf ft)	
Screw activated carbon filter on retaining bracket	M6	8 Nm (5.9 lbf ft)	
Screw cap, fuel tank cover	M6	8 Nm (5.9 lbf ft)	
Screw, 6-D sensor	M6	5 Nm (3.7 lbf ft)	
Screw, ABS module	M6	8 Nm (5.9 lbf ft)	
Screw, ball joint of push rod on brake cylinder	M6	6 Nm (4.4 lbf ft)	Loctite®243™
Screw, battery holding bracket	M6	4.5 Nm (3.32 lbf ft)	
Screw, battery terminal	M6	4.5 Nm (3.32 lbf ft)	
Screw, brace for mask support center part	M6	3 Nm (2.2 lbf ft)	Loctite®243™
Screw, brake assembly	M6	5 Nm (3.7 lbf ft)	
Screw, cable on starter motor	M6	5 Nm (3.7 lbf ft)	
Screw, cable on starter relay	M6	4.5 Nm (3.32 lbf ft)	
Screw, clutch assembly	M6	5 Nm (3.7 lbf ft)	
Screw, cross member in rear	M6x13	10 Nm (7.4 lbf ft)	Loctite®243™
Screw, cross member in rear	M6x12	6 Nm (4.4 lbf ft)	Loctite®243™
Screw, exhaust clamp on main silencer	M6	8 Nm (5.9 lbf ft)	
Screw, footrest bracket, rear	M6	9 Nm (6.6 lbf ft)	Loctite®243™
Screw, front wheel speed sensor	M6	6 Nm (4.4 lbf ft)	
Screw, fuel pump	M6	6 Nm (4.4 lbf ft)	
Screw, fuel tank clamp	M6	3 Nm (2.2 lbf ft)	

Screw, fuel tank spoiler attachment	M6	4 Nm (3 lbf ft)
Screw, fuel tap	M6	6 Nm (4.4 lbf ft)
Screw, ground wire on frame	M6	6 Nm (4.4 lbf ft)
Screw, ground wire on starter motor	M6	10 Nm (7.4 lbf ft)
Screw, ignition lock (tamper-proof screw)	M6	Tighten until the head tears off. Loctite®243™
Screw, magnetic holder on side stand	M6	2 Nm (1.5 lbf ft) Loctite®243™
Screw, mask support on frame	M6	10 Nm (7.4 lbf ft) Loctite®243™
Screw, mask support on steering head	M6	10 Nm (7.4 lbf ft) Loctite®243™
Screw, presilencer exhaust clamp	M6	8 Nm (5.9 lbf ft) Copper paste
Screw, radiator bracket, bottom	M6	5 Nm (3.7 lbf ft)
Screw, rear wheel speed sensor	M6	6 Nm (4.4 lbf ft)
Screw, seat fixing	M6	6 Nm (4.4 lbf ft)
Screw, seat lock	M6	10 Nm (7.4 lbf ft) Loctite®243™
Screw, shift rod	M6	10 Nm (7.4 lbf ft) Loctite®243™
Screw, shift shaft deflector on shift shaft	M6	10 Nm (7.4 lbf ft) Loctite®243™
Screw, voltage regulator	M6	6 Nm (4.4 lbf ft)
Foot brake lever, fitting	M8	25 Nm (18.4 lbf ft) Loctite®2701™
Hand guard screw	M8	25 Nm (18.4 lbf ft)
Nut, rear sprocket screw	M8	35 Nm (25.8 lbf ft) Loctite®2701™
Pin, rear brake caliper	M8	22 Nm (16.2 lbf ft) Loctite®243™
Remaining nuts, chassis	M8	25 Nm (18.4 lbf ft)
Remaining screws, chassis	M8	25 Nm (18.4 lbf ft)
Screw, bottom triple clamp	M8	12 Nm (8.9 lbf ft)
Screw, engine fixing arm linkage bracket	M8	25 Nm (18.4 lbf ft) Loctite®243™
Screw, foot brake lever return spring bolt	M8	12 Nm (8.9 lbf ft) Loctite®2701™
Screw, fork stub	M8	15 Nm (11.1 lbf ft)
Screw, front brake caliper	M8	25 Nm (18.4 lbf ft)
Screw, front brake disc	M8	28 Nm (20.7 lbf ft) Loctite®243™
Screw, grab handle	M8	25 Nm (18.4 lbf ft) Loctite®243™
Screw, handlebar clamp	M8	20 Nm (14.8 lbf ft)
Screw, main silencer fastening	M8	15 Nm (11.1 lbf ft)

4 TECHNICAL SPECIFICATIONS

Screw, main silencer holder	M8	25 Nm (18.4 lbf ft)	
Screw, passenger seat bracket	M8	25 Nm (18.4 lbf ft)	Loctite®243™
Screw, presilencer on frame	M8	15 Nm (11.1 lbf ft)	Loctite®243™
Screw, rear brake disc	M8	28 Nm (20.7 lbf ft)	Loctite®243™
Screw, rear footrest bracket	M8	25 Nm (18.4 lbf ft)	Loctite®243™
Screw, shift lever	M8	25 Nm (18.4 lbf ft)	Loctite®2701™
Screw, spring holder plate on side stand bracket	M8	15 Nm (11.1 lbf ft)	Loctite®2701™
Screw, steering damper on holder	M8	8 Nm (5.9 lbf ft)	Loctite®243™
Screw, steering damper on triple clamp	M8	8 Nm (5.9 lbf ft)	Loctite®243™
Screw, steering stem	M8	20 Nm (14.8 lbf ft)	Loctite®243™
Screw, subframe	M8	25 Nm (18.4 lbf ft)	Loctite®243™
Screw, top triple clamp	M8	15 Nm (11.1 lbf ft)	
Securing bolt for brake linings	M8	10 Nm (7.4 lbf ft)	
Remaining nuts, chassis	M10	45 Nm (33.2 lbf ft)	
Remaining screws, chassis	M10	45 Nm (33.2 lbf ft)	
Screw, engine bracket	M10	45 Nm (33.2 lbf ft)	Loctite®243™
Screw, front footrest bracket	M10x30	45 Nm (33.2 lbf ft)	Loctite®243™
Screw, front footrest bracket	M10x40	45 Nm (33.2 lbf ft)	Loctite®243™
Screw, front footrest bracket	M10x65	45 Nm (33.2 lbf ft)	Loctite®243™
Screw, handlebar support	M10	45 Nm (33.2 lbf ft)	Loctite®243™
Screw, side stand	M10	40 Nm (29.5 lbf ft)	Loctite®243™
Screw, subframe	M10	50 Nm (36.9 lbf ft)	Loctite®243™
Banjo bolt, brake line	M10x1	25 Nm (18.4 lbf ft)	
Nut, turn signal	M10x1.25	4 Nm (3 lbf ft)	
Screw, front brake caliper	M10x1.25	45 Nm (33.2 lbf ft)	Loctite®243™
Screw, bottom shock absorber	M12	80 Nm (59 lbf ft)	Loctite®2701™
Screw, swingarm pivot	M12	100 Nm (73.8 lbf ft)	
Screw, top shock absorber	M12	80 Nm (59 lbf ft)	Loctite®2701™
Lambda sensor	M18x1.5	50 Nm (36.9 lbf ft)	

Bushing, shock absorber support	M20LHx1.5	10 Nm (7.4 lbf ft) Thread and fitting greased
Screw, steering head	M20x1.5	18 Nm (13.3 lbf ft)
Nut, rear wheel spindle	M25x1.5	90 Nm (66.4 lbf ft) Thread and contact area of wheel spindle greased
Screw, front wheel spindle	M25x1.5	45 Nm (33.2 lbf ft) Thread greased

Super unleaded (ROZ 95)

Standard/classification

- DIN EN 228 (ROZ 95)

Guideline

- Only use super unleaded fuel that matches or is equivalent to the specified standard.
- Fuel with an ethanol content of up to 10% (E10 fuel) is safe to use.



Info

Do **not** use fuel containing methanol (e.g., M15, M85, M100) or more than 10% ethanol (e.g., E15, E25, E85, E100).



3240022en

21.12.2023

