

**350 EXC-F**  
**350 EXC-F CHAMPION EDITION**  
**350 XW-F**  
**350 EXC-F SIX DAYS**

ITEM NO.: 3240049EN





Congratulations on your decision to purchase a KTM motorcycle. You are now the owner of a state-of-the-art, sporty motorcycle that you will continue to enjoy for a long time if you maintain it properly.

We wish you good and safe riding at all times!

You can enter the serial numbers of your vehicle below to find the serial numbers more quickly if required:

<u>Vehicle identification number</u>	Dealer stamp
<u>Engine number  (p. 18)</u>	

The Owner's Manual contained the latest information for this model series at the time of publication. Slight deviations resulting from continuing development and design of the motorcycles cannot, however, be completely excluded.

All specifications are non-binding. KTM Sportmotorcycle GmbH specifically reserves the right to modify or delete technical specifications, prices, colors, forms, materials, services, designs, equipment, etc., without prior notice and without specifying reasons, to adapt these to local conditions, as well as to stop production of a particular model without prior notice. KTM accepts no liability for delivery options, differences from illustrations and descriptions, misprints, and other errors. The models portrayed partly contain special equipment that does not belong to the regular scope of delivery.

© 2024 KTM Sportmotorcycle GmbH, Mattighofen Austria

All rights reserved. Figures: Mitterbauer / Visus Studios / KISKA / KTM

Written permission from the copyright owner is required before any duplication or reproduction.

**ISO 9001**

KTM applies quality assurance processes that lead to the highest possible product quality as defined in the ISO 9001 international quality management standard.



12 100 6061

**Issuing institution:**

TÜV SÜD Management Service GmbH

KTM Sportmotorcycle GmbH  
Stallhofnerstraße 3  
5230 Mattighofen, Austria











This document is valid for the following models:

- 350 EXC-F EU (F8203Y9)
- 350 EXC-F BR (F8240Y9)
- 350 EXC-F AR (F8242Y9)
- 350 EXC-F CHAMPION EDITION EU (F8203YA)
- 350 XW-F US (F8275Y4)
- 350 EXC-F SIX DAYS EU (F8203Y2)
- 350 EXC-F SIX DAYS BR (F8240Y2)









# Table of contents

1	Means of representation.....	9	6.8	Electric starter .....	21
1.1	Conventions.....	9	6.9	Kill switch .....	21
1.1.1	Icons .....	9	6.10	Combination switch ( <b>All special models</b> ) .....	21
1.1.2	Formatting .....	9	6.11	Overview of indicator lights ( <b>All EU / AR / BR models</b> ) .....	22
1.1.3	Abbreviations .....	9	6.12	Overview of indicator lights ( <b>XW-F</b> ).....	22
2	Safety .....	10	6.13	Opening the fuel tank cap .....	23
2.1	Safety instructions .....	10	6.14	Closing the fuel tank cap .....	23
2.2	Warning against tampering with the machine .....	10	6.15	Cold start button .....	24
2.3	Safe use .....	11	6.16	Idle speed adjustment screw .....	24
2.4	Protective clothing .....	11	6.17	Gear shift lever .....	25
2.5	Work rules .....	11	6.18	Brake pedal .....	25
2.6	Environment .....	12	6.19	Side stand .....	25
2.7	Owner's manual .....	12	6.20	Steering lock ( <b>All EU models / AR</b> ) .....	26
2.8	Use definition – intended use .....	12	6.21	Locking the steering ( <b>All EU models / AR</b> ) .....	26
2.9	Improper use .....	13	6.22	Unlocking the steering ( <b>All EU models / AR</b> ).....	27
3	Important notes .....	14	7	Dashboard .....	28
3.1	Manufacturer's warranty, implied warranty .....	14	7.1	Combination instrument overview .....	28
3.2	Auxiliary material, operating material .....	14	7.2	activation and testing .....	28
3.3	Spare parts, accessories .....	14	7.2.1	Activating combination instrument .....	28
3.4	Service .....	14	7.2.2	Display test .....	28
3.5	Figures .....	14	7.2.3	<b>WS</b> (wheel size) .....	29
3.6	Customer service .....	14	7.3	Setting kilometers or miles .....	29
4	View of the vehicle .....	15	7.4	Setting the combination instrument .....	30
4.1	View of vehicle, left side (example) .....	15	7.5	Setting the clock .....	30
4.2	View of vehicle, right side (example) .....	16	7.6	Viewing the lap time .....	31
5	Serial number .....	17	7.7	Display mode <b>SPEED</b> (speed) .....	31
5.1	Vehicle identification number .....	17	7.8	Display mode <b>SPEED/H</b> (operating hours) .....	31
5.2	Type approval label .....	17	7.9	Setup menu .....	32
5.3	Key number .....	18	7.10	Adjusting the unit of measurement .....	33
5.4	Engine number .....	18	7.11	Display mode <b>SPEED/CLK</b> (time) .....	33
5.5	Fork part number .....	18	7.12	Setting the clock .....	34
5.6	Shock absorber part number .....	18	7.13	Display mode <b>SPEED/LAP</b> (lap time) .....	34
6	Controls .....	19	7.14	Viewing the lap time .....	35
6.1	Clutch lever .....	19	7.15	Display mode <b>SPEED/ODO</b> (odometer) .....	35
6.2	Handbrake lever .....	19	7.16	Display mode <b>SPEED/TR1</b> (trip master 1) .....	36
6.3	Throttle grip .....	19	7.17	Display mode <b>SPEED/TR2</b> (trip master 2) .....	36
6.4	Horn button ( <b>All EU / AR / BR models</b> ) .....	19	7.18	Adjusting <b>TR2</b> (trip master 2) .....	37
6.5	Light switch ( <b>All EU / AR / BR models</b> ) .....	20	7.19	Display mode <b>SPEED/A1</b> (average speed 1) .....	38
6.6	Light switch ( <b>XW-F</b> ) .....	20			
6.7	Turn signal switch ( <b>All EU / AR / BR models</b> ) .....	20			

7.20	Display mode <b>SPEED/A2</b> (average speed 2) .....	38	11.4	Adjusting the high-speed compression damping of the shock absorber .....	56
7.21	Display mode <b>SPEED/S1</b> (stop watch 1) .....	39	11.5	Adjusting the rebound damping of the shock absorber .....	56
7.22	Display mode <b>SPEED/S2</b> (stop watch 2) .....	39	11.6	Measuring the dimension of the unloaded rear wheel .....	57
8	Preparing for use .....	40	11.7	Checking the static sag of the shock absorber .....	58
8.1	Notes on preparing for first use. ....	40	11.8	Checking the rider sag of the shock absorber .....	58
8.2	Running in the engine .....	41	11.9	Adjusting the preload for the shock absorber  .....	59
8.3	Starting performance of lithium-ion batteries at low temperatures .....	41	11.10	Adjusting the rider sag  .....	60
8.4	Preparing the vehicle for difficult operating conditions .....	42	11.11	Checking the basic setting of the fork .....	60
8.5	Preparing the vehicle for rides on dry sand .....	42	11.12	Adjusting the compression damping of the fork .....	61
8.6	Preparing the vehicle for rides on wet sand .....	43	11.13	Adjusting the rebound damping of the fork .....	61
8.7	Preparing for rides on wet and muddy surfaces .....	43	11.14	Handlebar position .....	62
8.8	Preparing vehicle for rides at high temperature or slow speed .....	44	11.15	Adjusting the handlebar position  .....	63
8.9	Preparing the vehicle for low temperatures or snow .....	44	12	Service work on the chassis .....	65
9	Riding instructions .....	45	12.1	Raising the motorcycle with a lift stand .....	65
9.1	Checks and maintenance measures when preparing for use .....	45	12.2	Removing the motorcycle from the lift stand .....	65
9.2	Starting the vehicle .....	45	12.3	Bleeding the fork legs .....	65
9.3	Activating traction control ( <b>All BR-models</b> ) .....	46	12.4	Cleaning the dust boots of the fork legs .....	66
9.4	Starting off .....	47	12.5	Removing the fork protector .....	67
9.5	Quickshifter ( <b>EXC-F BR / EXC-F SIX DAYS</b> ) .....	47	12.6	Installing the fork protector .....	67
9.6	Activate the quickshifter ( <b>EXC-F BR / EXC-F SIX DAYS</b> ) .....	47	12.7	Removing the frame protector .....	67
9.7	Shifting, riding .....	48	12.8	Installing the frame protector .....	67
9.8	Braking .....	48	12.9	Removing the fork legs  .....	68
9.9	Stop, park .....	49	12.10	Installing the fork legs  .....	68
9.10	Transportation .....	49	12.11	Removing the lower triple clamp  .....	69
9.11	Refueling .....	50	12.12	Installing the lower triple clamp  .....	70
10	Service schedule .....	52	12.13	Checking the steering head bearing play .....	72
10.1	Service schedule .....	52	12.14	Adjusting the steering head bearing play  .....	73
11	Tuning the chassis .....	55	12.15	Lubricating the steering head bearing  .....	74
11.1	Checking the basic chassis setting with the rider's weight .....	55	12.16	Removing the front top fender .....	74
11.2	Compression damping of the shock absorber .....	55	12.17	Installing the front top fender .....	75
11.3	Adjusting the low-speed compression damping of the shock absorber .....	55	12.18	Removing the shock absorber  .....	75
			12.19	Installing the shock absorber  .....	76
			12.20	Removing the seat .....	78









12.21	Mounting the seat	78	13.7	Changing the brake pads of the front brake	104
12.22	Removing air filter box cover	79	13.8	Checking the free travel of the brake pedal	106
12.23	Installing air filter box cover	80	13.9	Adjusting the basic position of the brake pedal	106
12.24	Removing the air filter	80	13.10	Checking the brake fluid level for the rear brake	107
12.25	Installing the air filter	81	13.11	Adding brake fluid for the rear brake	107
12.26	Cleaning the air filter and air filter box	81	13.12	Checking that the brake pads of the rear brake are secured	109
12.27	Preparing the air filter box cover for securing	82	13.13	Changing the rear brake pads	109
12.28	Removing the muffler	82	14	Wheels, tires	112
12.29	Installing muffler	83	14.1	Removing the front wheel	112
12.30	clean spark arrestor (XW-F)	83	14.2	Installing the front wheel	113
12.31	Changing the glass fiber filling of the muffler	85	14.3	Removing the rear wheel	113
12.32	Removing the fuel tank	85	14.4	Installing the rear wheel	114
12.33	Installing the fuel tank	87	14.5	Checking the tire condition	115
12.34	Checking the chain for dirt	89	14.6	Checking the tire pressure	116
12.35	Cleaning the chain	89	14.7	Checking the spoke tension	117
12.36	Checking the chain tension	90	15	Electrics	118
12.37	Adjusting the chain tension	91	15.1	Removing the 12 V battery	118
12.38	Checking the chain, rear sprocket, front sprocket, and chain guide	92	15.2	Installing the 12 V battery	119
12.39	Checking the frame	95	15.3	Charging the 12 V battery	120
12.40	Checking the swingarm	95	15.4	Changing the main fuse	122
12.41	Checking the throttle cable routing	95	15.5	Removing the headlight mask with the headlight	123
12.42	Checking the hand grip	96	15.6	Installing the headlight mask with the headlight	124
12.43	Program the Quickshifter (EXC-F BR / EXC-F SIX DAYS)	97	15.7	Changing the headlight bulb	124
12.44	Checking/correcting the fluid level of hydraulic clutch	97	15.8	Checking the headlight setting	125
12.45	Adjusting the basic position of the clutch lever	98	15.9	Adjusting the headlight range	125
12.46	Changing the hydraulic clutch fluid	98	15.10	Changing the turn signal bulb	126
12.47	Removing the skid plate (All special models / XW-F)	99	15.11	combination instrument battery, changing	127
12.48	Installing the skid plate (All special models / XW-F)	100	15.12	Diagnostic connector	128
13	Brake system	101	15.13	OCU	128
13.1	Checking the free travel on the hand brake lever	101	16	Cooling system	129
13.2	Adjusting the free travel of the handbrake lever	101	16.1	Cooling system	129
13.3	Checking the brake discs	101	16.2	Checking the frost protection and coolant level	129
13.4	Checking the brake fluid level for the front brake	102	16.3	Checking the coolant level	130
13.5	Adding brake fluid for the front brake	102	16.4	Draining the coolant	131
13.6	Checking that the brake pads of the front brake are secured	104	16.5	Refilling the coolant	132
			16.6	Changing the coolant	133

17	Tuning the engine .....	135	22.5	Shock absorber .....	156
17.1	Checking the play in the throttle cable .....	135	22.5.1	Technical data - shock absorber .....	156
17.2	Adjusting the throttle cable play  .....	135	22.5.2	Capacities - shock absorber .....	156
17.3	Adjusting the characteristic map of the throttle response  .....	136	22.6	Tightening torque .....	156
17.4	Changing the mapping ( <b>All special models</b> ) .....	137	22.6.1	engine tightening torques .....	156
17.5	Adjusting the idle speed  .....	138	22.6.2	Chassis tightening torques .....	159
17.6	Teaching the throttle valve position .....	139	Notes .....	163	
17.7	Checking the basic position of the gear shift lever .....	139	A	Technical terms .....	163
17.8	Adjusting the basic position of the gear shift lever  .....	140	B	Fuels.....	164
18	Service work on the engine .....	141	C	Operating supplies.....	165
18.1	Changing the fuel screen  .....	141	D	Cleaning agents.....	168
18.2	Checking the engine oil level .....	142	E	Icons.....	169
18.3	Changing the engine oil and oil filter, cleaning the oil screens  .....	142	E.1	Symbol colors .....	169
18.4	Adding engine oil .....	145	E.1.1	Yellow and orange symbols .....	169
19	Cleaning, care .....	146	E.1.2	Green and blue symbols .....	169
19.1	Cleaning the motorcycle .....	146	Index .....	170	
19.2	Checks and maintenance steps for winter operation .....	147			
20	Storage .....	148			
20.1	Storage .....	148			
20.2	Preparing for use after storage .....	149			
21	Troubleshooting .....	150			
21.1	troubleshooting .....	150			
22	Technical specifications .....	152			
22.1	Engine .....	152			
22.1.1	Technical data - engine .....	152			
22.1.2	Capacities - engine .....	153			
22.2	Chassis .....	153			
22.2.1	Technical data - chassis .....	153			
22.2.2	Technical data - tires .....	154			
22.2.3	Capacities - vehicle .....	154			
22.3	Electrics .....	154			
22.3.1	Battery .....	154			
22.3.2	Fuses .....	155			
22.3.3	Lamps .....	155			
22.4	Fork .....	155			
22.4.1	Technical data - fork .....	155			
22.4.2	Capacities - fork .....	155			



## 1.1 Conventions

### 1.1.1 Icons

-  Indicates a desired result (e.g. of a work step or a function).
-  Indicates an undesired result (e.g. of a work step or a function).
-  All work marked with this symbol requires specialist knowledge and technical understanding. Ensure that this work is carried out or supervised by trained personnel from an authorized KTM workshop, and that any special tools required are used.
-  Indicates a page reference.
-  Indicates information with more details.
-  Indicates a tip, e.g. to simplify work.
-  Indicates the result from a test step.
-  Indicates the end of an activity, including any rework.

### 1.1.2 Formatting

<b>Proprietary name</b>	Indicates a proprietary name.
<b>Name<sup>®</sup></b>	Indicates a protected name.
<b>Brand<sup>™</sup></b>	Indicates a brand available on the open market.
<b><u>Underlined terms</u></b>	Refer to technical details of the vehicle or indicate technical terms that are explained in the glossary.

### 1.1.3 Abbreviations

2-pc.	2-piece
Part no.	Part number
or	respectively
approx.	circa
etc.	et cetera
poss.	possibly/possible
if necessary	if necessary
cmpl.	complete
min.	at least
no.	number
no fig.	no figure
s.	see
among others	among others/not limited to
and the like	and the like
etc.	et cetera
cf.	compare
e.g.	for example

## 2.1 Safety instructions

### Function of the safety instruction

Safety instruction brings attention to dangers when handling the product. Hazards are classified, named, described, and supplemented with information on how to avoid them.

- If there is a safety instruction before a list of instructions, the danger exists throughout the entire activity.
- If there is a safety instruction immediately before an instruction, the next step presents a danger.

### Safety instruction layout

All safety instructions are identified by a signal word and a warning symbol. The combination of signal word and warning symbol determines the degree of danger.



#### **DANGER**

Indicates an imminent danger that leads to serious injury or death.



#### **WARNING**

Indicates a potentially imminent danger that could lead to serious injury or death.



#### **CAUTION**

Indicates a potentially imminent danger that can lead to minor or slight injuries.



#### **NOTE**

Indicates a situation that can lead to damage to the product or the product environment.



#### **NOTE**

Indicates a situation that can lead to environmental damage.

## 2.2 Warning against tampering with the machine

Tampering with the noise control system is prohibited. Federal law prohibits the following acts or the causing thereof:

1. The removal or rendering inoperative by any person other than for purposes of servicing, repair, or replacement, of any device or element of design incorporated into any new vehicle for the purpose of noise control prior to its sale or delivery to the ultimate purchaser or while it is in use, or
2. the use of the vehicle after such device or element of design has been removed or rendered inoperative by any person.

Among those acts presumed to constitute tampering are the acts listed below:

1. Removing or drilling through rear mufflers, baffle plates, manifolds, or other components that conduct exhaust gases.
2. Removing or puncturing parts of the intake system.
3. Lack of proper maintenance.
4. Replacing moving parts of the vehicle, or parts of the exhaust system or intake system, with parts other than those specified by the manufacturer.

#### **(XW-F)**

An add-on or modified part must be compliant with applicable ARB evaporative emission control standards. A violation of this requirement is punishable by civil and/or criminal punishment.

## 2.3 Safe use



### DANGER

**Danger of accidents** A rider who is not fit to ride poses a danger to themselves and to others.

- Do not operate the vehicle if you are not fit to ride due to alcohol, drugs, or medication.
- Do not operate the vehicle if you are physically or mentally incapable of doing so.



### DANGER

**Danger of poisoning** Exhaust gases are toxic and inhaling them may result in unconsciousness and death.

- Always ensure that there is sufficient ventilation when running the engine.
- Use suitable exhaust extraction when starting or running the engine in an enclosed space.



### WARNING

**Danger of burns** Some vehicle components become hot when the vehicle is operated.

- Do not touch any parts such as the exhaust system, radiator, engine, damper, or brake system before the vehicle parts have cooled down.
- Allow the vehicle parts to cool down before performing any work on the vehicle.

The vehicle should only be used when it is in perfect technical condition, for its intended purpose, and in a safe and environmentally-friendly manner.

An appropriate driver's license is needed to drive the vehicle on public roads.

Have malfunctions that impair safety promptly eliminated by an authorized KTM workshop.

Observe the information and warning stickers on the vehicle.

## 2.4 Protective clothing



### WARNING

**Risk of injury** Missing or inadequate protective clothing increases the risk of injury.

- Wear appropriate protective clothing such as helmet, boots, gloves as well as pants and a jacket with protectors on all rides.
- Always wear protective clothing that is in good condition and meets the legal regulations.

## 2.5 Work rules

Unless specified otherwise, the ignition must be switched off during all work (models with ignition lock, models with transponder key) or the engine must be at a standstill (models without ignition lock or transponder key).

Special tools are required for some work. The tools are not part of the vehicle, but can be ordered using the number in parentheses. Example: bearing puller (15112017000)

Unless otherwise noted, normal conditions apply to all tasks and descriptions.

Ambient temperature	20 °C
Ambient air pressure	1,013 mbar
Relative air humidity	60 ±5 %

During assembly, use new parts to replace parts which cannot be reused (e.g. self-locking screws and nuts, expansion screws, seals, sealing rings, O-rings, pins, and lock washers).

A thread lock (e.g. **Loctite**®) is required for some screw connections. Observe the manufacturer's specific instructions for use.

If thread lock (e.g. **Precote**®) has already been applied to a new part, do not apply any additional thread lock.

After disassembly, clean the parts that are to be reused and check them for damage and wear. Replace damaged or worn parts.

After completing a repair or service, check the operating safety of the vehicle.

### 2.6 Environment

Handling the vehicle responsibly reduces the risk of conflict with other road users and the surrounding area. The future of motorcycling also depends on using motorcycles legally, being environmentally conscious and respecting the rights of others.

When disposing of used oil, other operating and auxiliary fluids, and used components, the laws and regulations of the respective country must be observed.

As motorcycles are not subject to the EU regulations governing the disposal of end-of-life vehicles, there are no legal regulations that pertain to the disposal of an end-of-life motorcycle. More information is available from authorized KTM dealers.

### 2.7 Owner's manual

Read this owner's manual carefully and in full before riding off for the first time. The owner's manual contains information and tips on how to operate, handle, and service your vehicle, as well as advice on optimum tuning and how to avoid injuries.



#### Tip

Save this owner's manual on your smartphone, for example, so that you can access it at any time.

---

An authorized KTM dealer will be happy to assist you if you are unsure.

The owner's manual is an important component of the vehicle. If the vehicle is sold, the owner's manual must be downloaded again by the new owner.

The owner's manual can be downloaded multiple times using the QR code or the link on the delivery certificate.

The owner's manual is also available for download from your authorized KTM dealer and on the KTM website. A physical copy can also be ordered from your authorized KTM dealer.

International KTM Website: <https://www.ktm.com>

### 2.8 Use definition – intended use

#### (All EU models)

This vehicle has been designed and built to withstand the typical stresses and strains of racing. This vehicle complies with the currently valid regulations and categories of the top international motorsports organizations.



#### Note

This vehicle is only authorized for operation on public roads in the homologated (restricted) version. The derestricted version of this vehicle must only be operated in closed off areas away from public highway traffic.

This vehicle is designed for use in offroad endurance competition, and not primarily for use in motocross.

---

#### (All EU / AR / BR models)

This vehicle has been designed and built to withstand the normal stresses and strains of offroad leisure use.



#### Note

This vehicle is homologated and approved for use on public roads.

No homologation-relevant components may be removed or modified.

---

#### (XW-F)

This vehicle has been designed and built to withstand the normal stresses and strains of offroad leisure use. Additionally, it fulfills the **CARB (California Air Resources Board)** guidelines of the **Green Sticker** program.

---

**Note**

This vehicle is not approved for use on public roads.  
No homologation-relevant components may be removed or modified.  
This vehicle is not designed for use in racing on closed circuits or for Motocross use.

---

**2.9 Improper use**

The vehicle may only be used as intended.

Improper use can result in danger to people, property and the environment.

Any use of the vehicle beyond the intended and defined use constitutes misuse.

Improper use includes the use of operating and auxiliary materials that do not meet the required specifications for the respective use.

## 3 Important notes

### 3.1 Manufacturer's warranty, implied warranty

The work prescribed in the service schedule must be carried out in an authorized KTM workshop only and confirmed in the electronic proof of service, since otherwise no warranty claims will be recognized. Damage or secondary damage caused by tampering with and/or conversions on the vehicle are not covered by the manufacturer's warranty.

### 3.2 Auxiliary material, operating material

Use operating materials and auxiliary materials in accordance with the operating instructions and specifications.

### 3.3 Spare parts, accessories

For safety reasons, only spare parts and accessories approved by KTM may be used. Installation must be carried out in an authorized KTM workshop. KTM accepts no liability for other products and any resulting damage or loss. Certain spare parts and accessory products are specified in parentheses in the descriptions. Authorized KTM dealers will be happy to help.

The current **KTM PowerParts** are listed for each vehicle on the KTM website.

International KTM Website: <https://www.ktm.com>

### 3.4 Service

A prerequisite for perfect operation and prevention of premature wear is that the service, care, and tuning work on the engine and chassis is properly carried out as described in the owner's manual. An incorrect suspension setting can lead to damage and breakage of chassis components.

Use of the vehicle under arduous conditions, such as on sand or on wet, dusty and muddy surfaces, can result in significantly increased wear of components, such as the powertrain, brake system, air filter, or suspension components. For this reason, it may be necessary to inspect or replace parts before the next scheduled service interval.

Please adhere to the prescribed run-in times and service intervals at all times. Strictly adhering to this will ensure a much longer service life for your motorcycle.

The relevant mileage or time interval is whichever occurs first.

### 3.5 Figures

Some of the figures in this document contain optional extras.

For clarity, some components may be shown disassembled or may not be shown at all. Disassembly is not always absolutely necessary in order to carry out the activities described. The textual information takes precedence.

### 3.6 Customer service

Authorized KTM dealers will be happy to answer questions about the vehicle and KTM.









A list of authorized KTM dealers can be found on the KTM website.

International KTM Website: <https://www.ktm.com>

## 4.1 View of vehicle, left side (example)



A002016-1

- |  |  |
|--|--|
| ① Clutch lever  (p. 19)      | ③ Fuel tank cap  |
| ② (All EU / AR / BR models)  | ④ Air filter box cover   |
| Horn button  (p. 19)        | ⑤ Side stand  (p. 25)         |
| ② (All EU / AR / BR models)  | ⑥ Engine number  (p. 18)     |
| Turn signal switch  (p. 20) | ⑦ Gear shift lever  (p. 25)  |
| ② (All EU / AR / BR models)  | ⑧ Cold start button  (p. 24) |
| Light switch  (p. 20)       |  |

## 4 View of the vehicle

### 4.2 View of vehicle, right side (example)



A002017-1

- |   |   |
|---|---|
| ❶ Shock absorber compression adjustment | ❹ Idle speed adjustment screw 📖 (p. 24) |
| ❷ Electric starter 📖 (p. 21)            | ❺ Brake pedal 📖 (p. 25)                 |
| ❸ Throttle grip 📖 (p. 19)               | ❻ Level viewer, engine oil              |
| ❹ Handbrake lever 📖 (p. 19)             | ❼ Shock absorber rebound adjuster       |
| ❺ Fork part number 📖 (p. 18)            |   |

## 5.1 Vehicle identification number

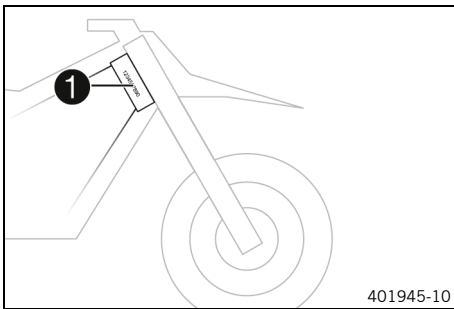

The vehicle identification number ❶ is stamped on the right-hand side of the steering head.

## 5.2 Type approval label

(All EU / AR / BR models)

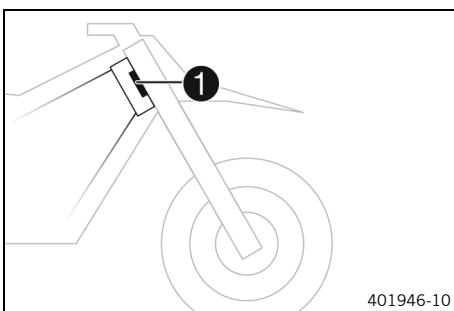

The type approval label ❶ is fixed to the front of the steering head.

(XW-F)

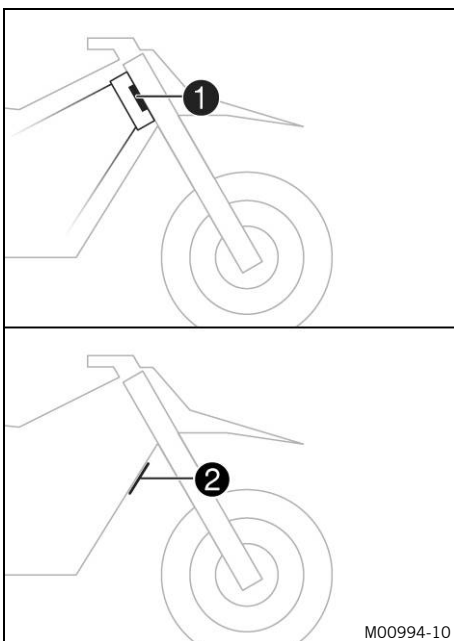

The type approval label ❶ is fixed to the front of the steering head.

The additional type label for Canada ❷ is fixed to the front of the chest tube.

## 5.3 Key number

(All EU models / AR)

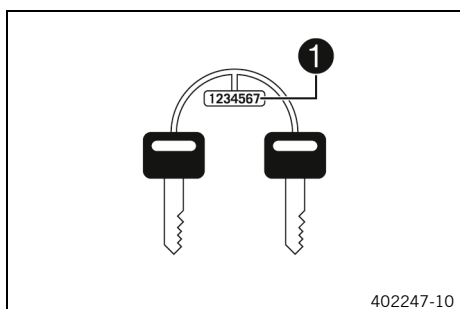

The key number ❶ for the steering lock is stamped onto the key connector.

## 5.4 Engine number

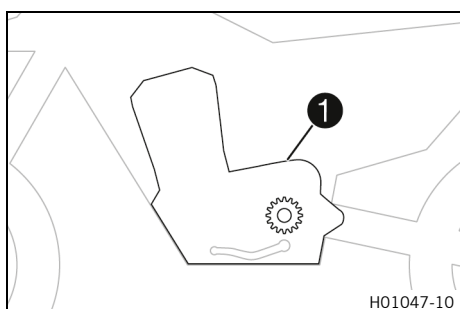

The engine number ❶ is stamped on the left side of the engine above the front sprocket.

## 5.5 Fork part number

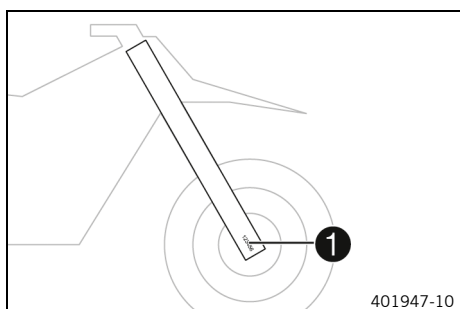

Fork part number ❶ is stamped on the inside of the fork shoe.

## 5.6 Shock absorber part number

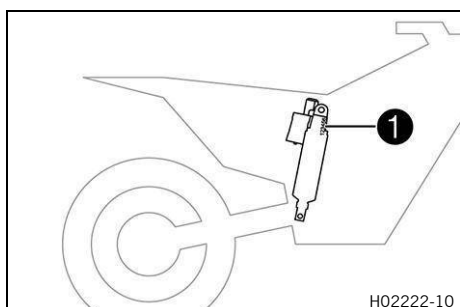

Shock absorber part number ❶ is stamped on the top right of the shock absorber.

**6.1 Clutch lever**

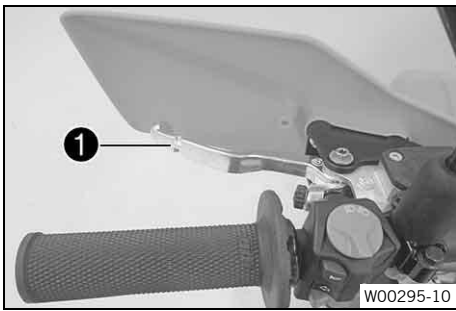

Clutch lever ❶ is fitted on the left side of the handlebar. The clutch is activated hydraulically and adjusts itself automatically.

**6.2 Handbrake lever**

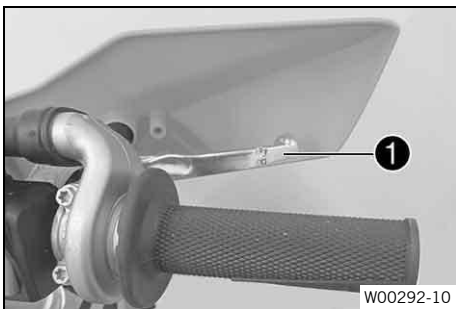

Hand brake lever ❶ is fitted on the right side of the handlebar. The front brake is engaged using the hand brake lever.

**6.3 Throttle grip**

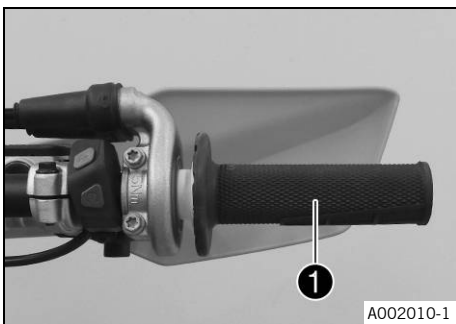



The throttle twist grip ❶ is fitted on the right side of the handlebar.

**6.4 Horn button (All EU / AR / BR models)**



Horn button ❶ is fitted on the left side of the handlebar.

Condition	Meaning
Horn buttons  in the basic position	No function
Horn buttons  pressed	The horn is operated in this position.

## 6.5 Light switch (All EU / AR / BR models)



Light switch ❶ is fitted on the left side of the handlebar.

Condition		Meaning
	Low beam on – Light switch is in the central position.	In this position, the low beam and tail light are switched on.
	High beam on – The light switch is turned counterclockwise.	In this position, the high beam and the tail light are switched on.

## 6.6 Light switch (XW-F)



The light switch ❶ is located to the left of the combination instrument.

Condition	Meaning
The tip switch is in the basic position. The light is switched off.	Light off
Light switch is pressed in until it clicks. In this position, the low beam and tail light are switched on.	Light on

## 6.7 Turn signal switch (All EU / AR / BR models)



Turn signal switch ❶ is fitted on the left side of the handlebar.

Condition		Meaning
	Turn signal switch pressed to the left	Left turn signal, on
	Turn signal switch pressed to the right	Right turn signal, on

6.8 Electric starter

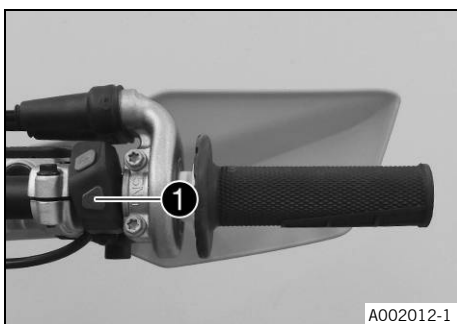

Electric starter ① is fitted on the right side of the handlebar.

Condition	Meaning
Electric starter (Ⓛ) in the basic position	No function
Electric starter (Ⓛ) pressed – The starter motor is actuated in this position.	In this position, the starter motor is actuated.

6.9 Kill switch



Kill switch ① is fitted on the right side of the handlebar.

Condition	Meaning
The kill switch is not pressed.	In this position, the ignition circuit is closed, and the engine can be started.
The kill switch is pressed and held.	In this position, the ignition circuit is interrupted, a running engine stops, and an engine at standstill will not start.

6.10 Combination switch (All special models)

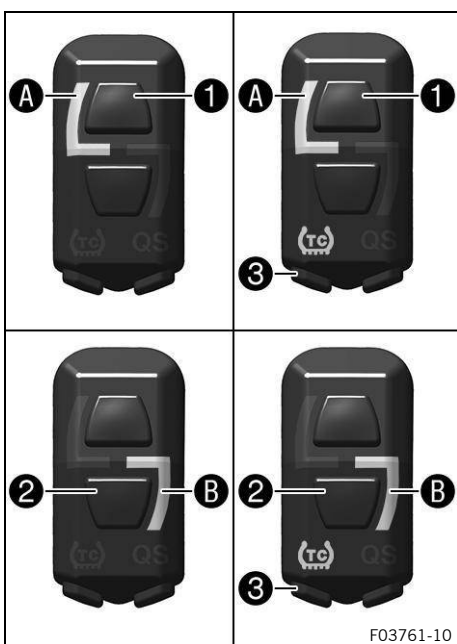

The combination switch is fitted on the left side of the handlebar.

The engine characteristic can be changed using button ① and button ② on the combination switch.

Traction control can be activated using the TC button ③ on the combination switch.

Launch control and the quickshifter can also be activated using the combination switch.

Condition	Meaning
STANDARD ①	STANDARD mapping is activated when indicator light A lights up.
STANDARD ① with TC	STANDARD mapping with traction control is activated when the indicator light A and the TC indicator light illuminate.
ADVANCED ②	ADVANCED mapping is activated when the indicator light B illuminates.
ADVANCED ② with TC	ADVANCED mapping with traction control is activated when the indicator light B and the TC indicator light illuminate.

## 6.11 Overview of indicator lights (All EU / AR / BR models)

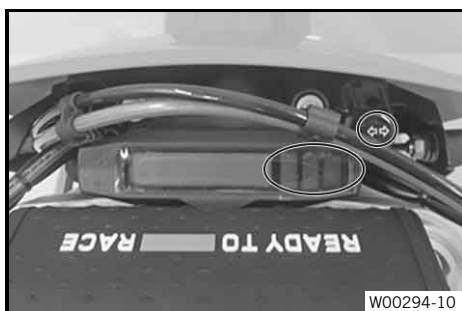

Condition		Meaning
	The high beam indicator light lights up blue.	The high beam is switched on.
	Failure indicator light lights up/flashes yellow.	The <b>OBD</b> has detected an error in the vehicle electronics. Come safely to a halt, and contact an authorized KTM workshop.
	Fuel level warning light lights up yellow.	The fuel level has reached the reserve mark.
	Turn signal indicator light flashes green.	The turn signal is switched on.

## 6.12 Overview of indicator lights (XW-F)



Condition		Meaning
	Failure indicator light lights up/flashes yellow.	The <b>OBD</b> has detected an error in the vehicle electronics. Come safely to a halt, and contact an authorized KTM workshop.
	Fuel level warning light lights up yellow.	The fuel level has reached the reserve mark.

**6.13 Opening the fuel tank cap**

**DANGER**  **Fire hazard** Fuel is highly flammable. The fuel in the fuel tank expands when warm and can escape if overfilled.

- Do not refuel the vehicle in the vicinity of open flames, glowing, or smoldering objects.
- Make sure that nobody smokes in the vicinity of the vehicle during the refueling process.
- Switch off the engine for refueling.
- Make sure that no fuel is spilled; particularly not on hot parts of the vehicle.
- If any fuel is spilled, wipe it up immediately.
- Do not overfill the fuel tank.

**WARNING**  **Danger of poisoning** Fuel is harmful to health.

- Do not allow fuel to come into contact with skin, eyes, or clothing.
- Consult a doctor immediately if fuel has been ingested.
- Do not inhale fuel vapors.
- Rinse the affected area immediately with plenty of water in the event of contact with skin.
- Rinse eyes thoroughly with water and consult a doctor immediately if fuel comes into contact with eyes.
- If fuel spills on to your clothing, change the clothing.
- Store fuel properly in a suitable container and keep out of the reach of children.

**NOTE**  **Environmental hazard** Improper handling of fuel is dangerous to the environment.

- Do not allow fuel to enter the groundwater, the soil, or the sewage system.

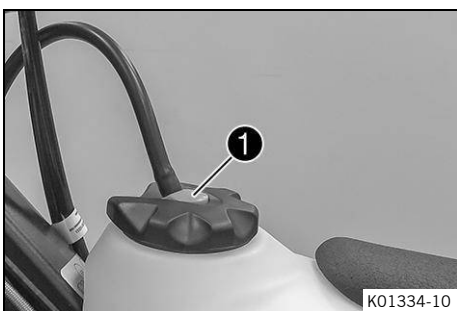

- Press release button **1**, turn the fuel tank cap counterclockwise, and lift it off.

**6.14 Closing the fuel tank cap**

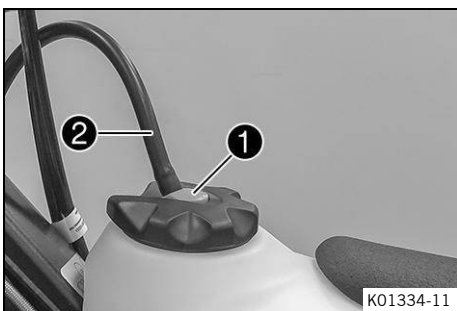

- Mount the fuel tank filler cap and turn it clockwise until release button **1** engages.

Route hose of fuel tank vent **2** without kinks.

## 6.15 Cold start button

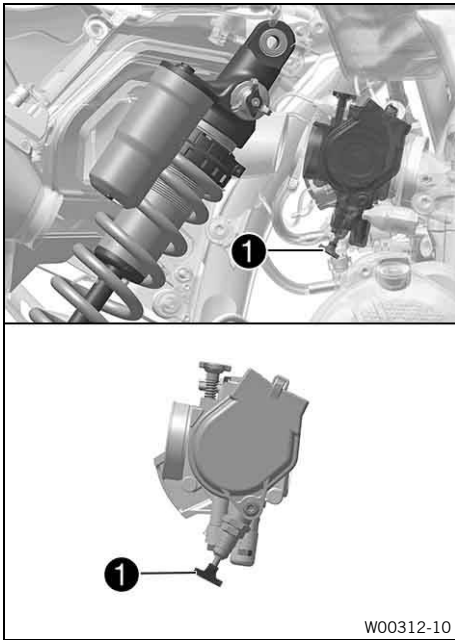

Cold start button **1** is fitted to the bottom of the throttle body. The electronic fuel injection extends the injection time when the engine is cold and the ambient temperature is low. To help the engine burn the increased amount of fuel, it must be supplied with additional oxygen by pushing the cold start button. Check whether the cold start button has returned to its basic position.

## 6.16 Idle speed adjustment screw

The idle setting of the throttle body substantially influences the vehicle's starting behavior, a stable idle speed, and the vehicle's response when the throttle is opened. An engine with a correctly set idle speed is easier to start than an engine with the idle speed set incorrectly.

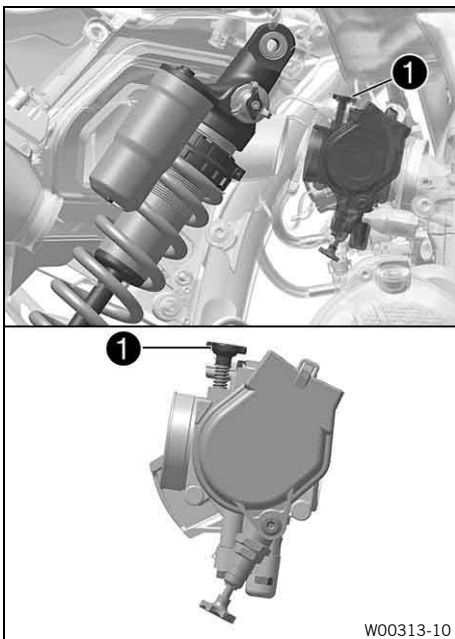

The idle speed is adjusted using idle speed adjusting screw **1**. Increase the idle speed by turning the idle speed adjustment screw clockwise. Decrease the idle speed by turning the idle speed adjustment screw counterclockwise.

**6.17 Gear shift lever**

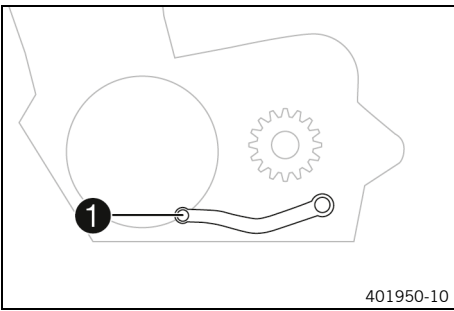

Gear shift lever ① is mounted on the left of the engine.

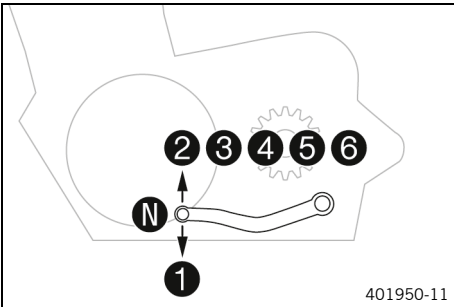

The gear positions can be seen in the figure.  
The neutral or idle position is between the first and second gears.

**6.18 Brake pedal**

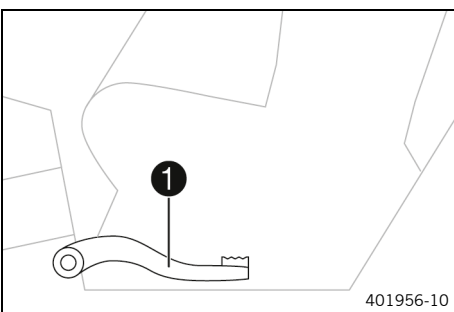

Brake pedal ① is located in front of the right footpeg.  
The rear brake is operated with the brake pedal.

**6.19 Side stand**

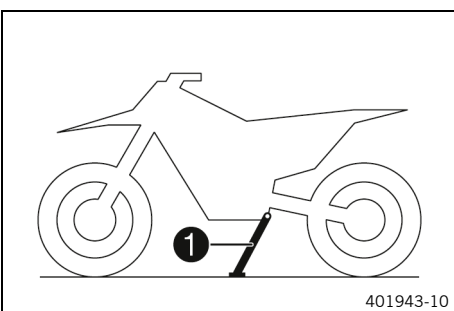

The side stand ① is attached to the left side of the vehicle.

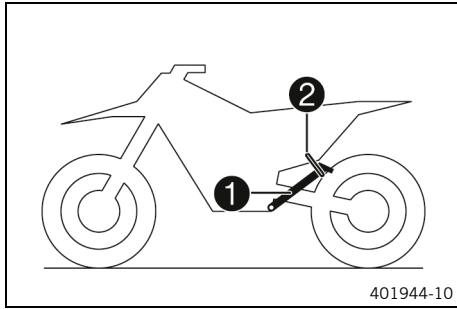

The side stand is used for parking the motorcycle.

**i Note**

When you are riding, side stand **1** must be folded up and secured with rubber band **2**.

## 6.20 Steering lock (All EU models / AR)

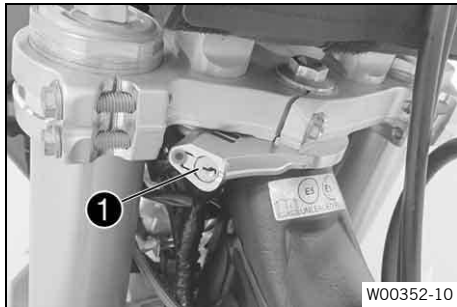

Steering lock **1** is fitted on the left side of the steering head. The steering lock is used to lock the steering. Steering and riding is then no longer possible.

## 6.21 Locking the steering (All EU models / AR)



**NOTE**

**Material damage** The vehicle may be damaged if parked incorrectly.

Damage can occur if the vehicle rolls away or falls over.

The components for parking the vehicle are designed only for the weight of the vehicle.

- Park the vehicle on a firm and level surface.
- Make sure that nobody sits on the vehicle when it is parked on a stand.

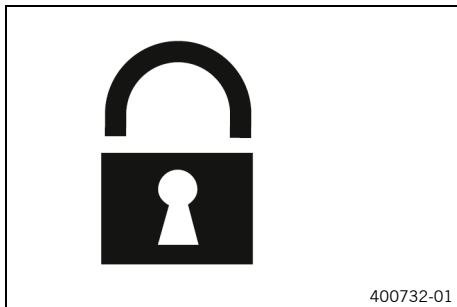

- Park the vehicle.
- Turn handlebar as far as possible to the right.
- Lubricate the steering lock regularly.

Universal oil spray (p. 165)

- Insert the key for the steering lock into the steering lock (p. 26), turn it to the left, press it in, turn it to the right and remove.

Never leave the key for the steering lock in the steering lock.

## 6.22 Unlocking the steering (All EU models / AR)

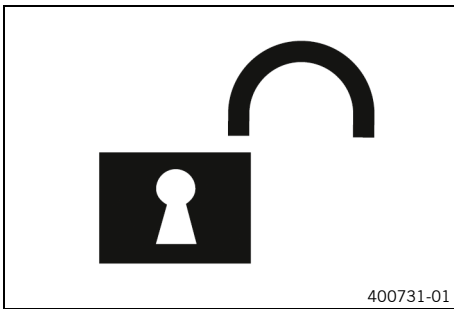



- Insert the key for the steering lock into the steering lock  (p. 26), turn it to the left, pull it out, turn it to the right and remove.

Never leave the key for the steering lock in the steering lock.

- ✓ The handlebar can now be moved again.

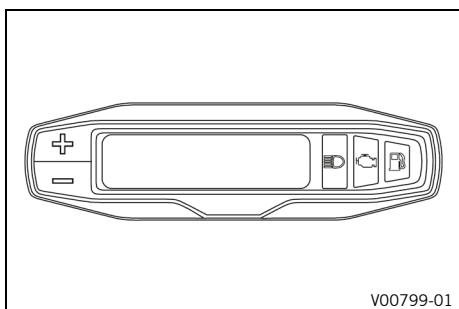
## 7.1 Combination instrument overview



- Press **button**  to control different functions.
- Press **button**  to control different functions.



### Note

When the vehicle is delivered, only the **SPEED/H** and **SPEED/ODO** display modes are activated.

## 7.2 activation and testing

### 7.2.1 Activating combination instrument

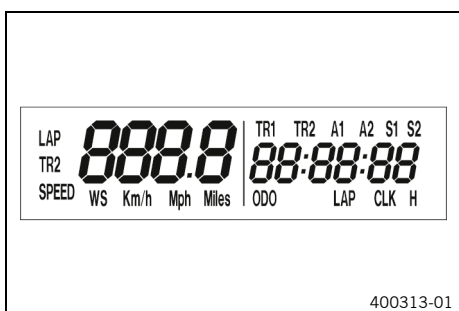

The combination instrument is activated when one of the buttons is pressed or an impulse comes from the wheel speed sensor.

### 7.2.2 Display test

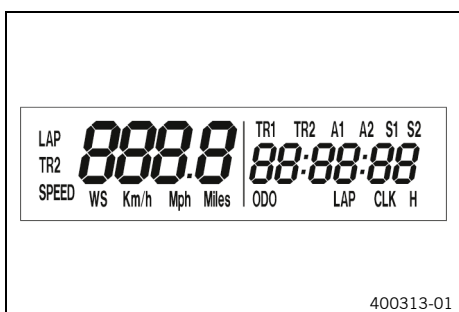

To enable you to check that the display is functioning properly, all display segments light up briefly.

### 7.2.3 WS (wheel size)



After the display function check, the wheel circumference **WS** is displayed briefly.

#### **i** Note

The number 2205 equals the circumference of the 21" front wheel with standard tires.

The indicator then changes to the last selected mode.

## 7.3 Setting kilometers or miles

#### **i** Note

If the unit is changed, value **ODO** is retained and converted accordingly. The values **TR1**, **TR2**, **A1**, **A2** and **S1** are cleared when the unit of measure is changed.

Condition: Motorcycle is stationary

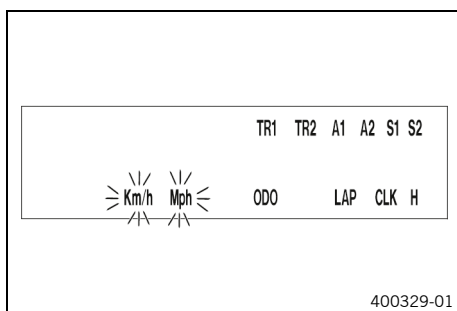

- Press button **+** briefly until indicator **H** appears in the bottom right of the display.
- Press button **+** for 2–3 seconds.
  - ✓ The Setup menu is displayed and the active functions are shown.
- Press button **+** briefly until indicator **Km/h / Mph** flashes.

- Select one of the following alternatives.

#### **Adjusting the Km/h**

- Press button **+**.

#### **Adjusting the Mph**

- Press button **-**.

- Wait 3–5 seconds.
  - ✓ The settings are stored.

#### **i** Note

When a pulse is received from the wheel speed sensor, the settings are automatically saved and the setup menu is closed.

## 7.4 Setting the combination instrument

**Note**

When the vehicle is delivered, only the **SPEED/H** and **SPEED/ODO** display modes are activated.

Condition: Motorcycle is stationary

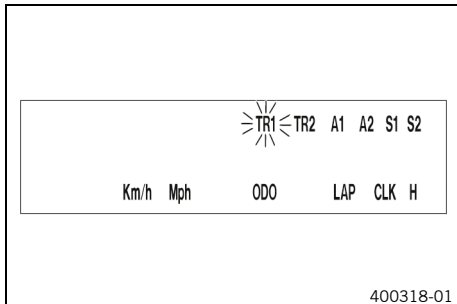

- Press button **+** briefly until indicator **H** appears in the bottom right of the display.
- Press button **+** for 2–3 seconds.
  - ✓ The Setup menu is displayed and the active functions are shown.

**Note**

When a pulse is received from the wheel speed sensor, the settings are automatically saved and the setup menu is closed.

- Press button **+** briefly until the desired function flashes.
  - ✓ The selected function flashes.
- Select one of the following alternatives.

**Activating the function**

- Press button **+**.
  - ✓ The symbol continues to appear in the display and the next function appears.

**Deactivating a function**

- Press button **-**.
  - ✓ The symbol disappears in the display and the next function appears.

## 7.5 Setting the clock

Condition: Motorcycle is stationary

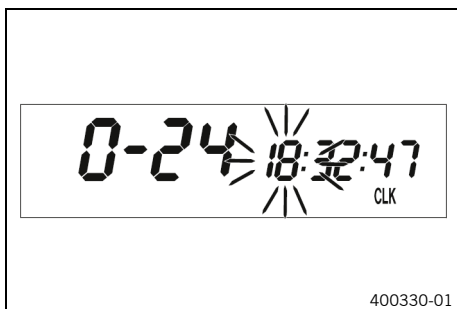

- Press button **+** briefly until indicator **CLK** appears in the bottom right of the display.
- Press button **+** for 2–3 seconds.
  - ✓ The hour display flashes.
- Adjust the hour display with the **button+** or **button-**.
- Wait 3–5 seconds.
  - ✓ The next segment of the display flashes and can be set.
- You can set the following segments in the same way as the hours by pressing the **button+** and **button-**.

**Note**

The seconds can only be set to zero. When a pulse is received from the wheel speed sensor, the settings are automatically saved and the setup menu is closed.

## 7.6 Viewing the lap time

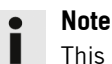

### Note

This function can only be opened if lap times have actually been timed.

Condition: Motorcycle is stationary

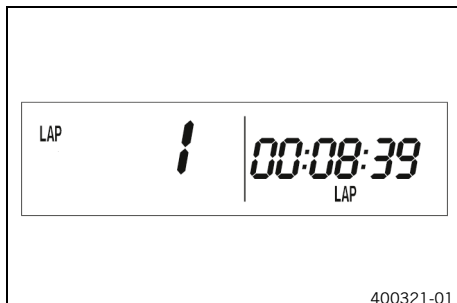

- Press button **+** briefly until indicator **LAP** appears in the bottom right of the display.
- Press button **+** briefly.
  - ✓ **LAP 1** appears on the left side of the display.
- You can use the **button-** to view laps 1-10.
- Press and hold the **button+** for 3-5 seconds.
  - ✓ The lap times are deleted.
- Press button **+** briefly.
  - ✓ Next display mode



### Note

When an impulse is received from the wheel speed sensor, the left side of the display changes back to the **SPEED** mode.

## 7.7 Display mode SPEED (speed)

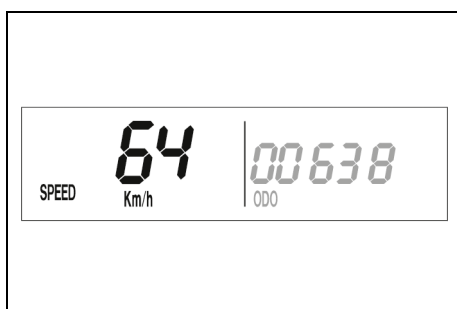

- Press button **+** briefly until indicator **SPEED** appears in the left of the display.

The current speed is displayed in the **SPEED** display mode.

The current speed can be displayed in **Km/h** or **Mph**.



### Note

Make the setting according to the country.

When an impulse comes from the front wheel, the left side of the display changes to the **SPEED** mode and the current speed is shown.

## 7.8 Display mode SPEED/H (operating hours)

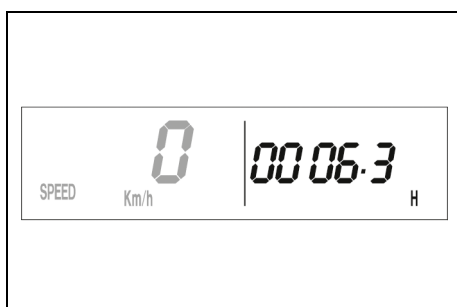

Condition: Motorcycle is stationary

- Press button **+** briefly until indicator **H** appears in the bottom right of the display.

In display mode **H**, the operating hours of the engine are displayed.

The operating hour counter stores the total traveling time.



### Note

The operating hour counter is necessary for ensuring that service work is carried out at the right intervals.

If the combination instrument is in **H** display mode when starting off, it automatically changes to the **ODO** display mode.

The **H** display mode is suppressed during the journey.

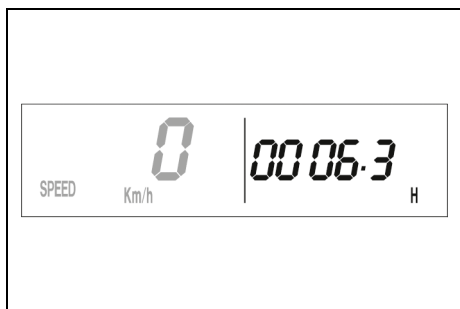

– Press button <b>+</b> for 2–3 seconds.	The display changes to the functions setup menu.
– Press button <b>+</b> briefly.	Next display mode
– Press button <b>–</b> for 2–3 seconds.	No function
– Press button <b>–</b> briefly.	No function

## 7.9 Setup menu

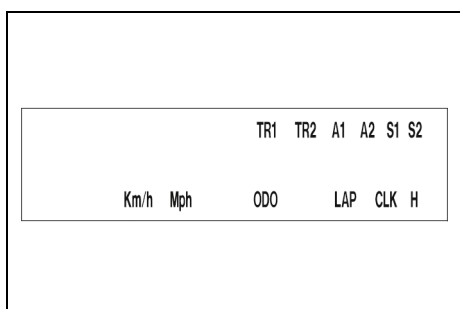

Condition: Motorcycle is stationary

- Press button **+** briefly until indicator **H** appears in the bottom right of the display.
- Press button **+** for 2–3 seconds.

The Setup menu displays the active functions.

**i Note**  
Repeatedly press the **button+** briefly until the desired function is reached.  
If no button is pressed for 20 seconds, the settings are automatically saved.

– Press button <b>+</b> briefly.	Activates the flashing display and changes to the next display
– Press button <b>+</b> for 2–3 seconds.	No function
– Press button <b>–</b> briefly.	Deactivates the flashing display and changes to the next display
– Press button <b>–</b> for 2–3 seconds.	No function
– Wait 3–5 seconds.	Changes to the next display without changes
– Wait 10–12 seconds.	Setup menu starts, stores the settings, and changes to <b>H</b> or <b>ODO</b> .

### 7.10 Adjusting the unit of measurement

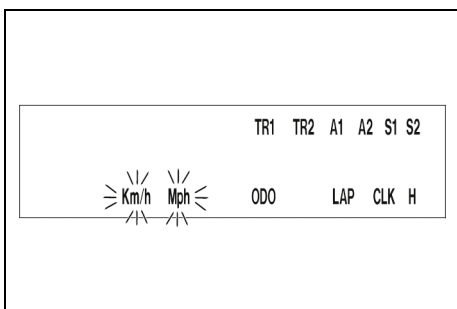

Condition: Motorcycle is stationary

- Press button **+** for 2–3 seconds.
- Press button **+** briefly until indicator **H** appears in the bottom right of the display.
- Press button **+** briefly until indicator **Km/h / Mph** flashes.

In measurement unit mode, you can change the unit of measurement.



**Note**

If no button is pressed for 5 seconds, the settings are automatically saved.

- Press button <b>+</b> briefly.	Starts selection, activates <b>Km/h</b> display
- Press button <b>+</b> for 2–3 seconds.	No function
- Press button <b>-</b> briefly.	Activates <b>Mph</b> display
- Press button <b>-</b> for 2–3 seconds.	No function
- Wait 3–5 seconds.	Changes to the next display, changes from selection to the Setup menu
- Wait 10–12 seconds.	Stores and closes the Setup menu.

### 7.11 Display mode SPEED/CLK (time)

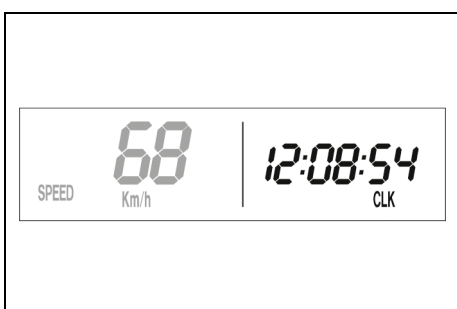

- Press button **+** briefly until indicator **CLK** appears in the bottom right of the display.

The time is shown in display mode **CLK**.

- Press button <b>+</b> for 2–3 seconds.	The display changes to the Setup menu of the clock.
- Press button <b>+</b> briefly.	Next display mode
- Press button <b>-</b> for 2–3 seconds.	No function

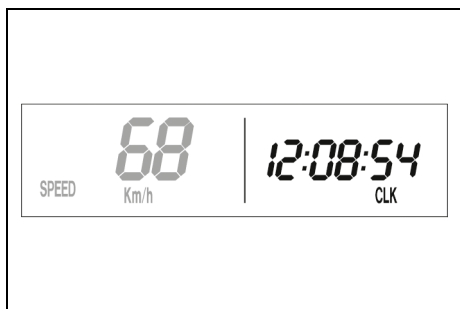





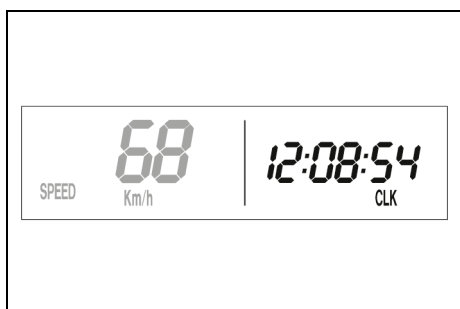

– Press button  briefly.	No function
---	-------------

## 7.12 Setting the clock





Condition: Motorcycle is stationary

- Press button  briefly until indicator **CLK** appears in the bottom right of the display.
- Press button  for 2–3 seconds.

– Press button  for 2–3 seconds.	Increases the value
– Press button  briefly.	Increases the value
– Press button  for 2–3 seconds.	Reduces the value
– Press button  briefly.	Reduces the value
– Wait 3–5 seconds.	Changes to the next value
– Wait 10–12 seconds.	Exit the Setup menu

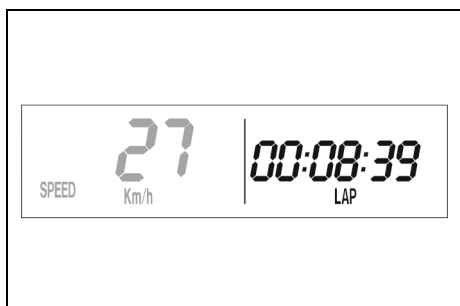
## 7.13 Display mode SPEED/LAP (lap time)



- Press button  briefly until indicator **LAP** appears in the bottom right of the display.

In the **LAP** display mode, up to 10 lap times can be timed with the stop watch.

### Note

If the lap time continues running after the button  is pressed, 9 memory locations are filled.

Lap 10 must be timed with the button .

- Press button <b>+</b> for 2-3 seconds.	The stop watch and the lap time are reset.
- Press button <b>+</b> briefly.	Next display mode
- Press button <b>-</b> for 2-3 seconds.	Stops the stop watch
- Press button <b>-</b> briefly.	Starts the stop watch or stops the current lap time measurement, stores it and the stop watch starts the next lap.

### 7.14 Viewing the lap time

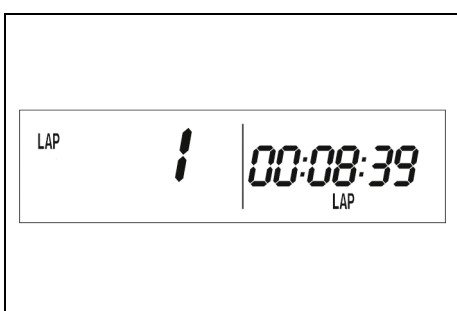

Condition: Motorcycle is stationary

- Press button **+** briefly until indicator **LAP** appears in the bottom right of the display.
- Press button **+** briefly.

- Press button <b>+</b> for 2-3 seconds.	The stop watch and the lap time are reset.
- Press button <b>+</b> briefly.	Select a lap from 1 - 10
- Press button <b>-</b> for 2-3 seconds.	No function
- Press button <b>-</b> briefly.	View the next lap time

### 7.15 Display mode SPEED/ODO (odometer)



- Press button **+** briefly until indicator **ODO** appears in the bottom right of the display.

The total traveled distance is shown in display mode **ODO**.

- Press button <b>+</b> for 2-3 seconds.	No function
- Press button <b>+</b> briefly.	Next display mode
- Press button <b>-</b> for 2-3 seconds.	No function



– Press button  briefly.	No function
---	-------------

## 7.16 Display mode SPEED/TR1 (trip master 1)

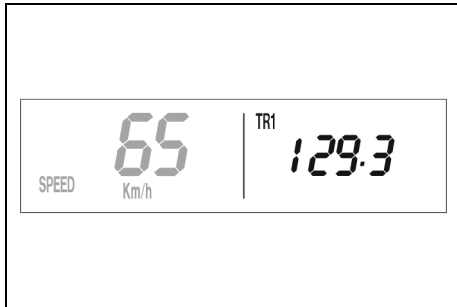





- Press button  briefly until indicator **TR1** appears in the top right of the display.

**TR1** (trip master 1) runs constantly and counts up to 999.9.

You can use it to measure trips or the distance between refueling stops.

**TR1** is coupled with **A1** (average speed 1) and **S1** (stop watch 1).

**Note**  
If 999.9 is exceeded, the values of **TR1**, **A1** and **S1** are automatically reset to 0.0.



– Press button  for 2–3 seconds.	Displays of <b>TR1</b> , <b>A1</b> and <b>S1</b> are reset to 0.0.
– Press button  briefly.	Next display mode
– Press button  for 2–3 seconds.	No function
– Press button  briefly.	No function

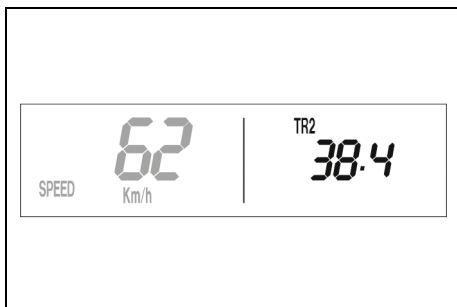

## 7.17 Display mode SPEED/TR2 (trip master 2)



- Press button  briefly until indicator **TR2** appears in the top right of the display.

**TR2** (trip master 2) runs constantly and counts up to 999.9.



– Press button  for 2–3 seconds.	Clears the values <b>TR2</b> and <b>A2</b>
– Press button  briefly.	Next display mode

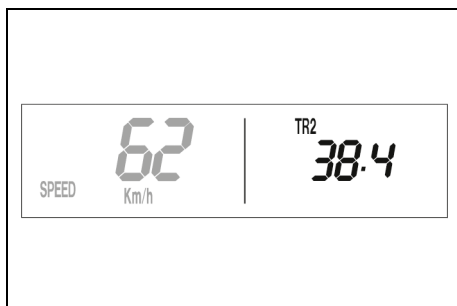

– Press button  for 2–3 seconds.	Reduces value <b>TR2</b>
– Press button  briefly.	Reduces value <b>TR2</b>

### 7.18 Adjusting TR2 (trip master 2)





Condition: Motorcycle is stationary





- Press button  briefly until indicator **TR2** appears in the top right of the display.
- Press the **button**  for 2–3 seconds until **TR2** flashes.

The displayed value can be set manually with the **button**  and **button** . This is a very practical function when riding using the road book.

**i Note**

The value of **TR2** can also be corrected manually during the journey with **button**  and **button** .

If 999.9 is exceeded, the value of **TR2** is automatically reset to 0.0.

– Press button  for 2–3 seconds.	Increases value <b>TR2</b>
– Press button  briefly.	Increases value <b>TR2</b>
– Press button  for 2–3 seconds.	Reduces value <b>TR2</b>
– Press button  briefly.	Reduces value <b>TR2</b>
– Wait 10–12 seconds.	Stores and closes the Setup menu.

## 7.19 Display mode SPEED/A1 (average speed 1)



- Press button **+** briefly until indicator **A1** appears in the top right of the display.

**A1** (average speed 1) shows the average speed calculated using **TR1** (trip master 1) and **S1** (stop watch 1).

The calculation of this value is activated by the first impulse of the wheel speed sensor and ends 3 seconds after the last impulse.

– Press button <b>+</b> for 2–3 seconds.	Displays of <b>TR1</b> , <b>A1</b> and <b>S1</b> are reset to 0.0.
– Press button <b>+</b> briefly.	Next display mode
– Press button <b>-</b> for 2–3 seconds.	No function
– Press button <b>-</b> briefly.	No function

## 7.20 Display mode SPEED/A2 (average speed 2)

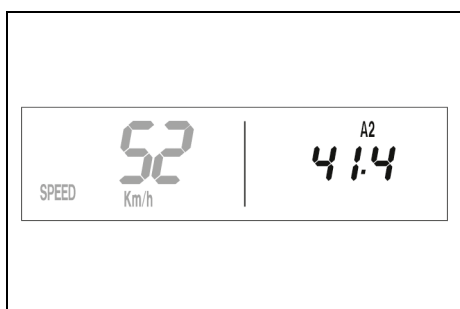

- Press button **+** briefly until indicator **A2** appears in the top right of the display.

**A2** (average speed 2) shows the average speed on the basis of the current speed if the stop watch **S2** (stop watch 2) is running.

**i Note**  
The displayed value can differ from the actual average speed if **S2** was not stopped after the ride.

– Press button <b>+</b> briefly.	Next display mode
– Press button <b>+</b> for 2–3 seconds.	No function
– Press button <b>-</b> for 2–3 seconds.	No function
– Press button <b>-</b> briefly.	No function

**7.21 Display mode SPEED/S1 (stop watch 1)**



- Press button **+** briefly until indicator **S1** appears in the top right of the display.

**S1** (Stop watch 1) shows the riding time based on **TR1** and continues running as soon as an impulse arrives from the wheel speed sensor.

The calculation of this value starts with the first impulse from the wheel speed sensor and ends 3 seconds after the last impulse.

– Press button <b>+</b> for 2–3 seconds.	Displays of <b>TR1</b> , <b>A1</b> and <b>S1</b> are reset to 0.0.
– Press button <b>+</b> briefly.	Next display mode
– Press button <b>-</b> for 2–3 seconds.	No function
– Press button <b>-</b> briefly.	No function

**7.22 Display mode SPEED/S2 (stop watch 2)**

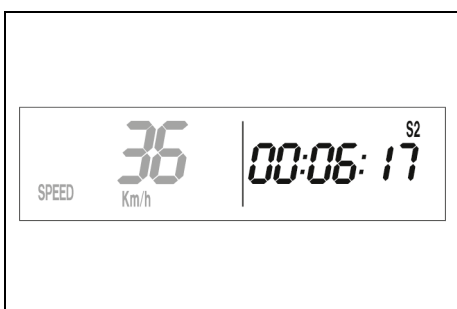

- Press button **+** briefly until indicator **S2** appears in the top right of the display.

**S2** (Stop watch 2) is a manual stop watch.

If **S2** is running in the background, the display **S2** flashes.

– Press button <b>+</b> for 2–3 seconds.	The displays of <b>S2</b> and <b>A2</b> are set to 0,0.
– Press button <b>+</b> briefly.	Next display mode
– Press button <b>-</b> for 2–3 seconds.	No function
– Press button <b>-</b> briefly.	Starts or stops <b>S2</b>

## 8.1 Notes on preparing for first use.



### DANGER

- Danger of accidents** A rider who is not fit to ride poses a danger to themselves and to others.
- Do not operate the vehicle if you are not fit to ride due to alcohol, drugs, or medication.
  - Do not operate the vehicle if you are physically or mentally incapable of doing so.



### WARNING

- Risk of injury** Missing or inadequate protective clothing increases the risk of injury.
- Wear appropriate protective clothing such as helmet, boots, gloves as well as pants and a jacket with protectors on all rides.
  - Always wear protective clothing that is in good condition and meets the legal regulations.



### WARNING

- Danger of accidents** Different tire profiles on the front and rear wheels can make it more difficult to control the vehicle.
- Make sure that only tires of the same tread type are mounted to the front and rear wheel.



### WARNING

- Danger of accidents** Not adapting the riding style constitutes a major risk.
- Adapt the vehicle speed to the road conditions and your riding ability.



### WARNING

- Danger of accidents** The vehicle is not designed to carry passengers.
- Do not ride with a passenger.



### WARNING

- Danger of accidents** The brake system fails in the event of overheating. If the brake pedal is not released, the brake pads grind continuously.
- Take your foot off the brake pedal when you are not braking.



### WARNING

- Danger of accidents** Total weight and axle loads influence the handling characteristic.
- Do not exceed the maximum permissible total weight or the axle loads.









### WARNING

- Risk of injury** People who act without authorization endanger themselves and others.
- Never leave the vehicle unattended while the engine is running.
  - Secure the vehicle against unauthorized access.



### Note

When using the motorcycle, remember that others may be disturbed by excessive noise.

- Ensure that the pre-sales inspection work has been carried out by an authorized KTM workshop.
  - ✓ The delivery certificate is transferred upon vehicle handover.
- Read the entire owner's manual before riding for the first time.
- Get to know the controls.
- Adjust the basic position of the clutch lever.  (p. 98)
- Adjust the free travel of the handbrake lever.  (p. 101)
- Adjust the basic position of the hand brake lever.
- Adjust the basic position of the brake pedal.   (p. 106)
- Adjust the basic position of the gear shift lever.   (p. 140)

- Get used to the handling characteristics of the motorcycle on suitable terrain before undertaking a more challenging ride.



**Note**

When off-road, it is recommended that you be accompanied by another person with another vehicle so that you can help each other.

- Also, ride as slowly as possible and in a standing position to get a better feel for the motorcycle.
- Do not make any off-road trips that exceed your ability and experience.
- Hold the handlebar firmly with both hands and keep your feet on the footpegs when riding.
- If luggage is carried, ensure it is fixed firmly as close as possible to the center of the vehicle and ensure even weight distribution between the front and rear wheels.



**Note**

Motorcycles react sensitively to any changes of weight distribution.

- The maximum permissible total weight and the maximum permissible axle loads must not be exceeded.

Maximum permissible total weight	335 kg
Maximum permissible front axle load	145 kg
Maximum permissible rear axle load	190 kg

- Check the spoke tension. 📖 (p. 117)



**Note**

The spoke tension must be checked after half an hour of operation.

- Run in the engine. 📖 (p. 41)



## 8.2 Running in the engine

- Do not exceed the specified engine speed and load during the running-in time.

Maximum engine speed	
During the first operating hour	7,000 rpm
Maximum engine power	
during the first 3 operating hours	≤ 75 %

- Avoid fully opening the throttle.



## 8.3 Starting performance of lithium-ion batteries at low temperatures

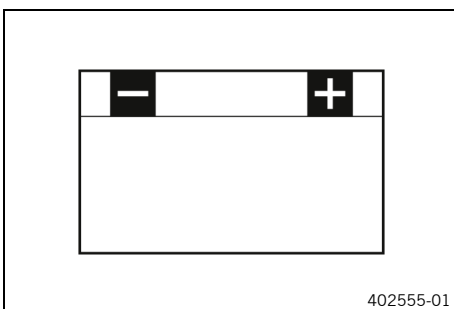

Lithium-ion batteries are far lighter than lead batteries, have a low self-discharge rate, and have more starting power at temperatures over 6 °C (43 °F).

Several attempts to start may be required. Press the start button for 5 seconds, and wait 15 seconds between attempts. At low temperatures, wait for 30 seconds. The pauses are necessary so that the heat created can be distributed through the lithium-ion battery without damaging the lithium-ion battery. The starting power increases as the battery warms up.

## 8 Preparing for use

Always make sure the lithium-ion battery is charged to that there is enough power to spare for starting at low temperatures.

After 6 unsuccessful starting attempts, do not try again, and check the vehicle for other faults instead.

### 8.4 Preparing the vehicle for difficult operating conditions

#### **i** Note

Use of the vehicle under difficult conditions, such as on sand or on wet and muddy surfaces, can result in significantly increased wear of components, such as the drive train, brake system, or suspension components. For this reason, it may be necessary to inspect or replace parts before the next scheduled service interval.

- Clean the air filter and air filter box. 🛠️ 📖 (p. 81)

Check the air filter approx. every 30 minutes.

- Check the connector for humidity and corrosion and to ensure it is firmly seated.
  - » If moisture, corrosion, or damage is found:
    - Clean and dry the socket connector, or change it if necessary.
- Riding on dry sand. 📖 (p. 42)
- Riding on wet sand. 📖 (p. 43)
- Rides on wet and muddy surfaces. 📖 (p. 43)
- Riding at high temperatures or slow speed. 📖 (p. 44)
- Riding at low temperatures and in snow. 📖 (p. 44)

### 8.5 Preparing the vehicle for rides on dry sand



- Mount the air filter dust protection.

Air filter dust protection cover (A46009620000)

#### **i** Note

Observe the fitting instructions for **KTM PowerParts**.



- Mount the air filter sand protection.

Air filter sand protection (A46006922000)

#### **i** Note

Observe the fitting instructions for **KTM PowerParts**.



- Clean the chain.

Chain cleaner  (p. 168)

- Mount the steel sprocket.
- Grease the chain.

Universal oil spray  (p. 165)

- Clean the radiator fins.
- Straighten the bent radiator fins carefully.



## 8.6 Preparing the vehicle for rides on wet sand



- Mount the air filter water protection.

Air filter water protection (A46006921000)



**Note**

Observe the fitting instructions for **KTM PowerParts**.



- Clean the chain.

Chain cleaner  (p. 168)

- Mount the steel sprocket.
- Grease the chain.

Universal oil spray  (p. 165)

- Clean the radiator fins.
- Straighten the bent radiator fins carefully.



## 8.7 Preparing for rides on wet and muddy surfaces



- Mount the air filter water protection.

Air filter water protection (A46006921000)



**Note**

Observe the fitting instructions for **KTM PowerParts**.

## 8 Preparing for use



- Mount the steel sprocket.
- Clean the motorcycle. 📖 (p. 146)
- Straighten the bent radiator fins carefully.

### 8.8 Preparing vehicle for rides at high temperature or slow speed



- Adjust the secondary transmission to the road conditions.



#### Note

The engine oil heats up quickly when the clutch is operated frequently due to an excessively high secondary ratio.



- Clean the chain.

Chain cleaner 📖 (p. 168)

- Clean the radiator fins.
- Straighten the bent radiator fins carefully.
- Check the coolant level. 📖 (p. 130)

### 8.9 Preparing the vehicle for low temperatures or snow



- Mount the air filter water protection.

Air filter water protection (A46006921000)



#### Note

Observe the fitting instructions for **KTM PowerParts**.

## 9.1 Checks and maintenance measures when preparing for use

### **i** Note

Before every trip, check the condition of the vehicle and ensure that it is safe to operate. The vehicle must be in perfect technical condition when it is being operated.

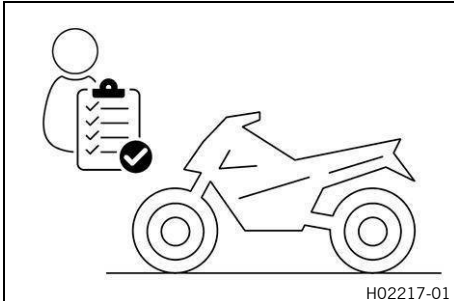

- Check the engine oil level. 📖 (p. 142)
- Check the electrical system.
- Check the brake fluid level for the front brake. 📖 (p. 102)
- Check the brake fluid level for the rear brake. 📖 (p. 107)
- Check that the brake pads of the front brake are secured. 📖 (p. 104)
- Check that the brake pads of the rear brake are secured. 📖 (p. 109)
- Check that the brake system is functioning properly.
- Check the coolant level. 📖 (p. 130)
- Check the chain for dirt. 📖 (p. 89)
- Check the chain, rear sprocket, engine sprocket, and chain guide. 📖 (p. 92)
- Check the chain tension. 📖 (p. 90)
- Check the tire condition. 📖 (p. 115)
- Check the tire pressure. 📖 (p. 116)

Condition: Offroad use

- Make sure that the rim locks are installed.
- Check the spoke tension. 📖 (p. 117)

The spoke tension must be checked regularly as incorrect spoke tension will severely impair riding safety.

- Clean the dust boots of the fork legs. 📖 (p. 66)
- Bleed the fork legs. 📖 (p. 65)
- Check the air filter.
- Check the settings of all controls and ensure that they can be operated smoothly.
- Check all screws, nuts, and hose clamps regularly for tightness.
- Check the fuel level.



## 9.2 Starting the vehicle



### **DANGER**

**Danger of poisoning** Exhaust gases are toxic and inhaling them may result in unconsciousness and death.

- Always ensure that there is sufficient ventilation when running the engine.
- Use suitable exhaust extraction when starting or running the engine in an enclosed space.



### **NOTE**

**Engine failure** Running a cold engine at high engine speeds negatively impacts the service life of the engine.

- Always warm up the engine at low engine speeds.

## 9 Riding instructions

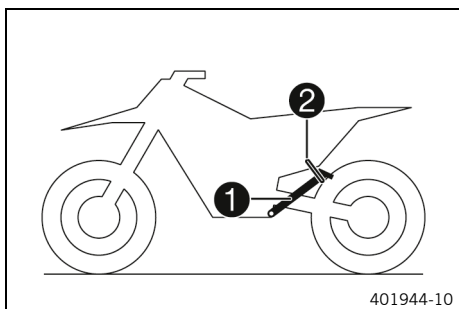

- Take the motorcycle off side stand **1** and secure the side stand with rubber band **2**.
- Shift the transmission into the neutral position.

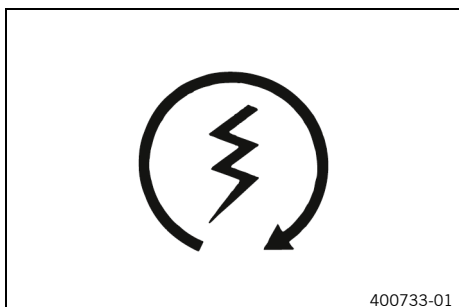

Condition: Ambient temperature: < 20 °C

- Press the cold start button in all the way to the stop.
- Press the electric starter.

Press the electric starter for a maximum of 5 seconds.

Wait for 30 seconds before a further attempt at starting.



### Note

At temperatures below 6 °C (43 °F), several attempts at starting may be necessary to warm-up the lithium-ion battery and thereby increase the starting power. The malfunction indicator light lights up during the starting process.

### 9.3 Activating traction control (All BR-models)



#### Note

If the combination switch is mounted, the vehicle's road permit, if any, expires.

The vehicle may only be operated in closed-off areas away from public road traffic if the combination switch is installed.

The traction control reduces excessive slip on the rear wheel in favor of more control and propulsion, particularly in wet conditions.

When traction control is switched off, the rear wheel may spin more during high acceleration and on surfaces with low grip.

Traction control can be switched on or off during the ride.

The setting most recently selected is activated again when restarting.



- Press the TC button **1** to switch traction control on or off.

Engine speed	≤ 4,000 rpm
--------------	-------------

- ✓ The **TC** LED lights up when the traction control is activated.

## 9.4 Starting off

**Note**

When you are riding, the side stand must be folded up and secured with the rubber band.

- Pull the clutch lever, shift into first gear, release the clutch lever slowly and at the same time carefully open the throttle.



## 9.5 Quickshifter (EXC-F BR / EXC-F SIX DAYS)

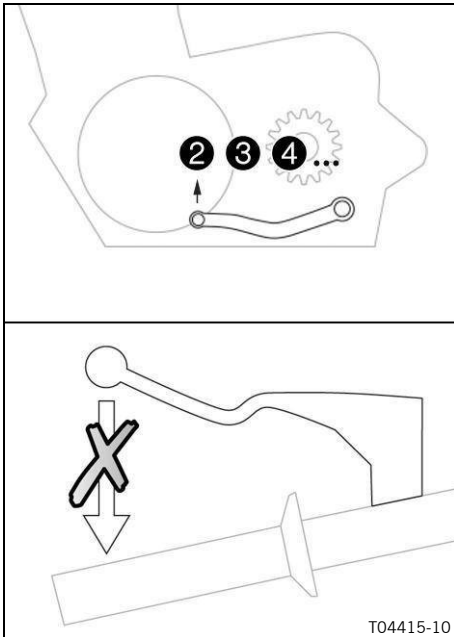

When the **quickshifter** is activated, you can shift up without actuating the clutch.

**Note**

The quickshifter is not activated when shifting up from first to second gear, and the clutch lever must be used when shifting up instead.

Even if the quickshifter is activated, you need to use the clutch lever to shift down.

Because there is no need to close the throttle grip, uninterrupted gear shifts are possible.

The quickshifter uses the shifter shaft position to check whether or not a shift should be initiated, and sends a corresponding signal to the engine control.

If the quickshifter is deactivated, the clutch needs to be actuated in the normal way for each shift.

## 9.6 Activate the quickshifter (EXC-F BR / EXC-F SIX DAYS)



- Press the QS button **1** to switch the quickshifter on or off.
  - ✓ The QS indicator lamp lights up when the quickshifter is activated.

**Note**

The quickshifter is not activated when shifting up from first to second gear, and the clutch lever must be used when shifting up instead.

Even if the quickshifter is activated, you need to use the clutch lever to shift down.



## 9.7 Shifting, riding



### WARNING

- Danger of accidents** If you downshift at high engine speed, the rear wheel blocks and the engine races.
- Do not downshift to a lower gear at high engine speeds.



### Note

- If unusual noises occur while riding, stop immediately, switch off the engine and contact an authorized KTM workshop.  
First gear is used for starting off or for steep inclines.

- Shift into a higher gear when conditions allow (incline, riding situation, etc.). To do so, release the throttle while simultaneously pulling the clutch lever, shift into the next gear, release the clutch lever and open the throttle.
- After reaching maximum speed by fully opening the throttle twist grip, turn the throttle back so that it is  $\frac{3}{4}$  open. This will reduce the speed slightly, but the fuel consumption will be considerably lower.
- Only open the throttle as much as the engine can handle. Abruptly opening the throttle increases fuel consumption.
- To shift down, apply the brakes and close the throttle at the same time.
- Pull the clutch lever and shift into a lower gear, release the clutch lever slowly, and either open the throttle or shift again.
- Switch off the engine if you are likely to be running at idle speed or stationary for a long time.  

$\geq 2$ min
--------------
- Avoid frequent and lengthy slipping of the clutch. This causes the engine oil, engine and cooling system to heat up.
- Ride at a low engine speed instead of at a high engine speed when riding the clutch.

## 9.8 Braking



### WARNING

- Danger of accidents** Braking with excessive force locks the wheels.
- Adapt your braking to the riding situation and the road conditions.



### WARNING

- Danger of accidents** A spongy pressure point on the front or rear brake reduces the brake action.
- Do not drive the vehicle if the brake system has a spongy pressure point.



### WARNING

- Danger of accidents** Moisture and dirt impair the brake system.
- Brake carefully several times to dry out and remove dirt from the brake pads and the brake discs.

- On sandy, wet, or slippery surfaces, use the rear brake.
- Always finish braking before you go into a bend. Shift into a lower gear that suits the speed.
- Use the brake action of the engine on long downhill stretches. To do so, shift back one or two gears, but do not overrev the engine. This means that significantly less braking is required and means the brake system does not overheat.

## 9.9 Stop, park



### WARNING

**Risk of injury** People who act without authorization endanger themselves and others.

- Never leave the vehicle unattended while the engine is running.
- Secure the vehicle against unauthorized access.



### NOTE

**Fire hazard** Hot vehicle components pose a fire hazard and explosion risk.

- Do not park the vehicle near materials which are highly flammable or explosive.
- Allow the vehicle to cool down before covering it.



### WARNING

**Danger of burns** Some vehicle components become hot when the vehicle is operated.

- Do not touch any parts such as the exhaust system, radiator, engine, damper, or brake system before the vehicle parts have cooled down.
- Allow the vehicle parts to cool down before performing any work on the vehicle.



### NOTE

**Material damage** The vehicle may be damaged if parked incorrectly.

Damage can occur if the vehicle rolls away or falls over.

The components for parking the vehicle are designed only for the weight of the vehicle.

- Park the vehicle on a firm and level surface.
- Make sure that nobody sits on the vehicle when it is parked on a stand.

- Brake the motorcycle.
- Shift the transmission into the neutral position.
- Press kill switch  when the engine is at idle speed until the engine stops.
- Park the motorcycle on firm ground.



## 9.10 Transportation



### NOTE

**Material damage** The vehicle may be damaged if parked incorrectly.

Damage can occur if the vehicle rolls away or falls over.

The components for parking the vehicle are designed only for the weight of the vehicle.

- Park the vehicle on a firm and level surface.
- Make sure that nobody sits on the vehicle when it is parked on a stand.



### NOTE

**Fire hazard** Hot vehicle components pose a fire hazard and explosion risk.

- Do not park the vehicle near materials which are highly flammable or explosive.
- Allow the vehicle to cool down before covering it.

## 9 Riding instructions

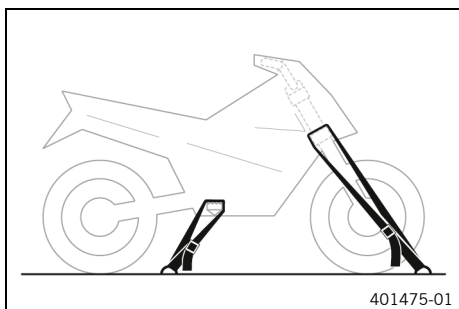

- Switch off the engine.
- Use tension belts or other suitable devices to secure the motorcycle against falling over or rolling away.

### 9.11 Refueling



#### DANGER

**Fire hazard** Fuel is highly flammable.

The fuel in the fuel tank expands when warm and can escape if overfilled.

- Do not refuel the vehicle in the vicinity of open flames, glowing, or smoldering objects.
- Make sure that nobody smokes in the vicinity of the vehicle during the refueling process.
- Switch off the engine for refueling.
- Make sure that no fuel is spilled; particularly not on hot parts of the vehicle.
- If any fuel is spilled, wipe it up immediately.
- Do not overfill the fuel tank.



#### WARNING

**Danger of poisoning** Fuel is harmful to health.

- Do not allow fuel to come into contact with skin, eyes, or clothing.
- Consult a doctor immediately if fuel has been ingested.
- Do not inhale fuel vapors.
- Rinse the affected area immediately with plenty of water in the event of contact with skin.
- Rinse eyes thoroughly with water and consult a doctor immediately if fuel comes into contact with eyes.
- If fuel spills on to your clothing, change the clothing.
- Store fuel properly in a suitable container and keep out of the reach of children.



#### NOTE

**Environmental hazard** Improper handling of fuel is dangerous to the environment.

- Do not allow fuel to enter the groundwater, the soil, or the sewage system.



#### NOTE

**Material damage** Inadequate fuel quality can lead to losses in performance and consequential damage.

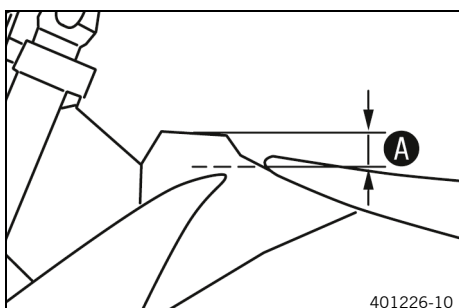

- Refuel only with clean fuel that meets the specified standards.



- Switch off the engine.
- Open the fuel tank cap.  (p. 23)
- Fill the fuel tank with fuel no higher than **A**.

Level **A**

35 mm

Total fuel tank capacity, approx.	
<b>(All except BR models)</b> Super unleaded (ROZ 95)  (p. 164)	8.5 l
<b>(All BR-models)</b> Super unleaded, type C (ROZ 95/RON 95/PON 91)  (p. 164)	































- Close the fuel tank cap.  (p. 23)



# 10 Service schedule



## 10.1 Service schedule

Any further work that results from the service work must be ordered separately and invoiced separately. Different service intervals may apply in your country, depending on the local operating conditions. Individual service intervals and scopes may change in the course of technical developments. The most up-to-date service schedule is available for authorized dealers for the electronic proof of service. Your authorized dealer will be happy to advise you.

	Every 24 months				
	Every 90 operating hours				
	Every 45 operating hours				
	Every 15 operating hours				
	After one operating hour				
Read out the fault memory using the diagnostics tool. 	○	●	●	●	●
Program the gear position sensor. 		●	●	●	
Check that the electrical equipment is functioning properly.	○	●	●	●	
Check and charge the 12 V battery. 		●	●	●	●
Check that the brake pads of the front brake are secured.  (p. 104)		●	●	●	●
Check that the brake pads of the rear brake are secured.  (p. 109)		●	●	●	●
Check the brake discs.  (p. 101)		●	●	●	●
Check the brake lines for damage and tightness.		●	●	●	●
Check the brake fluid level for the front brake.  (p. 102)		●	●		
Change the brake fluid for the front brake. 				●	●
Check the brake fluid level for the rear brake.  (p. 107)		●	●		
Change the brake fluid for the rear brake. 				●	●
Check/correct the fluid level of the hydraulic clutch.  (p. 97)			●		
Change the hydraulic clutch fluid.   (p. 98)				●	●
Check the free travel on the hand brake lever.  (p. 101)	○	●	●	●	●
Check the free travel of the brake pedal.  (p. 106)		●	●	●	●
Check the idle speed. 	○	●	●	●	●
Change the engine oil and the oil filter, clean the oil screens.   (p. 142)	○	●	●	●	●
Check all hoses (e.g. fuel, cooling, bleeder, drainage, etc.) and boots for cracking, leaks, and correct routing. 	○	●	●	●	●
Check the cables for damage and that there are no kinks in the routing. 		●	●	●	●
Check that the clutch cables are undamaged, routed without kinks, and set correctly.		●	●	●	
Check the frame.   (p. 95)		●	●	●	
Check the swingarm.   (p. 95)		●	●	●	
Check the swingarm bearing for play. 			●	●	
Check the heim joint on the shock absorber for play. 			●	●	
Check the tire condition.  (p. 115)		●	●	●	●
Check the tire pressure.  (p. 116)		●	●	●	●
Check the wheel bearing for play. 		●	●	●	
Check the hubs. 		●	●	●	

	Every 24 months			
	Every 90 operating hours			
	Every 45 operating hours			
	Every 15 operating hours			
	After one operating hour			
Check the rim run-out.	○	●	●	●
Check the spoke tension.  (p. 117)	○	●	●	●
Check the chain, rear sprocket, engine sprocket, and chain guide.  (p. 92)	○	●	●	●
Check the chain tension.  (p. 90)	○	●	●	●
Grease all moving parts (e.g. side stand, hand lever, chain, etc.) and check for smooth operation.	○	●	●	●
Check the valve clearance.	○	●	●	●
Change the fuel filter.	○	●	●	●
Check the clutch.	○	●	●	●
Clean the air filter and air filter box.   (p. 81)	○	●	●	●
<b>(All EU / AR / BR models)</b>	○	●	●	●
Check the funnel in the inlet sleeve in the air filter box.	○	●	●	●
<b>(XW-F)</b>	○	●	●	●
Check the inlet membrane.	○	●	●	●
Change the glass fiber filling of the muffler.   (p. 85)	○	●	●	●
Carry out fork service.	○	●	●	●
Service the shock absorber.	○	●	●	●
Check all screws, nuts, and hose clamps for a tight fit.	○	●	●	●
Change the fuel screen.   (p. 141)	○	●	●	●
Check the fuel pressure.	○	●	●	●
Check the frost protection and coolant level.  (p. 129)	○	●	●	●
Check the coolant level.  (p. 130)	○	●	●	●
Change the coolant.  (p. 133)	○	●	●	●
<b>(All special models / XW-F)</b>	○	●	●	●
Check that the radiator fan is functioning properly.	○	●	●	●
Check the steering head bearing play.  (p. 72)	○	●	●	●
Lubricate the steering head bearing.   (p. 74)	○	●	●	●
<b>(XW-F)</b>	○	●	●	●
Clean spark arrestor.   (p. 83)	○	●	●	●
Check the headlight setting.  (p. 125)	○	●	●	●
Perform engine service including removing and installing the engine. (Change the spark plug and spark plug connector. Change the piston. Check/measure the cylinder. Check the cylinder head. Change the valves, valve springs, valve spring retainers and valve spring seats. Check the camshaft and cam lever. Change the connecting rod, conrod bearing and crank pin. Check the transmission and shift mechanism. Check the oil pressure control valve. Change the suction pump. Check the force pump and lubrication system. Check the timing assembly. Change the timing chain. Change all engine bearings and all gaskets. Change the freewheel.)	○	●	●	●

# 10 Service schedule

	Every 24 months				
		Every 90 operating hours			
			Every 45 operating hours		
				Every 15 operating hours	
					After one operating hour
Final check: Check the vehicle is roadworthy and take a test ride. 	<input type="radio"/>	<input checked="" type="radio"/>	<input checked="" type="radio"/>	<input checked="" type="radio"/>	<input checked="" type="radio"/>
Read out the fault memory after the test ride using the diagnostics tool. 	<input type="radio"/>	<input checked="" type="radio"/>	<input checked="" type="radio"/>	<input checked="" type="radio"/>	<input checked="" type="radio"/>
Enter electronic proof of service. 	<input type="radio"/>	<input checked="" type="radio"/>	<input checked="" type="radio"/>	<input checked="" type="radio"/>	<input checked="" type="radio"/>

- One-time interval
- Periodic interval

## 11.1 Checking the basic chassis setting with the rider's weight



### Note

When adjusting the basic chassis setting, first adjust the shock absorber and then the fork.

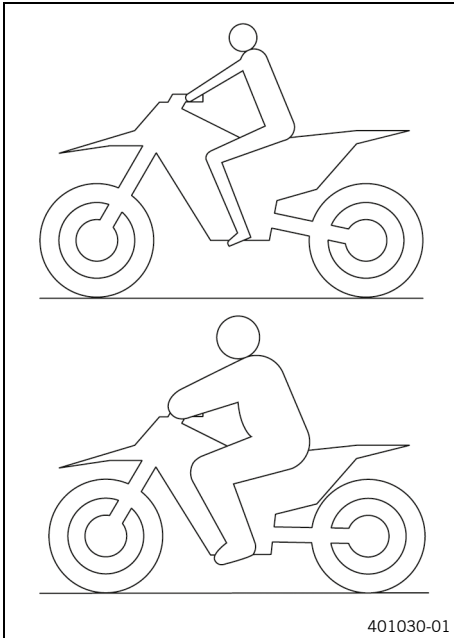

- For optimal motorcycle riding characteristics and to avoid damage to forks, shock absorbers, swingarm, and frame, the basic settings of the suspension components must match the rider's weight.
- As delivered, KTM offroad motorcycles are adjusted for an average rider's weight (with full protective clothing).

Standard rider weight	75 kg ... 85 kg
-----------------------	-----------------

- If the rider's weight is above or below this range, the basic setting of the suspension components must be adjusted accordingly.
- Small weight differences can be compensated for by adjusting the preload, but in the case of large weight differences, the springs must be replaced.



## 11.2 Compression damping of the shock absorber

The compression damping of the shock absorber is divided into two ranges: high-speed and low-speed.

High-speed and low-speed refer to the compression speed of the rear wheel suspension and not to the vehicle speed.

The high-speed compression has an effect, for example, when landing after a jump: the rear wheel suspension compresses quickly.

The low-speed compression has an effect, for example, when riding over long bumps: the rear wheel suspension compresses slowly.

These two ranges can be adjusted separately, although the transition between high-speed and low-speed is floating. As a result, changes in the high-speed range affect the compression damping in the low-speed range and vice versa.

## 11.3 Adjusting the low-speed compression damping of the shock absorber



### CAUTION

**Risk of injury** Parts of the shock absorber will move erratically if the shock absorber is detached incorrectly. The shock absorber is filled with highly compressed nitrogen.

- Please follow the description provided.



### Note

The effect of the low-speed compression adjustment can be seen in slow to normal compression of the shock absorber.

# 11 Tuning the chassis

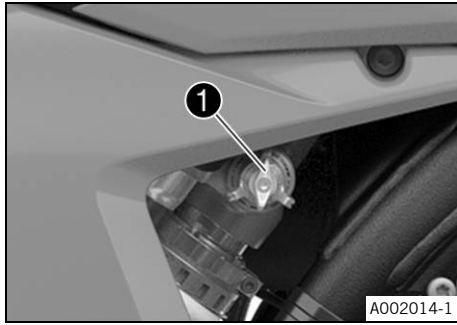

- Turn adjusting screw ① clockwise up to the last perceptible click.
- Turn counterclockwise by the number of clicks corresponding to the shock absorber type.

Comfort	18 clicks
Standard	15 clicks
Sport	12 clicks

**i Note**  
Turning clockwise increases damping; turning counterclockwise reduces damping during compression.

## 11.4 Adjusting the high-speed compression damping of the shock absorber



### CAUTION

**Risk of injury** Parts of the shock absorber will move erratically if the shock absorber is detached incorrectly. The shock absorber is filled with highly compressed nitrogen.

- Please follow the description provided.



### Note

The effect of the high-speed compression adjustment can be seen in the fast compression of the shock absorber.

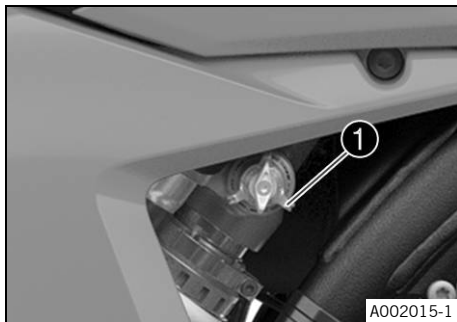

- Turn adjusting screw ① clockwise all the way.
- Turn counterclockwise by the number of turns corresponding to the shock absorber type.

Comfort	2.5 turns
Standard	2 turns
Sport	1.5 turns

**i Note**  
Turning clockwise increases damping; turning counterclockwise reduces damping during compression.

## 11.5 Adjusting the rebound damping of the shock absorber



### CAUTION

**Risk of injury** Parts of the shock absorber will move erratically if the shock absorber is detached incorrectly. The shock absorber is filled with highly compressed nitrogen.

- Please follow the description provided.

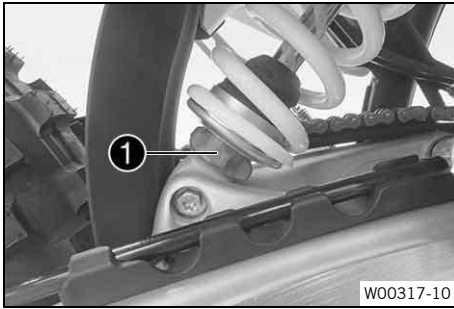

- Turn adjusting screw **1** clockwise up to the last perceptible click.
- Turn counterclockwise by the number of clicks corresponding to the shock absorber type.

Comfort	18 clicks
Standard	15 clicks
Sport	12 clicks

**i Note**  
Turning clockwise increases damping; turning anticlockwise reduces damping on rebound.



## 11.6 Measuring the dimension of the unloaded rear wheel

### Preparatory work

- Raise the motorcycle with a lift stand. (p. 65)

### Control process

- Position the sag gage in the rear axle and measure the distance to marking **SAG** on the rear fender.

Sag scale (00029090200)

- Note the value as dimension **A**.

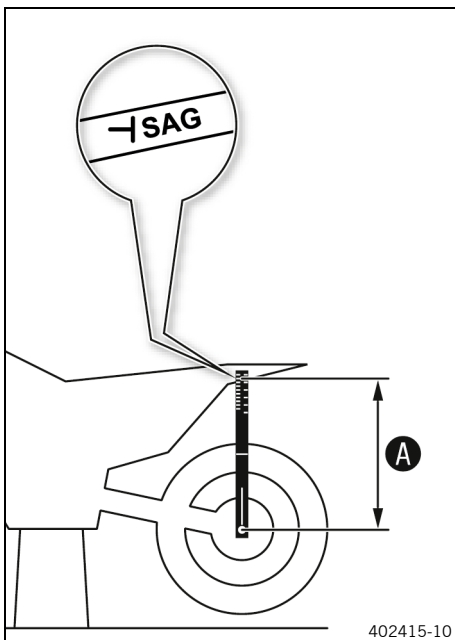

### Reworking

- Remove the motorcycle from the lift stand. (p. 65)



## 11.7 Checking the static sag of the shock absorber

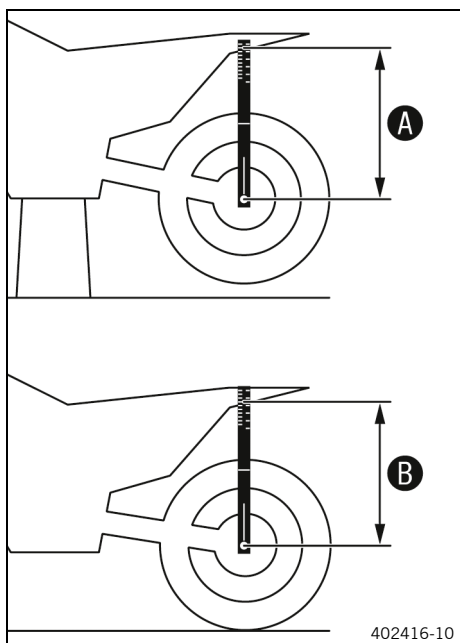

- Measure the dimension of the unloaded rear wheel. (p. 57)
- Hold the motorcycle upright with aid of an assistant.
- Measure the distance again between the rear axle and marking **SAG** on the rear fender using the sag gage.
- Note the value as dimension **B**.

### Note

The static sag is the difference between measurements **A** and **B**.

- Check the static sag.

Static sag	38 mm
------------	-------

- » If the static sag is more or less than the specified value:
  - Adjust the preload for the shock absorber. (p. 59)

## 11.8 Checking the rider sag of the shock absorber

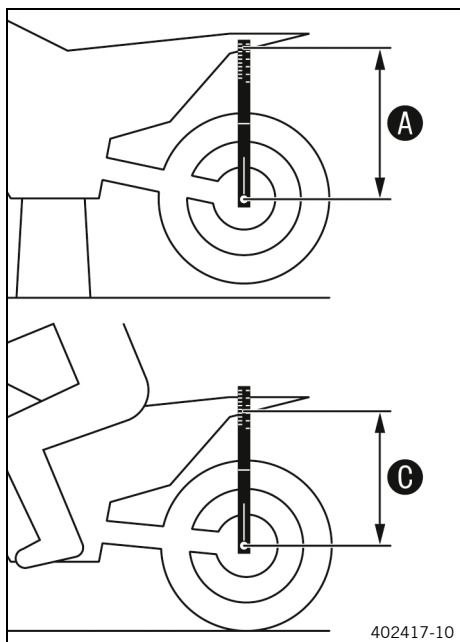

- Measure the dimension of the unloaded rear wheel. (p. 57)
- With another person holding the motorcycle, the rider, wearing full protective clothing, sits on the seat in a normal seating position (feet on footpegs) and bounces up and down a few times.
  - ✓ The rear wheel suspension levels out.
- Another person again measures the distance between the rear axle and marking **SAG** on the rear fender using the sag gage.
- Note the value as dimension **C**.

### Note

The rider sag is the difference between measurements **A** and **C**.

- Check the rider sag.

Rider sag	110 mm
-----------	--------

- » If the rider sag differs from the specified measurement:
  - Adjust the rider sag. (p. 60)

## 11.9 Adjusting the preload for the shock absorber



### CAUTION

**Risk of injury** Parts of the shock absorber will move erratically if the shock absorber is detached incorrectly. The shock absorber is filled with highly compressed nitrogen.







- Please follow the description provided.



### Note

Before changing the preload, make a note of the present setting, e.g., by measuring the spring length.

### Preparatory work

- Raise the motorcycle with a lift stand.  (p. 65)
- Remove the seat.  (p. 78)
- Remove the frame protector.  (p. 67)
- Remove the muffler.  (p. 82)
- Remove the shock absorber.   (p. 75)
- After removing the shock absorber, clean it thoroughly.

### Adjustment procedure

- Loosen screw **1**.
- Turn adjusting ring **2** until the spring is no longer under tension.

Hook wrench (90129051000)
---------------------------



### Note

If the spring cannot be fully released, the spring must be removed to accurately measure the spring length.

- Measure the total spring length while the spring is not under tension.
- Tension the spring by turning adjusting ring **2** to the specified degree **A**.

Preload	7 mm
---------	------



### Note

Depending on the static sag and/or the riding sag, it may be necessary to increase or decrease the spring preload.

- Tighten screw **1**.



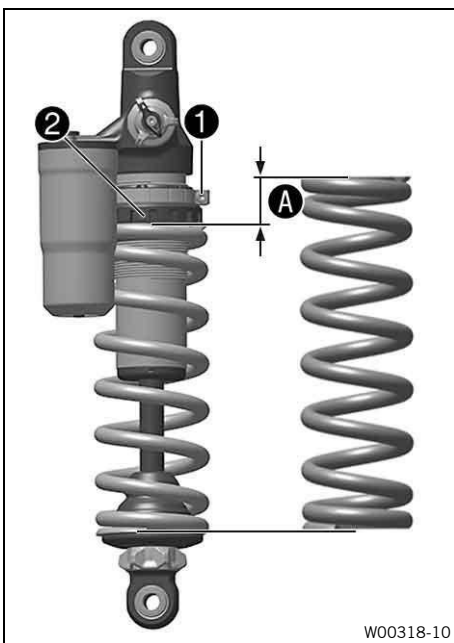

Screw, shock absorber adjusting ring
--------------------------------------



M5	5 Nm
----	------



W00318-10







### Reworking

- Install the shock absorber.   (p. 76)
- Install the muffler.  (p. 83)
- Install the frame protector.  (p. 67)

- Mount the seat.  (p. 78)
- Remove the motorcycle from the lift stand.  (p. 65)

## 11.10 Adjusting the rider sag

### Preparatory work

- Raise the motorcycle with a lift stand.  (p. 65)
- Remove the seat.  (p. 78)
- Remove the frame protector.  (p. 67)
- Remove the muffler.  (p. 82)
- Remove the shock absorber.   (p. 75)
- After removing the shock absorber, clean it thoroughly.

### Adjustment procedure

- Select and mount a suitable spring.

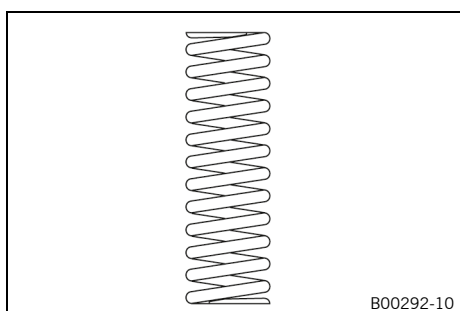









Weight of rider: 65 kg ... 75 kg	69 N/mm
Weight of rider: 75 kg ... 85 kg	72 N/mm
Weight of rider: 85 kg ... 95 kg	75 N/mm

#### Note

The spring rate is shown on the outside of the spring. Smaller weight differences can be compensated by changing the spring preload.

### Reworking

- Install the shock absorber.   (p. 76)
- Install the muffler.  (p. 83)
- Install the frame protector.  (p. 67)
- Mount the seat.  (p. 78)
- Remove the motorcycle from the lift stand.  (p. 65)
- Check the static sag of the shock absorber.  (p. 58)
- Check the rider sag of the shock absorber.  (p. 58)
- Adjust the rebound damping of the shock absorber.  (p. 56)

## 11.11 Checking the basic setting of the fork

#### Note

For various reasons, no exact rider sag can be determined for the fork.

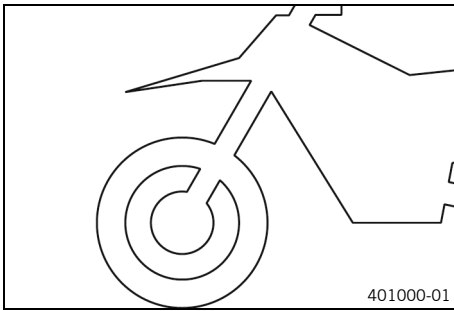

- As with the shock absorber, smaller differences in the rider's weight can be compensated by the spring preload.
- However, if the fork frequently bottoms out (hard end stop on compression), harder springs must be fitted to avoid damage to the fork and frame.
- If the fork feels unusually hard after extended periods of operation, the fork legs need to be bled.



## 11.12 Adjusting the compression damping of the fork



### Note

The hydraulic compression damping determines the fork suspension behavior.

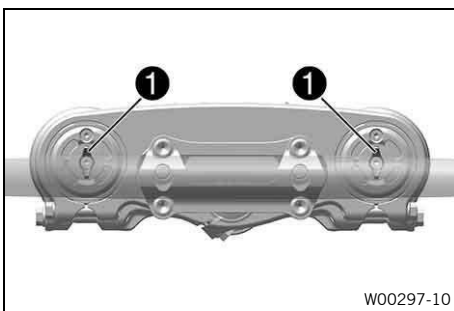

- Turn white adjuster ① clockwise as far as it will go.



### Note

Adjuster ① **COMP** is located at the top end of the fork legs.

- Turn clockwise by the number of clicks corresponding to the fork type.

Compression damping	
Comfort	17 clicks
Standard	15 clicks
Sport	7 clicks



### Note

Turning clockwise increases damping; turning counter-clockwise reduces damping during compression.



## 11.13 Adjusting the rebound damping of the fork



### Note

The hydraulic rebound damping determines the fork suspension behavior.

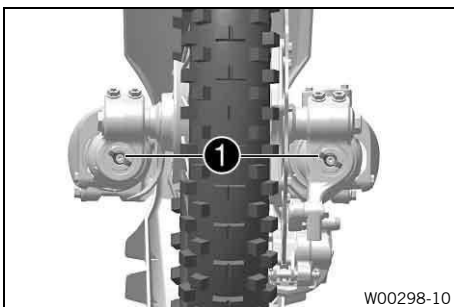

- Turn red adjuster ① clockwise as far as it will go.



### Note

Adjuster ① **REB** is located at the top end of the fork legs.

- Turn clockwise by the number of clicks corresponding to the fork type.

# 11 Tuning the chassis

Rebound damping	
Comfort	19 clicks
Standard	17 clicks
Sport	9 clicks



### Note

Turning clockwise increases damping; turning anticlockwise reduces damping on rebound.

## 11.14 Handlebar position

(All except SIX DAYS)

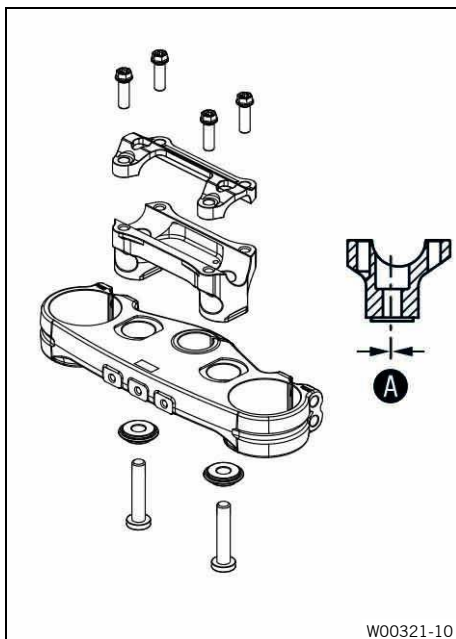

The holes on the handlebar support are placed at a distance of **A** from the center.

Hole distance <b>A</b>	3.5 mm
------------------------	--------

The handlebar support can be mounted in two different positions.

(EXC-F SIX DAYS)

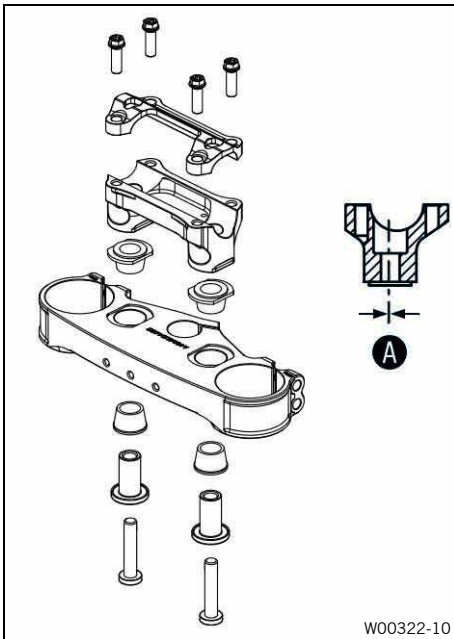

The holes on the handlebar support are placed at a distance of **A** from the center.

Hole distance <b>A</b>	3.5 mm
------------------------	--------

The handlebar support can be mounted in two different positions.

## 11.15 Adjusting the handlebar position



### WARNING

**Danger of accidents** A repaired handlebar poses a safety risk.

If the handlebar is bent or straightened, the material becomes fatigued. The handlebar may break as a result.

- Change the handlebar if the handlebar is damaged or bent.

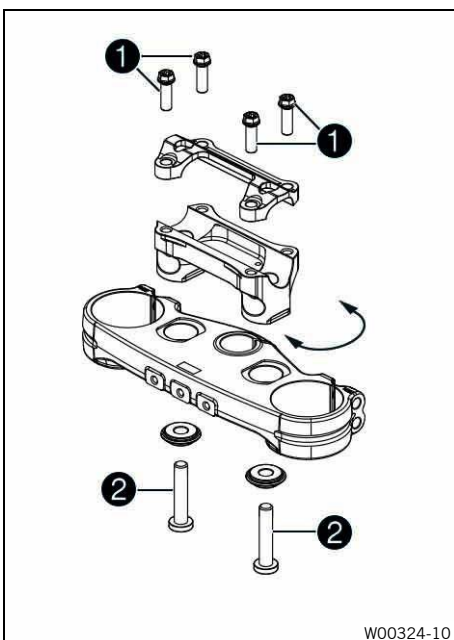

(All except **SIX DAYS**)

- Remove **1** screws.

Protect the components against damage by covering them.

- Take off the handlebar clamp.
- Remove the handlebar and lay it to one side.

Do not kink the cables or lines.

- Remove **2** screws.
- Take off the handlebar support.
- Place the handlebar mount in the required position.

Position the handlebar support so that it is even.

- Mount and tighten screws **2**.

Screw, handlebar mount

M10

40 Nm

**Loctite® 243**

- Position the handlebar.

Make sure the cables and wiring are positioned correctly.

- Position the handlebar clamp.

# 11 Tuning the chassis

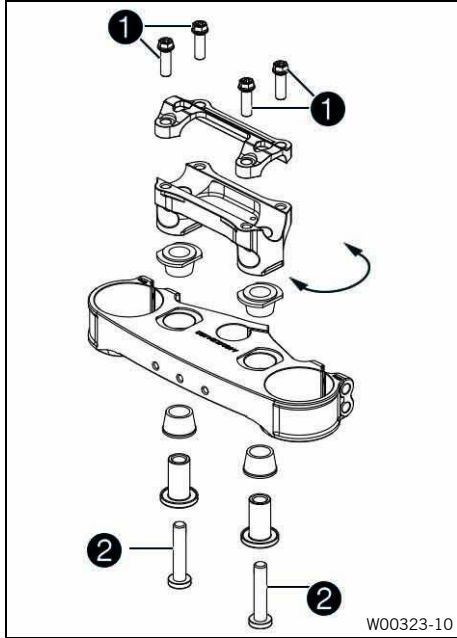

- Mount screws **1** and tighten evenly.

Handlebar clamp screw	
M8	20 Nm

Make sure the installed gap widths are even.

## (EXC-F SIX DAYS)

- Remove **1** screws.

Protect the components against damage by covering them.

- Take off the handlebar clamp.
- Remove the handlebar and lay it to one side.

Do not kink the cables or lines.

- Remove **2** screws.
- Take off the handlebar support.
- Place the handlebar mount in the required position.

Position the handlebar support so that it is even.

- Mount and tighten screws **2**.

Screw, handlebar mount	
M10	40 Nm
<b>Loctite® 243</b>	

- Position the handlebar.

Make sure the cables and wiring are positioned correctly.

- Position the handlebar clamp.
- Mount screws **1** and tighten evenly.

Handlebar clamp screw	
M8	20 Nm

Make sure the installed gap widths are even.

### 12.1 Raising the motorcycle with a lift stand

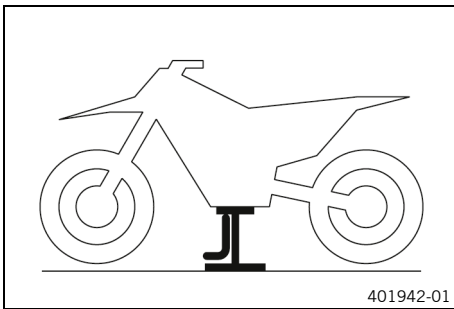

#### NOTE

**Material damage** The vehicle may be damaged if parked incorrectly.

Damage can occur if the vehicle rolls away or falls over. The components for parking the vehicle are designed only for the weight of the vehicle.

- Park the vehicle on a firm and level surface.
- Make sure that nobody sits on the vehicle when it is parked on a stand.

- Raise the motorcycle at the frame underneath the engine.

Lift stand (78129955100)

- ✓ Neither wheel is in contact with the ground.
- Secure the motorcycle against falling over.



### 12.2 Removing the motorcycle from the lift stand



#### NOTE

**Material damage** The vehicle may be damaged if parked incorrectly.

Damage can occur if the vehicle rolls away or falls over.

The components for parking the vehicle are designed only for the weight of the vehicle.

- Park the vehicle on a firm and level surface.
- Make sure that nobody sits on the vehicle when it is parked on a stand.

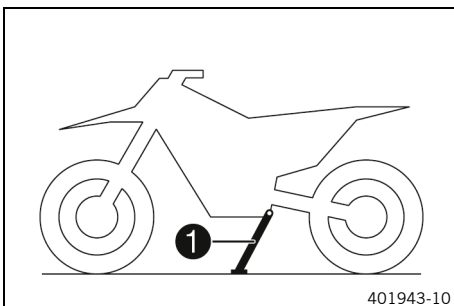

- Remove the motorcycle from the lift stand.
- Remove the lift stand.
- To park the motorcycle, press side stand ① to the ground with your foot and lean the motorcycle on it.



#### Note

When you are riding, the side stand must be folded up and secured with the rubber band.



### 12.3 Bleeding the fork legs

#### Preparatory work

- Raise the motorcycle with a lift stand.  (p. 65)

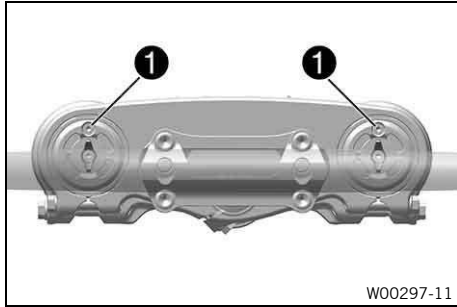

### Operating procedure

- Loosen bleeder screw ①.
- ✓ Any excess pressure escapes from the inner fork.
- Tighten the bleeder screw.

### Reworking

- Remove the motorcycle from the lift stand. 📖 (p. 65)

## 12.4 Cleaning the dust boots of the fork legs

### Preparatory work

- Raise the motorcycle with a lift stand. 📖 (p. 65)
- Remove the fork protector. 📖 (p. 67)



### Cleaning process

- Push dust boot ① downward on both fork legs.



#### Note

The dust boots should remove dust and coarse dirt particles from the inner fork tubes. Over time, dirt can accumulate behind the dust boots. If this dirt is not removed, the oil seals behind can start to leak.



#### WARNING

**Danger of accidents** Oil, grease or wax on the brake discs reduces the brake action.

- Always keep the brake discs free of oil, fat and wax.
- Clean the brake discs with brake cleaner when necessary.

- Clean and oil the dust boots and the inner fork tube of both fork legs.

Universal oil spray 📖 (p. 165)

- Press the dust boots back into their installation position.
- Remove excess oil.

### Reworking

- Install the fork protector. 📖 (p. 67)
- Remove the motorcycle from the lift stand. 📖 (p. 65)

## 12.5 Removing the fork protector

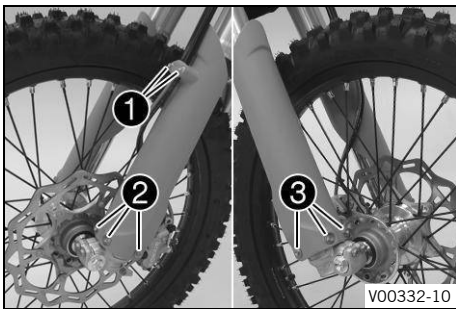

- Remove screw **1** and take off the clamp.
- Remove screws **2** on the left fork leg and take off the left fork protector.
- Remove screws **3** on the right fork leg and take off the right fork protector.

## 12.6 Installing the fork protector

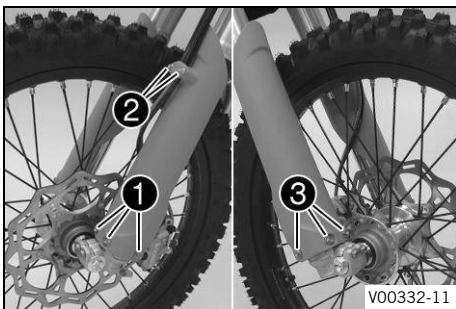

- Position the fork protector on the left fork leg. Mount and tighten screws **1**.

Remaining screws on chassis	
M6	10 Nm

- Position the brake line, the wiring harness, and the clamp. Mount and tighten screws **2**.
- Position the fork protector on the right fork leg. Mount and tighten screws **3**.

Remaining screws on chassis	
M6	10 Nm

## 12.7 Removing the frame protector

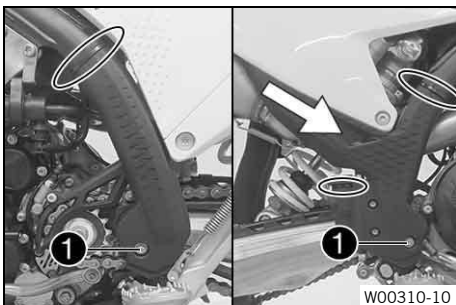

- Remove the cable ties.
- Remove screws **1** and bushings.
- Take off the left frame protector.
- Push the right frame protector to the front and take off at the bottom.

## 12.8 Installing the frame protector

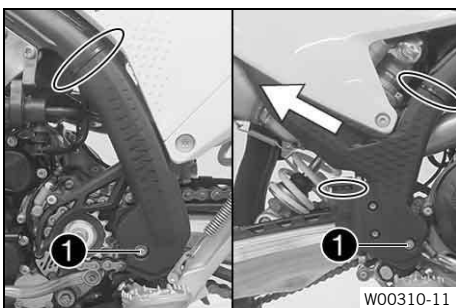

- Position the left frame protector.
- Insert the right frame protector from below and push it to the rear.
- Mount screw **1** and bushing and tighten.



Screw, frame protector	
M5	3 Nm

- Secure the frame protector with cable ties.

Turn the head of the cable tie so far back that it does not touch any other components.

## 12.9 Removing the fork legs

### Preparatory work

- Raise the motorcycle with a lift stand.  (p. 65)
- Remove the front wheel.   (p. 112)

### Removal process

- Remove screw **1** and take off the clamp.
- Remove the cable ties.
- Remove screws **2** and take off the brake caliper.
- Allow the brake caliper and the brake line to hang loosely to the side.

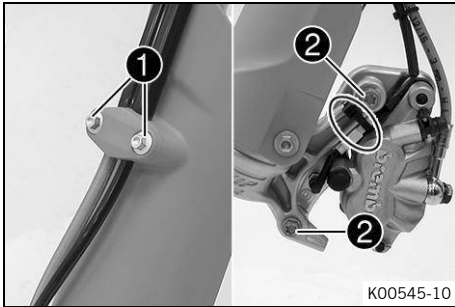

- Loosen screws **3**. Remove the left fork leg.
- Loosen screws **4**. Remove the right fork leg.

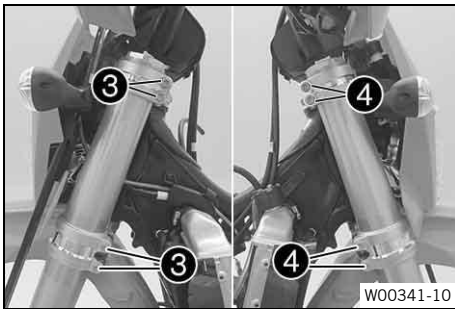

## 12.10 Installing the fork legs

### Installation procedure

- Position the fork legs.
- ✓ Bleeder screws **1** are positioned toward the front.



#### Note

Grooves are milled into the side of the upper end of the fork legs. The second milled groove (from the top) must be flush with the upper edge of the upper triple clamp. The pressure and rebound damping is located in the left and right fork leg.

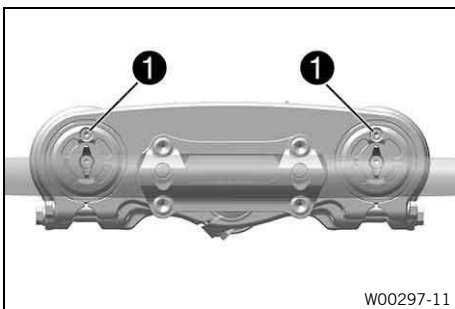

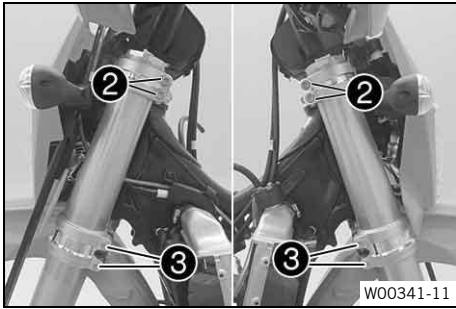

- Tighten screws **2**.

Screw, top triple clamp	
<b>(All except SIX DAYS)</b> M8	20 Nm
Screw, top triple clamp	
<b>(EXC-F SIX DAYS)</b> M8	17 Nm

- Tighten screws **3**.

Screw, bottom triple clamp	
<b>(All except SIX DAYS)</b> M8	15 Nm
Screw, bottom triple clamp	
<b>(EXC-F SIX DAYS)</b> M8	12 Nm

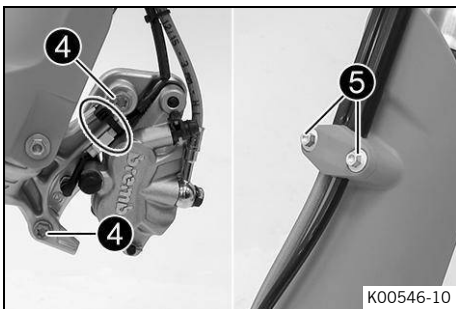

- Position the brake caliper, and mount and tighten screws **4**.

Screw, front brake caliper	
M8	25 Nm
<b>Loctite® 243</b>	

- Mount cable ties.
- Position the brake line, the wiring harness, and the clamp. Mount and tighten screws **5**.

### Reworking

- Install the front wheel. (p. 113)

## 12.11 Removing the lower triple clamp

### Preparatory work

- Raise the motorcycle with a lift stand. (p. 65)
- Remove the front wheel. (p. 112)
- Remove the fork legs. (p. 68)
- Remove the headlight mask with the headlight. (p. 123)
- Remove the front top fender. (p. 74)
- Remove the seat. (p. 78)
- Remove the fuel tank. (p. 85)
- Remove the handlebar pad.

## 12 Service work on the chassis

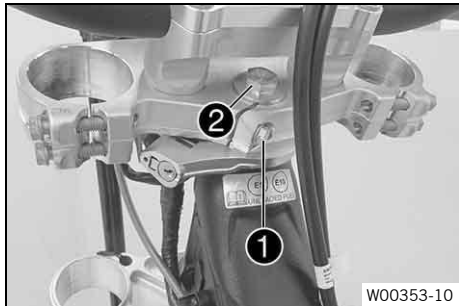

### Removal process

- Loosen screw ❶.
- Remove screw ❷.
- Take off the upper triple clamp with the handlebar and hang them to the side.

Protect the components against damage by covering them.

Do not kink the cables or lines.



- Remove protective ring ❸.
- Take off the lower triple clamp with the steering stem.
- Remove the upper steering head bearing.

### 12.12 Installing the lower triple clamp

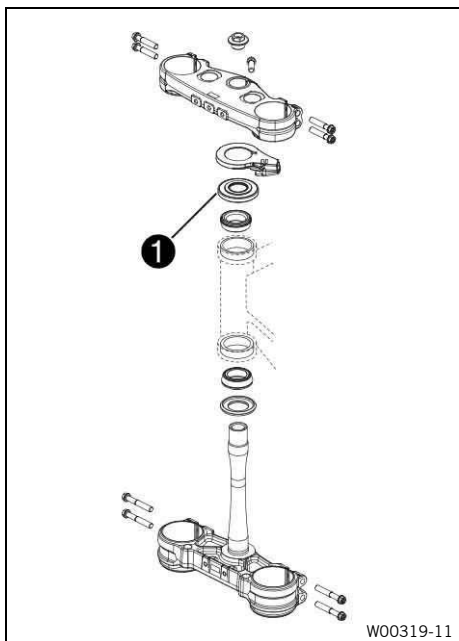

### Installation procedure

- Clean the bearing and sealing elements, check for damage, and grease.

High viscosity grease (p. 166)

- Insert the lower triple clamp with the steering stem. Mount the upper steering head bearing.
- Push on protective ring ❶.

(All EU models / AR)

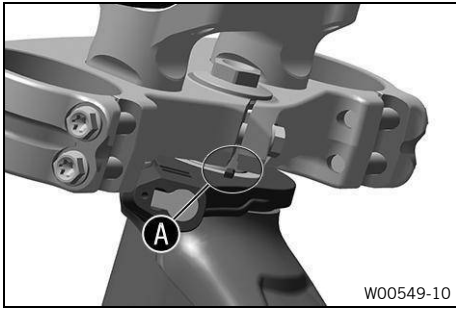

- Make sure the steering lock in area **A** is positioned correctly.
- ✓ The catch on the steering lock engages in the notch on the triple clamp.

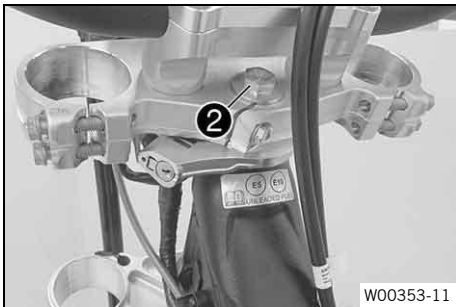

- Position the upper triple clamp and handlebar.
- Mount screw **2**, but do not tighten yet.

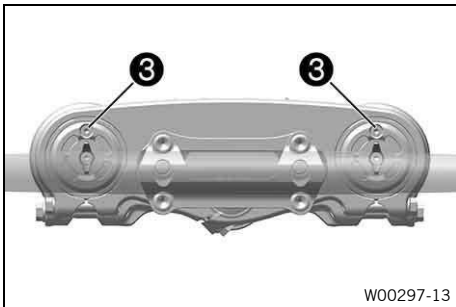

- Position the fork legs.
- ✓ Bleeder screws **3** are positioned toward the front.

**i Note**  
Grooves are milled into the side of the upper end of the fork legs. The second milled groove (from the top) must be flush with the upper edge of the upper triple clamp. The pressure and rebound damping is located in the left and right fork leg.

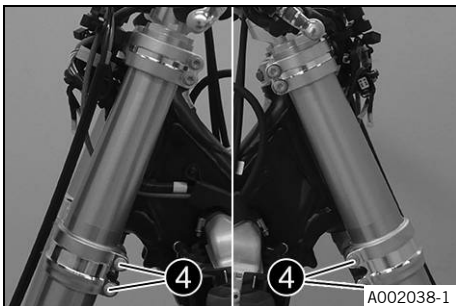

- Tighten screws **4**.

Screw, bottom triple clamp	
<b>(All except SIX DAYS)</b> M8	15 Nm
Screw, bottom triple clamp	
<b>(EXC-F SIX DAYS)</b> M8	12 Nm

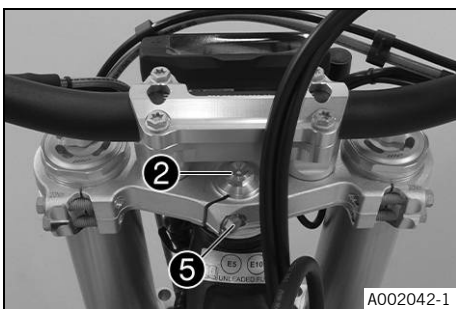

- Tighten screw **2**.

Screw, top steering head	
M20×1.5	12 Nm

- Tighten screw **5**.

Screw, upper steering stem	
M8	20 Nm
<b>Loctite® 243</b>	

## 12 Service work on the chassis

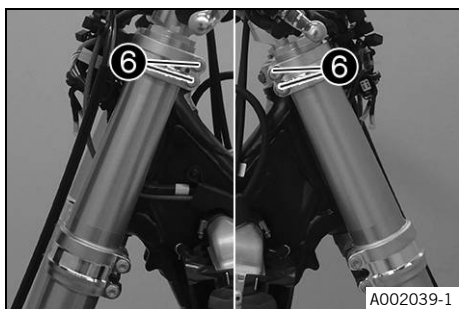

- Tighten screws ⑥.

Screw, top triple clamp	
(All except SIX DAYS) M8	20 Nm
Screw, top triple clamp	
(EXC-F SIX DAYS) M8	17 Nm

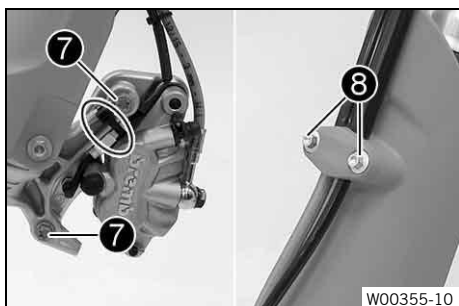

- Position the brake caliper, and mount and tighten screws ⑦.

Screw, front brake caliper	
M8	25 Nm
<b>Loctite® 243</b>	

- Mount cable ties.
- Position the brake line, the wiring harness, and the clamp. Mount and tighten screws ⑧.

### Reworking

- Mount the handlebar pad.
- Install the front top fender. 📖 (p. 75)
- Install the front wheel. 🛠️ 📖 (p. 113)
- Install the headlight mask with the headlight. 📖 (p. 124)
- Check the wiring harness, cables, and brake and clutch lines for freedom of movement and correct routing.
- Check the steering head bearing play. 📖 (p. 72)
- Remove the motorcycle from the lift stand. 📖 (p. 65)
- Check the headlight setting. 📖 (p. 125)
- Install the fuel tank. 🛠️ 📖 (p. 87)
- Mount the seat. 📖 (p. 78)

### 12.13 Checking the steering head bearing play



#### WARNING

**Danger of accidents** Incorrect steering head bearing play can impair the handling characteristic and damage components.

- Correct incorrect steering head bearing play immediately.



#### Note

If the vehicle is operated for a lengthy period with play in the steering head bearing, the bearings and the bearing seats in the frame can become damaged.

#### Preparatory work

- Raise the motorcycle with a lift stand. 📖 (p. 65)

## Control process

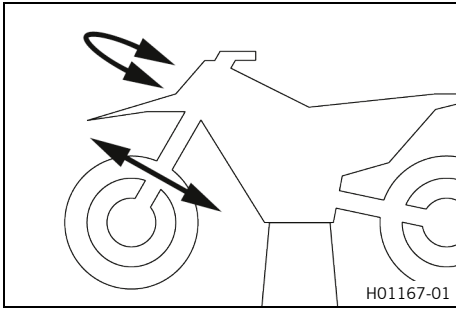

- Move the handlebar to the straight-ahead position. Move the fork legs to and fro in the direction of travel.

Play should not be detectable on the steering head bearing.

- » If there is detectable play:
  - Adjust the steering head bearing play. (p. 73)

- Move the handlebar back and forth over the entire steering range.

It must be possible to move the handlebar easily over the entire steering range. There should be no detectable detent positions.

- » If detent positions are detected:
  - Adjust the steering head bearing play. (p. 73)
  - Check the steering head bearing and replace if necessary.

## Reworking

- Remove the motorcycle from the lift stand. (p. 65)



## 12.14 Adjusting the steering head bearing play

### Preparatory work

- Raise the motorcycle with a lift stand. (p. 65)

### Adjustment procedure

- Loosen screws **1** and **2**.
- Loosen and retighten screw **3**.

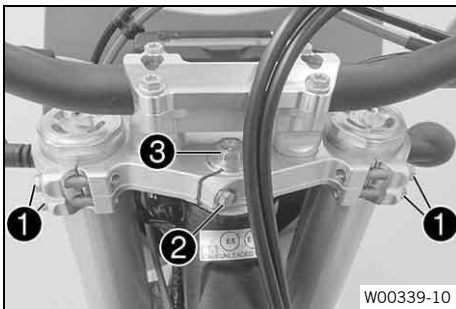

- Using a plastic hammer, tap lightly on the upper triple clamp to avoid stresses.
- Tighten screws **1**.

Screw, top triple clamp	
M20×1.5	12 Nm
<b>(All except SIX DAYS)</b>	
M8	20 Nm
Screw, top triple clamp	
<b>(EXC-F SIX DAYS)</b>	
M8	17 Nm

- Remove screw **2**.
- Mount and tighten screw **2**.

Screw, upper steering stem	
M8	20 Nm
<b>Loctite® 243</b>	

## Reworking

- Check the steering head bearing play. 📖 (p. 72)
- Remove the motorcycle from the lift stand. 📖 (p. 65)

### 12.15 Lubricating the steering head bearing 🛠️

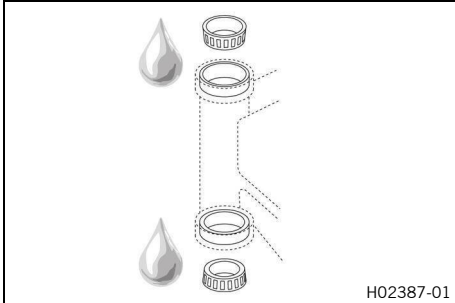

- Remove the lower triple clamp. 🛠️ 📖 (p. 69)
- Install the lower triple clamp. 🛠️ 📖 (p. 70)

#### **i** Note

The steering head bearing is cleaned and lubricated in the course of removal and installation of the lower triple clamp.

### 12.16 Removing the front top fender

#### Preparatory work

- Remove the headlight mask with the headlight. 📖 (p. 123)

#### Removal process

- Remove ① screws.

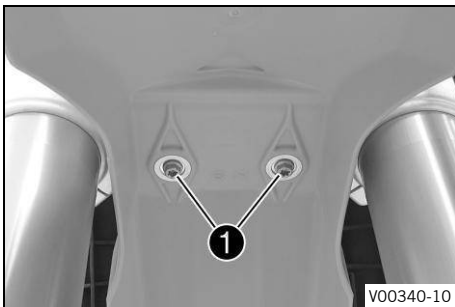

- Remove screws ② and take off the fender at the front.

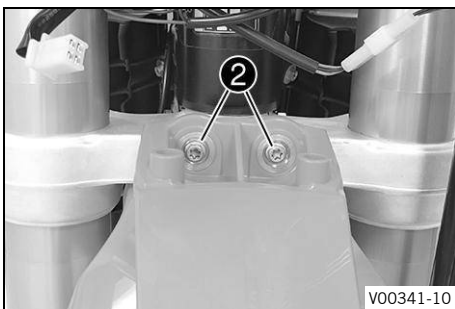

## 12.17 Installing the front top fender

### Installation procedure

- Position the front fender, install screws ❶ and tighten.

Remaining screws on chassis	
M6	10 Nm

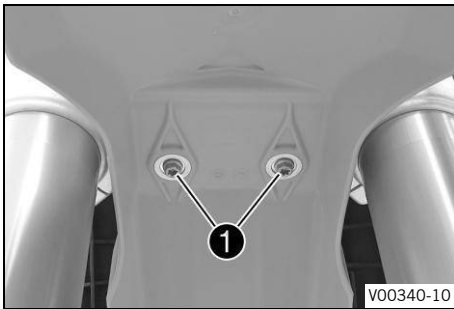

- Mount and tighten screws ❷.

Remaining screws on chassis	
M6	10 Nm

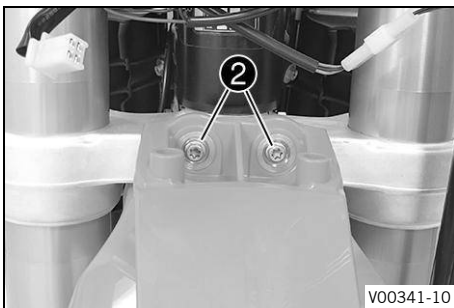

### Reworking

- Install the headlight mask with the headlight. 📖 (p. 124)
- Check the headlight setting. 📖 (p. 125)



## 12.18 Removing the shock absorber 🛠️

### Preparatory work

- Raise the motorcycle with a lift stand. 📖 (p. 65)
- Remove the seat. 📖 (p. 78)
- Remove the frame protector. 📖 (p. 67)
- Remove the muffler. 📖 (p. 82)

### Removal process

- Remove screws ❶. Disconnect the plug-in connectors for the tail light and turn signals.
- Remove screws ❷ and screws ❸.
- Take off the license plate holder with tail light toward the rear.

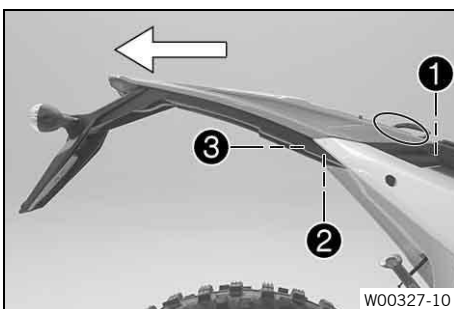

## 12 Service work on the chassis



- Remove screw ④.
- Remove screw ⑤.
- Carefully take off the right side cover to the side.



### Note

The right side cover also engages behind the spoiler.



- Carefully remove retaining spring ⑥.
- Remove rear half of manifold ⑦ to the rear.



- Remove screw ⑧ and lower the rear wheel with the link fork as far as possible without blocking the rear wheel. Secure the rear wheel in this position.
- Remove screw ⑨, push splash protector ⑩ to the side, and remove the shock absorber.

### 12.19 Installing the shock absorber

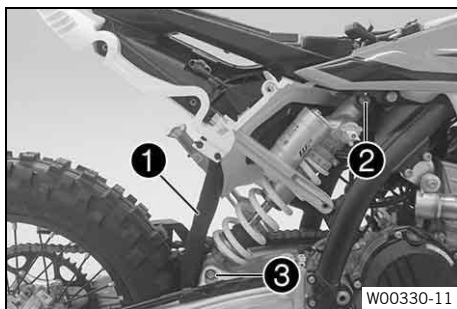

#### Installation procedure

- Push splash protector ① to the side and position the shock absorber. Mount and tighten screw ②.

Top shock absorber screw	
M12	80 Nm <b>Loctite® 2701</b>

- Mount and tighten screw ③.

Bottom shock absorber screw	
M12	80 Nm <b>Loctite® 2701</b>



### Note

The heim joint for the shock absorber on the link fork is Teflon coated. It must not be lubricated with grease, nor with any other lubricants. Lubricants dissolve the Teflon coating, thereby drastically reducing the service life.



- Slip in rear half of manifold **4** from behind and position it.
- Attach retaining springs **5**.

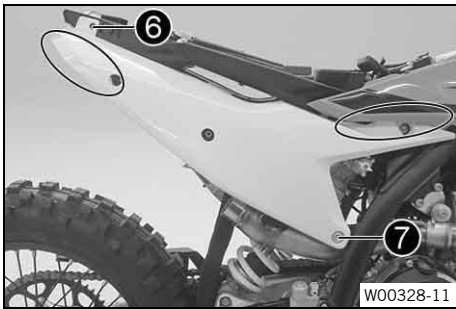

- Position the right side fairing on the tail section.
- Position the right side fairing correctly behind the spoiler.

Ensure that it is correctly seated on the tail section.
---

- Mount and tighten screw **6**.

Tighten screw hand-tight.
---------------------------

- Mount and tighten screw **7**.

Screw, subframe, bottom	
M8	30 Nm
<b>Loctite® 2701</b>	

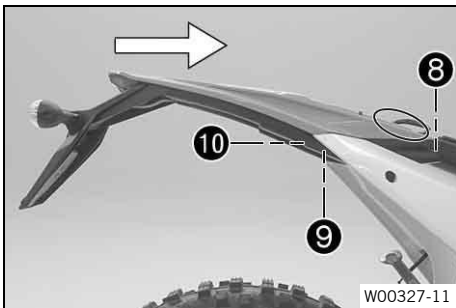

- Slide the license plate holder with tail light carefully onto the tail section.
- Pay attention to cable routing.
- Mount and tighten screws **8**.

Remaining screws on chassis	
M6	10 Nm

- Plug in the connectors for the tail light and turn signals and order them properly.

- Mount and tighten screws **9**.

Remaining screws on chassis	
M6	10 Nm

- Mount and tighten screws **10**.

Remaining screws on chassis	
<b>EJOT PT®</b> – K60×25 – Z	2 Nm

### Reworking

- Install the muffler. 📖 (p. 83)
- Install the frame protector. 📖 (p. 67)
- Mount the seat. 📖 (p. 78)
- Remove the motorcycle from the lift stand. 📖 (p. 65)

## 12.20 Removing the seat

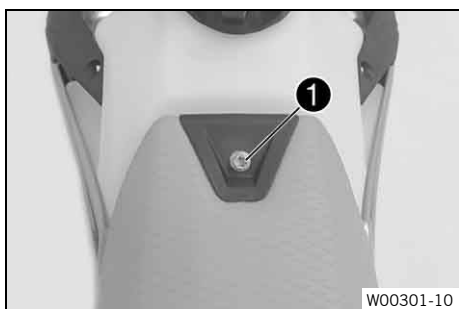

- Remove screw **1**.

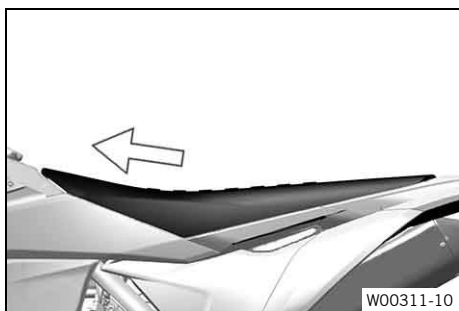

- Raise seat, pull it toward the fuel tank and take it off.

## 12.21 Mounting the seat

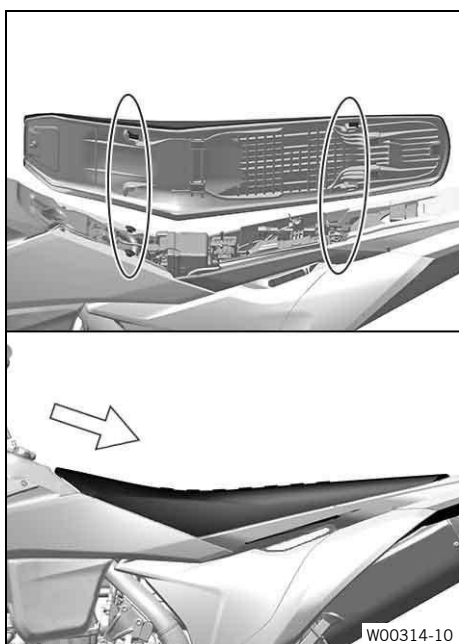

- Mount the front of the seat on the collar bushings of the fuel tank, lower the seat at the rear, and push the seat to the rear.
  - ✓ The holding lugs engage in the recesses at the back.
- Make sure the seat is latched in place correctly.

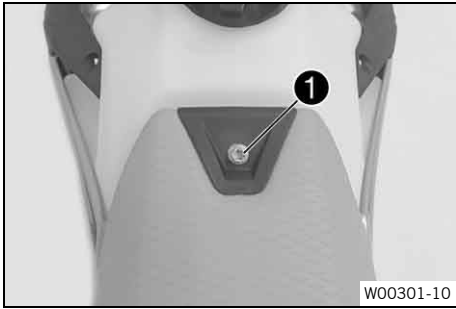

- Mount and tighten screw ①.

Remaining screws on chassis	
M6	10 Nm

## 12.22 Removing air filter box cover

Condition: Air filter box cover secured



- Remove screw ①.

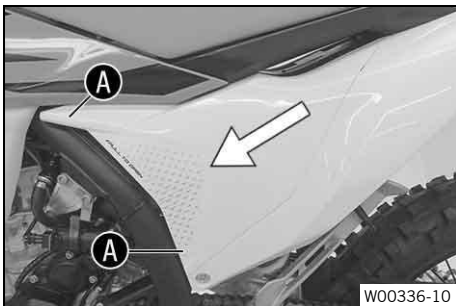

- Pull off the air filter box cover in area ①, push it forwards to the side and remove it.

Condition: Air filter box cover not secured

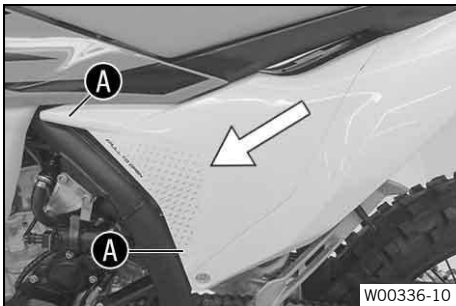

- Pull off the air filter box cover in area ①, push it forwards to the side and remove it.

## 12.23 Installing air filter box cover

Condition: Air filter box cover secured

- Attach air filter box cover in area **A** and engage it in area **B**.

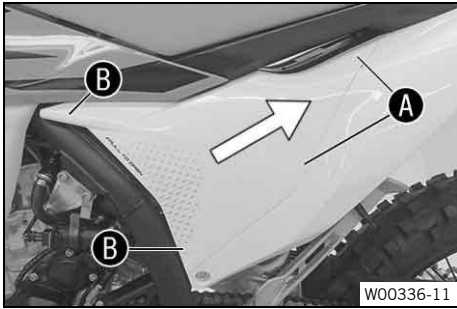

- Mount and tighten screw **1**.

Screw, air filter box cover	
EJOT PT® – MK60×20 – Z	3 Nm

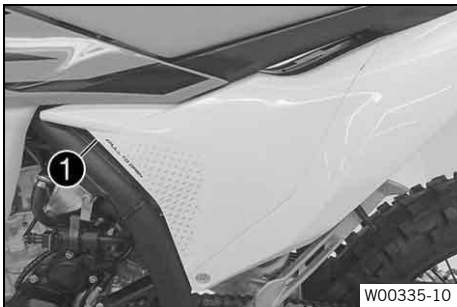

Condition: Air filter box cover not secured

- Attach air filter box cover in area **A** and engage it in area **B**.

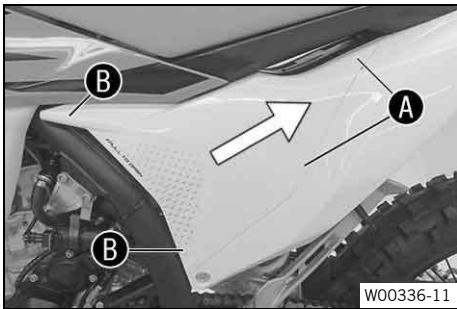

## 12.24 Removing the air filter



### NOTE

**Environmental hazard** Hazardous substances cause environmental damage.

- Dispose of oils, grease, filters, fuel, cleaning agents, brake fluid, etc. correctly and in accordance with the applicable regulations.



### NOTE

**Engine failure** Unfiltered intake air has a negative effect on the service life of the engine.

Dust and dirt can enter the engine if there is no air filter or if the air filter is mounted incorrectly.

- Only operate the vehicle if an air filter is correctly fitted.

### Preparatory work

- Remove air filter box cover. (p. 79)

## Removal process

- Detach tab ❶.
- Remove air filter with air filter support.
- Remove the air filter with the air filter support.

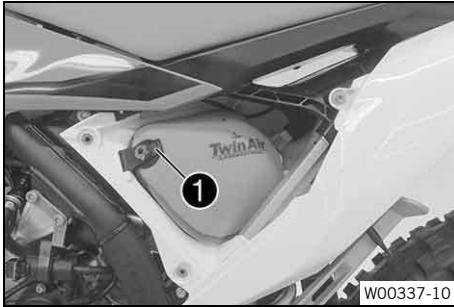

## 12.25 Installing the air filter

### Installation procedure

- Mount the clean air filter on the air filter support.
- Grease the air filter in area A.

Long-life grease (p. 165)

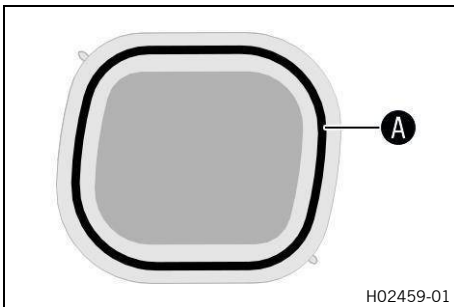

- Insert air filter and position retaining pin ❶ in bushing B.
- ✓ The air filter is correctly positioned.
- Secure the bottom retaining pin ❸ with holding tab ❷.

**i Note**  
If the air filter is not mounted correctly, dust and dirt may enter the engine and result in damage.

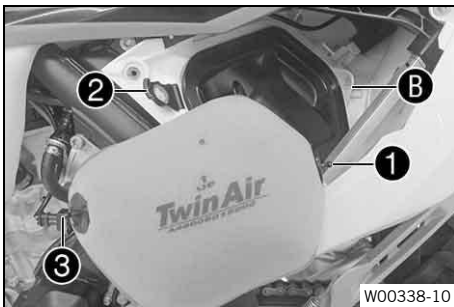

### Reworking

- Install the air filter box cover. (p. 80)

## 12.26 Cleaning the air filter and air filter box



### NOTE

**Environmental hazard** Hazardous substances cause environmental damage.

- Dispose of oils, grease, filters, fuel, cleaning agents, brake fluid, etc. correctly and in accordance with the applicable regulations.

### Preparatory work

- Remove air filter box cover. (p. 79)
- Remove the air filter. (p. 80)

## 12 Service work on the chassis



### Cleaning process

- Wash the air filter thoroughly in special cleaning liquid and allow it to dry properly.

Do not clean the air filter with fuel or petroleum as these substances will damage the foam rubber.
---

Only press the air filter to dry it, do not wring it out.
---

Air filter cleaning agent  (p. 168)
--

- Oil the dry air filter with a high-grade air filter oil.

Oil for foam air filter  (p. 166)
--

- Clean the air filter box.
- Check intake flange for damage and looseness.

### Reworking

- Install the air filter.   (p. 81)
- Install the air filter box cover.  (p. 80)

## 12.27 Preparing the air filter box cover for securing

### Preparatory work

- Remove air filter box cover.  (p. 79)

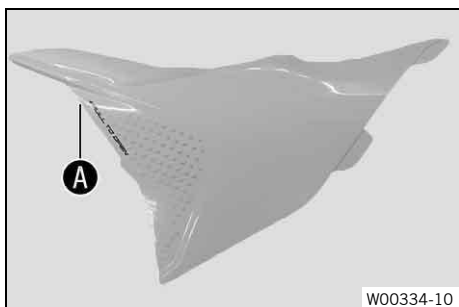

### Installation procedure

- Drill a hole at marking **A**.

Diameter	6 mm
----------	------

### Reworking

- Install the air filter box cover.  (p. 80)

## 12.28 Removing the muffler



### WARNING

**Danger of burns** The exhaust system gets hot when the vehicle is driven.

- Allow the exhaust system to cool down before performing any work on the vehicle.

(All EU / AR / BR models)

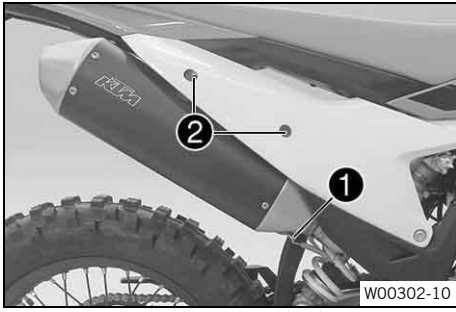

W00302-10

- Detach spring ①.

Spring hook (50305017000C1)
-----------------------------

- Remove screws ② and take off the main silencer with the catalytic converter.

**(XW-F)**

- Detach spring ①.

Spring hook (50305017000C1)
-----------------------------

- Remove screws ② and take off the main silencer.

## 12.29 Installing muffler

**(All EU / AR / BR models)**

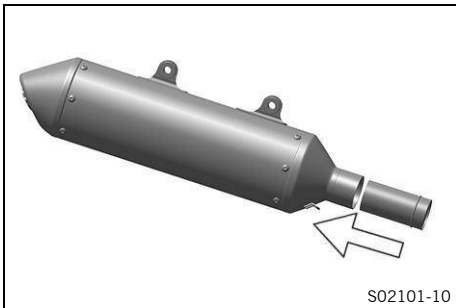

S02101-10

- Position the catalytic converter in the main silencer.

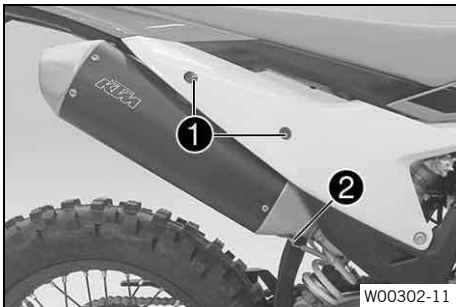

W00302-11

- Position the main silencer. Mount and tighten screws ① but do not tighten yet.
- Attach spring ②.

Spring hook (50305017000C1)
-----------------------------

- Tighten screws ①.

Remaining screws on chassis	
-----------------------------	--

M6	10 Nm
----	-------

## 12.30 clean spark arrestor (XW-F)



**WARNING**

**Danger of burns** The exhaust system gets hot when the vehicle is driven.

- Allow the exhaust system to cool down before performing any work on the vehicle.



**Note**

Soot particles accumulate on the screen of the spark arrestor over time. This changes the performance characteristics.

## Preparatory work

- Remove the muffler.  (p. 82)

## Cleaning process

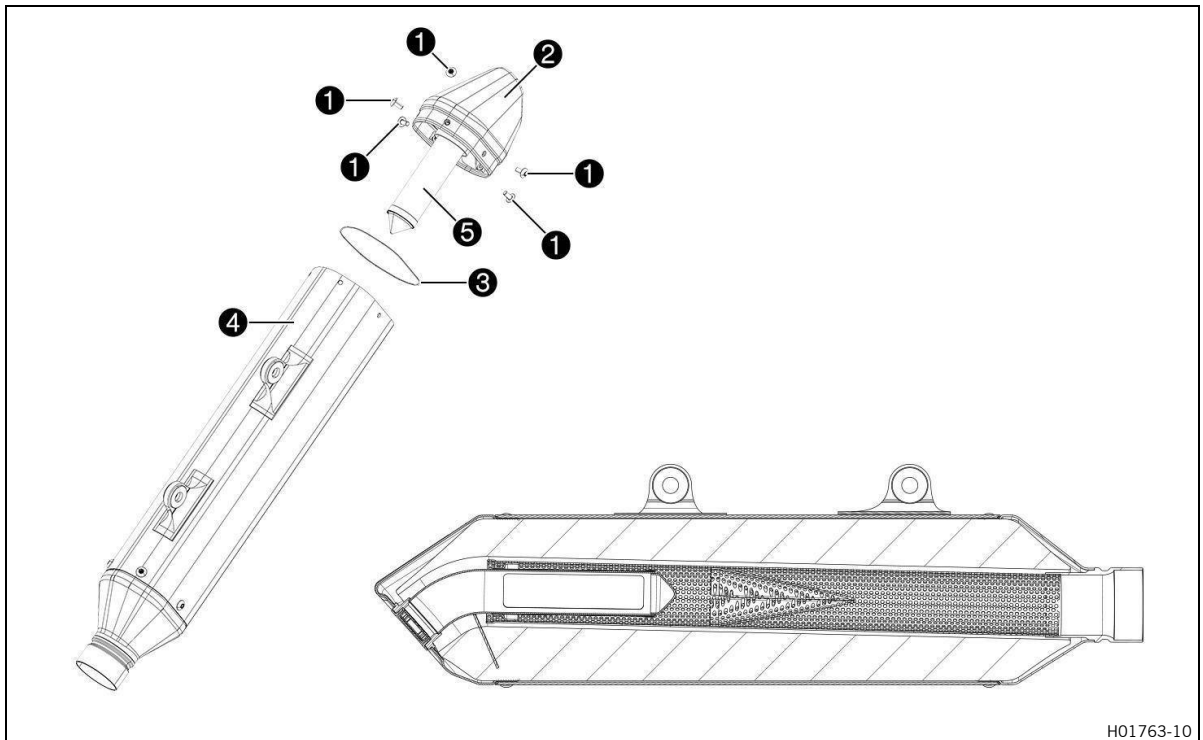

H01763-10

- Remove screws **1** and take off silencer cap **2** with O-ring **3**.
- Do not remove the glass fiber filling.



### CAUTION

**Health hazard** Soot particles irritate the eyes and mucuous membranes.

- Wear suitable breathing and eye protection when cleaning the main silencer and carbon screen.

- Clean main silencer sleeve **4** and screen **5** of the spark arrestor with compressed air.
- Mount new O-ring **3** on silencer cap **2**.
- Position silencer cap **2**. Mount and tighten screws **1**.

Screws on muffler	
M5	7 Nm

## Reworking

- Install the muffler.  (p. 83)

## 12.31 Changing the glass fiber filling of the muffler



### WARNING

- Danger of burns** The exhaust system gets hot when the vehicle is driven.
- Allow the exhaust system to cool down before performing any work on the vehicle.



### Note

Over time, the fibers of the glass fiber yarn filling escape and the damper "burns" out. Not only does this make the noise level higher, but the performance characteristics also change.

### Preparatory work

- Remove the muffler.  (p. 82)

### Replacement process

(All EU / AR / BR models)

- Remove ① screws.
- Take off silencer cap ② with O-ring ③.
- Remove the old glass fiber filling.
- Clean the parts that need to be reinstalled and check for damage.
- Insert new glass fiber filling ④ in the muffler.
- Mount the O-ring on the silencer cap.
- Position the silencer cap.
- Mount and tighten all of the screws.

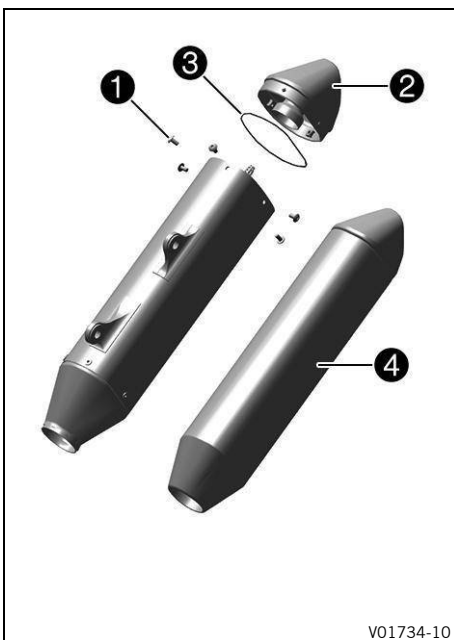

Screws on muffler	
M5	7 Nm

### Reworking

- Install the muffler.  (p. 83)



## 12.32 Removing the fuel tank



### DANGER

**Fire hazard** Fuel is highly flammable.

The fuel in the fuel tank expands when warm and can escape if overfilled.

- Do not refuel the vehicle in the vicinity of open flames, glowing, or smoldering objects.
- Make sure that nobody smokes in the vicinity of the vehicle during the refueling process.
- Switch off the engine for refueling.
- Make sure that no fuel is spilled; particularly not on hot parts of the vehicle.

- If any fuel is spilled, wipe it up immediately.
- Do not overfill the fuel tank.



## WARNING

**Danger of poisoning** Fuel is harmful to health.

- Do not allow fuel to come into contact with skin, eyes, or clothing.
- Consult a doctor immediately if fuel has been ingested.
- Do not inhale fuel vapors.
- Rinse the affected area immediately with plenty of water in the event of contact with skin.
- Rinse eyes thoroughly with water and consult a doctor immediately if fuel comes into contact with eyes.
- If fuel spills on to your clothing, change the clothing.
- Store fuel properly in a suitable container and keep out of the reach of children.

## Preparatory work

- Remove the seat. (p. 78)

## Removal process

- Clean quick-lock coupling **1** thoroughly with compressed air.

Dirt must not enter into the fuel line.



### Note

Dirt in the fuel line clogs the injector!

- Disconnect the quick-lock coupling.



### Note

Remaining fuel may flow out of the fuel line.

- Mount wash cap set **2**.

Wash cap set (81212016100)

- Unplug socket connector **3** of the fuel pump.
- Remove screws **4** with rubber bushing.
- Remove the hose from the fuel tank breather.

- Remove **5** screws.
- Hang the horn and horn bracket to one side.

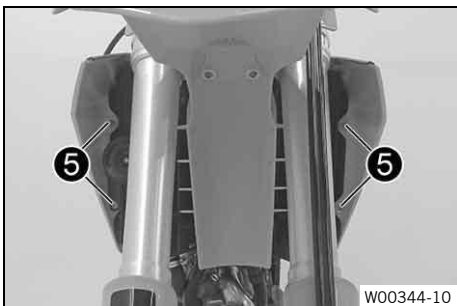
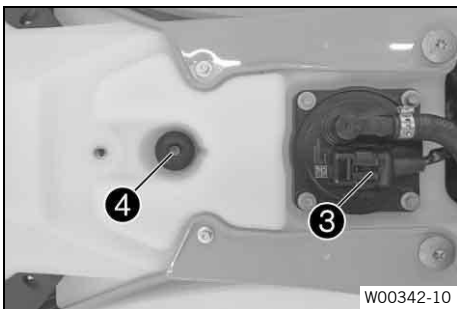
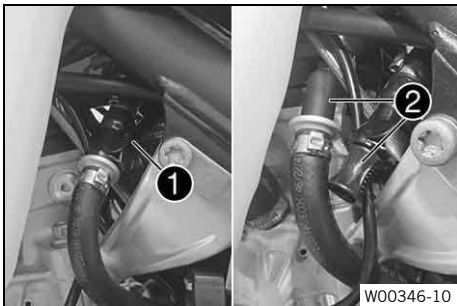

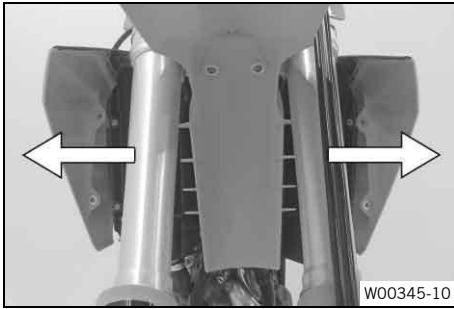

- Pull both spoilers laterally off the radiator and lift off the fuel tank.

## 12.33 Installing the fuel tank



### DANGER

**Fire hazard** Fuel is highly flammable.

The fuel in the fuel tank expands when warm and can escape if overfilled.

- Do not refuel the vehicle in the vicinity of open flames, glowing, or smoldering objects.
- Make sure that nobody smokes in the vicinity of the vehicle during the refueling process.
- Switch off the engine for refueling.
- Make sure that no fuel is spilled; particularly not on hot parts of the vehicle.
- If any fuel is spilled, wipe it up immediately.
- Do not overfill the fuel tank.



### WARNING

**Danger of poisoning** Fuel is harmful to health.

- Do not allow fuel to come into contact with skin, eyes, or clothing.
- Consult a doctor immediately if fuel has been ingested.
- Do not inhale fuel vapors.
- Rinse the affected area immediately with plenty of water in the event of contact with skin.
- Rinse eyes thoroughly with water and consult a doctor immediately if fuel comes into contact with eyes.
- If fuel spills on to your clothing, change the clothing.
- Store fuel properly in a suitable container and keep out of the reach of children.

### Installation procedure

#### Checking the throttle cable routing



### WARNING

**Danger of accidents** The throttle cable can become kinked, jammed, or blocked if it has been routed incorrectly.

If the throttle cable is kinked, jammed or blocked, the speed can no longer be controlled.

- Make sure that the throttle cable routing and the play in the throttle cable complies with the specification.

## 12 Service work on the chassis

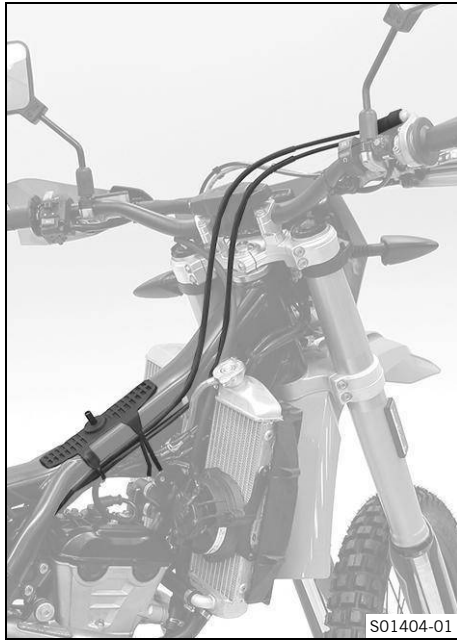

- Check the throttle cable routing.

Both throttle cables must be routed, side by side, on the back of the handlebars and above the fuel tank bracket, to the throttle valve body. Both throttle cables must be secured behind the rubber bands of the fuel tank support.

- » If the throttle cable routing is not as specified:
  - Correct the throttle cable routing.

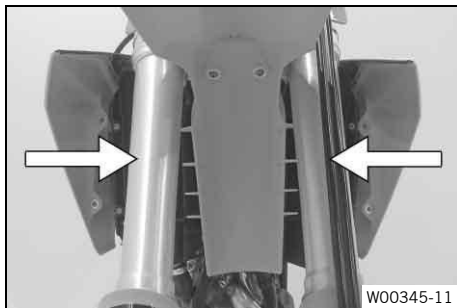

- Position the fuel tank and fit the two spoilers to the sides in front of the radiator bracket.
- Make sure that no wires or cables are trapped or damaged.

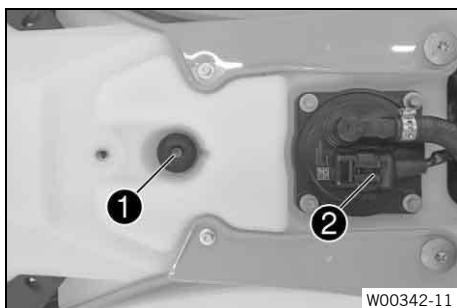

- Attach the fuel tank breather hose.
- Mount and tighten screw **1** with the rubber bushing.

Remaining screws on chassis	
M6	10 Nm

M6	10 Nm
----	-------

- Plug in fuel pump socket connector **2**.

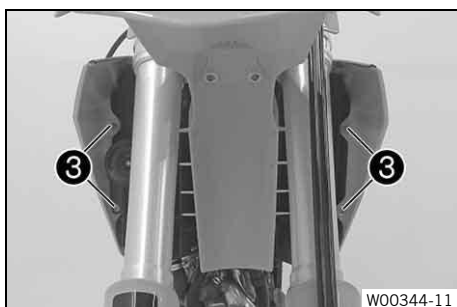

- Position the horn with the horn bracket.
- Mount and tighten screws **3**.

Remaining screws on chassis	
M6	10 Nm

M6	10 Nm
----	-------

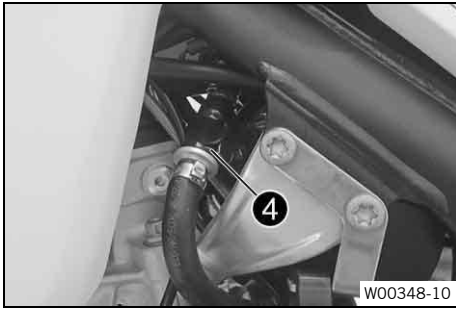

- Remove the wash cap set.
- Clean the quick release coupling thoroughly with compressed air.

**i Note**  
Under no circumstances should dirt enter into the fuel line. Dirt in the fuel hose clogs the injector!

- Spray silicone spray onto a lint-free cleaning cloth and lightly lubricate the O-ring of the quick-lock coupling.

Silicone spray (p. 166)

- Join quick release coupling ④.

**i Note**  
Route the wire and fuel line at a safe distance from the exhaust system.

### Reworking

- Mount the seat. (p. 78)



## 12.34 Checking the chain for dirt

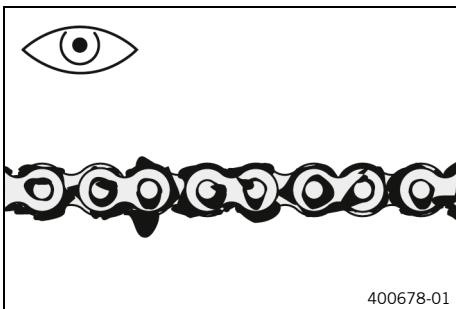

- Check the chain for coarse dirt accumulation.
  - » If the chain is very dirty:
    - Clean the chain. (p. 89)



## 12.35 Cleaning the chain

**! WARNING**  
**Danger of accidents** Lubricants on the tires reduces the road grip.  
- Remove lubricants from the tires using a suitable cleaning agent.

**! WARNING**  
**Danger of accidents** Oil, grease or wax on the brake discs reduces the brake action.  
- Always keep the brake discs free of oil, fat and wax.  
- Clean the brake discs with brake cleaner when necessary.

**🌸 NOTE**  
**Environmental hazard** Hazardous substances cause environmental damage.  
- Dispose of oils, grease, filters, fuel, cleaning agents, brake fluid, etc. correctly and in accordance with the applicable regulations.



## Note

The service life of the chain depends largely on its maintenance.

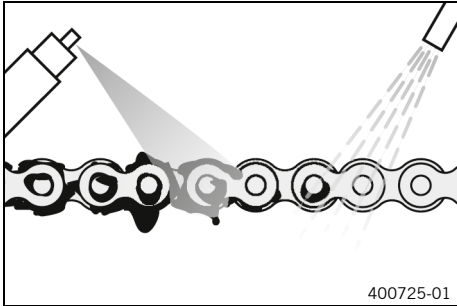

## Preparatory work

- Raise the motorcycle with a lift stand. (p. 65)

## Cleaning process

- Rinse off the loose dirt with a gentle jet of water.
- Remove old grease residues with a chain cleaner.

Chain cleaner (p. 168)

- After drying, apply chain spray.

Off-road chain spray (p. 165)

## Reworking

- Remove the motorcycle from the lift stand. (p. 65)

## 12.36 Checking the chain tension



## WARNING

**Danger of accidents** Incorrect chain tension can damage components and result in an accident.

If the chain tension is too high, the chain, front sprocket, rear sprocket, transmission, and rear wheel bearings wear more quickly. Some components may break if overloaded.

If the chain is too loose, the chain may fall off the front sprocket or the rear sprocket. This can damage the rear wheel or the engine.

- Check the chain tension regularly.
- Set the chain tension in accordance with the specification.

## Preparatory work

- Raise the motorcycle with a lift stand. (p. 65)

## Control process

- Pull the chain at the end of the chain slider upward to measure chain tension **A**.

Chain tension	58 mm ... 61 mm
Lower chain section <b>1</b> must be taut.	
When the chain guard is mounted, it must be possible to pull up the chain at least to the point where it makes contact with chain guard <b>B</b> .	
Repeat this measurement at different chain positions.	

**i Note**  
Chains do not always wear evenly.

- » If the chain tension does not meet the specification:
  - Adjust the chain tension. 📖 (p. 91)

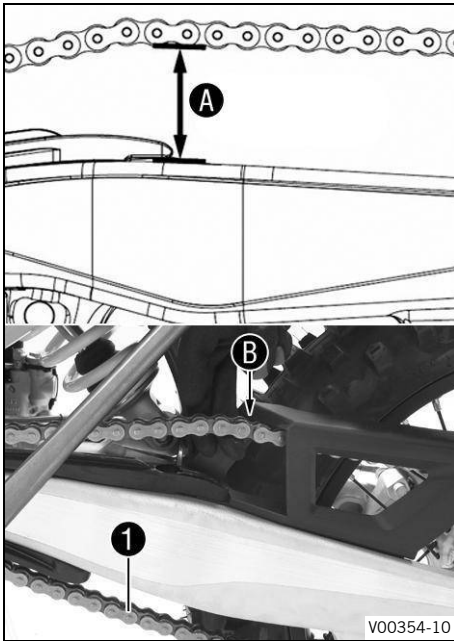

## Reworking

- Remove the motorcycle from the lift stand. 📖 (p. 65)

## 12.37 Adjusting the chain tension



### WARNING

**Danger of accidents** Incorrect chain tension can damage components and result in an accident.

If the chain tension is too high, the chain, front sprocket, rear sprocket, transmission, and rear wheel bearings wear more quickly. Some components may break if overloaded.

If the chain is too loose, the chain may fall off the front sprocket or the rear sprocket. This can damage the rear wheel or the engine.

- Check the chain tension regularly.
- Set the chain tension in accordance with the specification.

## Preparatory work

- Raise the motorcycle with a lift stand. 📖 (p. 65)
- Check the chain tension. 📖 (p. 90)

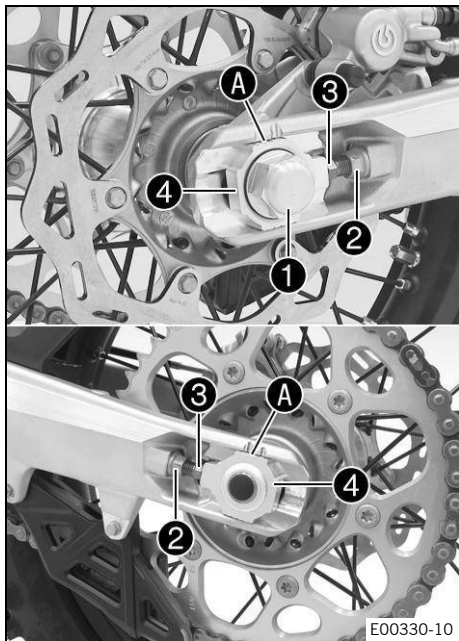

## Adjustment procedure

- Loosen nut ①.
- Loosen nuts ②.
- Adjust the chain tension by turning adjusting screws ③ on the left and right.

Chain tension	58 mm ... 61 mm
Turn adjusting screws ③ on the left and right so that the markings on the left and right chain tension adjusters are in the same position relative to reference marks A. The rear wheel is then correctly aligned.	

- Tighten nuts ②.
- Make sure that chain tension adjusters ④ are fitted correctly on adjusting screws ③.
- Tighten nut ①.

Nut, wheel spindle, rear	
M22	80 Nm

**Note**  
The wide adjustment range of the chain adjusters enables different secondary ratios with the same chain length.  
Chain tension adjusters ④ can be turned by 180°.

## Reworking

- Remove the motorcycle from the lift stand. 📖 (p. 65)

## 12.38 Checking the chain, rear sprocket, and chain guide

### Preparatory work

- Raise the motorcycle with a lift stand. 📖 (p. 65)

### Control process

- Shift the transmission into the neutral position.
- Check the chain, rear sprocket, and front sprocket for wear.
  - » If the chain, rear sprocket, or front sprocket is worn:
    - Change the drivetrain kit. 🛠️

The front sprocket, rear sprocket, and chain should always be replaced together.

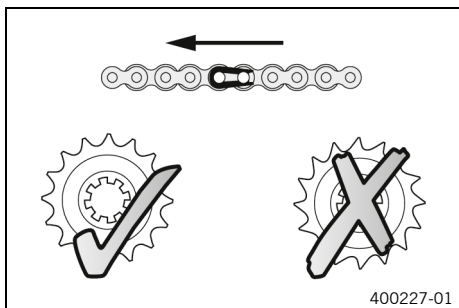

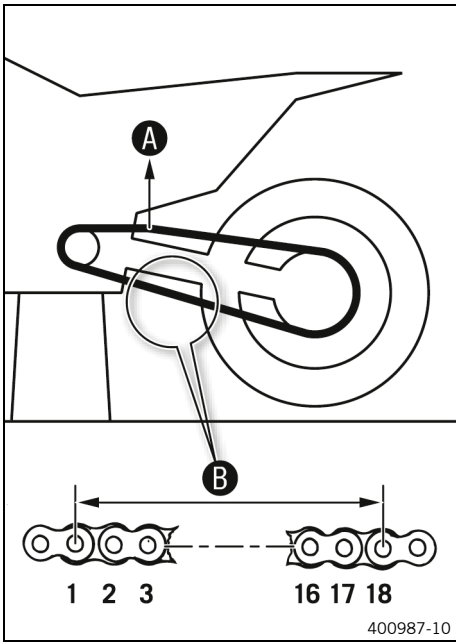

- Pull on the top section of the chain with the specified weight **A**.

Weight, chain wear measurement	10 kg ... 15 kg
--------------------------------	-----------------

- Measure distance **B** of chain rollers in the lower chain section.

Maximum distance <b>B</b> of chain rollers at the longest chain section	272 mm
Repeat this measurement at different chain positions.	

**i Note**  
Chains do not always wear evenly.

- » If distance **B** is greater than the specified measurement:
  - Change the drivetrain kit. 🔧

When a new chain is fitted, the rear sprocket and front sprocket should also be replaced.
---

**i Note**  
New chains wear out faster on old, worn sprockets.

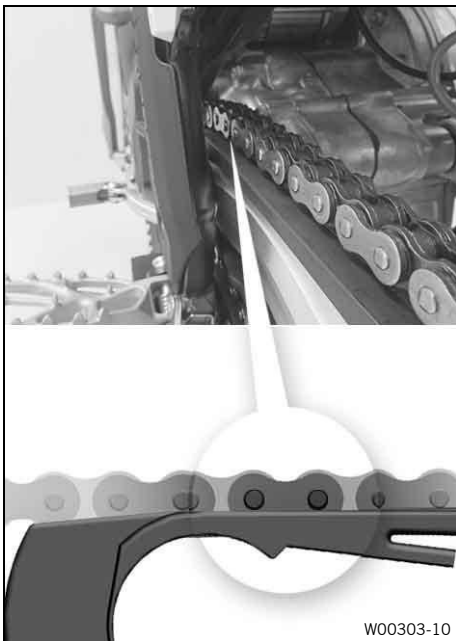

- Check the chain slider at the top for wear.
  - » If the lower edge of the chain pins is in line with, or below, the chain slider:
    - Change the chain slider. 🔧
- Check that the chain slider is firmly seated.
  - » If the chain slider is loose:
    - Tighten the screws of the chain slider.

Screw, chain slider guard	
M6	6 Nm
<b>Loctite® 243</b>	

# 12 Service work on the chassis

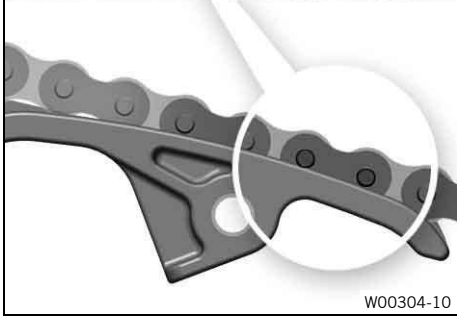
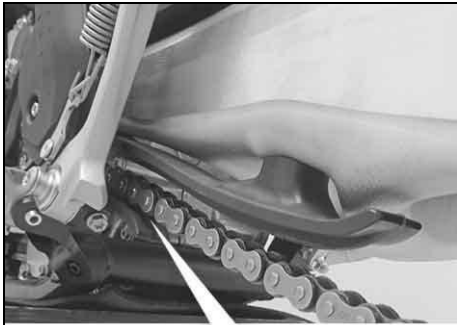

W00304-10

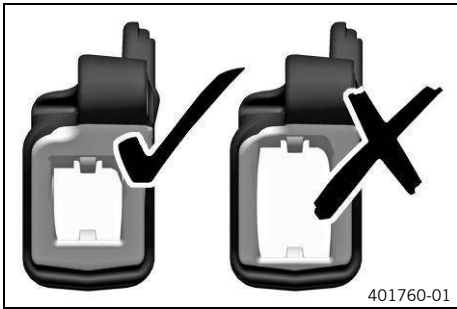

401760-01



W00305-10

- Check the chain slider for wear.
  - » If the lower edge of the chain pins is in line with or below the chain slider:
    - Change the chain slider. 🛠️
- Check that the chain slider is firmly seated.
  - » If the chain slider is loose:
    - Tighten the screw of the chain sliding piece.

Screw, chain slider	
M8	15 Nm

- Check the chain guide for wear.



**Note**

Wear can be seen on the front of the chain guide.

- » If the light part of the chain guide is worn:
  - Change the chain guide. 🛠️

- Check that the chain guide is firmly seated.
  - » If the chain guide is loose:
    - Tighten the screws on the chain guide.

Remaining screws on chassis	
M6	10 Nm
Remaining nuts on chassis	
M6	10 Nm

**Reworking**

- Remove the motorcycle from the lift stand. 📖 (p. 65)

## 12.39 Checking the frame

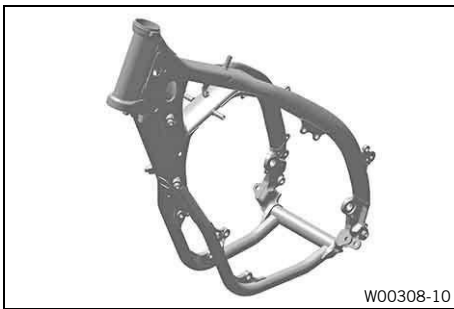



- Check the frame for damage, cracks, and deformation.
  - » If the frame shows signs of damage, cracks, or deformation:
    - Change the frame. 

Repairs on the frame are not permitted. 

## 12.40 Checking the swingarm



- Check the swingarm for damage, cracks, and deformation.
  - » If the swingarm shows signs of damage, cracks, or deformation:
    - Change the swingarm. 

Always replace a damaged link fork. Repairing the link fork is not authorized by KTM. 

## 12.41 Checking the throttle cable routing





### WARNING

**Danger of accidents** The throttle cable can become kinked, jammed, or blocked if it has been routed incorrectly.

If the throttle cable is kinked, jammed or blocked, the speed can no longer be controlled.

- Make sure that the throttle cable routing and the play in the throttle cable complies with the specification.

### Preparatory work

- Remove the seat.  (p. 78)
- Remove the fuel tank.   (p. 85)

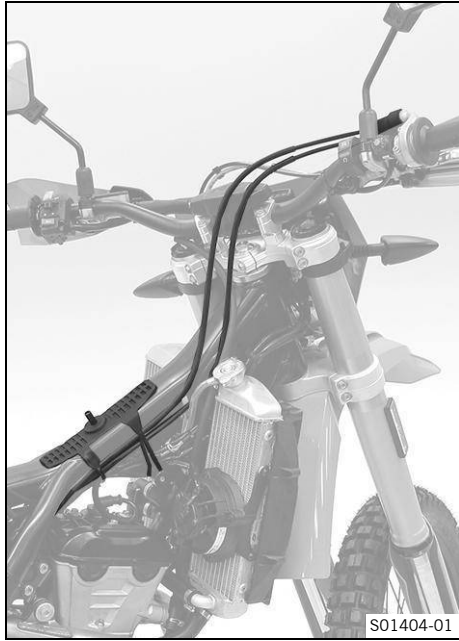



### Control process

- Check the throttle cable routing.

Both throttle cables must be routed, side by side, on the back of the handlebars and above the fuel tank bracket, to the throttle valve body. Both throttle cables must be secured behind the rubber bands of the fuel tank support.

- » If the throttle cable routing is not as specified:
  - Correct the throttle cable routing.

### Reworking

- Install the fuel tank.   (p. 87)
- Mount the seat.  (p. 78)

## 12.42 Checking the hand grip

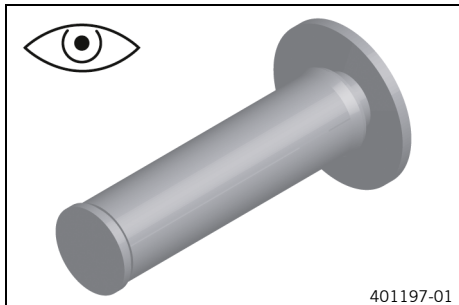

- Check the hand grips on the handlebar for damage, wear, and that they are firmly seated.

**i Note**  
The hand grips are vulcanized onto a sleeve on the left and onto the grip tube of the throttle grip on the right. The left sleeve is clamped onto the handlebar. The hand grip can only be replaced with the sleeve or the gas pipe.

- » If a rubber grip is damaged, worn, or loose:
  - Replace the hand grip.

- Check that screw **1** is firmly seated.

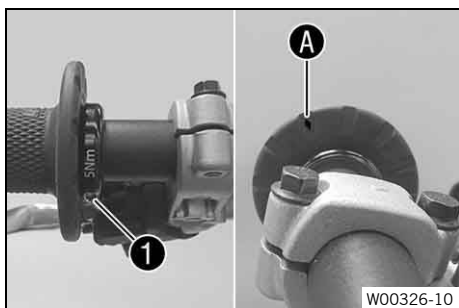

Screw, fixed grip	
M4	5 Nm
<b>Loctite® 243</b>	

Diamond **A** must be located at the top.

## 12.43 Program the Quickshifter (EXC-F BR / EXC-F SIX DAYS)

**i Note**

If the shifting performance of the Quickshifter starts to decrease, it must be reprogrammed.



- Carry out the starting procedure. (p. 45)
- Press and hold the QS button **1** for at least 10 seconds.
  - ✓ The QS indicator lamp flashes.
- Pull the clutch lever, engage first-gear and hold the shift lever all the way down.
- Briefly press the QS button **1**.
  - ✓ The QS indicator lamp lights up blue, the teaching procedure was successful.

**i Note**

If the quickshifter cannot be activated, the teaching procedure was unsuccessful and must be repeated.

## 12.44 Checking/correcting the fluid level of hydraulic clutch



**WARNING**

**Health hazard** Brake fluid is a harmful substance.

- Keep brake fluid out of the reach of children.
- Wear suitable protective clothing and safety glasses.
- Do not allow brake fluid to come into contact with the skin, the eyes, or clothing.
- Consult a doctor immediately if brake fluid has been ingested.
- Rinse the affected area with plenty of water in the event of contact with the skin.
- Rinse eyes thoroughly with water immediately and consult a doctor if brake fluid comes into contact with the eyes.
- If brake fluid spills on to your clothing, change the clothing.



**NOTE**

**Environmental hazard** Hazardous substances cause environmental damage.

- Dispose of oils, grease, filters, fuel, cleaning agents, brake fluid, etc. correctly and in accordance with the applicable regulations.

**i Note**

The fluid level rises with increasing wear of the friction plates.  
Avoid contact between brake fluid and painted parts. Brake fluid corrodes paint.

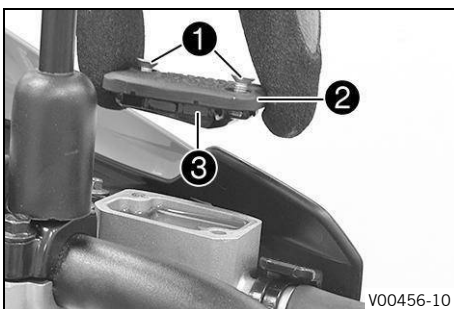

- Move the hydraulic clutch fluid reservoir mounted on the handlebar into a horizontal position.
- Remove **1** screws.
- Take off cover **2** with diaphragm **3**.
- Check the fluid level.

Fluid level below reservoir rim	4 mm
---------------------------------	------

- » If the fluid level does not meet the specifications:
  - Correct the fluid level of the hydraulic clutch.

Brake fluid DOT 4 / DOT 5.1  (p. 166)

- Position the cover with diaphragm.
- Mount and tighten the screws.

Immediately clean up any brake fluid that has overflowed or spilled with water.

## 12.45 Adjusting the basic position of the clutch lever

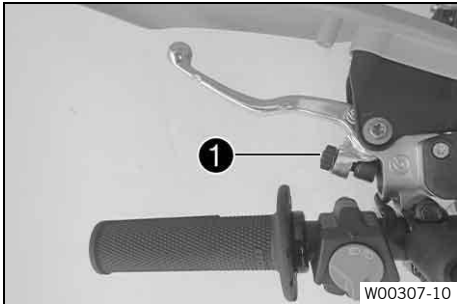

- Adjust the basic position of the clutch lever to your hand size by turning adjusting screw ①.

Only turn the adjusting screw by hand, and do not use force.

Do not make any adjustments while riding.

- Note**  
When the adjusting screw is turned clockwise, the clutch lever moves away from the handlebar.  
When the adjusting screw is turned counterclockwise, the clutch lever moves closer to the handlebar.  
The range of adjustment is limited.

## 12.46 Changing the hydraulic clutch fluid



### WARNING

**Health hazard** Brake fluid is a harmful substance.

- Keep brake fluid out of the reach of children.
- Wear suitable protective clothing and safety glasses.
- Do not allow brake fluid to come into contact with the skin, the eyes, or clothing.
- Consult a doctor immediately if brake fluid has been ingested.
- Rinse the affected area with plenty of water in the event of contact with the skin.
- Rinse eyes thoroughly with water immediately and consult a doctor if brake fluid comes into contact with the eyes.
- If brake fluid spills on to your clothing, change the clothing.



### NOTE

**Environmental hazard** Hazardous substances cause environmental damage.

- Dispose of oils, grease, filters, fuel, cleaning agents, brake fluid, etc. correctly and in accordance with the applicable regulations.



### Note

Avoid contact between brake fluid and painted parts. Brake fluid corrodes paint.

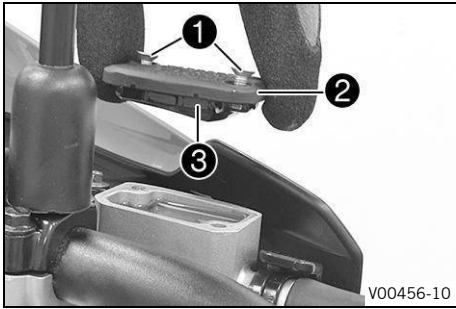

- Move the hydraulic clutch fluid reservoir mounted on the handlebar into a horizontal position.
- Remove ① screws.
- Take off cover ② with diaphragm ③.

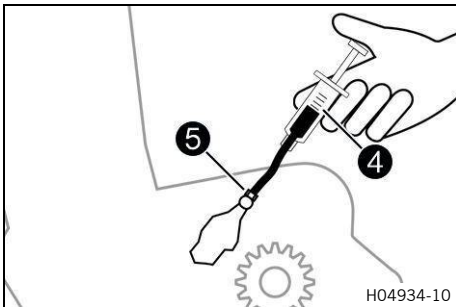

- Fill bleeding syringe ④ with the appropriate hydraulic fluid.

Syringe (50329050000)
Brake fluid DOT 4 / DOT 5.1  (p. 166)

- On the clutch slave cylinder, remove the protection cap, remove bleeder screw ⑤ and mount bleeding syringe ④.



- Keep pumping the fluid into the system until it comes out of openings ⑥ of the master cylinder without bubbles.
- Occasionally extract the fluid from the master cylinder reservoir to prevent overflowing.
- Remove the bleeding syringe.
- Mount and tighten the bleeder screw.
- Mount the protection cap.
- Correct the fluid level of the hydraulic clutch.

Fluid level below reservoir rim	4 mm
---------------------------------	------

- Position the cover with diaphragm.
- Mount and tighten the screws.

Immediately clean up any brake fluid that has overflowed or spilled with water.

## 12.47 Removing the skid plate (All special models / XW-F)

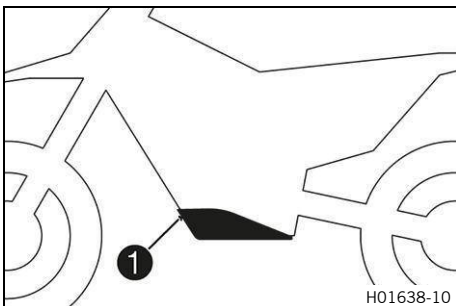

- Remove screws ① and engine guard.

## 12.48 Installing the skid plate (All special models / XW-F)

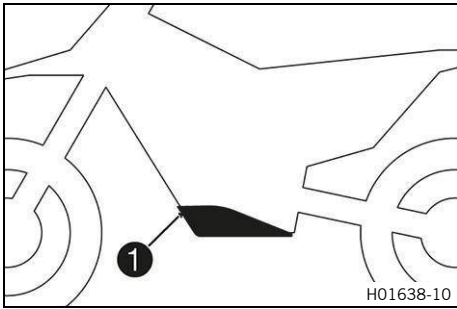

- Attach the engine guard on the frame at the rear and swing up at the front.
- Mount and tighten screws ①.

Remaining screws on chassis	
M6	10 Nm

## 13.1 Checking the free travel on the hand brake lever



### WARNING

**Danger of accidents** The brake system fails in the event of overheating.  
If there is no free travel on the brake lever, pressure builds up in the brake system.

- Set the free travel on the brake lever as specified.

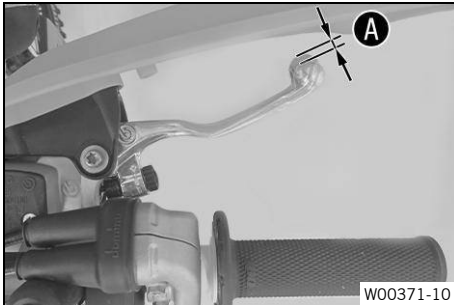

- Push the hand brake lever to the handlebar and check free travel **A**.

Free travel of hand brake lever	$\geq 3$ mm
---------------------------------	-------------

- » If the free travel does not meet the specifications:
  - Adjust the free travel of the handbrake lever. (p. 101)

## 13.2 Adjusting the free travel of the handbrake lever

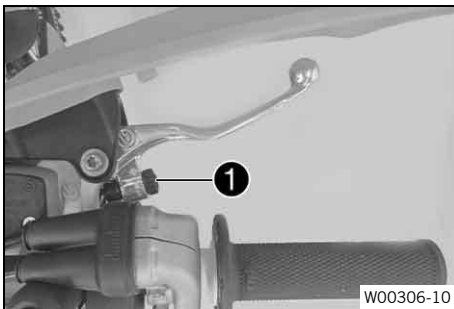

- Check the free travel on the hand brake lever. (p. 101)
- Adjust the free travel of the hand brake lever with adjusting screw **1**.



### Note

Turn the adjusting screw clockwise to reduce free travel. The pressure point moves away from the handlebar.  
Turn the adjusting screw counterclockwise to increase free travel. The pressure point moves towards the handlebar.  
The range of adjustment is limited.

- Only turn the adjusting screw by hand, and do not use force.
- Do not make any adjustments while riding.

## 13.3 Checking the brake discs



### WARNING

**Danger of accidents** Worn-out brake discs reduce the braking action.

- Make sure that worn-out brake discs are replaced immediately.

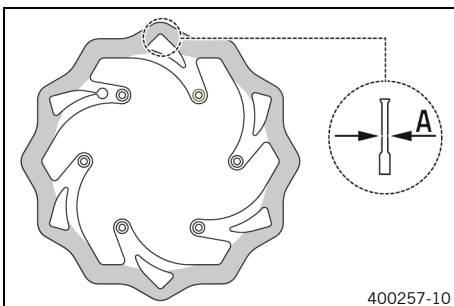





- Check the brake disc thickness of the front and rear brake disc at several places on the disc to see if they conform to measurement **A**.

Brake disc wear limit	
<b>(All except SIX DAYS)</b>	
front	2.5 mm
rear	3.5 mm
<b>(EXC-F SIX DAYS)</b>	
front	2.5 mm

rear	3.7 mm
------	--------

**Note**

Wear reduces the thickness of the brake discs at the contact surface of the brake pads.

- » If the brake disc thickness is less than the specified value:
  - Change the brake discs of the front brake. 
  - Change the brake discs on the rear brake. 
- Check the front and rear brake discs for damage, cracks, and deformation.
  - » If the brake disc shows signs of damage, cracks, or deformation:
    - Change the brake discs of the front brake. 
    - Change the brake discs on the rear brake. 

## 13.4 Checking the brake fluid level for the front brake



**WARNING**

**Danger of accidents** An insufficient brake fluid level will cause the brake system to fail.

If the brake fluid level drops below the specified marking or the specified value, the brake system has a leak or the brake pads are worn down.

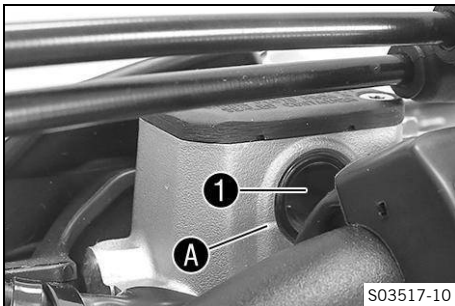
- Have the brake system checked and make sure that the problem has been eliminated before the vehicle is used again.



- Move the brake reservoir mounted on the handlebar to a horizontal position.
- Check the brake fluid level in sight glass **1**.
  - » If the brake fluid level has fallen below marking **A**:
    - Add brake fluid for the front brake.   (p. 102)

## 13.5 Adding brake fluid for the front brake

**WARNING**

**Danger of accidents** An insufficient brake fluid level will cause the brake system to fail.

If the brake fluid level drops below the specified marking or the specified value, the brake system has a leak or the brake pads are worn down.

- Have the brake system checked and make sure that the problem has been eliminated before the vehicle is used again.

**WARNING**

**Health hazard** Brake fluid is a harmful substance.

- Keep brake fluid out of the reach of children.
- Wear suitable protective clothing and safety glasses.
- Do not allow brake fluid to come into contact with the skin, the eyes, or clothing.
- Consult a doctor immediately if brake fluid has been ingested.
- Rinse the affected area with plenty of water in the event of contact with the skin.

- Rinse eyes thoroughly with water immediately and consult a doctor if brake fluid comes into contact with the eyes.
- If brake fluid spills on to your clothing, change the clothing.



### WARNING

**Danger of accidents** Brake fluid which is too old or of the wrong type impairs the function of the brake system.

- Make sure that brake fluid for the front and rear brake is changed in accordance with the service schedule.
- Make sure that only clean, approved brake fluid from a tightly sealed container is used.



### NOTE

**Environmental hazard** Hazardous substances cause environmental damage.

- Dispose of oils, grease, filters, fuel, cleaning agents, brake fluid, etc. correctly and in accordance with the applicable regulations.



### Note

Avoid contact between brake fluid and painted parts. Brake fluid corrodes paint.

### Preparatory work

- Check that the brake pads of the front brake are secured.  
 (p. 104)

### Filling procedure

- Move the brake reservoir mounted on the handlebar to a horizontal position.
- Remove **1** screws.
- Take off cover **2** with diaphragm **3**.
- Add brake fluid up to level **A**.

Level <b>A</b> (brake fluid level below reservoir rim)	5 mm
--	------

Brake fluid DOT 4 / DOT 5.1  (p. 166)

- Position the cover with diaphragm.
- Mount and tighten the screws.

Immediately clean up any brake fluid that has overflowed or spilled with water.

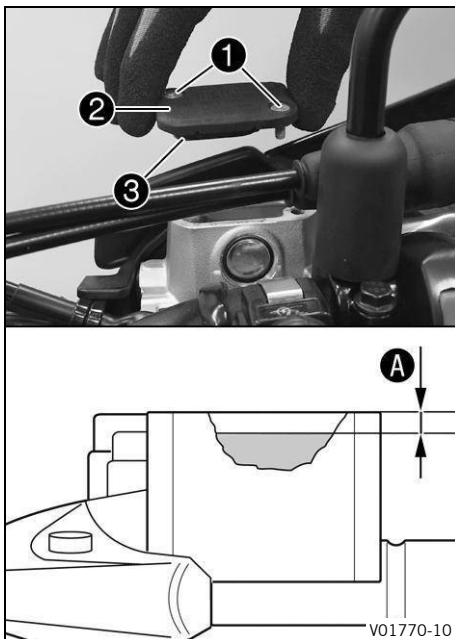

V01770-10

## 13.6 Checking that the brake pads of the front brake are secured



### WARNING

**Danger of accidents** Worn brake pads reduce the brake action.

- Make sure that worn brake pads are replaced immediately.

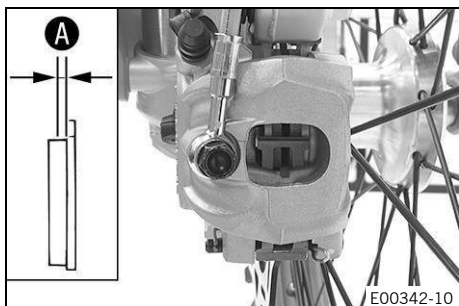

- Check all brake pads on both brake calipers for their lining thickness **A**.

Minimum pad thickness <b>A</b>	$\geq 1$ mm
--------------------------------	-------------

- » If it is less than the minimum thickness:
  - Change the front brake pads. (p. 104)
- Check the brake linings for damage and cracking.
  - » If there is damage or cracking:
    - Change the front brake pads. (p. 104)
- Check that the brake pads are secured.
  - » If the brake pads are not secured correctly:
    - Secure brake pads, replace with new parts if necessary.

## 13.7 Changing the brake pads of the front brake



### WARNING

**Danger of accidents** Incorrect servicing will cause the brake system to fail.

- Ensure that service work and repairs are performed professionally.



### WARNING

**Health hazard** Brake fluid is a harmful substance.

- Keep brake fluid out of the reach of children.
- Wear suitable protective clothing and safety glasses.
- Do not allow brake fluid to come into contact with the skin, the eyes, or clothing.
- Consult a doctor immediately if brake fluid has been ingested.
- Rinse the affected area with plenty of water in the event of contact with the skin.
- Rinse eyes thoroughly with water immediately and consult a doctor if brake fluid comes into contact with the eyes.
- If brake fluid spills on to your clothing, change the clothing.



### WARNING

**Danger of accidents** Brake fluid which is too old or of the wrong type impairs the function of the brake system.

- Make sure that brake fluid for the front and rear brake is changed in accordance with the service schedule.
- Make sure that only clean, approved brake fluid from a tightly sealed container is used.



### WARNING

**Danger of accidents** Oil, grease or wax on the brake discs reduces the brake action.

- Always keep the brake discs free of oil, fat and wax.
- Clean the brake discs with brake cleaner when necessary.



## WARNING

**Danger of accidents** Brake pads which have not been approved alter the braking action.

- Only use brake pads approved and recommended by the vehicle manufacturer.



## NOTE

**Environmental hazard** Hazardous substances cause environmental damage.

- Dispose of oils, grease, filters, fuel, cleaning agents, brake fluid, etc. correctly and in accordance with the applicable regulations.



## Note

Avoid contact between brake fluid and painted parts. Brake fluid corrodes paint.

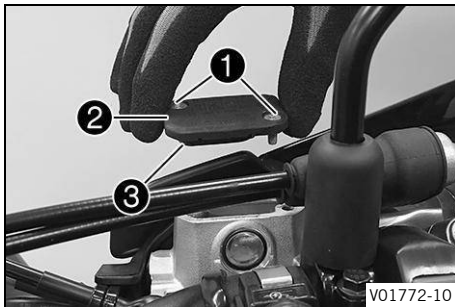

- Move the brake reservoir mounted on the handlebar to a horizontal position.
- Remove **1** screws.
- Take off cover **2** with diaphragm **3**.
- Manually press the brake caliper toward the brake disc to push back the brake pistons. Ensure that brake fluid does not flow out of the brake fluid reservoir; extract some if necessary.

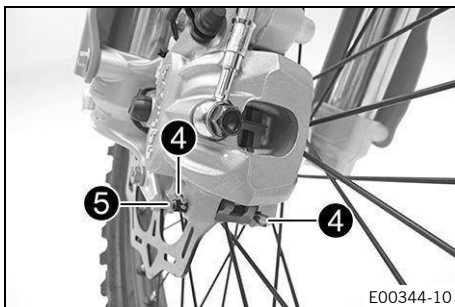

- Remove cotter pin **4**, pull out pin **5**, and remove the brake linings.
- Clean brake caliper and brake caliper support.

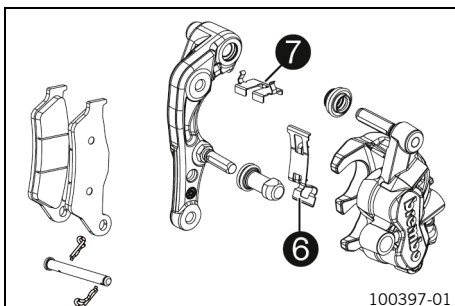

- Check that spring steel clip **6** in the brake caliper and brake pad guide plate **7** in the brake caliper support are properly seated.

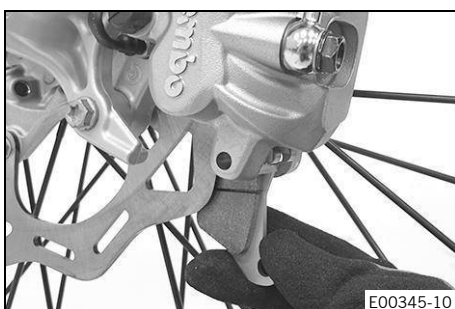

- Insert the new brake linings, insert the pin, and mount the cotter pins.



## Note

Always replace brake pads in sets.

- Operate the hand brake lever repeatedly until the brake pads are in contact with the brake disc and a pressure point is reached.

# 13 Brake system

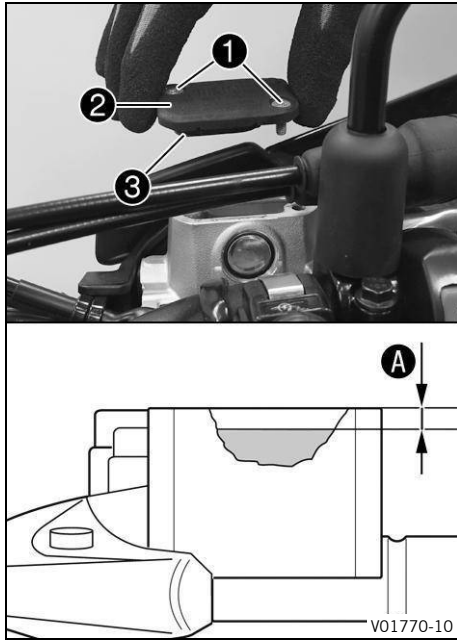

- Correct the brake fluid level to level **A**.

Level <b>A</b> (brake fluid level below reservoir rim)	5 mm
--	------

Brake fluid DOT 4 / DOT 5.1 (p. 166)

- Position cover **2** with diaphragm **3**. Mount and tighten screws **1**.

Immediately clean up any brake fluid that has overflowed or spilled with water.

## 13.8 Checking the free travel of the brake pedal



### WARNING

**Danger of accidents** The brake system fails in the event of overheating.

If there is no free travel on the brake lever, pressure builds up in the brake system.

- Set the free travel on the brake lever as specified.

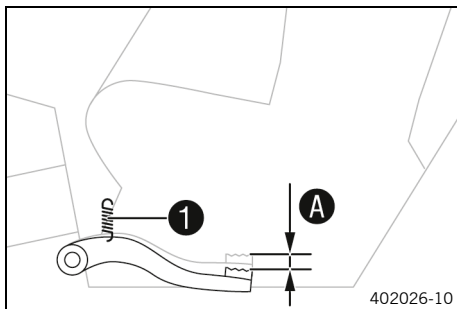

- Detach spring **1**.
- Move the brake pedal back and forth between the end stop and the brake pedal cylinder piston actuation and check free travel **A**.

Free travel of brake pedal	3 mm ... 5 mm
----------------------------	---------------

- » If the free travel does not meet the specifications:
  - Adjust the basic position of the brake pedal. (p. 106)
- Attach spring **1**.

## 13.9 Adjusting the basic position of the brake pedal



### WARNING

**Danger of accidents** The brake system fails in the event of overheating.

If there is no free travel on the brake lever, pressure builds up in the brake system.

- Set the free travel on the brake lever as specified.

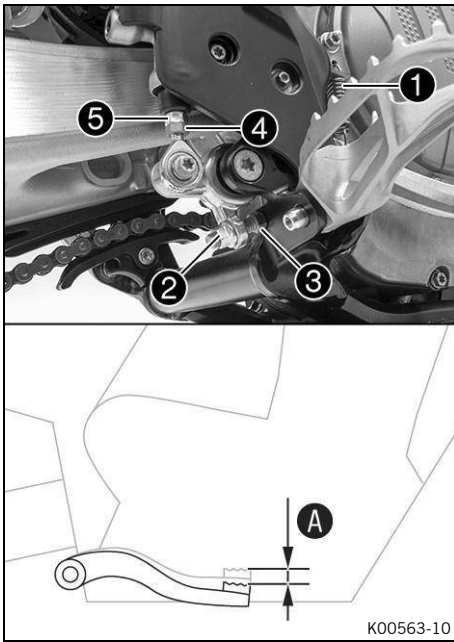

- Detach spring ①.
- Loosen nut ④ and unscrew it with push rod ⑤ until you have maximum free travel.
- To adjust the basic position of the brake pedal to individual requirements, loosen nut ② and turn screw ③ accordingly.



### Note

The range of adjustment is limited.

- Turn push rod ⑤ accordingly until you have free travel A. If necessary, adjust the basic position of the brake pedal.

Free travel of brake pedal	3 mm ... 5 mm
----------------------------	---------------

- Hold screw ③ and tighten nut ②.

Nut, brake pedal stop	
M8	20 Nm

- Hold push rod ⑤ and tighten nut ④.

Remaining nuts on chassis	
M6	10 Nm

- Attach spring ①.



## 13.10 Checking the brake fluid level for the rear brake



### WARNING

**Danger of accidents** An insufficient brake fluid level will cause the brake system to fail.

If the brake fluid level drops below the specified marking or the specified value, the brake system has a leak or the brake pads are worn down.

- Have the brake system checked and make sure that the problem has been eliminated before the vehicle is used again.

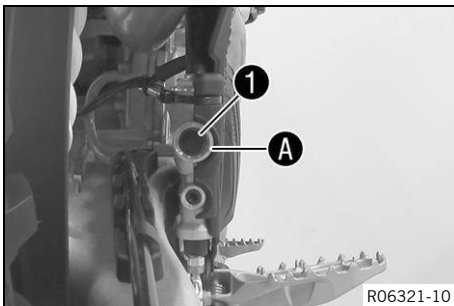

- Stand the vehicle upright.
- Check the brake fluid level in sight glass ①.
  - » If the brake fluid level has fallen below marking A:
    - Add brake fluid for the rear brake. (p. 107)



## 13.11 Adding brake fluid for the rear brake



### WARNING

**Danger of accidents** An insufficient brake fluid level will cause the brake system to fail.

If the brake fluid level drops below the specified marking or the specified value, the brake system has a leak or the brake pads are worn down.

- Have the brake system checked and make sure that the problem has been eliminated before the vehicle is used again.



## WARNING

**Health hazard** Brake fluid is a harmful substance.

- Keep brake fluid out of the reach of children.
- Wear suitable protective clothing and safety glasses.
- Do not allow brake fluid to come into contact with the skin, the eyes, or clothing.
- Consult a doctor immediately if brake fluid has been ingested.
- Rinse the affected area with plenty of water in the event of contact with the skin.
- Rinse eyes thoroughly with water immediately and consult a doctor if brake fluid comes into contact with the eyes.
- If brake fluid spills on to your clothing, change the clothing.



## WARNING

**Danger of accidents** Brake fluid which is too old or of the wrong type impairs the function of the brake system.

- Make sure that brake fluid for the front and rear brake is changed in accordance with the service schedule.
- Make sure that only clean, approved brake fluid from a tightly sealed container is used.



## NOTE

**Environmental hazard** Hazardous substances cause environmental damage.



- Dispose of oils, grease, filters, fuel, cleaning agents, brake fluid, etc. correctly and in accordance with the applicable regulations.



## Note

Avoid contact between brake fluid and painted parts. Brake fluid corrodes paint.

### Preparatory work

- Check that the brake pads of the rear brake are secured.  (p. 109)
- Remove the frame protector.  (p. 67)

### Filling procedure

- Cover the painted parts.
- Remove screw cap **1** with the membrane and the O-ring.

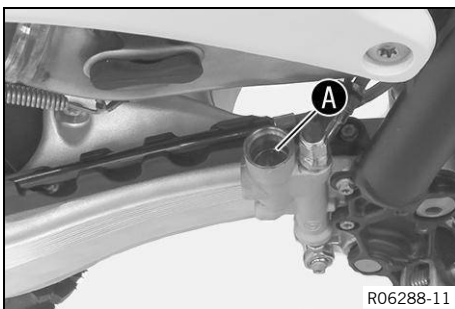
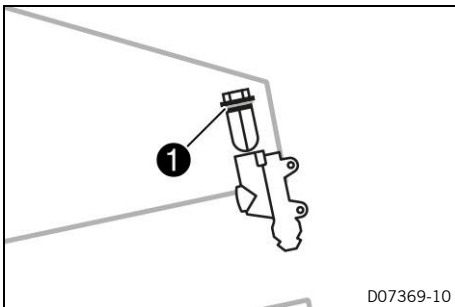

- Stand the vehicle upright.
- Add brake fluid to mark **A**.

Brake fluid DOT 4 / DOT 5.1  (p. 166)

- Mount and tighten the screw cap with the membrane and O-ring.

Immediately clean up any brake fluid that has overflowed or spilled using water.

## Reworking

- Install the frame protector.  (p. 67)



### 13.12 Checking that the brake pads of the rear brake are secured



#### WARNING



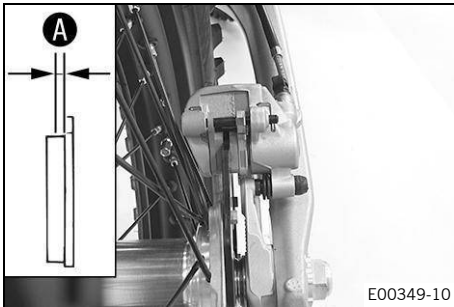

**Danger of accidents** Worn brake pads reduce the brake action.

- Make sure that worn brake pads are replaced immediately.



- Check all brake pads on both brake calipers for their lining thickness **A**.

Minimum pad thickness <b>A</b>	$\geq 1 \text{ mm}$
--------------------------------	---------------------

- » If it is less than the minimum thickness:
  - Change the rear brake pads.   (p. 109)
- Check the brake linings for damage and cracking.
  - » If there is damage or cracking:
    - Change the rear brake pads.   (p. 109)
- Check that the brake pads are secured.
  - » If the brake pads are not secured correctly:
    - Secure brake pads, replace with new parts if necessary.



### 13.13 Changing the rear brake pads



#### WARNING

**Danger of accidents** Incorrect servicing will cause the brake system to fail.

- Ensure that service work and repairs are performed professionally.



#### WARNING

**Health hazard** Brake fluid is a harmful substance.

- Keep brake fluid out of the reach of children.
- Wear suitable protective clothing and safety glasses.
- Do not allow brake fluid to come into contact with the skin, the eyes, or clothing.
- Consult a doctor immediately if brake fluid has been ingested.
- Rinse the affected area with plenty of water in the event of contact with the skin.
- Rinse eyes thoroughly with water immediately and consult a doctor if brake fluid comes into contact with the eyes.
- If brake fluid spills on to your clothing, change the clothing.



#### WARNING

**Danger of accidents** Brake fluid which is too old or of the wrong type impairs the function of the brake system.

- Make sure that brake fluid for the front and rear brake is changed in accordance with the service schedule.
- Make sure that only clean, approved brake fluid from a tightly sealed container is used.



## WARNING

- Danger of accidents** Oil, grease or wax on the brake discs reduces the brake action.
- Always keep the brake discs free of oil, fat and wax.
  - Clean the brake discs with brake cleaner when necessary.



## WARNING

- Danger of accidents** Brake pads which have not been approved alter the braking action.
- Only use brake pads approved and recommended by the vehicle manufacturer.



## NOTE

**Environmental hazard** Hazardous substances cause environmental damage.

- Dispose of oils, grease, filters, fuel, cleaning agents, brake fluid, etc. correctly and in accordance with the applicable regulations.



## Note

Avoid contact between brake fluid and painted parts. Brake fluid corrodes paint.

### Preparatory work

- Remove the frame protector.  (p. 67)

### Replacement process

- Cover the painted parts.
- Remove screw cap **1** with the membrane and the O-ring.
- Press the brake piston back to its basic position and make sure that no brake fluid overflows from the brake reservoir, extract some brake fluid if necessary.

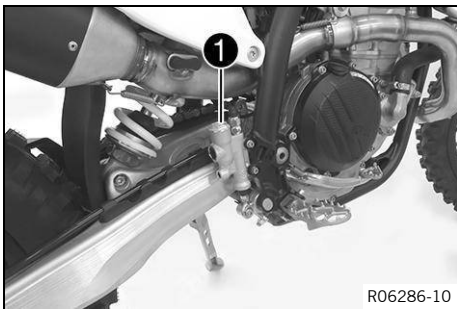

- Remove cotter pin **2**, pull out pin **3**, and remove the brake linings.
- Clean brake caliper and brake caliper support.

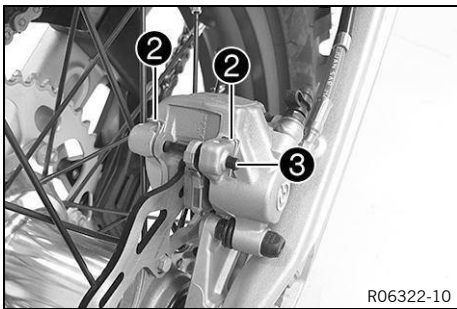

- Check that spring steel clip **4** in the brake caliper and brake pad guide plate **5** in the brake caliper support are properly seated.

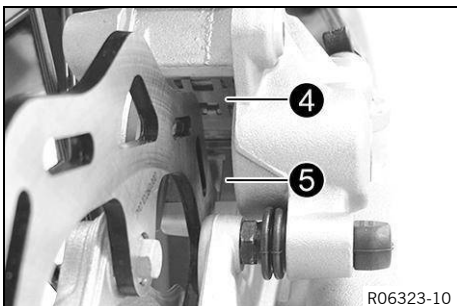

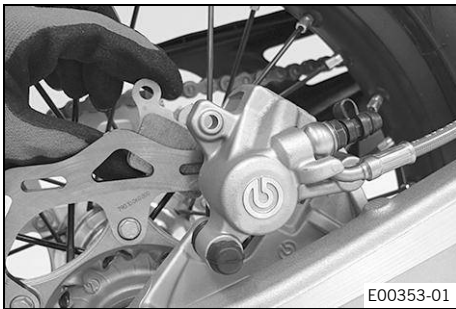

- Insert the new brake linings, insert the pin, and mount the cotter pins.
- Actuate the brake disc repeatedly until the brake pads are in contact with the brake disc and a pressure point is achieved.

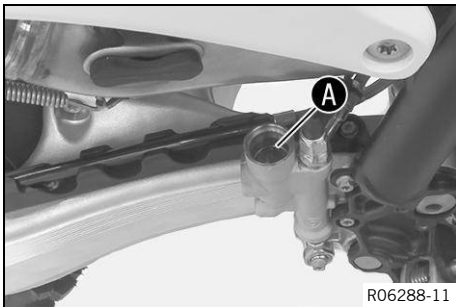

- Correct the brake fluid level to mark **A**.

Brake fluid DOT 4 / DOT 5.1  (p. 166)

- Mount and tighten screw cap **1** with the membrane and O-ring.

Immediately clean up any brake fluid that has overflowed or spilled with water.

### Reworking

- Install the frame protector.  (p. 67)



## 14.1 Removing the front wheel

### Preparatory work

- Raise the motorcycle with a lift stand.  (p. 65)

### Removal process

- Manually press the brake caliper toward the brake disc to push back the brake pistons.

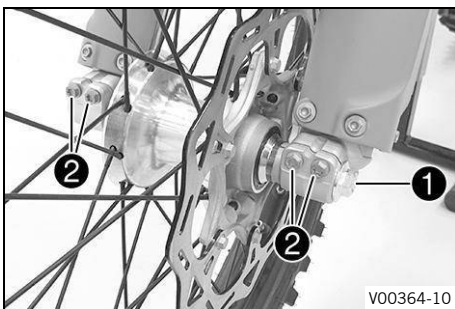

- Loosen screw **1** by four turns.
- Loosen screws **2**.
- Press on screw **1** to push the wheel spindle out of the fork shoe.
- Remove screw **1**.

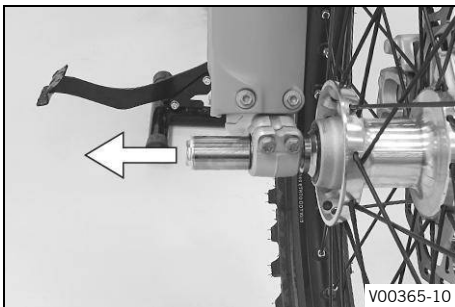

 **WARNING**  
**Danger of accidents** Damaged brake discs reduce the braking action.

- Always lay the wheel down in such a way that the brake disc is not damaged.

- Hold front wheel and remove wheel spindle. Take the front wheel out of the fork.

Do not actuate the hand brake lever when the front wheel is removed.

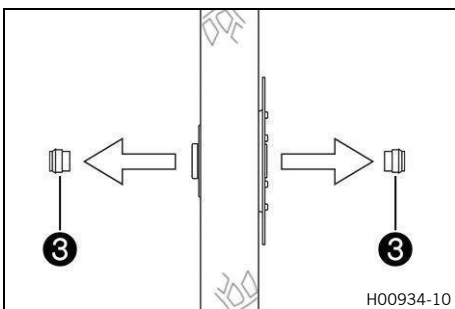

- Remove spacers **3**.

14.2 Installing the front wheel 





**WARNING**

**Danger of accidents** Oil, grease or wax on the brake discs reduces the brake action.

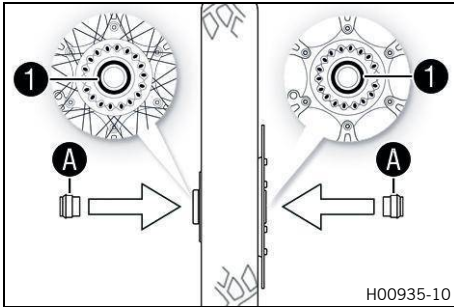
- Always keep the brake discs free of oil, fat and wax.
- Clean the brake discs with brake cleaner when necessary.



- Check the wheel bearing for damage and wear.
  - » If the wheel bearing is damaged or worn:
    - Change the front wheel bearing. 
- Clean and grease radial shaft seal 1 and contact surfaces A on the spacers.

Long-life grease  (p. 165)
---

- Insert spacers.
- Clean and lightly grease the wheel spindle.

Long-life grease  (p. 165)
---

- Position the front wheel and insert the wheel spindle.
  - ✓ The brake pads are positioned correctly.

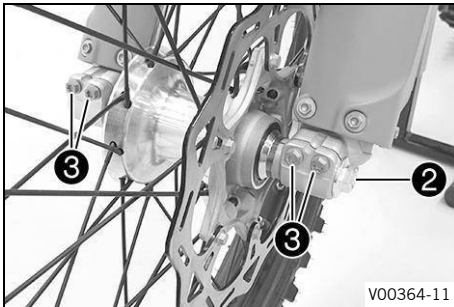

- Mount and tighten screw 2.

Screw, wheel spindle, front	
M20×1.5	35 Nm

- Operate the hand brake lever several times until the brake pads are in contact with the brake disc.
- Remove the motorcycle from the lift stand.  (p. 65)
- Operate the front brake and compress the fork a few times firmly.
  - ✓ The fork legs straighten.
- Tighten screws 3.

Screw, fork shoe	
M8	15 Nm

14.3 Removing the rear wheel 

**Preparatory work**

- Raise the motorcycle with a lift stand.  (p. 65)

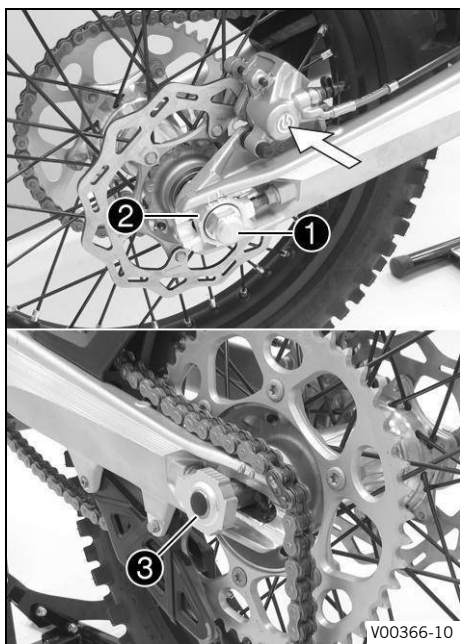

## Removal process

- Manually press the brake caliper toward the brake disc to push back the brake pistons.
- Remove nut ①.
- Remove chain tension adjuster ②. Pull out wheel spindle ③ far enough to allow the rear wheel to be pushed forward.
- Push the rear wheel forward as far as possible. Remove the chain from the rear sprocket.

Protect the components against damage by covering them.



### WARNING

**Danger of accidents** Damaged brake discs reduce the braking action.

- Always lay the wheel down in such a way that the brake disc is not damaged.

- Hold the rear wheel and remove wheel spindle. Take the rear wheel out of the swingarm.

Do not actuate the brake pedal when the rear wheel is removed.

- Remove spacers ④.

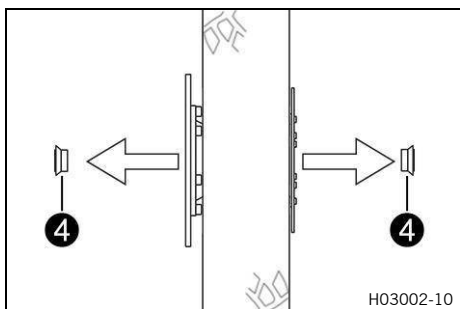

## 14.4 Installing the rear wheel



### WARNING

**Danger of accidents** Oil, grease or wax on the brake discs reduces the brake action.

- Always keep the brake discs free of oil, fat and wax.
- Clean the brake discs with brake cleaner when necessary.

### Installation procedure

- Check the wheel bearing for damage and wear.
  - » If the wheel bearing is damaged or worn:
    - Change the rear wheel bearing.
- Clean and grease radial shaft seal ① and contact surfaces A on the spacers.

Long-life grease (p. 165)

- Insert spacers.

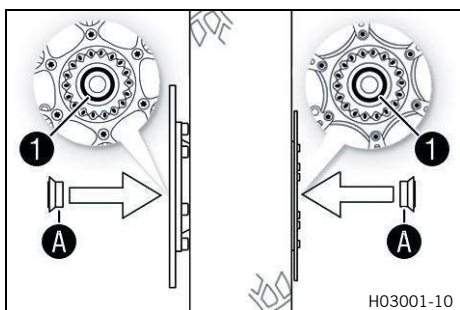

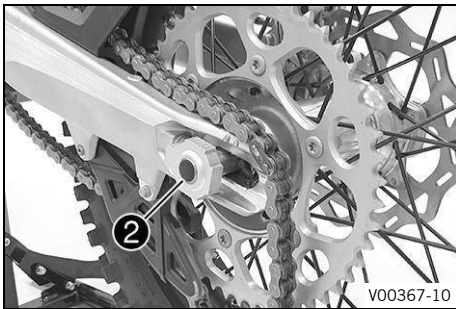

- Clean and lightly grease the wheel spindle.

Long-life grease (p. 165)

- Position the rear wheel and insert wheel spindle 2.
- ✓ The brake pads are positioned correctly.
- Attach the chain.



- Position chain tension adjuster 3. Mount nut 4 but do not tighten yet.
- Make sure that chain tension adjusters 3 are fitted correctly on adjusting screws 5.
- Check the chain tension. (p. 90)
- Tighten nut 4.

Nut, wheel spindle, rear

M22

80 Nm



### Note

The wide adjustment range of the chain adjusters enables different secondary ratios with the same chain length.

Chain tension adjusters 3 can be turned by 180°.

- Actuate the brake disc repeatedly until the brake pads are in contact with the brake disc and a pressure point is achieved.

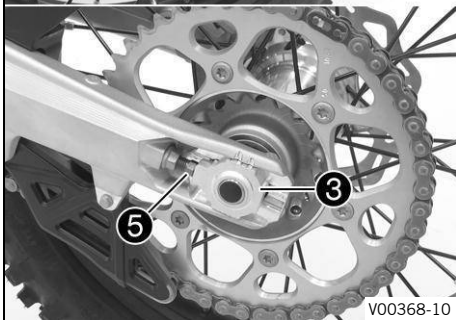

### Reworking

- Remove the motorcycle from the lift stand. (p. 65)



## 14.5 Checking the tire condition



### Note

Only mount tires approved and/or recommended by KTM.

Other tires could have a negative effect on handling characteristics.

The type, condition, and pressure of the tires all have a major impact on the handling of the motorcycle.

The tires mounted on the front and rear wheels must have a similar profile.

Worn tires have a negative effect on handling characteristics, especially on wet surfaces.

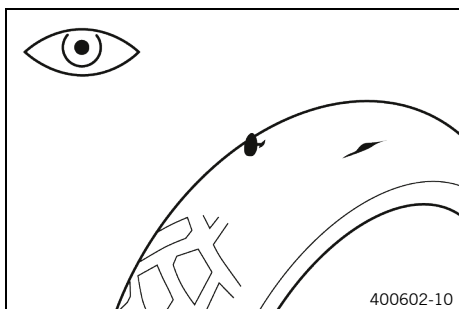

- Check the front and rear tires for cuts, embedded objects, and other damage.
  - » If the tires have cuts, run-in objects, or other damage:
    - Change the tires. 🛠️
- Check the tread depth.

Minimum tread depth	≥ 2 mm
---------------------	--------

**i Note**  
Observe the minimum tread depth required by national law.

- » If the tread depth is less than the minimum tread depth:
  - Change the tires. 🛠️

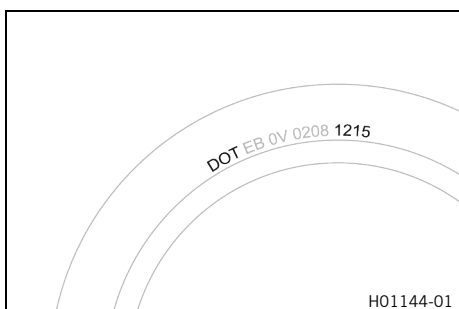

- Check the tire age.

**i Note**  
The tire date of manufacture is usually contained in the tire label and is indicated by the last four digits of the **DOT** number. The first two digits indicate the week of manufacture and the last two digits the year of manufacture.

KTM recommends that the tires be changed after 5 years at the latest, regardless of the actual state of wear.

- » If the tires are older than five years:
  - Change the tires. 🛠️

## 14.6 Checking the tire pressure

**i Note**  
Low tire pressure leads to abnormal wear and the tire overheating.  
Correct tire pressure ensures optimal riding comfort and maximum tire service life.

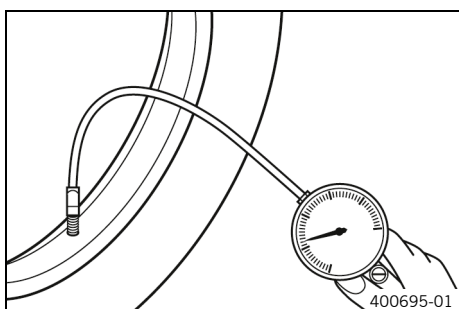

- Remove the protection cap.
- Check the tire pressure when the tires are cold.

Off-road tire pressure	
front	1.0 bar
rear	1.0 bar

Street tire pressure	
front	2.0 bar
rear	2.0 bar

- » If the tire pressure does not meet specifications:
  - Correct the tire air pressure.
- Mount the protection cap.

14.7 Checking the spoke tension



**WARNING**

**Danger of accidents** Incorrectly tensioned spokes impair the handling characteristic and can result in secondary damage.

If the spokes are too tight, they can break due to being overloaded.

Loose spokes can cause lateral or radial run-out in the wheel and other spokes will loosen as a result.

- Check the spoke tension regularly, especially on a new vehicle.

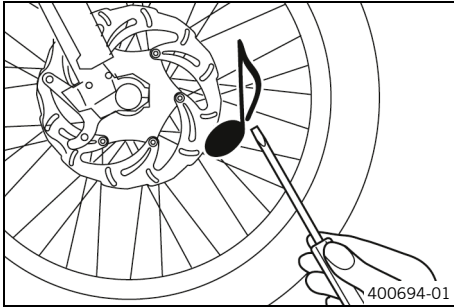

- Briefly tap each spoke with a screwdriver.

You should hear a high-pitched sound.



**Note**

The frequency of the sound depends on the spoke length and spoke diameter.

If you hear different pitches on different spokes of equal length and diameter, this is an indication of different spoke tensions.

- » If the spoke tension differs:
  - Correct the spoke tension.

- Check the spoke torque.

Spoke nipple, front wheel	
M4,5	6 Nm
Spoke nipple, rear wheel	
M4,5	6 Nm
Torque wrench kit (58429094000)	



## 15.1 Removing the 12 V battery



### NOTE

**Environmental hazard** 12-V batteries contain environmentally-hazardous materials.

- Do not dispose of 12-V batteries as household waste.
- Dispose of 12-V batteries at a collection point for used batteries.





### NOTE

**Environmental hazard** Hazardous substances cause environmental damage.

- Dispose of oils, grease, filters, fuel, cleaning agents, brake fluid, etc. correctly and in accordance with the applicable regulations.

### Preparatory work

- Remove the seat.  (p. 78)
- Remove the fuel tank.   (p. 85)

### Removal process

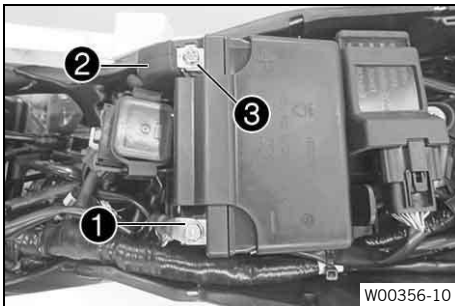

### WARNING

**Risk of injury** 12-V batteries contain harmful substances.

- Keep 12-V batteries out of the reach of children.
- Keep the battery away from sparks or open flames.
- Only charge batteries in well-ventilated rooms.
- Maintain a minimum distance from flammable materials when charging 12-V batteries.

Minimum distance	1 m
------------------	-----

- Do not charge deeply discharged 12-V batteries if the charge is already below the minimum voltage.

Minimum voltage before starting charging	9 V
--	-----

- Dispose of 12 V batteries correctly if they have less than the minimum voltage.

- Disconnect negative cable **1** from the 12 V battery.
- Pull back positive terminal cover **2** and disconnect positive cable **3** from the 12-V battery.
- Remove screw **4**.



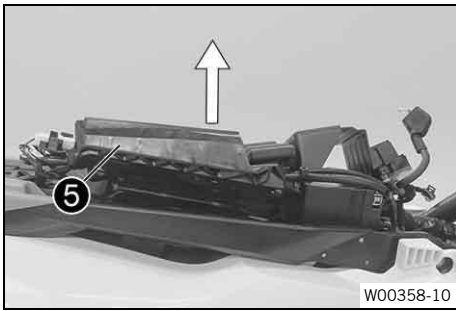

- Pull up battery holding bracket **5** and remove the 12-V battery to the rear.

Pay attention to the wiring harness.
--------------------------------------

## 15.2 Installing the 12 V battery

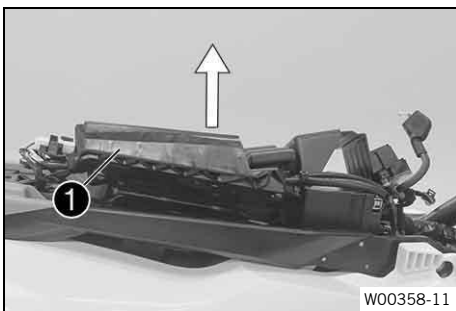

### Installation procedure

- Pull up battery holding bracket **1**, insert the 12-V battery into the battery compartment with the terminals facing upward and secure with battery holding bracket **1**.

Ensure that the cable is routed correctly.
--

12-V battery (HJTZ5S-FP-C)
----------------------------

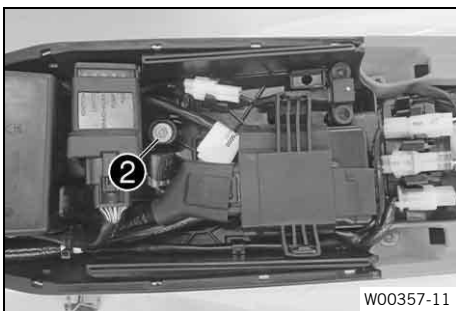

- Mount and tighten screw **2**.

Screw, battery holding bracket	
M6	6 Nm

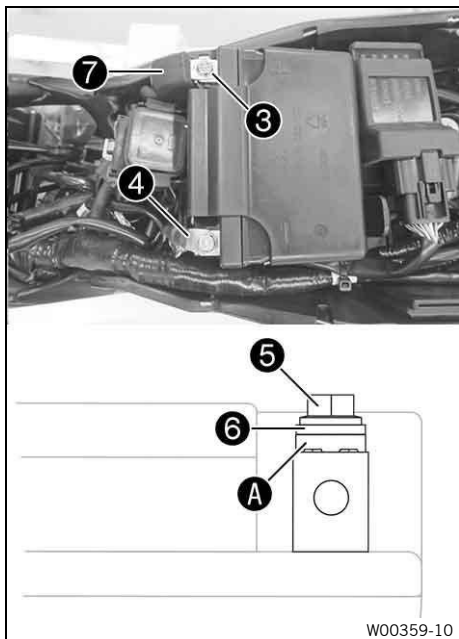

- Connect positive cable ③ to the 12 V battery.

Screw, battery terminal	
-------------------------	--

M5	2.5 Nm
----	--------

- Connect negative cable ④ to the 12 V battery.

Screw, battery terminal	
-------------------------	--

M5	2.5 Nm
----	--------

Contact disks A must be mounted under screws ⑤ and cable lug ⑥ with the claws toward the battery terminal.
--

- Slide positive terminal cover ⑦ over the positive terminal.

### Reworking

- Install the fuel tank. (p. 87)
- Mount the seat. (p. 78)

## 15.3 Charging the 12 V battery



### NOTE

**Environmental hazard** 12-V batteries contain environmentally-hazardous materials.

- Do not dispose of 12-V batteries as household waste.
- Dispose of 12-V batteries at a collection point for used batteries.



### NOTE

**Environmental hazard** Hazardous substances cause environmental damage.

- Dispose of oils, grease, filters, fuel, cleaning agents, brake fluid, etc. correctly and in accordance with the applicable regulations.



### Note

Even when there is no load on the 12 V battery, it discharges steadily each day.

The state of charge and the method of charging are very important for the service life of the 12 V battery. Rapid recharging with a high charging current shortens the service life of the battery.

If the charging current, charging voltage, or charging time is exceeded, the 12 V battery will be destroyed.

If the 12 V battery is depleted from starting the vehicle repeatedly, the battery must be charged immediately.

If the 12 V battery is left in a discharged state for an extended period, it will become deeply discharged and suffer a loss of capacity, destroying the battery.

**Preparatory work**

- Remove the seat. 📖 (p. 78)
- Remove the fuel tank. 🛠️📖 (p. 85)
- Remove the 12 V battery. 🛠️📖 (p. 118)

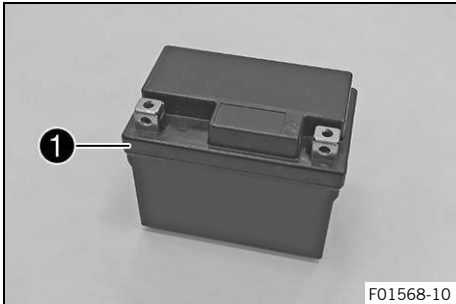

**Filling procedure**



**WARNING**

**Risk of injury** 12-V batteries contain harmful substances.

- Keep 12-V batteries out of the reach of children.
- Keep the battery away from sparks or open flames.
- Only charge batteries in well-ventilated rooms.
- Maintain a minimum distance from flammable materials when charging 12-V batteries.

Minimum distance	1 m
------------------	-----

- Do not charge deeply discharged 12-V batteries if the charge is already below the minimum voltage.

Minimum voltage before starting charging	9 V
--	-----

- Dispose of 12 V batteries correctly if they have less than the minimum voltage.

- Check the battery voltage.
  - » Battery voltage:
    - < 9 V
      - Do not charge the 12 V battery.
      - Replace the 12 V battery and dispose of the old 12 V battery properly.
    - » If the specifications have been met:
 

Battery voltage:

      - ≥ 9 V
  - Connect a charger to the 12 V battery. Switch the charger on.

Maximum charging voltage	14.4 V
Minimum charging voltage	3.0 A
Maximum charging time	12 h
Recharge the 12 V battery regularly when the motorcycle is not being used.	6 months
Ideal charging and storage temperature of the lithium-ion battery	10 °C ... 20 °C

## Battery charger (79629974000)



### Note

If the charging current, charging voltage, or charging time is exceeded, the 12-V battery will be destroyed.

If the 12 V battery is left in a discharged state for an extended period, it will become deeply discharged and suffer a loss of capacity, destroying the battery.

The 12 V battery is maintenance-free.

Never remove cover .



### Note

This battery charger tests whether the 12-V battery retains its voltage. It is also impossible to overcharge the 12-V battery with this battery charger. The charging time may be longer at low temperatures.



### Note

This battery charger is only suitable for lithium iron phosphate batteries. Read the accompanying **KTM PowerParts** instructions.

- Switch off the charger after charging and disconnect from the 12-V battery.

### Reworking

- Install the 12 V battery. (p. 119)
- Install the fuel tank. (p. 87)
- Mount the seat. (p. 78)

## 15.4 Changing the main fuse



### WARNING

**Fire hazard** Incorrect fuses overload the electrical system.

- Use only fuses with the prescribed amperage.
- Do not bypass or repair fuses.



### Note

The main fuse protects all electrical power loads of the vehicle. It is located in the starter relay housing under the seat.

### Preparatory work

- Remove the seat. (p. 78)
- Remove the fuel tank. (p. 85)

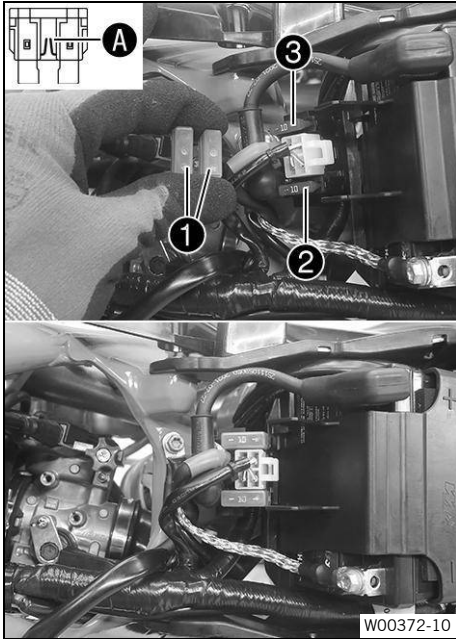

**Replacement process**

- Remove protection caps ①.
- Remove faulty main fuse ②.



**Note**

A faulty fuse has a burned-out fuse wire **A**.  
A spare fuse ③ is located in the starter relay.

- Insert the main fuse.

Fuse (58011109120)

- Check that the electrical equipment is functioning properly.



**Tip**

Insert a new spare fuse so that it is available if needed.

- Mount the protection caps.
- Mount the starter relay onto the holder and route the cable.

**Reworking**

- Install the fuel tank. 🛠️📖 (p. 87)
- Mount the seat. 📖 (p. 78)

**15.5 Removing the headlight mask with the headlight**



- Loosen screws ①.
- Slide the headlight mask up and swing it forward.
- Detach the brake line and wiring harness from the headlight mask.

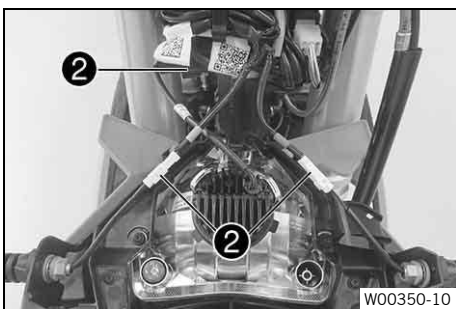

- Detach plug-in connectors ② and take off the headlight mask with the headlight.

## 15.6 Installing the headlight mask with the headlight

### Installation procedure

- Join plug-in connectors ❶.

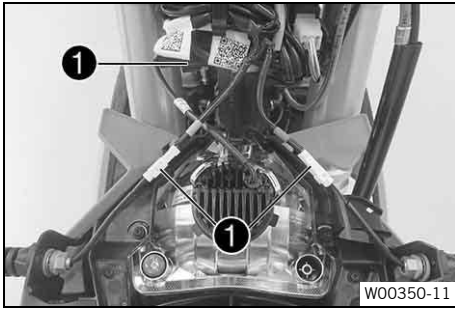

- Position the brake line and wiring harness in the brake line guide.
- Position the headlight mask.
  - ✓ The holding lugs engage in the fender.
- Mount and tighten screws ❷.

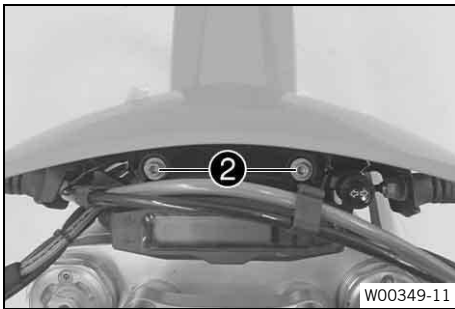

Remaining screws on chassis	
M6	10 Nm

### Reworking

- Check the headlight setting. 📖 (p. 125)

## 15.7 Changing the headlight bulb

### Preparatory work

- Remove the headlight mask with the headlight. 📖 (p. 123)

### Replacement process

- Turn LED unit ❶ counterclockwise all the way and take it out of the reflector.

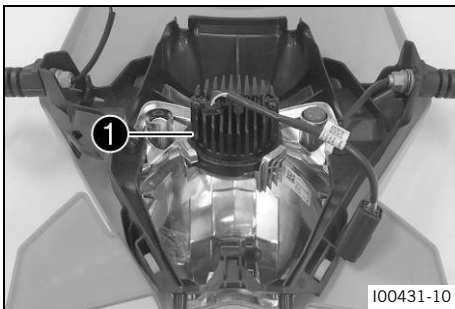

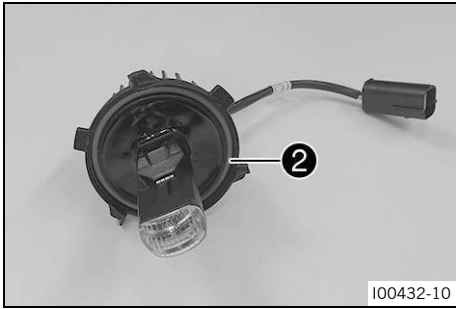

- Insert the LED unit into the reflector and turn it clockwise all the way.

Ensure that O-ring ② is seated properly.
Low beam (LED)

**Reworking**

- Install the headlight mask with the headlight. 📖 (p. 124)
- Check the headlight setting. 📖 (p. 125)

**15.8 Checking the headlight setting**

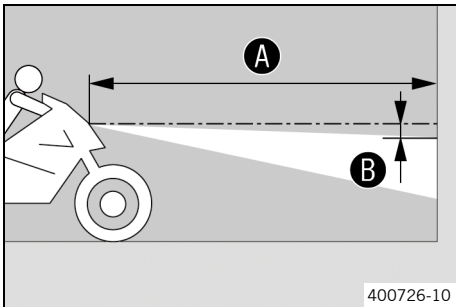

- Park the vehicle on a horizontal surface in front of a light-colored wall and make a mark at the height of the center of the low beam headlight.
- Make another mark at a distance ⑤ under the first marking.

Distance ⑤	5 cm
------------	------

- Position the vehicle vertically at a distance ④ away from the wall.

Distance ④	5 m
------------	-----

- Sit on the motorcycle.
- Switch on the low beam.
- Check the headlight setting.

The boundary between light and dark must be exactly on the lower mark for a motorcycle with rider.
--

- » If the boundary between light and dark does not meet specifications:
  - Adjust headlight range. 📖 (p. 125)
- » If the boundary between light and dark does not meet specifications:
  - Adjust headlight range. 📖 (p. 125)

**15.9 Adjusting the headlight range**

**Preparatory work**

- Check the headlight setting. 📖 (p. 125)

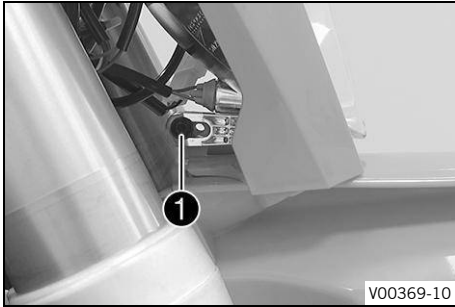

### Adjustment procedure

- Loosen screw ①.
- Adjust the headlight range by pivoting the headlight.

The boundary between light and dark must be exactly on the lower mark for a motorcycle with rider (instructions on how to apply the mark: Checking the headlight setting).



#### Note

A change in weight may require a correction of the headlight range.

- Tighten screw ①.

## 15.10 Changing the turn signal bulb



### NOTE

**Impairments to reflectors and lamps** Grease on the reflector reduces the emitted light.

Grease on the bulb will evaporate due to the heat and be deposited on the reflector.

Grease residue on the bulb reduces heat dissipation and increases the heat of the bulb, thus reducing its service life.

- Clean and degrease the bulbs before mounting.
- Do not touch the bulbs with your bare hands.

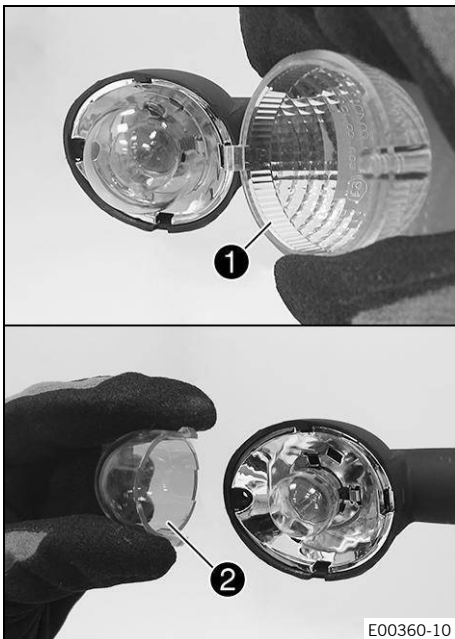

### Replacement process

- Remove the screw on the rear of the turn signal housing.
- Carefully remove turn signal glass ①.
- Lightly squeeze orange cap ② in the area of the holding lugs and take it off.
- Press the turn signal bulb lightly into the socket, turn it counterclockwise by about 30°, and pull it out of the socket.
- Press the new turn signal bulb carefully into the socket and turn it clockwise until it stops.

Turn signal (R10W / Socket BA15s)

- Mount the orange cap.
- Position the turn signal glass.
- Insert the screw and first turn counterclockwise until it engages in the thread with a small jerk. Tighten the screw lightly.

### Reworking

- Check that the turn signal system is functioning properly.

15.11 combination instrument battery, changing

**Preparatory work**

- Remove the headlight mask with the headlight. 📖 (p. 123)

**Replacement process**

- Remove screws ❶ with the washers.
- Pull the combination instrument upward out of the holder.

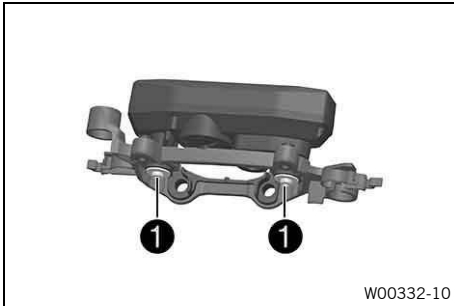

- Using a coin, turn protection cap ❷ all the way counterclockwise and take it off.
- Remove combination instrument battery ❸.
- Insert the combination instrument with the label facing upward.

Button cell (CR 2430)

- Check the O-ring of the protection cap for correct seating.

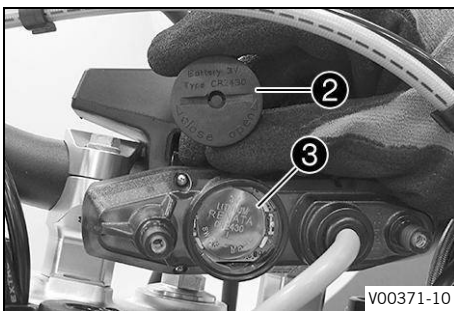

- Position protection cap ❷ and turn all the way clockwise using a coin.
- Press any button on the combination instrument.
  - ✓ The combination instrument is activated.
- Position the combination instrument in the holder.
- Mount and tighten the screws with washers.

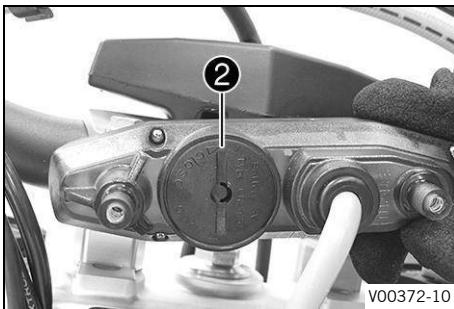

**Reworking**

- Install the headlight mask with the headlight. 📖 (p. 124)
- Check the headlight setting. 📖 (p. 125)
- Set to kilometers or miles. 📖 (p. 29)
- Set the combination instrument. 📖 (p. 30)
- Set the clock. 📖 (p. 30)



## 15.12 Diagnostic connector

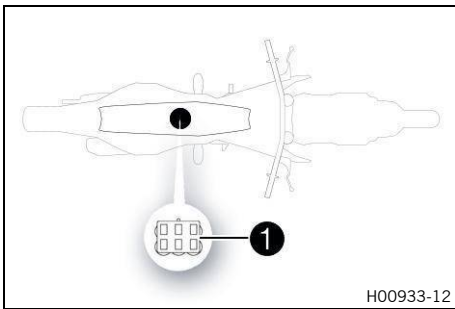

Diagnostics connector **1** is located under the seat.

## 15.13 OCU

OCU **1** is located under the seat.

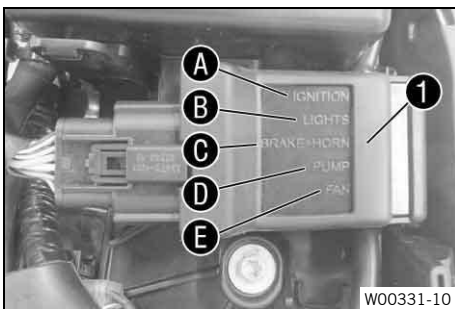

The OCU replaces the electronic fuses and relays.

All outputs are switched independently of the signals of the voltage regulator and ECU.

The outputs are deactivated individually in the event of overcurrent.

This enables easy error detection because the status of each output is indicated via LED lights.

The OCU monitors the electronics system completely independently.

As soon as an indicated error is rectified, the status light of the OCU changes from red to green.

### overview

<b>A</b>	Ignition
<b>B</b>	Light
<b>C</b>	Brake light + horn
<b>D</b>	Fuel pump
<b>E</b>	Radiator fan

## 16.1 Cooling system

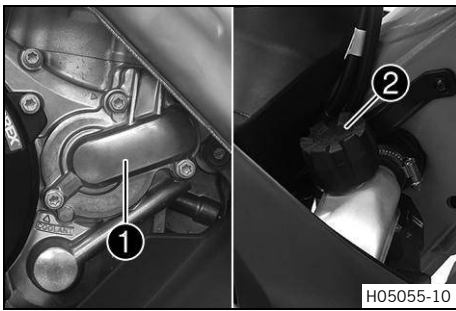

Water pump ① in the engine circulates the coolant. The pressure resulting from the warming of the cooling system is regulated by a valve in radiator cap ②. This ensures that operating the vehicle at the specified coolant temperature will not result in a risk of malfunctions.

120 °C

The coolant is cooled by the air stream.

The lower the vehicle speed, the lower the cooling effect. Dirty cooling fins also reduce the cooling effect.

**(All special models / XW-F)**

Additional cooling is provided by the radiator fan, which is activated at high temperature.

## 16.2 Checking the frost protection and coolant level



### WARNING

**Danger of scalding** The coolant heats up and is under high pressure when the vehicle is operated.

- Do not open the radiator, the radiator hoses, or other cooling system components if the engine or the cooling system are at operating temperature.
- Allow the cooling system and the engine to cool down before you open the radiator, the radiator hoses, or other components of the cooling system.
- In the event of scalding, rinse the area affected immediately with lukewarm water.



### WARNING

**Health hazard** Coolant is harmful to health.

- Keep coolant out of the reach of children.
- Do not allow coolant to come into contact with skin, eyes, or clothing.
- Consult a doctor immediately if coolant has been ingested.
- Rinse the affected area immediately with plenty of water in the event of contact with skin.
- Rinse eyes thoroughly with water and consult a doctor immediately if coolant comes into contact with eyes.
- If coolant spills on to your clothing, change the clothing.
- Store coolant properly in a suitable container and keep out of the reach of children.

Condition: The engine is cold

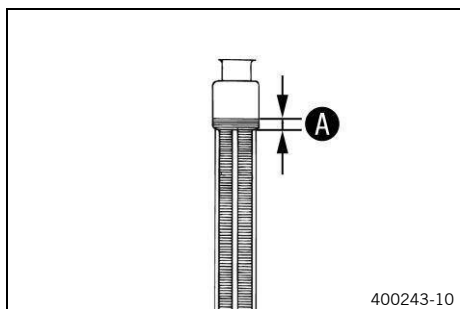

- Stand the motorcycle upright on a level surface.
- Take off the radiator cap.
- Check the frost protection in the coolant.

-45 °C ... -25 °C
-------------------

» If the frost protection in the coolant does not match the specified value:

- Correct the frost protection in the coolant.

- Check the coolant level in the radiator.

Coolant level <b>A</b> above the radiator fins	10 mm
--	-------

» If the coolant level does not meet the specifications:

- Correct the coolant level.

coolant
---------

Coolant  (p. 166)	0.95 l
Antifreeze protection to at least: -25 °C	

- Mount the radiator cap.

## 16.3 Checking the coolant level



### WARNING

**Danger of scalding** The coolant heats up and is under high pressure when the vehicle is operated.

- Do not open the radiator, the radiator hoses, or other cooling system components if the engine or the cooling system are at operating temperature.
- Allow the cooling system and the engine to cool down before you open the radiator, the radiator hoses, or other components of the cooling system.
- In the event of scalding, rinse the area affected immediately with lukewarm water.



### WARNING

**Health hazard** Coolant is harmful to health.

- Keep coolant out of the reach of children.
- Do not allow coolant to come into contact with skin, eyes, or clothing.
- Consult a doctor immediately if coolant has been ingested.
- Rinse the affected area immediately with plenty of water in the event of contact with skin.
- Rinse eyes thoroughly with water and consult a doctor immediately if coolant comes into contact with eyes.
- If coolant spills on to your clothing, change the clothing.
- Store coolant properly in a suitable container and keep out of the reach of children.

Condition: The engine is cold

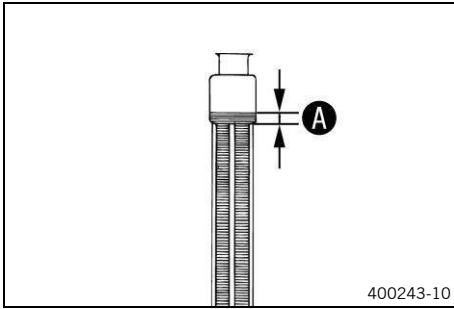

- Stand the motorcycle upright on a level surface.
- Take off the radiator cap.
- Check the coolant level in the radiator.

Coolant level <b>A</b> above the radiator fins	10 mm
--	-------

- » If the coolant level does not meet the specifications:
  - Correct the coolant level.

coolant	
Coolant  (p. 166)	0.95 l
Antifreeze protection to at least: -25 °C	

- Mount the radiator cap.



## 16.4 Draining the coolant



### WARNING

**Danger of scalding** The coolant heats up and is under high pressure when the vehicle is operated.

- Do not open the radiator, the radiator hoses, or other cooling system components if the engine or the cooling system are at operating temperature.
- Allow the cooling system and the engine to cool down before you open the radiator, the radiator hoses, or other components of the cooling system.
- In the event of scalding, rinse the area affected immediately with lukewarm water.



### WARNING

**Health hazard** Coolant is harmful to health.

- Keep coolant out of the reach of children.
- Do not allow coolant to come into contact with skin, eyes, or clothing.
- Consult a doctor immediately if coolant has been ingested.
- Rinse the affected area immediately with plenty of water in the event of contact with skin.
- Rinse eyes thoroughly with water and consult a doctor immediately if coolant comes into contact with eyes.
- If coolant spills on to your clothing, change the clothing.
- Store coolant properly in a suitable container and keep out of the reach of children.

Condition: The engine is cold

### Preparatory work

(All special models / XW-F)

- Remove the skid plate.  (p. 99)

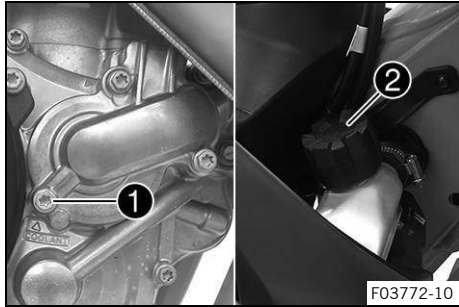

### Emptying process

- Stand the motorcycle upright.
- Place an appropriate container under the water pump cover.
- Remove screw ① and take off radiator cap ②.
- Completely drain the coolant.
- Mount screw ① with the new sealing ring and tighten.

Screw, water pump cover	
M6	10 Nm

## 16.5 Refilling the coolant



### WARNING

**Health hazard** Coolant is harmful to health.

- Keep coolant out of the reach of children.
- Do not allow coolant to come into contact with skin, eyes, or clothing.
- Consult a doctor immediately if coolant has been ingested.
- Rinse the affected area immediately with plenty of water in the event of contact with skin.
- Rinse eyes thoroughly with water and consult a doctor immediately if coolant comes into contact with eyes.
- If coolant spills on to your clothing, change the clothing.
- Store coolant properly in a suitable container and keep out of the reach of children.

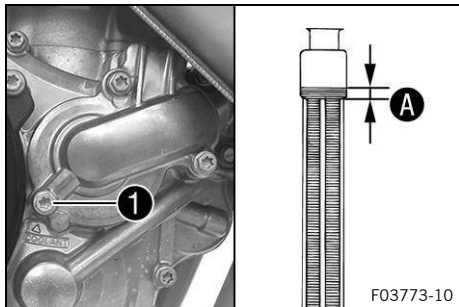

### Filling procedure

- Make sure that screw ① is tightened.
- Stand the motorcycle upright.
- Pour coolant in up to level A above the radiator fins.

10 mm	
coolant	
Coolant (p. 166) Antifreeze protection to at least: -25 °C	0.95 l

- Mount the radiator cap.

### Reworking

- Go for a short test ride.
- Check the coolant level. (p. 130)

### (All special models / XW-F)

- Install the skid plate. (p. 100)

## 16.6 Changing the coolant



### WARNING

**Danger of scalding** The coolant heats up and is under high pressure when the vehicle is operated.

- Do not open the radiator, the radiator hoses, or other cooling system components if the engine or the cooling system are at operating temperature.
- Allow the cooling system and the engine to cool down before you open the radiator, the radiator hoses, or other components of the cooling system.
- In the event of scalding, rinse the area affected immediately with lukewarm water.



### WARNING

**Health hazard** Coolant is harmful to health.

- Keep coolant out of the reach of children.
- Do not allow coolant to come into contact with skin, eyes, or clothing.
- Consult a doctor immediately if coolant has been ingested.
- Rinse the affected area immediately with plenty of water in the event of contact with skin.
- Rinse eyes thoroughly with water and consult a doctor immediately if coolant comes into contact with eyes.
- If coolant spills on to your clothing, change the clothing.
- Store coolant properly in a suitable container and keep out of the reach of children.

Condition: The engine is cold

### Preparatory work

(All special models / XW-F)

- Remove the skid plate. (p. 99)

### Replacement process

- Stand the motorcycle upright.
- Place an appropriate container under the water pump cover.
- Remove screw **1** and take off radiator cap **2**.
- Completely drain the coolant.

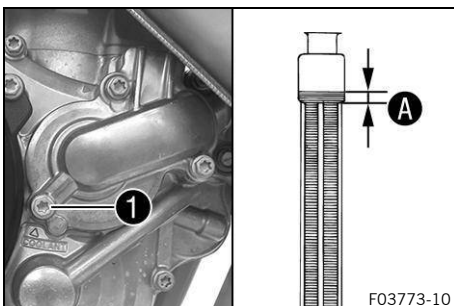

- Mount screw **1** with the new sealing ring and tighten.

Screw, water pump cover	
M6	10 Nm

- Pour coolant in up to level **A** above the radiator fins.

10 mm
-------

coolant	
Coolant  (p. 166) Antifreeze protection to at least: -25 °C	0.95 l

- Mount radiator cap **2**.

### Reworking

- Go for a short test ride.
- Check the coolant level.  (p. 130)

### (All special models / XW-F)

- Install the skid plate.  (p. 100)



## 17.1 Checking the play in the throttle cable

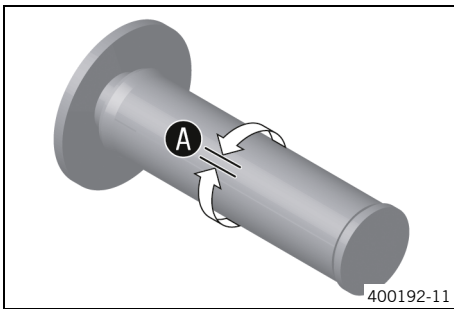

- Check the throttle grip for smooth operation.
- Move the handlebar to the straight-ahead position. Turn the throttle twist grip back and forth slightly and determine the play in throttle cable **A**.

Throttle cable play	3 mm ... 5 mm
---------------------	---------------

- » If the throttle cable play does not meet the specified value:
  - Adjust the throttle cable play. (p. 135)
- Press the cold start button in all the way to the stop.

When the throttle twist grip is turned forward, the cold start button jumps back to the start position.

- » If the cold start button does not return to its original position:
  - Adjust the throttle cable play. (p. 135)



### DANGER

**Danger of poisoning** Exhaust gases are toxic and inhaling them may result in unconsciousness and death.

- Always ensure that there is sufficient ventilation when running the engine.
- Use suitable exhaust extraction when starting or running the engine in an enclosed space.

- Start the engine and let it run at idle speed. Move the handlebar back and forth over the entire steering range.

The idle speed must not change.

- » If the idle speed changes:
  - Adjust the throttle cable play. (p. 135)

## 17.2 Adjusting the throttle cable play



### Note

If the correct routing of the throttle cables has already been secured, the fuel tank does not need to be removed.

### Preparatory work

- Remove the seat. (p. 78)
- Remove the fuel tank. (p. 85)
- Check the throttle cable routing. (p. 95)

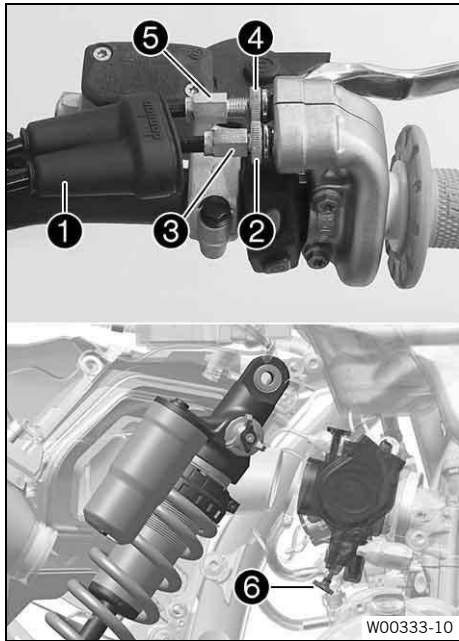

### Adjustment procedure

- Move the handlebar to the straight-ahead position.
- Push back boot ①.
- Loosen nut ②.
- Screw adjusting screw ③ in as far as possible.
- Loosen nut ④.
- Press cold start button ⑥ all the way to the stop.
- Turn adjusting screw ⑤ so that the cold start button moves to the basic position when the throttle twist grip is turned forward.
- Tighten nut ④.
- Turn adjusting screw ③ so that there is play in the throttle cable at the throttle twist grip.

Throttle cable play	3 mm ... 5 mm
---------------------	---------------

- Tighten nut ②.
- Slide on boot ①.
- Check the throttle grip for smooth operation.

### Reworking

- Check the play in the throttle cable. 📖 (p. 135)

## 17.3 Adjusting the characteristic map of the throttle response 🛠️

### **i** Note

On the throttle grip, the characteristic map of the throttle response is changed by changing the guide plate. A guide plate with a different characteristic map is supplied.

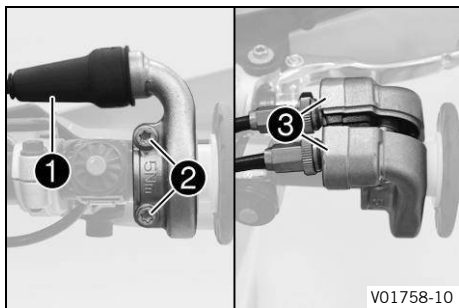

### Adjustment procedure

- Push back boot ①.
- Remove screws ② and half-shells ③.
- Detach the throttle cables and take off the grip tube.

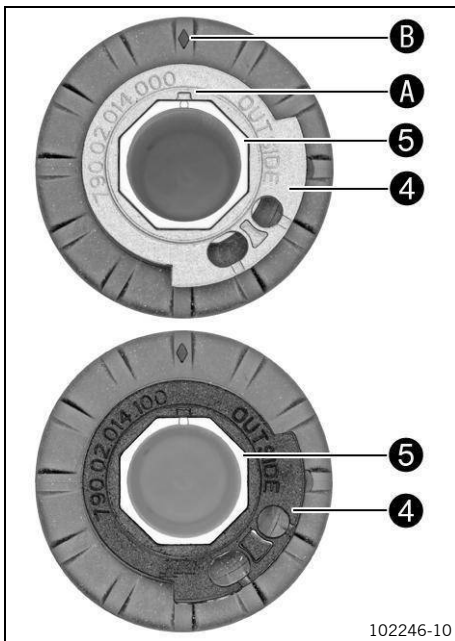

- Remove guide plate ④ from handle tube ⑤.
- Position the required guide plate on the grip tube.

The label **OUTSIDE** must be visible. Marking **A** must be positioned at marking **B**.

Gray guide plate (A48002014000)

**Work material (Alternative 1 / 1)**

Black guide plate (A46002014000)

**i Note**  
 The gray guide plate opens the throttle valve more slowly.  
 The black guide plate opens the throttle valve more quickly.  
 The gray guide plate is mounted upon delivery.

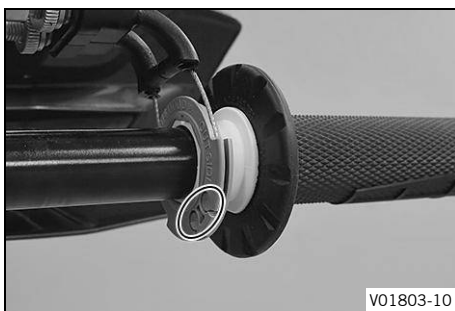

- Clean the outside of the handlebar and the inside of the grip tube. Mount the grip tube on the handlebar.
- Attach the throttle cables to the guide plate and route correctly.
- Position half-shells ③, mount and tighten screws ②.

Screw, throttle twist grip

M6	5 Nm
----	------

- Slide on sleeve ① and check the throttle grip for ease of movement.

### Reworking

- Check the play in the throttle cable. 📖 (p. 135)



## 17.4 Changing the mapping (All special models)

**i Note**  
 If the combination switch is mounted, the vehicle's road permit, if any, expires.  
 The vehicle may only be operated in closed-off areas away from public road traffic if the combination switch is installed.  
 Traction control can be activated additionally using button **TC**.  
 The mapping can also be changed during the ride.

- Select one of the following alternatives.

**Activating STANDARD mapping:**



- Press button **1**.

Engine speed	< 4,000 rpm
--------------	-------------

- ✓ Indicator light **A** lights up.
- ✓ STANDARD: balanced response

**i Note**  
Traction control can be activated additionally using TC button **3**.

### Activating **ADVANCED** mapping:

- Press button **2**.

Engine speed	< 4,000 rpm
--------------	-------------

- ✓ Indicator light **B** lights up.
- ✓ **ADVANCED**: direct response

**i Note**  
Traction control can be activated additionally using TC button **3**.

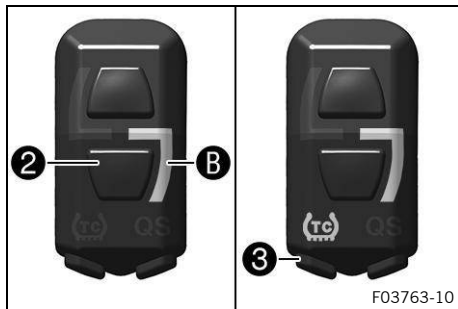

## 17.5 Adjusting the idle speed



### WARNING

- Danger of accidents** The engine may suddenly come to a halt if the idle speed is set too low.
- Set the idle speed to the specified value.

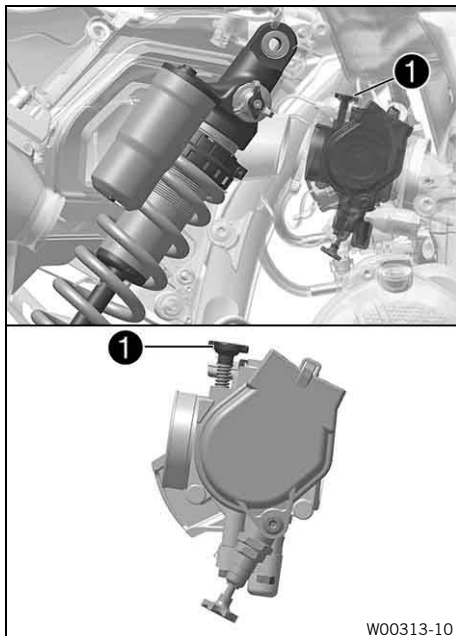

- Run the engine until warm.
- ✓ Cold start button deactivated: The cold start button is in the basic position.



### DANGER

**Danger of poisoning** Exhaust gases are toxic and inhaling them may result in unconsciousness and death.

- Always ensure that there is sufficient ventilation when running the engine.
- Use suitable exhaust extraction when starting or running the engine in an enclosed space.

- Adjust the idle speed by turning idle speed adjusting screw **1**.

Idle speed	1,950 rpm ... 2,050 rpm
------------	----------------------------

Service hour counter with revolution counter (A54012920100)
---

**i Note**  
Turning counterclockwise lowers the idle speed.  
Turning clockwise increases the idle speed.

## 17.6 Teaching the throttle valve position

- i Note** If the control unit detects that the throttle valve position at idle speed needs to be retaught, then the malfunction indicator lamp flashes 2x per second.

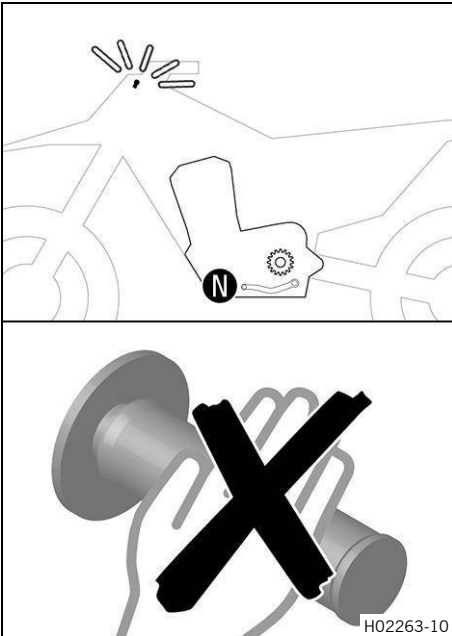

- ! DANGER**  
**Danger of poisoning** Exhaust gases are toxic and inhaling them may result in unconsciousness and death.
- Always ensure that there is sufficient ventilation when running the engine.
  - Use suitable exhaust extraction when starting or running the engine in an enclosed space.

- Allow the vehicle to run at idle speed.
- ✓ The malfunction indicator lamp stops flashing once teaching is completed.

- i Note** If the engine becomes too warm, perform a cool-down ride at medium speed. Then do not switch off the engine after this, but leave it running at idle speed until teaching is completed.

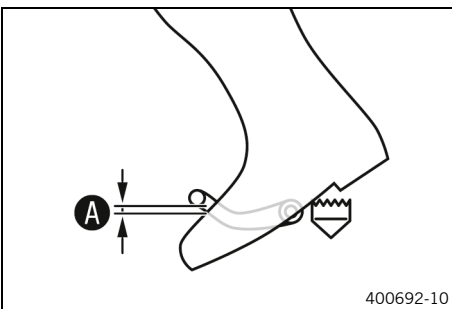

## 17.7 Checking the basic position of the gear shift lever

- i Note** When driving, the gear shift lever must not touch the rider's boot when in the basic position. When the gear shift lever keeps touching the boot, the transmission will be subject to an excessive load.



- Sit on the vehicle in the riding position and measure the distance **A** between the upper edge of your boot and the shift lever.

Distance between the gear shift lever and upper edge of boot	10 mm ... 20 mm
--	-----------------

- » If the distance does not meet the specifications:
  - Adjust the basic position of the gear shift lever. 
  -  (p. 140)

## 17.8 Adjusting the basic position of the gear shift lever

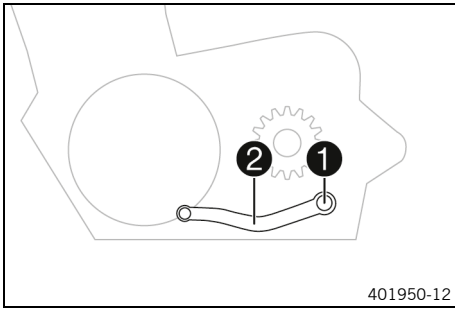

- Remove screws **1** with the washers and remove gear shift lever **2**.

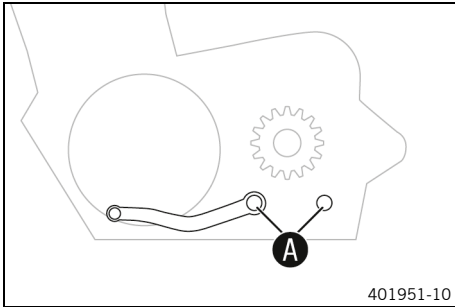

- Clean tothing **A** of the gear shift lever and shift shaft.
- Mount shift lever **2** on the shift shaft in the required position and engage the gearing.

The gear shift lever must not come into contact with any other vehicle components during the shift procedure.

**i Note**

The range of adjustment is limited.

- Mount and tighten screw **1** with the washers.

Screw, shift lever	
M6	14 Nm
<b>Loctite® 243</b>	

## 18.1 Changing the fuel screen



### DANGER

**Fire hazard** Fuel is highly flammable.

The fuel in the fuel tank expands when warm and can escape if overfilled.

- Do not refuel the vehicle in the vicinity of open flames, glowing, or smoldering objects.
- Make sure that nobody smokes in the vicinity of the vehicle during the refueling process.
- Switch off the engine for refueling.
- Make sure that no fuel is spilled; particularly not on hot parts of the vehicle.
- If any fuel is spilled, wipe it up immediately.
- Do not overfill the fuel tank.



### WARNING

**Danger of poisoning** Fuel is harmful to health.

- Do not allow fuel to come into contact with skin, eyes, or clothing.
- Consult a doctor immediately if fuel has been ingested.
- Do not inhale fuel vapors.
- Rinse the affected area immediately with plenty of water in the event of contact with skin.
- Rinse eyes thoroughly with water and consult a doctor immediately if fuel comes into contact with eyes.
- If fuel spills on to your clothing, change the clothing.
- Store fuel properly in a suitable container and keep out of the reach of children.



### NOTE

**Environmental hazard** Improper handling of fuel is dangerous to the environment.

- Do not allow fuel to enter the groundwater, the soil, or the sewage system.

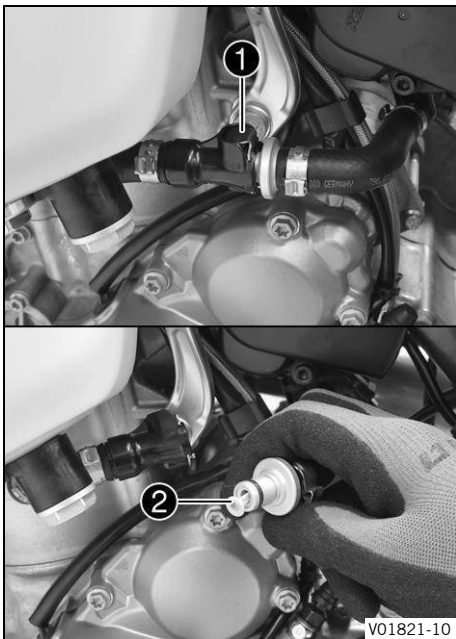

- Clean quick-lock coupling **1** thoroughly with compressed air.

Dirt must not enter into the fuel line. Dirt in the fuel line clogs the injector!

- Disconnect the quick-lock coupling.



### Note

Remaining fuel may flow out of the fuel hose.

- Pull fuel screen **2** out of the connecting piece.
- Slide the new fuel screen all the way into the connecting piece.
- Spray silicone spray onto a lint-free cleaning cloth and lightly lubricate the O-ring of the quick-lock coupling.

Silicone spray  (p. 166)

- Join quick-lock couplings.



## DANGER

**Danger of poisoning** Exhaust gases are toxic and inhaling them may result in unconsciousness and death.

- Always ensure that there is sufficient ventilation when running the engine.
- Use suitable exhaust extraction when starting or running the engine in an enclosed space.

- Start the engine and check the response.

## 18.2 Checking the engine oil level

### Preparatory work

- Stand the motorcycle upright on a level surface.

### Control process

Condition: Engine is at operating temperature

- Check the engine oil level.

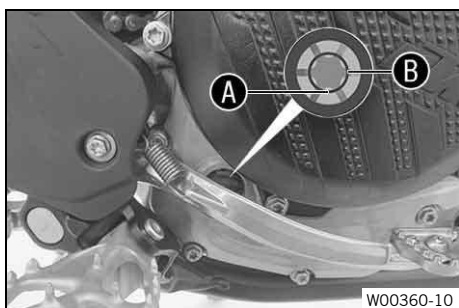

The engine oil is at a level between lower edge **A** and the middle of level viewer **B**.

After switching off the engine, wait one minute before checking the level.

- » If the engine oil is not up to lower edge **A** of the level viewer:
  - Add engine oil. (p. 145)

## 18.3 Changing the engine oil and oil filter, cleaning the oil screens



### WARNING

**Danger of scalding** Engine and gear oil heat up when the motorcycle is operated.

- Wear suitable protective clothing and safety gloves.
- In the event of scalding, rinse the area affected immediately with lukewarm water.



### NOTE

**Environmental hazard** Hazardous substances cause environmental damage.

- Dispose of oils, grease, filters, fuel, cleaning agents, brake fluid, etc. correctly and in accordance with the applicable regulations.



### Note

Drain the engine oil with the engine at operating temperature.

### Preparatory work

(All special models / XW-F)

- Remove the skid plate. (p. 99)
- Park the motorcycle on a level surface.

## Replacement process

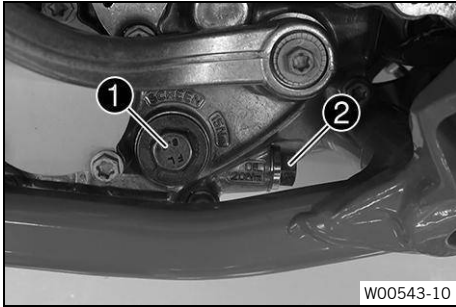

- Position an appropriate container under the engine.
- Remove screw plug **1** with oil screen and the O-rings.
- Remove oil drain plug **2** with the magnet and seal ring.

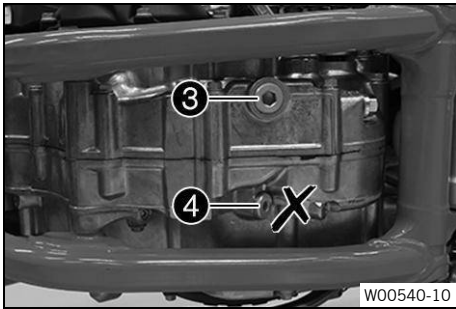

- Remove screw plug **3** with O-ring.

Do not remove screw **4**.

- Allow the engine oil to drain completely.
- Thoroughly clean the parts and the sealing surfaces.
- Mount and tighten screw plug **3** with new O-ring.

Plug, oil screen

M20×1.5

15 Nm

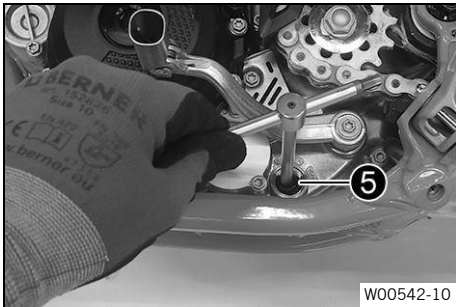

- Position oil screen **5** with the O-rings on a pin wrench.
- Position the pin wrench through the drill hole of the screw plug in the opposite section of the engine case.
- Push the oil screen all the way into the engine case.

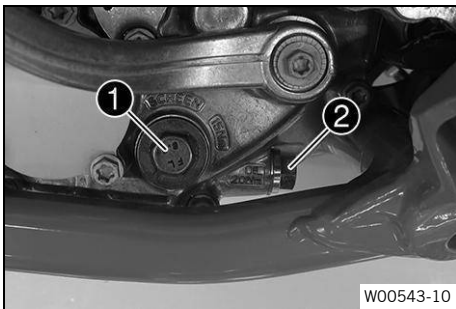

- Mount and tighten screw plug **1** with O-ring.

Plug, oil screen

M20×1.5

15 Nm

- Mount and tighten oil drain plug **2** with the magnet and a new seal ring.

Oil drain plug with magnet

M12×1.5

20 Nm

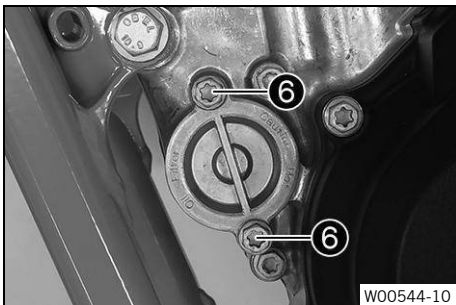

- Remove **6** screws. Take off the oil filter cover with the O-ring.



W00545-10

- Pull oil filter 7 out of the oil filter housing.

Lock ring plier (51012011000)
-------------------------------

- Allow the engine oil to drain completely.
- Thoroughly clean the parts and the sealing surface.

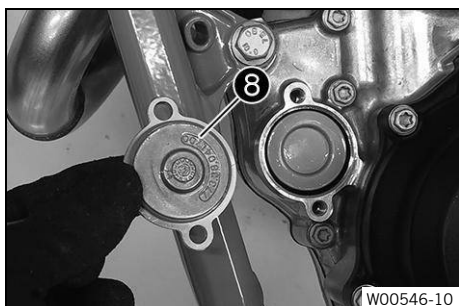

W00546-10

- Lay the motorcycle on its side and fill the oil filter housing to about 1/3 full with engine oil.
- Insert the new oil filter into the oil filter housing.
- Oil the O-ring of the oil filter cover and mount it together with oil filter cover 8.
- Mount and tighten the screws.

Screw, oil filter cover
-------------------------

M6	10 Nm
----	-------

- Stand the motorcycle upright.

- Remove filler plug 9 with the O-ring, and fill up with engine oil.

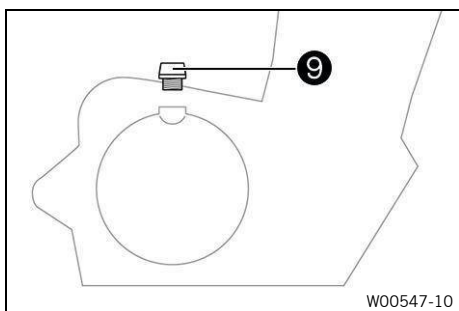

W00547-10

engine oil
------------

Engine oil (10W/50) 📖 (p. 165) fully synthetic	1.0 l
--	-------

**Note**

Too little engine oil or poor-quality engine oil will result in premature wear of the engine.

- Mount and tighten the oil plug together with the O-ring.



**DANGER**

**Danger of poisoning** Exhaust gases are toxic and inhaling them may result in unconsciousness and death.

- Always ensure that there is sufficient ventilation when running the engine.
- Use suitable exhaust extraction when starting or running the engine in an enclosed space.

- Start the engine and check it for leaks.

**Reworking**

(All special models / XW-F)

- Install the skid plate. 📖 (p. 100)
- Check the engine oil level. 📖 (p. 142)

18.4 Adding engine oil



**Note**

Too little engine oil or poor-quality engine oil will result in premature wear of the engine.

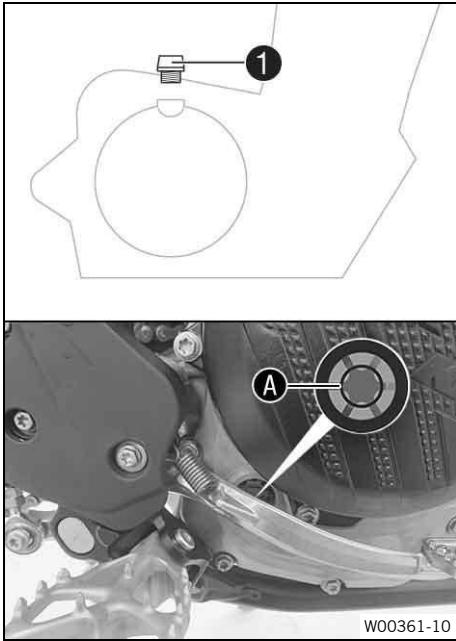

**Filling procedure**

- Remove oil filler plug ① with the O-ring from the clutch cover.
- Fill engine oil to the middle ① of the level viewer.

engine oil	
Engine oil (10W/50) 📖 (p. 165) fully synthetic	1.0 l



**Note**

In order to achieve optimal engine oil performance, it is not advisable to mix different engine oils. KTM recommends changing the engine oil if necessary.

- Mount and tighten the filler plug together with the O-ring.



**DANGER**

**Danger of poisoning** Exhaust gases are toxic and inhaling them may result in unconsciousness and death.

- Always ensure that there is sufficient ventilation when running the engine.
- Use suitable exhaust extraction when starting or running the engine in an enclosed space.

- Start the engine and check it for leaks.

**Reworking**

- Check the engine oil level. 📖 (p. 142)

## 19.1 Cleaning the motorcycle



### NOTE

**Material damage** Components can be damaged or destroyed if a high-pressure cleaner is used incorrectly. The high pressure forces water into the electrical components, socket connectors, clutch cables, and bearings, etc.

Too high a pressure can cause malfunctions and destroy components.

- Do not direct the water jet directly on to electrical components, socket connectors, clutch cables, or bearings.
- Maintain a minimum distance between the nozzle of the high-pressure cleaner and the component.

Minimum distance	60 cm
------------------	-------



### NOTE

**Environmental hazard** Hazardous substances cause environmental damage.

- Dispose of oils, grease, filters, fuel, cleaning agents, brake fluid, etc. correctly and in accordance with the applicable regulations.



### Note

Clean the motorcycle regularly to maintain its value and appearance over a long period.

Avoid direct sunshine when cleaning the motorcycle.

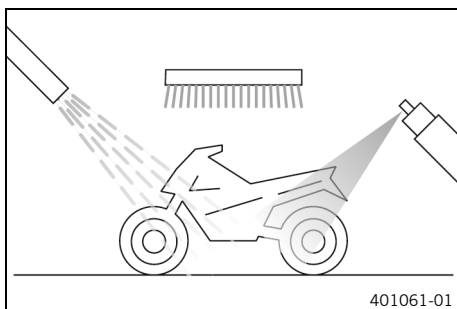

- Close off the exhaust system to keep water from entering.
- Remove the coarse dirt particles with a gentle water jet.
- Spray the heavily soiled parts with a standard commercial motorcycle cleaner and clean using a brush.

Environmentally neutral universal cleaning agent  
 (p. 168)



### Note

Use warm water containing standard motorcycle cleaner and a soft sponge.

Never apply motorcycle cleaner to a dry vehicle; always rinse the vehicle with water first.

- Clean the motorcycle thoroughly with a soft water jet, then allow to dry.
- Remove the cover from the exhaust system.



### WARNING

**Danger of accidents** Moisture and dirt impair the brake system.

- Brake carefully several times to dry out and remove dirt from the brake pads and the brake discs.

- After cleaning, ride the vehicle a short distance until the engine warms up.



### Note

The heat produced causes water to evaporate at inaccessible locations in the engine and on the brake system.

- After the motorcycle has cooled off, lubricate all moving parts and pivot points.
- Clean the chain. (p. 89)

- Treat bare metal (except for brake discs and the exhaust system) with an anticorrosive.

Preserving materials  (p. 168)

- Treat all plastic parts and powder-coated parts with a mild cleaning and care product.

Cleaning agents for plastics, glass, lacquers, metals, windshields and visors  (p. 168)

### (All EU models / AR)

- Lubricate the steering lock.

Universal oil spray  (p. 165)



## 19.2 Checks and maintenance steps for winter operation



### WARNING

**Danger of accidents** Salt on the roads impairs the brake system.

- Brake carefully several times to remove salt from the brake linings and the brake discs.



### WARNING

**Danger of accidents** Oil, grease or wax on the brake discs reduces the brake action.

- Always keep the brake discs free of oil, fat and wax.
- Clean the brake discs with brake cleaner when necessary.



### Note

If you use the vehicle in winter, you must expect salt on the roads. You should therefore take precautions against aggressive road salt.

If the vehicle was operated in road salt, clean it with cold water after riding. Warm water enhances the corrosive effects of salt.

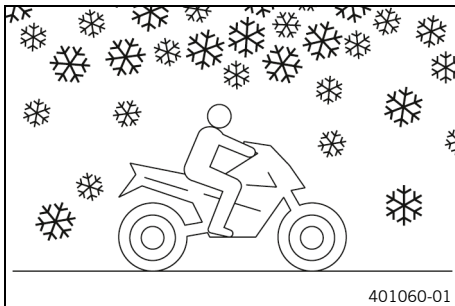

- Clean the motorcycle.  (p. 146)
- Clean brake system.



### Note

After every trip on salted roads, thoroughly wash the brake calipers and brake pads with cold water and dry carefully. This should be done after the parts are cooled down and while they are installed.

After riding on salted roads, thoroughly clean the vehicle with cold water and dry it well.

- Treat the engine, link fork, and all other bare or zinc-plated parts (except the brake discs) with a wax-based corrosion inhibitor.
- Clean the chain.  (p. 89)



## 20.1 Storage



### WARNING

**Danger of poisoning** Fuel is harmful to health.

- Do not allow fuel to come into contact with skin, eyes, or clothing.
- Consult a doctor immediately if fuel has been ingested.
- Do not inhale fuel vapors.
- Rinse the affected area immediately with plenty of water in the event of contact with skin.
- Rinse eyes thoroughly with water and consult a doctor immediately if fuel comes into contact with eyes.
- If fuel spills on to your clothing, change the clothing.
- Store fuel properly in a suitable container and keep out of the reach of children.



### Note

If the vehicle will not be ridden for an extended period, additional steps are recommended.

Before storing the motorcycle, check all parts for function and wear. If service, repairs, or replacements are necessary, you should do this during the storage period (workshops less busy). This allows you to avoid long waiting periods when the next season starts.

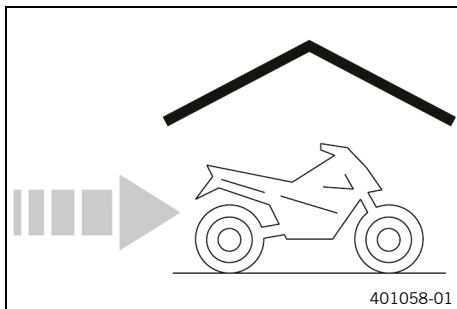

- When refueling for the last time before taking the motorcycle out of service, add fuel additive.









Fuel additive  (p. 164)
--

- Refuel.  (p. 50)



### Tip

Fill the fuel tank completely as specified, using fuel with the lowest possible ethanol content.

- Clean the motorcycle.  (p. 146)
- Change the engine oil and the oil filter, clean the oil screens.   (p. 142)
- Check the frost protection and coolant level.  (p. 129)
- Check the tire pressure.  (p. 116)
- Remove the 12 V battery.   (p. 118)
- Charge the 12 V battery.   (p. 120)

Storage temperature of the 12 V battery without direct sunlight	0 °C ... 35 °C
---	----------------

- Store the vehicle in a dry location that is not subject to large fluctuations in temperature.



### Note

KTM recommends jacking up the motorcycle.

- Raise the motorcycle with a lift stand.  (p. 65)

Preferably cover the motorcycle with a tarp or similar cover that is permeable to air. Do not use non-porous materials since they prevent humidity from escaping, and, as a result, contribute to corrosion.

**Note**

Avoid running the engine of a motorcycle in storage for a short time only. Since the engine cannot warm up properly, the water vapor produced during combustion condenses and causes valves and the exhaust system to rust.





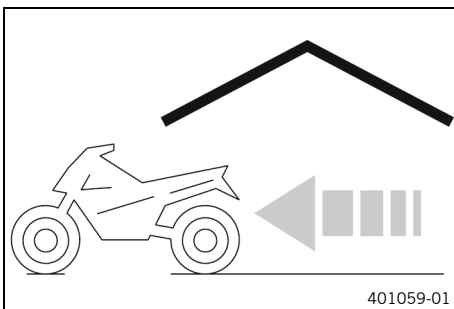























## 20.2 Preparing for use after storage



- Remove the motorcycle from the lift stand. (p. 65)
- Install the 12 V battery. (p. 119)
- Perform checks and maintenance measures when preparing for use. (p. 45)
- Take a test ride.



## 21.1 troubleshooting

Cause	Finding	Remedy		
The engine does not turn over (starter motor)	Operating error 12 V battery discharged Main fuse blown Starter relay defective Starter motor defective	<ul style="list-style-type: none"> <li>– Carry out the starting procedure.  (p. 45)</li> <li>– Charge the 12 V battery. </li> <li>– Check the charging voltage. </li> <li>– Check the open-circuit current. </li> <li>– Check the stator winding of the alternator. </li> <li>– Change the main fuse.  (p. 122)</li> <li>– Check the starter relay. </li> <li>– Check the starter motor. </li> </ul>		
The engine turns but does not start	Operating error Quick-lock coupling not joined Error in the circuit, OCU LED <b>A</b> and <b>D</b> lights up. Idle speed is not set correctly Spark plug sooty or wet Plug gap of spark plug too wide Faulty ignition Short-circuit cable in wiring harness frayed, stop button or emergency OFF switch faulty Error in the electronic fuel injection	<ul style="list-style-type: none"> <li>– Carry out the starting procedure.  (p. 45)</li> <li>– Join quick-lock couplings.</li> <li>– Check the electrical system.</li> <li>– Adjust the idle speed.   (p. 138)</li> <li>– Clean and dry the spark plug and spark plug connector, or change if necessary.</li> <li>– Adjust plug gap.</li> </ul> <table border="1" style="width: 100%; border-collapse: collapse;"> <tr> <td style="padding: 2px;">Plug gap of spark plug</td> <td style="padding: 2px;">1.0 mm</td> </tr> </table> <ul style="list-style-type: none"> <li>– Check the ignition system. </li> <li>– Check the wiring harness. (Visual check).</li> <li>– Check the electrical system.</li> <li>– Read out the fault memory using the diagnostics tool. </li> </ul>	Plug gap of spark plug	1.0 mm
Plug gap of spark plug	1.0 mm			
Engine does not speed up	Error in the electronic fuel injection Faulty ignition	<ul style="list-style-type: none"> <li>– Read out the fault memory using the diagnostics tool. </li> <li>– Ignition coil - check the secondary winding. </li> <li>– Check the spark plug connector. </li> <li>– Check the stator winding of the alternator. </li> </ul>		
Engine has too little power	Air filter is very dirty Fuel filter is very dirty Fuel screen is very dirty Error in the electronic fuel injection Exhaust system leaks, deformed or too little glass fiber filling in the silencer Valve clearance too little Faulty ignition	<ul style="list-style-type: none"> <li>– Clean the air filter and air filter box.   (p. 81)</li> <li>– Change the fuel filter. </li> <li>– Change the fuel screen. </li> <li>– Read out the fault memory using the diagnostics tool.  (p. 141)</li> <li>– Read out the fault memory using the diagnostics tool. </li> <li>– Check exhaust system for damage.</li> <li>– Change the glass fiber filling of the muffler.   (p. 85)</li> <li>– Adjust the valve clearance. </li> </ul>		



Cause	Finding	Remedy		
		<ul style="list-style-type: none"> <li>– Ignition coil - check the secondary winding. 🔧</li> <li>– Check the spark plug connector. 🔧</li> <li>– Check the stator winding of the alternator. 🔧</li> </ul>		
The engine dies during the trip	Lack of fuel Error in the circuit, OCU LED <b>A</b> and <b>D</b> lights up.	<ul style="list-style-type: none"> <li>– Refuel. 📖 (p. 50)</li> <li>– Check the electrical system.</li> </ul>		
Engine overheats	Too little coolant in cooling system Too little air stream Radiator fins very dirty Foam formation in the cooling system Bent radiator hose Thermostat defective Defect in the radiator fan system, OCU LED <b>E</b> lights up.	<ul style="list-style-type: none"> <li>– Check the transmission and cooling system for leaks.</li> <li>– Check the coolant level. 📖 (p. 130)</li> <li>– Switch off the engine when standing.</li> <li>– Clean the radiator fins.</li> <li>– Drain the coolant. 🔧 📖 (p. 131)</li> <li>– Refill the coolant. 🔧 📖 (p. 132)</li> <li>– Change the radiator hose. 🔧</li> <li>– Check the thermostat. 🔧</li> </ul> <table border="1" style="margin-left: 20px;"> <tr> <td>Opening temperature</td> <td>70 °C</td> </tr> </table> <ul style="list-style-type: none"> <li>– Check the radiator fan. 🔧</li> <li>– Check the electrical system.</li> </ul>	Opening temperature	70 °C
Opening temperature	70 °C			
Malfunction indicator lamp lights up or flashes	Error in the electronic fuel injection	<ul style="list-style-type: none"> <li>– Check wiring for damage and electrical plug-in connectors for corrosion and damage.</li> <li>– Read out the fault memory using the diagnostics tool. 🔧</li> </ul>		
High oil consumption	Engine vent hose bent The engine oil level is too high The engine oil is too thin (low viscosity) Piston and cylinder worn	<ul style="list-style-type: none"> <li>– Route the vent hose without bends or change it if necessary.</li> <li>– Check the engine oil level. 📖 (p. 142)</li> <li>– Change the engine oil and the oil filter, clean the oil screens. 🔧 📖 (p. 142)</li> <li>– Measure the piston/cylinder mounting clearance. 🔧</li> </ul>		
12 V battery discharged	The 12-V battery is not being charged by the alternator unwanted electrical load	<ul style="list-style-type: none"> <li>– Check the charging voltage. 🔧</li> <li>– Check the stator winding of the alternator. 🔧</li> <li>– Check the open-circuit current. 🔧</li> </ul>		
Values in combination instrument deleted (time, stop watch, lap times)	The combination instrument battery is empty	<ul style="list-style-type: none"> <li>– Change combination instrument battery. 📖 (p. 127)</li> </ul>		
Fault with the lighting system or horn.	Error in the circuit, OCU LED <b>B</b> or <b>C</b> lights up.	<ul style="list-style-type: none"> <li>– Check the electrical system.</li> </ul>		

## 22.1 Engine

### 22.1.1 Technical data - engine

Design	1-cylinder 4-stroke engine, water-cooled
Displacement	349.7 cm <sup>3</sup>
Stroke	57.5 mm
Bore	88 mm
Compression ratio	13.7:1
Control	DOHC, four valves controlled via cam lever, drive via timing chain
Valve diameter, intake	36.3 mm
Valve diameter, exhaust	29.1 mm
Valve clearance	
Intake at: 20 °C	0.08 mm ... 0.15 mm
Exhaust at: 20 °C	0.12 mm ... 0.19 mm
Crankshaft bearing	2-cylinder roller bearing
Big (bottom) end bearing	Plain bearing
Wrist pin bearing	Bearing bush
Piston	Forged light alloy
Piston rings	1 compression ring, 1 oil scraper ring
Engine lubrication	Pressure circulation lubrication with 2 trochoidal pumps
Primary transmission	24:72
Clutch	Multidisc clutch in oil bath/hydraulically activated/damped
Transmission	6 speed transmission, claw shift
Gear ratios	
1st gear	13:33
2nd Gear	16:30
3rd Gear	18:26
4th Gear	22:26
5th Gear	23:23
6th Gear	26:22
Alternator	<ul style="list-style-type: none"> <li>• 14 V</li> <li>• 200 W</li> </ul>
Ignition system	Contactless controlled fully electronic ignition with digital ignition adjustment
Spark plug	NGK LMAR9AI-10
Plug gap of spark plug	1.0 mm
Cooling	Liquid cooling, permanent circulation of coolant by water pump
Starting aid	Starter motor
Idle speed	1,950 rpm ... 2,050 rpm

**22.1.2 Capacities - engine**

engine oil	
Engine oil (10W/50)  (p. 165) fully synthetic	1.0 l
coolant	
Coolant  (p. 166) Antifreeze protection to at least: -25 °C	0.95 l

**22.2 Chassis**
**22.2.1 Technical data - chassis**

Frame	Central tube frame made of chrome molybdenum steel tubing
Fork	WP XPLOR Closed Cartridge
Suspension travel:	
front	300 mm
rear	310 mm
Triple clamp offset	22 mm
Shock absorber	<b>WP PDS</b>
Brake system	Disc brakes, floating brake calipers
Brake discs diameter	
front	260 mm
rear	220 mm
Brake disc wear limit <b>(All except SIX DAYS)</b>	
front	2.5 mm
rear	3.5 mm
Brake disc wear limit <b>(EXC-F SIX DAYS)</b>	
front	2.5 mm
rear	3.7 mm
Street tire pressure	
front	2.0 bar
rear	2.0 bar
Final drive	14:48
Chain	5/8 x 1/4"
Rear sprockets available	<ul style="list-style-type: none"> <li>• 48 teeth</li> <li>• 50 teeth</li> <li>• 52 teeth</li> </ul>
Steering head angle	63.9°
Wheelbase	1,488 ±10 mm
Seat Height unloaded	963 mm
Ground clearance unloaded	347 mm
Weight without fuel approx.	
<b>(All standard models)</b>	107 kg
<b>(All special models)</b>	107.3 kg

## 22 Technical specifications

Maximum permissible front axle load	145 kg
Maximum permissible rear axle load	190 kg
Maximum permissible total weight	335 kg



### 22.2.2 Technical data - tires

Street tire pressure	
front	2.0 bar
rear	2.0 bar
Off-road tire pressure	
front	1.0 bar
rear	1.0 bar

Validity	Tire front	Rear tire
(EXC-F EU / AR)	90/90 - 21 M/C 54R M+S TT MAXXIS Maxx Enduro	140/80 - 18 M/C 70R M+S TT MAXXIS Maxx Enduro
(EXC-F BR / EXC-F SIX DAYS)	90/90 - 21 M/C 54M M+S TT Metzeler MCE 6 Days Extreme	140/80 - 18 M/C 70M M+S TT Metzeler MCE 6 Days Extreme
(CHAMPION EDITION)	90/90 - 21 54R M+S TT Michelin Enduro Medium	140/80 - 18 70R M+S TT Michelin Enduro Medium
(XW-F)	80/100 - 21 51M M+S TT Dunlop MX33F	110/100 - 18 64M M+S TT Dunlop Geomax AT81

The tires specified represent one of the possible series production tires. For alternative manufacturers, if any, contact an authorized dealer or qualified tire dealership. If local road approval regulations apply, these and the respective technical specifications must be observed.

### 22.2.3 Capacities - vehicle

Total fuel tank capacity, approx.	
(All except BR models) Super unleaded (ROZ 95)  (p. 164)	8.5 l
(All BR-models) Super unleaded, type C (ROZ 95/RON 95/PON 91)  (p. 164)	

## 22.3 Electrics

### 22.3.1 Battery

12-V battery	HJTZ5S-FP-C	Lithium-ion battery Battery voltage: 12 V Nominal capacity: 2.0 Ah Maintenance-free
Button cell	CR 2430	Battery voltage: 3 V

**22.3.2 Fuses**

Fuse	58011109120	20 A
------	-------------	------

**22.3.3 Lamps**



Dashboard illumination and indicator lights	LED	
Low beam	LED	
Parking light	LED	
high beam	LED	
Turn signal	RY10W / Socket BAU15s	12 V 10 W
Brake light	LED	
Tail light	LED	
License plate lighting	LED	

**22.4 Fork**

**22.4.1 Technical data - fork**

Fork part number	A490C167X402000	
Compression damping		
Comfort	17 clicks	
Standard	15 clicks	
Sport	7 clicks	
Rebound damping		
Comfort	19 clicks	
Standard	17 clicks	
Sport	9 clicks	
Spring length with preload spacer(s)	476 mm	
Spring rate		
Weight of rider: 65 kg ... 75 kg	4.4 N/mm	
Weight of rider: 75 kg ... 85 kg	4.6 N/mm	
Weight of rider: 85 kg ... 95 kg	4.8 N/mm	
Fork length	940 mm	

**22.4.2 Capacities - fork**

Oil capacity, outer assembly	
Fork oil (48601166S1) (SAE 4)  (p. 165)	390 ml
Oil capacity, cartridge	
Fork oil (48601166S1) (SAE 4)  (p. 165)	175 ml

## 22.5 Shock absorber

### 22.5.1 Technical data - shock absorber

Shock absorber part number	A490C467Y305000
Low-speed compression damping	
Comfort	18 clicks
Standard	15 clicks
Sport	12 clicks
High-speed compression damping	
Comfort	2.5 turns
Standard	2 turns
Sport	1.5 turns
Rebound damping	
Comfort	18 clicks
Standard	15 clicks
Sport	12 clicks
Preload	7 mm
Spring rate	
Weight of rider: 65 kg ... 75 kg	69 N/mm
Weight of rider: 75 kg ... 85 kg	72 N/mm
Weight of rider: 85 kg ... 95 kg	75 N/mm
Spring length	225 mm
Gas assisted	10 bar
Static sag	38 mm
Rider sag	110 mm
Installation position	402.7 mm

### 22.5.2 Capacities - shock absorber

Oil capacity, shock absorber	
Shock absorber oil (50180751S1) (SAE 2.5)  (p. 166)	Fill to the maximum mark

## 22.6 Tightening torque

### 22.6.1 engine tightening torques

Oil nozzle for main bearing lubrication	M4	2 Nm	<b>Loctite® 243</b>
Oil nozzle for clutch lubrication	M4	2 Nm	<b>Loctite® 243</b>
Screw, oil nozzle bent for piston cooling	M4	2.5 Nm	<b>Loctite® 243</b>
Jet, crank chamber ventilation	M4	2 Nm	<b>Loctite® 243</b>

Hose clip, intake flange	M4	3 Nm
Detent arm screw	M5	6 Nm <b>Loctite® 243</b>
Screw, gear position sensor	M5	5 Nm <b>Loctite® 243</b>
Screw, clutch spring	M5	6 Nm
Suction/pressure pump oil pump cover screw	M5	6 Nm <b>Loctite® 243</b>
Oil pump idler gear fuse screw	M5	6 Nm <b>Loctite® 243</b>
Oil nozzle for piston cooling	M5	2 Nm <b>Loctite® 243</b>
Screw, bearing retainer	M5	6 Nm <b>Loctite® 243</b>
Stator screw	M5	6 Nm <b>Loctite® 2701</b>
Alternator cover grub screw	M5	2 Nm <b>Loctite® 243</b>
Shift star screw	M6	10 Nm <b>Loctite® 243</b>
Exhaust flange screw	M6	10 Nm <b>Loctite® 243</b>
Screw, guide rail	M6	10 Nm <b>Loctite® 243</b>
Screw, timing chain failure protection	M6	10 Nm <b>Loctite® 243</b>
Screw, starter motor	M6	10 Nm
Fuel vapor retention system connection screw	M6	5 Nm <b>Loctite® 243</b>
Screw, fuel vapor retention system lock	M6	5 Nm <b>Loctite® 243</b>
Screw, outer clutch cover	M6	10 Nm
Screw, inner clutch cover	M6	10 Nm
Screw, clutch slave cylinder	M6	10 Nm
Screw, engine case	M6	10 Nm
Screw, oil filter cover	M6	10 Nm
Screw, shift lever	M6	14 Nm <b>Loctite® 243</b>

## 22 Technical specifications

Screw, starter motor - intermediate gear	M6	10 Nm	<b>Loctite® 243</b>
Screw, valve cover	M6	8 Nm	
Stud, cylinder head	M6	6 Nm	<b>Loctite® 243</b>
Nut, cylinder head	M6	10 Nm	
Screw, water pump cover	M6	10 Nm	
Nut, water pump impeller	M6	6 Nm	<b>Loctite® 243</b>
Screw, ignition cover	M6	10 Nm	
Autodecompressor screw plug	M7×1	15 Nm	<b>Loctite® 243</b>
Screw, camshaft bearing bridge	M7×1 Engine oil	1.	5 Nm
		2.	14 Nm
Slide rail screw	M8	15 Nm	<b>Loctite® 243</b>
Crankshaft clamp screw plug	M8	10 Nm	
Crankshaft fixing screw	M8	8 Nm	
Screw plug, cam lever shaft	M10×1	10 Nm	
Front sprocket screw	M10	60 Nm	<b>Loctite® 243</b>
Chain tension adjuster finger follower shaft plug	M10×1	8 Nm	
Screw, rotor	M10×1	70 Nm	Engine oil
Coolant temperature sensor	M10×1.25	12 Nm	
Oil channel screw plug	M10×1	15 Nm	<b>Loctite® 243</b>
Stud, cylinder head	M10×1.25	20 Nm	<b>Loctite® 243</b>
Nut, cylinder head	M10×1.25 Engine oil	1.	10 Nm
		2.	30 Nm
		3.	180°
Spark plug	M10×1	12 Nm	
Oil drain plug with magnet	M12×1.5	20 Nm	

Pressure control valve plug	M12×1.5	20 Nm
Oil drain plug	M14×1.5	15 Nm
Nut, inner clutch hub	M18×1.5	100 Nm
Nut, primary gear wheel	M18LH×1.5	120 Nm <b>Loctite® 243</b>
Plug, oil screen	M20×1.5	15 Nm
Screw plug, timing chain tensioner	M24×1.5	40 Nm
Oil plug	M24×3	hand-tight
Screw plug, alternator cover	M24×1.5	18 Nm <b>Loctite® 243</b>

### 22.6.2 Chassis tightening torques

Screw, radiator hoses clip		2.8 Nm
Hose connector, active carbon filter		3.8 Nm
Mushroom head screw for spoiler and seat		2.5 Nm
Screw, radiator hoses clip		2.8 Nm
Screw, fixed grip	M4	5 Nm <b>Loctite® 243</b>
Screw, hose clamp, throttle body	M4	5 Nm
Remaining nuts on chassis	M5	5 Nm
Remaining screws on chassis	M5	5 Nm
Screw, battery terminal	M5	2.5 Nm
Screw, light switch	M5	1 Nm
Screw, turn signal switch	M5	1 Nm
<b>(XW-F)</b> Screw, intake air temperature sensor	M5	2.7 Nm
Screw, frame protector	M5	3 Nm
Screw, throttle body cover	M5	2.6 Nm

## 22 Technical specifications

Nut, starter motor	M6	4 Nm
Remaining nuts on chassis	M6	10 Nm
Remaining screws on chassis	M6	10 Nm
Screw, throttle twist grip	M6	5 Nm
Screw, rear brake disc	M6	14 Nm <b>Loctite® 243</b>
Screw, front brake disc	M6	14 Nm <b>Loctite® 243</b>
Screw, chain slider guard	M6	6 Nm <b>Loctite® 243</b>
Screw, ball joint of push rod on brake cylinder	M6	10 Nm <b>Loctite® 243</b>
Fender screw	M6	12 Nm
Screw, seat installation	M6	8 Nm
Brake line guide screw on swingarm	M6	4.5 Nm <b>Loctite® 243</b>
Screw, connector support incl. dashboard	M6	5 Nm
Screw, ground wire on frame	M6	10 Nm
Screw, starter cable to starter relay	M6	6 Nm
Screw, hand lever	M6	5 Nm
Screw, battery holding bracket	M6	6 Nm
Screw, fuel tank spoiler on radiator	M6	6 Nm
Nut, throttle cable on throttle body	M6	3 Nm
Screw, chain guide	M6	10 Nm <b>Loctite® 243</b>
Nut, rear sprocket screw	M8	35 Nm <b>Loctite® 2701</b>
Nut, rim lock	M8	12 Nm
Nut, brake pedal stop	M8	20 Nm
Remaining nuts on chassis	M8	25 Nm

Remaining screws on chassis	M8	25 Nm
Screw, front brake caliper	M8	25 Nm <b>Loctite® 243</b>
<b>(EXC-F SIX DAYS)</b> Screw, top triple clamp	M8	17 Nm
<b>(All except SIX DAYS)</b> Screw, top triple clamp	M8	20 Nm
<b>(EXC-F SIX DAYS)</b> Screw, bottom triple clamp	M8	12 Nm
<b>(All except SIX DAYS)</b> Screw, bottom triple clamp	M8	15 Nm
Screw, fork shoe	M8	15 Nm
Screw, upper steering stem	M8	20 Nm <b>Loctite® 243</b>
Screw, manifold	M8	15 Nm
Handlebar clamp screw	M8	20 Nm
Screw, chain slider	M8	15 Nm
Screw, engine brace on engine	M8×20	25 Nm <b>Loctite® 243</b>
Screw, subframe, top	M8	35 Nm <b>Loctite® 243</b>
Screw, side stand attachment	M8	33 Nm <b>Loctite® 2701</b>
Screw, subframe, bottom	M8	30 Nm <b>Loctite® 2701</b>
Screw, engine brace on frame	M8×15	25 Nm <b>Loctite® 2701</b>
Screw, front sprocket cover	M8	15 Nm
Screw, brake caliper on brake caliper bracket	M10	45 Nm <b>Loctite® 243</b>
Engine bracket screw	M10	60 Nm
Remaining nuts on chassis	M10	45 Nm
Remaining screws on chassis	M10	45 Nm
Screw, handlebar mount	M10	40 Nm <b>Loctite® 243</b>

## 22 Technical specifications

Screw, sprocket	M10	60 Nm <b>Loctite® 2701</b>
Top shock absorber screw	M12	80 Nm <b>Loctite® 2701</b>
Bottom shock absorber screw	M12	80 Nm <b>Loctite® 2701</b>
Nut, swingarm pivot	M16×1.5	100 Nm
Screw, top steering head	M20×1.5	12 Nm
Screw, wheel spindle, front	M20×1.5	35 Nm
Nut, wheel spindle, rear	M22	80 Nm
Screw-in nozzle, cooling system	M24×1.5	7.5 Nm <b>Loctite® 243</b>
<b>(350 EXC-F AR350 EXC-F BR350 EXC-F CHAMPION EDITION EU350 EXC-F EU)</b> Outer diaphragm fitting	<b>EJOT PT® – 35×25</b>	0.8 Nm
<b>(All except SIX DAYS)</b> Inner diaphragm fitting	<b>EJOT PT® – 35×25</b>	1 Nm
Spoke nipple, front wheel	M4,5	6 Nm
Spoke nipple, rear wheel	M4,5	6 Nm
Screw, intake air temperature sensor	<b>EJOT PT® – 50×18</b>	0.7 Nm
Screw, emergency OFF switch	<b>EJOT PT® – K50×18</b>	2 Nm
<b>(All special models)</b> Combination switch screw	<b>EJOT PT® – K50×18</b>	2 Nm
Screw, pressure regulator	<b>EJOT PT® – K60×25 – Z</b>	2.3 Nm
Screw, seat installation	<b>EJOT EJOFORM® – K60×23/18</b>	2.5 Nm
Remaining screws on chassis	<b>EJOT PT® – K60×25 – Z</b>	2 Nm
Screw, fuel pump	<b>EJOT PT® – M60×30</b>	2.5 Nm
Screw, air filter box on subframe	<b>EJOT PT® – 60×20</b>	5 Nm

**A Technical terms**

	Launch control	Vehicles electronics functions for achieving the best possible acceleration from a standing position
	Quickshifter	Function of the engine electronics for shifting up without clutch actuation
OBD	On-board diagnosis	Vehicle system, which monitors the specified parameters of the vehicle electronics

## **B Fuels**

### **Super unleaded**

#### **Standards**

- ROZ 95 → DIN EN 228

### **Super unleaded, type C**

#### **Standards**

- ROZ 95/RON 95/PON 91 → ANP (Agência Nacional do Petróleo) #57

### **Fuel additive**

#### **Recommended supplier**

**MOTOREX®**

- **FUEL STABILIZER**

**C Operating supplies****Off-road chain spray****Recommended supplier**

MOTOREX®

- CHAINLUBE OFF ROAD

**Fork oil****Order details**

- 48601166S1

**Standards**

- SAE 4 → SAE

**Universal oil spray****Recommended supplier**

MOTOREX®

- JOKER 440 SYNTHETIC

**Long-life grease****Recommended supplier**

MOTOREX®

- 2000

**Engine oil****Recommended supplier**

MOTOREX®

- CROSS POWER 4T

**Standards**

→ JASO T903 MA2

- 10W/50 → SAE

**Properties**

- fully synthetic

**Engine oil****Recommended supplier**

MOTOREX®

- TOP SPEED 4T

## Standards

→ JASO T903 MA2

- 15W/50 → SAE

## Properties

- Partially synthetic

## High viscosity grease

### Recommended supplier

SKF®

- LGHB 2

## Silicone spray

### Recommended supplier

MOTOREX®

- SILICONE SPRAY

## Shock absorber oil

### Order details

- 50180751S1

## Standards

- SAE 2.5 → SAE

## Oil for foam air filter

### Recommended supplier

MOTOREX®

- RACING BIO AIR FILTER OIL

## Brake fluid DOT 4 / DOT 5.1

### Recommended supplier

Castrol

- REACT PERFORMANCE DOT 4

MOTOREX®

- BRAKE FLUID DOT 5.1

## Standards

→ DOT

## Coolant

### Recommended supplier

**MOTOREX®**

- **COOLANT M3.0**
- 

**Properties**

- Antifreeze protection to at least -25 °C
-

## D Cleaning agents

### Chain cleaner

Recommended supplier

MOTOREX®

- CHAIN CLEAN

### Preserving materials

Recommended supplier

MOTOREX®

- MOTO PROTECT

### Air filter cleaning agent

Recommended supplier

MOTOREX®

- RACING BIO AIR FILTER CLEANER

### Cleaning agents for plastics, glass, lacquers, metals, windshields and visors

Recommended supplier

MOTOREX®

- QUICK CLEANER

### Environmentally neutral universal cleaning agent

Recommended supplier

MOTOREX®



- MOTO CLEAN UNIVERSAL

## E Icons

### E.1 Symbol colors



#### E.1.1 Yellow and orange symbols

Yellow and orange symbols indicate a malfunction status that requires prompt intervention. Active driving aids are also represented by yellow or orange symbols.

	Failure indicator light lights up/flashes yellow.
	Fuel level warning light lights up yellow.

#### E.1.2 Green and blue symbols

Green and blue symbols convey information.

	Turn signal indicator light flashes green.
	The high beam indicator light lights up blue.

<b>1</b>		
<b>12 V battery</b>		
charging	120	
installation	119	
removing	118	
starting power	41	
<b>A</b>		
<b>Accessories</b>	14	
<b>Air filter</b>		
cleaning	81	
installing	81	
removing	80	
<b>Air filter box</b>		
cleaning	81	
<b>Air filter box cover</b>		
installing	80	
preparing for securing	82	
removing	79	
<b>Auxiliary substances</b>	14	
<b>B</b>		
<b>Battery</b>	154	
<b>Brake discs</b>		
checking	101	
<b>Brake fluid</b>		
adding front brake	102	
adding to rear brake	107	
<b>Brake fluid level</b>		
checking on front brake	102	
checking on rear brake	107	
<b>Brake lining retainers</b>		
checking on front brake	104	
checking on rear brake	109	
<b>Brake pad</b>		
checking on front brake	104	
<b>Brake pads</b>		
changing on the rear brake	109	
checking on rear brake	109	
of the front brake, changing	104	
<b>Brake pedal</b>		
adjusting the basic position	106	
checking the free travel	106	
<b>C</b>		
<b>Chain</b>		
checking	92	
cleaning	89	
<b>Chain guide</b>		
checking	92	
<b>Chain tension</b>		
adjusting	91	
checking	90	
<b>Characteristic map of the throttle response</b>		
adjusting	136	
<b>Checking basic chassis setting with</b>		
rider's weight	55	
<b>Clothing</b>	11	
<b>Clutch</b>		
changing fluid	98	
checking/correcting fluid level	97	
<b>Clutch lever</b>		
adjusting the basic position	98	
<b>Compression damping</b>		
adjusting the fork	61	
<b>Coolant</b>		
antifreeze and coolant level, checking	129	
changing	133	
draining	131	
level, checking	130	
refilling	132	
<b>Customer service</b>	14	
<b>D</b>		
<b>Dashboard</b>		
adjusting	30	
combination instrument battery, changing	127	
overview	28	
setting kilometers or miles	29	
setting the clock	30	
viewing the lap time	31	
<b>Defined use</b>	12	
<b>Diagnostic connector</b>	128	
<b>Difficult operating conditions</b>	42	
dry sand	42	
high temperatures	44	
low temperature	44	
muddy surfaces	43	
slow speed	44	
snow	44	
wet sand	43	
wet surfaces	43	
<b>E</b>		
<b>Engine</b>		
running in	41	
<b>Engine oil</b>		
adding	145	
changing	142	

- Engine oil level**  
checking ..... 142
- Environment** ..... 12
- F**
- Figures** ..... 14
- Fork legs**  
bleeding ..... 65  
checking basic setting ..... 60  
cleaning the dust boots ..... 66  
installing ..... 68  
removing ..... 68
- Fork protector**  
installation ..... 67  
removing ..... 67
- Frame**  
checking ..... 95
- Frame protector**  
installation ..... 67  
removing ..... 67
- Front fender**  
installation ..... 75  
removing ..... 74
- Front sprocket**  
checking ..... 92
- Front wheel**  
installing ..... 113  
removing ..... 112
- Frost protection**  
checking ..... 129
- Fuel screen**  
changing ..... 141
- Fuel tank**  
installation ..... 87  
removing ..... 85
- Fuel tank cap**  
closing ..... 23  
opening ..... 23
- Fuse**  
changing the main fuse ..... 122
- Fuses** ..... 155
- G**
- Gear shift lever**  
adjusting the basic position ..... 140  
checking the basic position ..... 139
- H**
- Hand grip**  
checking ..... 96
- Handbrake lever**  
checking the free travel ..... 101  
free travel, adjusting ..... 101
- Handlebar position** ..... 62  
adjusting ..... 63
- Headlight**  
adjusting headlight range ..... 125
- Headlight bulb**  
changing ..... 124
- Headlight mask with headlight**  
installation ..... 124  
removing ..... 123
- Headlight setting**  
checking ..... 125
- High-speed compression damping**  
adjusting the shock absorber ..... 56
- I**
- Idle speed**  
adjusting ..... 138
- Idle speed adjustment screw** ..... 24
- Implied warranty** ..... 14
- Improper use** ..... 13
- Intended use** ..... 12
- L**
- Lamps** ..... 155
- Lower triple clamp**  
installation ..... 70  
removing ..... 69
- Low-speed compression damping**  
adjusting the shock absorber ..... 55
- M**
- Main fuse**  
changing ..... 122
- Manufacturer's warranty** ..... 14
- Mapping**  
changing ..... 137
- Motorcycle**  
cleaning ..... 146  
raising with lift stand ..... 65  
removing from lift stand ..... 65
- Muffler**  
changing the glass fiber filling ..... 85  
clean spark arrestor ..... 83  
installation ..... 83  
removing ..... 82

<b>O</b>	
<b>OCU</b> .....	128
<b>Oil filter</b>	
changing .....	142
<b>Oil screens</b>	
cleaning .....	142
<b>Owner's manual</b> .....	12
<b>P</b>	
<b>Preparing for use</b>	
after storage .....	149
checks and maintenance measures when preparing for use .....	45
notes on preparing for first use .....	40
<b>Protective clothing</b> .....	11
<b>Q</b>	
<b>Quickshifter</b>	
activating .....	47
programming .....	97
<b>R</b>	
<b>Rear sprocket</b>	
checking .....	92
<b>Rear wheel</b>	
installation .....	114
removing .....	113
<b>Rebound damping</b>	
adjusting the fork .....	61
adjusting the shock absorber .....	56
<b>Refueling</b>	
fuel .....	50
<b>Resources</b> .....	14
<b>Rider sag</b>	
adjusting .....	60
<b>S</b>	
<b>Safe use</b> .....	11
<b>Seat</b>	
mounting .....	78
removing .....	78
<b>Service</b> .....	14
<b>Shock absorber</b>	
adjusting the spring preload .....	59
checking static sag .....	58
checking the rider sag .....	58
installation .....	76
removing .....	75
<b>Skid plate</b>	
installation .....	100
removing .....	99
<b>Spare parts</b> .....	14
<b>Spoke tension</b>	
checking .....	117
<b>Starting</b> .....	45
<b>Starting performance of lithium-ion batteries at low temperatures</b> .....	41
<b>Steering</b>	
locking .....	26
unlocking .....	27
<b>Steering head bearing</b>	
lubricating .....	74
<b>Steering head bearing play</b>	
adjusting .....	73
checking .....	72
<b>Storage</b> .....	148
<b>Swingarm</b>	
checking .....	95
<b>T</b>	
<b>Technical specifications</b>	
tires .....	154
<b>Throttle cable play</b>	
adjusting .....	135
checking .....	135
<b>Throttle cable routing</b>	
checking .....	87, 95
<b>Throttle valve position</b>	
programming .....	139
<b>Tire condition</b>	
checking .....	115
<b>Tire pressure</b>	
checking .....	116
<b>Traction control</b>	
activating .....	46
<b>Transportation</b> .....	49
<b>Turn signal bulb</b>	
changing .....	126
<b>V</b>	
<b>Vehicle identification number</b> .....	17
<b>VIN</b> .....	17
<b>W</b>	
<b>Winter operation</b>	
checks and maintenance steps .....	147
<b>Work rules</b> .....	11



3240049en

20/12/2024

