

250 SX
300 SX
250 XC
300 XC

ART. NO. 3240089EN



Perform the work described in these setup instructions before the vehicle is delivered to the customer.

Read the setup instructions in their entirety before beginning work.

These setup instructions were written to correspond to the latest state of this model series. We reserve the right to make modifications in the interest of technical advancement without at the same time updating these setup instructions.

We shall not provide a description of general workshop methods. Likewise, safety rules that apply in a workshop are not specified here. It is assumed that the work will be performed by a fully trained mechanic.

All specifications contained herein are non-binding. KTM Sportmotorcycle GmbH specifically reserves the right to modify or delete technical specifications, prices, colors, forms, materials, services, designs, equipment, etc., without prior notice and without specifying reasons, to adapt these to local conditions, as well as to stop production of a particular model without prior notice. KTM accepts no liability for delivery options, deviations from figures and descriptions, misprints, and other errors. The models portrayed partly contain special equipment that does not belong to the regular scope of supply.

© 2024 KTM Sportmotorcycle GmbH, Mattighofen Austria

All rights reserved

Reproduction, even in part, as well as copying of all kinds, is permitted only with the express written permission of the copyright owner.



ISO 9001(12 100 6061)

KTM applies quality assurance processes that lead to the highest possible product quality as defined in the ISO 9001 international quality management standard.

Issued by: TÜV SÜD Management Service GmbH

REG.NO. 12 100 6061

KTM Sportmotorcycle GmbH
Stallhofnerstraße 3
5230 Mattighofen, Austria

This document is valid for the following models:

250 SX (F6301Y0)

300 SX (F6401Y1)

250 XC (F6375Y5)

300 XC (F6475Y5)



3240089en

08.05.2024

1 MEANS OF REPRESENTATION

1.1 Symbols used

The meaning of specific symbols is described below.



Indicates an expected reaction (e.g. of a work step or a function).



Indicates an unexpected reaction (e.g. of a work step or a function).



Indicates a page reference (more information is provided on the specified page).



Indicates information with more details or tips.



Indicates the result of a testing step.



Indicates a voltage measurement.



Indicates a current measurement.



Indicates a resistance measurement.



Indicates the end of an activity including potential rework.

1.2 Formats used

The typographical formats used in this document are explained below.

Proprietary name

Indicates a proprietary name.

Name®

Indicates a protected name.

Brand™

Indicates a brand available on the open market.

Underlined terms

Refer to technical details of the vehicle or indicate technical terms, which are explained in the glossary.

2.1 Transport mode

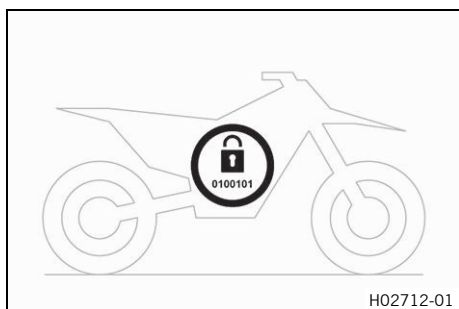

This vehicle was blocked for transport in the software. To operate the vehicle, the vehicle electronics must be enabled. This process is conducted during initial setup in KTM Dealer.net. Enabling ensures that the initial setup in KTM Dealer.net is documented.

Enabling can be performed either temporarily, e.g. for a test ride, or permanently for vehicle handover.

i Info

Make sure that the vehicle is permanently enabled before handing it over to the customer.

2.2 Diagnostics connector

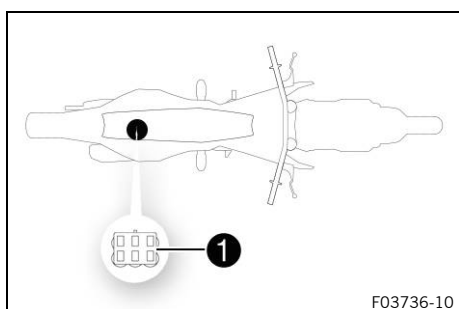

The diagnostics connector **1** is located under the seat below the EFI control unit.

i Info

As soon as the diagnostics tool is connected, the service hour counter starts running.

2.3 Unpacking and setting up the vehicle

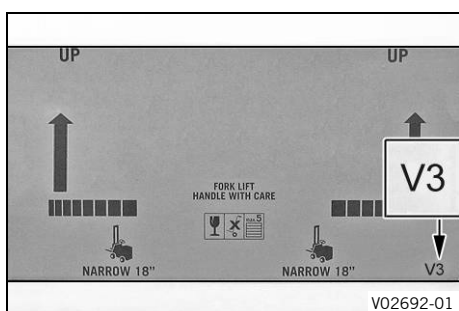

Package 3

- Remove the box and the plastic packaging.

i Info

To avoid damaging the motorcycle during the setup, leave the protective film on the vehicle until you have finished.

- Remove the separate enclosure and unpack it. Check that the scope of supply is complete on the basis of the enclosed packing list.

i Info

The procedure for missing components is described in the Customer Service Manual.

- Carefully loosen and remove the tension belts around the fork legs.
- Remove the attachment on the rear wheel.

i Info

An assistant prevents the motorcycle from falling over.

- Have a lift stand available.

Lift stand (81329955100)

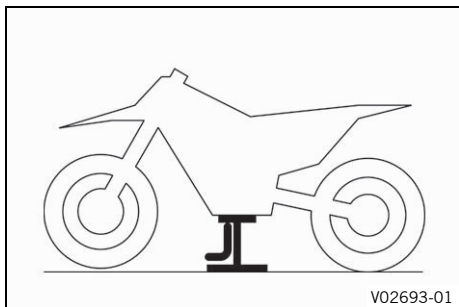

- Together with an assistant, take the vehicle off the pallet.
- Position the vehicle on a lift stand.
- Check the vehicle for transport damage.

i Info
The procedure in the event of transport damage is described in the Customer Service Manual.

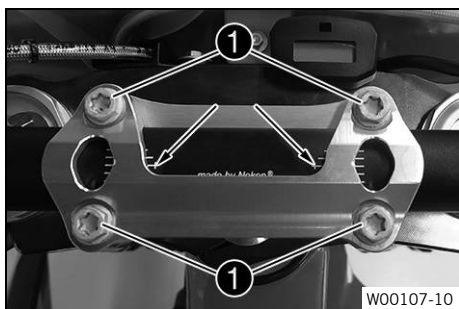

- Remove the cable ties on the side cover and remove the film from the handlebar.

! Warning
Danger of accidents A repaired handlebar poses a safety risk.
If the handlebar is bent or straightened, the material becomes fatigued. The handlebar may break as a result.

- Change the handlebar if the handlebar is damaged or bent.

- Position the handlebar.

i Info
Make sure the cables and wiring are positioned correctly.
Do not kink the cables or lines.

- Position the handlebar clamp.
- Mount screws 1, but do not tighten yet.
- First bolt the handlebar clamp with screws 1 onto the longer, higher side of the handlebar supports so that both parts touch.
- Tighten screws 1 evenly.

Guideline

Screw, handlebar clamp	M8	20 Nm (14.8 lbf ft)
------------------------	----	------------------------

i Info
The markings on the handlebar should be at the center of the handlebar clamps.

- Position the controls on the right half of the handlebar.

Guideline

Screw, throttle grip	M6	5 Nm (3.7 lbf ft)
Screw, start/stop button	EJOT PT® K50x18 T20	2 Nm (1.5 lbf ft)





- Position the controls on the left handlebar half.

Guideline

Screw, fixed grip	M4	5 Nm (3.7 lbf ft) Loctite®243™
Screw, combination switch	EJOT PT® K50x18 T20	2 Nm (1.5 lbf ft)

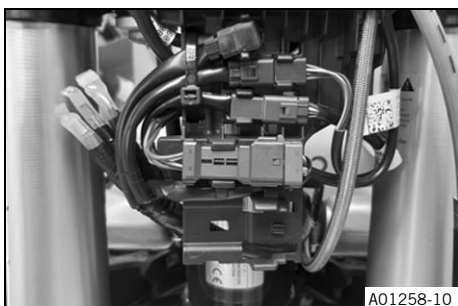

- Remove the start number plate. (📖 p. 12)
- Join all plug-in connectors.
- Route the cables without tension and secure with the cable ties.
- Install the start number plate. (📖 p. 13)

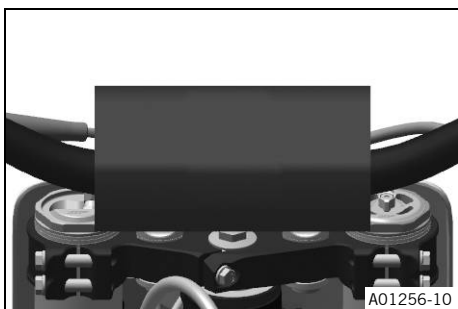

- Mount the handlebar cushion.

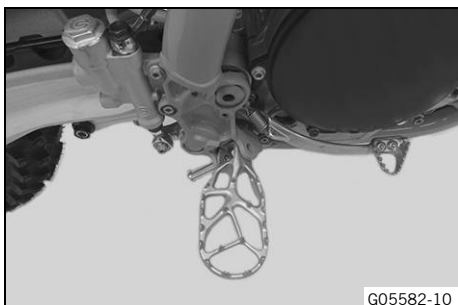

- Position the footrest and pin.

i Info
Only insert the pin to the extent that the spring can still be mounted.

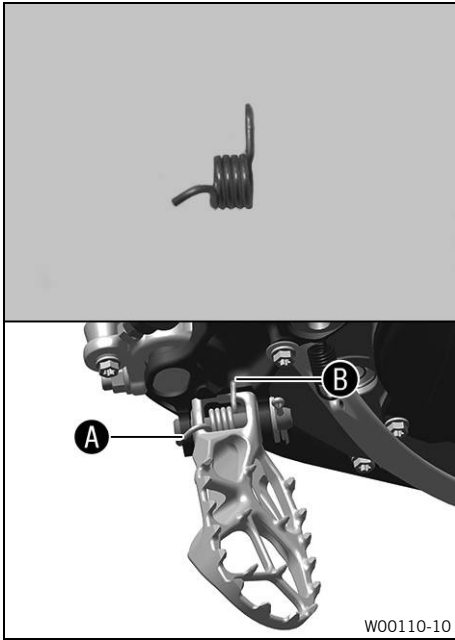

- Position spring as shown.
- ✓ Spring engages in area **A** and **B**.

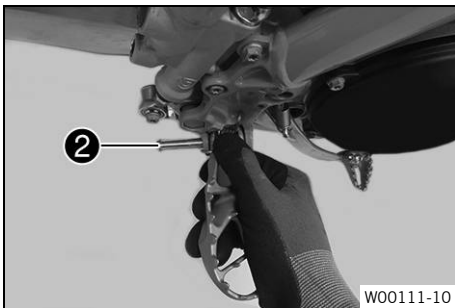

- Apply pressure to the spring with your thumb.
- Mount pin **2**.

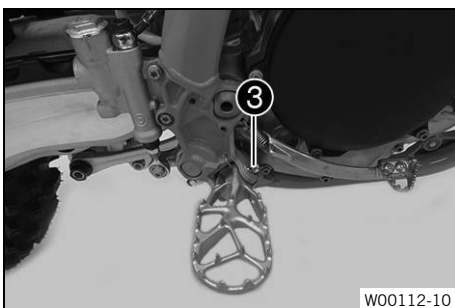

- Mount the washer and splint **3**.
- Repeat these steps on the opposite side.
- Install the frame protector. (📖 p. 10)

(All XC models)

- Install the engine guard. (📖 p. 9)

(All XC models)

- Mount the handguard. (📖 p. 9)

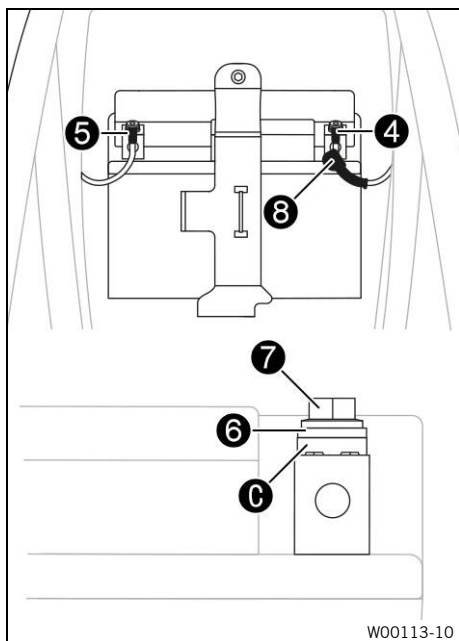

- Remove the seat. (📖 p. 13)
- Connect positive cable 4 to the 12-V battery.

Guideline

Screw, battery terminal	M5	2.5 Nm (1.84 lbf ft)
-------------------------	----	-------------------------

- Connect negative cable 5 to the 12 V battery.

Guideline

Screw, battery terminal	M5	2.5 Nm (1.84 lbf ft)
-------------------------	----	-------------------------

Contact disks 6 must be mounted under screws 6 and cable sockets 7 with the claws toward the battery terminal.

- Slide positive terminal cover 8 over the positive terminal.
- Charge the 12-V battery. (📖 p. 10)

Guideline

The 12-V battery must be fully charged before it is handed over to the customer.



Info

The first charging process may take longer with a new 12-V battery.

- Mount the seat. (📖 p. 14)
- Stick displacement sticker on the left and right of the side cover.
- Attach the stickers included in the scope of supply (optional).
- Unpack and mount the **KTM PowerParts** included in the delivery (optional).



Info

Read the accompanying **KTM PowerParts** fitting instructions.

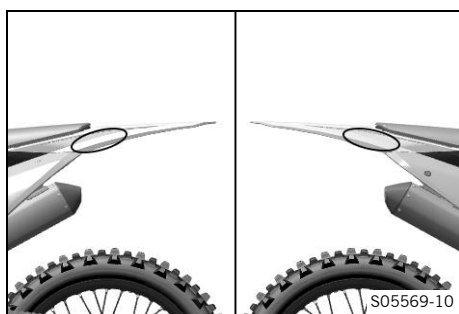

- Refuel. (📖 p. 14)
- Position all controls in their exact positions on the handlebar. Tighten all screws.
- Remove the remaining film, padding, the corrugated cardboard, and the other packaging material.
- Prepare the vehicle according to the specifications in **KTM Dealer.net** for handover to the customer.



Info

Transport mode must be deactivated to be able to start the motorcycle.

3.1 Raising the motorcycle with a lift stand

Note

Material damage The vehicle may be damaged by incorrect procedure when parking.

Significant damage may be caused if the vehicle rolls away or falls over.

The components for parking the vehicle are designed only for the weight of the vehicle.

- Park the vehicle on a firm and level surface.
- Ensure that nobody sits on the vehicle when the vehicle is parked on a stand.

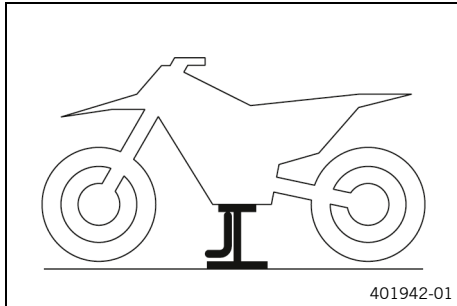

- Raise the motorcycle at the frame underneath the engine.

Lift stand (78129955100)

- ✓ Neither wheel is in contact with the ground.
- Secure the motorcycle against falling over.

3.2 Removing the motorcycle from the lift stand

Note

Material damage The vehicle may be damaged by incorrect procedure when parking.

Significant damage may be caused if the vehicle rolls away or falls over.

The components for parking the vehicle are designed only for the weight of the vehicle.

- Park the vehicle on a firm and level surface.
- Ensure that nobody sits on the vehicle when the vehicle is parked on a stand.

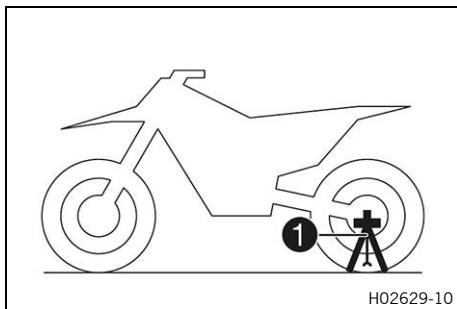

(All SX models)

- Remove the motorcycle from the lift stand.
- Remove the lift stand.
- To park the motorcycle, insert plug-in stand ① into the left side of the wheel spindle.

Plug-in stand (A46029094000)



Info

Remove the plug-in stand before riding.

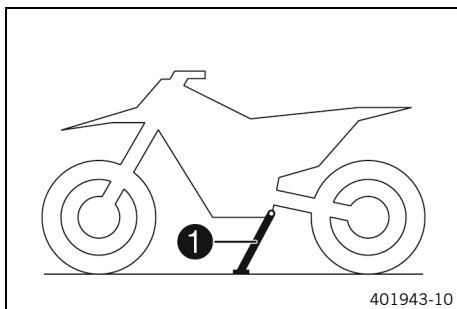

(All XC models)

- Remove the motorcycle from the lift stand.
- Remove the lift stand.
- To park the motorcycle, press side stand ① to the ground with your foot and lean the motorcycle on it.



Info

When you are riding, the side stand must be folded up and secured with the rubber strap.

3.3 Installing the engine guard (All XC models)

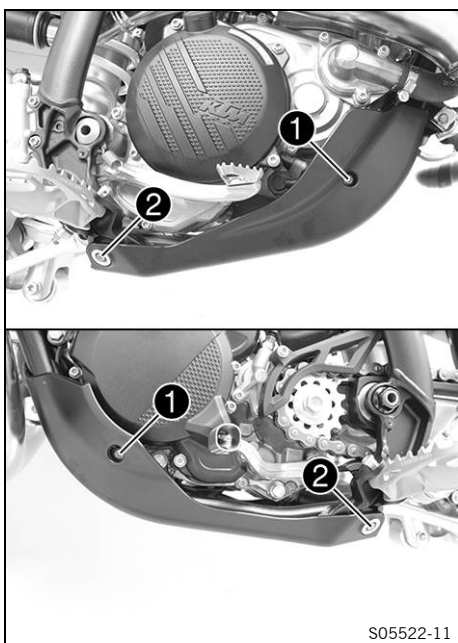

- Position the engine guard on the frame.
- Mount screws ①, but do not tighten yet.

Guideline

Remaining screws, chassis	M6	10 Nm (7.4 lbf ft)
---------------------------	----	--------------------

- Mount screws ② with bushings, but do not tighten yet.

Guideline

Remaining screws, chassis	M6	10 Nm (7.4 lbf ft)
---------------------------	----	--------------------

✓ The engine guard is directed evenly toward the front.

- Tighten all the screws of the engine guard.

Guideline

Remaining screws, chassis	M6	10 Nm (7.4 lbf ft)
---------------------------	----	--------------------

3.4 Mounting the handguard (All XC models)

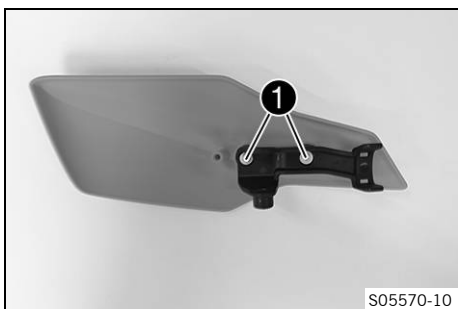

- Mount the handguard holder with screws ① on the handguard shell.

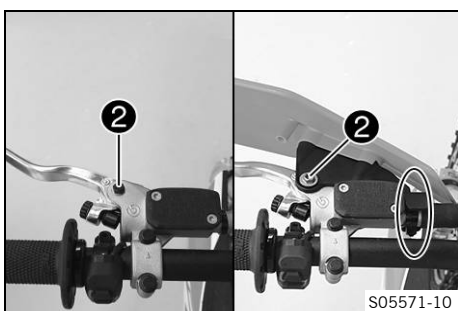

- Pull off the rubber grommet.
- Remove screw ②.
- Position the handguard. Mount and tighten screw ②.

Guideline

Use the included screws for the handguard.

Screw, clutch lever	M6	5 Nm (3.7 lbf ft)
Screw, hand brake lever	M6	5 Nm (3.7 lbf ft)

- Mount the cable ties.
- Repeat the operation on the opposite side.

3.5 Installing the frame protector

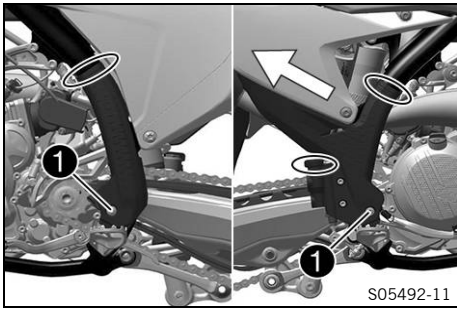

- Position the left frame protector.
- Insert the right frame protector from below and push it to the rear.
- Mount screws ① with the bushings and tighten.

Guideline

Screw, frame protector	M5	3 Nm (2.2 lbf ft)
------------------------	----	-------------------

- Secure the frame protector with cable ties.

3.6 Installing front fender

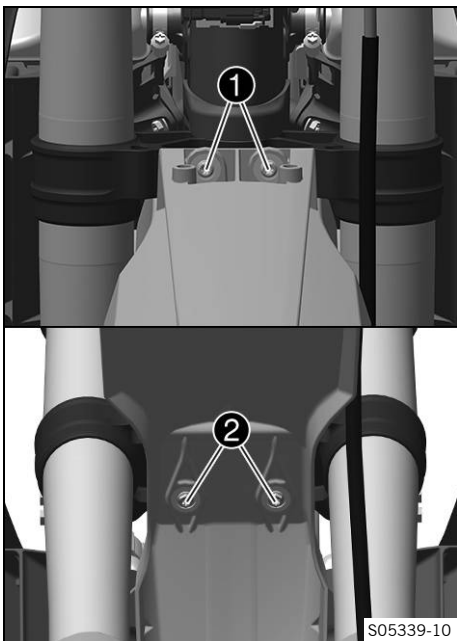

Main work

- Position front fender. Mount and tighten screws ① and ②.

Guideline

Remaining screws, chassis	M6	10 Nm (7.4 lbf ft)
---------------------------	----	--------------------

Finishing work

- Install the start number plate. (📖 p. 13)

3.7 Charging the 12-V battery



Warning

Risk of injury 12 V batteries contain harmful substances.

- Keep 12 V batteries out of the reach of children.
- Keep sparks and open flames away from 12 V batteries.
- Only charge 12 V batteries in well-ventilated rooms.
- Maintain a minimum clearance from inflammable materials when charging 12 V batteries.
Minimum clearance 1 m (3 ft)
- Do not charge deeply discharged 12 V batteries if the charge is already below the minimum voltage.
Minimum voltage before the start of the charge 9 V
- Dispose of 12 V batteries correctly if they have less than the minimum voltage.

Note

Danger of damage An incorrectly selected charging mode will damage the 12-V battery.

- Always select a charging mode that is compatible with the type of battery.



Note

Environmental hazard 12 V batteries contain environmentally hazardous materials.

- Do not dispose of 12 V batteries as household waste.
- Dispose of 12 V batteries at a collection point for used batteries.



Note

Environmental hazard Hazardous substances cause environmental damage.

- Dispose of oils, grease, filters, fuel, cleaning agents, brake fluid, etc., correctly and in compliance with the applicable regulations.



Info

Even when there is no load on the 12-V battery, it discharges steadily each day.

The charging level and the method of charging are very important for the service life of the 12-V battery.

Rapid recharging with a high charging current shortens the service life of the battery.

If the charging current, charging voltage, or charging time is exceeded, the 12-V battery will be destroyed.

If the 12-V battery is discharged by repeated starting, charge the 12-V battery immediately.

If the 12-V battery is left in a discharged state for an extended period, it will become deeply discharged and suffer a loss of capacity, destroying the battery.

The 12-V battery is maintenance-free.

Preparatory work

- Remove the seat. (📖 p. 13)
- Disconnect the negative cable of the 12-V battery. (📖 p. 12)

Main work

- Connect a battery charger to the 12-V battery. Adjust the battery charger.

EU battery charger **XCharge-professional** (00029095050)

Alternative 1

US battery charger **XCharge-professional**
(00029095051)

Alternative 2

UK battery charger **XCharge-professional**
(00029095052)

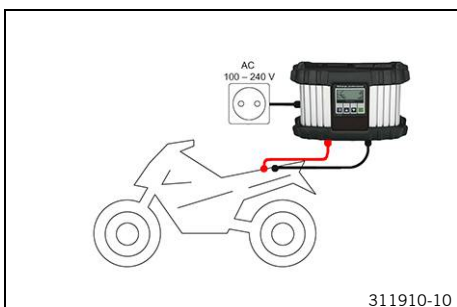

Info

Follow the instructions of the charger and the manual.

- Disconnect the battery charger after charging the 12-V battery.

Guideline

The charging current, charging voltage, and charging time must not be exceeded.

Recharge the 12-V battery regularly when the motorcycle is not being used	6 months
---	----------

Finishing work

- Connect the negative cable of the 12 V battery. (📖 p. 12)
- Mount the seat. (📖 p. 14)

3.8 Disconnecting the negative cable of the 12-V battery

Preparatory work

- Remove the seat. (📖 p. 13)

Main work

- Disconnect negative cable ❶ of the 12-V battery.

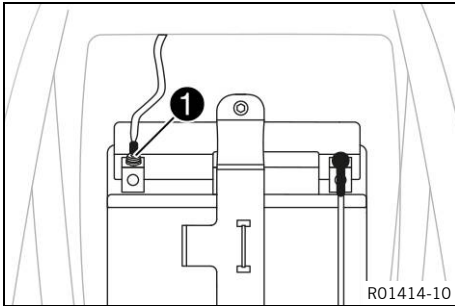

3.9 Connecting the negative cable of the 12 V battery

Main work

- Connect negative cable ❶ of the 12 V battery.

Guideline

Screw, battery terminal	M5	2.5 Nm (1.84 lbf ft)
-------------------------	----	-------------------------

Contact disks **A** must be mounted under the screw **❷** and the cable lug **❸** with the claws toward the battery terminal.

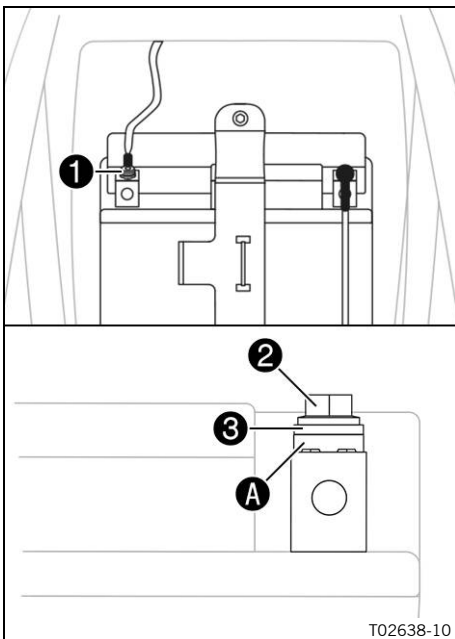

Finishing work

- Mount the seat. (📖 p. 14)

3.10 Removing the start number plate

- Remove screw ❶.
- Unhook the start number plate from the brake line and remove it.

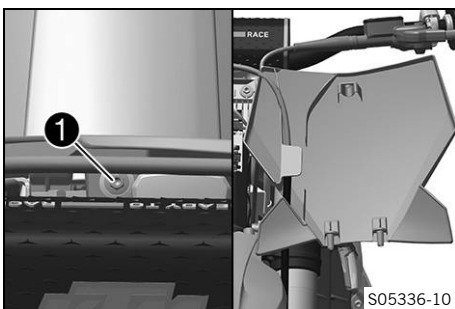

3.11 Installing the start number plate

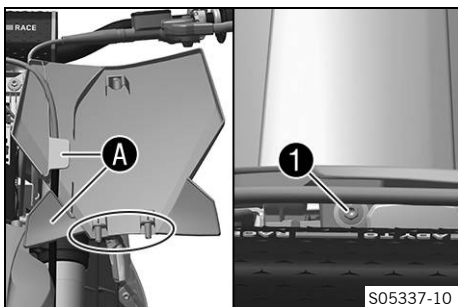

- Position the brake line in holders **A** on the start number plate.
 - Position the start number plate. Mount and tighten screw **1**.
- Guideline

Remaining screws, chassis	EJOT PT K60x25	2 Nm (1.5 lbf ft)
---------------------------	--------------------------	-------------------

- ✓ The holding lugs engage in the fender.

3.12 Removing the seat

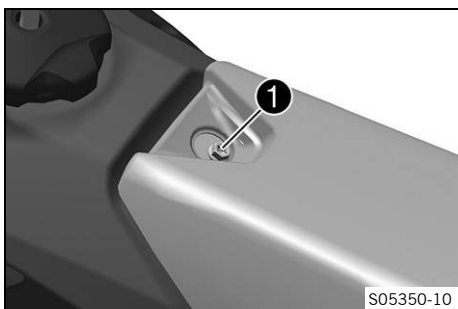

- Remove screw **1**.

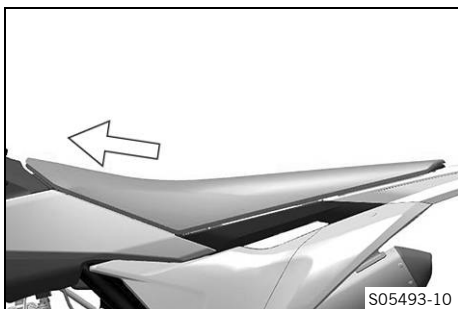

- Raise seat, pull it toward the fuel tank and take it off.

3.13 Mounting the seat

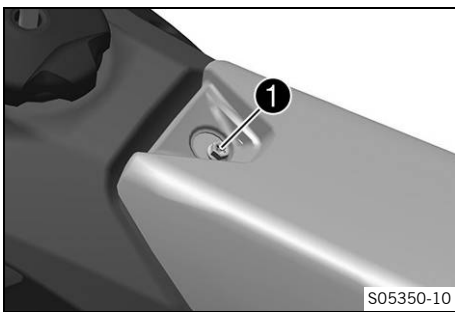
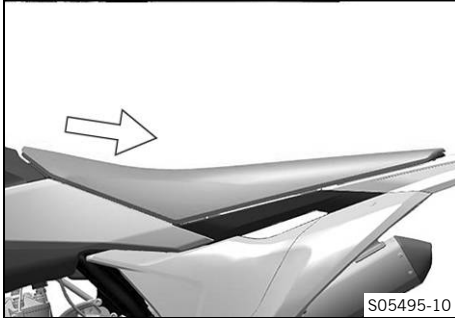
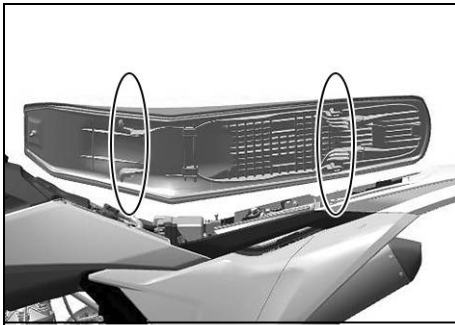

- Attach the seat to the collar bushings at the front and simultaneously push it back.
- ✓ The holding lugs engage in the recesses at the back.
- Make sure the seat is latched in place correctly.

- Mount and tighten screw ①.

Guideline

Remaining screws, chassis	M6	10 Nm (7.4 lbf ft)
---------------------------	----	--------------------

3.14 Refueling



Danger

Fire hazard Fuel is highly flammable.

The fuel in the fuel tank expands when warm and can escape if overfilled.

- Do not fuel the vehicle in the vicinity of open flames or lit cigarettes.
- Switch off the engine for refueling.
- Make sure that no fuel is spilled; particularly not on hot parts of the vehicle.
- If any fuel is spilled, wipe it off immediately.
- Observe the specifications for refueling.



Warning

Danger of poisoning Fuel is harmful to health.

- Avoid skin, eye and clothing contact with fuel.
- Immediately consult a doctor if you swallow fuel.
- Do not inhale fuel vapors.
- Rinse the affected area immediately with plenty of water in the event of contact with the skin.
- Rinse the eyes thoroughly with water, and consult a doctor in case of fuel contact with the eyes.
- Change your clothing if fuel spills on them.



Note

Environmental hazard Improper handling of fuel is a danger to the environment.

- Do not allow fuel to enter the groundwater, the soil, or the sewage system.

- Switch off the engine.
- Open fuel tank filler cap. (📖 p. 15)
- Fill the fuel tank with fuel up to measurement **A**.

Guideline

Measurement of A	35 mm (1.38 in)	
Total fuel tank capacity, approx. (All SX models)	7.2 l (1.9 US gal)	Super unleaded (95 octane) mixed with 2-stroke engine oil (1:60) (📖 p. 21)
Total fuel tank capacity, approx. (All XC models)	8.5 l (2.25 US gal)	Super unleaded (95 octane) mixed with 2-stroke engine oil (1:60) (📖 p. 21)
Engine oil, 2-stroke (📖 p. 21)		

- Close the fuel tank filler cap. (📖 p. 16)

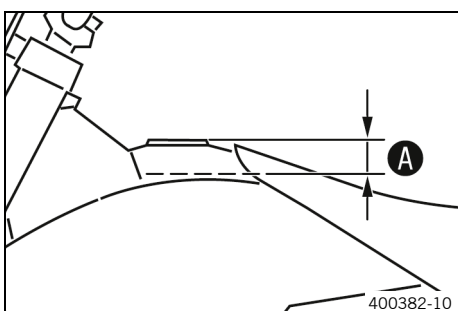

3.15 Opening fuel tank filler cap



Danger

Fire hazard Fuel is highly flammable.

The fuel in the fuel tank expands when warm and can escape if overfilled.

- Do not fuel the vehicle in the vicinity of open flames or lit cigarettes.
- Switch off the engine for refueling.
- Make sure that no fuel is spilled; particularly not on hot parts of the vehicle.
- If any fuel is spilled, wipe it off immediately.
- Observe the specifications for refueling.



Warning

Danger of poisoning Fuel is harmful to health.

- Avoid skin, eye and clothing contact with fuel.
- Immediately consult a doctor if you swallow fuel.
- Do not inhale fuel vapors.
- Rinse the affected area immediately with plenty of water in the event of contact with the skin.
- Rinse the eyes thoroughly with water, and consult a doctor in case of fuel contact with the eyes.
- Change your clothing if fuel spills on them.
- Keep fuels correctly in a suitable canister, and out of the reach of children.



Note

Environmental hazard Improper handling of fuel is a danger to the environment.

- Do not allow fuel to enter the groundwater, the soil, or the sewage system.

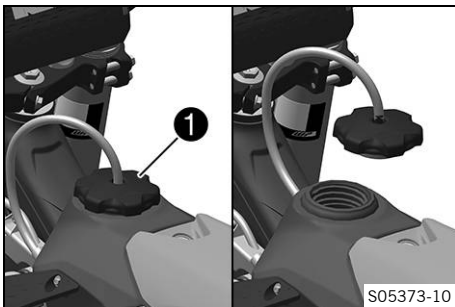

(All SX models)

- Turn fuel tank filler cap ❶ counterclockwise and lift it off.

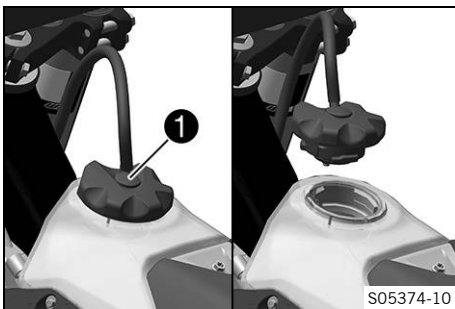

(All XC models)

- Press release button ❶, turn the fuel tank filler cap counterclockwise, and lift it off.

3.16 Closing the fuel tank filler cap

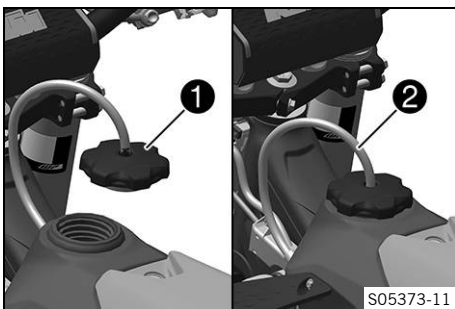

(All SX models)

- Mount fuel tank filler cap ❶ and turn it clockwise until the fuel tank is tightly closed.



Info

Route fuel tank breather hose ❷ without kinks.

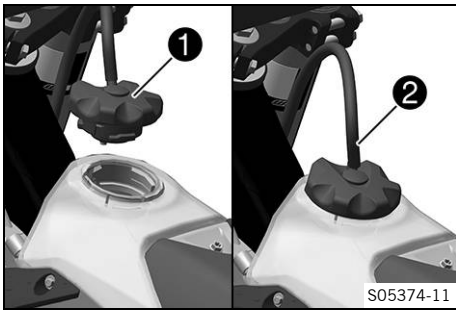

(All XC models)

- Mount filler cap ① and turn it clockwise until the release button engages.



Info

Route fuel tank breather hose ② without kinks.



4 TECHNICAL SPECIFICATIONS

4.1 chassis tightening torques

Hose clamp, radiator		2.4 Nm (1.77 lbf ft)
Hose clip, inlet sleeve to throttle valve body		2.8 Nm (2.07 lbf ft)
Screw, air filter box, on subframe	EJOT PT® K60x20AL	5 Nm (3.7 lbf ft)
Screw, combination switch	EJOT PT® K50x18 T20	2 Nm (1.5 lbf ft)
Screw, fuel pump on fuel tank	EJOT PT® K60x25-Z	2.5 Nm (1.84 lbf ft)
Screw, intake air temperature sensor	EJOT PT® K50x18 T20	0.7 Nm (0.52 lbf ft)
Screw, seat fixing	EJOT EJOFORM PT® K60x23/18	2.5 Nm (1.84 lbf ft)
Screw, stop button	EJOT PT K50x18 T20	2 Nm (1.5 lbf ft)
Screw, fixed grip	M4	5 Nm (3.7 lbf ft) Loctite®243™
Screw, hose clip, throttle valve body	M4	5 Nm (3.7 lbf ft)
Spoke nipple, front wheel	M4.5	6 Nm (4.4 lbf ft)
Spoke nipple, rear wheel	M4.5	6 Nm (4.4 lbf ft)
Remaining nuts, chassis	M5	5 Nm (3.7 lbf ft)
Remaining screws, chassis	M5	5 Nm (3.7 lbf ft)
Screw, battery terminal	M5	2.5 Nm (1.84 lbf ft)
Screw, frame protector	M5	3 Nm (2.2 lbf ft)
Screw, shock absorber adjusting ring	M5	5 Nm (3.7 lbf ft)
Screw, throttle valve body cover	M5	2.6 Nm (1.92 lbf ft)
Screws on main silencer	M5	7 Nm (5.2 lbf ft)
Nut, cable on starter motor	M6	4 Nm (3 lbf ft)
Nut, throttle cable on throttle valve body	M6	3 Nm (2.2 lbf ft)
Remaining nuts, chassis	M6	10 Nm (7.4 lbf ft)
Remaining screws, chassis	M6	10 Nm (7.4 lbf ft)
Screw, battery cable to starter relay	M6x16	6 Nm (4.4 lbf ft)
Screw, battery holding bracket	M6	6 Nm (4.4 lbf ft)
Screw, brake disc, front	M6	14 Nm (10.3 lbf ft) Loctite®243™
Screw, brake line guide on link fork	M6	4.5 Nm (3.32 lbf ft) Loctite®243™
Screw, chain guide on link fork at the front	M6	10 Nm (7.4 lbf ft)
Screw, chain guide on link fork at the rear	M6	10 Nm (7.4 lbf ft) Loctite®243™
Screw, chain sliding guard	M6	6 Nm (4.4 lbf ft) Loctite®243™
Screw, clutch lever	M6	5 Nm (3.7 lbf ft)
Screw, connector board with combination instrument	M6	5 Nm (3.7 lbf ft)
Screw, fender to triple clamp	M6	12 Nm (8.9 lbf ft)
Screw, fuel tank spoiler on radiator	M6	6 Nm (4.4 lbf ft)

Screw, ground wire on frame	M6	10 Nm (7.4 lbf ft)
Screw, hand brake lever	M6	5 Nm (3.7 lbf ft)
Screw, push rod ball joint on the brake cylinder of the rear brake system	M6	10 Nm (7.4 lbf ft) Loctite®243™
Screw, rear brake disc	M6	14 Nm (10.3 lbf ft) Loctite®243™
Screw, seat fixing	M6	8 Nm (5.9 lbf ft)
Screw, starter cable to starter relay	M6x8	6 Nm (4.4 lbf ft)
Screw, throttle grip	M6	5 Nm (3.7 lbf ft)
Nut, foot brake lever stop	M8	20 Nm (14.8 lbf ft)
Nut, rear sprocket screw	M8	35 Nm (25.8 lbf ft) Loctite®2701™
Nut, rim lock	M8	12 Nm (8.9 lbf ft)
Remaining nuts, chassis	M8	25 Nm (18.4 lbf ft)
Remaining screws, chassis	M8	25 Nm (18.4 lbf ft)
Screw, bottom triple clamp	M8	12 Nm (8.9 lbf ft)
Screw, chain sliding piece	M8	15 Nm (11.1 lbf ft)
Screw, engine sprocket cover on frame	M8	15 Nm (11.1 lbf ft)
Screw, fork shoe	M8	15 Nm (11.1 lbf ft)
Screw, front brake caliper	M8	25 Nm (18.4 lbf ft) Loctite®243™
Screw, handlebar clamp	M8	20 Nm (14.8 lbf ft)
Screw, manifold	M8	15 Nm (11.1 lbf ft)
Screw, side stand fixing (All XC models)	M8	33 Nm (24.3 lbf ft) Loctite®2701™
Screw, subframe bottom	M8x18	30 Nm (22.1 lbf ft) Loctite®2701™
Screw, subframe, top	M8x15	35 Nm (25.8 lbf ft) Loctite®243™
Screw, top steering stem	M8	20 Nm (14.8 lbf ft) Loctite®243™
Screw, top triple clamp	M8	17 Nm (12.5 lbf ft)
Engine bracket screw	M10	60 Nm (44.3 lbf ft)
Remaining nuts, chassis	M10	45 Nm (33.2 lbf ft)
Remaining screws, chassis	M10	45 Nm (33.2 lbf ft)
Screw, bottom shock absorber	M10	60 Nm (44.3 lbf ft) Loctite®2701™
Screw, handlebar support	M10	40 Nm (29.5 lbf ft) Loctite®243™
Screw, top shock absorber	M10	60 Nm (44.3 lbf ft) Loctite®2701™
Coolant temperature sensor	M10x1.25	10 Nm (7.4 lbf ft)
Nut, angle lever to link fork	M14x1.5	60 Nm (44.3 lbf ft)
Nut, frame on linkage lever	M14x1.5	60 Nm (44.3 lbf ft)
Nut, linkage lever on angle lever	M16x1.5	60 Nm (44.3 lbf ft)
Nut, swingarm pivot	M16x1.5	100 Nm (73.8 lbf ft)

4 TECHNICAL SPECIFICATIONS

Screw, steering head, top	M20x1.5	12 Nm (8.9 lbf ft)
Screw, wheel spindle, front	M20x1.5	35 Nm (25.8 lbf ft)
Nut, wheel spindle, rear	M22x1.5	80 Nm (59 lbf ft)
Screw-in fitting, cooling system	M24x1.5	7.5 Nm (5.53 lbf ft)

Engine oil, 2-stroke

Standard/classification

- JASO FD (📖 p. 22)

Guideline

- Only use high-grade 2-stroke engine oil from a reputable brand.

fully synthetic

Recommended supplier

MOTOREX®

- Cross Power 2T

Super unleaded (ROZ 95)

Standard/classification

- DIN EN 228 (ROZ 95)

Guideline

- Only use super unleaded fuel that matches or is equivalent to the specified standard.
- Fuel with an ethanol content of up to 10% (E10 fuel) is safe to use.



Info

Do **not** use fuel containing methanol (e.g., M15, M85, M100) or more than 10% ethanol (e.g., E15, E25, E85, E100).

Super unleaded (95 octane) mixed with 2-stroke engine oil (1:60)

Standard/classification

- DIN EN 228
- JASO FD (📖 p. 22) (1:60)

Mixture ratio

1:60	Engine oil, 2-stroke (📖 p. 21) Super unleaded (ROZ 95) (📖 p. 21)
------	---

Recommended supplier

MOTOREX®

- Cross Power 2T

JASO FD

JASO FD is a classification for a 2-stroke engine oil that was specifically developed for the extreme demands of racing. Thanks to first-rate synthetic esters and specially designed additives, superb combustion is achieved even under extreme operating conditions.



3240089en

08.05.2024

