

INFODESK 2025

READY   
TO RACE

250 SX  
300 SX  
250 XC  
300 XC

ITEM NO. 3240108EN



**KTM**



This manual was written on the basis of the latest information for this model series. We reserve the right to make changes in the interest of technical advancement without at the same time updating this manual.

We shall not provide a description of general workshop methods. Likewise, safety rules that apply in a workshop are not specified here. It is assumed that the work will be performed by a fully trained mechanic.

All specifications contained herein are non-binding. KTM Sportmotorcycle GmbH specifically reserves the right to modify or delete technical specifications, prices, colors, forms, materials, services, designs, equipment, etc., without prior notice and without specifying reasons, to adapt these to local conditions, as well as to stop production of a particular model without prior notice. KTM accepts no liability for delivery options, deviations from figures and descriptions, misprints, and other errors. The models portrayed partly contain special equipment that does not belong to the regular scope of supply.

© 2024 KTM Sportmotorcycle GmbH, Mattighofen Austria

All rights reserved

Reproduction, even in part, as well as copying of all kinds, is permitted only with the express written permission of the copyright owner.



ISO 9001(12 100 6061)

KTM applies quality assurance processes that lead to the highest possible product quality as defined in the ISO 9001 international quality management standard.

Issued by: TÜV SÜD Management Service GmbH

REG.NO. 12 100 6061

KTM Sportmotorcycle GmbH

Stallhofnerstraße 3

5230 Mattighofen, Austria

This document is valid for the following models:

250 SX (F6301Y0)

300 SX (F6401Y1)

250 XC (F6375Y5)

300 XC (F6475Y5)











1	MEANS OF REPRESENTATION .....	3	7	CONNECTOR OVERVIEW .....	152
1.1	Symbols used .....	3	7.1	Tilt sensor connector AM .....	152
1.2	Formats used.....	3	7.2	Diagnostics connector AP .....	152
2	ENGINE MANAGEMENT SYSTEM COMPONENTS.....	4	7.3	Tilt sensor connector AR.....	152
2.1	Overview of the engine management system .....	4	7.4	Capacitor connector AS .....	152
2.2	Combination instrument .....	5	7.5	Crankshaft speed sensor connector AT .....	153
2.3	Overview of indicator lamps (All SX models).....	5	7.6	Ignition coil connector AW.....	153
2.4	Overview of indicator lights (All XC models).....	5	7.7	Intake air temperature sensor connector CM .....	153
2.5	Fuel pump (All XC models) .....	5	7.8	Voltage regulator connector EE.....	153
2.6	Fuel pump (All SX models) .....	6	7.9	Voltage regulator connector EY.....	154
2.7	Overview of relays .....	7	7.10	Voltage regulator connector EZ.....	154
2.8	Voltage regulator .....	7	7.11	Throttle valve position sensor circuit A,connector FT .....	154
2.9	Capacitor .....	8	7.12	Fuel pump, connector GA (All SX models).....	154
2.10	12-V battery .....	8	7.13	Fuel pump, connector GA (All XC models).....	155
2.11	Starting power of lithium-ion batteries at low temperatures.....	8	7.14	Injection valve 1, cylinder 1, connector GQ .....	155
2.12	Coolant temperature sensor.....	9	7.15	Injection valve 2, cylinder 1, connector GQ .....	155
2.13	Crankshaft speed sensor .....	10	7.16	Coolant temperature sensor connector HV.....	155
2.14	Ignition coil.....	11	7.17	Crankshaft speed sensor connector IF.....	156
2.15	Dwell .....	11	7.18	Ambient air pressure sensor connector LU.....	156
2.16	Ignition point.....	12	7.19	Crankcase pressure sensor connector LU.....	156
2.17	Crankcase pressure sensor .....	12	7.20	Connectivity Unit connector OJ .....	156
2.18	Intake air temperature sensor.....	12	7.21	Exhaust control actuator ON.....	157
2.19	Injection valves, cylinder 1 .....	13	7.22	Map select switch connector QZ .....	157
2.20	Circuit A throttle valve position sensor.....	14	7.23	Engine control unit connector RP ...	157
2.21	Ambient air pressure sensor .....	15	8	SPECIAL TOOLS .....	159
2.22	Tilt sensor .....	15	9	GLOSSARY OF TECHNICAL TERMS.....	164
2.23	Engine control unit.....	16	10	LIST OF ABBREVIATIONS.....	165
2.24	Diagnostics connector .....	16		INDEX.....	166
2.25	Exhaust control actuator .....	17			
2.26	Connectivity Unit .....	17			
3	ENGINE CONTROL TROUBLE CODE.....	18			
4	TROUBLE CODE, CONNECTIVITY UNIT .....	118			
5	ACTUATOR TEST .....	141			
5.1	Injection valve 1 function .....	141			
5.2	Injection valve 2 function .....	141			
5.3	Function of ignition coil.....	141			
5.4	Fuel pump operation .....	142			
5.5	Function of the exhaust control actuator .....	142			
6	WIRING DIAGRAM .....	144			
6.1	Page 1 of 4 .....	144			
6.2	Page 2 of 4 .....	146			
6.3	Page 3 of 4 .....	148			
6.4	Page 4 of 4 .....	150			

## 1.1 Symbols used

The meaning of specific symbols is described below.

---

	Indicates an expected reaction (e.g. of a work step or a function).
	Indicates an unexpected reaction (e.g. of a work step or a function).
	Indicates a page reference (more information is provided on the specified page).
	Indicates information with more details or tips.
	Indicates the result of a testing step.
	Indicates a voltage measurement.
	Indicates a current measurement.
	Indicates a resistance measurement.
	Indicates the end of an activity including potential rework.

---

## 1.2 Formats used

The typographical formats used in this document are explained below.

---

<b>Proprietary name</b>	Indicates a proprietary name.
<b>Name<sup>®</sup></b>	Indicates a protected name.
<b>Brand<sup>™</sup></b>	Indicates a brand available on the open market.
<b><u>Underlined terms</u></b>	Refer to technical details of the vehicle or indicate technical terms, which are explained in the glossary.

---

## 2 ENGINE MANAGEMENT SYSTEM COMPONENTS

### 2.1 Overview of the engine management system

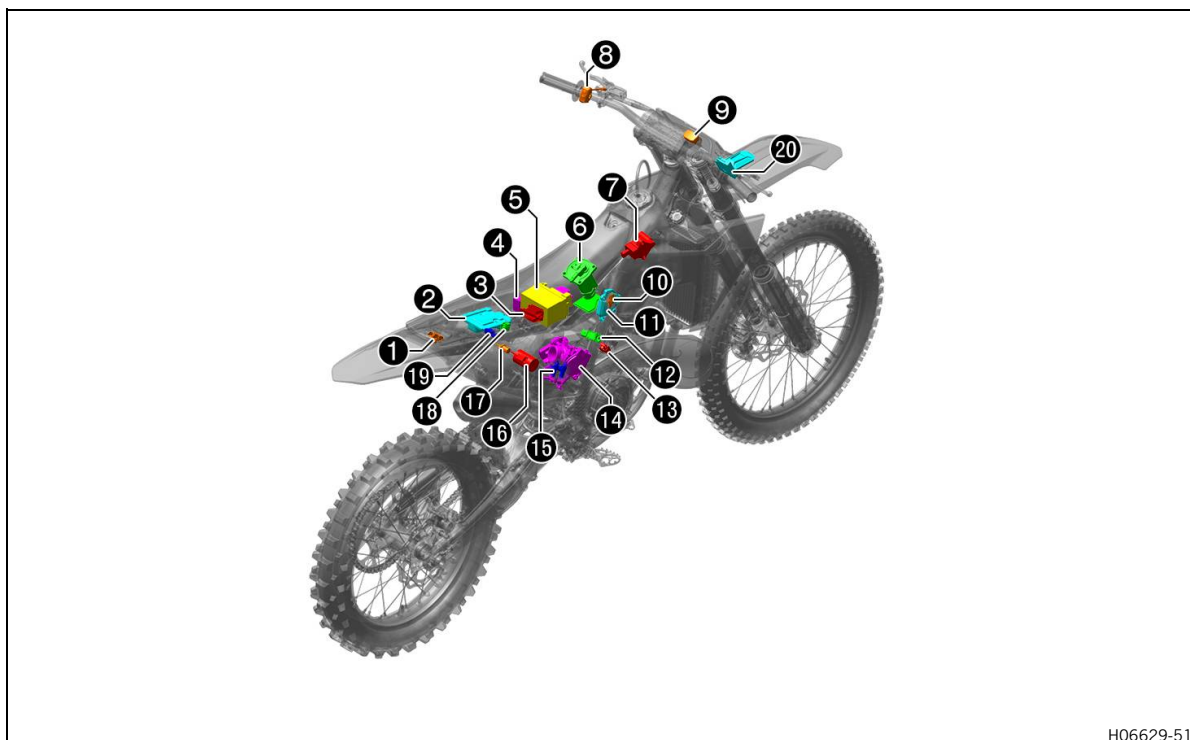

H06629-51

- ❶ Ambient air pressure sensor (📖 p. 15)
- ❷ Engine control unit (📖 p. 16)
- ❸ Voltage regulator (📖 p. 7)
- ❹ Overview of relays (📖 p. 7)
- ❺ 12-V battery (📖 p. 8)
- ❻ Fuel pump (📖 p. 6) **(All SX models)**
- ❻ Fuel pump (📖 p. 5) **(All XC models)**
- ❼ Ignition coil (📖 p. 11)
- ❽ Combination switch, left
- ❾ Overview of indicator lamps (📖 p. 5) **(All SX models)**
- ❾ Overview of indicator lights (📖 p. 5) **(All XC models)**
- ❿ Coolant temperature sensor (📖 p. 9)
- ⓫ Exhaust control actuator (📖 p. 17)
- ⓬ Crankcase pressure sensor (📖 p. 12)
- ⓭ Crankshaft speed sensor (📖 p. 10)
- ⓮ Circuit A throttle valve position sensor (📖 p. 14)
- ⓯ Injection valves, cylinder 1 (📖 p. 13)
- ⓰ Capacitor (📖 p. 8)
- ⓱ Intake air temperature sensor (📖 p. 12)
- ⓲ Diagnostics connector (📖 p. 16)
- ⓳ Tilt sensor (📖 p. 15)
- ⓴ Connectivity Unit (📖 p. 17)

## 2.2 Combination instrument

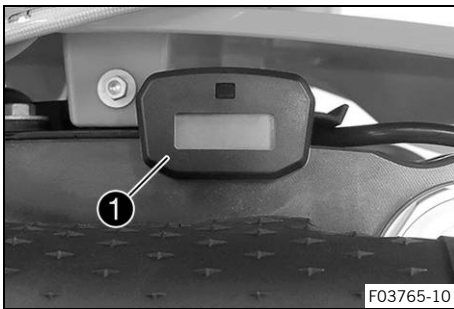

The combination instrument ① is attached in front of the handlebar.

The combination instrument shows the total number of operating hours of the engine.

The operating hour counter begins counting when the engine is started and stops when the engine is switched off.

### **i** Info

Nothing can be cleared or adjusted on the combination instrument.

As soon as the diagnostics tool is connected, the service hour counter starts running.

Before longer diagnostic sessions, unplug the service hour counter behind the start number plate.

## 2.3 Overview of indicator lamps (All SX models)

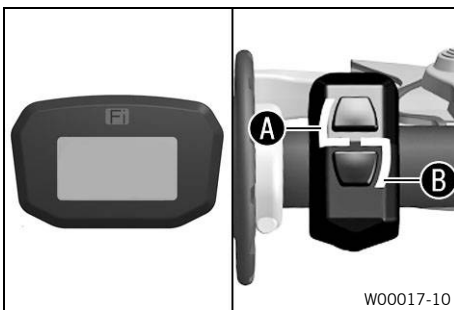

### Possible states

<b>Fi</b>	Malfunction indicator lamp lights up/flashes orange – The <u>OBD</u> has detected a malfunction in the vehicle electronics.
<b>L</b>	Indicator lamp <b>A</b> lights up white – STANDARD mapping is activated.
<b>7</b>	Indicator lamp <b>B</b> lights up green – ADVANCED mapping is activated.

## 2.4 Overview of indicator lights (All XC models)

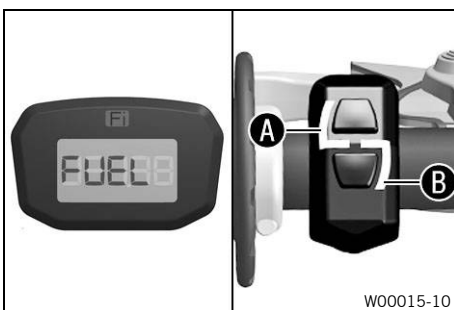

### Possible states

<b>Fi</b>	Malfunction indicator lamp lights up/flashes orange – The <u>OBD</u> has detected a malfunction in the vehicle electronics.
<b>L</b>	Indicator lamp <b>A</b> lights up white – STANDARD mapping is activated.
<b>7</b>	Indicator lamp <b>B</b> lights up green – ADVANCED mapping is activated.
<b>EEEE</b>	<b>FUEL</b> is displayed – The fuel level has reached the reserve mark.

## 2.5 Fuel pump (All XC models)

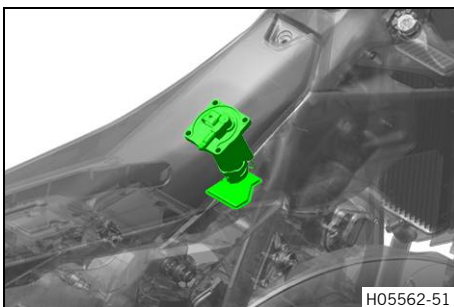

### Installation location

- The fuel pump is located inside the fuel tank.

## 2 ENGINE MANAGEMENT SYSTEM COMPONENTS

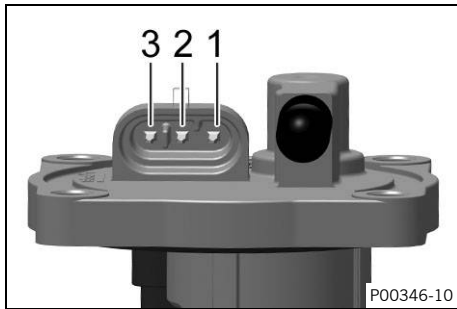

### Pin overview

1	Signal wire, fuel level sensor
2	Control wire
3	Power supply

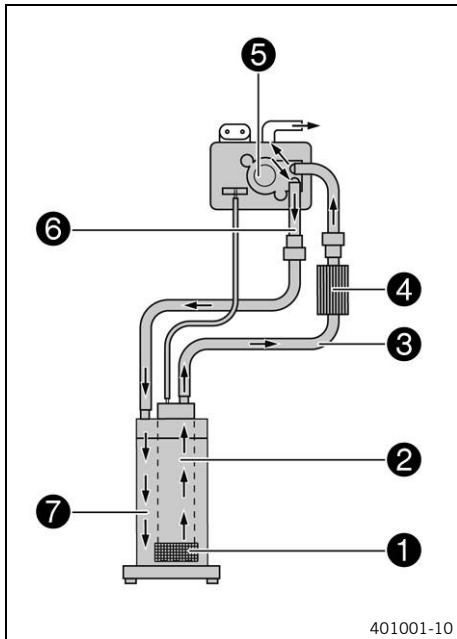

### Functional description

- The fuel passes through the fuel screen **1** before entering the electrically driven vane pump **2**. This delivers the fuel via the fuel line **3** and the fuel filter **4** and on into the pressure regulator **5**. The pressure regulator ensures an even fuel pressure under all load conditions. Excess fuel flows back via hose **6** into pump housing **7**.

### Fuel pressure

When the fuel pump is active	3.3 ... 3.7 bar (48 ... 54 psi)
------------------------------	---------------------------------

### 2.6 Fuel pump (All SX models)

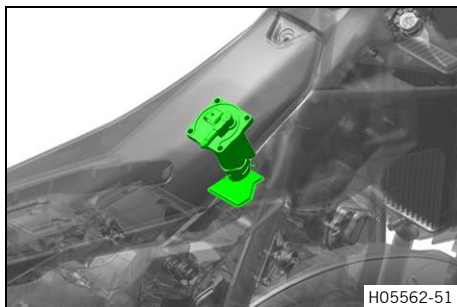

### Installation location

- The fuel pump is located inside the fuel tank.

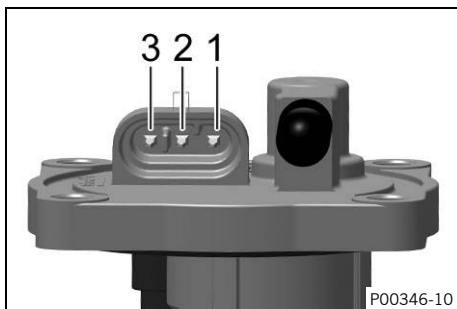

### Pin overview

1	Not assigned
2	Control wire
3	Power supply

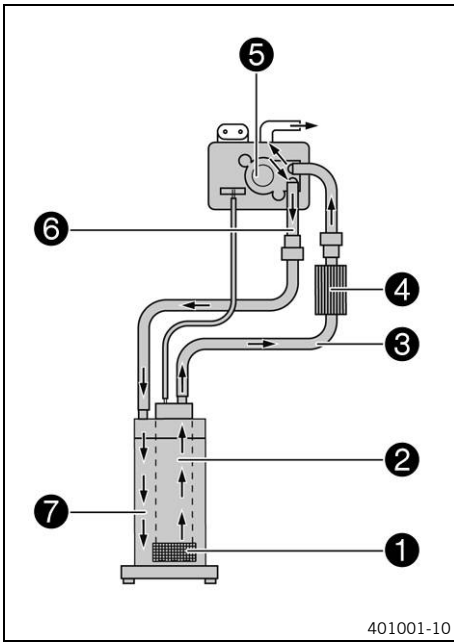

### Functional description

- The fuel passes through the fuel screen **1** before entering the electrically driven vane pump **2**. This delivers the fuel via the fuel line **3** and the fuel filter **4** and on into the pressure regulator **5**. The pressure regulator ensures an even fuel pressure under all load conditions. Excess fuel flows back via hose **6** into pump housing **7**.

#### Fuel pressure

When the fuel pump is active	3.3 ... 3.7 bar (48 ... 54 psi)
------------------------------	---------------------------------

## 2.7 Overview of relays

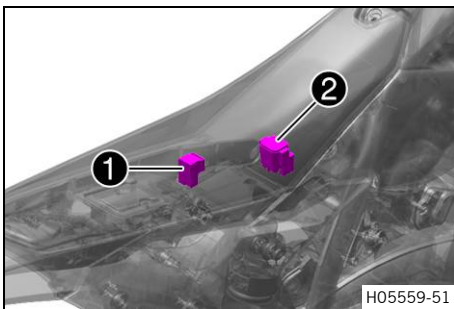

### Overview of relays

- 1** Power relay
- 2** Starter relay with main fuse

## 2.8 Voltage regulator

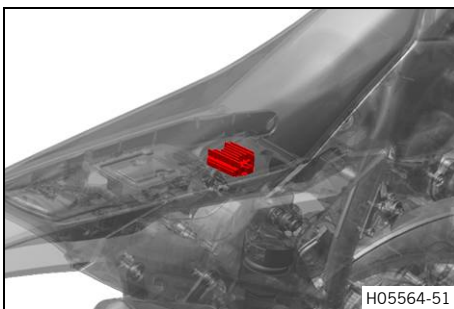

### Installation location

- The voltage regulator is located under the seat.

Voltage regulator connector **EY** (📖 p. 154) pin assignment

Voltage regulator connector **EE** (📖 p. 153) pin assignment

## 2.9 Capacitor

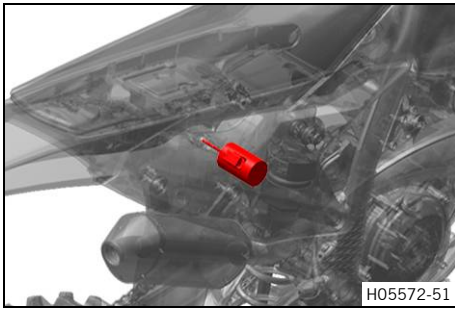

### Installation location

- The capacitor is located in the air filter box.

### Component description

- The capacitor stabilizes the power supply of the engine control unit.

Capacitor connector **AS** (📖 p. 152) pin assignment

## 2.10 12-V battery

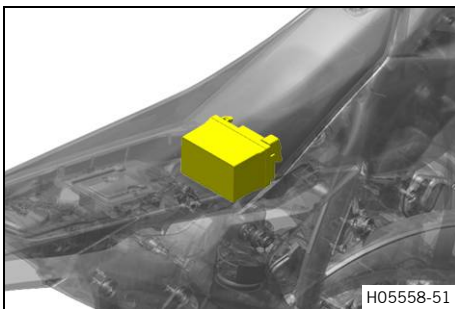

### Installation location

- The 12-V battery is located under the seat.

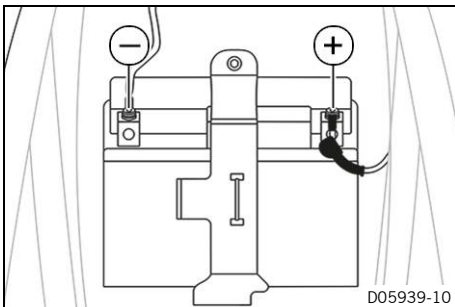

### Measuring point overview

Ground (-)

plus (+)

## 2.11 Starting power of lithium-ion batteries at low temperatures

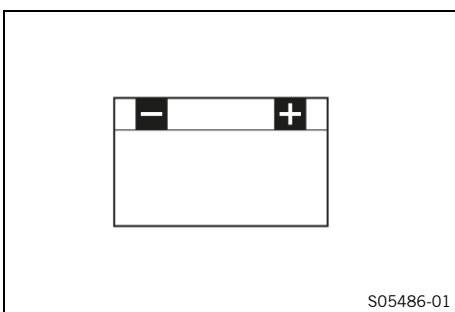

Lithium-ion batteries are far lighter than lead batteries, have a low self-discharge rate, and have more starting power at temperatures over 15 °C (60 °F). At low temperatures, however, the starting power of lithium-ion batteries drops to below that of lead batteries.

Multiple starting attempts may be needed. Press the start button for 5 seconds, and wait 30 seconds between attempts. The pauses are necessary so that the heat created can distribute through the lithium-ion battery and the lithium-ion battery is not damaged.

If the charged lithium-ion battery is unable to actuate the starter motor or does so only weakly when temperatures are below 15 °C (60 °F), the battery is not faulty but needs to be warmed up internally to increase its starting power (current output).

The starting power increases as the battery warms up.

## 2.12 Coolant temperature sensor

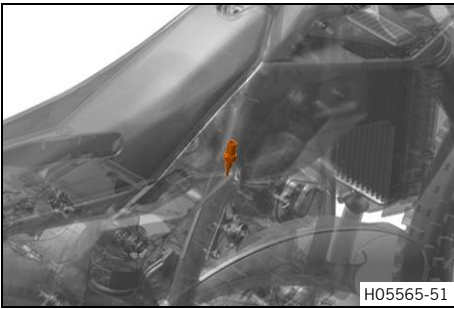

### Installation location

- The coolant temperature sensor is at the top of the cylinder head in the radiator hose.

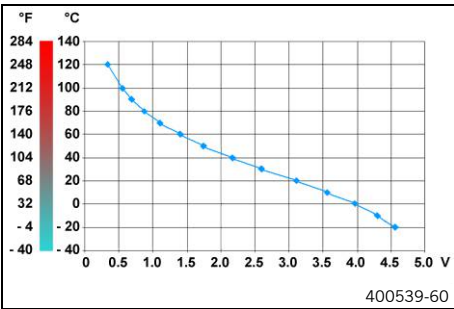

### Component description

- The coolant temperature sensor is an NTC resistor. In NTC resistors, the resistance decreases with increasing temperature; however, the "nil" value is never reached. When the temperature decreases, the resistance increases; however, the "infinite" value is never reached.

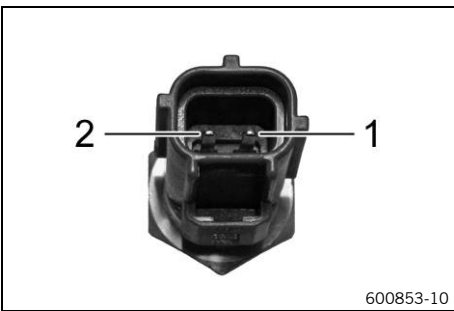

### Pin overview

- |   |               |
|---|---------------|
| 1 | Signal wire   |
| 2 | Sensor ground |

### Functional description

- The temperature sensor is used for the engine control.

Coolant temperature sensor	
Resistance at: -20 °C (-4 °F)	13.50 ... 16.50 kΩ
Voltage at: -20 °C (-4 °F)	4.5 V
Resistance at: -10 °C (14 °F)	8.24 ... 10.08 kΩ
Voltage at: -10 °C (14 °F)	4.3 V
Resistance at: 0 °C (32 °F)	5.17 ... 6.31 kΩ
Voltage at: 0 °C (32 °F)	3.9 V
Resistance at: 10 °C (50 °F)	3.33 ... 4.07 kΩ
Voltage at: 10 °C (50 °F)	3.5 V
Resistance at: 20 °C (68 °F)	2.21 ... 2.70 kΩ
Voltage at: 20 °C (68 °F)	3.1 V
Resistance at: 30 °C (86 °F)	1.49 ... 1.83 kΩ
Voltage at: 30 °C (86 °F)	2.5 V

## 2 ENGINE MANAGEMENT SYSTEM COMPONENTS

Resistance at: 40 °C (104 °F)	1.04 ... 1.27 kΩ
Voltage at: 40 °C (104 °F)	2.1 V
Resistance at: 50 °C (122 °F)	730 ... 892 Ω
Voltage at: 50 °C (122 °F)	1.7 V
Resistance at: 60 °C (140 °F)	526 ... 642 Ω
Voltage at: 60 °C (140 °F)	1.4 V
Resistance at: 70 °C (158 °F)	385 ... 471 Ω
Voltage at: 70 °C (158 °F)	1.0 V
Resistance at: 80 °C (176 °F)	286 ... 350 Ω
Voltage at: 80 °C (176 °F)	0.86 V
Resistance at: 90 °C (194 °F)	216 ... 264 Ω
Voltage at: 90 °C (194 °F)	0.68 V
Resistance at: 100 °C (212 °F)	165 ... 202 Ω
Voltage at: 100 °C (212 °F)	0.6 V
Resistance at: 110 °C (230 °F)	128 ... 156 Ω
Voltage at: 110 °C (230 °F)	0.44 V
Resistance at: 120 °C (248 °F)	100 ... 122 Ω
Voltage at: 120 °C (248 °F)	0.34 V

### 2.13 Crankshaft speed sensor

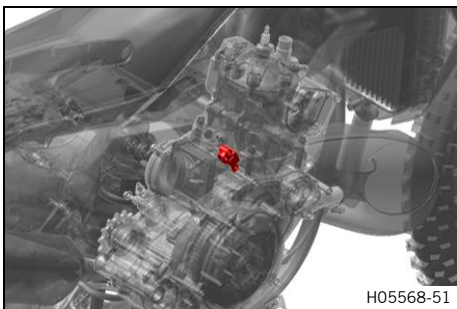

#### Installation location

- The crankshaft speed sensor is located on the left side of the engine below the alternator cover.

#### Component description

- The crankshaft speed sensor consists of a permanent magnet and an induction coil with a soft iron core. The counter piece to the crankshaft speed sensor is the trigger wheel whose teeth are equidistant except that one tooth is wider. The trigger wheel is attached to the alternator rotor. The rotor is connected to the crankshaft. There is a small air gap between the crankshaft speed sensor and the trigger wheel.

Crankshaft speed sensor connector **AT** (📖 p. 153) pin assignment

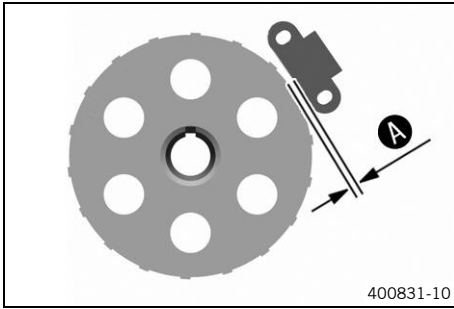

### Functional description

- The magnetic flux through the induction coil depends on whether a gap or a tooth is opposite to the crankshaft speed sensor. A tooth bundles the magnetic leakage flux of the permanent magnet while a gap weakens it. When the rotor and thus the trigger wheel turns, a magnetic field change is caused by each tooth. The change in the magnetic field generates an alternating voltage in the induction coil. The number of pulses per time unit are a measure of the rotating speed of the rotor. The wider tooth on the trigger wheel allows the engine control unit to detect the current position of the crankshaft.

Crankshaft speed sensor	
Resistance at: 20 °C (68 °F)	108 ... 132 Ω
Voltage at starting engine speed: 20 °C (68 °F)	≥ 2 V

## 2.14 Ignition coil

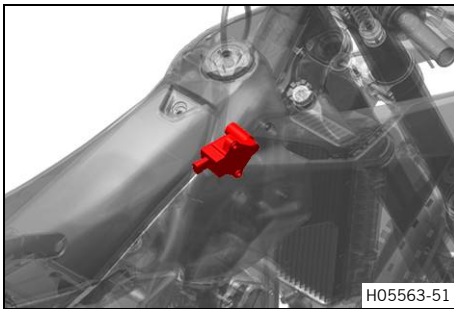

### Installation location

- The ignition coil is located above the cylinder head in the frame.

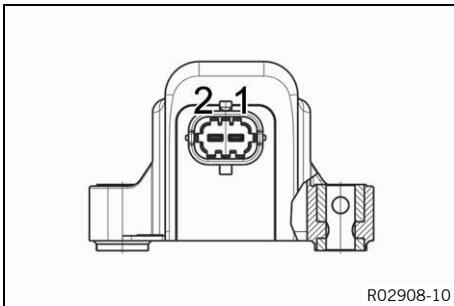

### Pin overview

- 1 (-) Ground
- 2 (+) Control wire

Ignition coil	
Primary winding resistance at: 20 °C (68 °F)	0.337 ... 0.412 Ω

## 2.15 Dwell

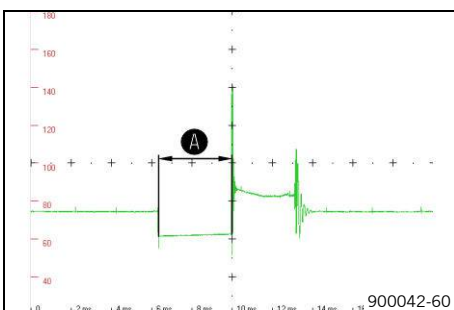

### Functional description

- The dwell angle **A** is the number of crankshaft degrees that the primary circuit is closed and the magnetic field builds up. The time is stated for which the primary circuit is closed.

## 2.16 Ignition point

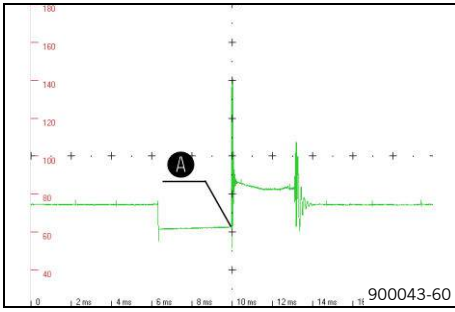

### Functional description

- The ignition point **A** is set relative to TDC and is expressed as a crankshaft angle. The spark is generated by interrupting the primary circuit.

## 2.17 Crankcase pressure sensor

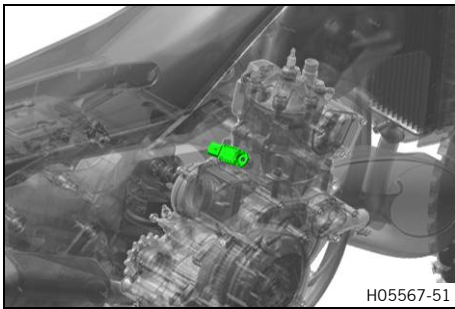

### Installation location

- The crankcase pressure sensor is located above the throttle valve body.

### Component description

- The electronics and a measuring cell are located in the housing of the induction manifold pressure sensor. In the measuring cell a diaphragm encloses a reference pressure chamber. When the shape of the diaphragm is altered by external pressure, the conductivity of the measuring resistors, and thus the measured voltage, is altered. The measured voltage is processed by the electronic system and forwarded to the engine control unit.

### Functional description

- The output voltage of the crankcase pressure sensor depends on the crankcase pressure and is output via the signal wire.

Crankcase pressure sensor voltage	
at: 133 mbar (1.93 psi)	1 V
at: 957 mbar (13.88 psi)	2.3 V
at: 2,500 mbar (36.26 psi)	4.75 V

## 2.18 Intake air temperature sensor

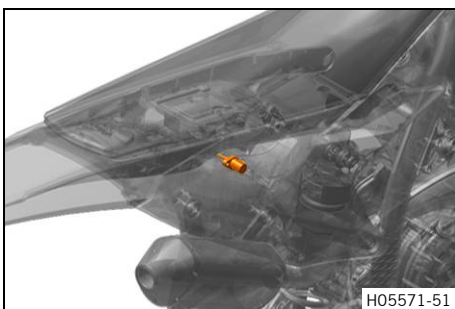

### Installation location

- The intake air temperature sensor is located on the air filter box.

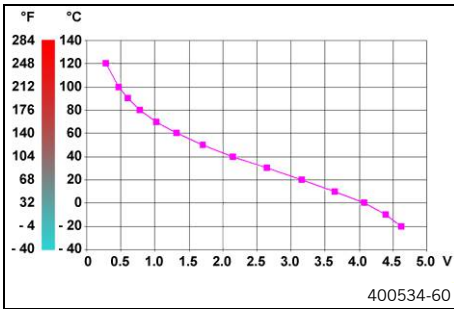

### Component description

- The intake air temperature sensor is an NTC resistor. In NTC resistors, the resistance decreases with increasing temperature; however, the "nil" value is never reached. When the temperature decreases, the resistance increases; however, the "infinite" value is never reached.

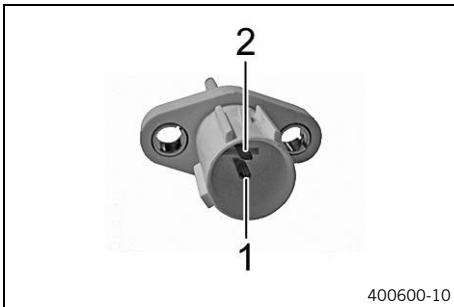

### Pin overview

- |   |               |
|---|---------------|
| 1 | Signal wire   |
| 2 | Sensor ground |

Intake air temperature sensor	
Resistance at: -20 °C (-4 °F)	18.80 kΩ
Voltage at: -20 °C (-4 °F)	4.67 V
Resistance at: 20 °C (68 °F)	2.942 kΩ
Voltage at: 20 °C (68 °F)	3.14 V
Resistance at: 40 °C (104 °F)	1.136 kΩ
Voltage at: 40 °C (104 °F)	2.15 V
Resistance at: 100 °C (212 °F)	0.1553 kΩ
Voltage at: 100 °C (212 °F)	0.46 V

## 2.19 Injection valves, cylinder 1



### Installation location

- Both injection valves are located on the throttle valve body. Injection valve 1 is located at the front of the throttle valve body in the direction of travel. Injection valve 2 is located at the rear of the throttle valve body in the direction of travel.

### Component description

- The injection valve consists of a solenoid, a spring-loaded plunger, a needle valve, and a filter. When current flows through the coil in the solenoid, a magnetic field is generated which attracts the plunger, overcoming the spring force; this lifts the needle valve off its seat. Fuel is discharged through eight injection holes and forms two conical jets. When the current is switched off, the magnetic field collapses and the spring closes the needle valve. The filter keeps any contamination out of the holes.

## 2 ENGINE MANAGEMENT SYSTEM COMPONENTS



### Pin overview

1	Control wire
2	Power supply

### Functional description

- The injection valve is supplied with power via terminal 15. The engine control unit calculates the injection rate required and grounds the injection valve via the amplification stage in the engine control unit. The longer the injection valve is connected to ground, the greater the fuel quantity injected.

Injection valve	
Resistance at: 20 °C (68 °F)	11.4 ... 12.6 Ω

### 2.20 Circuit A throttle valve position sensor

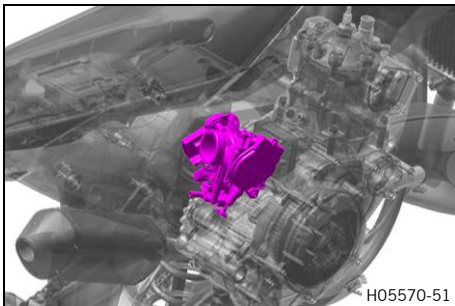

### Installation location

- Throttle valve position sensor circuit A is located on the left side of the throttle valve body.

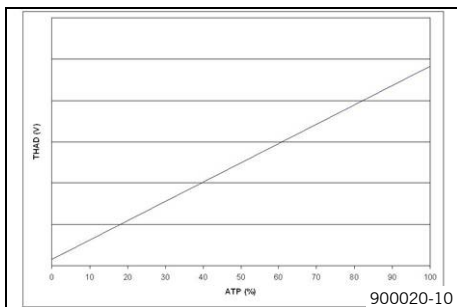

### Component description

- The throttle valve position sensor circuit A has a linear characteristic line and operates as a potentiometer.

Circuit A throttle valve position sensor connector **FT** (🔊 p. 154) pin assignment

### Functional description

- The output voltage of the throttle valve position sensor is dependent on the opening angle of the throttle valve and is sent via the signal wire to determine the throttle valve position.

Circuit A throttle valve position sensor	
Throttle valve position sensor voltage	0.52 ... 4.66 V
Circuit A throttle valve position sensor	
Throttle valve position	2.5 ... 84.5°

## 2.21 Ambient air pressure sensor

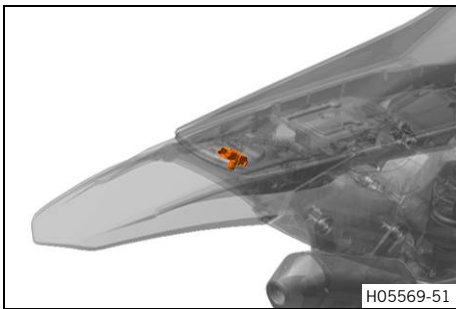

### Installation location

- The ambient air pressure sensor is located under the seat.

### Component description

- The electronics and a measuring cell are located in the housing of the ambient air pressure sensor. In the measuring cell a diaphragm encloses a reference pressure chamber. When the shape of the diaphragm is altered by external pressure, the conductivity of the measuring resistors, and thus the measured voltage, is altered. The measured voltage is processed by the electronic system and forwarded to the engine control unit.

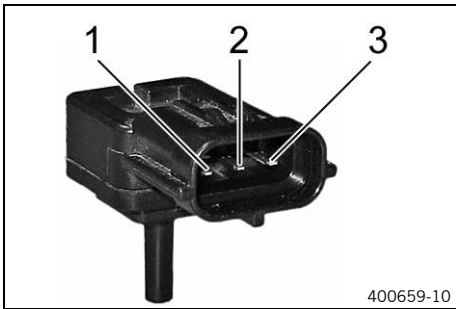

### Pin overview

1	Power supply
2	Sensor ground
3	Signal wire

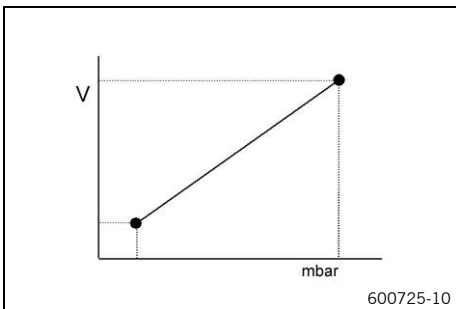

### Functional description

- The output voltage of the ambient air pressure sensor is adjusted depending on the ambient air pressure and is sent via the signal wire. The voltage signal rises when the ambient air pressure increases.

Ambient air pressure sensor voltage	
at: 133 mbar (1.93 psi)	1 V
at: 957 mbar (13.88 psi)	2.3 V
at: 2,500 mbar (36.26 psi)	4.75 V

## 2.22 Tilt sensor

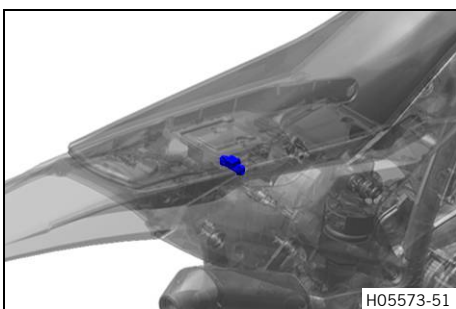

### Installation location

- The tilt sensor is located under the seat.

### Component description

- The sensor functions on the basis of the Hall effect. The tilt sensor contains a pendulum with a magnet. The pendulum passes over a Hall sensor. The electronics of the tilt sensor evaluate the Hall voltage and activate the signal voltage.

## 2 ENGINE MANAGEMENT SYSTEM COMPONENTS

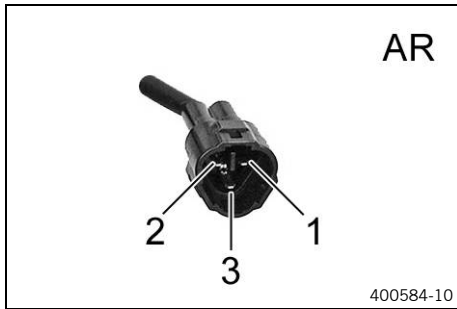

### Pin overview

1	Sensor ground
2	Power supply
3	Signal wire

### Functional description

- The tilt sensor is connected in series to measuring resistances on the voltage side and ground side, both of which are in the engine control unit. Depending on the vehicle inclination, the electronic system of the tilt sensor switches the signal voltage either toward the voltage or toward the ground using a resistor. The engine control unit detects the inclination of the vehicle on the basis of the voltage value of the signal wire.

Tilt sensor	
Voltage (rollover AD) "no fall detected"	0.4 ... 1.4 V
Voltage (RolloverAD) "fall detected"	3.7 ... 4.1 V

### 2.23 Engine control unit

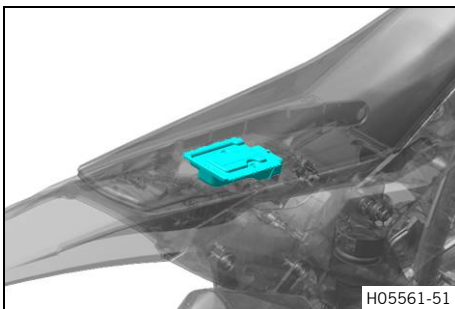

### Installation location

- The engine control unit is located under the seat.

### i Info

When an engine control unit from the parts center is initially programmed, it is given an identity. This means that if the engine control unit is specified, e.g. with the flash file KMA440EUxxxxxx/KMA450EUxxxxxx (250/300 SX/XC series), the engine control unit is defined as a version A440/A450, and can from then on only be used on model series A440/A450 (specifically installed control unit).

After completing programming, the vehicle identification number must be entered into the engine control unit using the "Coding" function.

As soon as the diagnostics tool is connected, the service hour counter starts running.

Before longer diagnostic sessions, unplug the service hour counter behind the start number plate.

Engine control unit connector **RP** (🔌 p. 157) pin assignment

### 2.24 Diagnostics connector

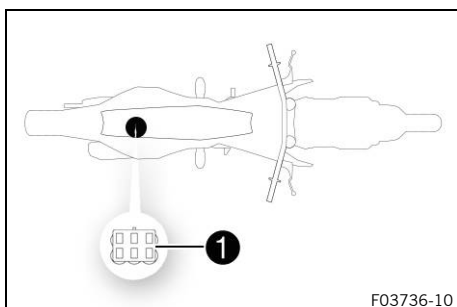

Diagnostics connector **1** is located under the seat.

### i Info

As soon as the diagnostics tool is connected, the service hour counter starts running.

Before longer diagnostic sessions, unplug the service hour counter behind the start number plate.

## 2.25 Exhaust control actuator

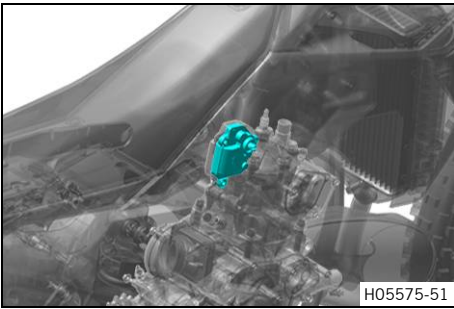

### Installation location

- The exhaust control actuator is located on the left side of the cylinder head.

### Component description

- The exhaust control actuator optimizes performance. Settings are made via an actuator. Depending on engine speed, the control flap is altered via the exhaust control actuator. The engine control unit controls the exhaust control actuator.

Exhaust control actuator connector **ON** (📖 p. 157) pin assignment

## 2.26 Connectivity Unit

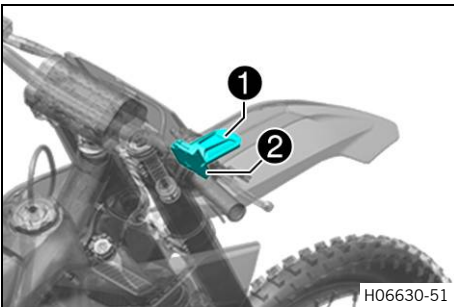

### Installation location

- The Connectivity Unit is located behind the start number plate.

### Setup

- The Connectivity consists of the **1** aerial and the **2** control unit.

### Component description

- The Connectivity Unit is equipped with a Bluetooth module, which allows it to be paired with a smartphone, and it offers a wide range of functions and setting options.

Connectivity Unit connector **OJ** (📖 p. 156) pin assignment

### 3 ENGINE CONTROL TROUBLE CODE

<b>Blink code for malfunction indicator lamp</b>	 14 Malfunction indicator lamp flashes 1x long, 4x short
<b>Display on diagnostic tool</b>	P010100 "Crankcase pressure sensor" "Difference too high"
<b>Error level condition</b>	Crankcase pressure sensor – difference too high between sensor and engine control unit
<b>Function check</b>	Checking the crankcase pressure sensor (📖 p. 18)
<b>Last measure if none of the documented causes leads to elimination of the fault</b>	– Contact customer service.

#### Checking the crankcase pressure sensor

- Check the hose of the crankcase pressure sensor for damage and dirt.
- Clear the fault memory using the KTM diagnostics tool.
  - » Take a test ride.
    - Read out the fault memory using the KTM diagnostics tool.

#### **Last measure if none of the documented causes leads to elimination of the fault**

- Contact customer service.

<b>Blink code for malfunction indicator lamp</b>	<b>Fi</b> 09 Malfunction indicator lamp flashes 9x short
<b>Display on diagnostic tool</b>	P010711 "Crankcase pressure sensor" "Short circuit to ground"
<b>Error level condition</b>	Crankcase pressure sensor - short circuit to ground Voltage: $\leq 0.4$ V Time: $\geq 0.1$ s
<b>Possible cause</b>	Crankcase pressure sensor – the power supply is faulty (📖 p. 19) Crankcase pressure sensor - the signal wire has a short circuit to ground (terminal 31) (📖 p. 20) Crankcase pressure sensor – the signal wire has a short circuit to sensor ground (📖 p. 20)
<b>Last measure if none of the documented causes leads to elimination of the fault</b>	– Contact customer service.

### Crankcase pressure sensor – the power supply is faulty

#### Condition

The diagnostics tool is connected and running.

Engine control unit is connected. (📖 p. 16)

Crankcase pressure sensor is disconnected. (📖 p. 12)

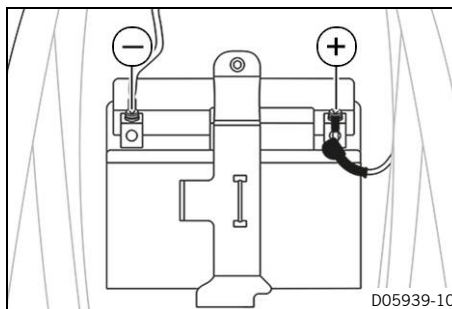
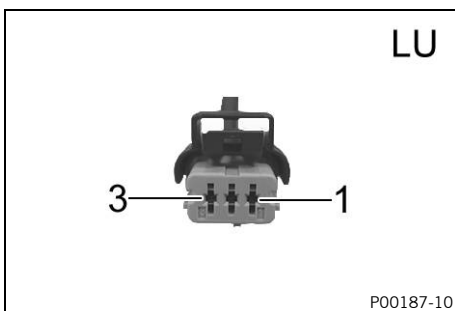

#### Crankcase pressure sensor – check the power supply.

- **V** Measure the voltage between the specified points.  
Crankcase pressure sensor connector **LU** pin **1** – Measuring point **Ground (-)**



#### Info

For the measurement, the measuring points must be subjected to a 12 V/21 W bulb.

Voltage	4.9 ... 5.1 V
---------	---------------

- » If the specifications have not been met:
  - Check connector **LU** (📖 p. 156) pin **1**.
  - Check the cable from connector **LU** (📖 p. 156) pin **1** to the next node in the wiring harness.
- » If the specifications have been met:
  - Check the next possible cause:  
Crankcase pressure sensor - the signal wire has a short circuit to ground (terminal 31) (📖 p. 20)

## Crankcase pressure sensor - the signal wire has a short circuit to ground (terminal 31)

### Condition

The diagnostics tool is disconnected.

Engine control unit is disconnected. (📖 p. 16)

Crankcase pressure sensor is disconnected. (📖 p. 12)

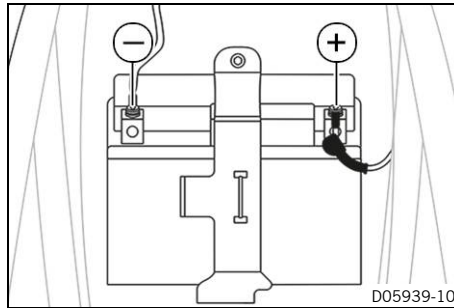
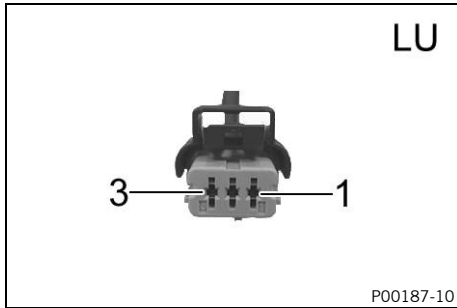

### Crankcase pressure sensor – check the signal wire for a short circuit to ground (terminal 31).

-  Measure the resistance between the specified points.  
Crankcase pressure sensor connector **LU** pin **3** – Measuring point **Ground (-)**

Resistance	$\infty \Omega$
------------	-----------------

- » If the specifications have not been met:
  - Check the cable of connector **LU** (📖 p. 156) pin **3** to engine control unit connector **RP** (📖 p. 157) pin **E1** for a short circuit to ground (terminal 31).
- » If the specifications have been met:
  - Check the next possible cause:  
Crankcase pressure sensor – the signal wire has a short circuit to sensor ground (📖 p. 20)

## Crankcase pressure sensor – the signal wire has a short circuit to sensor ground

### Condition

The diagnostics tool is disconnected.

Engine control unit is disconnected. (📖 p. 16)

Crankcase pressure sensor is disconnected. (📖 p. 12)

### Crankcase pressure sensor – check the signal wire for a short circuit to sensor ground.

-  Measure the resistance between the specified points.  
Crankcase pressure sensor connector **LU** pin **3** –  
Crankcase pressure sensor connector **LU** pin **2**

Resistance	$\infty \Omega$
------------	-----------------

- » If the specifications have not been met:
  - Check the cable from connector **LU** (📖 p. 156) pin **3** to engine control unit connector **RP** (📖 p. 157) pin **E1** for a short circuit to sensor ground.
- » If the specifications have been met:
  - Contact customer service.

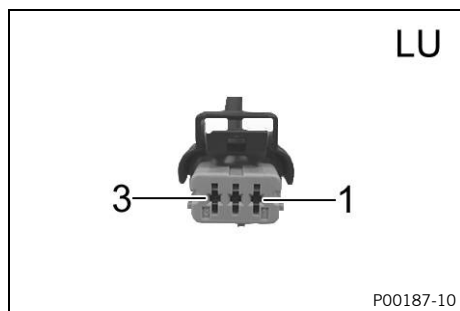

<b>Blink code for malfunction indicator lamp</b>	<b>Fi</b> 09 Malfunction indicator lamp flashes 9x short
<b>Display on diagnostic tool</b>	P010812 "Crankcase pressure sensor" "Open/short circuit to plus"
<b>Error level condition</b>	Crankcase pressure sensor - open/short circuit to plus Voltage: $\geq 4.6$ V Time: $\geq 0.1$ s
<b>Possible cause</b>	Crankcase pressure sensor – the signal wire is faulty (🔧 p. 21)
	Crankcase pressure sensor - the ground wire is faulty (🔧 p. 22)
	Crankcase pressure sensor – the signal wire has a short circuit to plus (terminal 30) (🔧 p. 22)
	Crankcase pressure sensor – the signal wire has a short circuit to ignition plus (terminal 15) (🔧 p. 23)
	Crankcase pressure sensor – the signal wire has a short circuit to the sensor power supply (🔧 p. 23)
<b>Last measure if none of the documented causes leads to elimination of the fault</b>	– Contact customer service.

## Crankcase pressure sensor – the signal wire is faulty

### Condition

The diagnostics tool is disconnected.

Engine control unit is disconnected. (🔧 p. 16)

The break out box is connected to the engine control unit wiring harness with adapter **00029095016**.

Crankcase pressure sensor is disconnected. (🔧 p. 12)

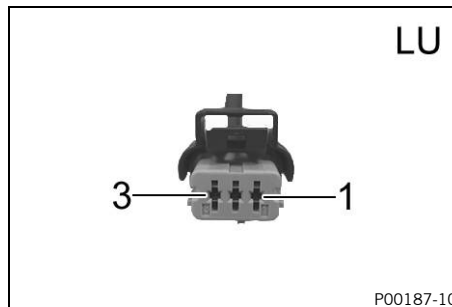
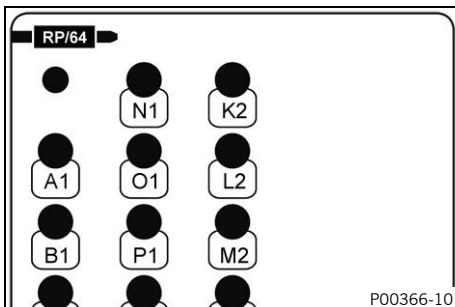

### Crankcase pressure sensor – check the signal wire.

- Measure the resistance between the specified points.  
Bob box connector **RP** pin **E1** – Crankcase pressure sensor connector **LU** pin **3**

Resistance	$\leq 0.6 \Omega$
------------	-------------------

- » If the specifications have not been met:
  - Check engine control unit connector **RP** (🔧 p. 157) pin **E1** and connector **LU** (🔧 p. 156) pin **3**.
  - Check the cable from engine control unit connector **RP** (🔧 p. 157) pin **E1** to connector **LU** (🔧 p. 156) pin **3**.
- » If the specifications have been met:
  - Check the next possible cause:  
Crankcase pressure sensor - the ground wire is faulty (🔧 p. 22)

### 3 ENGINE CONTROL TROUBLE CODE

#### Crankcase pressure sensor - the ground wire is faulty

##### Condition

The diagnostics tool is disconnected.

Engine control unit is disconnected. (📖 p. 16)

The break out box is connected to the engine control unit wiring harness with adapter **00029095016**.

Crankcase pressure sensor is disconnected. (📖 p. 12)

The tilt sensor is disconnected. (📖 p. 15)

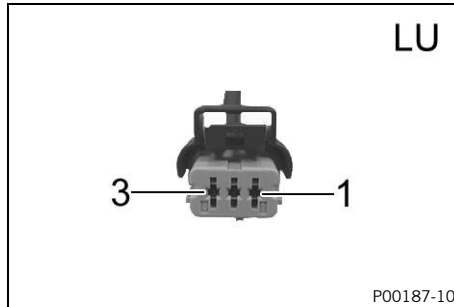
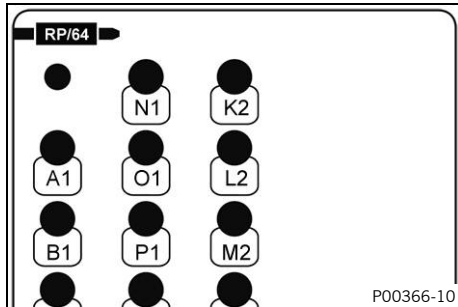

#### Crankcase pressure sensor - check the ground wire.

- Measure the resistance between the specified points.  
Bob box connector **RP** pin **C2** – Crankcase pressure sensor connector **LU** pin **2**

Resistance	≤ 0.6 Ω
------------	---------

- » If the specifications have not been met:
  - Check engine control unit connector **RP** (📖 p. 157) pin **C2** and connector **LU** (📖 p. 156) pin **2**.
  - Check the cable from engine control unit connector **RP** (📖 p. 157) pin **C2** to connector **LU** (📖 p. 156) pin **2**.
- » If the specifications have been met:
  - Check the next possible cause:  
Crankcase pressure sensor – the signal wire has a short circuit to plus (terminal 30) (📖 p. 22)

#### Crankcase pressure sensor – the signal wire has a short circuit to plus (terminal 30)

##### Condition

The diagnostics tool is disconnected.

Engine control unit is disconnected. (📖 p. 16)

The break out box is connected to the engine control unit wiring harness with adapter **00029095016**.

Crankcase pressure sensor is disconnected. (📖 p. 12)

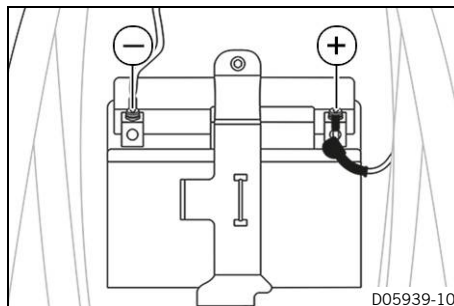
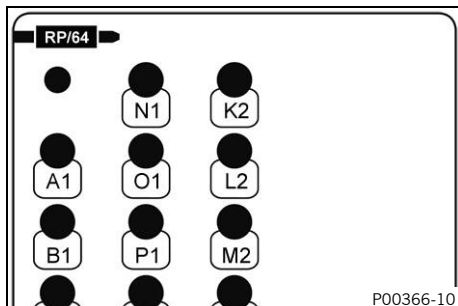

#### Crankcase pressure sensor – check the signal wire for a short circuit to plus (terminal 30).

- Measure the voltage between the specified points.  
Bob box connector **RP** pin **E1** – Measuring point **Ground (-)**

Voltage	< 0.1 V
---------	---------

- » If the specifications have not been met:

- Check the cable from engine control unit connector **RP** (📖 p. 157) pin **E1** to connector **LU** (📖 p. 156) pin **3** for a short circuit to plus (terminal 30).
- » If the specifications have been met:
  - Check the next possible cause:
    - Crankcase pressure sensor – the signal wire has a short circuit to ignition plus (terminal 15) (📖 p. 23)

## Crankcase pressure sensor – the signal wire has a short circuit to ignition plus (terminal 15)

### Condition

The diagnostics tool is disconnected.

Engine control unit is disconnected. (📖 p. 16)

The break out box is connected to the engine control unit wiring harness with adapter **00029095016**.

Crankcase pressure sensor is disconnected. (📖 p. 12)

### Crankcase pressure sensor – check the signal wire for a short circuit to ignition plus (terminal 15).

-  Measure the resistance between the specified points.  
Bob box connector **RP** pin **E1** – Bob box connector **RP** pin **D4**

Resistance	$\infty \Omega$
------------	-----------------

- » If the specifications have not been met:
  - Check the cable from engine control unit connector **E1** (📖 p. 157) pin **E1** to connector **LU** (📖 p. 156) pin **3** for a short circuit to ignition plus (terminal 15).
- » If the specifications have been met:
  - Check the next possible cause:
    - Crankcase pressure sensor – the signal wire has a short circuit to the sensor power supply (📖 p. 23)

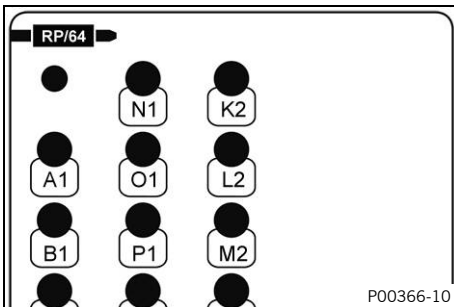

## Crankcase pressure sensor – the signal wire has a short circuit to the sensor power supply

### Condition

The diagnostics tool is disconnected.

Engine control unit is disconnected. (📖 p. 16)

The break out box is connected to the engine control unit wiring harness with adapter **00029095016**.

Crankcase pressure sensor is disconnected. (📖 p. 12)

### Crankcase pressure sensor – check the signal wire for a short circuit to the sensor power supply.

-  Measure the resistance between the specified points.  
Bob box connector **RP** pin **E1** – Bob box connector **RP** pin **D3**

Resistance	$\infty \Omega$
------------	-----------------

- » If the specifications have not been met:
  - Check the cable from engine control unit connector **RP** (📖 p. 157) pin **E1** to connector **LU** (📖 p. 156) pin **3** for a short circuit to the sensor power supply.
- » If the specifications have been met:
  - Contact customer service.

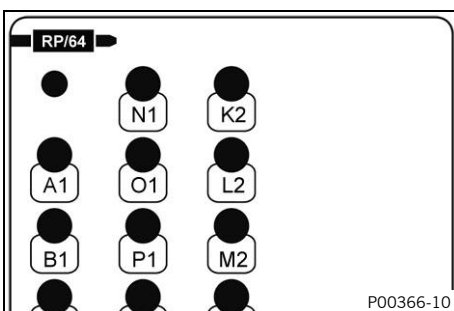

### 3 ENGINE CONTROL TROUBLE CODE

<b>Blink code for malfunction indicator lamp</b>	 13 Malfunction indicator lamp flashes 1x long, 3x short
<b>Display on diagnostic tool</b>	P011211 <b>"Intake air temperature sensor"</b> <b>"Input signal too low"</b>
<b>Error level condition</b>	Intake air temperature sensor – input signal too low Voltage: $\leq 0.2$ V Time: $\geq 3$ s
<b>Function check</b>	Intake air temperature sensor - checking the temperature (📖 p. 24)
<b>Possible cause</b>	Intake air temperature sensor – the value is not plausible (📖 p. 24)
	Intake air temperature sensor – the signal wire has a short circuit to ground (terminal 31) (📖 p. 25)
	Intake air temperature sensor – the signal wire has a short circuit to sensor ground (📖 p. 26)
<b>Last measure if none of the documented causes leads to elimination of the fault</b>	– Contact customer service.

#### Intake air temperature sensor - checking the temperature

##### Condition

The diagnostics tool is connected and running.

- Select **"Engine control unit" > "Measured values" > "Intake air temperature"**.

##### Guideline

The intake air temperature is plausible.

- » If the displayed value is equal to the setpoint value:
  - Clear the fault memory using the KTM diagnostics tool.
  - Take a test ride.
  - Read out the fault memory using the KTM diagnostics tool.
- » If the displayed value is below the setpoint value:
  - Check the next possible cause:  
Intake air temperature sensor – the value is not plausible (📖 p. 24)
  - Check the next possible cause:  
Intake air temperature sensor – the signal wire has a short circuit to ground (terminal 31) (📖 p. 25)
  - Check the next possible cause:  
Intake air temperature sensor – the signal wire has a short circuit to sensor ground (📖 p. 26)

#### Intake air temperature sensor – the value is not plausible

##### Condition

The diagnostics tool is disconnected.

The intake air temperature sensor is removed. (📖 p. 12)

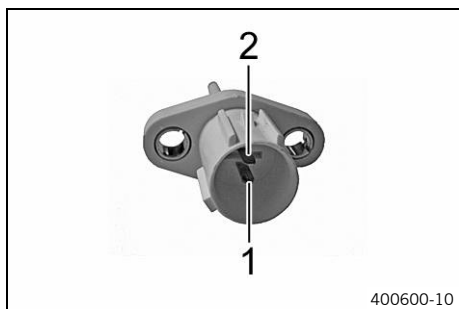

### Intake air temperature sensor – check the resistance.

- Measure the resistance between the specified points.  
Intake air temperature sensor pin 1 – Intake air temperature sensor pin 2

Intake air temperature sensor	
Resistance at: -20 °C (-4 °F)	18.80 kΩ
Voltage at: -20 °C (-4 °F)	4.67 V
Resistance at: 20 °C (68 °F)	2.942 kΩ
Voltage at: 20 °C (68 °F)	3.14 V
Resistance at: 40 °C (104 °F)	1.136 kΩ
Voltage at: 40 °C (104 °F)	2.15 V
Resistance at: 100 °C (212 °F)	0.1553 kΩ
Voltage at: 100 °C (212 °F)	0.46 V

- » If the specifications have not been met:
  - Change the intake air temperature sensor.
- » If the specifications have been met:
  - Check the next possible cause:  
Intake air temperature sensor – the signal wire has a short circuit to ground (terminal 31) (📖 p. 25)

### Intake air temperature sensor – the signal wire has a short circuit to ground (terminal 31)

#### Condition

The diagnostics tool is disconnected.

Engine control unit is disconnected. (📖 p. 16)

The break out box is connected to the engine control unit wiring harness with adapter **00029095016**.

The intake air temperature sensor is disconnected. (📖 p. 12)

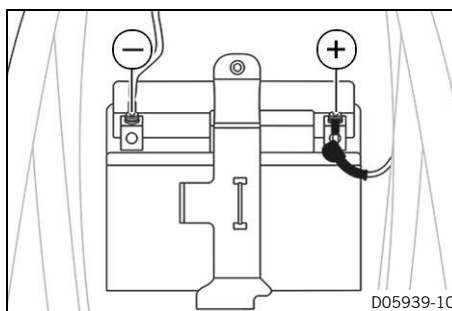
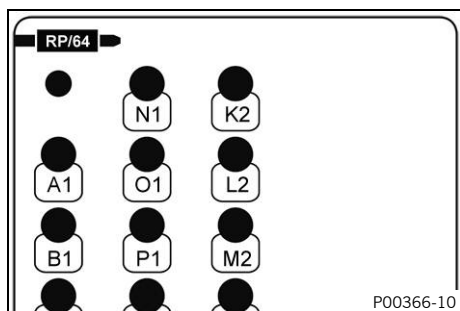

### Intake air temperature sensor – check the signal wire for a short circuit to ground (terminal 31).

- Measure the resistance between the specified points.  
Bob box connector **RP** pin **K1** – Measuring point **Ground (-)**

Resistance	$\infty \Omega$
------------	-----------------

- » If the specifications have not been met:
  - Check the cable from engine control unit connector **RP** (📖 p. 157) pin **K1** to connector **CM** (📖 p. 153) pin **1** for a short circuit to ground (terminal 31).
- » If the specifications have been met:

### 3 ENGINE CONTROL TROUBLE CODE

- Check the next possible cause:  
Intake air temperature sensor – the signal wire has a short circuit to sensor ground (📖 p. 26)

#### Intake air temperature sensor – the signal wire has a short circuit to sensor ground

##### Condition

The diagnostics tool is disconnected.

Engine control unit is disconnected. (📖 p. 16)

The break out box is connected to the engine control unit wiring harness with adapter **00029095016**.

The intake air temperature sensor is disconnected. (📖 p. 12)

##### Intake air temperature sensor – check the signal wire for a short circuit to sensor ground.

-  Measure the resistance between the specified points.  
Bob box connector **RP** pin **K1** – Bob box connector **RP** pin **J2**

Resistance	$\infty \Omega$
------------	-----------------

- » If the specifications have not been met:
  - Check cable from engine control unit connector **RP** (📖 p. 157) pin **K1** to connector **CM** (📖 p. 153) pin **1** for a short circuit to sensor ground.
- » If the specifications have been met:
  - Contact customer service.

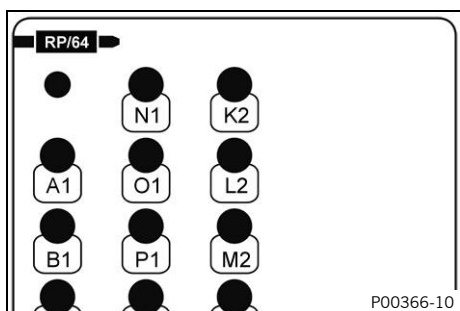

<b>Blink code for malfunction indicator lamp</b>	<div style="border: 1px solid black; padding: 2px; display: inline-block; font-weight: bold; font-size: 1.2em;">Fi</div> 13 Malfunction indicator lamp flashes 1x long, 3x short
<b>Display on diagnostic tool</b>	P011312 <b>"Intake air temperature sensor"</b> <b>"Input signal too high"</b>
<b>Error level condition</b>	Intake air temperature sensor – input signal too high Voltage: $\geq 4.8$ V Time: $\geq 3$ s
<b>Function check</b>	Intake air temperature sensor - checking the temperature (🔧 p. 27)
<b>Possible cause</b>	Intake air temperature sensor – the value is not plausible (🔧 p. 28)
	Intake air temperature sensor – the signal wire is faulty (🔧 p. 28)
	Intake air temperature sensor – the ground wire is faulty (🔧 p. 29)
	Intake air temperature sensor – the signal wire has a short circuit to plus (terminal 30) (🔧 p. 29)
	Intake air temperature sensor – the signal wire has a short circuit to ignition plus (terminal 15) (🔧 p. 30)
	Intake air temperature sensor – the signal wire has a short circuit to the sensor power supply (🔧 p. 30)
<b>Last measure if none of the documented causes leads to elimination of the fault</b>	– Contact customer service.

## Intake air temperature sensor - checking the temperature

### Condition

The diagnostics tool is connected and running.

- Select **"Engine control unit" > "Measured values" > "Intake air temperature"**.

### Guideline

The intake air temperature is plausible.

- » If the displayed value is equal to the setpoint value:
  - Clear the fault memory using the KTM diagnostics tool.
  - Take a test ride.
  - Read out the fault memory using the KTM diagnostics tool.
- » If the displayed value is above the setpoint value:
  - Check the next possible cause:  
Intake air temperature sensor – the value is not plausible (🔧 p. 28)
  - Check the next possible cause:  
Intake air temperature sensor – the signal wire is faulty (🔧 p. 28)
  - Check the next possible cause:  
Intake air temperature sensor – the ground wire is faulty (🔧 p. 29)
  - Check the next possible cause:  
Intake air temperature sensor – the signal wire has a short circuit to plus (terminal 30) (🔧 p. 29)
  - Check the next possible cause:  
Intake air temperature sensor – the signal wire has a short circuit to ignition plus (terminal 15) (🔧 p. 30)
  - Check the next possible cause:  
Intake air temperature sensor – the signal wire has a short circuit to the sensor power supply (🔧 p. 30)

## Intake air temperature sensor – the value is not plausible

### Condition

The diagnostics tool is disconnected.

The intake air temperature sensor is removed. (📖 p. 12)

### Intake air temperature sensor – check the resistance.

-  Measure the resistance between the specified points.  
Intake air temperature sensor pin 1 – Intake air temperature sensor pin 2

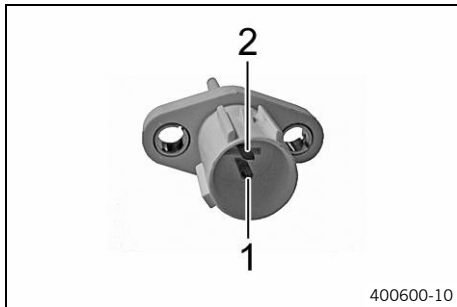

Intake air temperature sensor	
Resistance at: -20 °C (-4 °F)	18.80 kΩ
Voltage at: -20 °C (-4 °F)	4.67 V
Resistance at: 20 °C (68 °F)	2.942 kΩ
Voltage at: 20 °C (68 °F)	3.14 V
Resistance at: 40 °C (104 °F)	1.136 kΩ
Voltage at: 40 °C (104 °F)	2.15 V
Resistance at: 100 °C (212 °F)	0.1553 kΩ
Voltage at: 100 °C (212 °F)	0.46 V

- › If the specifications have not been met:
  - Change the intake air temperature sensor.
- › If the specifications have been met:
  - Check the next possible cause:  
Intake air temperature sensor – the signal wire is faulty (📖 p. 28)

## Intake air temperature sensor – the signal wire is faulty

### Condition

The diagnostics tool is disconnected.

Engine control unit is disconnected. (📖 p. 16)

The break out box is connected to the engine control unit wiring harness with adapter **00029095016**.

The intake air temperature sensor is disconnected. (📖 p. 12)

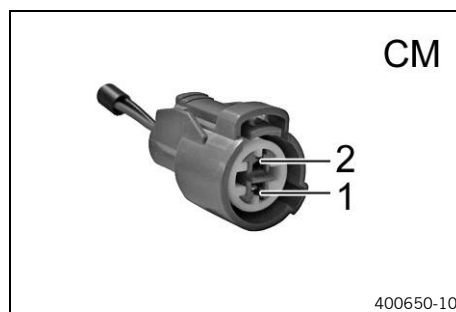
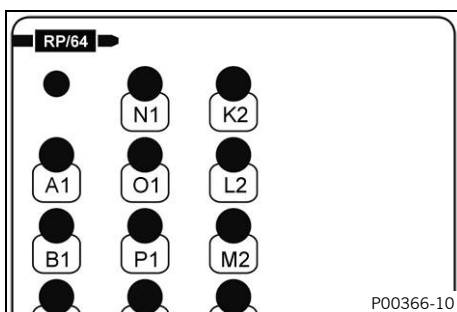

### Intake air temperature sensor – check the signal wire.

-  Measure the resistance between the specified points.  
Bob box connector **RP** pin **K1** – Intake air temperature sensor connector **CM** pin 1

Resistance	$\leq 0.6 \Omega$
------------	-------------------

- » If the specifications have not been met:
  - Check engine control unit connector **RP** (📖 p. 157) pin **K1** and connector **CM** (📖 p. 153) pin **1**.
  - Check the cable from engine control unit connector **RP** (📖 p. 157) pin **K1** to connector **CM** (📖 p. 153) pin **1**.
- » If the specifications have been met:
  - Check the next possible cause:  
Intake air temperature sensor – the ground wire is faulty (📖 p. 29)

### Intake air temperature sensor – the ground wire is faulty

**Condition**

The diagnostics tool is disconnected.

Engine control unit is disconnected. (📖 p. 16)

The break out box is connected to the engine control unit wiring harness with adapter **00029095016**.

The intake air temperature sensor is disconnected. (📖 p. 12)

The coolant temperature sensor is disconnected. (📖 p. 9)

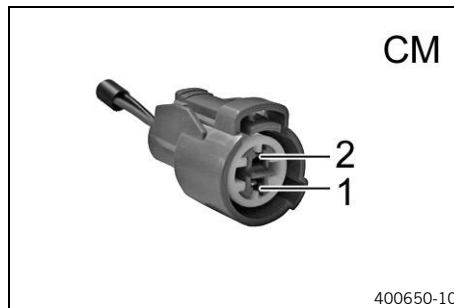
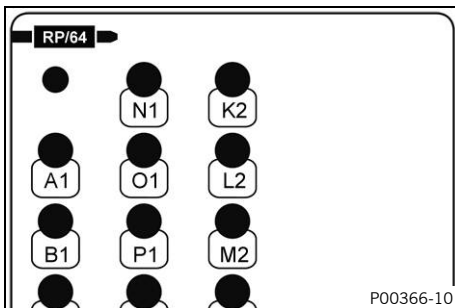

**Intake air temperature sensor – check the ground wire.**

- Measure the resistance between the specified points.  
Bob box connector **RP** pin **J2** – Intake air temperature sensor connector **CM** pin **2**

Resistance	$\leq 0.6 \Omega$
------------	-------------------

- » If the specifications have not been met:
  - Check engine control unit connector **RP** (📖 p. 157) pin **J2** and connector **CM** (📖 p. 153) pin **2**.
  - Check the cable from engine control unit connector **RP** (📖 p. 157) pin **J2** to connector **CM** (📖 p. 153) pin **2**.
- » If the specifications have been met:
  - Check the next possible cause:  
Intake air temperature sensor – the signal wire has a short circuit to plus (terminal 30) (📖 p. 29)

### Intake air temperature sensor – the signal wire has a short circuit to plus (terminal 30)

**Condition**

The diagnostics tool is disconnected.

Engine control unit is disconnected. (📖 p. 16)

The break out box is connected to the engine control unit wiring harness with adapter **00029095016**.

The intake air temperature sensor is disconnected. (📖 p. 12)

### 3 ENGINE CONTROL TROUBLE CODE

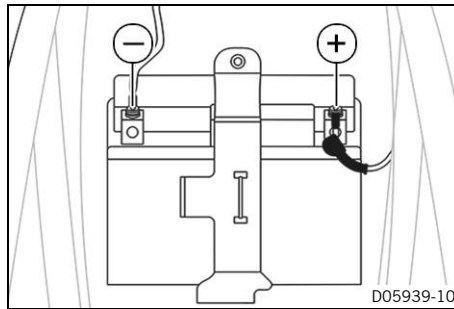
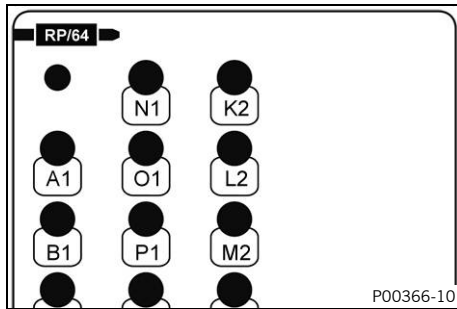

#### Intake air temperature sensor – check the signal wire for a short circuit to plus (terminal 30).

- **V** Measure the voltage between the specified points.  
Bob box connector **RP** pin **K1** – Measuring point **Ground** (-)

Voltage	≤ 0.1 V
---------	---------

- » If the specifications have not been met:
  - Check the cable from engine control unit connector **RP** (p. 157) pin **K1** to connector **CM** (p. 153) pin **1** for a short circuit to plus (terminal 30).
- » If the specifications have been met:
  - Check the next possible cause:  
Intake air temperature sensor – the signal wire has a short circuit to ignition plus (terminal 15) (p. 30)

#### Intake air temperature sensor – the signal wire has a short circuit to ignition plus (terminal 15)

##### Condition

The diagnostics tool is disconnected.  
 Engine control unit is disconnected. (p. 16)  
 The break out box is connected to the engine control unit wiring harness with adapter **00029095016**.  
 The intake air temperature sensor is disconnected. (p. 12)

#### Intake air temperature sensor – check the signal wire for a short circuit to ignition plus (terminal 15).

- **Ω** Measure the resistance between the specified points.  
Bob box connector **RP** pin **K1** – Bob box connector **RP** pin **D4**

Resistance	∞ Ω
------------	-----

- » If the specifications have not been met:
  - Check the cable from engine control unit connector **RP** (p. 157) pin **K1** to connector **CM** (p. 153) pin **1** for a short circuit to ignition plus (terminal 15).
- » If the specifications have been met:
  - Check the next possible cause:  
Intake air temperature sensor – the signal wire has a short circuit to the sensor power supply (p. 30)

#### Intake air temperature sensor – the signal wire has a short circuit to the sensor power supply

##### Condition

The diagnostics tool is disconnected.  
 Engine control unit is disconnected. (p. 16)  
 The break out box is connected to the engine control unit wiring harness with adapter **00029095016**.  
 The intake air temperature sensor is disconnected. (p. 12)

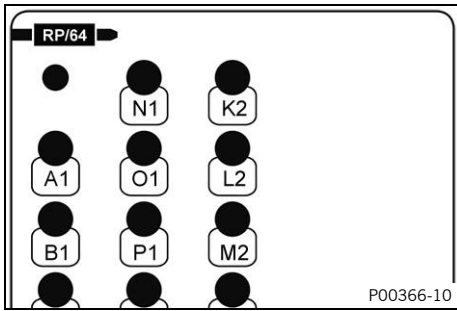

**Intake air temperature sensor – check the signal wire for a short circuit to the sensor power supply.**

-  Measure the resistance between the specified points.  
Bob box connector **RP** pin **K1** – Bob box connector **RP** pin **D3**

Resistance	$\infty \Omega$
------------	-----------------

- » If the specifications have not been met:
  - Check the cable from engine control unit connector **RP** (📖 p. 157) pin **K1** to connector **CM** (📖 p. 153) pin **T** for a short circuit to the sensor power supply.
- » If the specifications have been met:
  - Contact customer service.

### 3 ENGINE CONTROL TROUBLE CODE

<b>Blink code for malfunction indicator lamp</b>	 12 Malfunction indicator lamp flashes 1x long, 2x short
<b>Display on diagnostic tool</b>	P011711 <b>"Coolant temperature sensor"</b> <b>"Input signal too low"</b>
<b>Error level condition</b>	Coolant temperature sensor – input signal too low Voltage: $\leq 0.1$ V Time: $\geq 3$ s
<b>Function check</b>	Coolant temperature sensor – checking the temperature (📖 p. 32)
<b>Possible cause</b>	Coolant temperature sensor – the value is not plausible (📖 p. 32)
	Coolant temperature sensor – the signal wire has a short circuit to ground (terminal 31) (📖 p. 34)
	Coolant temperature sensor – the signal wire has a short circuit to sensor ground (📖 p. 35)
<b>Last measure if none of the documented causes leads to elimination of the fault</b>	– Contact customer service.

#### Coolant temperature sensor – checking the temperature

##### Condition

The diagnostics tool is connected and running.

- Select **"Engine control unit" > "Measured values" > "Coolant temperature"**.

##### Guideline

Engine temperature is plausible.

- » If the displayed value is equal to the setpoint value:
  - Clear the fault memory using the KTM diagnostics tool.
  - Take a test ride.
  - Read out the fault memory using the KTM diagnostics tool.
- » If the displayed value is below the setpoint value:
  - Check the next possible cause:  
Coolant temperature sensor – the value is not plausible (📖 p. 32)
  - Check the next possible cause:  
Coolant temperature sensor – the signal wire has a short circuit to ground (terminal 31) (📖 p. 34)
  - Check the next possible cause:  
Coolant temperature sensor – the signal wire has a short circuit to sensor ground (📖 p. 35)

#### Coolant temperature sensor – the value is not plausible

##### Condition

The diagnostics tool is disconnected.

The coolant temperature sensor is disconnected. (📖 p. 9)

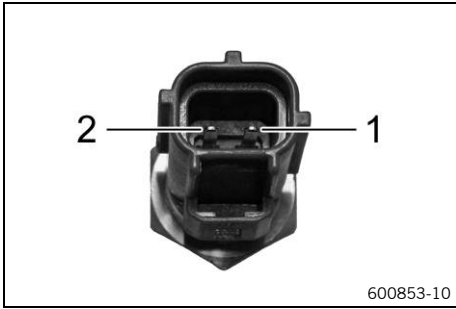

### Coolant temperature sensor – check the resistance.

- $\Omega$  Measure the resistance between the specified points.  
Coolant temperature sensor pin 1 – Coolant temperature sensor pin 2

Coolant temperature sensor	
Resistance at: -20 °C (-4 °F)	13.50 ... 16.50 k $\Omega$
Voltage at: -20 °C (-4 °F)	4.5 V
Resistance at: -10 °C (14 °F)	8.24 ... 10.08 k $\Omega$
Voltage at: -10 °C (14 °F)	4.3 V
Resistance at: 0 °C (32 °F)	5.17 ... 6.31 k $\Omega$
Voltage at: 0 °C (32 °F)	3.9 V
Resistance at: 10 °C (50 °F)	3.33 ... 4.07 k $\Omega$
Voltage at: 10 °C (50 °F)	3.5 V
Resistance at: 20 °C (68 °F)	2.21 ... 2.70 k $\Omega$
Voltage at: 20 °C (68 °F)	3.1 V
Resistance at: 30 °C (86 °F)	1.49 ... 1.83 k $\Omega$
Voltage at: 30 °C (86 °F)	2.5 V
Resistance at: 40 °C (104 °F)	1.04 ... 1.27 k $\Omega$
Voltage at: 40 °C (104 °F)	2.1 V
Resistance at: 50 °C (122 °F)	730 ... 892 $\Omega$
Voltage at: 50 °C (122 °F)	1.7 V
Resistance at: 60 °C (140 °F)	526 ... 642 $\Omega$
Voltage at: 60 °C (140 °F)	1.4 V
Resistance at: 70 °C (158 °F)	385 ... 471 $\Omega$
Voltage at: 70 °C (158 °F)	1.0 V
Resistance at: 80 °C (176 °F)	286 ... 350 $\Omega$
Voltage at: 80 °C (176 °F)	0.86 V
Resistance at: 90 °C (194 °F)	216 ... 264 $\Omega$
Voltage at: 90 °C (194 °F)	0.68 V
Resistance at: 100 °C (212 °F)	165 ... 202 $\Omega$

### 3 ENGINE CONTROL TROUBLE CODE

Voltage at: 100 °C (212 °F)	0.6 V
Resistance at: 110 °C (230 °F)	128 ... 156 Ω
Voltage at: 110 °C (230 °F)	0.44 V
Resistance at: 120 °C (248 °F)	100 ... 122 Ω
Voltage at: 120 °C (248 °F)	0.34 V

- » If the specifications have not been met:
  - Change the coolant temperature sensor.
- » If the specifications have been met:
  - Check the next possible cause:  
Coolant temperature sensor – the signal wire has a short circuit to ground (terminal 31) (📖 p. 34)

#### Coolant temperature sensor – the signal wire has a short circuit to ground (terminal 31)

##### Condition

The diagnostics tool is disconnected.

Engine control unit is disconnected. (📖 p. 16)

The break out box is connected to the engine control unit wiring with adapter **00029095016**.

The coolant temperature sensor is disconnected. (📖 p. 9)

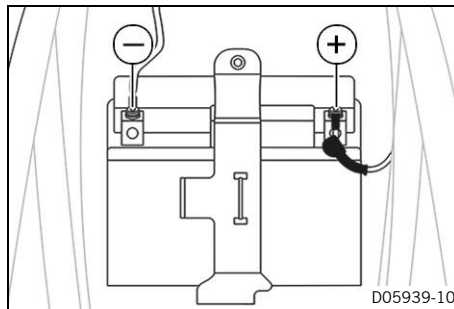
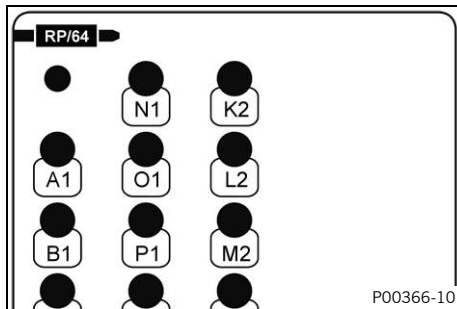

##### Coolant temperature sensor – check the signal wire for a short circuit to ground (terminal 31).

-  Measure the resistance between the specified points.  
Bob box connector **RP** pin **K3** – Measuring point **Ground (-)**

Resistance	$\infty$ Ω
------------	------------

- » If the specifications have not been met:
  - Check the cable from engine control unit connector **RP** (📖 p. 157) pin **K3** to connector **HV** (📖 p. 155) pin **1** for a short circuit to ground (terminal 31).
- » If the specifications have been met:
  - Check the next possible cause:  
Coolant temperature sensor – the signal wire has a short circuit to sensor ground (📖 p. 35)

## Coolant temperature sensor – the signal wire has a short circuit to sensor ground

### Condition

The diagnostics tool is disconnected.

Engine control unit is disconnected. (📖 p. 16)

The break out box is connected to the engine control unit wiring harness with adapter **00029095016**.

The coolant temperature sensor is disconnected. (📖 p. 9)

### Coolant temperature sensor – check the signal wire for a short circuit to sensor ground.

-  Measure the resistance between the specified points.  
Bob box connector **RP** pin **K3** – Bob box connector **RP** pin **J2**

Resistance	$\infty \Omega$
------------	-----------------

- » If the specifications have not been met:
  - Check cable from engine control unit connector **RP** (📖 p. 157) pin **K3** to connector **HV** (📖 p. 155) pin **1** for a short circuit to sensor ground.
- » If the specifications have been met:
  - Contact customer service.

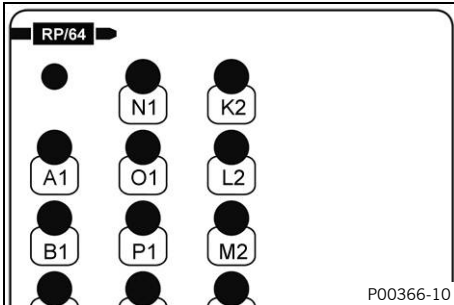

<b>Blink code for malfunction indicator lamp</b>	 12 Malfunction indicator lamp flashes 1x long, 2x short
<b>Display on diagnostic tool</b>	P011812 <b>"Coolant temperature sensor"</b> <b>"Input signal too high"</b>
<b>Error level condition</b>	Coolant temperature sensor – input signal too high Voltage: $\geq 4.8$ V Time: $\geq 3$ s
<b>Function check</b>	Coolant temperature sensor – checking the temperature (📖 p. 36)
<b>Possible cause</b>	Coolant temperature sensor – the value is not plausible (📖 p. 37)
	Coolant temperature sensor – the signal wire is faulty (📖 p. 38)
	Coolant temperature sensor – the ground wire is faulty (📖 p. 39)
	Coolant temperature sensor – the signal wire has a short circuit to plus (terminal 30) (📖 p. 39)
	Coolant temperature sensor – the signal wire has a short circuit to ignition plus (terminal 15) (📖 p. 40)
	Coolant temperature sensor – the signal wire has a short circuit to the sensor power supply (📖 p. 40)
<b>Last measure if none of the documented causes leads to elimination of the fault</b>	– Contact customer service.

## Coolant temperature sensor – checking the temperature

### Condition

The diagnostics tool is connected and running.

- Select **"Engine control unit" > "Measured values" > "Coolant temperature"**.

### Guideline

Engine temperature is plausible.

- » If the displayed value is equal to the setpoint value:
  - Clear the fault memory using the KTM diagnostics tool.
  - Take a test ride.
  - Read out the fault memory using the KTM diagnostics tool.
- » If the displayed value is above the setpoint value:
  - Check the next possible cause:  
Coolant temperature sensor – the value is not plausible (📖 p. 37)
  - Check the next possible cause:  
Coolant temperature sensor – the signal wire is faulty (📖 p. 38)
  - Check the next possible cause:  
Coolant temperature sensor – the ground wire is faulty (📖 p. 39)
  - Check the next possible cause:  
Coolant temperature sensor – the signal wire has a short circuit to plus (terminal 30) (📖 p. 39)
  - Check the next possible cause:  
Coolant temperature sensor – the signal wire has a short circuit to ignition plus (terminal 15) (📖 p. 40)
  - Check the next possible cause:  
Coolant temperature sensor – the signal wire has a short circuit to the sensor power supply (📖 p. 40)

## Coolant temperature sensor – the value is not plausible

### Condition

The diagnostics tool is disconnected.

The coolant temperature sensor is disconnected. (🔧 p. 9)

### Coolant temperature sensor – check the resistance.

- $\Omega$  Measure the resistance between the specified points.  
Coolant temperature sensor pin 1 – Coolant temperature sensor pin 2

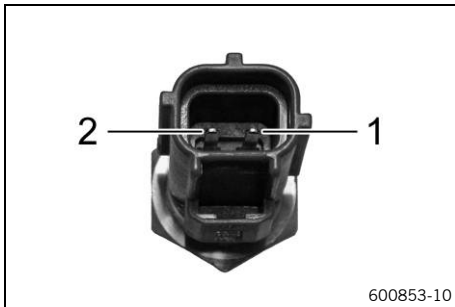

Coolant temperature sensor	
Resistance at: -20 °C (-4 °F)	13.50 ... 16.50 k $\Omega$
Voltage at: -20 °C (-4 °F)	4.5 V
Resistance at: -10 °C (14 °F)	8.24 ... 10.08 k $\Omega$
Voltage at: -10 °C (14 °F)	4.3 V
Resistance at: 0 °C (32 °F)	5.17 ... 6.31 k $\Omega$
Voltage at: 0 °C (32 °F)	3.9 V
Resistance at: 10 °C (50 °F)	3.33 ... 4.07 k $\Omega$
Voltage at: 10 °C (50 °F)	3.5 V
Resistance at: 20 °C (68 °F)	2.21 ... 2.70 k $\Omega$
Voltage at: 20 °C (68 °F)	3.1 V
Resistance at: 30 °C (86 °F)	1.49 ... 1.83 k $\Omega$
Voltage at: 30 °C (86 °F)	2.5 V
Resistance at: 40 °C (104 °F)	1.04 ... 1.27 k $\Omega$
Voltage at: 40 °C (104 °F)	2.1 V
Resistance at: 50 °C (122 °F)	730 ... 892 $\Omega$
Voltage at: 50 °C (122 °F)	1.7 V
Resistance at: 60 °C (140 °F)	526 ... 642 $\Omega$
Voltage at: 60 °C (140 °F)	1.4 V
Resistance at: 70 °C (158 °F)	385 ... 471 $\Omega$
Voltage at: 70 °C (158 °F)	1.0 V
Resistance at: 80 °C (176 °F)	286 ... 350 $\Omega$
Voltage at: 80 °C (176 °F)	0.86 V
Resistance at: 90 °C (194 °F)	216 ... 264 $\Omega$

### 3 ENGINE CONTROL TROUBLE CODE

Voltage at: 90 °C (194 °F)	0.68 V
Resistance at: 100 °C (212 °F)	165 ... 202 Ω
Voltage at: 100 °C (212 °F)	0.6 V
Resistance at: 110 °C (230 °F)	128 ... 156 Ω
Voltage at: 110 °C (230 °F)	0.44 V
Resistance at: 120 °C (248 °F)	100 ... 122 Ω
Voltage at: 120 °C (248 °F)	0.34 V

- » If the specifications have not been met:
  - Change the coolant temperature sensor.
- » If the specifications have been met:
  - Check the next possible cause:  
Coolant temperature sensor – the signal wire is faulty (🔧 p. 38)

#### Coolant temperature sensor – the signal wire is faulty

##### Condition

The diagnostics tool is disconnected.

Engine control unit is disconnected. (🔧 p. 16)

The break out box is connected to the engine control unit wiring harness with adapter **00029095016**.

The coolant temperature sensor is disconnected. (🔧 p. 9)

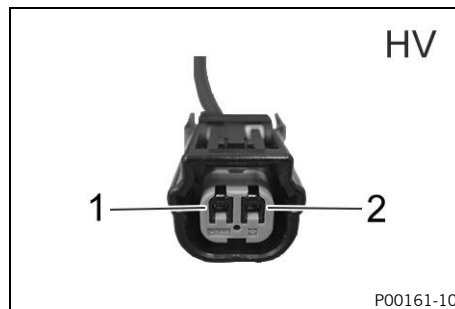
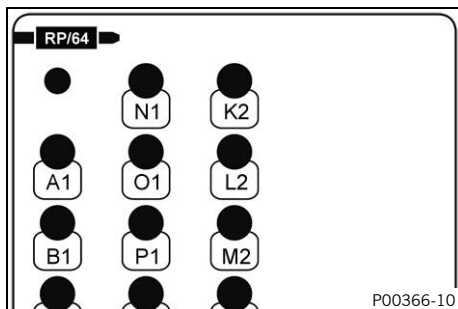

##### Coolant temperature sensor – check the signal wire.

-  Measure the resistance between the specified points.  
Bob box connector **RP** pin **K3** – Coolant temperature sensor connector **HV** pin **1**

Resistance	≤ 0.6 Ω
------------	---------

- » If the specifications have not been met:
  - Check engine control unit connector **RP** (🔧 p. 157) pin **K3** and connector **HV** (🔧 p. 155) pin **1**.
  - Check the cable from engine control unit connector **RP** (🔧 p. 157) pin **K3** to connector **HV** (🔧 p. 155) pin **1**.
- » If the specifications have been met:
  - Check the next possible cause:  
Coolant temperature sensor – the ground wire is faulty (🔧 p. 39)

## Coolant temperature sensor – the ground wire is faulty

### Condition

The diagnostics tool is disconnected.

Engine control unit is disconnected. (📖 p. 16)

The break out box is connected to the engine control unit wiring harness with adapter **00029095016**.

The coolant temperature sensor is disconnected. (📖 p. 9)

The intake air temperature sensor is disconnected. (📖 p. 12)

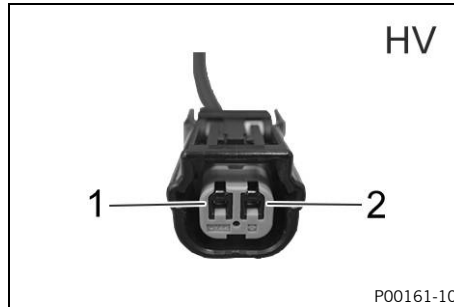
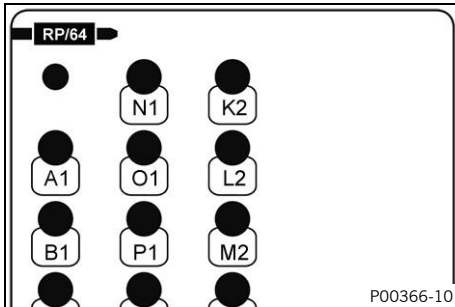

### Coolant temperature sensor – check the ground wire.

- Measure the resistance between the specified points.  
Bob box connector **RP** pin **J2** – Coolant temperature sensor connector **HV** pin **2**

Resistance	$\leq 0.6 \Omega$
------------	-------------------

- » If the specifications have not been met:
  - Check engine control unit connector **RP** (📖 p. 157) pin **J2** and connector **HV** (📖 p. 155) pin **2**.
  - Check the cable from engine control unit connector **RP** (📖 p. 157) pin **J2** to connector **HV** (📖 p. 155) pin **2**.
- » If the specifications have been met:
  - Check the next possible cause:  
Coolant temperature sensor – the signal wire has a short circuit to plus (terminal 30) (📖 p. 39)

## Coolant temperature sensor – the signal wire has a short circuit to plus (terminal 30)

### Condition

The diagnostics tool is disconnected.

Engine control unit is disconnected. (📖 p. 16)

The break out box is connected to the engine control unit wiring harness with adapter **00029095016**.

The coolant temperature sensor is disconnected. (📖 p. 9)

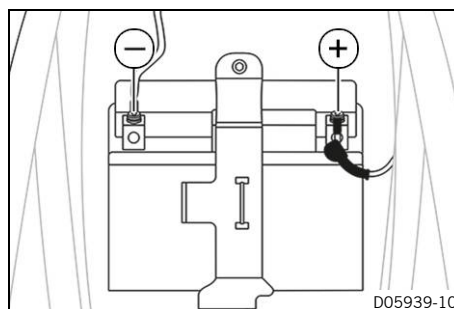
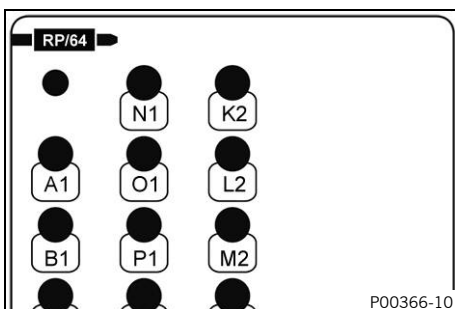

### Coolant temperature sensor – check the signal wire for a short circuit to plus (terminal 30).

- Measure the voltage between the specified points.  
Bob box connector **RP** pin **K3** – Measuring point **Ground (-)**

Voltage	$\leq 0.1 \text{ V}$
---------	----------------------

- » If the specifications have not been met:

### 3 ENGINE CONTROL TROUBLE CODE

- Check the cable from engine control unit connector **RP** (📖 p. 157) pin **K3** to connector **HV** (📖 p. 155) pin **1** for a short circuit to plus (terminal 30).
- » If the specifications have been met:
  - Check the next possible cause:
    - Coolant temperature sensor – the signal wire has a short circuit to ignition plus (terminal 15) (📖 p. 40)

#### Coolant temperature sensor – the signal wire has a short circuit to ignition plus (terminal 15)

##### Condition

The diagnostics tool is disconnected.

Engine control unit is disconnected. (📖 p. 16)

The break out box is connected to the engine control unit wiring harness with adapter **00029095016**.

The coolant temperature sensor is disconnected. (📖 p. 9)

##### Coolant temperature sensor – check the signal wire for a short circuit to ignition plus (terminal 15).

-  Measure the resistance between the specified points.  
Bob box connector **RP** pin **K3** – Bob box connector **RP** pin **D4**

Resistance	$\infty \Omega$
------------	-----------------

- » If the specifications have not been met:
  - Check the cable from engine control unit connector **RP** (📖 p. 157) pin **K3** to connector **HV** (📖 p. 155) pin **1** for a short circuit to ignition plus (terminal 15).
- » If the specifications have been met:
  - Check the next possible cause:
    - Coolant temperature sensor – the signal wire has a short circuit to the sensor power supply (📖 p. 40)

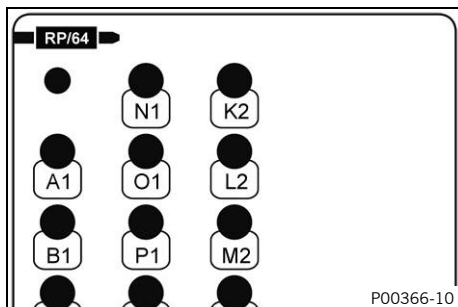

#### Coolant temperature sensor – the signal wire has a short circuit to the sensor power supply

##### Condition

The diagnostics tool is disconnected.

Engine control unit is disconnected. (📖 p. 16)

The break out box is connected to the engine control unit wiring harness with adapter **00029095016**.

The coolant temperature sensor is disconnected. (📖 p. 9)

##### Coolant temperature sensor – check the signal wire for a short circuit to the sensor power supply.

-  Measure the resistance between the specified points.  
Bob box connector **RP** pin **K3** – Bob box connector **RP** pin **D3**

Resistance	$\infty \Omega$
------------	-----------------

- » If the specifications have not been met:
  - Check the cable from engine control unit connector **RP** (📖 p. 157) pin **K3** to connector **HV** (📖 p. 155) pin **1** for a short circuit to the sensor power supply.
- » If the specifications have been met:
  - Contact customer service.

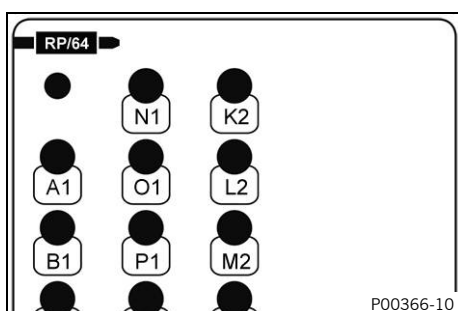

<b>Blink code for malfunction indicator lamp</b>	<div style="border: 1px solid black; padding: 2px; display: inline-block; font-weight: bold; font-size: 1.2em;">Fi</div> 06 Malfunction indicator lamp flashes 6x short
<b>Display on diagnostic tool</b>	P012211 <b>"Throttle valve position sensor circuit A"</b> <b>"Input signal too low"</b>
<b>Error level condition</b>	Throttle valve position sensor circuit A – input signal too low Voltage: $\leq 0.2$ V Time: $\geq 0.08$ s
<b>Function check</b>	Throttle valve position sensor circuit A - checking the voltage (📖 p. 41)
<b>Possible cause</b>	Throttle valve position sensor circuit A – the power supply is faulty (📖 p. 42)
	Throttle valve position sensor circuit A – signal wire is faulty (📖 p. 42)
	Throttle valve position sensor circuit A – the signal wire has a short circuit to ground (terminal 31) (📖 p. 43)
	Throttle valve position sensor circuit A – the signal wire has a short circuit to sensor ground (📖 p. 43)
<b>Last measure if none of the documented causes leads to elimination of the fault</b>	– Contact customer service.

### Throttle valve position sensor circuit A - checking the voltage

#### Condition

The diagnostics tool is connected and running.

- Select **"Engine control unit" > "Measured values" > "Throttle position sensor voltage"** and **"Throttle valve position"**.
- Slowly and evenly turn the throttle grip all the way.

Circuit A throttle valve position sensor	
Throttle valve position sensor voltage	0.52 ... 4.66 V

Circuit A throttle valve position sensor	
Throttle valve position	2.5 ... 84.5°

- » If the displayed value is equal to the setpoint value:
  - Clear the fault memory using the KTM diagnostics tool.
  - Take a test ride.
  - Read out the fault memory using the KTM diagnostics tool.
- » If the displayed value is below the setpoint value:
  - Check the next possible cause:  
Throttle valve position sensor circuit A – the power supply is faulty (📖 p. 42)
  - Check the next possible cause:  
Throttle valve position sensor circuit A – signal wire is faulty (📖 p. 42)
  - Check the next possible cause:  
Throttle valve position sensor circuit A – the signal wire has a short circuit to ground (terminal 31) (📖 p. 43)
  - Check the next possible cause:  
Throttle valve position sensor circuit A – the signal wire has a short circuit to sensor ground (📖 p. 43)

## Throttle valve position sensor circuit A – the power supply is faulty

### Condition

The diagnostics tool is connected and running.

Engine control unit is connected. (📖 p. 16)

Throttle valve position sensor circuit A is disconnected. (📖 p. 14)

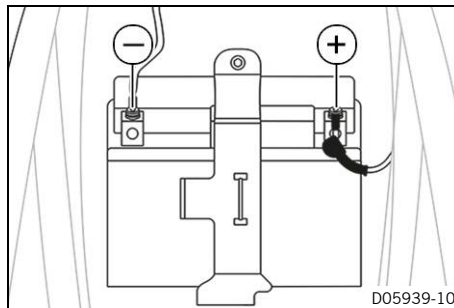
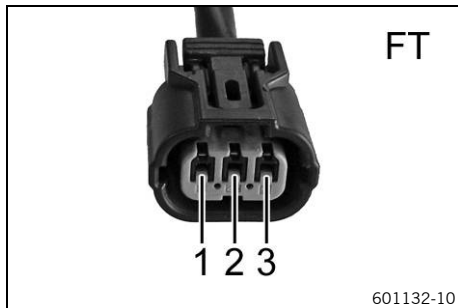

### Throttle valve position sensor circuit A – check the power supply.

- **V** Measure the voltage between the specified points.  
Throttle valve position sensor circuit A, connector **FT** pin **1** – Measuring point **Ground (-)**



### Info

For the measurement, the measuring points must be subjected to a 12 V/21 W bulb.

Voltage	4.9 ... 5.1 V
---------	---------------

- » If the specifications have not been met:
  - Check the cable from connector **FT** (📖 p. 154) pin **1** to engine control unit connector **RP** (📖 p. 157) pin **D2**.
- » If the specifications have been met:
  - Check the next possible cause:  
Throttle valve position sensor circuit A – signal wire is faulty (📖 p. 42)

## Throttle valve position sensor circuit A – signal wire is faulty

### Condition

The diagnostics tool is disconnected.

Engine control unit is disconnected. (📖 p. 16)

The break out box is connected to the engine control unit wiring harness with adapter **00029095016**.

Throttle valve position sensor circuit A is disconnected. (📖 p. 14)

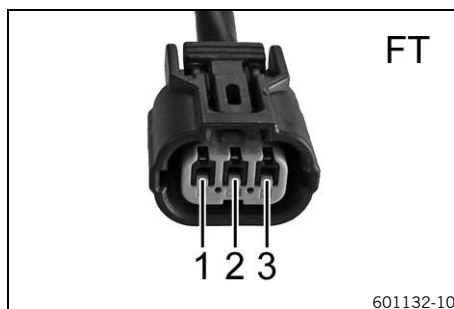
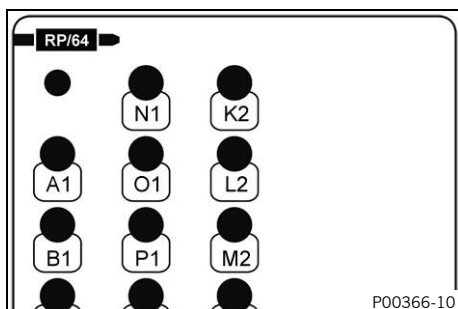

### Throttle valve position sensor circuit A – check the signal wire.

- **Ω** Measure the resistance between the specified points.  
Bob box connector **RP** pin **G3** – Throttle valve position sensor circuit A, connector **FT** pin **2**

Resistance	≤ 0.6 Ω
------------	---------

- » If the specifications have not been met:
  - Check engine control unit connector **RP** (📖 p. 157) pin **G3** and connector **FT** (📖 p. 154) pin **2**.
  - Check the cable from engine control unit connector **RP** (📖 p. 157) pin **G3** to connector **FT** (📖 p. 154) pin **2**.
- » If the specifications have been met:
  - Check the next possible cause:  
Throttle valve position sensor circuit A – the signal wire has a short circuit to ground (terminal 31) (📖 p. 43)

## Throttle valve position sensor circuit A – the signal wire has a short circuit to ground (terminal 31)

### Condition

The diagnostics tool is disconnected.

Engine control unit is disconnected. (📖 p. 16)

The break out box is connected to the engine control unit wiring harness with adapter **00029095016**.

Throttle valve position sensor circuit A is disconnected. (📖 p. 14)

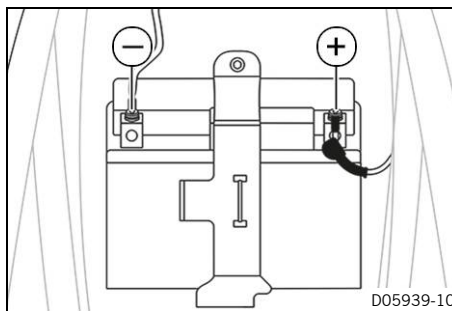
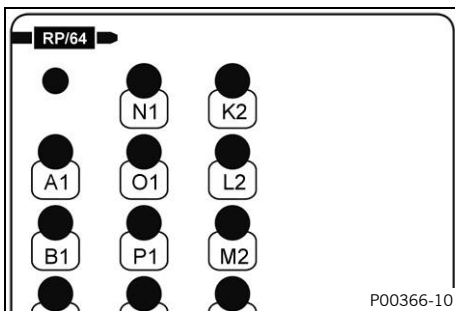

### Throttle valve position sensor circuit A – check the signal wire for a short circuit to ground (terminal 31).

- Measure the resistance between the specified points.  
Bob box connector **RP** pin **G3** – Measuring point **Ground (-)**

Resistance	$\infty \Omega$
------------	-----------------

- » If the specifications have not been met:
  - Check the cable from engine control unit connector **RP** (📖 p. 157) pin **G3** to connector **FT** (📖 p. 154) pin **2** for a short circuit to ground (terminal 31).
- » If the specifications have been met:
  - Check the next possible cause:  
Throttle valve position sensor circuit A – the signal wire has a short circuit to sensor ground (📖 p. 43)

## Throttle valve position sensor circuit A – the signal wire has a short circuit to sensor ground

### Condition

The diagnostics tool is disconnected.

Engine control unit is disconnected. (📖 p. 16)

The break out box is connected to the engine control unit wiring harness with adapter **00029095016**.

Throttle valve position sensor circuit A is disconnected. (📖 p. 14)

### 3 ENGINE CONTROL TROUBLE CODE

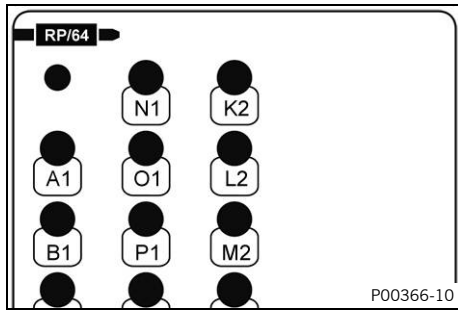

**Throttle valve position sensor circuit A – check the signal wire for a short circuit to sensor ground.**

-  Measure the resistance between the specified points.  
Bob box connector **RP** pin **G3** – Bob box connector **RP** pin **E2**

Resistance	$\infty \Omega$
------------	-----------------

- » If the specifications have not been met:
  - Check cable from engine control unit connector **RP** (📖 p. 157) pin **G3** to connector **FT** (📖 p. 154) pin **2** for a short circuit to sensor ground.
- » If the specifications have been met:
  - Contact customer service.

<b>Blink code for malfunction indicator lamp</b>	<b>Fi</b> 06 Malfunction indicator lamp flashes 6x short
<b>Display on diagnostic tool</b>	P012312 <b>"Throttle valve position sensor circuit A"</b> <b>"Input signal too high"</b>
<b>Error level condition</b>	Throttle valve position sensor circuit A – input signal too high Voltage: $\geq 4.7$ V Time: $\geq 0.08$ s
<b>Function check</b>	Throttle valve position sensor circuit A - checking the voltage (📖 p. 45)
<b>Possible cause</b>	Throttle valve position sensor circuit A – the signal wire has a short circuit to plus (terminal 30) (📖 p. 46) Throttle valve position sensor circuit A – the signal wire has a short circuit to ignition plus (terminal 15) (📖 p. 46) Throttle valve position sensor circuit A – the signal wire has a short circuit to the sensor power supply (📖 p. 47)
<b>Last measure if none of the documented causes leads to elimination of the fault</b>	– Contact customer service.

## Throttle valve position sensor circuit A - checking the voltage

### Condition

The diagnostics tool is connected and running.

- Select **"Engine control unit" > "Measured values" > "Throttle position sensor voltage"** and **"Throttle valve position"**.
- Slowly and evenly turn the throttle grip all the way.

Circuit A throttle valve position sensor	
Throttle valve position sensor voltage	0.52 ... 4.66 V

Circuit A throttle valve position sensor	
Throttle valve position	2.5 ... 84.5°

- » If the displayed value is equal to the setpoint value:
  - Clear the fault memory using the KTM diagnostics tool.
  - Take a test ride.
  - Read out the fault memory using the KTM diagnostics tool.
- » If the displayed value is above the setpoint value:
  - Check the next possible cause:  
Throttle valve position sensor circuit A – the signal wire has a short circuit to plus (terminal 30) (📖 p. 46)
  - Check the next possible cause:  
Throttle valve position sensor circuit A – the signal wire has a short circuit to ignition plus (terminal 15) (📖 p. 46)
  - Check the next possible cause:  
Throttle valve position sensor circuit A – the signal wire has a short circuit to the sensor power supply (📖 p. 47)

## Throttle valve position sensor circuit A – the signal wire has a short circuit to plus (terminal 30)

### Condition

The diagnostics tool is disconnected.

Engine control unit is disconnected. (📖 p. 16)

The break out box is connected to the engine control unit wiring harness with adapter **00029095016**.

Throttle valve position sensor circuit A is disconnected. (📖 p. 14)

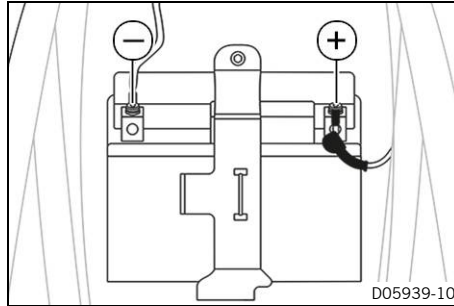
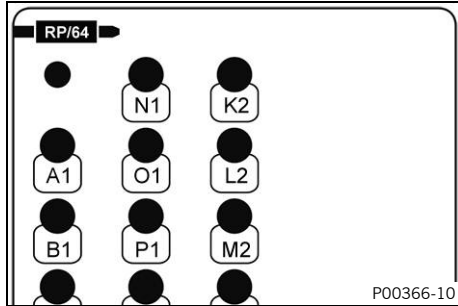

### Throttle valve position sensor circuit A – check the signal wire for a short circuit to plus (terminal 30).

- **V** Measure the voltage between the specified points.  
Bob box connector **RP** pin **G3** – Measuring point **Ground (-)**

Voltage	≤ 0.1 V
---------	---------

- » If the specifications have not been met:
  - Check the cable from engine control unit connector **RP** (📖 p. 157) pin **G3** to connector **FT** (📖 p. 154) pin **2** for a short circuit to plus (terminal 30).
- » If the specifications have been met:
  - Check the next possible cause:  
Throttle valve position sensor circuit A – the signal wire has a short circuit to ignition plus (terminal 15) (📖 p. 46)

## Throttle valve position sensor circuit A – the signal wire has a short circuit to ignition plus (terminal 15)

### Condition

The diagnostics tool is disconnected.

Engine control unit is disconnected. (📖 p. 16)

The break out box is connected to the engine control unit wiring harness with adapter **00029095016**.

Throttle valve position sensor circuit A is disconnected. (📖 p. 14)

### Throttle valve position sensor circuit A – check the signal wire for a short circuit to ignition plus (terminal 15).

- **Ω** Measure the resistance between the specified points.  
Bob box connector **RP** pin **G3** – Bob box connector **RP** pin **D4**

Resistance	∞ Ω
------------	-----

- » If the specifications have not been met:
  - Check the cable from engine control unit connector **RP** (📖 p. 157) pin **G3** to connector **FT** (📖 p. 154) pin **2** for a short circuit to ignition plus (terminal 15).
- » If the specifications have been met:
  - Check the next possible cause:  
Throttle valve position sensor circuit A – the signal wire has a short circuit to the sensor power supply (📖 p. 47)

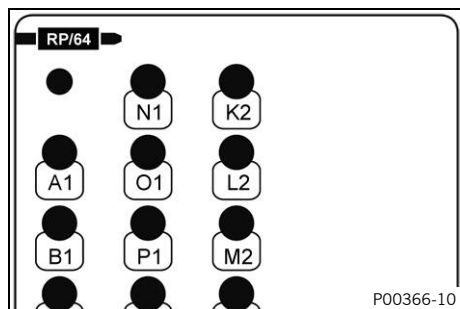

## Throttle valve position sensor circuit A – the signal wire has a short circuit to the sensor power supply

### Condition

The diagnostics tool is disconnected.

Engine control unit is disconnected. (📖 p. 16)

The break out box is connected to the engine control unit wiring harness with adapter **00029095016**.

Throttle valve position sensor circuit A is disconnected. (📖 p. 14)

### Throttle valve position sensor circuit A – check the signal wire for a short circuit to the sensor power supply.

-  Measure the resistance between the specified points.  
Bob box connector **RP** pin **G3** – Bob box connector **RP** pin **D2**

Resistance	$\infty \Omega$
------------	-----------------

- » If the specifications have not been met:
  - Check the cable from engine control unit connector **RP** (📖 p. 157) pin **G3** to connector **FT** (📖 p. 154) pin **2** for a short circuit to the sensor power supply.
- » If the specifications have been met:
  - Contact customer service.

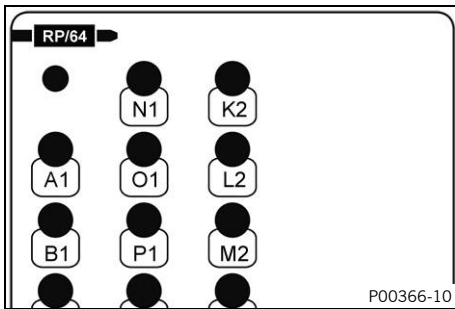

### 3 ENGINE CONTROL TROUBLE CODE

<b>Blink code for malfunction indicator lamp</b>	<b>Fi</b> 41 Malfunction indicator lamp flashes 4x long, 1x short
<b>Display on diagnostic tool</b>	P023111 <b>"Fuel pump"</b> <b>"Short circuit to ground or open circuit"</b>
<b>Error level condition</b>	Fuel pump - short circuit to ground/open circuit The engine is switched off: $\geq 0.4$ s
<b>Function check</b>	Checking the fuel pump (📖 p. 48)
<b>Possible cause</b>	Fuel pump – the value is not plausible (📖 p. 48)
	Fuel pump – the control wire is faulty (📖 p. 49)
	Fuel pump – supply wire resistance is too high (📖 p. 49)
	Fuel pump – the control wire has a short circuit to ground (terminal 31) (📖 p. 50)
	Fuel pump – the control wire has a short circuit to sensor ground (📖 p. 51)
<b>Last measure if none of the documented causes leads to elimination of the fault</b>	– Contact customer service.

#### Checking the fuel pump

##### Condition

The diagnostics tool is connected and running.

- Execute **"Engine control unit" > "Actuator test" > "Fuel pump"**.

Fuel pump	Operating noise
-----------	-----------------

- » If the specified value is reached:
  - Clear the fault memory using the KTM diagnostics tool.
  - Take a test ride.
  - Read out the fault memory using the KTM diagnostics tool.
- » If the specification is not reached:
  - Check the next possible cause:  
Fuel pump – the value is not plausible (📖 p. 48)
  - Check the next possible cause:  
Fuel pump – the control wire is faulty (📖 p. 49)
  - Check the next possible cause:  
Fuel pump – supply wire resistance is too high (📖 p. 49)
  - Check the next possible cause:  
Fuel pump – the control wire has a short circuit to ground (terminal 31) (📖 p. 50)
  - Check the next possible cause:  
Fuel pump – the control wire has a short circuit to sensor ground (📖 p. 51)

#### Fuel pump – the value is not plausible

##### Condition

The fuel pump is disconnected. (📖 p. 6) (All SX models)

The fuel pump is disconnected. (📖 p. 5) (All XC models)

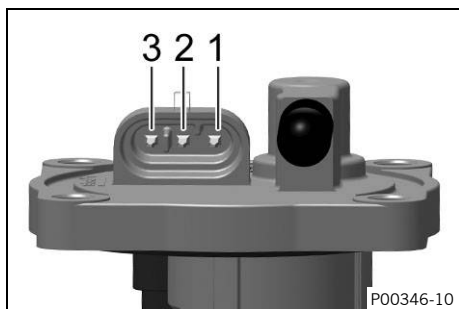

### Fuel pump - check the resistance.

- Measure the resistance between the specified points.  
Fuel pump pin 2 – Fuel pump pin 3

Fuel pump	
Resistance at: 20 °C (68 °F)	1.0 ... 1.8 Ω

- » If the specifications have not been met:
  - Change the fuel pump.
- » If the specifications have been met:
  - Check the next possible cause:  
Fuel pump – the control wire is faulty (📖 p. 49)

### Fuel pump – the control wire is faulty

#### Condition

The diagnostics tool is disconnected.

Engine control unit is disconnected. (📖 p. 16)

The break out box is connected to the engine control unit wiring harness with adapter **00029095016**.

The fuel pump is disconnected. (📖 p. 5) (All XC models)

The fuel pump is disconnected. (📖 p. 6) (All SX models)

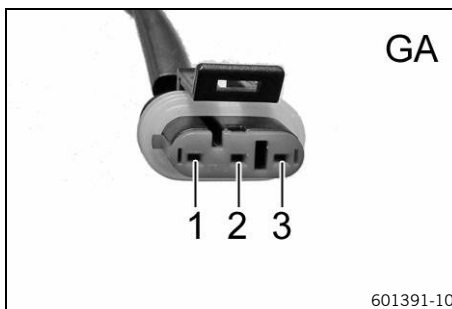
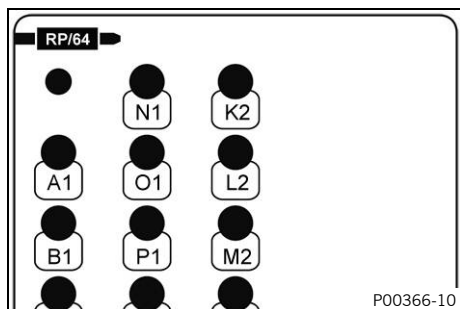

### Fuel pump – check the control wire.

- Measure the resistance between the specified points.  
Bob box connector **RP** pin **P3** – Fuel pump, connector **GA** pin **2**

Resistance	≤ 0.6 Ω
------------	---------

- » If the specifications have not been met:
  - Check engine control unit connector **RP** (📖 p. 157) pin **P3** and connector **GA** (📖 p. 155) pin **2**.
  - Check the cable from engine control unit connector **RP** (📖 p. 157) pin **P3** to connector **GA** (📖 p. 155) pin **2**.
- » If the specifications have been met:
  - Check the next possible cause:  
Fuel pump – supply wire resistance is too high (📖 p. 49)

### Fuel pump – supply wire resistance is too high

#### Condition

The diagnostics tool is disconnected.

The fuel pump is disconnected. (📖 p. 6) (All SX models)

The fuel pump is disconnected. (📖 p. 5) (All XC models)

### 3 ENGINE CONTROL TROUBLE CODE

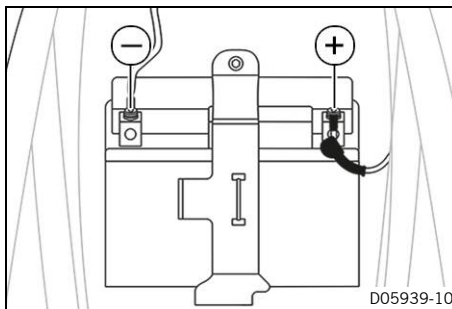
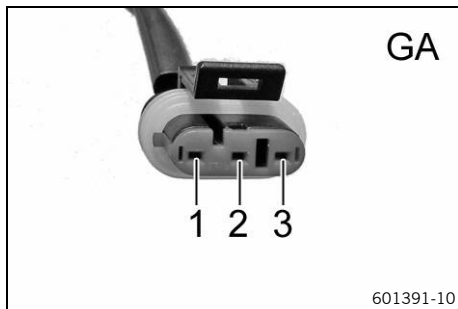

#### Fuel pump - check the load capacity of the supply wire.

- **V** Measure the voltage between the specified points.  
Fuel pump, connector **GA** pin **3** – Measuring point **Ground (-)**

#### **i** Info

For the measurement, the measuring points must be subjected to a 12 V/21 W bulb.

The value must not deviate from the battery voltage "VBAT" by more than 1 V.

- » If the specifications have not been met:
  - Check the fuses.
  - Check the wire from connector **GA** (📖 p. 155) pin **3** according to the wiring diagram.
- » If the specifications have been met:
  - Check the next possible cause:  
Fuel pump – the control wire has a short circuit to ground (terminal 31) (📖 p. 50)

#### Fuel pump – the control wire has a short circuit to ground (terminal 31)

#### Condition

The diagnostics tool is disconnected.

Engine control unit is disconnected. (📖 p. 16)

The break out box is connected to the engine control unit wiring harness with adapter **00029095016**.

The fuel pump is disconnected. (📖 p. 6) (All SX models)

The fuel pump is disconnected. (📖 p. 5) (All XC models)

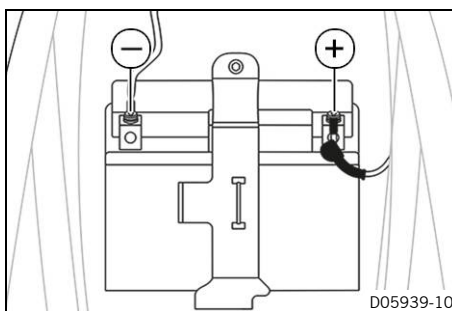
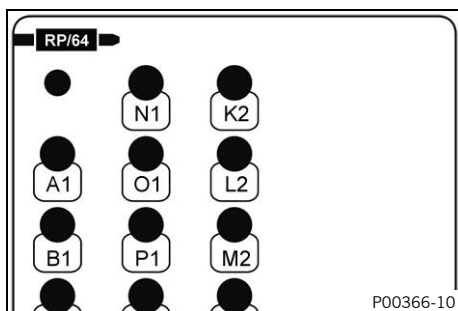

#### Fuel pump – check the control wire for a short circuit to ground (terminal 31).

- **Ω** Measure the resistance between the specified points.  
Bob box connector **RP** pin **P3** – Measuring point **Ground (-)**

Resistance

$\infty \Omega$

- » If the specifications have not been met:
  - Check the cable from engine control unit connector **RP** (📖 p. 157) pin **P3** to connector **GA** (📖 p. 155) pin **2** for a short circuit to ground (terminal 31).
- » If the specifications have been met:
  - Check the next possible cause:  
Fuel pump – the control wire has a short circuit to sensor ground (📖 p. 51)

## Fuel pump – the control wire has a short circuit to sensor ground

### Condition

The diagnostics tool is disconnected.

Engine control unit is disconnected. (📖 p. 16)

The break out box is connected to the engine control unit wiring harness with adapter **00029095016**.

The fuel pump is disconnected. (📖 p. 6) (All SX models)

The fuel pump is disconnected. (📖 p. 5) (All XC models)

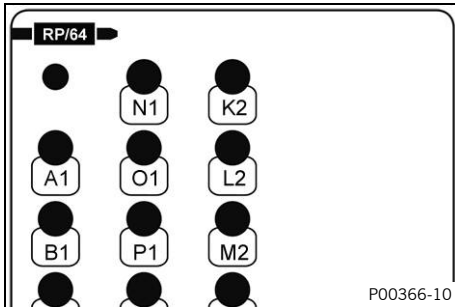

### Fuel pump – check the control wire for a short circuit to sensor ground.

-  Measure the resistance between the specified points.
  - Bob box connector **RP** pin **P3** – Bob box connector **RP** pin **E2**

Resistance	$\infty \Omega$
------------	-----------------

- » If the specifications have not been met:
  - Check cable from engine control unit connector **RP** (📖 p. 157) pin **P3** to connector **GA** (📖 p. 155) pin **2** for a short circuit to sensor ground.
- » If the specifications have been met:
  - Contact customer service.

### 3 ENGINE CONTROL TROUBLE CODE

<b>Blink code for malfunction indicator lamp</b>	<b>Fi</b> 41 Malfunction indicator lamp flashes 4x long, 1x short
<b>Display on diagnostic tool</b>	P023212 "Fuel pump" "Short circuit to plus"
<b>Error level condition</b>	Fuel pump – short circuit to plus The engine is switched off: $\geq 0.4$ s
<b>Function check</b>	Checking the fuel pump (📖 p. 52)
<b>Possible cause</b>	Fuel pump – the control wire has a short circuit to plus (terminal 30) (📖 p. 52)
<b>Last measure if none of the documented causes leads to elimination of the fault</b>	– Contact customer service.

#### Checking the fuel pump

##### Condition

The diagnostics tool is connected and running.

- Execute **"Engine control unit" > "Actuator test" > "Fuel pump"**.

Fuel pump	Operating noise
-----------	-----------------

- » If the specified value is reached:
    - Clear the fault memory using the KTM diagnostics tool.
    - Take a test ride.
    - Read out the fault memory using the KTM diagnostics tool.
  - » If the specification is not reached:
    - Check the next possible cause:  
Fuel pump – the control wire has a short circuit to plus (terminal 30) (📖 p. 52)
- Last measure if none of the documented causes leads to elimination of the fault
- Contact customer service.

#### Fuel pump – the control wire has a short circuit to plus (terminal 30)

##### Condition

The diagnostics tool is disconnected.

Engine control unit is disconnected. (📖 p. 16)

The break out box is connected to the engine control unit wiring harness with adapter **00029095016**.

The fuel pump is disconnected. (📖 p. 6) (All SX models)

The fuel pump is disconnected. (📖 p. 5) (All XC models)

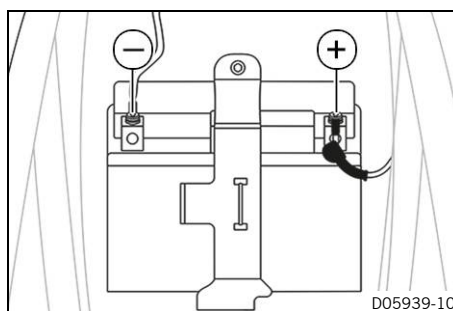
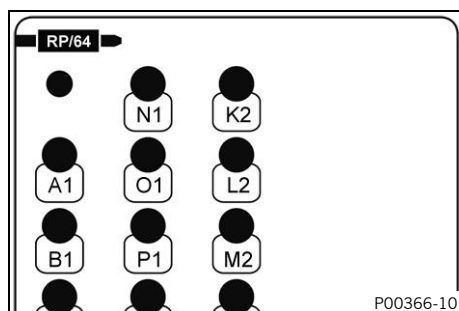

#### Fuel pump – check the control wire for a short circuit to plus (terminal 30).

-  Measure the resistance between the specified points.  
Bob box connector **RP** pin **P3** – Measuring point **plus (+)**

Resistance	$\infty \Omega$
------------	-----------------

- » If the specifications have not been met:
  - Check the cable from engine control unit connector **RP** (📖 p. 157) pin **P3** to connector **GA** (📖 p. 155) pin **2** for a short circuit to ground (terminal 31).
- » If the specifications have been met:
  - Contact customer service.

### 3 ENGINE CONTROL TROUBLE CODE

<b>Blink code for malfunction indicator lamp</b>	<b>Fi</b> 33 Malfunction indicator lamp flashes 3x long, 3x short
<b>Display on diagnostic tool</b>	P026111 "Injection valve 1, cylinder 1" "Input signal too low"
<b>Error level condition</b>	Injection valve 1, cylinder 1 – input signal too low Time: ≥ 1 s
<b>Function check</b>	Injection valve 1, cylinder 1 - checking the control (🔧 p. 54)
<b>Possible cause</b>	Injection valve 1, cylinder 1 – the value is not plausible (🔧 p. 54)
	Injection valve 1, cylinder 1 – the power supply is faulty (🔧 p. 55)
	Injection valve 1, cylinder 1 – the control wire is faulty (🔧 p. 56)
	Injection valve 1, cylinder 1 – the control wire has a short circuit to ground (terminal 31) (🔧 p. 56)
	Injection valve 1, cylinder 1 – the control wire has a short circuit to sensor ground (🔧 p. 57)
<b>Last measure if none of the documented causes leads to elimination of the fault</b>	– Contact customer service.

#### Injection valve 1, cylinder 1 - checking the control

##### Condition

The diagnostics tool is connected and running.

- Execute "Engine control unit" > "Actuator test" > "Injection valve 1".

Injection valve	Operating noise
-----------------	-----------------

- » If the specified value is reached:
  - Clear the fault memory using the KTM diagnostics tool.
  - Take a test ride.
  - Read out the fault memory using the KTM diagnostics tool.
- » If the specification is not reached:
  - Check the next possible cause:  
Injection valve 1, cylinder 1 – the value is not plausible (🔧 p. 54)
  - Check the next possible cause:  
Injection valve 1, cylinder 1 – the power supply is faulty (🔧 p. 55)
  - Check the next possible cause:  
Injection valve 1, cylinder 1 – the control wire is faulty (🔧 p. 56)
  - Check the next possible cause:  
Injection valve 1, cylinder 1 – the control wire has a short circuit to ground (terminal 31) (🔧 p. 56)
  - Check the next possible cause:  
Injection valve 1, cylinder 1 – the control wire has a short circuit to sensor ground (🔧 p. 57)

#### Injection valve 1, cylinder 1 – the value is not plausible

##### Condition

Injection valve 1, cylinder 1 is disconnected. (🔧 p. 13)

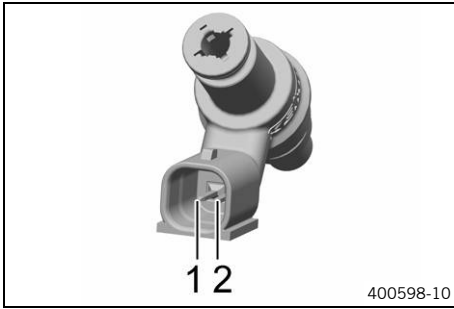

### Injection valve 1, cylinder 1 – check the resistance.

- Measure the resistance between the specified points.  
Injection valves, cylinder 1 pin 1 – Injection valves, cylinder 1 pin 2

Injection valve	
Resistance at: 20 °C (68 °F)	11.4 ... 12.6 Ω

- » If the specifications have not been met:
  - Change injection valve 1.
- » If the specifications have been met:
  - Check the next possible cause:  
Injection valve 1, cylinder 1 – the power supply is faulty (🔧 p. 55)

### Injection valve 1, cylinder 1 – the power supply is faulty

#### Condition

The diagnostics tool is connected and running.  
Engine control unit is connected. (🔧 p. 16)  
Injection valve 1, cylinder 1 is disconnected. (🔧 p. 13)

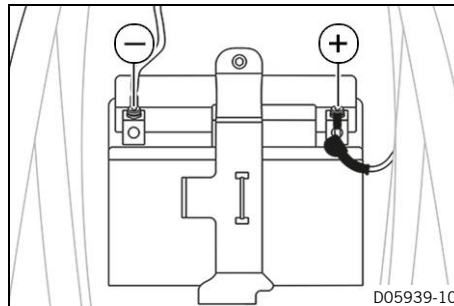
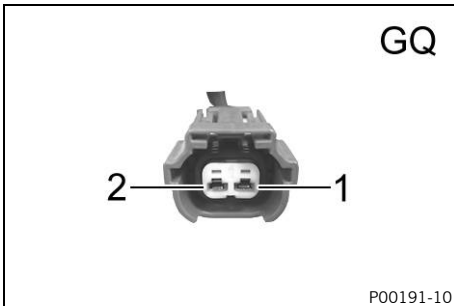

### Injection valve 1, cylinder 1 – check the power supply.

- Measure the voltage between the specified points.  
Injection valve 1, cylinder 1, connector **GQ** pin 2 – Measuring point **Ground (-)**

#### Info

For the measurement, the measuring points must be subjected to a 12 V/21 W bulb.

The value must not deviate from the battery voltage "VBAT" by more than 1 V.

- » If the specifications have not been met:
  - Check connector **GQ** (🔧 p. 155) pin 2.
  - Check the cable from connector **GQ** (🔧 p. 155) pin 2 to the next node in the wiring harness.
- » If the specifications have been met:
  - Check the next possible cause:  
Injection valve 1, cylinder 1 – the control wire is faulty (🔧 p. 56)

## Injection valve 1, cylinder 1 – the control wire is faulty

### Condition

The diagnostics tool is disconnected.

Engine control unit is disconnected. (📖 p. 16)

The break out box is connected to the engine control unit wiring harness with adapter **00029095016**.

Injection valve 1, cylinder 1 is disconnected. (📖 p. 13)

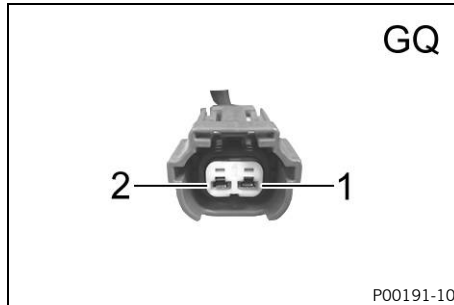
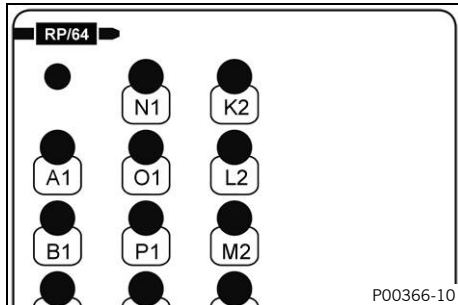

### Injection valve 1, cylinder 1 – check the control wire.

- Measure the resistance between the specified points.  
Bob box connector **RP** pin **N4** – Injection valve 1, cylinder 1, connector **GQ** pin **1**

Resistance	≤ 0.6 Ω
------------	---------

- » If the specifications have not been met:
  - Check engine control unit connector **RP** (📖 p. 157) pin **N4** and connector **GQ** (📖 p. 155) pin **1**.
  - Check the cable from engine control unit connector **RP** (📖 p. 157) pin **N4** to connector **GQ** (📖 p. 155) pin **1**.
- » If the specifications have been met:
  - Check the next possible cause:  
Injection valve 1, cylinder 1 – the control wire has a short circuit to ground (terminal 31) (📖 p. 56)

## Injection valve 1, cylinder 1 – the control wire has a short circuit to ground (terminal 31)

### Condition

The diagnostics tool is disconnected.

Engine control unit is disconnected. (📖 p. 16)

The break out box is connected to the engine control unit wiring harness with adapter **00029095016**.

Injection valve 1, cylinder 1 is disconnected. (📖 p. 13)

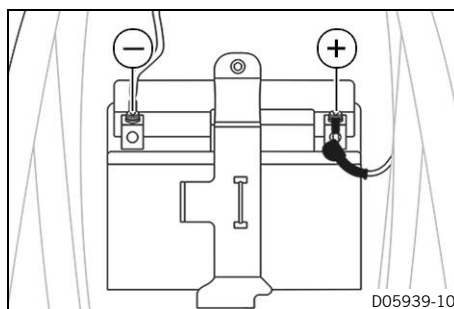
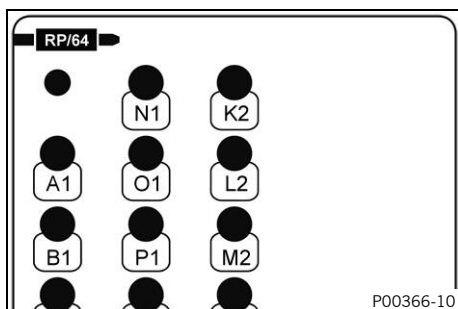

### Injection valve 1, cylinder 1 – check the control wire for a short circuit to ground (terminal 31).

- Measure the resistance between the specified points.  
Bob box connector **RP** pin **N4** – Measuring point **Ground (-)**

Resistance	∞ Ω
------------	-----

- » If the specifications have not been met:

- Check the cable from engine control unit connector **RP** (📖 p. 157) pin **N4** to connector **GQ** (📖 p. 155) pin **1** for a short circuit to ground (terminal 31).
- » If the specifications have been met:
  - Check the next possible cause:
    - Injection valve 1, cylinder 1 – the control wire has a short circuit to sensor ground (📖 p. 57)

## Injection valve 1, cylinder 1 – the control wire has a short circuit to sensor ground

### Condition

The diagnostics tool is disconnected.

Engine control unit is disconnected. (📖 p. 16)

The break out box is connected to the engine control unit wiring harness with adapter **00029095016**.

Injection valve 1, cylinder 1 is disconnected. (📖 p. 13)

### Injection valve 1, cylinder 1 – check the control wire for a short circuit to sensor ground.

-  Measure the resistance between the specified points.  
Bob box connector **RP** pin **N4** – Bob box connector **RP** pin **E2**

Resistance	$\infty \Omega$
------------	-----------------

- » If the specifications have not been met:
  - Check cable from engine control unit connector **RP** (📖 p. 157) pin **N4** to connector **GQ** (📖 p. 155) pin **1** for a short circuit to sensor ground.
- » If the specifications have been met:
  - Contact customer service.

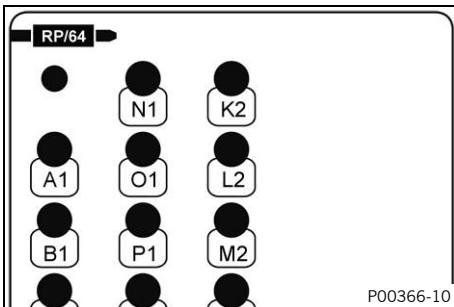

### 3 ENGINE CONTROL TROUBLE CODE

<b>Blink code for malfunction indicator lamp</b>	<b>Fi</b> 33 Malfunction indicator lamp flashes 3x long, 3x short
<b>Display on diagnostic tool</b>	P026212 "Injection valve 1, cylinder 1" "Input signal too high"
<b>Error level condition</b>	Injection valve 1, cylinder 1 – input signal too high Time: ≥ 1 s
<b>Function check</b>	Injection valve 1, cylinder 1 - checking the control (📖 p. 58)
<b>Possible cause</b>	Injection valve 1, cylinder 1 – the value is not plausible (📖 p. 58)
	Injection valve 1, cylinder 1 – the control wire has a short circuit to plus (terminal 30) (📖 p. 59)
	Injection valve 1, cylinder 1 – the control wire has a short circuit to ignition plus (terminal 15) (📖 p. 59)
	Injection valve 1, cylinder 1 – the control wire has a short circuit to the sensor power supply (📖 p. 60)
<b>Last measure if none of the documented causes leads to elimination of the fault</b>	– Contact customer service.

#### Injection valve 1, cylinder 1 - checking the control

##### Condition

The diagnostics tool is connected and running.

- Execute **"Engine control unit" > "Actuator test" > "Injection valve 1"**.

Injection valve	Operating noise
-----------------	-----------------

- » If the specified value is reached:
  - Clear the fault memory using the KTM diagnostics tool.
  - Take a test ride.
  - Read out the fault memory using the KTM diagnostics tool.
- » If the specification is not reached:
  - Check the next possible cause:  
Injection valve 1, cylinder 1 – the value is not plausible (📖 p. 58)
  - Check the next possible cause:  
Injection valve 1, cylinder 1 – the control wire has a short circuit to plus (terminal 30) (📖 p. 59)
  - Check the next possible cause:  
Injection valve 1, cylinder 1 – the control wire has a short circuit to ignition plus (terminal 15) (📖 p. 59)
  - Check the next possible cause:  
Injection valve 1, cylinder 1 – the control wire has a short circuit to the sensor power supply (📖 p. 60)

#### Injection valve 1, cylinder 1 – the value is not plausible

##### Condition

Injection valve 1, cylinder 1 is disconnected. (📖 p. 13)

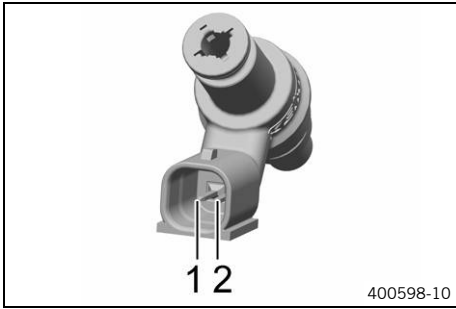

### Injection valve 1, cylinder 1 – check the resistance.

- $\Omega$  Measure the resistance between the specified points.  
Injection valves, cylinder 1 pin 1 – Injection valves, cylinder 1 pin 2

Injection valve	
Resistance at: 20 °C (68 °F)	11.4 ... 12.6 $\Omega$

- » If the specifications have not been met:
  - Change injection valve 1.
- » If the specifications have been met:
  - Check the next possible cause:  
Injection valve 1, cylinder 1 – the control wire has a short circuit to plus (terminal 30) (p. 59)

### Injection valve 1, cylinder 1 – the control wire has a short circuit to plus (terminal 30)

#### Condition

The diagnostics tool is disconnected.  
 Engine control unit is disconnected. (p. 16)  
 The break out box is connected to the engine control unit wiring harness with adapter **00029095016**.  
 Injection valve 1, cylinder 1 is disconnected. (p. 13)

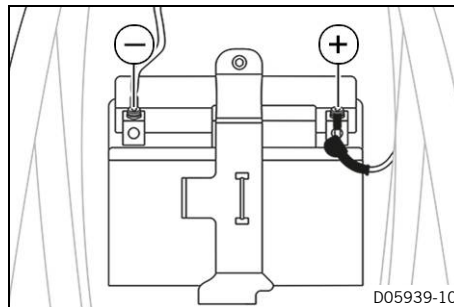
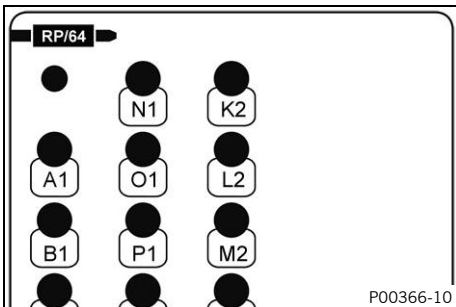

### Injection valve 1, cylinder 1 - check the control wire for a short circuit to plus (terminal 30).

- **V** Measure the voltage between the specified points.  
Bob box connector **RP** pin **N4** – Measuring point **Ground (-)**

Voltage	< 0.1 V
---------	---------

- » If the specifications have not been met:
  - Check the cable from engine control unit connector **RP** (p. 157) pin **N4** to connector **GQ** (p. 155) pin **1** for a short circuit to plus (terminal 30).
- » If the specifications have been met:
  - Check the next possible cause:  
Injection valve 1, cylinder 1 – the control wire has a short circuit to ignition plus (terminal 15) (p. 59)

### Injection valve 1, cylinder 1 – the control wire has a short circuit to ignition plus (terminal 15)

#### Condition

The diagnostics tool is disconnected.  
 Engine control unit is disconnected. (p. 16)  
 The break out box is connected to the engine control unit wiring harness with adapter **00029095016**.  
 Injection valve 1, cylinder 1 is disconnected. (p. 13)

### 3 ENGINE CONTROL TROUBLE CODE

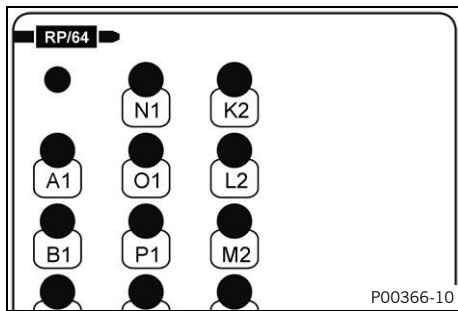

#### Injection valve 1, cylinder 1 – check the control wire for a short circuit to ignition plus (terminal 15).

- Measure the resistance between the specified points.  
Bob box connector **RP** pin **N4** – Bob box connector **RP** pin **D4**

Resistance	$\infty \Omega$
------------	-----------------

- » If the specifications have not been met:
  - Check the cable from engine control unit connector **RP** (📖 p. 157) pin **N4** to connector **GQ** (📖 p. 155) pin **T** for a short circuit to ignition plus (terminal 15).
- » If the specifications have been met:
  - Check the next possible cause:  
Injection valve 1, cylinder 1 – the control wire has a short circuit to the sensor power supply (📖 p. 60)

#### Injection valve 1, cylinder 1 – the control wire has a short circuit to the sensor power supply

##### Condition

The diagnostics tool is disconnected.

Engine control unit is disconnected. (📖 p. 16)

The break out box is connected to the engine control unit wiring harness with adapter **00029095016**.

Injection valve 1, cylinder 1 is disconnected. (📖 p. 13)

#### Injection valve 1, cylinder 1 – check the control wire for a short circuit to the sensor power supply.

- Measure the resistance between the specified points.  
Bob box connector **RP** pin **N4** – Bob box connector **RP** pin **D3**

Resistance	$\infty \Omega$
------------	-----------------

- » If the specifications have not been met:
  - Check the cable from engine control unit connector **RP** (📖 p. 157) pin **N4** to connector **GQ** (📖 p. 155) pin **T** for a short circuit to the sensor power supply.
- » If the specifications have been met:
  - Contact customer service.

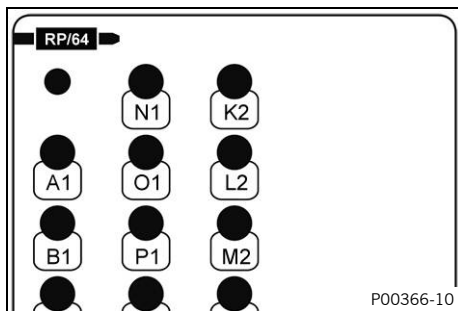

<b>Blink code for malfunction indicator lamp</b>	<b>Fi</b> 34 Malfunction indicator lamp flashes 3x long, 4x short
<b>Display on diagnostic tool</b>	P026411 "Injection valve 2, cylinder 1" "Input signal too low"
<b>Error level condition</b>	Injection valve 2, cylinder 1 – input signal too low Time: ≥ 1 s
<b>Function check</b>	Injection valve 2, cylinder 1 - checking the control (📖 p. 61)
<b>Possible cause</b>	Injection valve 2, cylinder 1 – the value is not plausible (📖 p. 61)
	Injection valve 2, cylinder 1 – the power supply is faulty (📖 p. 62)
	Injection valve 2, cylinder 1 – the control wire is faulty (📖 p. 63)
	Injection valve 2, cylinder 1 – the control wire has a short circuit to ground (terminal 31) (📖 p. 63)
	Injection valve 2, cylinder 1 - the control wire has a short circuit to sensor ground (📖 p. 64)
<b>Last measure if none of the documented causes leads to elimination of the fault</b>	– Contact customer service.

## Injection valve 2, cylinder 1 - checking the control

### Condition

The diagnostics tool is connected and running.

- Execute "Engine control unit" > "Actuator test" > "Injection valve 2".

Injection valve	Operating noise
-----------------	-----------------

- » If the specified value is reached:
  - Clear the fault memory using the KTM diagnostics tool.
  - Take a test ride.
  - Read out the fault memory using the KTM diagnostics tool.
- » If the specification is not reached:
  - Check the next possible cause:  
Injection valve 2, cylinder 1 – the value is not plausible (📖 p. 61)
  - Check the next possible cause:  
Injection valve 2, cylinder 1 – the power supply is faulty (📖 p. 62)
  - Check the next possible cause:  
Injection valve 2, cylinder 1 – the control wire is faulty (📖 p. 63)
  - Check the next possible cause:  
Injection valve 2, cylinder 1 – the control wire has a short circuit to ground (terminal 31) (📖 p. 63)
  - Check the next possible cause:  
Injection valve 2, cylinder 1 - the control wire has a short circuit to sensor ground (📖 p. 64)

## Injection valve 2, cylinder 1 – the value is not plausible

### Condition

Injection valve 2, cylinder 1 is disconnected. (📖 p. 13)

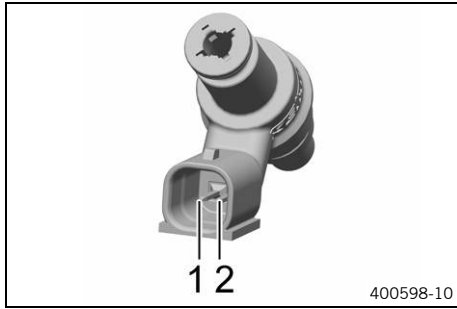

### Injection valve 2, cylinder 1 – check the resistance.

-  Measure the resistance between the specified points.  
Injection valves, cylinder 1 pin 1 – Injection valves, cylinder 1 pin 2

Injection valve	
Resistance at: 20 °C (68 °F)	11.4 ... 12.6 Ω

- » If the specifications have not been met:
  - Change injection valve 2.
- » If the specifications have been met:
  - Check the next possible cause:  
Injection valve 2, cylinder 1 – the power supply is faulty ( p. 62)

### Injection valve 2, cylinder 1 – the power supply is faulty

#### Condition

The diagnostics tool is connected and running.

Engine control unit is connected. ( p. 16)

Injection valve 2, cylinder 1 is disconnected. ( p. 13)

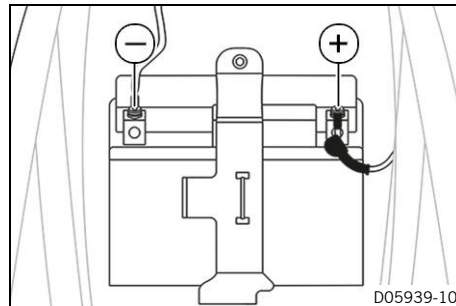
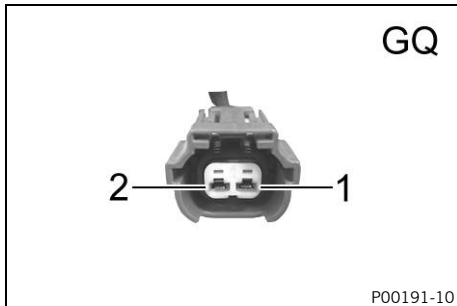



### Injection valve 2, cylinder 1 – check the power supply.

-  Measure the voltage between the specified points.  
Injection valve 2, cylinder 1, connector **GQ** pin 2 – Measuring point **Ground (-)**

#### Info

For the measurement, the measuring points must be subjected to a 12 V/21 W bulb.

The value must not deviate from the battery voltage "VBAT" by more than 1 V.

- » If the specifications have not been met:
  - Check connector **GQ** ( p. 155) pin 2.
  - Check the cable from connector **GQ** ( p. 155) pin 2 to the next node in the wiring harness.
- » If the specifications have been met:
  - Check the next possible cause:  
Injection valve 2, cylinder 1 – the control wire is faulty ( p. 63)

## Injection valve 2, cylinder 1 – the control wire is faulty

### Condition

The diagnostics tool is disconnected.

Engine control unit is disconnected. (📖 p. 16)

The break out box is connected to the engine control unit wiring harness with adapter **00029095016**.

Injection valve 2, cylinder 1 is disconnected. (📖 p. 13)

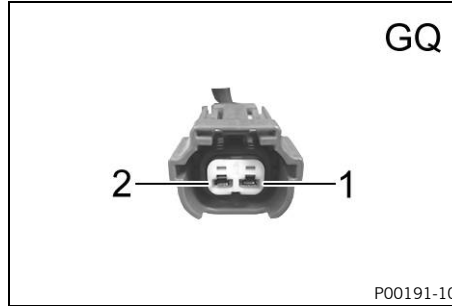
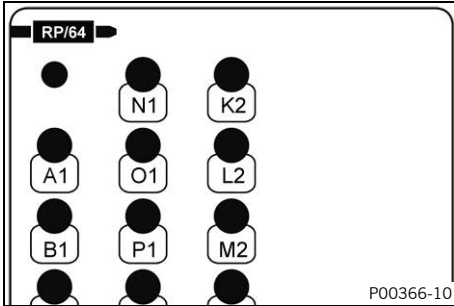

### Injection valve 2, cylinder 1 – check the control wire.

- Measure the resistance between the specified points.  
Bob box connector **RP** pin **M3** – Injection valve 2, cylinder 1, connector **GQ** pin **1**

Resistance	$\leq 0.6 \Omega$
------------	-------------------

- » If the specifications have not been met:
  - Check engine control unit connector **RP** (📖 p. 157) pin **M3** and connector **GQ** (📖 p. 155) pin **1**.
  - Check the cable from engine control unit connector **RP** (📖 p. 157) pin **M3** to connector **GQ** (📖 p. 155) pin **1**.
- » If the specifications have been met:
  - Check the next possible cause:  
Injection valve 2, cylinder 1 – the control wire has a short circuit to ground (terminal 31) (📖 p. 63)

## Injection valve 2, cylinder 1 – the control wire has a short circuit to ground (terminal 31)

### Condition

The diagnostics tool is disconnected.

Engine control unit is disconnected. (📖 p. 16)

The break out box is connected to the engine control unit wiring harness with adapter **00029095016**.

Injection valve 2, cylinder 1 is disconnected. (📖 p. 13)

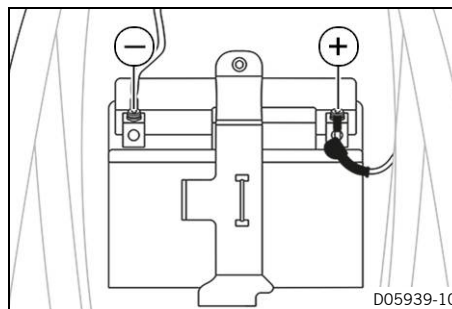
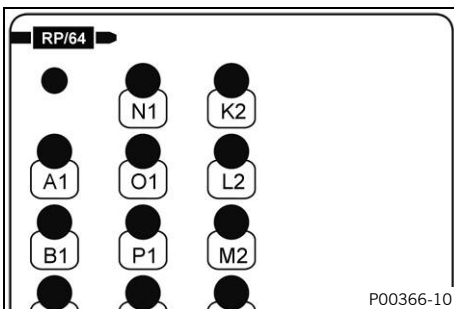

### Injection valve 2, cylinder 1 – check the control wire for a short circuit to ground (terminal 31).

- Measure the resistance between the specified points.  
Bob box connector **RP** pin **M3** – Measuring point **Ground (-)**

Resistance	$\infty \Omega$
------------	-----------------

- » If the specifications have not been met:

### 3 ENGINE CONTROL TROUBLE CODE

- Check the cable from engine control unit connector **RP** (📖 p. 157) pin **M3** to connector **GQ** (📖 p. 155) pin **1** for a short circuit to ground (terminal 31).
- » If the specifications have been met:
  - Check the next possible cause:  
Injection valve 2, cylinder 1 - the control wire has a short circuit to sensor ground (📖 p. 64)

#### Injection valve 2, cylinder 1 - the control wire has a short circuit to sensor ground

##### Condition

The diagnostics tool is disconnected.

Engine control unit is disconnected. (📖 p. 16)

The break out box is connected to the engine control unit wiring harness with adapter **00029095016**.

Injection valve 2, cylinder 1 is disconnected. (📖 p. 13)

##### Injection valve 2, cylinder 1 – check the control wire for a short circuit to sensor ground.

-  Measure the resistance between the specified points.  
Bob box connector **RP** pin **M3** – Bob box connector **RP** pin **E2**

Resistance	$\infty \Omega$
------------	-----------------

- » If the specifications have not been met:
  - Check cable from engine control unit connector **RP** (📖 p. 157) pin **M3** to connector **GQ** (📖 p. 155) pin **1** for a short circuit to sensor ground.
- » If the specifications have been met:
  - Contact customer service.

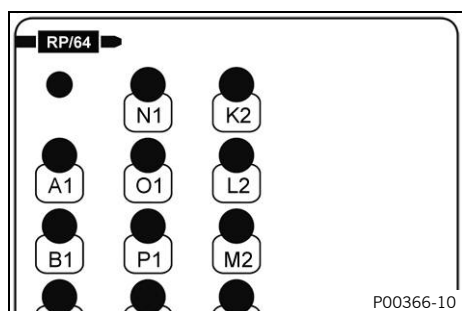

<b>Blink code for malfunction indicator lamp</b>	<b>Fi</b> 34 Malfunction indicator lamp flashes 3x long, 4x short
<b>Display on diagnostic tool</b>	P026512 "Injection valve 2, cylinder 1" "Input signal too high"
<b>Error level condition</b>	Injection valve 2, cylinder 1 – input signal too high Time: ≥ 1 s
<b>Function check</b>	Injection valve 2, cylinder 1 - checking the control (📖 p. 65)
<b>Possible cause</b>	Injection valve 2, cylinder 1 – the value is not plausible (📖 p. 65)
	Injection valve 2, cylinder 1 – the control wire has a short circuit to plus (terminal 30) (📖 p. 66)
	Injection valve 2, cylinder 1 – the control wire has a short circuit to ignition plus (terminal 15) (📖 p. 66)
	Injection valve 2, cylinder 1 – the control wire has a short circuit to the sensor power supply (📖 p. 67)
<b>Last measure if none of the documented causes leads to elimination of the fault</b>	– Contact customer service.

## Injection valve 2, cylinder 1 - checking the control

### Condition

The diagnostics tool is connected and running.

- Execute "Engine control unit" > "Actuator test" > "Injection valve 2".

Injection valve	Operating noise
-----------------	-----------------

- » If the specified value is reached:
  - Clear the fault memory using the KTM diagnostics tool.
  - Take a test ride.
  - Read out the fault memory using the KTM diagnostics tool.
- » If the specification is not reached:
  - Check the next possible cause:  
Injection valve 2, cylinder 1 – the value is not plausible (📖 p. 65)
  - Check the next possible cause:  
Injection valve 2, cylinder 1 – the control wire has a short circuit to plus (terminal 30) (📖 p. 66)
  - Check the next possible cause:  
Injection valve 2, cylinder 1 – the control wire has a short circuit to ignition plus (terminal 15) (📖 p. 66)
  - Check the next possible cause:  
Injection valve 2, cylinder 1 – the control wire has a short circuit to the sensor power supply (📖 p. 67)

## Injection valve 2, cylinder 1 – the value is not plausible

### Condition

Injection valve 2, cylinder 1 is disconnected. (📖 p. 13)

### 3 ENGINE CONTROL TROUBLE CODE



#### Injection valve 2, cylinder 1 – check the resistance.

- $\Omega$  Measure the resistance between the specified points.  
Injection valves, cylinder 1 pin 1 – Injection valves, cylinder 1 pin 2

Injection valve	
Resistance at: 20 °C (68 °F)	11.4 ... 12.6 $\Omega$

- » If the specifications have not been met:
  - Change injection valve 2.
- » If the specifications have been met:
  - Check the next possible cause:  
Injection valve 2, cylinder 1 – the control wire has a short circuit to plus (terminal 30) (p. 66)

#### Injection valve 2, cylinder 1 – the control wire has a short circuit to plus (terminal 30)

##### Condition

The diagnostics tool is disconnected.

Engine control unit is disconnected. (p. 16)

The break out box is connected to the engine control unit wiring harness with adapter **00029095016**.

Injection valve 2, cylinder 1 is disconnected. (p. 13)

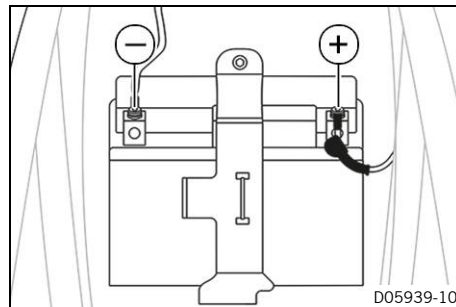
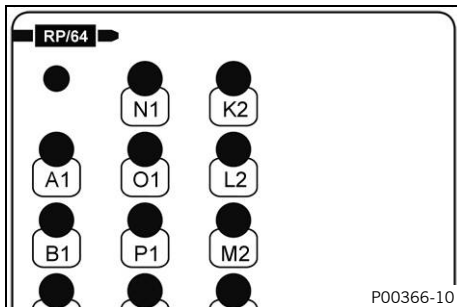

#### Injection valve 2, cylinder 1 – check the control wire for a short circuit to plus (terminal 30).

- **V** Measure the voltage between the specified points.  
Bob box connector **RP** pin **M3** – Measuring point **Ground (-)**

Voltage	< 0.1 V
---------	---------

- » If the specifications have not been met:
  - Check the cable from engine control unit connector **RP** (p. 157) pin **M3** to connector **GQ** (p. 155) pin **1** for a short circuit to plus (terminal 30).
- » If the specifications have been met:
  - Check the next possible cause:  
Injection valve 2, cylinder 1 – the control wire has a short circuit to ignition plus (terminal 15) (p. 66)

#### Injection valve 2, cylinder 1 – the control wire has a short circuit to ignition plus (terminal 15)

##### Condition

The diagnostics tool is disconnected.

Engine control unit is disconnected. (p. 16)

The break out box is connected to the engine control unit wiring harness with adapter **00029095016**.

Injection valve 2, cylinder 1 is disconnected. (p. 13)

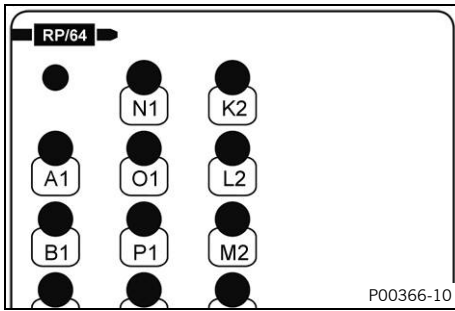

### Injection valve 2, cylinder 1 – check the control wire for a short circuit to ignition plus (terminal 15).

- Measure the resistance between the specified points.  
Bob box connector **RP** pin **M3** – Bob box connector **RP** pin **D4**

Resistance	$\infty \Omega$
------------	-----------------

- » If the specifications have not been met:
  - Check the cable from engine control unit connector **RP** (📖 p. 157) pin **M3** to connector **GQ** (📖 p. 155) pin **T** for a short circuit to ignition plus (terminal 15).
- » If the specifications have been met:
  - Check the next possible cause:  
Injection valve 2, cylinder 1 – the control wire has a short circuit to the sensor power supply (📖 p. 67)

### Injection valve 2, cylinder 1 – the control wire has a short circuit to the sensor power supply

#### Condition

The diagnostics tool is disconnected.  
 Engine control unit is disconnected. (📖 p. 16)  
 The break out box is connected to the engine control unit wiring harness with adapter **00029095016**.  
 Injection valve 2, cylinder 1 is disconnected. (📖 p. 13)

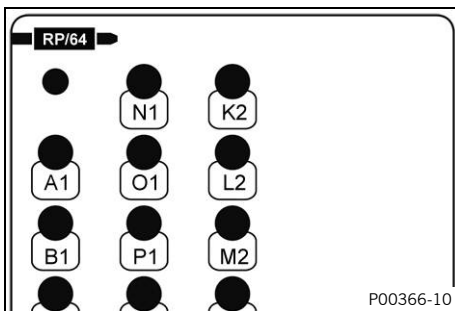

### Injection valve 2, cylinder 1 – check the control wire for a short circuit to the sensor power supply.

- Measure the resistance between the specified points.  
Bob box connector **RP** pin **M3** – Bob box connector **RP** pin **D3**

Resistance	$\infty \Omega$
------------	-----------------

- » If the specifications have not been met:
  - Check the cable from engine control unit connector **RP** (📖 p. 157) pin **M3** to connector **GQ** (📖 p. 155) pin **T** for a short circuit to the sensor power supply.
- » If the specifications have been met:
  - Contact customer service.

### 3 ENGINE CONTROL TROUBLE CODE

<b>Blink code for malfunction indicator lamp</b>	<b>Fi</b> 37 Malfunction indicator lamp flashes 3x long, 7x short
<b>Display on diagnostic tool</b>	P035100 "Ignition coil" "Circuit fault"
<b>Error level condition</b>	Ignition coil – circuit fault Time: ≥ 2.0 s
<b>Function check</b>	Checking the ignition coil (🔊 p. 68)
<b>Possible cause</b>	Ignition coil – the value is not plausible (🔊 p. 68)
	Ignition coil – control wire is faulty (🔊 p. 69)
	Ignition coil – the control wire has a short circuit to ground (terminal 31) (🔊 p. 69)
	Ignition coil – control wire has a short circuit to plus (terminal 30) (🔊 p. 70)
<b>Last measure if none of the documented causes leads to elimination of the fault</b>	– Contact customer service.

#### Checking the ignition coil

##### Condition

The diagnostics tool is connected and running.

- Execute **"Engine control unit" > "Actuator test" > "Ignition coil"**.

Spark plug	Operating noise
------------	-----------------

- » If the specified value is reached:
  - Clear the fault memory using the KTM diagnostics tool.
  - Take a test ride.
  - Read out the fault memory using the KTM diagnostics tool.
- » If the specification is not reached:
  - Check the next possible cause:  
Ignition coil – the value is not plausible (🔊 p. 68)
  - Check the next possible cause:  
Ignition coil – control wire is faulty (🔊 p. 69)
  - Check the next possible cause:  
Ignition coil – the control wire has a short circuit to ground (terminal 31) (🔊 p. 69)
  - Check the next possible cause:  
Ignition coil – control wire has a short circuit to plus (terminal 30) (🔊 p. 70)

#### Ignition coil – the value is not plausible

##### Condition

The diagnostics tool is disconnected.  
The ignition coil is disconnected. (🔊 p. 11)

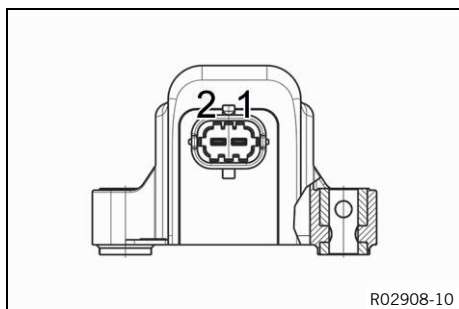

### Ignition coil - check the resistance.

- $\Omega$  Measure the resistance between the specified points.  
Ignition coil pin 1 (-) – Ignition coil pin 2 (+)

Ignition coil	
Primary winding resistance at: 20 °C (68 °F)	0.337 ... 0.412 $\Omega$

- » If the specifications have not been met:
  - Change the ignition coil.
- » If the specifications have been met:
  - Check the next possible cause:  
Ignition coil – control wire is faulty (🔧 p. 69)

### Ignition coil – control wire is faulty

#### Condition

The diagnostics tool is disconnected.

Engine control unit is disconnected. (🔧 p. 16)

The break out box is connected to the engine control unit wiring harness with adapter **00029095016**.

The ignition coil is disconnected. (🔧 p. 11)

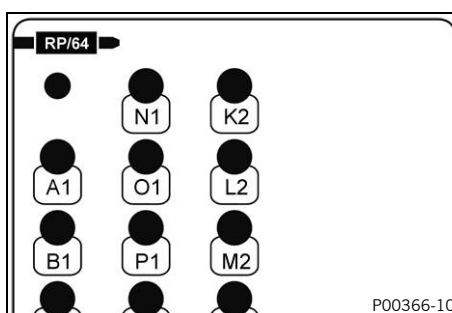
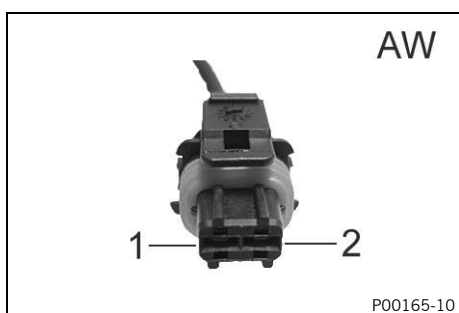

### Ignition coil - check the control wire.

- $\Omega$  Measure the resistance between the specified points.  
Ignition coil connector **AW** pin 1 – Bob box connector **RP** pin **Q3**

Resistance	0.6 $\Omega$
------------	--------------

- » If the specifications have not been met:
  - Check engine control unit connector **RP** (🔧 p. 157) pin **Q3** and connector **AW** (🔧 p. 153) pin 1.
  - Check the cable from engine control unit connector **RP** (🔧 p. 157) pin **Q3** to connector **AW** (🔧 p. 153) pin 1.
- » If the specifications have been met:
  - Check the next possible cause:  
Ignition coil – the control wire has a short circuit to ground (terminal 31) (🔧 p. 69)

### Ignition coil – the control wire has a short circuit to ground (terminal 31)

#### Condition

The diagnostics tool is disconnected.

Engine control unit is disconnected. (🔧 p. 16)

The break out box is connected to the engine control unit wiring harness with adapter **00029095016**.

The ignition coil is disconnected. (🔧 p. 11)

### 3 ENGINE CONTROL TROUBLE CODE

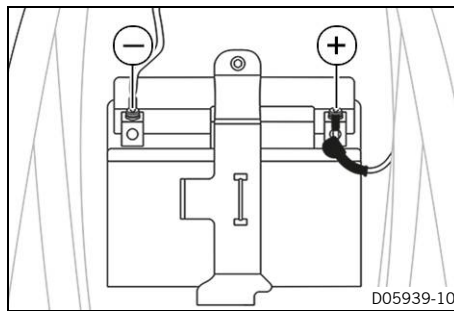
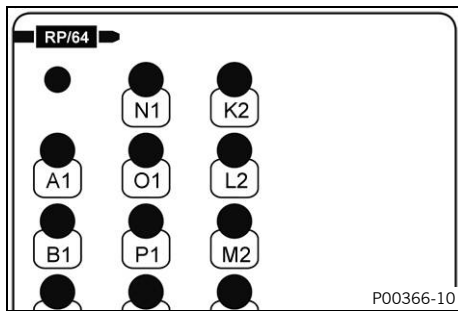

#### Ignition coil - check the control wire for a short circuit to ground (terminal 31).

- Measure the resistance between the specified points.  
Bob box connector **RP** pin **Q3** – Measuring point **Ground (-)**

Resistance	$\infty \Omega$
------------	-----------------

- » If the specifications have not been met:
  - Check the cable from engine control unit connector **RP** (p. 157) pin **Q3** to ignition coil connector **AW** (p. 153) pin **1** for a short circuit to ground (terminal 31).
- » If the specifications have been met:
  - Check the next possible cause:  
Ignition coil – control wire has a short circuit to plus (terminal 30) (p. 70)

#### Ignition coil – control wire has a short circuit to plus (terminal 30)

##### Condition

The diagnostics tool is disconnected.

Engine control unit is disconnected. (p. 16)

The break out box is connected to the engine control unit wiring harness with adapter **00029095016**.

The ignition coil is disconnected. (p. 11)

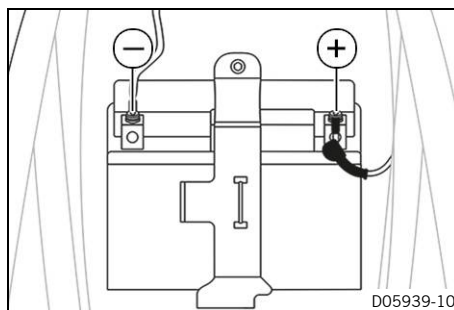
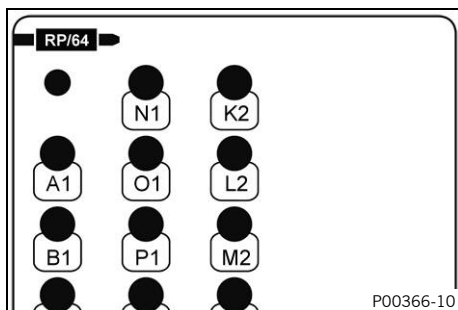

#### Ignition coil - check the control wire for a short circuit to plus (terminal 30).

- Measure the voltage between the specified points.  
Bob box connector **RP** pin **Q3** – Measuring point **Ground (-)**

Voltage	< 0.1 V
---------	---------

- » If the specifications have not been met:
  - Check the cable from engine control unit connector **RP** (p. 157) pin **Q3** to connector **AW** (p. 153) pin **1** for a short circuit to plus (terminal 30).
- » If the specifications have been met:
  - Contact customer service.

<b>Blink code for malfunction indicator lamp</b>	<b>Fi</b> 02 Malfunction indicator lamp flashes 2x short
<b>Display on diagnostic tool</b>	P037000 <b>"Crankshaft speed sensor"</b> <b>"Synchronization faulty"</b>
<b>Error level condition</b>	Crankshaft speed sensor – synchronization faulty Time: ≥ 1 s
<b>Function check</b>	Crankshaft speed sensor – checking the signal (📖 p. 71)
<b>Possible cause</b>	Crankshaft speed sensor – the value is not plausible (📖 p. 72)
	Crankshaft speed sensor – short circuit to ground (📖 p. 72)
	Crankshaft speed sensor – signal wires are faulty (📖 p. 73)
	Crankshaft speed sensor – the signal wires have a short circuit to ground (terminal 31) (📖 p. 73)
	Crankshaft speed sensor – the signal wires have a short circuit to sensor ground (📖 p. 74)
	Crankshaft speed sensor – the signal wires have a short circuit to plus (terminal 30) (📖 p. 74)
	Crankshaft speed sensor – the signal wires have a short circuit to ignition plus (terminal 15) (📖 p. 75)
	Crankshaft speed sensor – the signal wire has a short circuit to the sensor power supply (📖 p. 75)
<b>Last measure if none of the documented causes leads to elimination of the fault</b>	– Contact customer service.

## Crankshaft speed sensor – checking the signal

### Condition

The diagnostics tool is connected and running.

- Select **"Engine control unit" > "Measured values" > "Engine speed"**.
- Execute the start procedure.

<b>"Engine speed"</b>	Starter speed
-----------------------	---------------

- » If the specified value is reached:
  - Clear the fault memory using the KTM diagnostics tool.
  - Take a test ride.
  - Read out the fault memory using the KTM diagnostics tool.
- » If the specification is not reached:
  - Check the next possible cause:  
Crankshaft speed sensor – the value is not plausible (📖 p. 72)
  - Check the next possible cause:  
Crankshaft speed sensor – short circuit to ground (📖 p. 72)
  - Check the next possible cause:  
Crankshaft speed sensor – signal wires are faulty (📖 p. 73)
  - Check the next possible cause:  
Crankshaft speed sensor – the signal wires have a short circuit to ground (terminal 31) (📖 p. 73)
  - Check the next possible cause:  
Crankshaft speed sensor – the signal wires have a short circuit to sensor ground (📖 p. 74)
  - Check the next possible cause:  
Crankshaft speed sensor – the signal wires have a short circuit to plus (terminal 30) (📖 p. 74)
  - Check the next possible cause:

### 3 ENGINE CONTROL TROUBLE CODE

Crankshaft speed sensor – the signal wires have a short circuit to ignition plus (terminal 15) (📖 p. 75)

- Check the next possible cause:  
Crankshaft speed sensor – the signal wire has a short circuit to the sensor power supply (📖 p. 75)

#### Crankshaft speed sensor – the value is not plausible

##### Condition

Crankshaft speed sensor is disconnected. (📖 p. 10)

##### Crankshaft speed sensor – check the resistance.

- $\Omega$  Measure the resistance between the specified points.  
Crankshaft speed sensor connector **AT** pin 1 –  
Crankshaft speed sensor connector **AT** pin 2

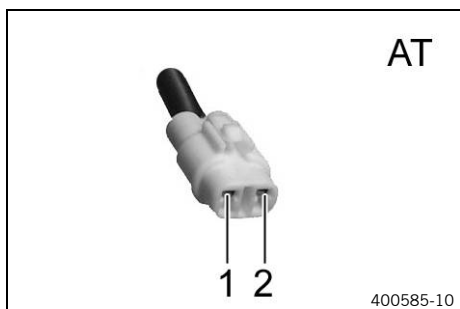

Crankshaft speed sensor	
Resistance at: 20 °C (68 °F)	108 ... 132 $\Omega$

- » If the specifications have not been met:
  - Change the crankshaft speed sensor.
- » If the specifications have been met:
  - Check the next possible cause:  
Crankshaft speed sensor – short circuit to ground (📖 p. 72)

#### Crankshaft speed sensor – short circuit to ground

##### Condition

The diagnostics tool is disconnected.

Crankshaft speed sensor is disconnected. (📖 p. 10)

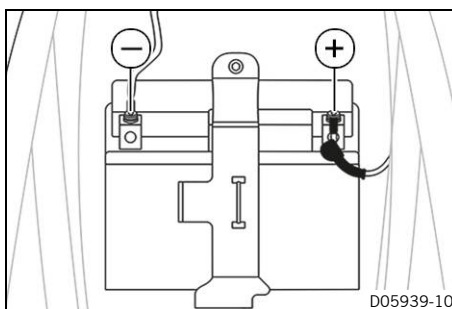
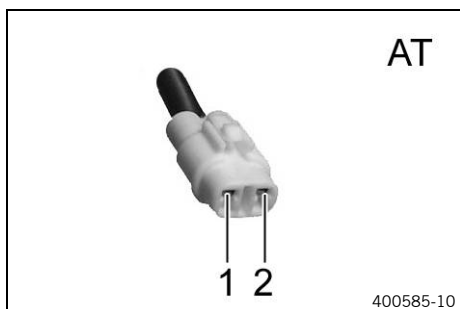

##### Crankshaft speed sensor – check the resistance.

- $\Omega$  Measure the resistance between the specified points.  
Crankshaft speed sensor connector **AT** pin 1 – Measuring point **Ground (-)**

Resistance	$\infty \Omega$
------------	-----------------

- » If the specifications have not been met:
  - Change the crankshaft speed sensor.
- » If the specifications have been met:
  - Check the next possible cause:  
Crankshaft speed sensor – signal wires are faulty (📖 p. 73)

## Crankshaft speed sensor – signal wires are faulty

### Condition

The diagnostics tool is disconnected.

Engine control unit is disconnected. (📖 p. 16)

The break out box is connected to the engine control unit wiring harness with adapter **00029095016**.

Crankshaft speed sensor is connected. (📖 p. 10)

### Crankshaft speed sensor – check the signal wire.

-  Measure the resistance between the specified points.  
Bob box connector **RP** pin **G4** – Bob box connector **RP** pin **H4**

Crankshaft speed sensor	
Resistance at: 20 °C (68 °F)	108 ... 132 Ω

- » If the specifications have not been met:
  - Check engine control unit connector **RP** (📖 p. 157) pin **G4** and pin **H4**.
  - Check connector **IF** (📖 p. 156) pin **2** and connector **IF** (📖 p. 156) pin **1**.
  - Check the cable from engine control unit connector **RP** (📖 p. 157) pin **H4** to connector **IF** (📖 p. 156) pin **2**.
  - Check the cable from engine control unit connector **RP** (📖 p. 157) pin **G4** to connector **IF** (📖 p. 156) pin **1**.
- » If the specifications have been met:
  - Check the next possible cause:  
Crankshaft speed sensor – the signal wires have a short circuit to ground (terminal 31) (📖 p. 73)

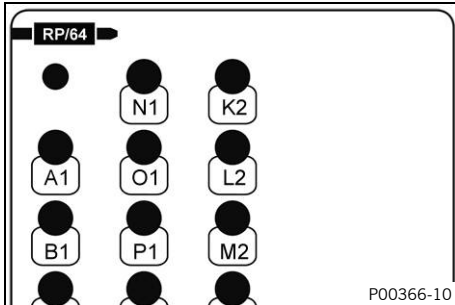

## Crankshaft speed sensor – the signal wires have a short circuit to ground (terminal 31)

### Condition

The diagnostics tool is disconnected.

Engine control unit is disconnected. (📖 p. 16)

The break out box is connected to the engine control unit wiring harness with adapter **00029095016**.

Crankshaft speed sensor is connected. (📖 p. 10)

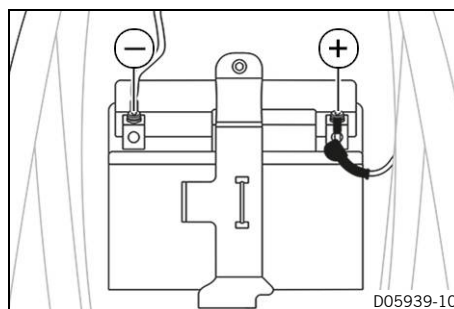
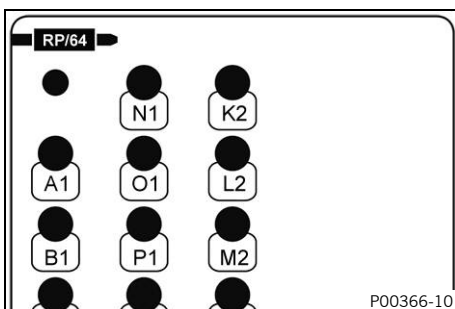

### Crankshaft speed sensor – check the signal wires for a short circuit to ground (terminal 31).

-  Measure the resistance between the specified points.  
Bob box connector **RP** pin **G4** – Measuring point **Ground (-)**

Resistance	∞ Ω
------------	-----

- » If the specifications have not been met:

### 3 ENGINE CONTROL TROUBLE CODE

- Check the cable from engine control unit connector **RP** (📖 p. 157) pin **G4** to connector **IF** (📖 p. 156) pin **1** for a short circuit to ground (terminal 31).
- Check the cable from engine control unit connector **RP** (📖 p. 157) pin **H4** to connector **IF** (📖 p. 156) pin **2** for a short circuit to ground (terminal 31).
- » If the specifications have been met:
  - Check the next possible cause:
    - Crankshaft speed sensor – the signal wires have a short circuit to sensor ground (📖 p. 74)

#### Crankshaft speed sensor – the signal wires have a short circuit to sensor ground

##### Condition

The diagnostics tool is disconnected.

Engine control unit is disconnected. (📖 p. 16)

The break out box is connected to the engine control unit wiring harness with adapter **00029095016**.

Crankshaft speed sensor is connected. (📖 p. 10)

##### Crankshaft speed sensor – check the signal wires for a short circuit to sensor ground.

-  Measure the resistance between the specified points.  
Bob box connector **RP** pin **G4** – Bob box connector **RP** pin **H4**

Resistance	$\infty \Omega$
------------	-----------------

- » If the specifications have not been met:
  - Check cable from engine control unit connector **RP** (📖 p. 157) pin **G4** to connector **IF** (📖 p. 156) pin **1** for a short circuit to sensor ground.
  - Check cable from engine control unit connector **RP** (📖 p. 157) pin **H4** to connector **IF** (📖 p. 156) pin **2** for a short circuit to sensor ground.
- » If the specifications have been met:
  - Check the next possible cause:
    - Crankshaft speed sensor – the signal wires have a short circuit to plus (terminal 30) (📖 p. 74)

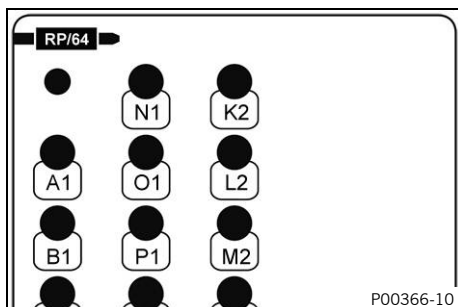

#### Crankshaft speed sensor – the signal wires have a short circuit to plus (terminal 30)

##### Condition

The diagnostics tool is disconnected.

Engine control unit is disconnected. (📖 p. 16)

The break out box is connected to the engine control unit wiring harness with adapter **00029095016**.

Crankshaft speed sensor is connected. (📖 p. 10)

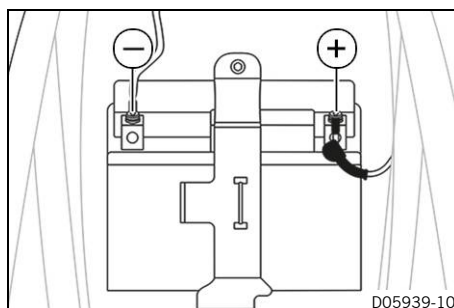
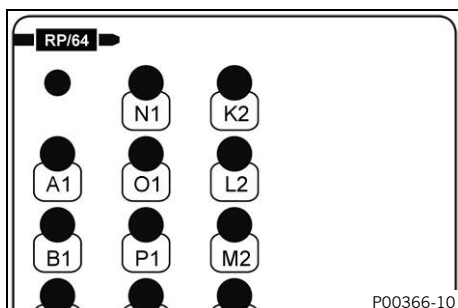

##### Crankshaft speed sensor – check the signal wires for a short circuit to plus (terminal 30).

-  Measure the voltage between the specified points.  
Bob box connector **RP** pin **G4** – Measuring point **Ground (-)**

Voltage	< 0.1 V
---------	---------

- » If the specifications have not been met:
  - Check the cable from engine control unit connector **RP** (📖 p. 157) pin **G4** to connector **IF** (📖 p. 156) pin **1** for a short circuit to plus (terminal 30).
  - Check the cable from engine control unit connector **RP** (📖 p. 157) pin **H4** to connector **IF** (📖 p. 156) pin **2** for a short circuit to plus (terminal 30).
- » If the specifications have been met:
  - Check the next possible cause:  
Crankshaft speed sensor – the signal wires have a short circuit to ignition plus (terminal 15) (📖 p. 75)

### Crankshaft speed sensor – the signal wires have a short circuit to ignition plus (terminal 15)

**Condition**

The diagnostics tool is disconnected.  
 Engine control unit is disconnected. (📖 p. 16)  
 The break out box is connected to the engine control unit wiring harness with adapter **00029095016**.  
 Crankshaft speed sensor is connected. (📖 p. 10)

**Crankshaft speed sensor – check the signal wire for a short circuit to ignition plus (terminal 15).**

- Measure the resistance between the specified points.  
Bob box connector **RP** pin **G4** – Bob box connector **RP** pin **D4**

Resistance	$\infty \Omega$
------------	-----------------

- » If the specifications have not been met:
  - Check the cable from engine control unit connector **RP** (📖 p. 157) pin **G4** to connector **IF** (📖 p. 156) pin **1** for a short circuit to ignition plus (terminal 15).
  - Check the cable from engine control unit connector **RP** (📖 p. 157) pin **H4** to connector **IF** (📖 p. 156) pin **2** for a short circuit to ignition plus (terminal 15).
- » If the specifications have been met:
  - Check the next possible cause:  
Crankshaft speed sensor – the signal wire has a short circuit to the sensor power supply (📖 p. 75)

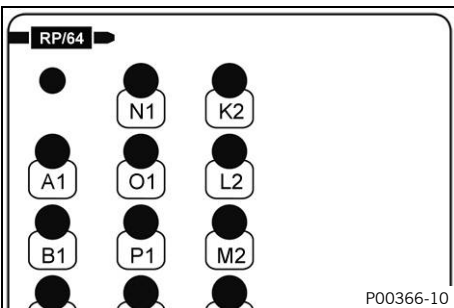

### Crankshaft speed sensor – the signal wire has a short circuit to the sensor power supply

**Condition**

The diagnostics tool is disconnected.  
 Engine control unit is disconnected. (📖 p. 16)  
 The break out box is connected to the engine control unit wiring harness with adapter **00029095016**.  
 Crankshaft speed sensor is connected. (📖 p. 10)

**Crankshaft speed sensor – check the signal wire for a short circuit to the sensor power supply.**

- Measure the resistance between the specified points.  
Bob box connector **RP** pin **G4** – Bob box connector **RP** pin **D3**

Resistance	$\infty \Omega$
------------	-----------------

- » If the specifications have not been met:

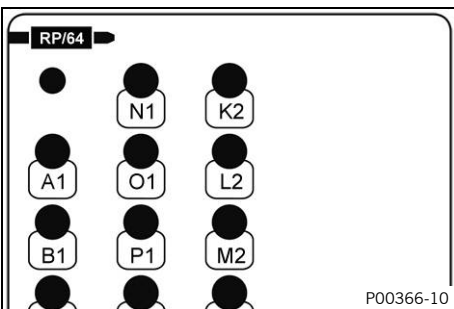

### 3 ENGINE CONTROL TROUBLE CODE

- Check the cable from engine control unit connector **RP** (p. 157) pin **G4** to connector **IF** (p. 156) pin **1** for a short circuit to the sensor power supply.
  - Check the cable from engine control unit connector **RP** (p. 157) pin **H4** to connector **IF** (p. 156) pin **2** for a short circuit to the sensor power supply.
- » If the specifications have been met:
- Contact customer service.

<b>Blink code for malfunction indicator lamp</b>	<b>Fi</b> 02 Malfunction indicator lamp flashes 2x short
<b>Display on diagnostic tool</b>	P037100 "Crankshaft speed sensor" "Signal not plausible"
<b>Error level condition</b>	Crankshaft position sensor - too many impulses Time: ≥ 0.1 s
<b>Function check</b>	Crankshaft speed sensor – checking the signal (  p. 77)
<b>Last measure if none of the documented causes leads to elimination of the fault</b>	– Contact customer service.

## Crankshaft speed sensor – checking the signal

### Condition

The diagnostics tool is connected and running.

- Select **"Engine control unit" > "Measured values" > "Engine speed"**.
- Execute the start procedure.

<b>"Engine speed"</b>	Starter speed
-----------------------	---------------

- » If the specified value is reached:
  - Clear the fault memory using the KTM diagnostics tool.
  - Take a test ride.
  - Read out the fault memory using the KTM diagnostics tool.
- » If the specification is not reached:
  - Check wires for damage.
  - If necessary, change wires.

### Last measure if none of the documented causes leads to elimination of the fault

- Contact customer service.

### 3 ENGINE CONTROL TROUBLE CODE

<b>Blink code for malfunction indicator lamp</b>	<b>Fi</b> 50 Malfunction indicator lamp flashes 5x long
<b>Display on diagnostic tool</b>	P047531 "Exhaust control actuator" "No signal"
<b>Error level condition</b>	Exhaust control actuator – no signal
<b>Possible cause</b>	Exhaust control actuator – the signal wire is faulty (📖 p. 78)
	Exhaust control actuator – the power supply is faulty (📖 p. 78)
<b>Last measure if none of the documented causes leads to elimination of the fault</b>	– Contact customer service.

#### Exhaust control actuator – the signal wire is faulty

##### Condition

The diagnostics tool is disconnected.

Engine control unit is disconnected. (📖 p. 16)

The break out box is connected to the engine control unit wiring harness with adapter **00029095016**.

Exhaust control actuator is disconnected. (📖 p. 17)

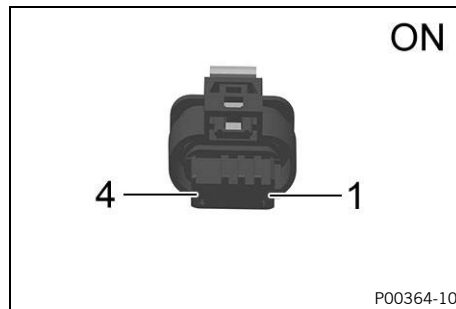
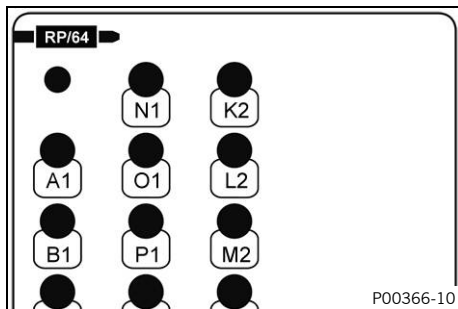

##### Exhaust control actuator – check the signal wire.

-  Measure the resistance between the specified points.  
Bob box connector **RP** pin **B1** – Exhaust control actuator **ON** pin **4**

Resistance	≤ 0.6 Ω
------------	---------

- » If the specifications have not been met:
  - Check engine control unit connector **RP** (📖 p. 157) pin **B1** and connector **ON** (📖 p. 157) pin **4**.
  - Check the cable from engine control unit connector **RP** (📖 p. 157) pin **B1** to connector **ON** (📖 p. 157) pin **4**.
- » If the specifications have been met:
  - Check the next possible cause:  
Exhaust control actuator – the power supply is faulty (📖 p. 78)

#### Exhaust control actuator – the power supply is faulty

##### Condition

The diagnostics tool is connected and running.

Engine control unit is connected. (📖 p. 16)

Exhaust control actuator is disconnected. (📖 p. 17)

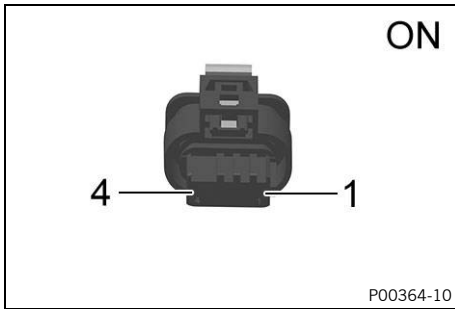

#### Exhaust control actuator – check the power supply.

- **V** Measure the voltage between the specified points.  
Exhaust control actuator **ON** pin 1 – Exhaust control actuator **ON** pin 3



#### Info

For the measurement, the measuring points must be subjected to a 12 V/21 W bulb.

The value must not deviate from the battery voltage "**VBAT**" by more than 1 V.

- » If the specifications have not been met:
  - Check connector **ON** (📖 p. 157) pin 1 and pin 3.
  - Check the cable from connector **ON** (📖 p. 157) pin 1 to the next node in the wiring harness.
  - Check the cable from connector **ON** (📖 p. 157) pin 3 to the next node in the wiring harness.
- » If the specifications have been met:
  - Contact customer service.

### 3 ENGINE CONTROL TROUBLE CODE

<b>Blink code for malfunction indicator lamp</b>	<b>Fi</b> 50 Malfunction indicator lamp flashes 5x long
<b>Display on diagnostic tool</b>	P04754B "Exhaust control actuator" "Temperature too high"
<b>Error level condition</b>	Exhaust control actuator – temperature too high
<b>Function check</b>	Checking the exhaust control actuator (📖 p. 80)
<b>Possible cause</b>	Exhaust control actuator has no function (📖 p. 80)
<b>Last measure if none of the documented causes leads to elimination of the fault</b>	– Contact customer service.

#### Checking the exhaust control actuator

##### Condition

The diagnostics tool is connected and running.

- Execute "**Engine control unit**" > "**Actuator test**" > "**Exhaust control actuator**".

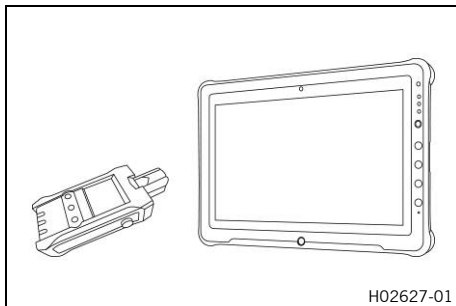

The exhaust control actuator audibly moves from the lower to upper stop position.

- » If the specified value is reached:
  - Clear the fault memory using the KTM diagnostics tool.
  - Take a test ride.
  - Read out the fault memory using the KTM diagnostics tool.
- » If the specification is not reached:
  - Check the next possible cause:  
Exhaust control actuator has no function (📖 p. 80)

#### Exhaust control actuator has no function

- Check the exhaust control actuator for mechanical damage.

Exhaust control actuator is not damaged.

- » If the specifications have not been met:
  - Change exhaust control actuator.
- » If the specifications have been met:
  - Contact customer service.

<b>Blink code for malfunction indicator lamp</b>	<b>Fi</b> 50 Malfunction indicator lamp flashes 5x long
<b>Display on diagnostic tool</b>	P047578 "Exhaust control actuator" "Incorrect setting"
<b>Error level condition</b>	Exhaust control actuator – incorrect setting
<b>Function check</b>	Calibrating the exhaust control actuator (🗨️ p. 81)
<b>Last measure if none of the documented causes leads to elimination of the fault</b>	– Change exhaust control actuator.

## Calibrating the exhaust control actuator

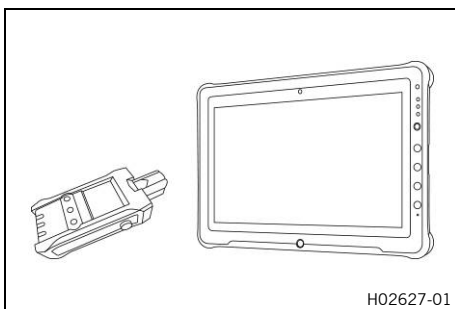

### Condition

The diagnostics tool is connected and running.

- Execute "**Engine control unit**" > "**Control unit functions**" > "**Teach in exhaust control actuator**".

### **i** Info

The instructions must be followed precisely.

- » If the specified value is reached:
  - Clear the fault memory using the KTM diagnostics tool.
  - Take a test ride.
  - Read out the fault memory using the KTM diagnostics tool.

### **Last measure if none of the documented causes leads to elimination of the fault**

- Change exhaust control actuator.

### 3 ENGINE CONTROL TROUBLE CODE

<b>Blink code for malfunction indicator lamp</b>	<b>Fi</b> 50 Malfunction indicator lamp flashes 5x long
<b>Display on diagnostic tool</b>	P047900 "Exhaust control actuator" "Setpoint value signal faulty"
<b>Error level condition</b>	Exhaust control actuator – setpoint value signal faulty
<b>Possible cause</b>	Exhaust control actuator – control wire is faulty (📖 p. 82) Exhaust control actuator – the power supply is faulty (📖 p. 82)
<b>Last measure if none of the documented causes leads to elimination of the fault</b>	– Contact customer service.

#### Exhaust control actuator – control wire is faulty

##### Condition

The diagnostics tool is disconnected.

Engine control unit is disconnected. (📖 p. 16)

The break out box is connected to the engine control unit wiring harness with adapter **00029095016**.

Exhaust control actuator is disconnected. (📖 p. 17)

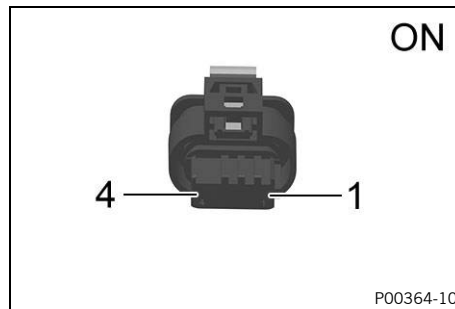
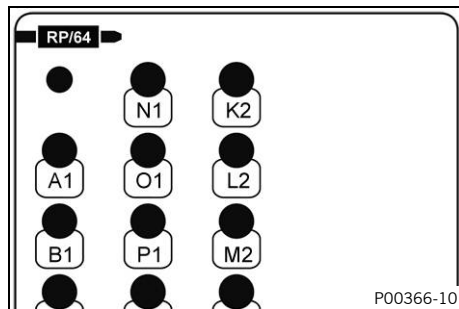

##### Exhaust control actuator – check the control wire.

-  Measure the resistance between the specified points.  
Bob box connector **RP** pin **P2** – Exhaust control actuator **ON** pin **2**

Resistance	$\leq 0.6 \Omega$
------------	-------------------

- » If the specifications have not been met:
  - Check engine control unit connector **RP** (📖 p. 157) pin **P2** and connector **ON** (📖 p. 157) pin **2**.
  - Check the cable from engine control unit connector **RP** (📖 p. 157) pin **P2** to connector **ON** (📖 p. 157) pin **2**.
- » If the specifications have been met:
  - Check the next possible cause:  
Exhaust control actuator – the power supply is faulty (📖 p. 82)

#### Exhaust control actuator – the power supply is faulty

##### Condition

The diagnostics tool is connected and running.

Engine control unit is connected. (📖 p. 16)

Exhaust control actuator is disconnected. (📖 p. 17)

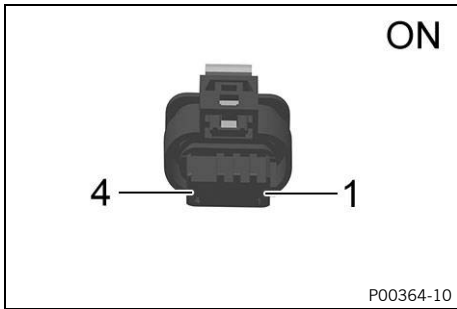

#### Exhaust control actuator – check the power supply.

- **V** Measure the voltage between the specified points.  
Exhaust control actuator **ON** pin 1 – Exhaust control actuator **ON** pin 3



#### Info

For the measurement, the measuring points must be subjected to a 12 V/21 W bulb.

The value must not deviate from the battery voltage "**VBAT**" by more than 1 V.

- » If the specifications have not been met:
  - Check connector **ON** (📖 p. 157) pin 1 and pin 3.
  - Check the cable from connector **ON** (📖 p. 157) pin 1 to the next node in the wiring harness.
  - Check the cable from connector **ON** (📖 p. 157) pin 3 to the next node in the wiring harness.
- » If the specifications have been met:
  - Contact customer service.

### 3 ENGINE CONTROL TROUBLE CODE

<b>Blink code for malfunction indicator lamp</b>	<b>Fi</b> 21 Malfunction indicator lamp flashes 2x long, 1x short
<b>Display on diagnostic tool</b>	P056200 "Battery voltage" "Input voltage too low"
<b>Error level condition</b>	Battery voltage - input voltage too low Engine control unit power supply: $\leq 9.9$ V Time: $\geq 1$ s
<b>Function check</b>	Checking the charging voltage (📖 p. 84)
<b>Possible cause</b>	Engine control unit – the power supply 1 is faulty (📖 p. 85)
	Engine control unit – the power supply 2 is faulty (📖 p. 85)
	Engine control unit – the power supply 3 is faulty (📖 p. 86)
	Engine control unit – the ground wire (I) is faulty (📖 p. 87)
	Engine control unit – the ground wire (II) is faulty (📖 p. 87)
<b>Last measure if none of the documented causes leads to elimination of the fault</b>	– Contact customer service.

#### Checking the charging voltage

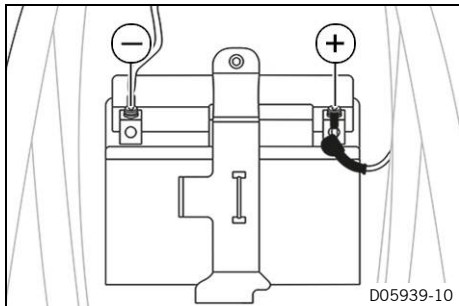

#### Condition

The 12-V battery must be fully functional and completely charged.

- Carry out start procedure.
- **V** Measure the voltage between the specified points.  
Measuring point **plus (+)** – Measuring point **Ground (-)**

Charging voltage	
5,000 rpm	13.5 ... 15.0 V

- » If the displayed value is less than the specified value:
  - Check alternator.
- » If the specification is not reached:
  - Check the next possible cause:  
Engine control unit – the power supply 1 is faulty (📖 p. 85)
  - Check the next possible cause:  
Engine control unit – the power supply 2 is faulty (📖 p. 85)
  - Check the next possible cause:  
Engine control unit – the power supply 3 is faulty (📖 p. 86)
  - Check the next possible cause:  
Engine control unit – the ground wire (I) is faulty (📖 p. 87)
  - Check the next possible cause:  
Engine control unit – the ground wire (II) is faulty (📖 p. 87)

## Engine control unit – the power supply 1 is faulty

### Condition

The ignition is on.

Engine control unit is disconnected. (📖 p. 16)

The break out box is connected to the engine control unit wiring harness with adapter **00029095016**.

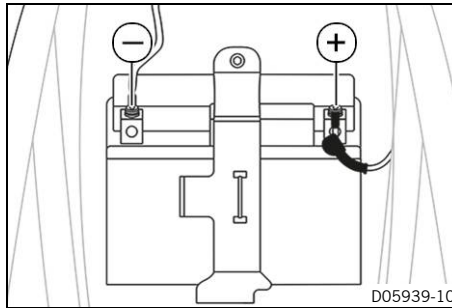
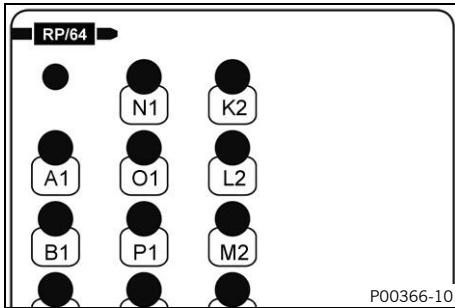

### Engine control unit – check the power supply 1.

- **V** Measure the voltage between the specified points.  
Bob box connector **RP** pin **Q4** – Measuring point **Ground (-)**



### Info

For the measurement, the measuring points must be subjected to a 12 V/21 W bulb.

The value must not deviate from the battery voltage "VBAT" by more than 1 V.

- » If the specifications have not been met:
  - Check the fuses.
  - Check engine control unit connector **RP** (📖 p. 157) pin **Q4**.
  - Check the wire from engine control unit connector **RP** (📖 p. 157) pin **Q4** according to the wiring diagram.
- » If the specifications have been met:
  - Check the next possible cause:  
Engine control unit – the power supply 2 is faulty (📖 p. 85)

## Engine control unit – the power supply 2 is faulty

### Condition

The ignition is on.

Engine control unit is disconnected. (📖 p. 16)

The break out box is connected to the engine control unit wiring harness with adapter **00029095016**.

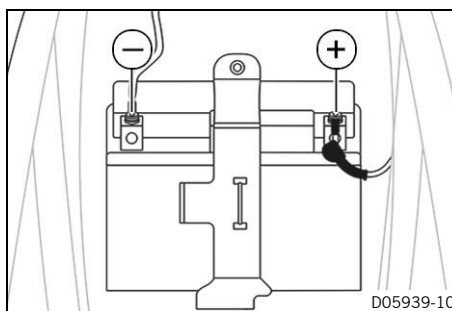
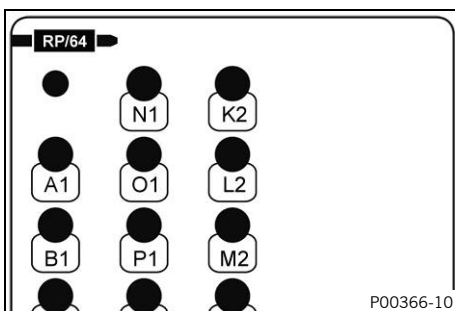

### Engine control unit – check the power supply 2.

- **V** Measure the voltage between the specified points.  
Bob box connector **RP** pin **C4** – Measuring point **Ground (-)**

**i Info**

For the measurement, the measuring points must be subjected to a 12 V/21 W bulb.

The value must not deviate from the battery voltage "VBAT" by more than 1 V.

- » If the specifications have not been met:
  - Check the fuses.
  - Check engine control unit connector **RP** (📖 p. 157) pin **C4**.
  - Check the wire from engine control unit connector **RP** (📖 p. 157) pin **C4** according to the wiring diagram.
- » If the specifications have been met:
  - Check the next possible cause:
    - Engine control unit – the power supply 3 is faulty (📖 p. 86)

## Engine control unit – the power supply 3 is faulty

**Condition**

The ignition is on.

Engine control unit is disconnected. (📖 p. 16)

The break out box is connected to the engine control unit wiring harness with adapter **00029095016**.

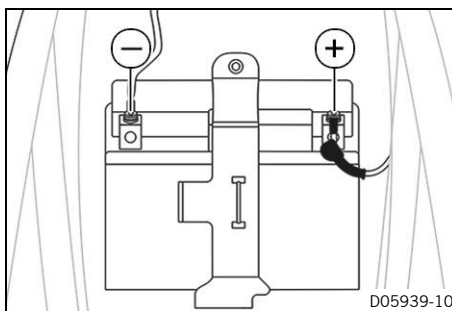
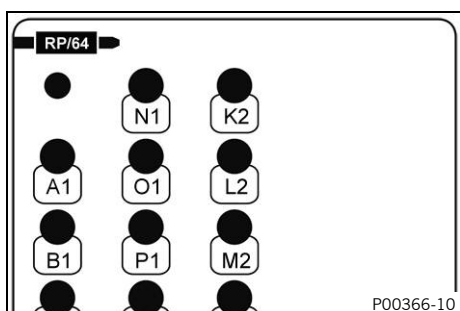

### Engine control unit – check the power supply 3.

- **V** Measure the voltage between the specified points.  
Bob box connector **RP** pin **D4** – Measuring point **Ground (-)**

**i Info**

For the measurement, the measuring points must be subjected to a 12 V/21 W bulb.

The value must not deviate from the battery voltage "VBAT" by more than 1 V.

- » If the specifications have not been met:
  - Check the fuse.
  - Check engine control unit connector **RP** (📖 p. 157) pin **D4**.
  - Check the wire from engine control unit connector **RP** (📖 p. 157) pin **D4** according to the wiring diagram.
- » If the specifications have been met:
  - Check the next possible cause:
    - Engine control unit – the ground wire (I) is faulty (📖 p. 87)

## Engine control unit – the ground wire (I) is faulty

### Condition

Engine control unit is disconnected. (📖 p. 16)

The break out box is connected to the engine control unit wiring harness with adapter **00029095016**.

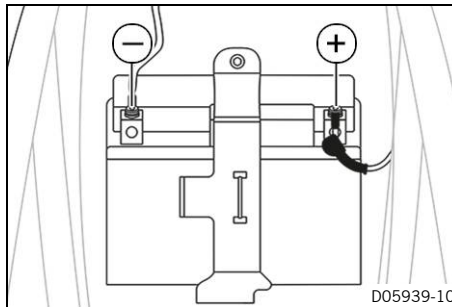
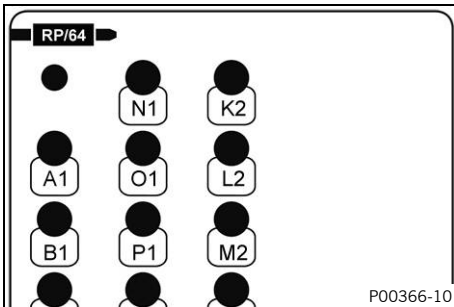

### Engine control unit – the ground wire (I) is faulty.

- **V** Measure the voltage between the specified points.  
Bob box connector **RP** pin **Q1** – Measuring point **plus (+)**



### Info

For the measurement, the measuring points must be subjected to a 12 V/21 W bulb.

The value must not deviate from the battery voltage "VBAT" by more than 1 V.

- » If the specifications have not been met:
  - Check engine control unit connector **RP** (📖 p. 157) pin **Q1**.
  - Check the cable from engine control unit connector **RP** (📖 p. 157) pin **Q1** to the next node in the wiring harness.
- » If the specifications have been met:
  - Check the next possible cause:  
Engine control unit – the ground wire (II) is faulty (📖 p. 87)

## Engine control unit – the ground wire (II) is faulty

### Condition

Engine control unit is disconnected. (📖 p. 16)

The break out box is connected to the engine control unit wiring harness with adapter **00029095016**.

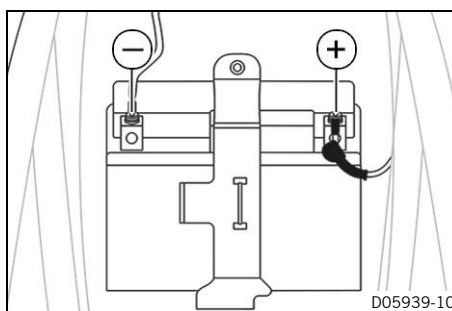
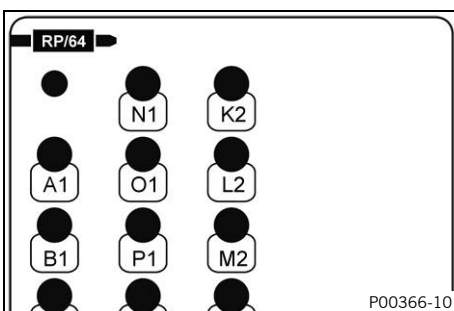

### Engine control unit – the ground wire (II) is faulty.

- **V** Measure the voltage between the specified points.  
Bob box connector **RP** pin **P1** – Measuring point **plus (+)**



### Info

For the measurement, the measuring points must be subjected to a 12 V/21 W bulb.

### 3 ENGINE CONTROL TROUBLE CODE

The value must not deviate from the battery voltage "**VBAT**" by more than 1 V.

- » If the specifications have not been met:
  - Check engine control unit connector **RP** (📖 p. 157) pin **P1**.
  - Check the cable from engine control unit connector **RP** (📖 p. 157) pin **P1** to the next node in the wiring harness.
- » If the specifications have been met:
  - Contact customer service.

<b>Blink code for malfunction indicator lamp</b>	<b>Fi</b> 21 Malfunction indicator lamp flashes 2x long, 1x short
<b>Display on diagnostic tool</b>	P056300 "Battery voltage" "Input voltage too high"
<b>Error level condition</b>	Battery voltage – input voltage too high Engine control unit power supply: $\geq 16.10$ V Time: $\geq 1$ s
<b>Function check</b>	Checking the charging voltage (📖 p. 89)
<b>Last measure if none of the documented causes leads to elimination of the fault</b>	– Contact customer service.

## Checking the charging voltage

### Condition

The 12-V battery must be fully functional and completely charged.

- Remove the seat.
- Start the motorcycle to check the function.
- **V** Measure the voltage between the specified points.  
Measuring point **plus (+)** – Measuring point **Ground (-)**

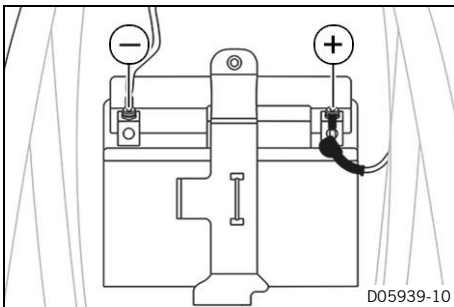

Charging voltage	
5,000 rpm	13.5 ... 15.0 V

- » If the displayed value is less than the specified value:
  - Check the plug-in connections from the alternator to the voltage regulator.
  - Check the plug-in connections from the voltage regulator to the wiring harness.
  - Check the stator of the ignition.
- » If the displayed value is greater than the specified value:
  - Change voltage regulator.

### Last measure if none of the documented causes leads to elimination of the fault

- Contact customer service.

### 3 ENGINE CONTROL TROUBLE CODE

<b>Blink code for malfunction indicator lamp</b>	<b>Fi</b> 53 Malfunction indicator lamp flashes 5x long, 3x short
<b>Display on diagnostic tool</b>	P064200 "Sensor voltage 1" "Short circuit to ground or open circuit"
<b>Error level condition</b>	Sensor voltage 1 – open circuit/short circuit to ground
<b>Possible cause</b>	Sensor voltage 1 has a short circuit to ground (terminal 31) (📖 p. 90)
	Sensor voltage 1 has a short circuit to sensor ground (📖 p. 90)
	Sensor voltage 1 malfunction (📖 p. 91)
<b>Last measure if none of the documented causes leads to elimination of the fault</b>	– Contact customer service.

#### Sensor voltage 1 has a short circuit to ground (terminal 31)

##### Condition

The diagnostics tool is disconnected.

Engine control unit is disconnected. (📖 p. 16)

The break out box is connected to the engine control unit wiring harness with adapter **00029095016**.

The tilt sensor is disconnected. (📖 p. 15)

Crankcase pressure sensor is disconnected. (📖 p. 12)

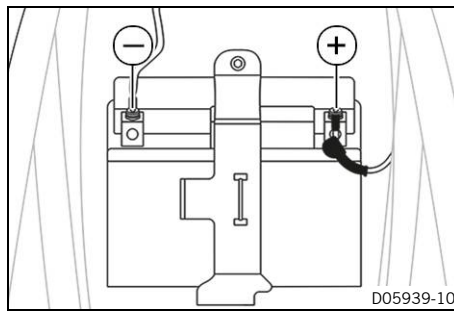
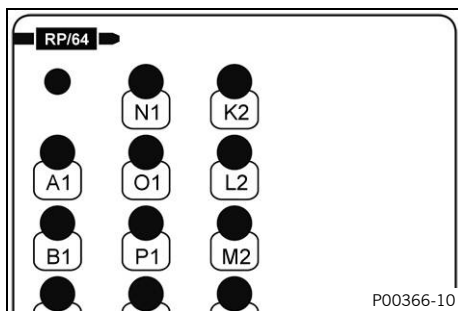

##### Checking sensor voltage 1 for a short circuit to ground (terminal 31).

- Measure the resistance between the specified points.  
Bob box connector **RP** pin **D3** – Measuring point **Ground (-)**

Resistance	$\infty \Omega$
------------	-----------------

- » If the specifications have not been met:
  - Check the cable of engine control unit connector **RP** (📖 p. 157) pin **D3** against the wiring diagram for a short circuit to ground (terminal 31).
- » If the specifications have been met:
  - Check the next possible cause:  
Sensor voltage 1 has a short circuit to sensor ground (📖 p. 90)

#### Sensor voltage 1 has a short circuit to sensor ground

##### Condition

The diagnostics tool is disconnected.

Engine control unit is disconnected. (📖 p. 16)

The break out box is connected to the engine control unit wiring harness with adapter **00029095016**.

The tilt sensor is disconnected. (📖 p. 15)

Crankcase pressure sensor is disconnected. (📖 p. 12)

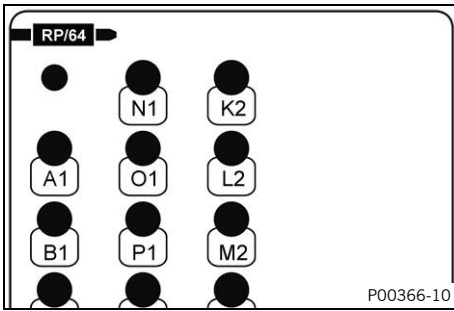

### Check sensor voltage 1 for a short circuit to sensor ground.

-  Measure the resistance between the specified points.  
Bob box connector **RP** pin **D3** – Bob box connector **RP** pin **C2**

Resistance	$\infty \Omega$
------------	-----------------

- » If the specifications have not been met:
  - Check the cable of engine control unit connector **RP** (p. 157) pin **D3** against the wiring diagram for a short circuit to sensor ground.
- » If the specifications have been met:
  - Check the next possible cause:  
Sensor voltage 1 malfunction (p. 91)

## Sensor voltage 1 malfunction

### Condition

The diagnostics tool is connected and running.

Engine control unit is connected. (p. 16)

The break-out box is connected to the engine control unit and the wiring harness with adapter **00029095016**.

### Sensor voltage 1 – check the voltage.

-  Measure the voltage between the specified points.  
Bob box connector **RP** pin **D3** – Bob box connector **RP** pin **C2**

Voltage	4.8 ... 5.2 V
---------	---------------

- » If the specifications have not been met:
  - Check the wire from engine control unit connector **RP** (p. 157) pin **D3** according to the wiring diagram.
  - Check the cable from connector **LU** (p. 156) pin **2** to engine control unit connector **RP** (p. 157) pin **C2**.
- » If the specifications have been met:
  - Contact customer service.

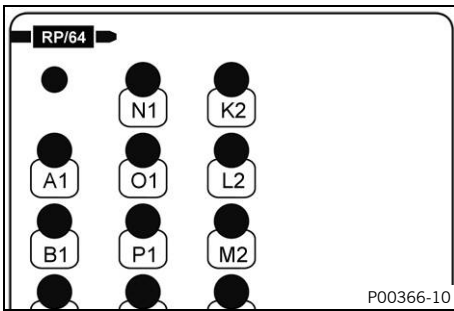

### 3 ENGINE CONTROL TROUBLE CODE

<b>Blink code for malfunction indicator lamp</b>	<b>Fi</b> 53 Malfunction indicator lamp flashes 5x long, 3x short
<b>Display on diagnostic tool</b>	P064300 "Sensor voltage 1" "Short circuit to plus"
<b>Error level condition</b>	Sensor voltage 1 – short circuit to plus
<b>Possible cause</b>	Sensor voltage 1 has a short circuit to plus (terminal 30) (📖 p. 92)
	Sensor voltage 1 has a short circuit to ignition plus (terminal 15) (📖 p. 92)
	Sensor voltage 1 malfunction (📖 p. 91)
<b>Last measure if none of the documented causes leads to elimination of the fault</b>	– Contact customer service.

#### Sensor voltage 1 has a short circuit to plus (terminal 30)

##### Condition

The diagnostics tool is disconnected.

Engine control unit is disconnected. (📖 p. 16)

The break out box is connected to the engine control unit wiring harness with adapter **00029095016**.

The tilt sensor is disconnected. (📖 p. 15)

Crankcase pressure sensor is disconnected. (📖 p. 12)

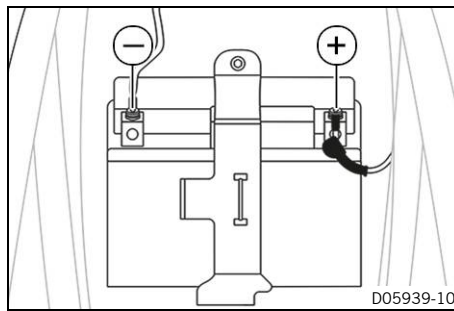
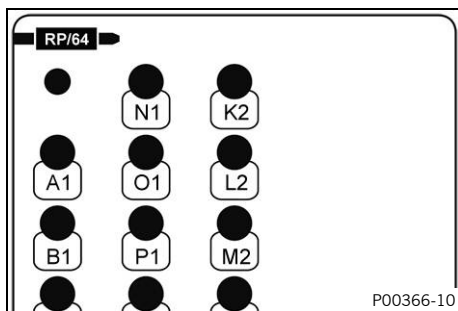

##### Check sensor voltage 1 for a short circuit to plus (terminal 30).

- **V** Measure the voltage between the specified points.  
Bob box connector **RP** pin **D3** – Measuring point **Ground (-)**

Voltage	< 0.1 V
---------	---------

- » If the specifications have not been met:
  - Check the cable of engine control unit connector **RP** (📖 p. 157) pin **D3** against the wiring diagram for a short circuit to plus (terminal 30).
- » If the specifications have been met:
  - Check the next possible cause:  
Sensor voltage 1 has a short circuit to ignition plus (terminal 15) (📖 p. 92)

#### Sensor voltage 1 has a short circuit to ignition plus (terminal 15)

##### Condition

The diagnostics tool is disconnected.

Engine control unit is disconnected. (📖 p. 16)

The break out box is connected to the engine control unit wiring harness with adapter **00029095016**.

The tilt sensor is disconnected. (📖 p. 15)

Crankcase pressure sensor is disconnected. (📖 p. 12)

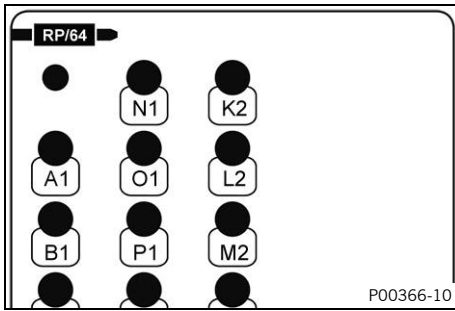

### Check sensor voltage 1 for a short circuit to ignition plus (terminal 15).

- Measure the resistance between the specified points.  
Bob box connector **RP** pin **D3** – Bob box connector **RP** pin **D4**

Resistance	$\infty \Omega$
------------	-----------------

- » If the specifications have not been met:
  - Check the cable of engine control unit connector **RP** (📖 p. 157) pin **D3** against the wiring diagram for a short circuit to ignition plus (terminal 15).
- » If the specifications have been met:
  - Check the next possible cause:  
Sensor voltage 1 malfunction (📖 p. 93)

## Sensor voltage 1 malfunction

### Condition

The diagnostics tool is connected and running.  
Engine control unit is connected. (📖 p. 16)  
The break-out box is connected to the engine control unit and the wiring harness with adapter **00029095016**.

### Sensor voltage 1 – check the voltage.

- Measure the voltage between the specified points.  
Bob box connector **RP** pin **D3** – Bob box connector **RP** pin **C2**

Voltage	4.8 ... 5.2 V
---------	---------------

- » If the specifications have not been met:
  - Check the wire from engine control unit connector **RP** (📖 p. 157) pin **D3** according to the wiring diagram.
  - Check the cable from connector **LU** (📖 p. 156) pin **2** to engine control unit connector **RP** (📖 p. 157) pin **C2**.
- » If the specifications have been met:
  - Contact customer service.

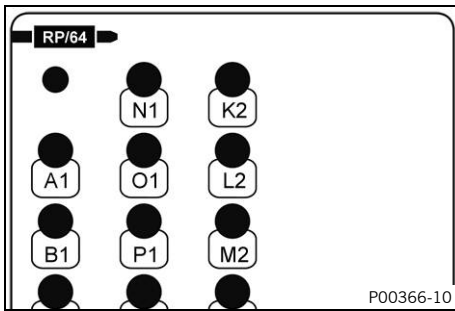

### 3 ENGINE CONTROL TROUBLE CODE

<b>Blink code for malfunction indicator lamp</b>	<b>Fi</b> 54 Malfunction indicator lamp flashes 5x long, 4x short
<b>Display on diagnostic tool</b>	P065200 "Sensor voltage 2" "Short circuit to ground or open circuit"
<b>Error level condition</b>	Sensor voltage 2 – open circuit/short circuit to ground
<b>Possible cause</b>	Sensor voltage 2 has a short circuit to ground (terminal 31) (📖 p. 94)
	Sensor voltage 2 has a short circuit to sensor ground (📖 p. 94)
	Sensor voltage 2 malfunction (📖 p. 95)
<b>Last measure if none of the documented causes leads to elimination of the fault</b>	– Contact customer service.

#### Sensor voltage 2 has a short circuit to ground (terminal 31)

##### Condition

The diagnostics tool is disconnected.

Engine control unit is disconnected. (📖 p. 16)

The break out box is connected to the engine control unit wiring harness with adapter **00029095016**.

Throttle valve position sensor circuit A is disconnected. (📖 p. 14)

Ambient air pressure sensor is disconnected. (📖 p. 15)

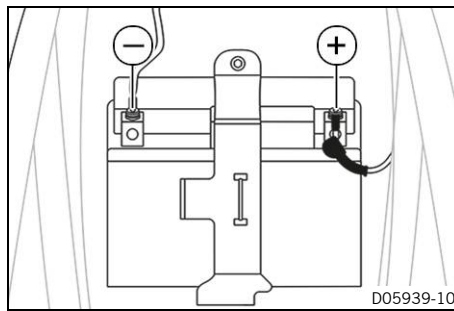
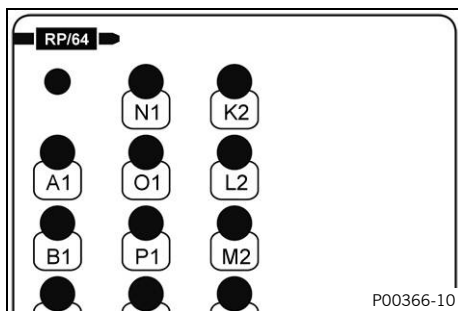

##### Checking sensor voltage 2 for a short circuit to ground (terminal 31).

-  Measure the resistance between the specified points.  
Bob box connector **RP** pin **D2** – Measuring point **Ground (-)**

Resistance	$\infty \Omega$
------------	-----------------

- » If the specifications have not been met:
  - Check the cable of engine control unit connector **RP** (📖 p. 157) pin **D2** against the wiring diagram for a short circuit to ground (terminal 31).
- » If the specifications have been met:
  - Check the next possible cause:  
Sensor voltage 2 has a short circuit to sensor ground (📖 p. 94)

#### Sensor voltage 2 has a short circuit to sensor ground

##### Condition

The diagnostics tool is disconnected.

Engine control unit is disconnected. (📖 p. 16)

The break out box is connected to the engine control unit wiring harness with adapter **00029095016**.

Throttle valve position sensor circuit A is disconnected. (📖 p. 14)

Ambient air pressure sensor is disconnected. (📖 p. 15)

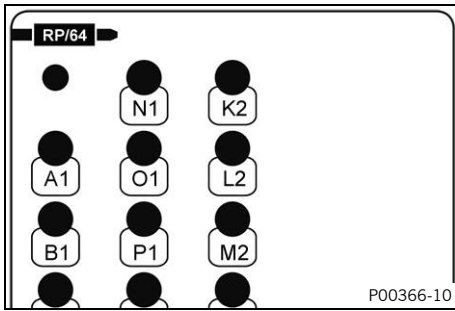

### Check sensor voltage 2 for a short circuit to sensor ground.

- Measure the resistance between the specified points.  
Bob box connector **RP** pin **D2** – Bob box connector **RP** pin **E2**

Resistance	$\infty \Omega$
------------	-----------------

- » If the specifications have not been met:
  - Check the cable of engine control unit connector **RP** (p. 157) pin **D2** against the wiring diagram for a short circuit to sensor ground.
- » If the specifications have been met:
  - Check the next possible cause:  
Sensor voltage 2 malfunction (p. 95)

## Sensor voltage 2 malfunction

### Condition

The diagnostics tool is connected and running.  
Engine control unit is connected. (p. 16)  
The break-out box is connected to the engine control unit and the wiring harness with adapter **00029095016**.

### Sensor voltage 2 – check the voltage.

- Measure the voltage between the specified points.  
Bob box connector **RP** pin **D2** – Bob box connector **RP** pin **E2**

Voltage	4.8 ... 5.2 V
---------	---------------

- » If the specifications have not been met:
  - Check the wire from engine control unit connector **RP** (p. 157) pin **D2** according to the wiring diagram.
  - Check the wire from engine control unit connector **RP** (p. 157) pin **E2** according to the wiring diagram.
- » If the specifications have been met:
  - Contact customer service.

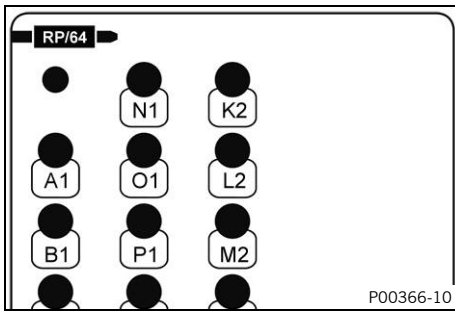

### 3 ENGINE CONTROL TROUBLE CODE

<b>Blink code for malfunction indicator lamp</b>	<b>Fi</b> 54 Malfunction indicator lamp flashes 5x long, 4x short
<b>Display on diagnostic tool</b>	P065300 "Sensor voltage 2" "Short circuit to plus"
<b>Error level condition</b>	Sensor voltage 2 – short circuit to plus
<b>Possible cause</b>	Sensor voltage 2 has a short circuit to plus (terminal 30) (📖 p. 96)
	Sensor voltage 2 has a short circuit to ignition plus (terminal 15) (📖 p. 96)
	Sensor voltage 2 malfunction (📖 p. 95)
<b>Last measure if none of the documented causes leads to elimination of the fault</b>	– Contact customer service.

#### Sensor voltage 2 has a short circuit to plus (terminal 30)

##### Condition

The diagnostics tool is disconnected.

Engine control unit is disconnected. (📖 p. 16)

The break out box is connected to the engine control unit wiring harness with adapter **00029095016**.

Throttle valve position sensor circuit A is disconnected. (📖 p. 14)

Ambient air pressure sensor is disconnected. (📖 p. 15)

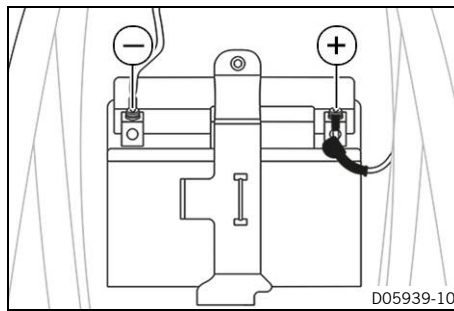
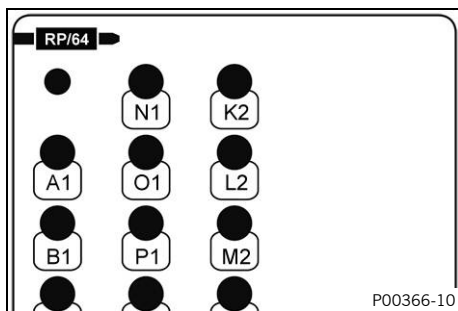

##### Check sensor voltage 2 for a short circuit to plus (terminal 30).

- **V** Measure the voltage between the specified points.  
Bob box connector **RP** pin **D2** – Measuring point **Ground (-)**

Voltage	< 0.1 V
---------	---------

- » If the specifications have not been met:
  - Check the cable of engine control unit connector **RP** (📖 p. 157) pin **D2** against the wiring diagram for a short circuit to plus (terminal 30).
- » If the specifications have been met:
  - Check the next possible cause:  
Sensor voltage 2 has a short circuit to ignition plus (terminal 15) (📖 p. 96)

#### Sensor voltage 2 has a short circuit to ignition plus (terminal 15)

##### Condition

The diagnostics tool is disconnected.

Engine control unit is disconnected. (📖 p. 16)

The break out box is connected to the engine control unit wiring harness with adapter **00029095016**.

Throttle valve position sensor circuit A is disconnected. (📖 p. 14)

Ambient air pressure sensor is disconnected. (📖 p. 15)

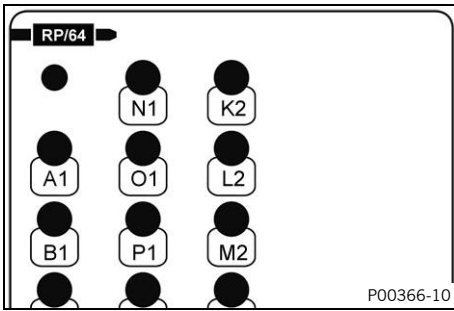

### Check sensor voltage 2 for a short circuit to ignition plus (terminal 15).

-  Measure the resistance between the specified points.  
Bob box connector **RP** pin **D2** – Bob box connector **RP** pin **D4**

Resistance	$\infty \Omega$
------------	-----------------

- » If the specifications have not been met:
  - Check the cable of engine control unit connector **RP** (p. 157) pin **D2** against the wiring diagram for a short circuit to ignition plus (terminal 15).
- » If the specifications have been met:
  - Check the next possible cause:  
Sensor voltage 2 malfunction (p. 97)

## Sensor voltage 2 malfunction

### Condition

The diagnostics tool is connected and running.

Engine control unit is connected. (p. 16)

The break-out box is connected to the engine control unit and the wiring harness with adapter **00029095016**.

### Sensor voltage 2 – check the voltage.

-  Measure the voltage between the specified points.  
Bob box connector **RP** pin **D2** – Bob box connector **RP** pin **E2**

Voltage	4.8 ... 5.2 V
---------	---------------

- » If the specifications have not been met:
  - Check the wire from engine control unit connector **RP** (p. 157) pin **D2** according to the wiring diagram.
  - Check the wire from engine control unit connector **RP** (p. 157) pin **E2** according to the wiring diagram.
- » If the specifications have been met:
  - Contact customer service.

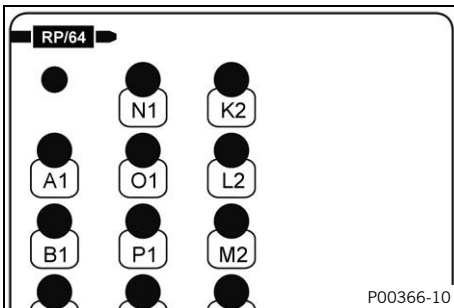

<b>Blink code for malfunction indicator lamp</b>	<b>Fi</b> 09 Malfunction indicator lamp flashes 9x short
<b>Display on diagnostic tool</b>	P110711 "Ambient air pressure sensor" "Short circuit to ground"
<b>Error level condition</b>	Ambient air pressure sensor voltage: $\leq 0.4$ V Time: $\geq 1$ s
<b>Function check</b>	Ambient air pressure sensor – checking the voltage (📖 p. 98)
<b>Possible cause</b>	Ambient air pressure sensor – the power supply is faulty (📖 p. 99)
	Ambient air pressure sensor – the signal wire has a short circuit to ground (terminal 31) (📖 p. 99)
	Ambient air pressure sensor – the signal wire has a short circuit to sensor ground (📖 p. 100)
<b>Last measure if none of the documented causes leads to elimination of the fault</b>	– Contact customer service.

## Ambient air pressure sensor – checking the voltage

### Condition

The diagnostics tool is connected and running.

Engine control unit is connected. (📖 p. 16)

The break out box is connected to the engine control unit wiring harness with adapter **00029095016**.

Ambient air pressure sensor is connected. (📖 p. 15)

- Select "**Engine control unit**" > "**Measured values**" > "**Ambient air pressure**".

### Ambient air pressure sensor – check the voltage.

- **V** Measure the voltage between the specified points.  
Bob box connector **RP** pin **E2** – Bob box connector **RP** pin **G2**

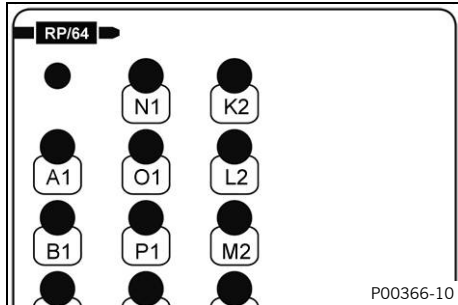

Ambient air pressure sensor voltage	
at: 133 mbar (1.93 psi)	1 V
at: 957 mbar (13.88 psi)	2.3 V
at: 2,500 mbar (36.26 psi)	4.75 V

- » If the displayed value is equal to the setpoint value:
  - Clear the fault memory using the KTM diagnostics tool.
  - Take a test ride.
  - Read out the fault memory using the KTM diagnostics tool.
- » If the displayed value is below the setpoint value:
  - Check the next possible cause:  
Ambient air pressure sensor – the power supply is faulty (📖 p. 99)
  - Check the next possible cause:  
Ambient air pressure sensor – the signal wire has a short circuit to ground (terminal 31) (📖 p. 99)
  - Check the next possible cause:  
Ambient air pressure sensor – the signal wire has a short circuit to sensor ground (📖 p. 100)

## Ambient air pressure sensor – the power supply is faulty

### Condition

The diagnostics tool is connected and running.

Engine control unit is connected. (📖 p. 16)

Ambient air pressure sensor is disconnected. (📖 p. 15)

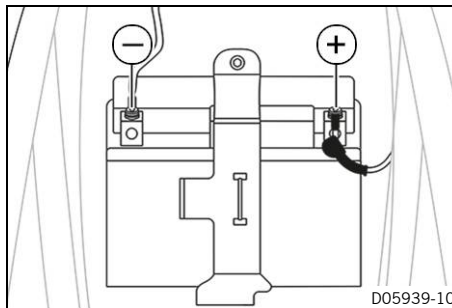
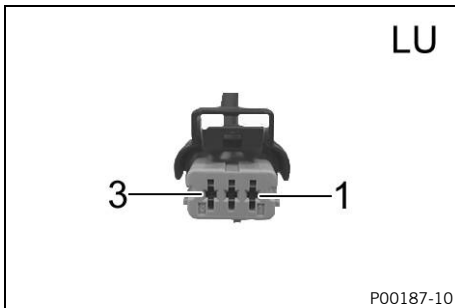

### Ambient air pressure sensor – check the power supply.

- **V** Measure the voltage between the specified points.  
Ambient air pressure sensor connector **LU** pin **1** – Measuring point **Ground (-)**



### Info

For the measurement, the measuring points must be subjected to a 12 V/21 W bulb.

Voltage	4.9 ... 5.1 V
---------	---------------

- » If the specifications have not been met:
  - Check connector **LU** (📖 p. 156) pin **1** and pin **2**.
  - Check the cable from connector **LU** (📖 p. 156) pin **1** to the next node in the wiring harness.
  - Check the cable from connector **LU** (📖 p. 156) pin **2** to the next node in the wiring harness.
- » If the specifications have been met:
  - Check the next possible cause:  
Ambient air pressure sensor – the signal wire has a short circuit to ground (terminal 31) (📖 p. 99)

## Ambient air pressure sensor – the signal wire has a short circuit to ground (terminal 31)

### Condition

The diagnostics tool is disconnected.

Engine control unit is disconnected. (📖 p. 16)

Ambient air pressure sensor is disconnected. (📖 p. 15)

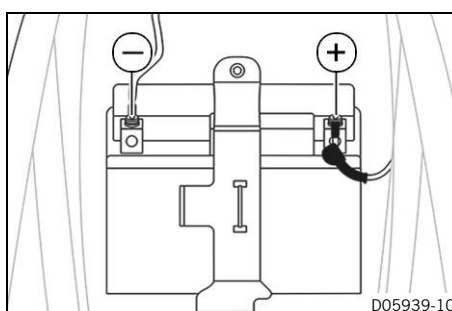
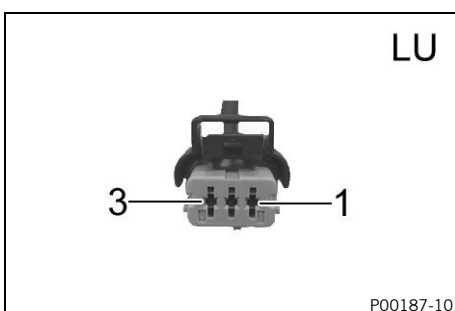

### Ambient air pressure sensor – check the signal wire for a short circuit to ground (terminal 31).

- **Ω** Measure the resistance between the specified points.  
Ambient air pressure sensor connector **LU** pin **3** – Measuring point **Ground (-)**

Resistance	$\infty \Omega$
------------	-----------------

## 3 ENGINE CONTROL TROUBLE CODE

- » If the specifications have not been met:
  - Check the cable of connector **LU** (📖 p. 156) pin **3** to engine control unit connector **RP** (📖 p. 157) pin **G2** for a short circuit to ground (terminal 31).
- » If the specifications have been met:
  - Check the next possible cause:  
Ambient air pressure sensor – the signal wire has a short circuit to sensor ground (📖 p. 100)

### Ambient air pressure sensor – the signal wire has a short circuit to sensor ground

#### Condition

The diagnostics tool is disconnected.

Engine control unit is disconnected. (📖 p. 16)

Ambient air pressure sensor is disconnected. (📖 p. 15)

#### Ambient air pressure sensor – check the signal wire for a short circuit to sensor ground.

- $\Omega$  Measure the resistance between the specified points.
  - Ambient air pressure sensor connector **LU** pin **3** –
  - Ambient air pressure sensor connector **LU** pin **2**

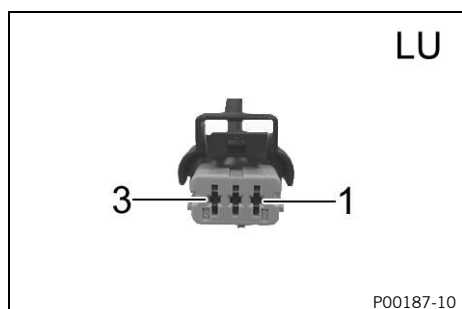

Resistance	$\infty \Omega$
------------	-----------------

- » If the specifications have not been met:
  - Check the cable from connector **LU** (📖 p. 156) pin **3** to engine control unit connector **RP** (📖 p. 157) pin **G2** for a short circuit to sensor ground.
- » If the specifications have been met:
  - Contact customer service.

<b>Blink code for malfunction indicator lamp</b>	<b>Fi</b> 09 Malfunction indicator lamp flashes 9x short
<b>Display on diagnostic tool</b>	P110812 "Ambient air pressure sensor" "Open/short circuit to plus"
<b>Error level condition</b>	Ambient air pressure sensor voltage: $\geq 4.6$ V Time: $\geq 0.1$ s
<b>Function check</b>	Ambient air pressure sensor – checking the voltage (📖 p. 101)
<b>Possible cause</b>	Ambient air pressure sensor – the signal wire is faulty (📖 p. 102)
	Ambient air pressure sensor – the ground wire is faulty (📖 p. 102)
	Ambient air pressure sensor – the signal wire has a short circuit to plus (terminal 30) (📖 p. 103)
	Ambient air pressure sensor – the signal wire has a short circuit to ignition plus (terminal 15) (📖 p. 104)
	Ambient air pressure sensor – the signal wire has a short circuit to the sensor power supply (📖 p. 104)
<b>Last measure if none of the documented causes leads to elimination of the fault</b>	– Contact customer service.

## Ambient air pressure sensor – checking the voltage

### Condition

- The diagnostics tool is connected and running.
- Engine control unit is connected. (📖 p. 16)
- The break out box is connected to the engine control unit wiring harness with adapter **00029095016**.
- Ambient air pressure sensor is connected. (📖 p. 15)
- Select **"Engine control unit" > "Measured values" > "Ambient air pressure"**.

### Ambient air pressure sensor – check the voltage.

- **V** Measure the voltage between the specified points.  
Bob box connector **RP** pin **E2** – Bob box connector **RP** pin **G2**

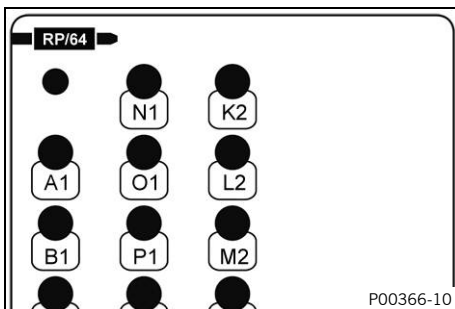

Ambient air pressure sensor voltage	
at: 133 mbar (1.93 psi)	1 V
at: 957 mbar (13.88 psi)	2.3 V
at: 2,500 mbar (36.26 psi)	4.75 V

- » If the displayed value is equal to the setpoint value:
  - Clear the fault memory using the KTM diagnostics tool.
  - Take a test ride.
  - Read out the fault memory using the KTM diagnostics tool.
- » If the displayed value is above the setpoint value:
  - Check the next possible cause:  
Ambient air pressure sensor – the signal wire is faulty (📖 p. 102)
  - Check the next possible cause:  
Ambient air pressure sensor – the ground wire is faulty (📖 p. 102)

### 3 ENGINE CONTROL TROUBLE CODE

- Check the next possible cause:  
Ambient air pressure sensor – the signal wire has a short circuit to plus (terminal 30) (📖 p. 103)
- Check the next possible cause:  
Ambient air pressure sensor – the signal wire has a short circuit to ignition plus (terminal 15) (📖 p. 104)
- Check the next possible cause:  
Ambient air pressure sensor – the signal wire has a short circuit to the sensor power supply (📖 p. 104)

#### Ambient air pressure sensor – the signal wire is faulty

##### Condition

The diagnostics tool is disconnected.

Engine control unit is disconnected. (📖 p. 16)

The break out box is connected to the engine control unit wiring harness with adapter **00029095016**.

Ambient air pressure sensor is disconnected. (📖 p. 15)

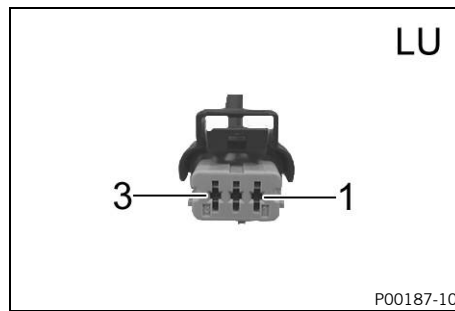
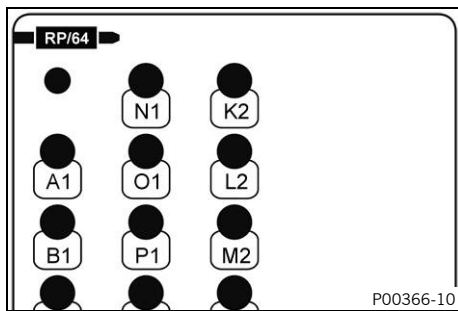

##### Ambient air pressure sensor – check the signal wire.

-  Measure the resistance between the specified points.  
Bob box connector **RP** pin **G2** – Ambient air pressure sensor connector **LU** pin **3**

Resistance	$\leq 0.6 \Omega$
------------	-------------------

- » If the specifications have not been met:
  - Check engine control unit connector **RP** (📖 p. 157) pin **G2** and connector **LU** (📖 p. 156) pin **3**.
  - Check the cable from engine control unit connector **RP** (📖 p. 157) pin **G2** to connector **LU** (📖 p. 156) pin **3**.
- » If the specifications have been met:
  - Check the next possible cause:  
Ambient air pressure sensor – the ground wire is faulty (📖 p. 102)

#### Ambient air pressure sensor – the ground wire is faulty

##### Condition

The diagnostics tool is disconnected.

Engine control unit is disconnected. (📖 p. 16)

The break out box is connected to the engine control unit wiring harness with adapter **00029095016**.

Ambient air pressure sensor is disconnected. (📖 p. 15)

Throttle valve position sensor circuit A is disconnected. (📖 p. 14)

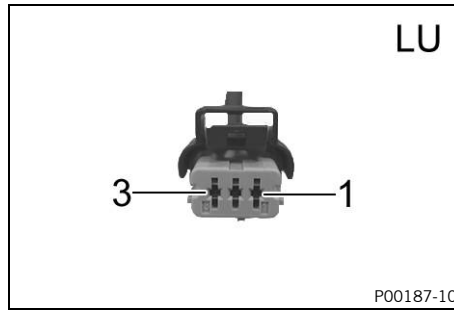
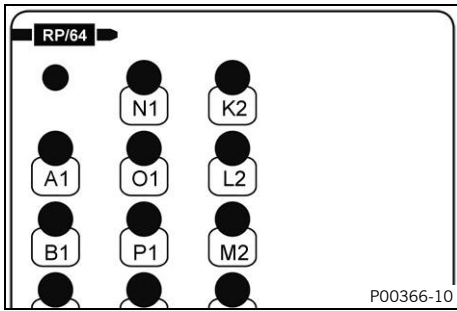

### Ambient air pressure sensor – check the ground wire.

- Measure the resistance between the specified points.  
Bob box connector **RP** pin **E2** – Ambient air pressure sensor connector **LU** pin **2**

Resistance	$\leq 0.6 \Omega$
------------	-------------------

- » If the specifications have not been met:
  - Check engine control unit connector **RP** (p. 157) pin **E2** and connector **LU** (p. 156) pin **2**.
  - Check the cable from engine control unit connector **RP** (p. 157) pin **E2** to connector **LU** (p. 156) pin **2**.
- » If the specifications have been met:
  - Check the next possible cause:  
Ambient air pressure sensor – the signal wire has a short circuit to plus (terminal 30) (p. 103)

### Ambient air pressure sensor – the signal wire has a short circuit to plus (terminal 30)

#### Condition

The diagnostics tool is disconnected.

Engine control unit is disconnected. (p. 16)

The break out box is connected to the engine control unit wiring harness with adapter **00029095016**.

Ambient air pressure sensor is disconnected. (p. 15)

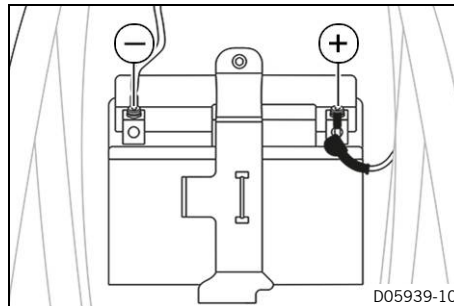
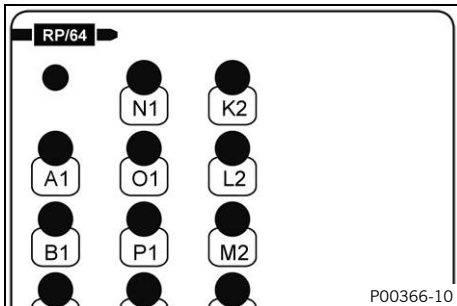

### Ambient air pressure sensor – check the signal wire for a short circuit to plus (terminal 30).

- Measure the voltage between the specified points.  
Bob box connector **RP** pin **G2** – Measuring point **Ground (-)**

Voltage	$< 0.1 \text{ V}$
---------	-------------------

- » If the specifications have not been met:
  - Check the cable from engine control unit connector **RP** (p. 157) pin **G2** to connector **LU** (p. 156) pin **3** for a short circuit to plus (terminal 30).
- » If the specifications have been met:
  - Check the next possible cause:  
Ambient air pressure sensor – the signal wire has a short circuit to ignition plus (terminal 15) (p. 104)

## Ambient air pressure sensor – the signal wire has a short circuit to ignition plus (terminal 15)

### Condition

The diagnostics tool is disconnected.

Engine control unit is disconnected. (📖 p. 16)

The break out box is connected to the engine control unit wiring harness with adapter **00029095016**.

Ambient air pressure sensor is disconnected. (📖 p. 15)

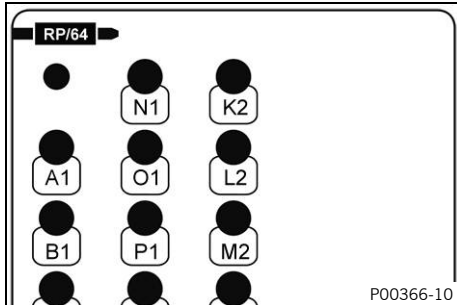

### Ambient air pressure sensor – check the signal wire for a short circuit to ignition plus (terminal 15).

- Measure the resistance between the specified points.  
Bob box connector **RP** pin **G2** – Bob box connector **RP** pin **D4**

Resistance	$\infty \Omega$
------------	-----------------

- » If the specifications have not been met:
  - Check the cable from engine control unit connector **RP** (📖 p. 157) pin **G2** to connector **LU** (📖 p. 156) pin **3** for a short circuit to ignition plus (terminal 15).
- » If the specifications have been met:
  - Check the next possible cause:  
Ambient air pressure sensor – the signal wire has a short circuit to the sensor power supply (📖 p. 104)

## Ambient air pressure sensor – the signal wire has a short circuit to the sensor power supply

### Condition

The diagnostics tool is disconnected.

Engine control unit is disconnected. (📖 p. 16)

The break out box is connected to the engine control unit wiring harness with adapter **00029095016**.

Ambient air pressure sensor is disconnected. (📖 p. 15)

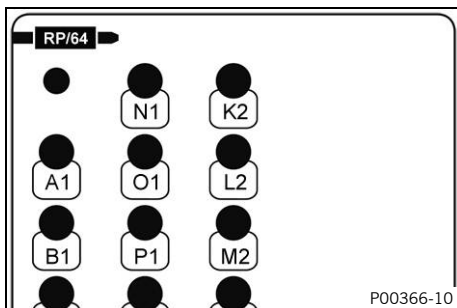

### Ambient air pressure sensor – check the signal wire for a short circuit to the sensor power supply.

- Measure the resistance between the specified points.  
Bob box connector **RP** pin **G2** – Bob box connector **RP** pin **D2**

Resistance	$\infty \Omega$
------------	-----------------

- » If the specifications have not been met:
  - Check the cable from engine control unit connector **RP** (📖 p. 157) pin **G2** to connector **LU** (📖 p. 156) pin **3** for a short circuit to the sensor power supply.
- » If the specifications have been met:
  - Contact customer service.

<b>Blink code for malfunction indicator lamp</b>	<b>Fi</b> 50 Malfunction indicator lamp flashes 5x long
<b>Display on diagnostic tool</b>	P140211 "Exhaust control actuator" "Input signal too low"
<b>Error level condition</b>	Exhaust control actuator – input signal too low
<b>Possible cause</b>	Exhaust control actuator – the control wire has a short circuit to ground (terminal 31) (📖 p. 105)
	Fuel pump – the control wire has a short circuit to sensor ground (📖 p. 105)
<b>Last measure if none of the documented causes leads to elimination of the fault</b>	– Contact customer service.

### Exhaust control actuator – the control wire has a short circuit to ground (terminal 31)

**Condition**

The diagnostics tool is disconnected.

Engine control unit is disconnected. (📖 p. 16)

The break out box is connected to the engine control unit wiring harness with adapter **00029095016**.

Exhaust control actuator is disconnected. (📖 p. 17)

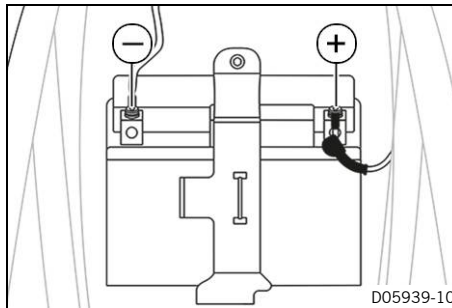
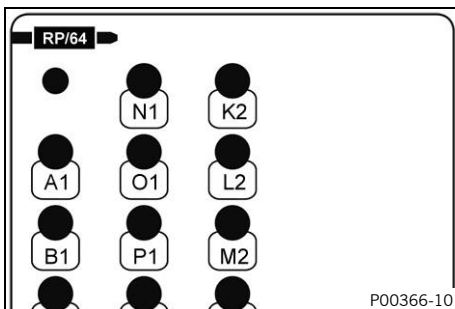

**Exhaust control actuator – check the control wire for a short circuit to ground (terminal 31).**

- Measure the resistance between the specified points.  
Bob box connector **RP** pin **P2** – Measuring point **Ground (-)**

Resistance	∞ Ω
------------	-----

- » If the specifications have not been met:
  - Check the cable from engine control unit connector **RP** (📖 p. 157) pin **P2** to connector **ON** (📖 p. 157) pin **2** for a short circuit to ground (terminal 31).
- » If the specifications have been met:
  - Check the next possible cause:  
Fuel pump – the control wire has a short circuit to sensor ground (📖 p. 105)

### Fuel pump – the control wire has a short circuit to sensor ground

**Condition**

The diagnostics tool is disconnected.

Engine control unit is disconnected. (📖 p. 16)

The break out box is connected to the engine control unit wiring harness with adapter **00029095016**.

Exhaust control actuator is disconnected. (📖 p. 17)

### 3 ENGINE CONTROL TROUBLE CODE

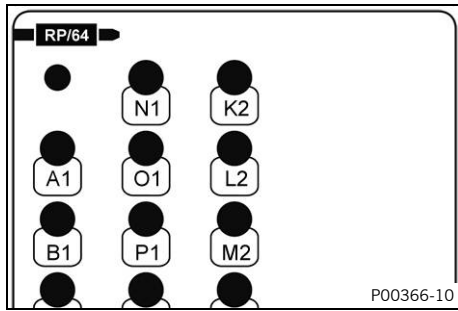

**Exhaust control actuator – check the control wire for a short circuit to sensor ground.**

-  Measure the resistance between the specified points.  
Bob box connector **RP** pin **P2** – Bob box connector **RP** pin **E2**

Resistance	$\infty \Omega$
------------	-----------------

- » If the specifications have not been met:
  - Check cable from engine control unit connector **RP** (📖 p. 157) pin **P2** to connector **ON** (📖 p. 157) pin **2** for a short circuit to sensor ground.
- » If the specifications have been met:
  - Contact customer service.

<b>Blink code for malfunction indicator lamp</b>	<b>Fi</b> 50 Malfunction indicator lamp flashes 5x long
<b>Display on diagnostic tool</b>	P140312 "Exhaust control actuator" "Input signal too high"
<b>Error level condition</b>	Exhaust control actuator – input signal too high
<b>Possible cause</b>	Exhaust control actuator – control wire is faulty (📖 p. 107)
	Exhaust control actuator – the control wire has a short circuit to plus (terminal 30) (📖 p. 108)
	Exhaust control actuator – the control wire has a short circuit to ignition plus (terminal 15) (📖 p. 108)
	Exhaust control actuator – control wire has a short circuit to the sensor power supply (📖 p. 109)
<b>Last measure if none of the documented causes leads to elimination of the fault</b>	– Contact customer service.

## Exhaust control actuator – control wire is faulty

### Condition

The diagnostics tool is disconnected.

Engine control unit is disconnected. (📖 p. 16)

The break out box is connected to the engine control unit wiring harness with adapter **00029095016**.

Exhaust control actuator is disconnected. (📖 p. 17)

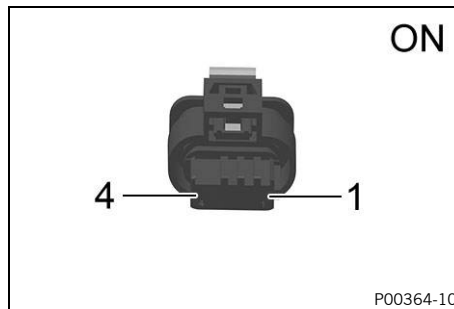
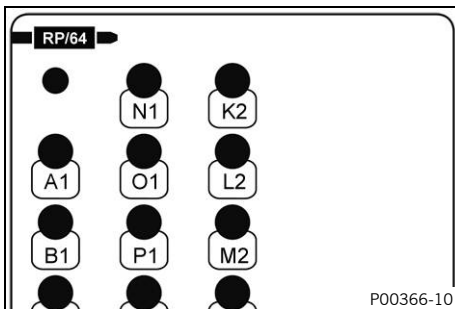

### Exhaust control actuator – check the control wire.

- Measure the resistance between the specified points.  
Bob box connector **RP** pin **P2** – Exhaust control actuator **ON** pin **2**

Resistance	$\leq 0.6 \Omega$
------------	-------------------

- » If the specifications have not been met:
  - Check engine control unit connector **RP** (📖 p. 157) pin **P2** and connector **ON** (📖 p. 157) pin **2**.
  - Check the cable from engine control unit connector **RP** (📖 p. 157) pin **P2** to connector **ON** (📖 p. 157) pin **2**.
- » If the specifications have been met:
  - Check the next possible cause:  
Exhaust control actuator – the control wire has a short circuit to plus (terminal 30) (📖 p. 108)

## Exhaust control actuator – the control wire has a short circuit to plus (terminal 30)

### Condition

The diagnostics tool is disconnected.

Engine control unit is disconnected. (📖 p. 16)

The break out box is connected to the engine control unit wiring harness with adapter **00029095016**.

Exhaust control actuator is disconnected. (📖 p. 17)

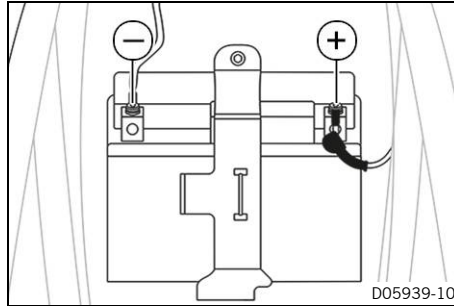
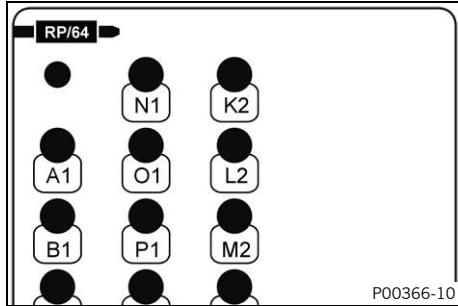

### Exhaust control actuator – check the control wire for a short circuit to plus (terminal 30).

- **V** Measure the voltage between the specified points.  
Bob box connector **RP** pin **P2** – Measuring point **Ground (-)**

Voltage	< 0.1 V
---------	---------

- » If the specifications have not been met:
  - Check the cable from engine control unit connector **RP** (📖 p. 157) pin **P2** to connector **ON** (📖 p. 157) pin **2** for a short circuit to plus (terminal 30).
- » If the specifications have been met:
  - Check the next possible cause:  
Exhaust control actuator – the control wire has a short circuit to ignition plus (terminal 15) (📖 p. 108)

## Exhaust control actuator – the control wire has a short circuit to ignition plus (terminal 15)

### Condition

The diagnostics tool is disconnected.

Engine control unit is disconnected. (📖 p. 16)

The break out box is connected to the engine control unit wiring harness with adapter **00029095016**.

Exhaust control actuator is disconnected. (📖 p. 17)

### Exhaust control actuator – check the control wire for a short circuit to ignition plus (terminal 15).

- **Ω** Measure the resistance between the specified points.  
Bob box connector **RP** pin **P2** – Bob box connector **RP** pin **D4**

Resistance	$\infty \Omega$
------------	-----------------

- » If the specifications have not been met:
  - Check the cable from engine control unit connector **RP** (📖 p. 157) pin **P2** to connector **ON** (📖 p. 157) pin **2** for a short circuit to ignition plus (terminal 15).
- » If the specifications have been met:
  - Check the next possible cause:  
Exhaust control actuator – control wire has a short circuit to the sensor power supply (📖 p. 109)

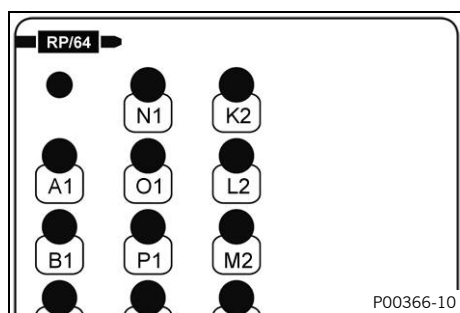

## Exhaust control actuator – control wire has a short circuit to the sensor power supply

### Condition

The diagnostics tool is disconnected.

Engine control unit is disconnected. (📖 p. 16)

The break out box is connected to the engine control unit wiring harness with adapter **00029095016**.

Exhaust control actuator is disconnected. (📖 p. 17)

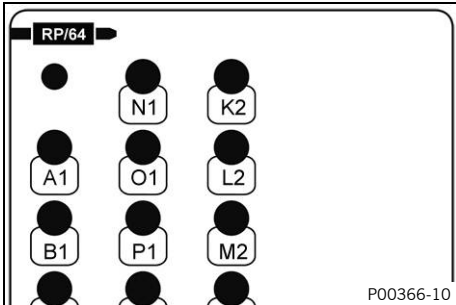

### Exhaust control actuator – check the control wire for a short circuit to the sensor power supply.

-  Measure the resistance between the specified points.  
Bob box connector **RP** pin **P2** – Bob box connector **RP** pin **D3**

Resistance	$\infty \Omega$
------------	-----------------

- » If the specifications have not been met:
  - Check the cable from engine control unit connector **RP** (📖 p. 157) pin **P2** to connector **ON** (📖 p. 157) pin **2** for a short circuit to the sensor power supply.
- » If the specifications have been met:
  - Contact customer service.

## 3 ENGINE CONTROL TROUBLE CODE

<b>Blink code for malfunction indicator lamp</b>	<b>Fi</b> 50 Malfunction indicator lamp flashes 5x long
<b>Display on diagnostic tool</b>	P140477 "Exhaust control actuator" "Mechanical error in the lower position"
<b>Error level condition</b>	Exhaust control actuator – mechanical error in the lower position
<b>Function check</b>	Calibrating the exhaust control actuator (🔧 p. 110)
<b>Last measure if none of the documented causes leads to elimination of the fault</b>	– Change exhaust control actuator.

### Calibrating the exhaust control actuator

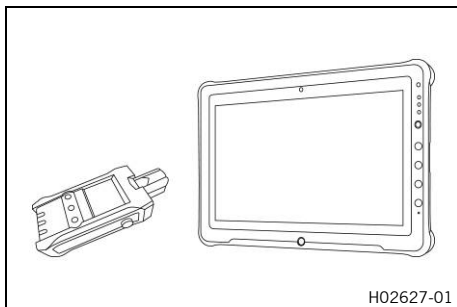

#### Condition

The diagnostics tool is connected and running.

- Execute "**Engine control unit**" > "**Control unit functions**" > "**Teach in exhaust control actuator**".



#### Info

The instructions must be followed precisely.

- » If the specified value is reached:
  - Clear the fault memory using the KTM diagnostics tool.
  - Take a test ride.
  - Read out the fault memory using the KTM diagnostics tool.

#### Last measure if none of the documented causes leads to elimination of the fault

- Change exhaust control actuator.

<b>Blink code for malfunction indicator lamp</b>	<b>Fi</b> 50 Malfunction indicator lamp flashes 5x long
<b>Display on diagnostic tool</b>	P140577 <b>"Exhaust control actuator"</b> <b>"Mechanical error in the upper position"</b>
<b>Error level condition</b>	Exhaust control actuator – mechanical error in the upper position
<b>Function check</b>	Calibrating the exhaust control actuator (🗨 p. 111)
<b>Last measure if none of the documented causes leads to elimination of the fault</b>	– Change exhaust control actuator.

### Calibrating the exhaust control actuator

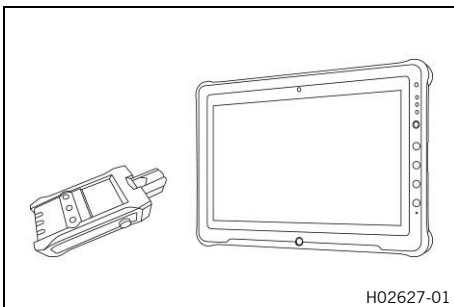

#### Condition

The diagnostics tool is connected and running.

- Execute **"Engine control unit" > "Control unit functions" > "Teach in exhaust control actuator"**.



#### Info

The instructions must be followed precisely.

- » If the specified value is reached:
  - Clear the fault memory using the KTM diagnostics tool.
  - Take a test ride.
  - Read out the fault memory using the KTM diagnostics tool.

#### Last measure if none of the documented causes leads to elimination of the fault

- Change exhaust control actuator.

### 3 ENGINE CONTROL TROUBLE CODE

<b>Blink code for malfunction indicator lamp</b>	<b>Fi</b> 50 Malfunction indicator lamp flashes 5x long
<b>Display on diagnostic tool</b>	P140677 "Exhaust control actuator" "Mechanical error"
<b>Error level condition</b>	Exhaust control actuator – mechanical error
<b>Function check</b>	Checking the exhaust control actuator (📖 p. 112)
<b>Possible cause</b>	Exhaust control actuator has no function (📖 p. 112)
<b>Last measure if none of the documented causes leads to elimination of the fault</b>	– Contact customer service.

#### Checking the exhaust control actuator

##### Condition

The diagnostics tool is connected and running.

- Execute "**Engine control unit**" > "**Actuator test**" > "**Exhaust control actuator**".

The exhaust control actuator audibly moves from the lower to upper stop position.

- » If the specified value is reached:
  - Clear the fault memory using the KTM diagnostics tool.
  - Take a test ride.
  - Read out the fault memory using the KTM diagnostics tool.
- » If the specification is not reached:
  - Check the next possible cause:  
Exhaust control actuator has no function (📖 p. 112)

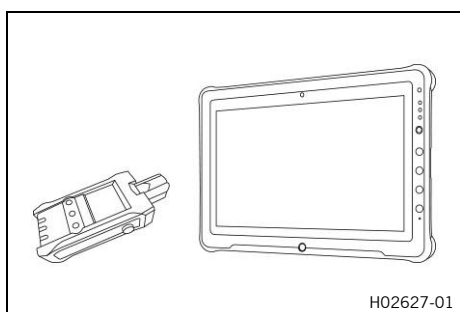

#### Exhaust control actuator has no function

- Check the exhaust control actuator for mechanical damage.

Exhaust control actuator is not damaged.

- » If the specifications have not been met:
  - Change exhaust control actuator.
- » If the specifications have been met:
  - Contact customer service.

<b>Blink code for malfunction indicator lamp</b>	<b>Fi</b> Malfunction indicator lamp lights up
<b>Display on diagnostic tool</b>	P163100 "Tilt sensor" "Input signal too low"
<b>Error level condition</b>	Tilt sensor – input signal too low Signal voltage: $\leq 0.2$ V Signal voltage: 3.7 ... 4.6 V
<b>Possible cause</b>	Tilt sensor – the power supply is faulty (📖 p. 113)
	Tilt sensor – the signal wire has a short circuit to ground (terminal 31) (📖 p. 114)
	Tilt sensor – the signal wire has a short circuit to sensor ground (📖 p. 114)
<b>Last measure if none of the documented causes leads to elimination of the fault</b>	– Contact customer service.

## Tilt sensor – the power supply is faulty

### Condition

The diagnostics tool is connected and running.

Engine control unit is connected. (📖 p. 16)

The tilt sensor is disconnected. (📖 p. 15)

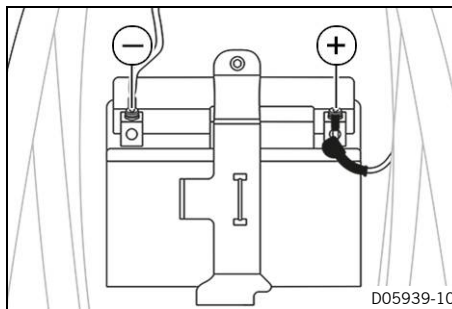
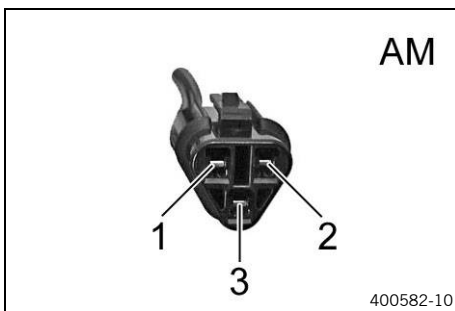

### Tilt sensor – check the power supply.

- **V** Measure the voltage between the specified points.  
Tilt sensor connector **AM** pin **2** – Measuring point **Ground (-)**



#### Info

For the measurement, the measuring points must be subjected to a 12 V/21 W bulb.

Voltage	4.9 ... 5.1 V
---------	---------------

- » If the specifications have not been met:
  - Check connector **AM** (📖 p. 152) pin **2** and pin **1**.
  - Check the cable from connector **AM** (📖 p. 152) pin **2** to the next node in the wiring harness.
  - Check the cable from engine control unit connector **RP** (📖 p. 157) pin **J1** to connector **AM** (📖 p. 152) pin **1**.
- » If the specifications have been met:
  - Check the next possible cause:  
Tilt sensor – the signal wire has a short circuit to ground (terminal 31) (📖 p. 114)

## Tilt sensor – the signal wire has a short circuit to ground (terminal 31)

### Condition

The diagnostics tool is disconnected.

Engine control unit is disconnected. (📖 p. 16)

The break out box is connected to the engine control unit wiring harness with adapter **00029095016**.

The tilt sensor is disconnected. (📖 p. 15)

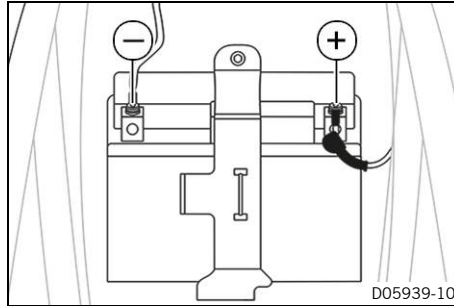
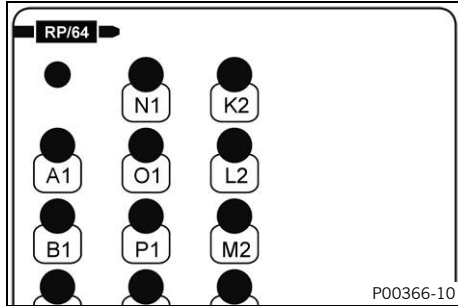

### Side stand sensor – check the signal wire for a short circuit to ground (terminal 31).

- Measure the resistance between the specified points.  
Bob box connector **RP** pin **L2** – Measuring point **Ground (-)**

Resistance	$\infty \Omega$
------------	-----------------

- » If the specifications have not been met:
  - Check the cable from engine control unit connector **RP** (📖 p. 157) pin **L2** to connector **AM** (📖 p. 152) pin **3** for a short circuit to ground (terminal 31).
- » If the specifications have been met:
  - Check the next possible cause:  
Tilt sensor – the signal wire has a short circuit to sensor ground (📖 p. 114)

## Tilt sensor – the signal wire has a short circuit to sensor ground

### Condition

The diagnostics tool is disconnected.

Engine control unit is disconnected. (📖 p. 16)

The break out box is connected to the engine control unit wiring harness with adapter **00029095016**.

The tilt sensor is disconnected. (📖 p. 15)

### Tilt sensor – check the signal wire for a short circuit to sensor ground.

- Measure the resistance between the specified points.  
Bob box connector **RP** pin **L2** – Bob box connector **RP** pin **J1**

Resistance	$\infty \Omega$
------------	-----------------

- » If the specifications have not been met:
  - Check cable from engine control unit connector **RP** (📖 p. 157) pin **L2** to connector **AM** (📖 p. 152) pin **3** for a short circuit to sensor ground.
- » If the specifications have been met:
  - Contact customer service.

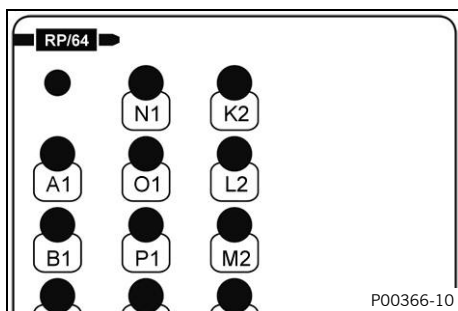

<b>Blink code for malfunction indicator lamp</b>	<b>Fi</b> Malfunction indicator lamp lights up
<b>Display on diagnostic tool</b>	P163200 "Tilt sensor" "Input signal too high"
<b>Error level condition</b>	Tilt sensor – input signal too high Voltage: $\geq 4.8$ V
<b>Possible cause</b>	Tilt sensor – the signal wire has a short circuit to plus (terminal 30) (📖 p. 115)
	Tilt sensor – the signal wire has a short circuit to ignition plus (terminal 15) (📖 p. 116)
	Tilt sensor – the signal wire has a short circuit to the sensor power supply (📖 p. 116)
	Tilt sensor – the signal wire is faulty (📖 p. 116)
	Tilt sensor – the ground wire is faulty (📖 p. 117)
<b>Last measure if none of the documented causes leads to elimination of the fault</b>	– Contact customer service.

### Tilt sensor – the signal wire has a short circuit to plus (terminal 30)

#### Condition

The diagnostics tool is disconnected.

Engine control unit is disconnected. (📖 p. 16)

The break out box is connected to the engine control unit wiring harness with adapter **00029095016**.

The tilt sensor is disconnected. (📖 p. 15)

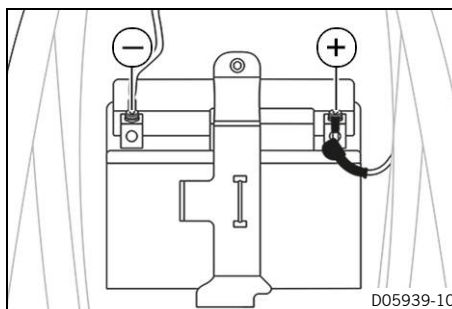
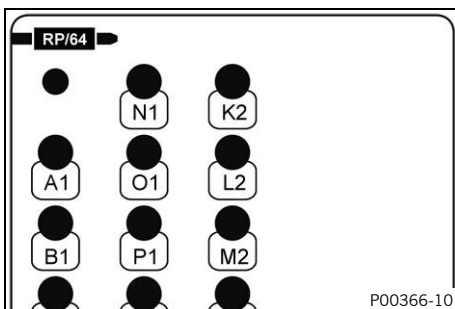

#### Tilt sensor – check the signal wire for a short circuit to plus (terminal 30).

- **V** Measure the voltage between the specified points.  
Bob box connector **RP** pin **L2** – Measuring point **Ground (-)**

Voltage	$< 0.1$ V
---------	-----------

- » If the specifications have not been met:
  - Check the cable from engine control unit connector **RP** (📖 p. 157) pin **L2** to connector **AM** (📖 p. 152) pin **3** for a short circuit to plus (terminal 30).
- » If the specifications have been met:
  - Check the next possible cause:  
Tilt sensor – the signal wire has a short circuit to ignition plus (terminal 15) (📖 p. 116)

### 3 ENGINE CONTROL TROUBLE CODE

#### Tilt sensor – the signal wire has a short circuit to ignition plus (terminal 15)

##### Condition

The diagnostics tool is disconnected.

Engine control unit is disconnected. (📖 p. 16)

The break out box is connected to the engine control unit wiring harness with adapter **00029095016**.

The tilt sensor is disconnected. (📖 p. 15)

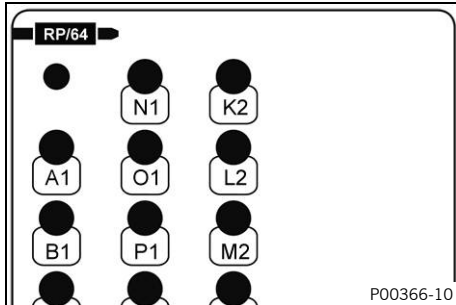

#### Tilt sensor – check the signal wire for a short circuit to ignition plus (terminal 15).

-  Measure the resistance between the specified points.  
Bob box connector **RP** pin **L2** – Bob box connector **RP** pin **D4**

Resistance	$\infty \Omega$
------------	-----------------

- » If the specifications have not been met:
  - Check the cable from engine control unit connector **RP** (📖 p. 157) pin **L2** to connector **AM** (📖 p. 152) pin **3** for a short circuit to ignition plus (terminal 15).
- » If the specifications have been met:
  - Check the next possible cause:  
Tilt sensor – the signal wire has a short circuit to the sensor power supply (📖 p. 116)

#### Tilt sensor – the signal wire has a short circuit to the sensor power supply

##### Condition

The diagnostics tool is disconnected.

Engine control unit is disconnected. (📖 p. 16)

The break out box is connected to the engine control unit wiring harness with adapter **00029095016**.

The tilt sensor is disconnected. (📖 p. 15)

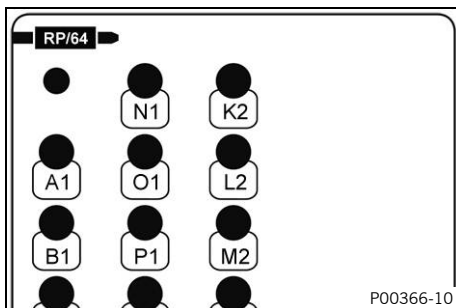

#### Tilt sensor – check the signal wire for a short circuit to the sensor power supply.

-  Measure the resistance between the specified points.  
Bob box connector **RP** pin **L2** – Bob box connector **RP** pin **D3**

Resistance	$\infty \Omega$
------------	-----------------

- » If the specifications have not been met:
  - Check the cable from engine control unit connector **RP** (📖 p. 157) pin **L2** to connector **AM** (📖 p. 152) pin **3** for a short circuit to the sensor power supply.
- » If the specifications have been met:
  - Check the next possible cause:  
Tilt sensor – the signal wire is faulty (📖 p. 116)

#### Tilt sensor – the signal wire is faulty

##### Condition

The diagnostics tool is disconnected.

Engine control unit is disconnected. (📖 p. 16)

The break out box is connected to the engine control unit wiring harness with adapter **00029095016**.

The tilt sensor is disconnected. (📖 p. 15)

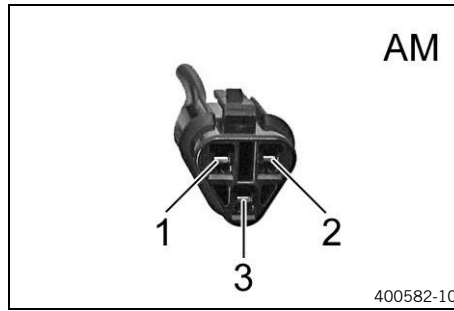
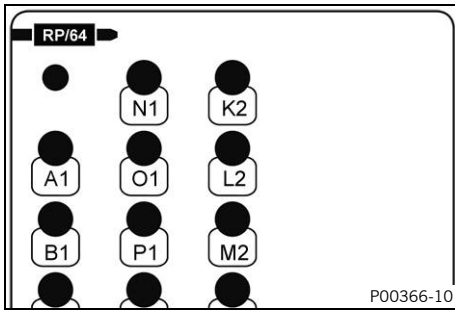

### Tilt sensor – check the signal wire.

- Measure the resistance between the specified points.  
Bob box connector **RP** pin **L2** – Tilt sensor connector **AM** pin **3**

Resistance	$\leq 0.6 \Omega$
------------	-------------------

- » If the specifications have not been met:
  - Check engine control unit connector **RP** (p. 157) pin **L2** and connector **AM** (p. 152) pin **3**.
  - Check the cable from engine control unit connector **RP** (p. 157) pin **L2** to connector **AM** (p. 152) pin **3**.
- » If the specifications have been met:
  - Check the next possible cause:  
Tilt sensor – the ground wire is faulty (p. 117)

### Tilt sensor – the ground wire is faulty

#### Condition

The diagnostics tool is disconnected.

Engine control unit is disconnected. (p. 16)

The break out box is connected to the engine control unit wiring harness with adapter **00029095016**.

The tilt sensor is disconnected. (p. 15)

Crankcase pressure sensor is disconnected. (p. 12)

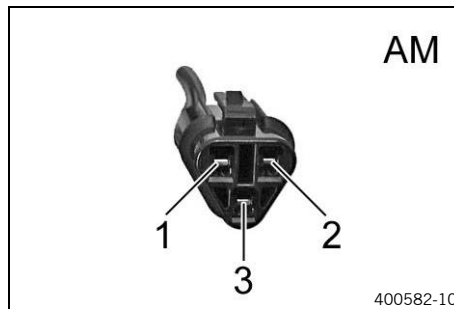
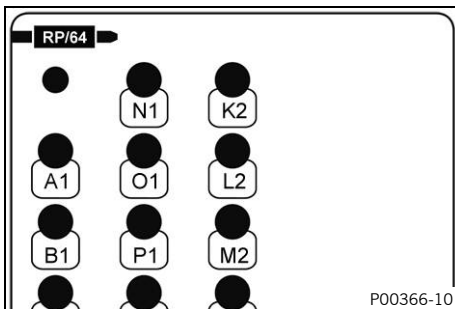

### Tilt sensor – check the ground wire.

- Measure the resistance between the specified points.  
Bob box connector **RP** pin **J1** – Tilt sensor connector **AM** pin **1**

Resistance	$\leq 0.6 \Omega$
------------	-------------------

- » If the specifications have not been met:
  - Check engine control unit connector **RP** (p. 157) pin **J1** and connector **AM** (p. 152) pin **1**.
  - Check the cable from engine control unit connector **RP** (p. 157) pin **J1** to connector **AM** (p. 152) pin **1**.
- » If the specifications have been met:
  - Contact customer service.

## 4 TROUBLE CODE, CONNECTIVITY UNIT

<b>Connectivity Unit blink code</b>	 Indicator lamp flashes red once
<b>Display on diagnostic tool</b>	B10F149 "Connectivity Unit" "Accelerator sensor malfunction"
<b>Error level condition</b>	Accelerator sensor malfunction
<b>Function check</b>	Resetting the Connectivity Unit (📖 p. 118)
<b>Last measure if none of the documented causes leads to elimination of the fault</b>	– Contact customer service.

### Resetting the Connectivity Unit

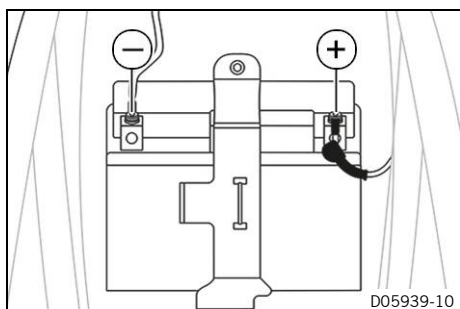

- Disconnect the negative terminal of the 12-V battery.
- Wait for 10 minutes.
- Connect the negative terminal of the 12-V battery.
- Clear the fault memory using the KTM diagnostics tool.
- Disconnect the diagnostics tool for 30 seconds.
- Read out the fault memory using the KTM diagnostics tool.
  - » If the error persists:
    - Change the Connectivity Unit.

**Last measure if none of the documented causes leads to elimination of the fault**

- Contact customer service.

<b>Connectivity Unit blink code</b>	 Indicator lamp flashes red once
<b>Display on diagnostic tool</b>	B10F349 "Connectivity Unit" "GPS sensor malfunction"
<b>Error level condition</b>	GPS sensor malfunction
<b>Function check</b>	Resetting the Connectivity Unit (📖 p. 119)
<b>Last measure if none of the documented causes leads to elimination of the fault</b>	– Contact customer service.

### Resetting the Connectivity Unit

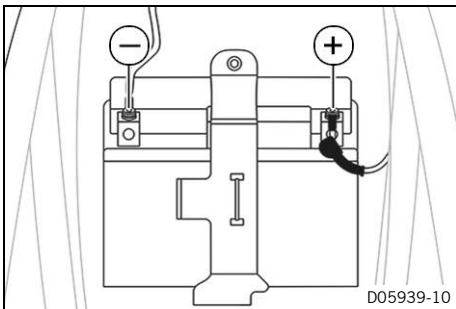

- Disconnect the negative terminal of the 12-V battery.
- Wait for 10 minutes.
- Connect the negative terminal of the 12-V battery.
- Clear the fault memory using the KTM diagnostics tool.
- Disconnect the diagnostics tool for 30 seconds.
- Read out the fault memory using the KTM diagnostics tool.
  - » If the error persists:
    - Change the Connectivity Unit.

**Last measure if none of the documented causes leads to elimination of the fault**

- Contact customer service.

## 4 TROUBLE CODE, CONNECTIVITY UNIT

<b>Connectivity Unit blink code</b>	 Indicator lamp flashes red four times
<b>Display on diagnostic tool</b>	B10F449 "Connectivity Unit" "Bluetooth malfunction"
<b>Error level condition</b>	Bluetooth malfunction
<b>Function check</b>	Resetting the Connectivity Unit (📖 p. 120)
<b>Last measure if none of the documented causes leads to elimination of the fault</b>	– Contact customer service.

### Resetting the Connectivity Unit

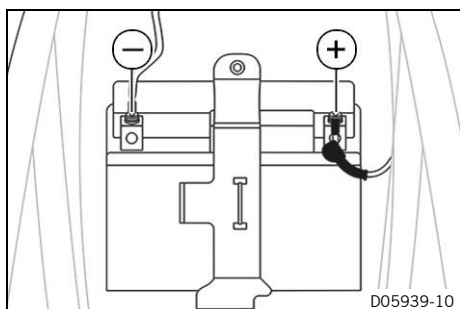

- Disconnect the negative terminal of the 12-V battery.
- Wait for 10 minutes.
- Connect the negative terminal of the 12-V battery.
- Clear the fault memory using the KTM diagnostics tool.
- Disconnect the diagnostics tool for 30 seconds.
- Read out the fault memory using the KTM diagnostics tool.
  - » If the error persists:
    - Change the Connectivity Unit.

**Last measure if none of the documented causes leads to elimination of the fault**

- Contact customer service.

<b>Connectivity Unit blink code</b>	 Indicator lamp flashes red three times
<b>Display on diagnostic tool</b>	B10F549 "Connectivity Unit" "WLAN malfunction"
<b>Error level condition</b>	WLAN malfunction
<b>Function check</b>	Resetting the Connectivity Unit (📖 p. 121)
<b>Last measure if none of the documented causes leads to elimination of the fault</b>	– Contact customer service.

### Resetting the Connectivity Unit

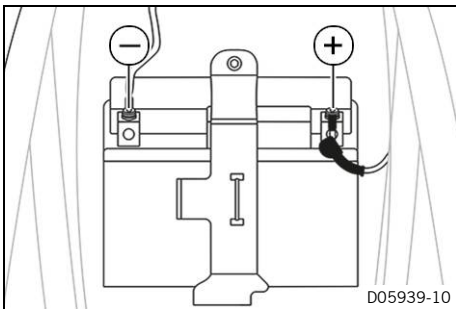

- Disconnect the negative terminal of the 12-V battery.
- Wait for 10 minutes.
- Connect the negative terminal of the 12-V battery.
- Clear the fault memory using the KTM diagnostics tool.
- Disconnect the diagnostics tool for 30 seconds.
- Read out the fault memory using the KTM diagnostics tool.
  - » If the error persists:
    - Change the Connectivity Unit.

**Last measure if none of the documented causes leads to elimination of the fault**

- Contact customer service.

## 4 TROUBLE CODE, CONNECTIVITY UNIT

<b>Connectivity Unit blink code</b>	 Indicator lamp flashes red once
<b>Display on diagnostic tool</b>	B10F649 "Connectivity Unit" "LED malfunction"
<b>Error level condition</b>	LED malfunction
<b>Function check</b>	Resetting the Connectivity Unit (📖 p. 122)
<b>Last measure if none of the documented causes leads to elimination of the fault</b>	– Contact customer service.

### Resetting the Connectivity Unit

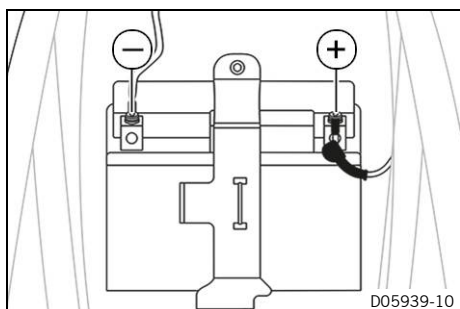

- Disconnect the negative terminal of the 12-V battery.
- Wait for 10 minutes.
- Connect the negative terminal of the 12-V battery.
- Clear the fault memory using the KTM diagnostics tool.
- Disconnect the diagnostics tool for 30 seconds.
- Read out the fault memory using the KTM diagnostics tool.
  - » If the error persists:
    - Change the Connectivity Unit.

**Last measure if none of the documented causes leads to elimination of the fault**

- Contact customer service.

<b>Connectivity Unit blink code</b>	 Indicator lamp flashes red once
<b>Display on diagnostic tool</b>	B10F701 "Connectivity Unit" "Button malfunction"
<b>Error level condition</b>	Button pressed for more than 60 seconds
<b>Function check</b>	Resetting the Connectivity Unit (📖 p. 123)
<b>Last measure if none of the documented causes leads to elimination of the fault</b>	– Contact customer service.

### Resetting the Connectivity Unit

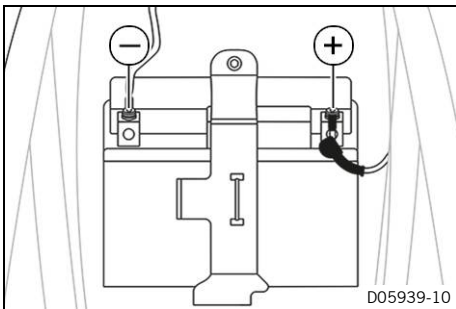

- Disconnect the negative terminal of the 12-V battery.
- Wait for 10 minutes.
- Connect the negative terminal of the 12-V battery.
- Clear the fault memory using the KTM diagnostics tool.
- Disconnect the diagnostics tool for 30 seconds.
- Read out the fault memory using the KTM diagnostics tool.
  - » If the error persists:
    - Change the Connectivity Unit.

**Last measure if none of the documented causes leads to elimination of the fault**

- Contact customer service.

## 4 TROUBLE CODE, CONNECTIVITY UNIT

<b>Connectivity Unit blink code</b>	 Indicator lamp flashes red once
<b>Display on diagnostic tool</b>	B10F842 "Connectivity Unit" "Memory faulty"
<b>Error level condition</b>	Memory faulty
<b>Function check</b>	Resetting the Connectivity Unit (📖 p. 124)
<b>Last measure if none of the documented causes leads to elimination of the fault</b>	– Contact customer service.

### Resetting the Connectivity Unit

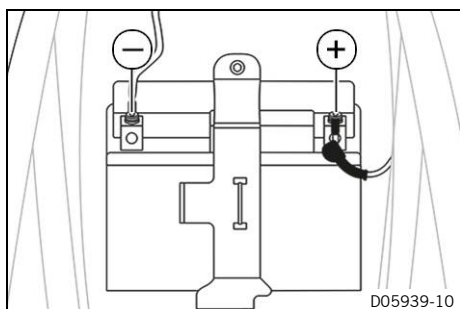

- Disconnect the negative terminal of the 12-V battery.
- Wait for 10 minutes.
- Connect the negative terminal of the 12-V battery.
- Clear the fault memory using the KTM diagnostics tool.
- Disconnect the diagnostics tool for 30 seconds.
- Read out the fault memory using the KTM diagnostics tool.
  - » If the error persists:
    - Change the Connectivity Unit.

**Last measure if none of the documented causes leads to elimination of the fault**

- Contact customer service.

<b>Connectivity Unit blink code</b>	 Indicator lamp flashes red once
<b>Display on diagnostic tool</b>	B10FB13 "Control wire, power relay" "Open circuit"
<b>Error level condition</b>	Control wire, power relay – circuit interrupted
<b>Possible cause</b>	Power relay – the control wire is faulty (📖 p. 125)
	Power relay – the control wire has a short circuit to plus (terminal 30) (📖 p. 125)
	Power relay – the control wire has a short circuit to ground (terminal 31) (📖 p. 126)
<b>Last measure if none of the documented causes leads to elimination of the fault</b>	– Contact customer service.

## Power relay – the control wire is faulty

### Condition

- The diagnostics tool is disconnected.
- Engine control unit is disconnected. (📖 p. 16)
- Connectivity Unit is disconnected. (📖 p. 17)
- Voltage regulator is disconnected.
- Power relay is disconnected.

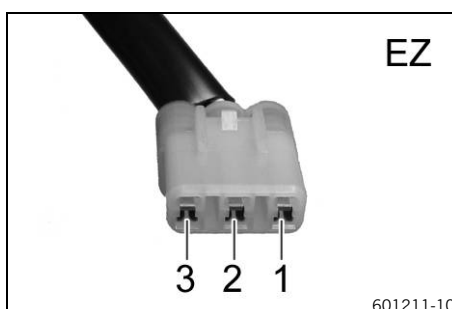
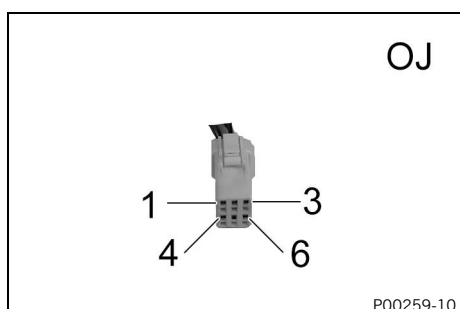

### Power relay – check the control wire.

-  Measure the resistance between the specified points.  
 Connectivity Unit connector **OJ** pin **5** – Voltage regulator connector **EZ** pin **1**

Resistance	$\leq 0.6 \Omega$
------------	-------------------

- » If the specifications have not been met:
  - Check the cable from engine control unit connector **OJ** (📖 p. 156) pin **5** to connector **EZ** (📖 p. 154) pin **1**.
- » If the specifications have been met:
  - Check the next possible cause:  
 Power relay – the control wire has a short circuit to plus (terminal 30) (📖 p. 125)

## Power relay – the control wire has a short circuit to plus (terminal 30)

### Condition

- The diagnostics tool is disconnected.
- Connectivity Unit is disconnected. (📖 p. 17)

## 4 TROUBLE CODE, CONNECTIVITY UNIT

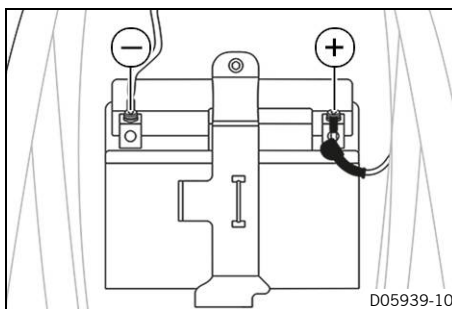
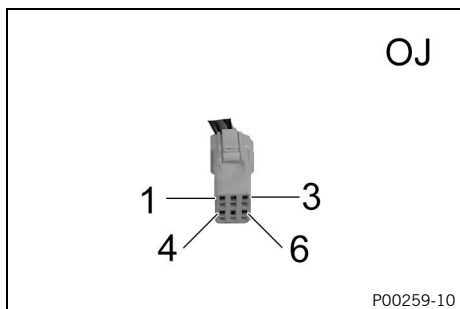

### Power relay – check the control wire for a short circuit to plus (terminal 30).

- **V** Measure the voltage between the specified points.  
Connectivity Unit connector **OJ** pin **5** – Measuring point **Ground (-)**

Voltage	< 0.1 V
---------	---------

- » If the specifications have not been met:
  - Check the cable from connector **OJ** (p. 156) pin **5** against the wiring diagram for a short circuit to plus (terminal 30).
- » If the specifications have been met:
  - Check the next possible cause:  
Power relay – the control wire has a short circuit to ground (terminal 31) (p. 126)

### Power relay – the control wire has a short circuit to ground (terminal 31)

#### Condition

The diagnostics tool is disconnected.  
 Engine control unit is disconnected. (p. 16)  
 Connectivity Unit is disconnected. (p. 17)  
 Voltage regulator is disconnected.  
 Power relay is disconnected.

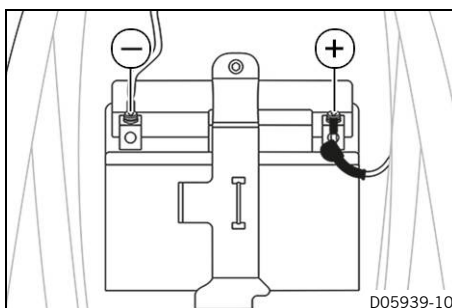
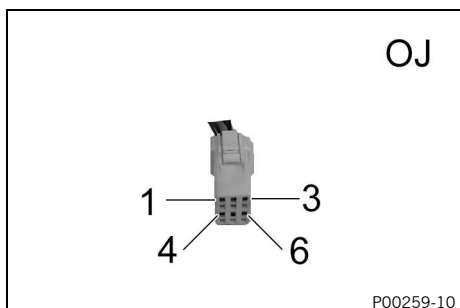

### Power relay – check the control wire for a short circuit to ground (terminal 31).

- **Ω** Measure the resistance between the specified points.  
Connectivity Unit connector **OJ** pin **5** – Measuring point **Ground (-)**

Resistance	$\infty \Omega$
------------	-----------------

- » If the specifications have not been met:
  - Check the cable from connector **OJ** (p. 156) pin **5** against the wiring diagram for a short circuit to ground (terminal 31).
- » If the specifications have been met:
  - Contact customer service.

<b>Connectivity Unit blink code</b>	 Indicator lamp flashes red once
<b>Display on diagnostic tool</b>	B10FC17 "Connectivity Unit" "Power supply exceeded"
<b>Error level condition</b>	Power supply exceeded Voltage: $\geq 16$ V
<b>Function check</b>	Checking the charging voltage (📖 p. 127)
<b>Last measure if none of the documented causes leads to elimination of the fault</b>	– Contact customer service.

## Checking the charging voltage

### Condition

The 12-V battery must be fully functional and completely charged.

- Remove the seat.
- Start the motorcycle to check the function.

- **V** Measure the voltage between the specified points.  
 Measuring point **plus (+)** – Measuring point **Ground (–)**

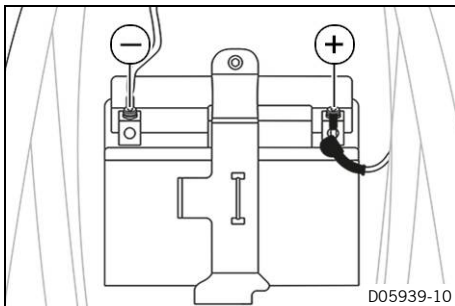

Charging voltage	
5,000 rpm	13.5 ... 15.0 V

- » If the displayed value is less than the specified value:
  - Check the plug-in connections from the alternator to the voltage regulator.
  - Check the plug-in connections from the voltage regulator to the wiring harness.
  - Check the stator of the ignition.
- » If the displayed value is greater than the specified value:
  - Change voltage regulator.

### Last measure if none of the documented causes leads to elimination of the fault

- Contact customer service.

## 4 TROUBLE CODE, CONNECTIVITY UNIT

<b>Connectivity Unit blink code</b>	 Indicator lamp flashes red once
<b>Display on diagnostic tool</b>	B10FD16 "Connectivity Unit" "Power supply below specification"
<b>Error level condition</b>	Power supply below specification Voltage: $\leq 8$ V
<b>Possible cause</b>	Connectivity Unit – power supply 1 is faulty (📖 p. 128) Connectivity Unit – power supply 2 is faulty (📖 p. 128)
<b>Last measure if none of the documented causes leads to elimination of the fault</b>	– Contact customer service.

### Connectivity Unit – power supply 1 is faulty

#### Condition

The diagnostics tool is connected and running.  
Connectivity Unit is disconnected. (📖 p. 17)

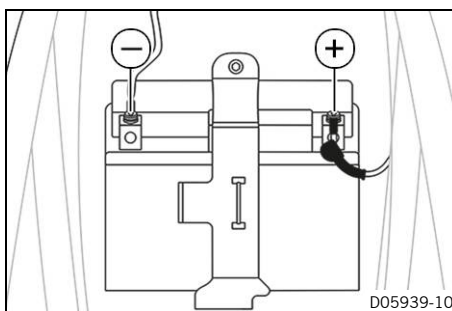
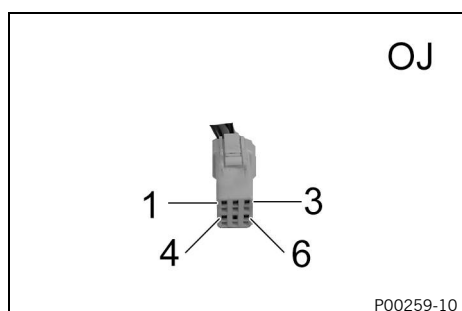

#### Connectivity Unit – check power supply 1.

-  Measure the voltage between the specified points.  
Connectivity Unit connector **OJ** pin **1** – Measuring point **Ground (-)**



#### Info

For the measurement, the measuring points must be subjected to a 12 V/21 W bulb.

The value must not deviate from the battery voltage "**VBAT**" by more than 1 V.

- » If the specifications have not been met:
  - Check connector **OJ** (📖 p. 156) pin **1**.
  - Check the cable from connector **OJ** (📖 p. 156) pin **1** to the next node in the wiring harness.
- » If the specifications have been met:
  - Check the next possible cause:  
Connectivity Unit – power supply 2 is faulty (📖 p. 128)

### Connectivity Unit – power supply 2 is faulty

#### Condition

The diagnostics tool is connected and running.  
Connectivity Unit is disconnected. (📖 p. 17)

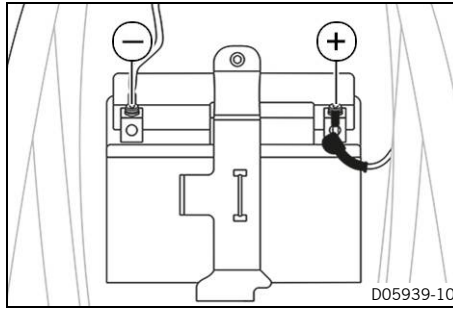
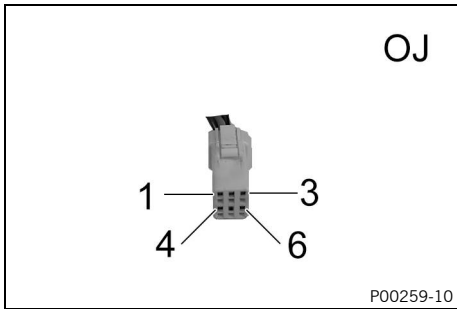

### Connectivity Unit – check power supply 2.

- **V** Measure the voltage between the specified points.  
Connectivity Unit connector **OJ** pin **6** – Measuring point **Ground (-)**



#### Info

For the measurement, the measuring points must be subjected to a 12 V/21 W bulb.

The value must not deviate from the battery voltage "**VBAT**" by more than 1 V.

- » If the specifications have not been met:
  - Check connector **OJ** (📖 p. 156) pin **6**.
  - Check the cable from connector **OJ** (📖 p. 156) pin **6** to the next node in the wiring harness.
- » If the specifications have been met:
  - Contact customer service.

## 4 TROUBLE CODE, CONNECTIVITY UNIT

<b>Connectivity Unit blink code</b>	 Indicator lamp flashes red once
<b>Display on diagnostic tool</b>	B10FE4B "Connectivity Unit" "Temperature too high"
<b>Error level condition</b>	Temperature too high Temperature: $\geq 70$ °C ( $\geq 158$ °F)
<b>Function check</b>	Checking the Connectivity Unit temperature (📖 p. 130)
<b>Last measure if none of the documented causes leads to elimination of the fault</b>	– Contact customer service.

### Checking the Connectivity Unit temperature

#### Condition

The diagnostics tool is connected and running.

- Check the plausibility of the Connectivity Unit temperature being exceeded.

#### Guideline

Result is plausible.

- » If the specified value is reached:
  - Clear the fault memory using the KTM diagnostics tool.
  - Read out the fault memory using the KTM diagnostics tool.
- » If the specification is not reached:
  - Change Connectivity Unit.

#### Last measure if none of the documented causes leads to elimination of the fault

- Contact customer service.

<b>Connectivity Unit blink code</b>	 Indicator lamp flashes red once
<b>Display on diagnostic tool</b>	B10FF00 "Connectivity Unit" "Temperature too low"
<b>Error level condition</b>	Temperature too low Temperature: $\leq -10$ °C ( $\leq 14$ °F)
<b>Function check</b>	Checking the Connectivity Unit temperature (📖 p. 131)
<b>Last measure if none of the documented causes leads to elimination of the fault</b>	– Contact customer service.

### Checking the Connectivity Unit temperature

#### Condition

The diagnostics tool is connected and running.

- Check the plausibility of the Connectivity Unit temperature being exceeded.

#### Guideline

Result is plausible.
----------------------

- » If the specified value is reached:
  - Clear the fault memory using the KTM diagnostics tool.
  - Read out the fault memory using the KTM diagnostics tool.
- » If the specification is not reached:
  - Change Connectivity Unit.

#### Last measure if none of the documented causes leads to elimination of the fault

- Contact customer service.

## 4 TROUBLE CODE, CONNECTIVITY UNIT

<b>Connectivity Unit blink code</b>	 Indicator lamp flashes red once
<b>Display on diagnostic tool</b>	B110092 "Connectivity Unit" "CPU overload"
<b>Error level condition</b>	CPU overload
<b>Function check</b>	Resetting the Connectivity Unit (📖 p. 132)
<b>Last measure if none of the documented causes leads to elimination of the fault</b>	– Contact customer service.

### Resetting the Connectivity Unit

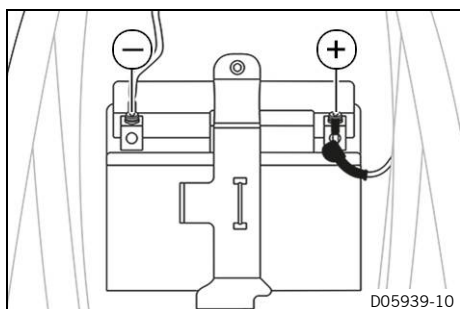

- Disconnect the negative terminal of the 12-V battery.
- Wait for 10 minutes.
- Connect the negative terminal of the 12-V battery.
- Clear the fault memory using the KTM diagnostics tool.
- Disconnect the diagnostics tool for 30 seconds.
- Read out the fault memory using the KTM diagnostics tool.
  - » If the error persists:
    - Change the Connectivity Unit.

**Last measure if none of the documented causes leads to elimination of the fault**

- Contact customer service.

<b>Connectivity Unit blink code</b>	 Indicator lamp flashes red once
<b>Display on diagnostic tool</b>	B110192 "Connectivity Unit" "RAM overload"
<b>Error level condition</b>	RAM overload
<b>Function check</b>	Resetting the Connectivity Unit (📖 p. 133)
<b>Last measure if none of the documented causes leads to elimination of the fault</b>	– Contact customer service.

### Resetting the Connectivity Unit

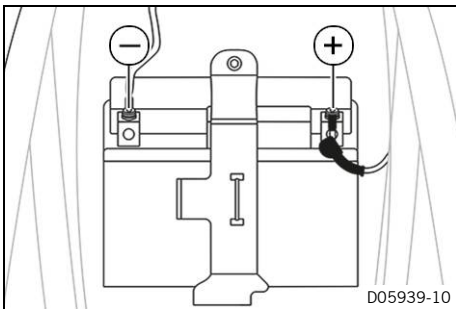

- Disconnect the negative terminal of the 12-V battery.
- Wait for 10 minutes.
- Connect the negative terminal of the 12-V battery.
- Clear the fault memory using the KTM diagnostics tool.
- Disconnect the diagnostics tool for 30 seconds.
- Read out the fault memory using the KTM diagnostics tool.
  - » If the error persists:
    - Change the Connectivity Unit.

#### **Last measure if none of the documented causes leads to elimination of the fault**

- Contact customer service.

## 4 TROUBLE CODE, CONNECTIVITY UNIT

<b>Connectivity Unit blink code</b>	 Indicator lamp flashes red seven times
<b>Display on diagnostic tool</b>	B110292 "Connectivity Unit" "ROM overload"
<b>Error level condition</b>	ROM overload
<b>Function check</b>	Resetting the Connectivity Unit (📖 p. 134)
<b>Last measure if none of the documented causes leads to elimination of the fault</b>	– Contact customer service.

### Resetting the Connectivity Unit

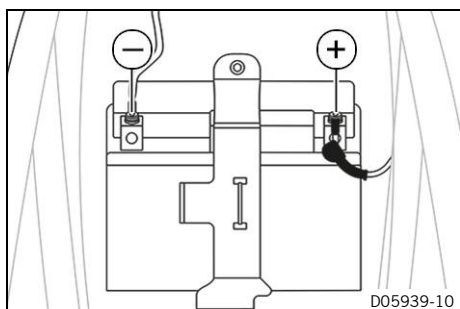

- Disconnect the negative terminal of the 12-V battery.
- Wait for 10 minutes.
- Connect the negative terminal of the 12-V battery.
- Clear the fault memory using the KTM diagnostics tool.
- Disconnect the diagnostics tool for 30 seconds.
- Read out the fault memory using the KTM diagnostics tool.
  - » If the error persists:
    - Change the Connectivity Unit.

**Last measure if none of the documented causes leads to elimination of the fault**

- Contact customer service.

<b>Connectivity Unit blink code</b>	 Indicator lamp flashes red six times
<b>Display on diagnostic tool</b>	B110300 "Connectivity Unit" "Deviation in VIN"
<b>Error level condition</b>	VIN does not match
<b>Function check</b>	Resetting Connectivity Unit to factory settings (🔧 p. 135)
<b>Last measure if none of the documented causes leads to elimination of the fault</b>	– Contact customer service.

### Resetting Connectivity Unit to factory settings

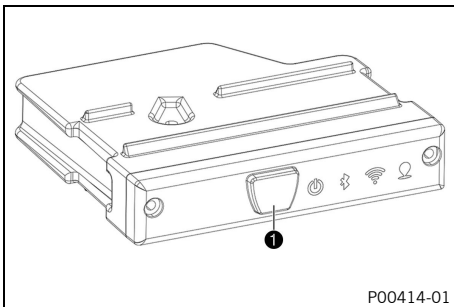

- Press and hold the ❶ button (6 s...12 s) – the Connectivity Unit is prepared for being reset to factory settings.
- Press and hold the ❶ button (12 s...18 s) – the Connectivity Unit is reset to factory settings.
- Reconnect the Connectivity Unit to the app on the smartphone.
- Clear the fault memory using the KTM diagnostics tool.
- Disconnect the diagnostics tool for 30 seconds.
- Read out the fault memory using the KTM diagnostics tool.
  - » If the error persists:
    - Change the Connectivity Unit.

**Last measure if none of the documented causes leads to elimination of the fault**

- Contact customer service.

## 4 TROUBLE CODE, CONNECTIVITY UNIT

<b>Connectivity Unit blink code</b>	 Indicator lamp flashes red eight times
<b>Display on diagnostic tool</b>	B110600 "Connectivity Unit" "Reset with active fuse"
<b>Error level condition</b>	Attempt a reset with active fuse
<b>Function check</b>	Resetting the Connectivity Unit (📖 p. 136)
<b>Last measure if none of the documented causes leads to elimination of the fault</b>	– Contact customer service.

### Resetting the Connectivity Unit

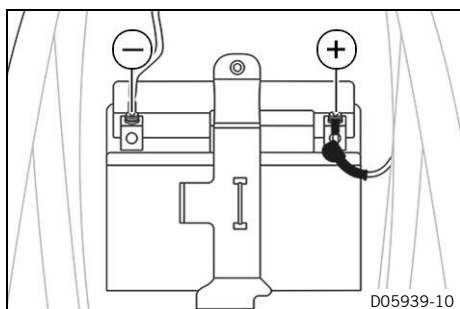

- Disconnect the negative terminal of the 12-V battery.
- Wait for 10 minutes.
- Connect the negative terminal of the 12-V battery.
- Clear the fault memory using the KTM diagnostics tool.
- Disconnect the diagnostics tool for 30 seconds.
- Read out the fault memory using the KTM diagnostics tool.
  - » If the error persists:
    - Change the Connectivity Unit.

**Last measure if none of the documented causes leads to elimination of the fault**

- Contact customer service.

<b>Connectivity Unit blink code</b>	 Indicator lamp flashes red once
<b>Display on diagnostic tool</b>	B110744 "Connectivity Unit" "Data storage error"
<b>Error level condition</b>	Flash storage formatted due to storage damage
<b>Function check</b>	Resetting the Connectivity Unit (📖 p. 137)
<b>Last measure if none of the documented causes leads to elimination of the fault</b>	– Contact customer service.

### Resetting the Connectivity Unit

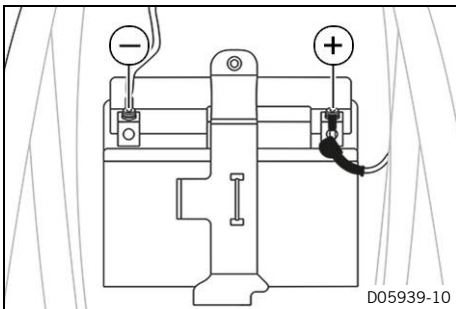

- Disconnect the negative terminal of the 12-V battery.
- Wait for 10 minutes.
- Connect the negative terminal of the 12-V battery.
- Clear the fault memory using the KTM diagnostics tool.
- Disconnect the diagnostics tool for 30 seconds.
- Read out the fault memory using the KTM diagnostics tool.
  - » If the error persists:
    - Change the Connectivity Unit.

**Last measure if none of the documented causes leads to elimination of the fault**

- Contact customer service.

## 4 TROUBLE CODE, CONNECTIVITY UNIT

<b>Connectivity Unit blink code</b>	 Indicator lamp flashes red twice
<b>Display on diagnostic tool</b>	U100288 "Connectivity Unit" "CAN bus communication faulty"
<b>Error level condition</b>	CAN bus communication faulty
<b>Possible cause</b>	Check the CAN bus total resistance (🔧 p. 138)
<b>Last measure if none of the documented causes leads to elimination of the fault</b>	– Contact customer service.

### Check the CAN bus total resistance

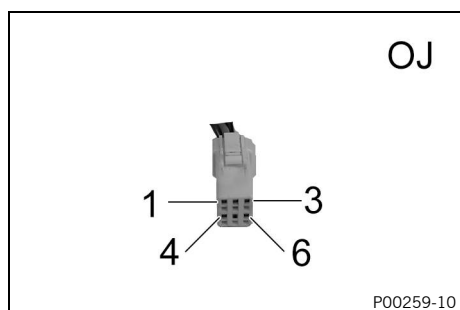

#### Condition

The diagnostics tool is disconnected.  
Connectivity Unit is disconnected. (🔧 p. 17)

#### CAN bus total resistance – check the resistance.

-  Measure the resistance between the specified points.  
Connectivity Unit connector **OJ** pin **2** – Connectivity Unit connector **OJ** pin **3**

CAN bus total resistance	
Resistance on connected engine control unit and CAN bus terminating resistor: 20 °C (68 °F)	54 ... 66 Ω

- » If the specifications have not been met:
  - Check the CAN bus wires.
- » If the specifications have been met:
  - Contact customer service.

<b>Connectivity Unit blink code</b>	 Indicator lamp flashes red twice
<b>Display on diagnostic tool</b>	U100408 "Connectivity Unit" "Faulty CAN bus communication with engine control unit"
<b>Error level condition</b>	Faulty CAN bus communication with engine control unit
<b>Possible cause</b>	Check the CAN bus total resistance (📖 p. 139)
<b>Last measure if none of the documented causes leads to elimination of the fault</b>	– Contact customer service.

## Check the CAN bus total resistance

### Condition

The diagnostics tool is disconnected.  
 Connectivity Unit is disconnected. (📖 p. 17)

### CAN bus total resistance – check the resistance.

-  Measure the resistance between the specified points.  
 Connectivity Unit connector **OJ** pin **2** – Connectivity Unit connector **OJ** pin **3**

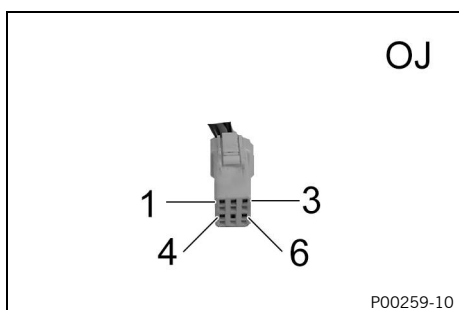

CAN bus total resistance	
Resistance on connected engine control unit and CAN bus terminating resistor: 20 °C (68 °F)	54 ... 66 Ω

- » If the specifications have not been met:
  - Check the CAN bus wires.
- » If the specifications have been met:
  - Contact customer service.

## 4 TROUBLE CODE, CONNECTIVITY UNIT

<b>Connectivity Unit blink code</b>	 Indicator lamp flashes red once
<b>Display on diagnostic tool</b>	U101201 "Connectivity Unit" "CAN bus hardware communication faulty"
<b>Error level condition</b>	CAN bus driver faulty
<b>Function check</b>	Resetting the Connectivity Unit (📖 p. 140)
<b>Last measure if none of the documented causes leads to elimination of the fault</b>	– Contact customer service.

### Resetting the Connectivity Unit

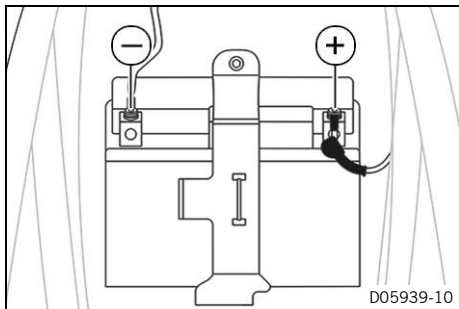

- Disconnect the negative terminal of the 12-V battery.
- Wait for 10 minutes.
- Connect the negative terminal of the 12-V battery.
- Clear the fault memory using the KTM diagnostics tool.
- Disconnect the diagnostics tool for 30 seconds.
- Read out the fault memory using the KTM diagnostics tool.
  - » If the error persists:
    - Change the Connectivity Unit.

**Last measure if none of the documented causes leads to elimination of the fault**

- Contact customer service.

## 5.1 Injection valve 1 function



### Functional description

#### Note

**Material damage** Insufficient fuel lubricant has a negative effect on the service life of the injection valve.

- Perform the actuator test only when the throttle valve body is connected to the fuel line.
- 
- The injection valve 1 is supplied with power via terminal 15. After the "**(injection valve 1)**" actuator test is started, the engine control unit switches the injection valve ground signal on/off. An acoustic confirmation signal confirms correct operation.

#### Info

The test ends automatically after 10 seconds.

## 5.2 Injection valve 2 function



### Functional description

#### Note

**Material damage** Insufficient fuel lubricant has a negative effect on the service life of the injection valve.

- Perform the actuator test only when the throttle valve body is connected to the fuel line.
- 
- The injection valve 2 is supplied with power via terminal 15. After the "**(injection valve 2)**" actuator test is started, the engine control unit switches the injection valve ground signal on/off. An acoustic confirmation signal confirms correct operation.

#### Info

The test ends automatically after 10 seconds.

## 5.3 Function of ignition coil

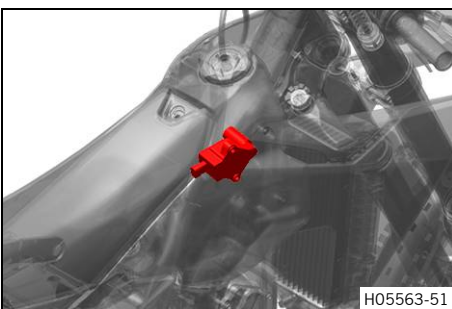

### Functional description



#### Warning

**Risk of injury** The ignition system is under high voltage.

- Do not touch any affected metal parts or the ends of the connection cables during and immediately after the measurement.

- After the actuator test starts, the engine control unit triggers a thyristor in the control unit. In this way, the capacitor can be abruptly discharged. An audible signal or a test spark plug can be used to check the function of the ignition.

#### Info

The test is interrupted by pressing the "**Quit**" button.

## 5.4 Fuel pump operation

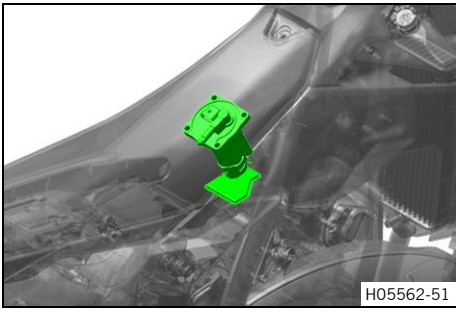

### Functional description

- The engine control unit activates the fuel pump.



### Info

The test can be interrupted by pressing the "Quit" button.

## 5.5 Function of the exhaust control actuator

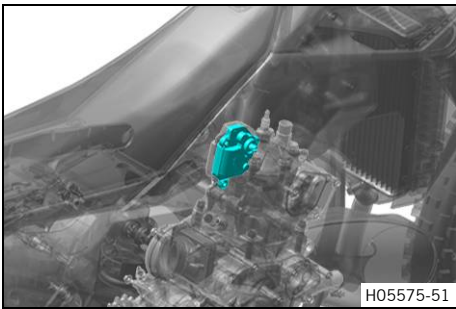

### Functional description

- The exhaust control actuator is supplied with voltage via terminal 15. After the actuator test starts **Exhaust valve**, the engine control unit triggers the exhaust control actuator. An acoustic confirmation signal confirms correct operation.



### Info

The test is interrupted by pressing the "Quit" button.



# 6 WIRING DIAGRAM

6.1 Page 1 of 4

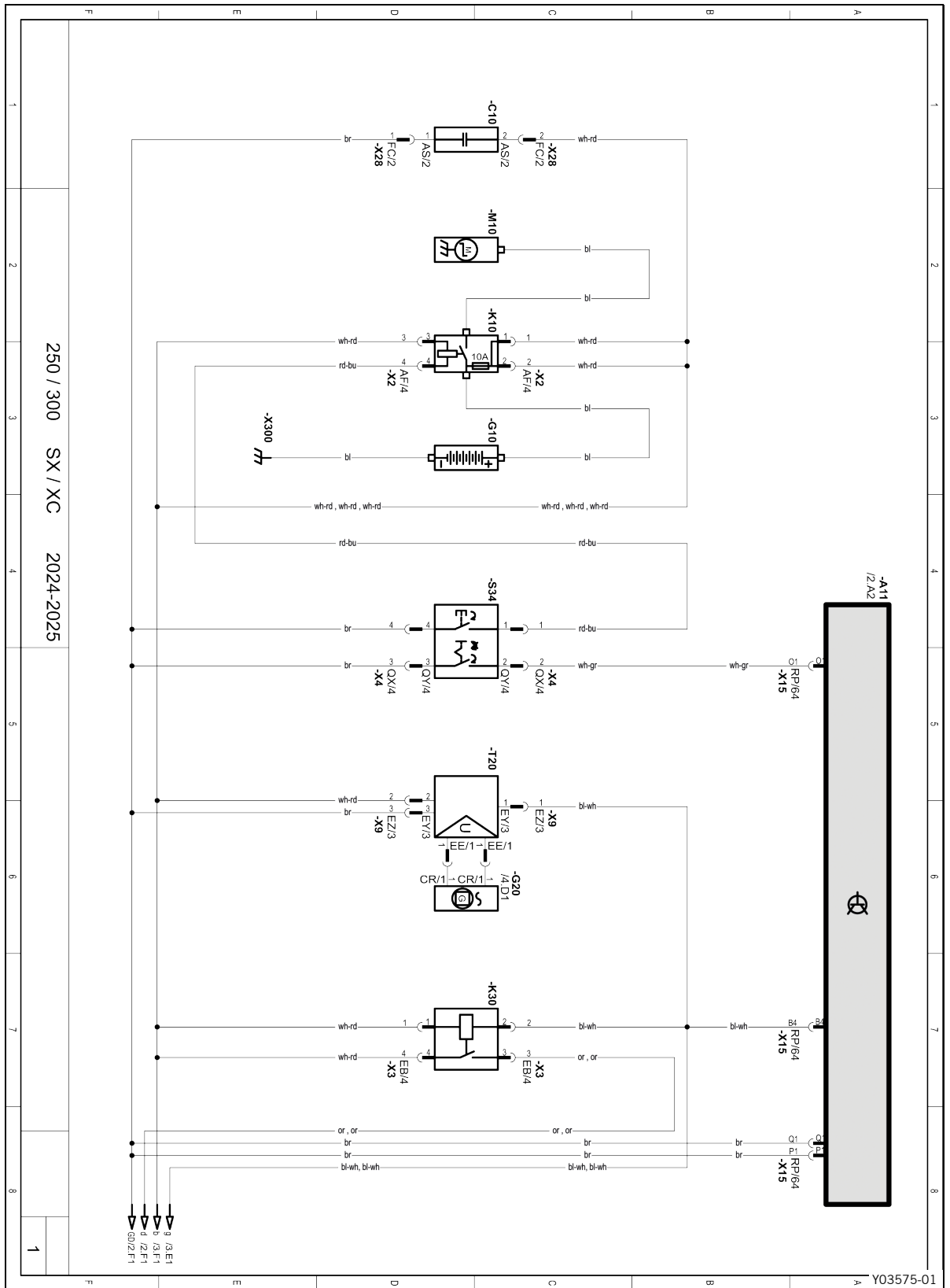

**Components:**

A11	Engine control unit
C10	Capacitor
G10	12-V battery
G20	Alternator
K10	Starter relay with main fuse
K30	Power relay
M10	Starter motor
S34	Combination switch, right
T20	Voltage regulator

# 6 WIRING DIAGRAM

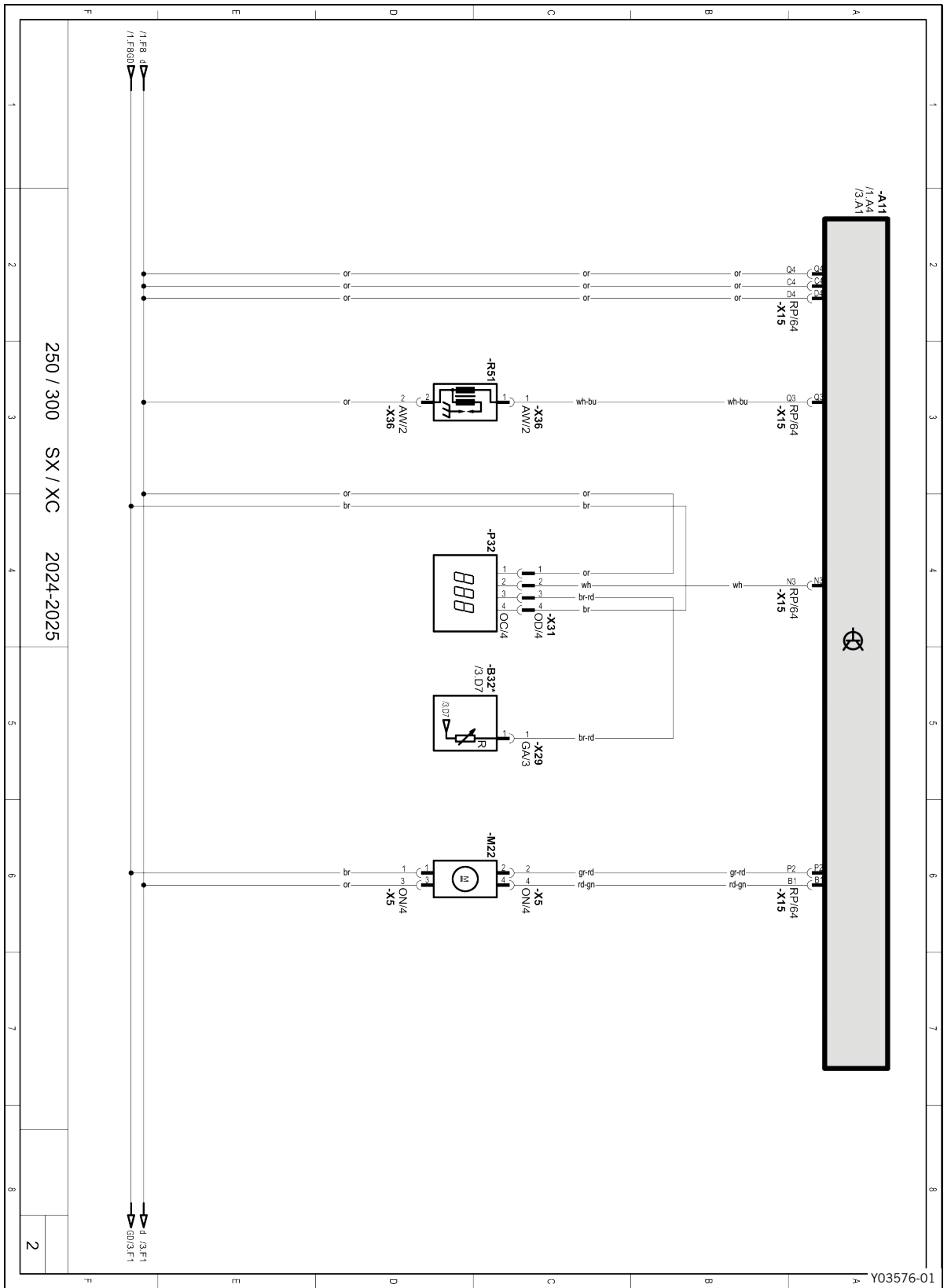

**Components:**

A11	Engine control unit
B32	Fuel level sensor (if installed)
M22	Exhaust control actuator
P32	Service hour counter
R51	Ignition coil

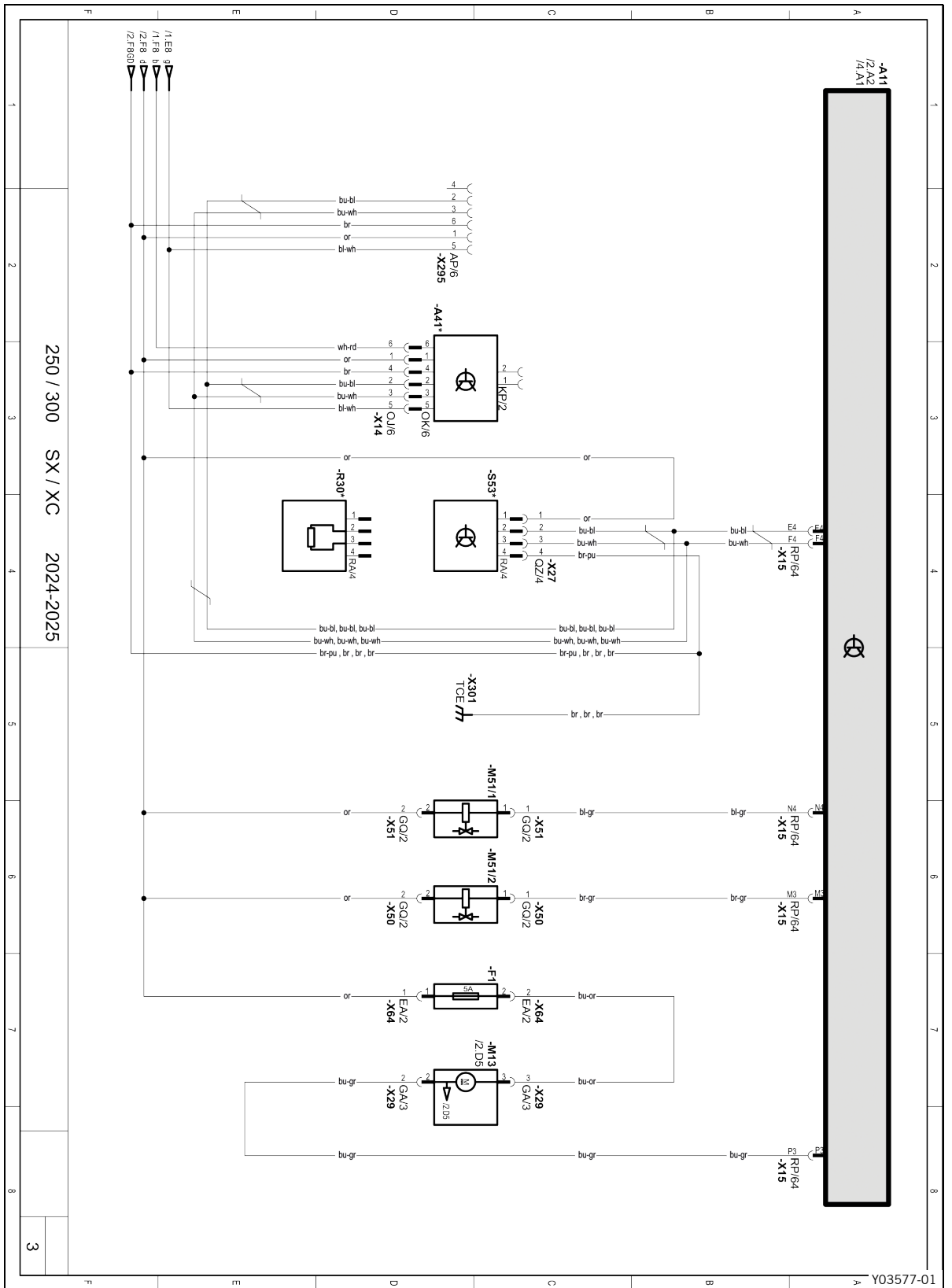

**Components:**

A11	Engine control unit
A41	Connectivity Unit (if installed)
F1	Fuse
M13	Fuel pump
M51/1	Injection valve 1
M51/2	Injection valve 2
R30	Terminating resistor (if installed)
S53	Mapping selector switch (if installed)
X295	Diagnostics connector

# 6 WIRING DIAGRAM

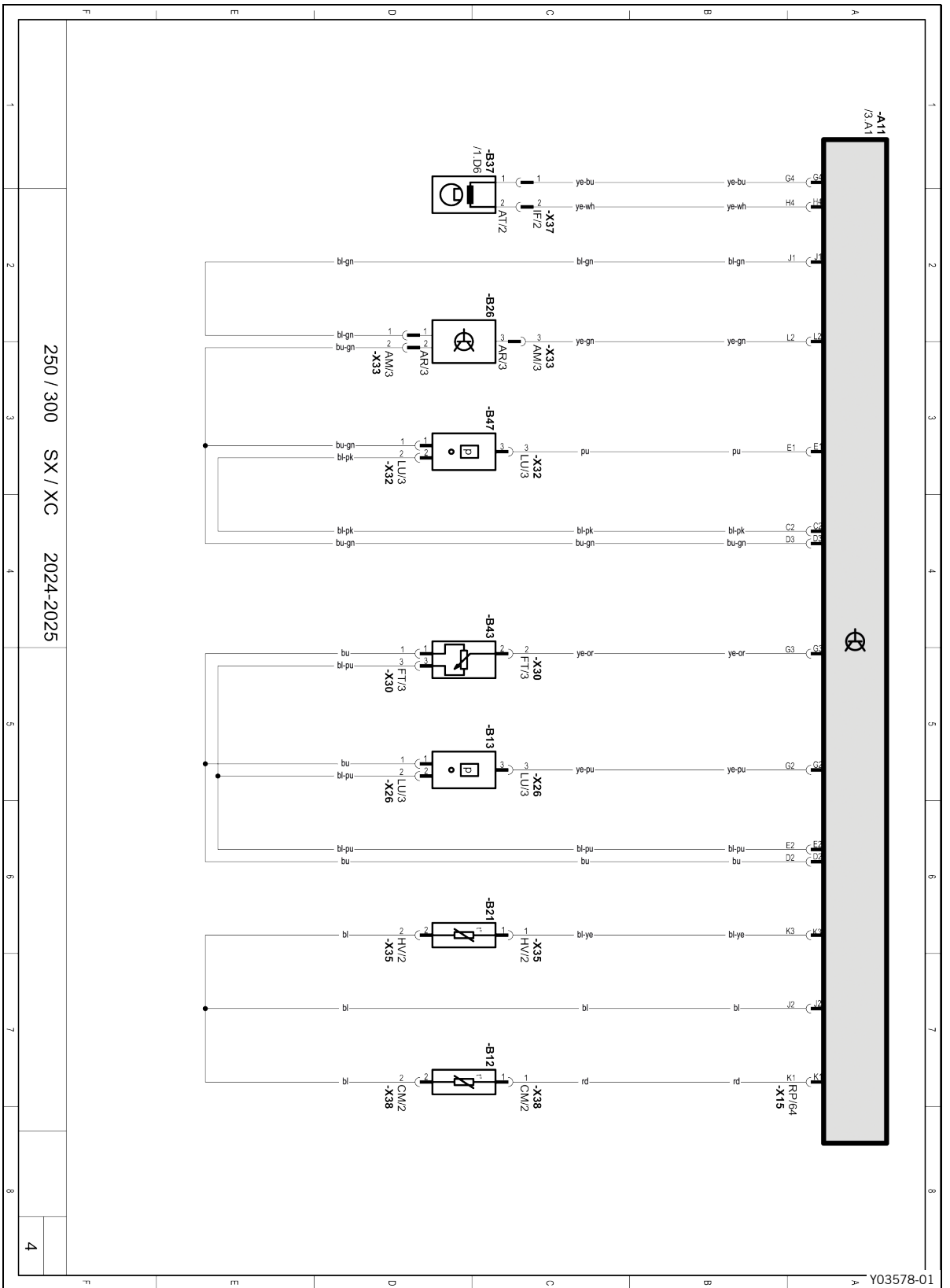

**Components:**

A11	Engine control unit
B12	Intake air temperature sensor
B13	Ambient air pressure sensor
B21	Coolant temperature sensor
B26	Tilt sensor
B37	Crankshaft speed sensor
B43	Throttle valve position sensor
B47	Crank chamber pressure sensor

**Cable colors:**

bl	Black
br	Brown
bu	Blue
gn	Green
gr	Gray
lbu	Light blue
or	Orange
pk	Pink
pu	Violet
rd	Red
wh	White
ye	Yellow

# 7 CONNECTOR OVERVIEW

## 7.1 Tilt sensor connector AM

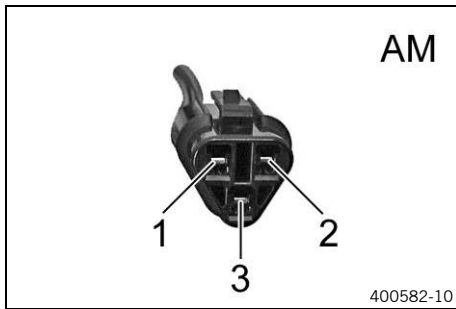

### Pin overview

1	Sensor ground
2	Power supply
3	Signal wire

## 7.2 Diagnostics connector AP

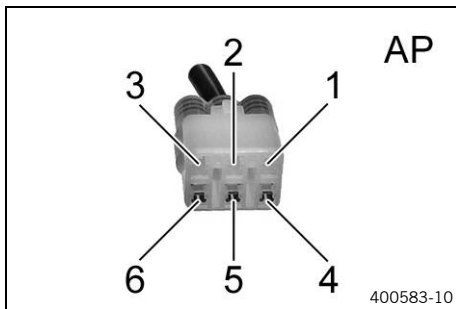

### Pin overview

1	Power supply (terminal 15)
2	CAN high
3	CAN low
4	Not assigned
5	Wired ground
6	Ground

## 7.3 Tilt sensor connector AR

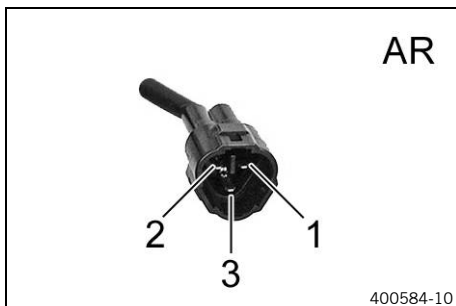

### Pin overview

1	Sensor ground
2	Power supply
3	Signal wire

## 7.4 Capacitor connector AS

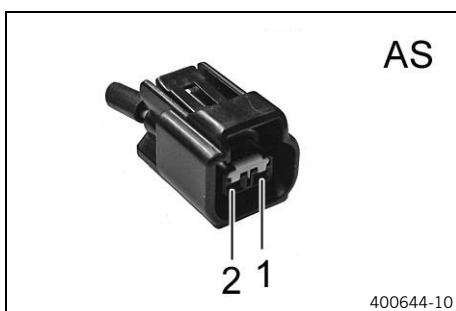

### Pin overview

1	Ground (terminal 31)
2	Power supply (terminal 15)

## 7.5 Crankshaft speed sensor connector AT

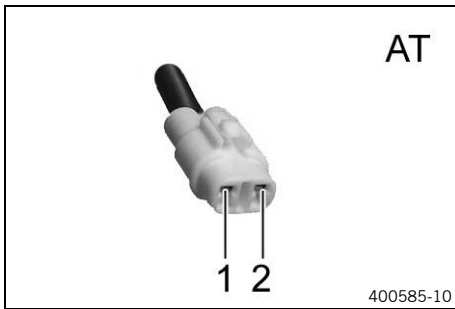

### Pin overview

- |   |             |
|---|-------------|
| 1 | Signal wire |
| 2 | Signal wire |

## 7.6 Ignition coil connector AW

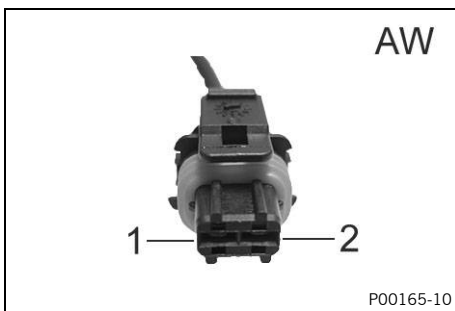

### Pin overview

- |   |              |
|---|--------------|
| 1 | Control wire |
| 2 | Ground       |

## 7.7 Intake air temperature sensor connector CM

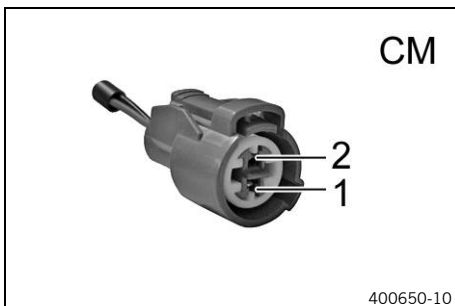

### Pin overview

- |   |               |
|---|---------------|
| 1 | Signal wire   |
| 2 | Sensor ground |

## 7.8 Voltage regulator connector EE

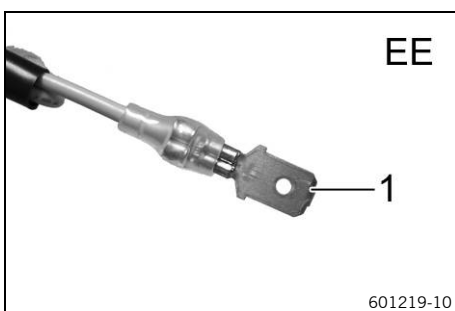

### Pin overview

- |   |             |
|---|-------------|
| 1 | Signal wire |
|---|-------------|

## 7.9 Voltage regulator connector EY

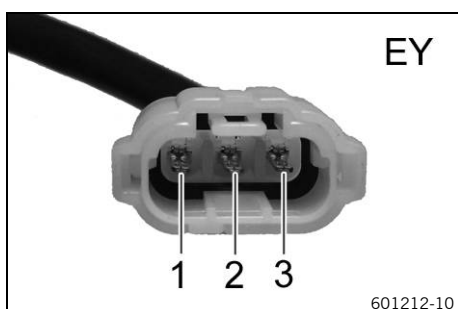

### Pin overview

1	Control wire
2	Power supply (terminal 15)
3	Ground (terminal 31)

## 7.10 Voltage regulator connector EZ

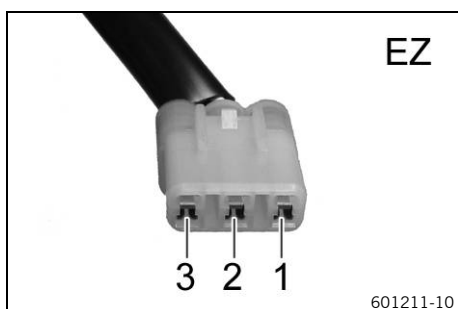

### Pin overview

1	Control wire
2	Power supply (terminal 15)
3	Ground (terminal 31)

## 7.11 Throttle valve position sensor circuit A, connector FT

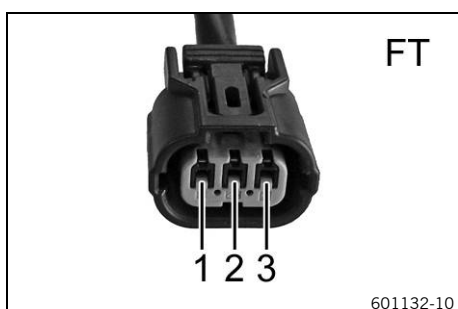

### Pin overview

1	Power supply
2	Signal wire
3	Sensor ground

## 7.12 Fuel pump, connector GA (All SX models)

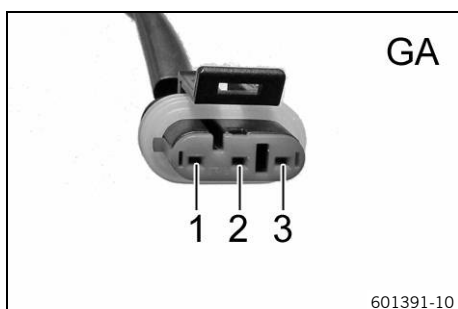

### Pin overview

1	Not assigned
2	Ground (terminal 31)
3	Power supply

## 7.13 Fuel pump, connector GA (All XC models)

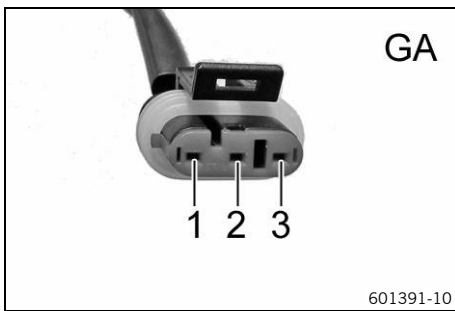

### Pin overview

1	Signal wire, fuel level sensor
2	Ground (terminal 31)
3	Power supply

## 7.14 Injection valve 1, cylinder 1, connector GQ

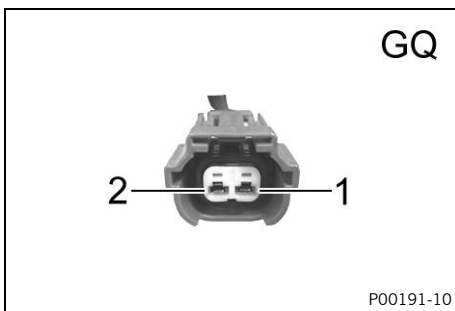

### Pin overview

1	Control wire
2	Power supply (terminal 15)

## 7.15 Injection valve 2, cylinder 1, connector GQ

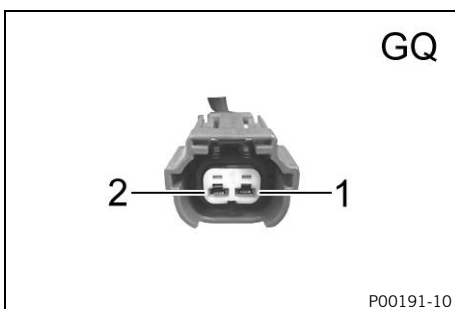

### Pin overview

1	Control wire
2	Power supply (terminal 15)

## 7.16 Coolant temperature sensor connector HV

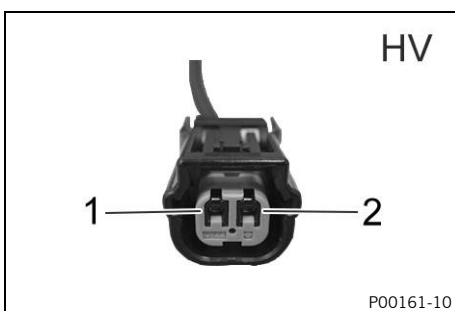

### Pin overview

1	Signal wire
2	Sensor ground

## 7.17 Crankshaft speed sensor connector IF

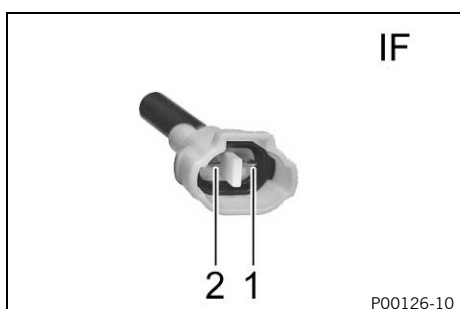

### Pin overview

1	Signal wire
2	Signal wire

## 7.18 Ambient air pressure sensor connector LU

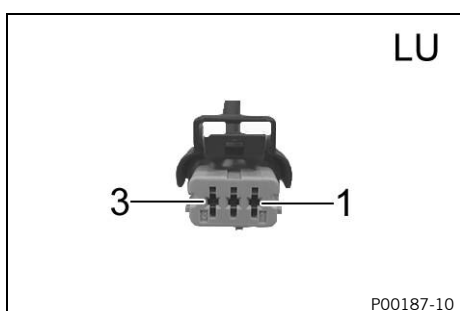

### Pin overview

1	Power supply
2	Ground (terminal 31)
3	Signal wire

## 7.19 Crankcase pressure sensor connector LU

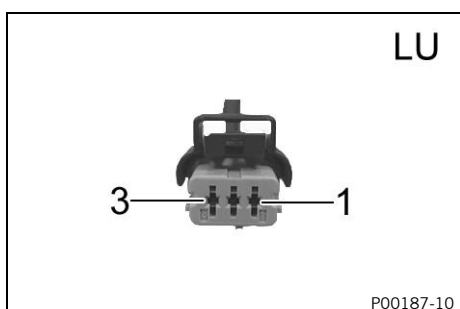

### Pin overview

1	Power supply
2	Ground (terminal 31)
3	Signal wire

## 7.20 Connectivity Unit connector OJ

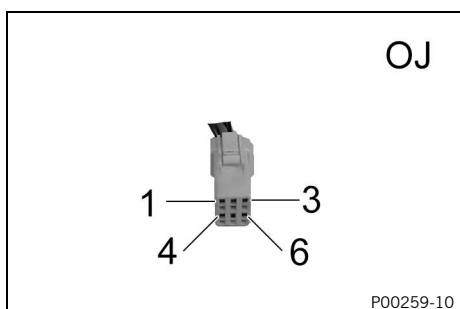

### Pin overview

1	Power supply (terminal 15)
2	CAN high
3	CAN low
4	Ground
5	Ground
6	Power supply (terminal 30)

## 7.21 Exhaust control actuator ON

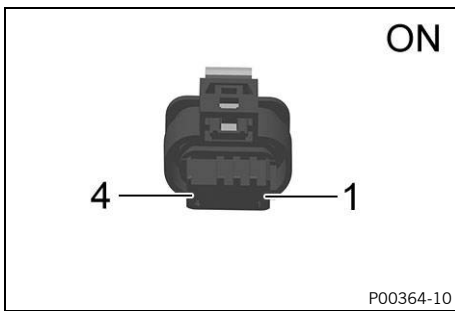

### Pin overview

1	Ground
2	Control wire
3	Power supply
4	Signal wire

## 7.22 Map select switch connector QZ

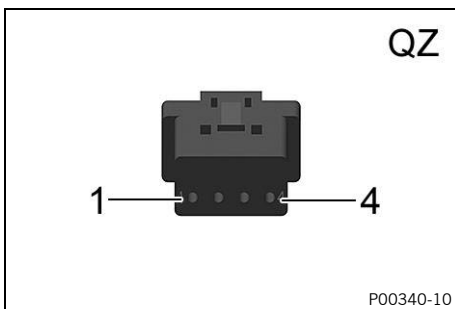

### Pin overview

1	Power supply
2	CAN high
3	CAN low
4	Ground wire

## 7.23 Engine control unit connector RP

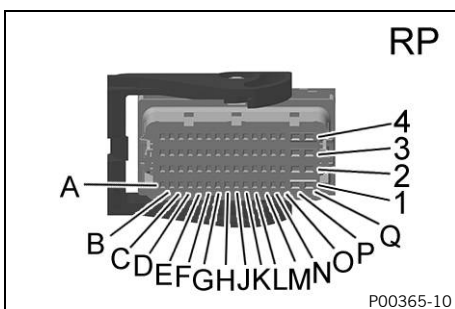

### Pin overview

A1	Not assigned
A2	Not assigned
A3	Not assigned
A4	Not assigned
B1	Signal wire, exhaust control actuator
B2	Not assigned
B3	Not assigned
B4	Control wire, power relay
C1	Not assigned
C2	Ground wire 2
C3	Not assigned
C4	Power supply (terminal 15)
D1	Not assigned
D2	Power supply, sensors 2
D3	Power supply, sensors 1
D4	Power supply (terminal 15)
E1	Signal wire, crankcase pressure sensor
E2	Ground wire 1
E3	Not assigned
E4	CAN high
F1	Not assigned
F2	Not assigned

<b>F3</b>	Not assigned
<b>F4</b>	CAN low
<b>G1</b>	Not assigned
<b>G2</b>	Signal wire, ambient air pressure sensor
<b>G3</b>	Signal wire, throttle valve position sensor circuit A
<b>G4</b>	Crankshaft speed sensor, plus
<b>H1</b>	Not assigned
<b>H2</b>	Not assigned
<b>H3</b>	Not assigned
<b>H4</b>	Crankshaft speed sensor, ground
<b>J1</b>	Ground wire, sensor 4
<b>J2</b>	Ground wire, sensors 3
<b>J3</b>	Not assigned
<b>J4</b>	Not assigned
<b>K1</b>	Signal wire, intake air temperature sensor
<b>K2</b>	Not assigned
<b>K3</b>	Signal wire, coolant temperature sensor
<b>K4</b>	Not assigned
<b>L1</b>	Not assigned
<b>L2</b>	Signal wire, tilting sensor
<b>L3</b>	Not assigned
<b>L4</b>	Not assigned
<b>M1</b>	Not assigned
<b>M2</b>	Not assigned
<b>M3</b>	Control wire, injection valve 2
<b>M4</b>	Not assigned
<b>N1</b>	Not assigned
<b>N2</b>	Not assigned
<b>N3</b>	Control wire, malfunction indicator lamp
<b>N4</b>	Control wire, injection valve 1
<b>O1</b>	Control wire, stop button
<b>O2</b>	Not assigned
<b>O3</b>	Not assigned
<b>O4</b>	Not assigned
<b>P1</b>	Ground (terminal 31)
<b>P2</b>	Control wire, exhaust control actuator
<b>P3</b>	Control wire, fuel pump relay
<b>P4</b>	Not assigned
<b>Q1</b>	Ground (terminal 31)
<b>Q2</b>	Not assigned
<b>Q3</b>	Control wire, ignition coil
<b>Q4</b>	Power supply (terminal 15)

**Cable connector unlocking kit**

Art. no.: 00029014000

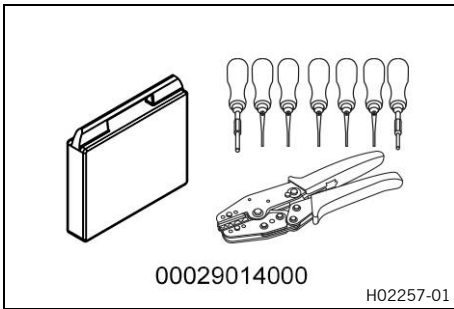

**Diagnostics adapter cable**

Art. no.: 00029094033

**Feature**

Length approx.	25.8 cm (10.16 in)
----------------	--------------------

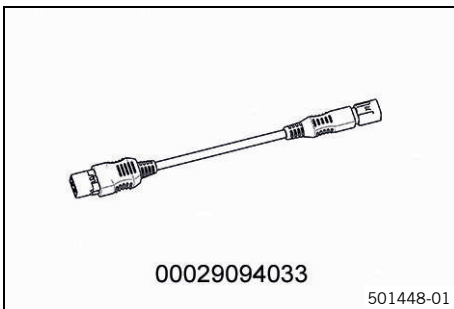

**Break out box**

Art. no.: 00029095001



**Adapter and template VITESCO**

Art. no.: 00029095016

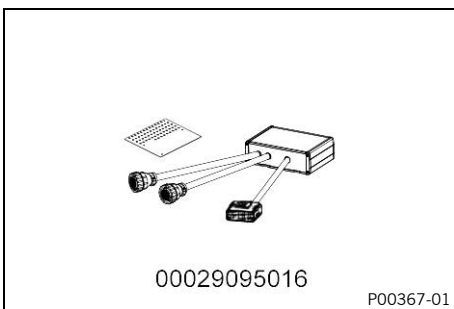

## Diagnostics tablet

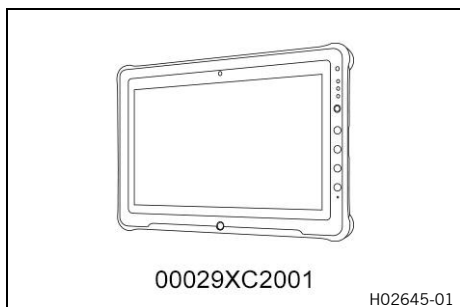

Art. no.: 00029XC2001

## Hand strap

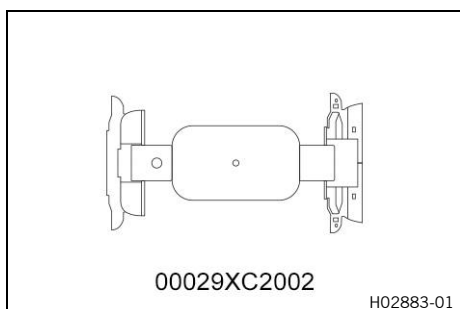

Art. no.: 00029XC2002

## Battery charger

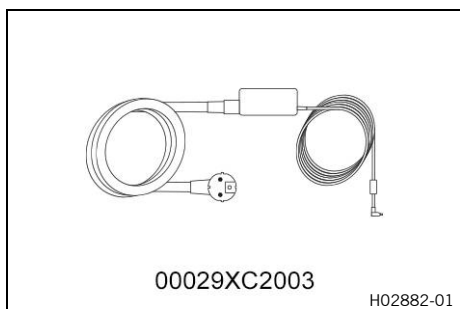

Art. no.: 00029XC2003

## VCI

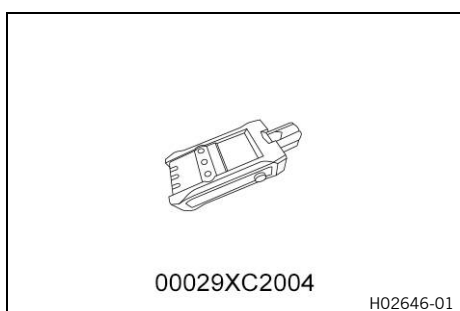

Art. no.: 00029XC2004

**VCI attachment**

Art. no.: 00029XC2005

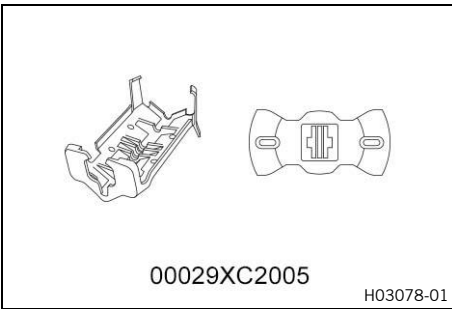

**Protective film**

Art. no.: 00029XC2006



**Diagnostics cable extension**

Art. no.: 00029XC2007

**Feature**

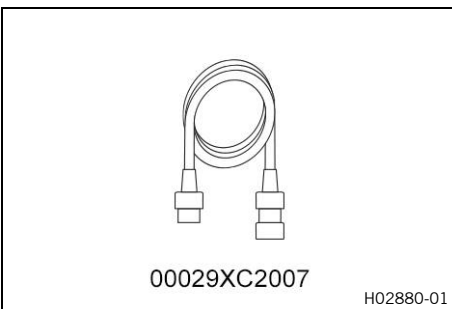

Length approx.	1.15 m (3.77 ft)
----------------	------------------

**USB cable**

Art. no.: 00029XC2008

**Feature**



Length approx.	5 m (16 ft)
----------------	-------------

## 12-V power supply cable

Art. no.: 00029XC2009

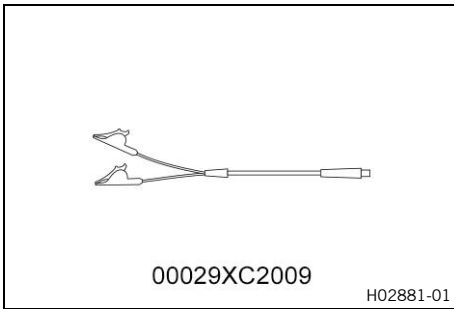

## RideRecorder trigger

Art. no.: 00029XC2010

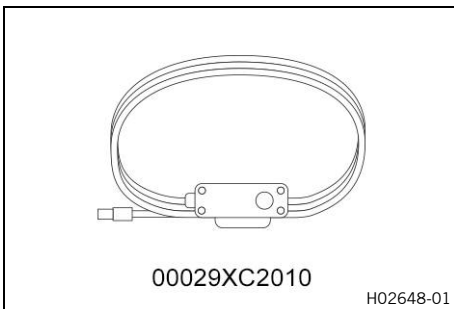

## Case

Art. no.: 00029XC2011



## Docking station

Art. no.: 00029XC2012



**Wall attachment**

Art. no.: 00029XC2013

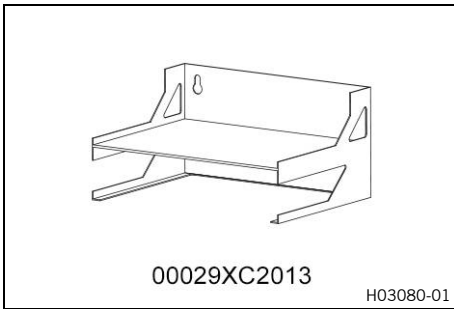

**Battery**

Art. no.: 00029XC2014

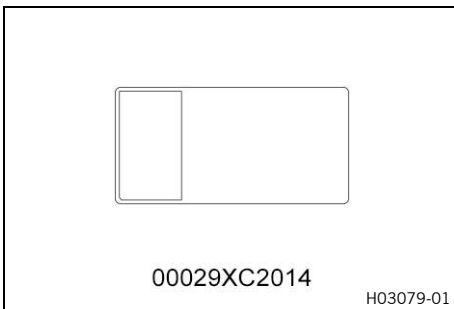

**Input stylus**

Art. no.: 00029XC2015

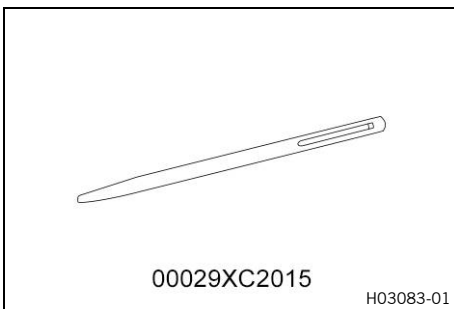

## 9 GLOSSARY OF TECHNICAL TERMS

OBD	On-board diagnosis	Vehicle system, which monitors the specified parameters of the vehicle electronics
-----	--------------------	--

Art. no.	Article number
ca.	circa
cf.	compare
e.g.	for example
etc.	et cetera
i.a.	inter alia
no.	number
poss.	possibly

<b>1</b>	
<b>12-V battery</b>	
starting power	8
<b>A</b>	
<b>Ambient air pressure sensor</b>	15
<b>C</b>	
<b>Capacitor</b>	8
<b>Combination instrument</b>	5
<b>Connectivity Unit</b>	17
<b>Coolant temperature sensor</b>	9
<b>Crankcase pressure sensor</b>	12
<b>Crankshaft speed sensor</b>	10
<b>D</b>	
<b>Diagnostics connector</b>	16
<b>E</b>	
<b>Engine control unit</b>	16
<b>Exhaust control actuator</b>	17
<b>F</b>	
<b>Fuel pump</b>	5-6
<b>I</b>	
<b>Ignition coil</b>	11
<b>Indicator lamps</b>	
overview	5
<b>Injection valves</b>	13
<b>Intake air temperature sensor</b>	12
<b>O</b>	
<b>Overview of indicator lights</b>	5
<b>Overview of relays</b>	7
<b>S</b>	
<b>Starting power of lithium-ion batteries at low temperatures</b>	8
<b>T</b>	
<b>Throttle valve position sensor circuit A</b>	14
<b>Tilt sensor</b>	15
<b>Trouble code</b>	
connectivity Unit	118-140
engine control	18-117
<b>V</b>	
<b>Voltage regulator</b>	7
<b>W</b>	
<b>Wiring diagram</b>	144-151
Page 1 of 4	144
Page 2 of 4	146
page 3 of 4	148
page 4 of 4	150



3240108en

11.06.2024

