

INFODESK 2025

READY 
TO RACE

125 XC-W
150 EXC
150 XC-W

ITEM NO.: 3240165EN



KTM

This manual was written on the basis of the latest information for this model series. We reserve the right to make changes in the interest of technical advancement without at the same time updating this manual.

A description of general workshop instructions will be omitted. Safety rules applicable for day-to-day workshop use are also not mentioned. It is assumed that the work will be performed by a fully trained mechanic.

All specifications are non-binding. KTM Sportmotorcycle GmbH specifically reserves the right to modify or delete technical specifications, prices, colors, forms, materials, services, designs, equipment, etc., without prior notice and without specifying reasons, to adapt these to local conditions, as well as to stop production of a particular model without prior notice. KTM accepts no liability for delivery options, differences from illustrations and descriptions, misprints, and other errors. The models portrayed partly contain special equipment that does not belong to the regular scope of delivery.

© 2025 KTM Sportmotorcycle GmbH, Mattighofen Austria

All rights reserved. Figures: Mitterbauer / Visus Studios / KISKA / KTM

Written permission from the copyright owner is required before any duplication or reproduction.

ISO 9001

KTM applies quality assurance processes that lead to the highest possible product quality as defined in the ISO 9001 international quality management standard.



12 100 6061

Issuing institution:

TÜV SÜD Management Service GmbH

KTM Sportmotorcycle GmbH
Stallhofnerstraße 3
5230 Mattighofen, Austria

This document is valid for:

125 XC-W EU (F7103Y7)

150 EXC EU (F7103Y6)

150 XC-W US (F7175Y3)











1	Means of representation.....	7	3	Engine control trouble code	25
1.1	Conventions.....	7	3.1	Engine control trouble code	25
1.1.1	Icons	7	4	Trouble code, Connectivity Unit	168
1.1.2	Formatting	7	4.1	Trouble code, Connectivity Unit	168
1.1.3	Abbreviations	7	5	Actuator test	191
2	Engine management system components	8	5.1	Injector 1 function	191
2.1	Overview of the engine management system	8	5.1.1	Functional description.....	191
2.2	Fuel pump	9	5.2	Injection valve 2 function	191
2.2.1	Functional description.....	9	5.2.1	Functional description.....	191
2.3	Vehicle system control unit	10	5.3	Function of ignition coil	192
2.4	Voltage regulator	10	5.3.1	Functional description.....	192
2.5	12 V battery	10	5.4	Fuel pump operation	192
2.6	Overview of indicator lights (EXC)	11	5.4.1	Functional description.....	192
2.7	Overview of indicator lights (All XC-W models)	11	5.5	Radiator fan function	193
2.8	Combination switch (125 XC-W)	12	5.5.1	Functional description.....	193
2.9	Lambda sensor heater	12	6	Wiring diagram	194
2.9.1	Functional description.....	13	6.1	Page 1 (All EU models)	194
2.10	Oxygen sensor	13	6.2	Page 2 (All EU models)	196
2.10.1	Functional description.....	13	6.3	Page 3 (All EU models)	198
2.11	Coolant temperature sensor	14	6.4	Page 4 (All EU models)	200
2.11.1	Functional description.....	14	6.5	Page 5 (All EU models)	202
2.12	Crankshaft position sensor	15	6.6	Page 1 (All XC-W models)	204
2.12.1	Functional description.....	16	6.7	Page 2 (All XC-W models)	206
2.13	Ignition coil	16	6.8	Page 3 (All XC-W models)	208
2.14	Dwell	17	6.9	Page 4 (All XC-W models)	210
2.14.1	Functional description.....	17	7	Connector overview	212
2.15	Ignition point	17	7.1	Diagnostics connector AP	212
2.15.1	Functional description.....	17	7.2	Tilt sensor connector AM	212
2.16	Oil pump	17	7.3	Tilt sensor connector AR	212
2.16.1	Functional description.....	18	7.4	Crankshaft speed sensor connector AT	212
2.17	Oil level sensor	18	7.5	Ignition coil connector AW	213
2.18	Crankcase pressure sensor	18	7.6	Intake air temperature sensor connector CM	213
2.18.1	Functional description.....	18	7.7	Fuel vapor valve connector DF	213
2.19	Purge valve	19	7.8	Lambda sensor connector DY	213
2.20	Diagnostic connector	19	7.9	Voltage regulator connector EY	214
2.21	Intake air temperature sensor	19	7.10	Voltage regulator connector FA	214
2.22	Injection valves, cylinder 1	20	7.11	Throttle valve position sensor circuit A, connector FT	214
2.22.1	Functional description.....	21	7.12	Fuel pump, connector GA	214
2.23	Circuit A throttle valve position sensor	21	7.13	Oil pump connector GR	215
2.23.1	Functional description.....	21	7.14	Injector 1, cylinder 1, socket connector GQ	215
2.24	Ambient air pressure sensor	22	7.15	Injection valve 2, cylinder 1, connector GQ	215
2.24.1	Functional description.....	22	7.16	Coolant temperature sensor connector HV	215
2.25	Idle speed adjustment screw	22			
2.26	Tilt sensor	23			
2.26.1	Functional description.....	23			
2.27	Engine control unit	23			
2.28	Exhaust control actuator	24			
2.29	Connectivity Unit	24			

7.17	Crankshaft speed sensor connector IF	216
7.18	Lambda sensor connector IM	216
7.19	Vehicle system control unit connector LL	216
7.20	Oil lamp connector LT	217
7.21	Crankcase pressure sensor connector LU	217
7.22	Ambient air pressure sensor connector LU	217
7.23	Connectivity Unit connector OJ	217
7.24	Exhaust control actuator socket connector ON	218
7.25	Oil level sensor connector PZ	218
7.26	Map select switch connector QZ	218
7.27	Engine control unit connector RP	218
	Notes	221
A	Tools	221
	A.1 Tool overview	221
B	Technical terms	225
	Index	226

1.1 Conventions

1.1.1 Icons

-  Indicates a desired result (e.g. of a work step or a function).
-  Indicates an undesired result (e.g. of a work step or a function).
-  All work marked with this symbol requires specialist knowledge and technical understanding. Ensure that this work is carried out or supervised by trained personnel from an authorized KTM workshop, and that any special tools required are used.
-  Indicates a page reference.
-  Indicates information with more details.
-  Indicates a tip, e.g. to simplify work.
-  Indicates the result from a test step.
-  Indicates the end of an activity, including any rework.

1.1.2 Formatting

Proprietary name	Indicates a proprietary name.
Name[®]	Indicates a protected name.
Brand[™]	Indicates a brand available on the open market.
<u>Underlined terms</u>	Refer to technical details of the vehicle or indicate technical terms that are explained in the glossary.

1.1.3 Abbreviations

2-pc.	two-part
Part no.	Part number
or	respectively
approx.	circa
etc.	et cetera
poss.	possibly/possible
if necessary	if necessary
cmpl.	complete
min.	at least
no.	number
no fig.	no figure
s.	see
among others	among others/not limited to
and the like	and the like
etc.	et cetera
cf.	compare
e.g.	for example

2 Engine management system components

2.1 Overview of the engine management system

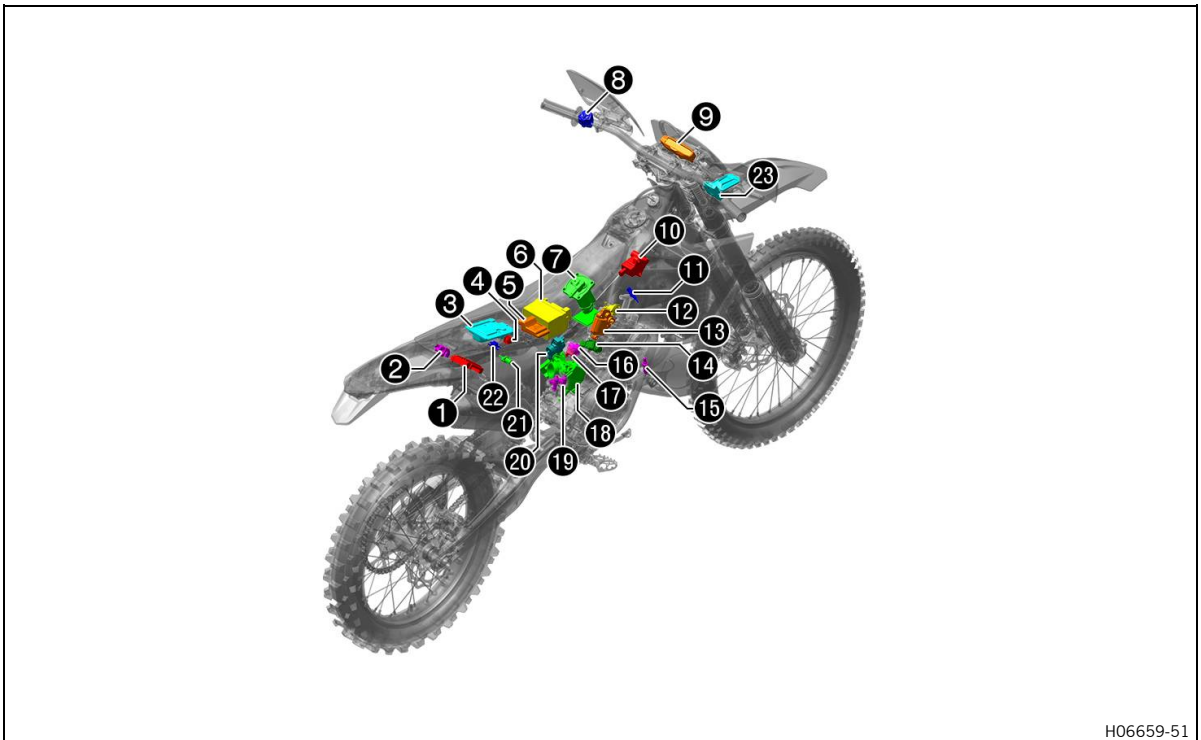

H06659-51

- | | | | |
|---|--|-----|--|
| ❶ | Voltage regulator 📖 (p. 10) | ❶❶ | Coolant temperature sensor 📖 (p. 14) |
| ❷ | Ambient air pressure sensor 📖 (p. 22) | ❶❷ | Oil level sensor 📖 (p. 18) |
| ❸ | Engine control unit 📖 (p. 23) | ❶❸ | Exhaust control actuator 📖 (p. 24) |
| ❹ | Diagnostic connector 📖 (p. 19) | ❶❹ | Crankcase pressure sensor 📖 (p. 18) |
| ❺ | Vehicle system control unit 📖 (p. 10) | ❶❺ | Oxygen sensor 📖 (p. 13) |
| ❻ | 12 V battery 📖 (p. 10) | ❶❻ | Oil pump 📖 (p. 17) |
| ❼ | Fuel pump 📖 (p. 9) | ❶❼ | Crankshaft position sensor 📖 (p. 15) |
| ❽ | (125 XC-W) | ❶❽ | Circuit A throttle valve position sensor 📖 (p. 21) |
| | Combination switch 📖 (p. 12) | ❶❾ | Injection valves, cylinder 1 📖 (p. 20) |
| ❾ | (EXC) | ❶❷❶ | Purge valve 📖 (p. 19) |
| | Overview of indicator lights 📖 (p. 11) | ❶❷❷ | Intake air temperature sensor 📖 (p. 19) |
| ❾ | (All XC-W models) | ❶❷❸ | Tilt sensor 📖 (p. 23) |
| | Overview of indicator lights 📖 (p. 11) | ❶❷❹ | Connectivity Unit 📖 (p. 24) |
| ❿ | Ignition coil 📖 (p. 16) | | |

2.2 Fuel pump



Installation location

- The fuel pump is located inside the fuel tank.

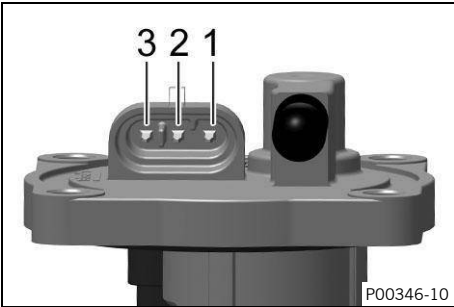

Pin overview

- | | |
|---|--------------------------------|
| 1 | Signal wire, fuel level sensor |
| 2 | Control wire |
| 3 | Voltage supply |

2.2.1 Functional description

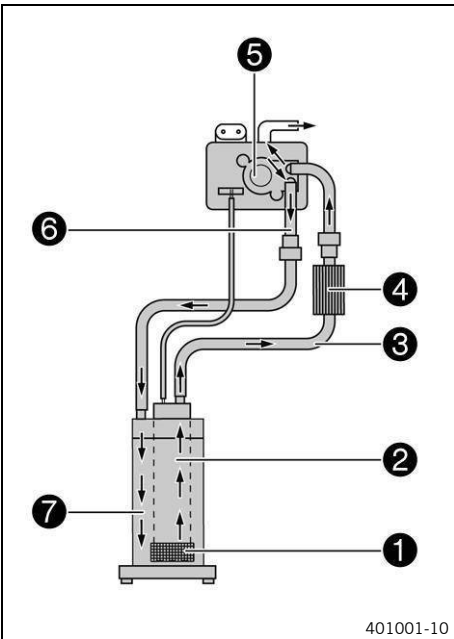

- The fuel passes through the fuel screen **1** before entering the electrically driven vane pump **2**. This delivers the fuel via the fuel line **3** and the fuel filter **4** and on into the pressure regulator **5**. The pressure regulator ensures an even fuel pressure under all load conditions. Excess fuel flows back via hose **6** into pump housing **7**.

Fuel pressure	
When the fuel pump is active	3.3 bar ... 3.7 bar (47.9 psi ... 53.7 psi)

2 Engine management system components

2.3 Vehicle system control unit

The vehicle system control unit **1** is located under the seat.

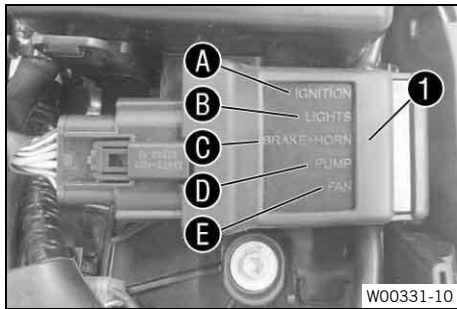

The vehicle system control unit replaces the electronic fuses and relays.

All outputs are switched independently of the signals of the voltage regulator and ECU.

The outputs are deactivated individually in the event of overcurrent.

This enables easy error detection because the status of each output is indicated via LED lights.

The vehicle system control unit monitors the electronics system completely independently.

As soon as an indicated error is rectified, the status light of the vehicle system control unit changes from red to green.

overview  (p. 10)

overview

A	Ignition
B	Light
C	Brake light + horn
D	Fuel pump
E	Radiator fan

2.4 Voltage regulator

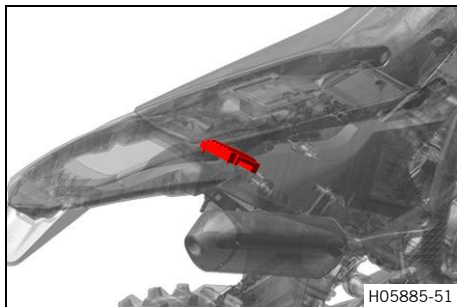

Installation location

- The voltage regulator is located behind the left-hand side cover.

Voltage regulator connector **EY**  (p. 214) Pin assignment

Voltage regulator connector **FA**  (p. 214) Pin assignment



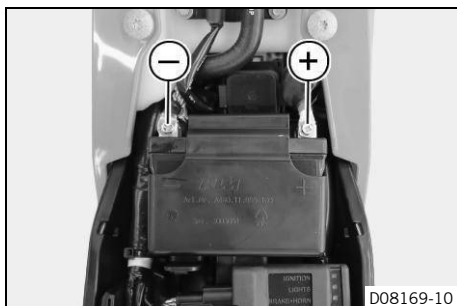

2.5 12 V battery



Battery voltage «VBAT»	9.6 V ... 15.4 V
------------------------	------------------





2.6 Overview of indicator lights (EXC)



Condition		Meaning
	The high beam indicator lamp lights up blue	The high beam is switched on.
	Malfunction indicator lamp lights up/flashes yellow	The OBD has detected a malfunction in the vehicle electronics. Come safely to a halt, and contact an authorized KTM workshop.
	The fuel level warning lamp lights up yellow	The fuel level has reached the reserve mark.
	Turn signal indicator lamp flashes green	The turn signal is switched on.
	The oil level warning lamp lights up red	Oil level has reached the MIN marking. Ride for no more than until the remaining fuel in the tank is depleted and at the next opportunity refuel with 2-stroke oil.

2.7 Overview of indicator lights (All XC-W models)



Condition		Meaning
	The high beam indicator lamp lights up blue	The high beam is switched on.
	Malfunction indicator lamp lights up/flashes yellow	The OBD has detected a malfunction in the vehicle electronics. Come safely to a halt, and contact an authorized KTM workshop.
	The fuel level warning lamp lights up yellow	The fuel level has reached the reserve mark.
	The oil level warning lamp lights up red	Oil level has reached the MIN marking. Ride for no more than until the remaining fuel in the tank is depleted and at the next opportunity refuel with 2-stroke oil.

2 Engine management system components

2.8 Combination switch (125 XC-W)

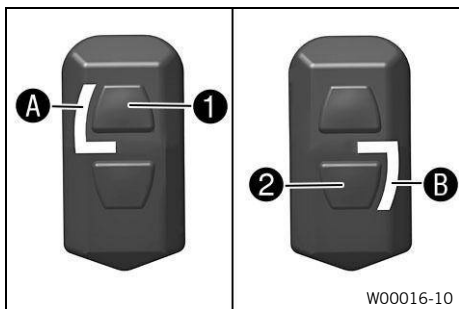

The combination switch is fitted on the left side of the handlebar. The engine characteristic can be changed using button ① and button ② on the combination switch.

Condition	Meaning
STANDARD ①	STANDARD mapping is activated when indicator light A lights up.
ADVANCED ②	ADVANCED mapping is activated when the indicator light B illuminates.



Note

If no combination switch is installed, the last selected mapping is activated.
If a combination switch has never been mounted, the **STANDARD** mapping is activated.

2.9 Lambda sensor heater

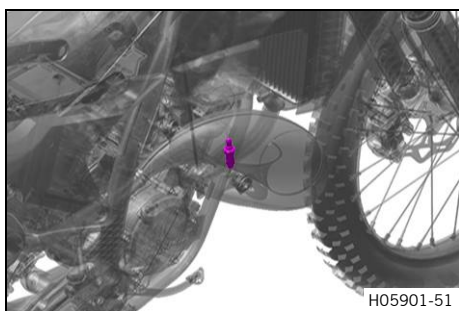

Installation location

- The lambda sensor heater is integrated into the lambda sensor, which is installed on the manifold.

Component description

- The lambda sensor is heated from the inside by a ceramic heating element so that the temperature of the lambda sensor is kept constant regardless of the exhaust gas temperature. The connections of the heating element are completely isolated from the sensor signal voltage.

Lambda sensor connector **DY**  (p. 213) Pin assignment

2.9.1 Functional description

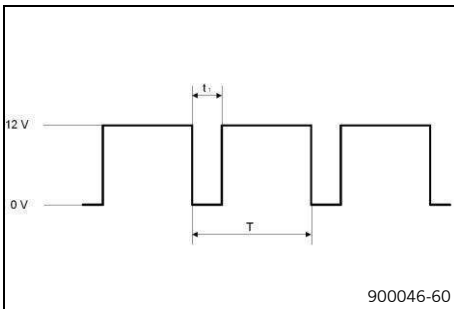

- The lambda sensor heater is supplied with battery voltage by the power relay. After the engine is started, the engine control unit grounds the lambda sensor heater. In order to control the lambda sensor heater, the signal control is modulated. The lambda sensor heater is controlled at a modulation frequency T of 100 Hz. The smaller the duty cycle t_1 is set for the control, the greater is the effective power supply of the lambda sensor heater.

Lambda sensor heater	
Resistance at: 20 °C (68.0 °F)	6.9 Ω ... 8.5 Ω

2.10 Oxygen sensor

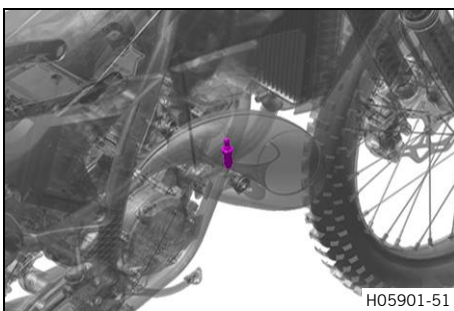

Installation location

- The lambda sensor is mounted in the manifold.

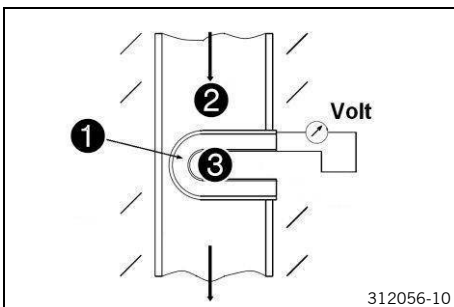

Component description

- In principle, the lambda sensor consists of a ceramic body **1** that is coated with a platinum layer on each side. The platinum layer functions as an electrode. The outer layer is in contact with the exhaust gas **2** and the inner layer is in contact with the ambient air **3**. The ceramic component becomes conductive above a certain temperature and a voltage is generated when the oxygen content of the ambient air and the exhaust gas differs. The greater the difference in oxygen content, the greater the voltage.

Lambda sensor connector **DY**  (p. 213) Pin assignment

2.10.1 Functional description

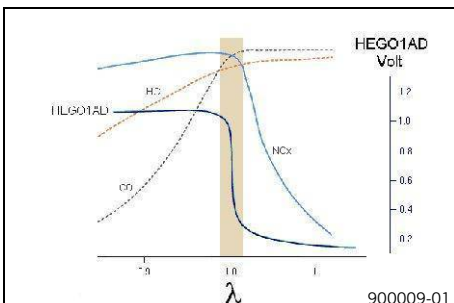

- All lambda (O_2) sensors are open to the atmosphere, which contains approximately 21 percent oxygen (O_2). The exhaust gas of a gasoline engine contains up to 2 percent oxygen. The sensor output voltage is dependent on the oxygen content in the exhaust gas stream. When the exhaust gas contains just 2 percent oxygen, the engine is running "lean" and the sensor generates a low voltage. When the exhaust gas contains almost 0 percent oxygen, the engine is running "rich" and the sensor generates a high voltage.

2 Engine management system components

Oxygen sensor	
Voltage range within the closed loop range «HEG01AD»	0.2 V ... 0.8 V

2.11 Coolant temperature sensor

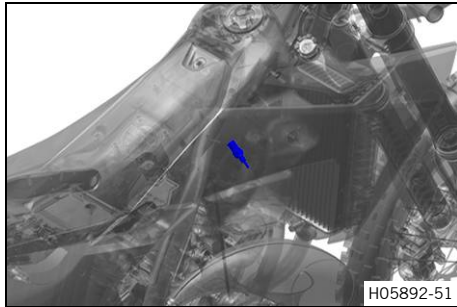

Installation location

- The coolant temperature sensor is at the top of the cylinder head in the radiator hose.

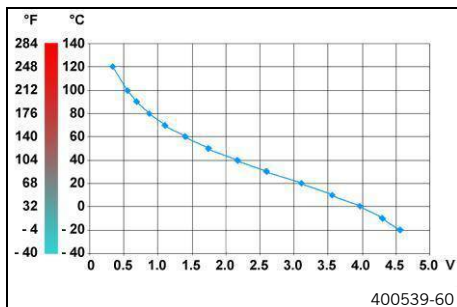

Component description

- The coolant temperature sensor is an NTC resistor. In NTC resistors, the resistance decreases with increasing temperature; however, the "nil" value is never reached. When the temperature decreases, the resistance increases; however, the "infinite" value is never reached.

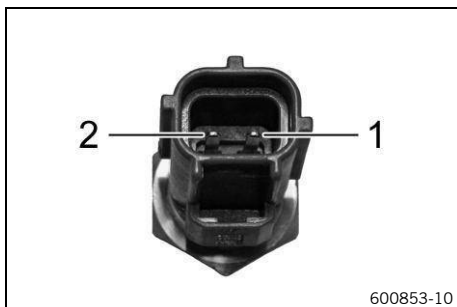

Pin overview

1	Signal wire
2	Sensor ground

2.11.1 Functional description

- The temperature sensor is used for the engine control.

Coolant temperature sensor	
Resistance at: -20 °C (-4.0 °F)	13.50 kΩ ... 16.50 kΩ
Voltage at: -20 °C (-4.0 °F)	4.5 V
Resistance at: -10 °C (14.0 °F)	8.24 kΩ ... 10.08 kΩ
Voltage at: -10 °C (14.0 °F)	4.3 V
Resistance at: 0 °C (32.0 °F)	5.17 kΩ ... 6.31 kΩ
Voltage at: 0 °C (32.0 °F)	3.9 V
Resistance at: 10 °C (50.0 °F)	3.33 kΩ ... 4.07 kΩ
Voltage at: 10 °C (50.0 °F)	3.5 V
Resistance at: 20 °C (68.0 °F)	2.21 kΩ ... 2.70 kΩ
Voltage at: 20 °C (68.0 °F)	3.1 V

Resistance at: 30 °C (86.0 °F)	1.49 kΩ ... 1.83 kΩ
Voltage at: 30 °C (86.0 °F)	2.5 V
Resistance at: 40 °C (104.0 °F)	1.04 kΩ ... 1.27 kΩ
Voltage at: 40 °C (104.0 °F)	2.1 V
Resistance at: 50 °C (122.0 °F)	730 Ω ... 892 Ω
Voltage at: 50 °C (122.0 °F)	1.7 V
Resistance at: 60 °C (140.0 °F)	526 Ω ... 642 Ω
Voltage at: 60 °C (140.0 °F)	1.4 V
Resistance at: 70 °C (158.0 °F)	385 Ω ... 471 Ω
Voltage at: 70 °C (158.0 °F)	1.0 V
Resistance at: 80 °C (176.0 °F)	286 Ω ... 350 Ω
Voltage at: 80 °C (176.0 °F)	0.86 V
Resistance at: 90 °C (194.0 °F)	216 Ω ... 264 Ω
Voltage at: 90 °C (194.0 °F)	0.68 V
Resistance at: 100 °C (212.0 °F)	165 Ω ... 202 Ω
Voltage at: 100 °C (212.0 °F)	0.6 V
Resistance at: 110 °C (230.0 °F)	128 Ω ... 156 Ω
Voltage at: 110 °C (230.0 °F)	0.44 V
Resistance at: 120 °C (248.0 °F)	100 Ω ... 122 Ω
Voltage at: 120 °C (248.0 °F)	0.34 V

2.12 Crankshaft position sensor

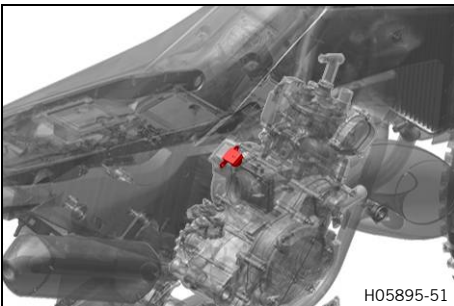

Installation location

- The crankshaft speed sensor is located on the left side of the engine below the alternator cover.

Component description

- The crankshaft speed sensor consists of a permanent magnet and an induction coil with a soft iron core. The counter piece to the crankshaft speed sensor is the sensor wheel whose 22 teeth are equidistant except in one place where one tooth is wider. The sensor wheel is attached to the alternator rotor. The rotor is connected to the crankshaft. There is a small air gap between the crankshaft speed sensor and the sensor wheel.

Crankshaft speed sensor connector **AT**  (p. 212) Pin assignment

2 Engine management system components

2.12.1 Functional description

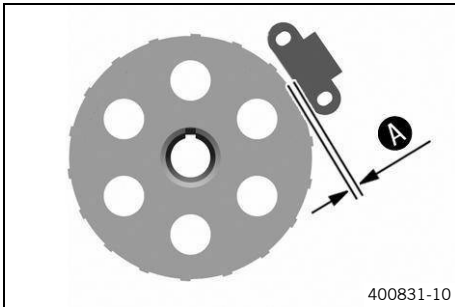

- The magnetic flux through the induction coil depends on whether a gap or a tooth is opposite to the crankshaft speed sensor. A tooth bundles the magnetic leakage flux of the permanent magnet while a gap weakens it. When the rotor and thus the sensor wheel turns, a magnetic field change is caused by each tooth. The change in the magnetic field generates an alternating voltage in the induction coil. The number of pulses per time unit are a measure of the rotating speed of the rotor. The wider tooth on the sensor wheel allows the engine control unit to detect the current position of the crankshaft.

Crankshafts - rotational speed sensor/rotor - distance	0.70 mm (0.0276 in)
--	------------------------

Crankshaft position sensor	
Resistance at: 20 °C (68.0 °F)	108 Ω ... 132 Ω
Voltage at starting engine speed	2 V ... 4 V
Note AC voltage	

2.13 Ignition coil

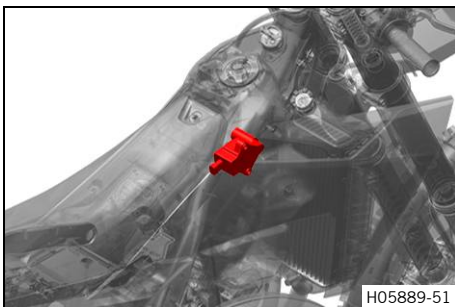

Installation location

- The ignition coil is located above the cylinder head in the frame.

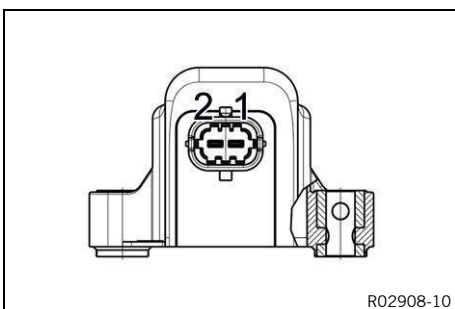

Pin overview

1 (-) Ground

2 (+) Control wire

Ignition coil	
Primary winding resistance at: 20 °C (68.0 °F)	0.337 Ω ... 0.412 Ω

2.14 Dwell

2.14.1 Functional description

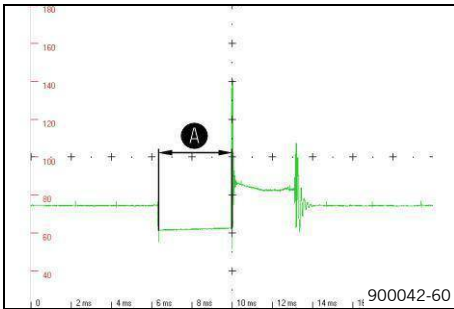

- The dwell angle **A** is the number of crankshaft degrees that the primary circuit is closed and the magnetic field builds up. The time is stated for which the primary circuit is closed.

2.15 Ignition point

2.15.1 Functional description

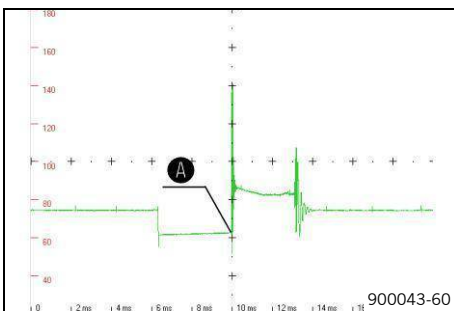

- The ignition point **A** is set relative to TDC and is expressed as a crankshaft angle. The spark is generated by interrupting the primary circuit.

2.16 Oil pump

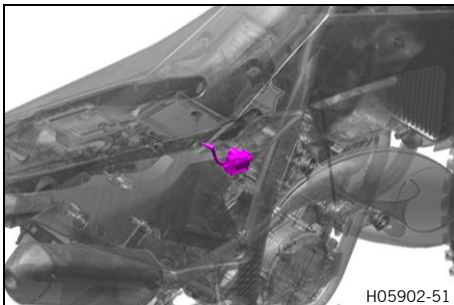

Installation location

- The oil pump is located above the throttle valve body.

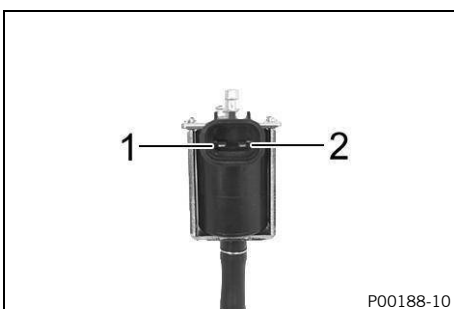

Pin overview

- | | |
|---|----------------|
| 1 | Voltage supply |
| 2 | Control wire |

2 Engine management system components

2.16.1 Functional description

- The oil pump is controlled depending on the throttle valve position sensor and the crankcase pressure sensor so that the required oil capacity is available for all riding and load conditions.

Oil pump	
Resistance at: 20 °C (68.0 °F)	11.2 Ω ... 13.6 Ω

2.17 Oil level sensor



Installation location

- The oil level sensor is mounted on the oil tank.

Functional description

- When the oil level reaches the minimum mark, a signal is transmitted to the engine control unit.

Oil level sensor connector **PZ**  (p. 218) Pin assignment

2.18 Crankcase pressure sensor

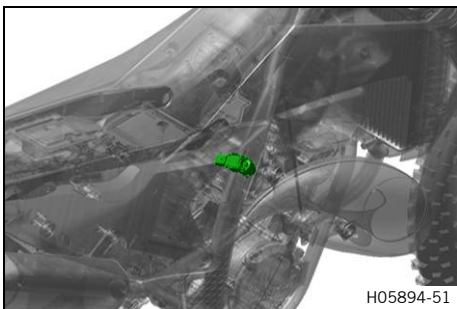

Installation location

- The crankcase pressure sensor is located above the throttle valve body.

Component description

- Electronics and a measuring cell can be found in the housing of the crank chamber pressure sensor. In the measuring cell a diaphragm encloses a reference pressure chamber. When the shape of the diaphragm is altered by external pressure, the conductivity of the measuring resistors, and thus the measured voltage, is altered. The measured voltage is processed by the electronic system and forwarded to the engine control unit.

2.18.1 Functional description

- The output voltage of the crankcase pressure sensor depends on the crankcase pressure and is output via the signal wire.

2.19 Purge valve

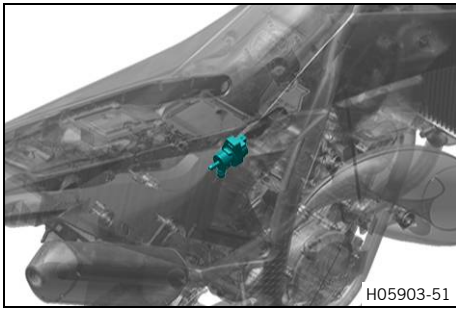

Installation location

- The fuel vapor valve is located on the left next to the throttle valve body.

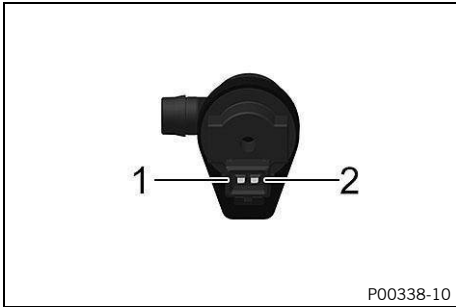

Pin overview

1	Control wire
2	Ground

Purge valve	
at: 20 °C (68.0 °F)	24.2 Ω ... 27.8 Ω

2.20 Diagnostic connector

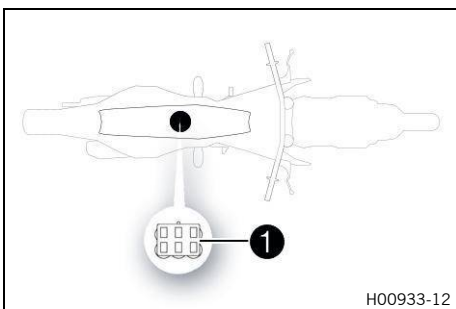

Diagnostics connector ① is located under the seat with the engine control unit.

2.21 Intake air temperature sensor

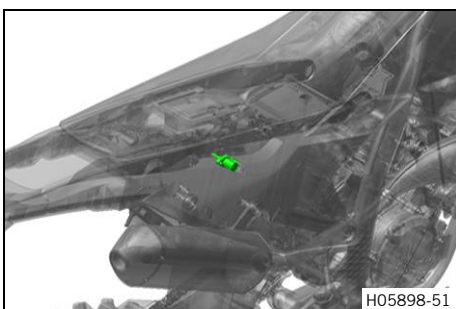

Installation location

- The intake air temperature sensor is located on the air filter box.

2 Engine management system components

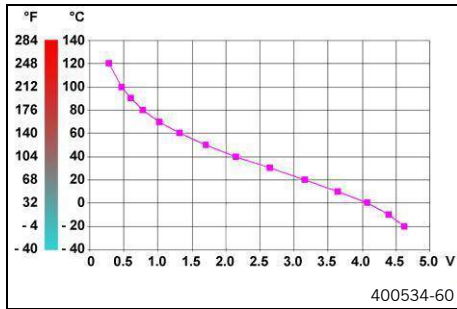

Component description

- The intake air temperature sensor is an NTC resistor. In NTC resistors, the resistance decreases with increasing temperature; however, the "nil" value is never reached. When the temperature decreases, the resistance increases; however, the "infinite" value is never reached.

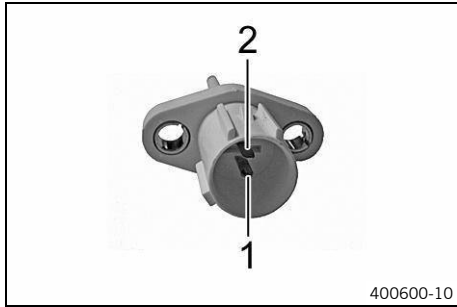

Pin overview

1	Sensor ground
2	Signal wire

Intake air temperature sensor	
Resistance at: -20 °C (-4.0 °F)	18.80 kΩ
Voltage at: -20 °C (-4.0 °F)	4.67 V
Resistance at: 20 °C (68.0 °F)	2.942 kΩ
Voltage at: 20 °C (68.0 °F)	3.14 V
Resistance at: 40 °C (104.0 °F)	1.136 kΩ
Voltage at: 40 °C (104.0 °F)	2.15 V
Resistance at: 100 °C (212.0 °F)	0.1553 kΩ
Voltage at: 100 °C (212.0 °F)	0.46 V

2.22 Injection valves, cylinder 1

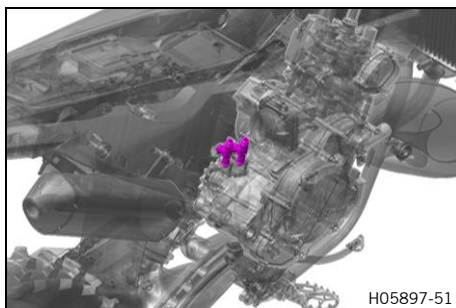

Installation location

- Both injection valves are located on the throttle valve body.
 - Injection valve 1 is located at the front of the throttle valve body in the direction of travel.
 - Injection valve 2 is located at the rear of the throttle valve body in the direction of travel.

Component description

- The injection valve consists of a solenoid, a spring-loaded plunger, a needle valve, and a filter. When current flows through the coil in the solenoid, a magnetic field is generated which attracts the plunger, overcoming the spring force; this lifts the needle valve off its seat. Fuel is discharged through eight injection holes and forms two conical jets. When the current is switched off, the magnetic field collapses and the spring closes the needle valve. The filter keeps any contamination out of the holes.

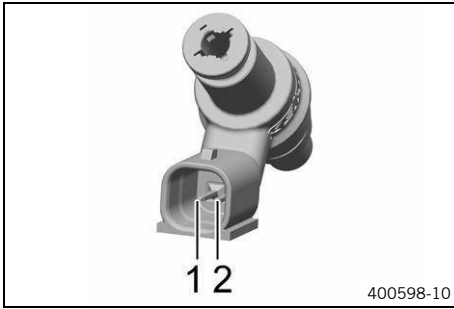

Pin overview

1	Control wire
2	Voltage supply

2.22.1 Functional description

- The injection valve is supplied with power via terminal 15. The engine control unit calculates the injection rate required and grounds the injection valve via the amplification stage in the engine control unit. The longer the injection valve is connected to ground, the greater the fuel quantity injected.

Injector	
Resistance at: 20 °C (68.0 °F)	11.4 Ω ... 12.6 Ω

2.23 Circuit A throttle valve position sensor

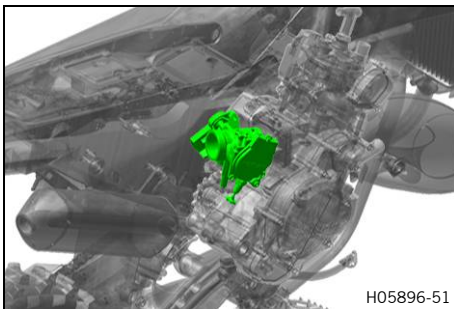

Installation location

- Throttle valve position sensor circuit A is located on the left side of the throttle valve body.

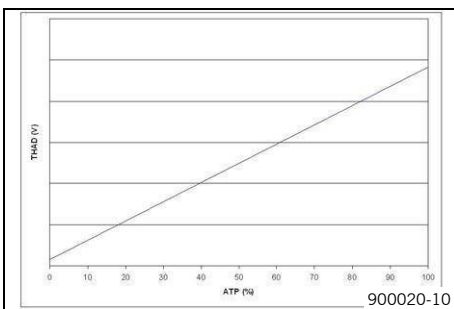

Component description

- The throttle valve position sensor circuit A has a linear characteristic line and operates as a potentiometer.

Throttle valve position sensor circuit A, connector FT (p. 214) Pin assignment

2.23.1 Functional description

- The output voltage of the throttle valve position sensor is dependent on the opening angle of the throttle valve and is sent via the signal wire to determine the throttle valve position.

Circuit A throttle valve position sensor	0.42 V ... 4.6 V
Circuit A throttle valve position sensor	1.5° ... 84.5° (0.026 rad ... 1.475 rad)

2 Engine management system components

2.24 Ambient air pressure sensor

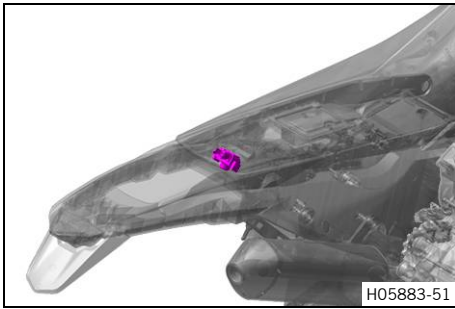

Installation location

- The ambient air pressure sensor is located on the left under the side cover.

Component description

- The electronics and a measuring cell are located in the housing of the ambient air pressure sensor. In the measuring cell a diaphragm encloses a reference pressure chamber. When the shape of the diaphragm is altered by external pressure, the conductivity of the measuring resistors, and thus the measured voltage, is altered. The measured voltage is processed by the electronic system and forwarded to the engine control unit.

2.24.1 Functional description

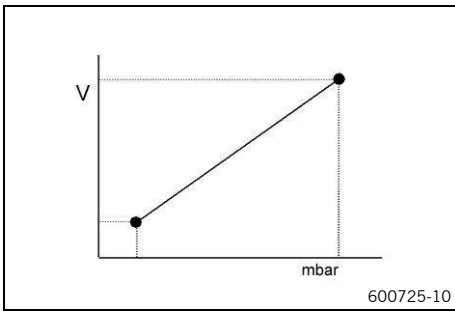

- The output voltage of the ambient air pressure sensor is adjusted depending on the ambient air pressure and is sent via the signal wire. The voltage signal rises when the ambient air pressure increases.

Ambient air pressure sensor voltage	
at: 133 mbar (1.93 psi)	1 V
at: 957 mbar (13.88 psi)	2.3 V
at: 2,500 mbar (36.26 psi)	4.75 V

2.25 Idle speed adjustment screw

The idle setting of the throttle body substantially influences the vehicle's starting behavior, a stable idle speed, and the vehicle's response when the throttle is opened.

An engine with a correctly set idle speed is easier to start than an engine with the idle speed set incorrectly.

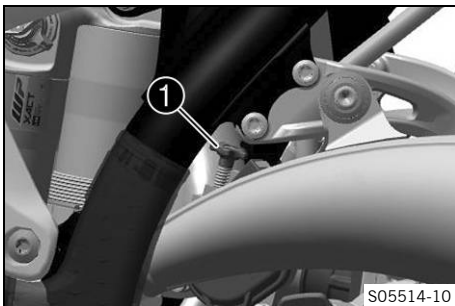

The idle speed is adjusted using idle speed adjusting screw ①.

i Note

If the idle speed is high, the engine is slow to run, the engine brake is low and the throttle response is aggressive, the adjusting screw must be turned counterclockwise.

If the idle speed is low, the engine is running fast, the engine brake is high and the throttle response is not clean, the adjusting screw must be turned clockwise.

For optimum performance, it is recommended to adjust the idle speed using the dedicated functions in the diagnostics tool.

2.26 Tilt sensor

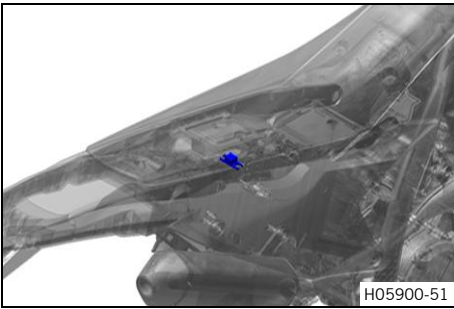

Installation location

- The tilt sensor is located under the seat.

Component description

- The sensor functions on the basis of the Hall effect. The tilt sensor contains a pendulum with a magnet. The pendulum passes over a Hall sensor. The electronics of the tilt sensor evaluate the Hall voltage and activate the signal voltage.

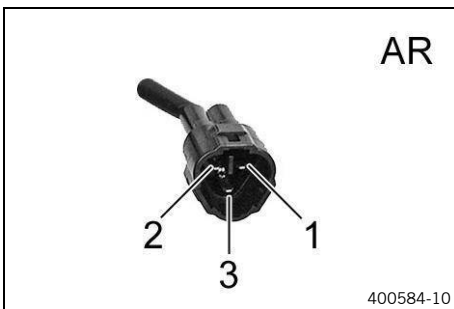

Pin overview

1	Sensor ground
2	Voltage supply
3	Signal wire

2.26.1 Functional description

- The tilt sensor is connected in series to a measuring resistor on the voltage side and ground side, both of which are in the engine control unit. Depending on the vehicle inclination, the electronic system of the tilt sensor switches the signal voltage either toward the voltage or toward the ground using a resistor. The engine control unit detects the inclination of the vehicle on the basis of the voltage value of the signal wire.

Tilt sensor	
Voltage «No fall»	0.4 V ... 1.4 V
Voltage «Fall»	3.7 V ... 4.6 V

2.27 Engine control unit

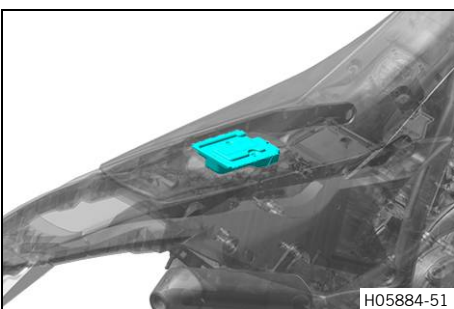

Installation location

- The engine control unit is located under the seat.

2 Engine management system components

i Note

When an engine control unit from the parts center is initially programmed, it is given an identity. That means that when writing to the engine control unit, e.g., using the flash file KMA430EUxxxxxx (150 EXC series), the engine control unit is defined as an A430 version and can from this point only be used on the A430 model range (specifically installed control unit).

After completing programming, the vehicle identification number must be entered into the engine control unit using the «Coding» function.

The blink codes are only displayed by the derestricted version of the vehicle.

Engine control unit connector **RP**  (p. 218) Pin assignment

2.28 Exhaust control actuator

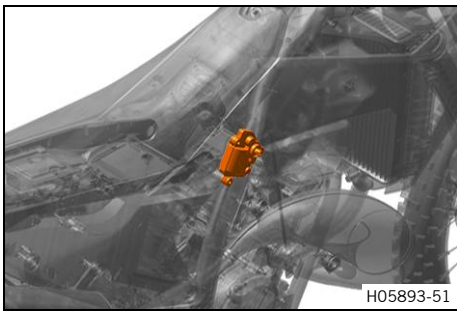

Installation location

- The exhaust control actuator is located on the left side of the cylinder head.

Component description

- The exhaust control actuator optimizes performance. Settings are made via an actuator. Depending on engine speed, the control flap is altered via the exhaust control actuator. The engine control unit controls the exhaust control actuator.

Exhaust control actuator socket connector **ON**  (p. 218) Pin assignment

2.29 Connectivity Unit

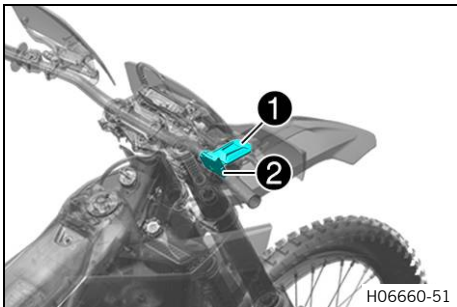

Installation location

- The Connectivity Unit is located behind the headlight mask.

Setup







- The Connectivity Unit consists of the antenna **1** and the control unit **2**.

Component description

- The Connectivity Unit is equipped with a bluetooth module to which a smartphone can be connected, thereby offering a range of functions and setting options.

Connectivity Unit connector **OJ**  (p. 217) Pin assignment

3.1 Engine control trouble code

Blink code for malfunction indicator light	 45: Malfunction indicator light flashes 4x long, 5x short
Display on diagnostic tool	P003111 «Lambda sensor heater» «Short circuit to ground»
Error level condition	Oxygen sensor heater - short circuit to ground Time: ≥ 1 s
Possible cause	Lambda sensor heater – the value is not plausible  (p. 25)
	Lambda sensor heater – the power supply is faulty  (p. 25)
	Lambda sensor heater – the control wire is faulty  (p. 26)
	Lambda sensor heater – the control wire has a short circuit to sensor ground  (p. 27)
	Lambda sensor heater – the control wire has a short circuit to ground  (p. 27)
Last action	– Contact customer service.

Lambda sensor heater – the value is not plausible

Condition

- + Oxygen sensor is disconnected  (p. 13)
- Lambda sensor heater – check resistance.

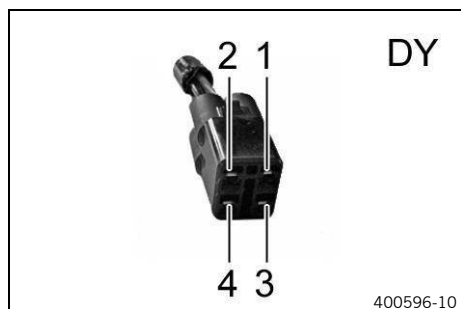



Resistance measurement points
Lambda sensor connector **DY** Pin **3** – Lambda sensor connector **DY** Pin **4**

Lambda sensor heater	6.9 Ω ... 8.5 Ω
----------------------	-----------------

- » Specification does not match set value
 - Change the lambda sensor.
- » If the specifications have been met:
 - Check the next possible cause
Lambda sensor heater – the power supply is faulty

Lambda sensor heater – the power supply is faulty

Condition

- + Diagnostic tool is connected and active
- + Engine control unit is connected  (p. 23)
- + Oxygen sensor is disconnected  (p. 13)
- Lambda sensor heater – check the power supply.

3 Engine control trouble code

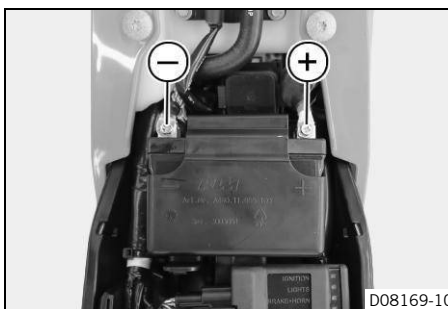
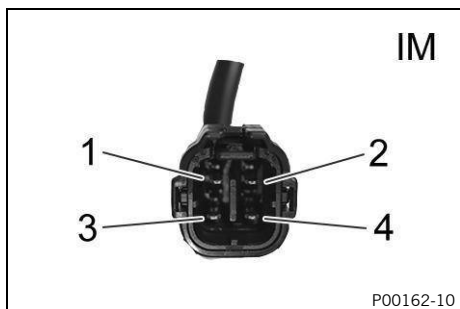

V Voltage measurement points
 Lambda sensor connector **IM** Pin **3** – Measuring point **Ground (-)**

The value must not deviate from the battery voltage «**VBAT**» by more than 1 V.

i **Note**
 For the measurement, the measuring points must be subjected to a 12 V/21 W bulb.

- » Specification does not match set value
 - Check Lambda sensor connector **IM** (p. 216) pin **3**.
 - Check wire from Lambda sensor connector **IM** (p. 216) pin **3** to the next node in the wiring harness.
- » If the specifications have been met:
 - Check the next possible cause
 Lambda sensor heater – the control wire is faulty

Lambda sensor heater – the control wire is faulty

Condition

- + Diagnostic tool is disconnected
- + Engine control unit is disconnected (p. 23)
- + The breakout box is connected to the engine control unit main wiring harness with adapter **00029095016**
- + Oxygen sensor is disconnected (p. 13)
- Lambda sensor heater – check the control wire.

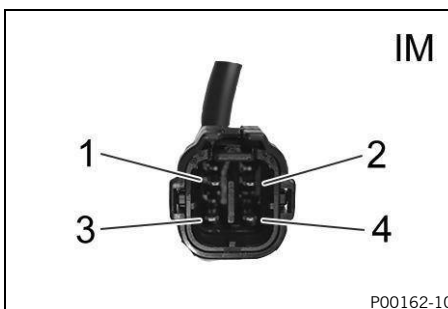
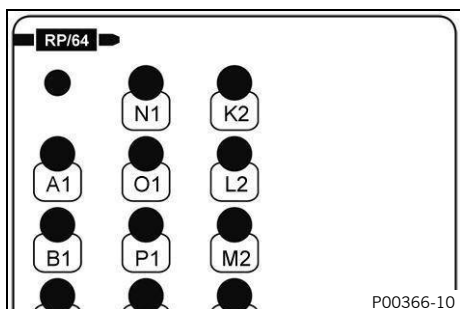

Ω Resistance measurement points
 Bob box connector **RP** Pin **M4** – Lambda sensor connector **IM** Pin **4**



Resistance ≤ 0.6 Ω

- » Specification does not match set value
 - Check Engine control unit connector **RP** (p. 218) pin **M4** and Lambda sensor connector **IM** (p. 216) pin **4**.
 - Check wire from Engine control unit connector **RP** (p. 218) pin **M4** to Lambda sensor connector **IM** (p. 216) pin **4**.

- » If the specifications have been met:
 - Check the next possible cause
 - Lambda sensor heater – the control wire has a short circuit to sensor ground

Lambda sensor heater – the control wire has a short circuit to sensor ground

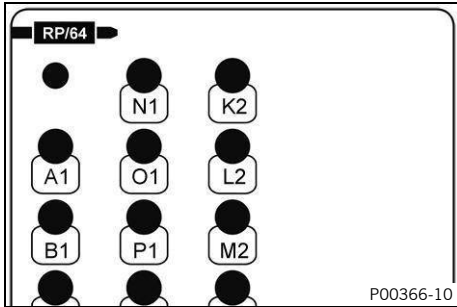

Condition

- + Diagnostic tool is disconnected
- + Engine control unit is disconnected  (p. 23)
- + The breakout box is connected to the engine control unit main wiring harness with adapter **00029095016**
- + Oxygen sensor is disconnected  (p. 13)
- Lambda sensor heater – check the control wire for a short circuit to sensor ground.





Ω Resistance measurement points
Bob box connector **RP** Pin **M4** – Bob box connector **RP** Pin **E2**

Resistance	$\infty \Omega$
------------	-----------------

- » Specification does not match set value
 - Check wire from Engine control unit connector **RP**  (p. 218) pin **M4** to Lambda sensor connector **IM**  (p. 216) pin **4** for a short circuit to sensor ground.
- » If the specifications have been met:
 - Check the next possible cause
 - Lambda sensor heater – the control wire has a short circuit to ground

Lambda sensor heater – the control wire has a short circuit to ground

Condition

- + Diagnostic tool is disconnected
- + Engine control unit is disconnected  (p. 23)
- + The breakout box is connected to the engine control unit main wiring harness with adapter **00029095016**
- + Oxygen sensor is disconnected  (p. 13)
- Lambda sensor heater – check the control wire for a short circuit to ground (terminal 31).

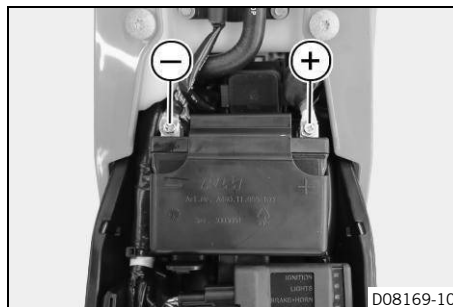
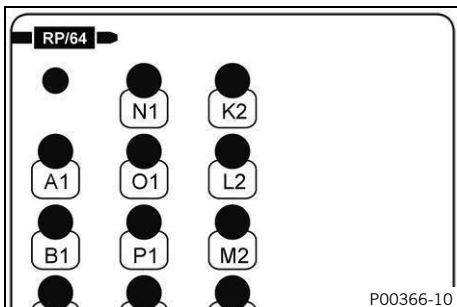



Ω Resistance measurement points
Bob box connector **RP** Pin **M4** – Measuring point **Ground (-)**

Resistance	$\infty \Omega$
------------	-----------------





- » Specification does not match set value

3 Engine control trouble code

- Check wire from Engine control unit connector **RP**  (p. 218) pin **M4** to Lambda sensor connector **IM**  (p. 216) pin **4** for short circuit to ground.

Last action

- Contact customer service.

Blink code for malfunction indicator light	 45: Malfunction indicator light flashes 4x long, 5x short
Display on diagnostic tool	P003212 «Lambda sensor heater» «Short circuit to plus»
Error level condition	Oxygen sensor heater - short circuit to plus Time: ≥ 1 s
Possible cause	Lambda sensor heater – the value is not plausible  (p. 29)
	Lambda sensor heater – the control wire has a short circuit to plus (terminal 30)  (p. 29)
	Lambda sensor heater – the control wire has a short circuit to ignition plus (terminal 15)  (p. 30)
Last action	– Contact customer service.

Lambda sensor heater – the value is not plausible

Condition

- + Oxygen sensor is disconnected  (p. 13)
- Lambda sensor heater – check resistance.

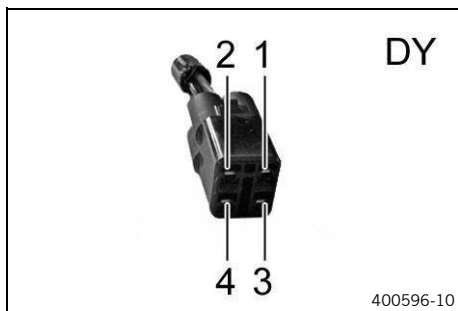



 Resistance measurement points
Lambda sensor connector **DY** Pin **3** – Lambda sensor connector **DY** Pin **4**

Lambda sensor heater	6.9 Ω ... 8.5 Ω
----------------------	-----------------

- » Specification does not match set value
 - Change the lambda sensor.
- » If the specifications have been met:
 - Check the next possible cause
Lambda sensor heater – the control wire has a short circuit to plus (terminal 30)

Lambda sensor heater – the control wire has a short circuit to plus (terminal 30)

Condition

- + Diagnostic tool is disconnected
- + Engine control unit is disconnected  (p. 23)
- + The breakout box is connected to the engine control unit main wiring harness with adapter **00029095016**
- + Oxygen sensor is disconnected  (p. 13)
- Lambda sensor heater – check the control wire for a short circuit to plus (terminal 30).

3 Engine control trouble code

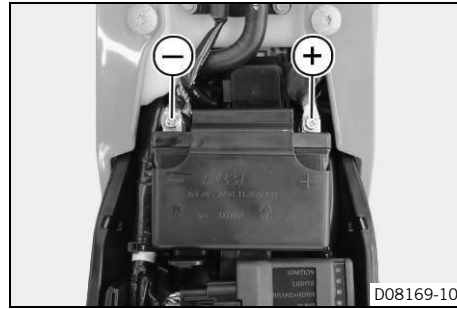
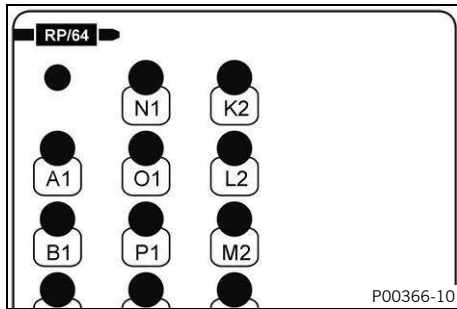

V Voltage measurement points
Bob box connector **RP** Pin **M4** – Measuring point **Ground (-)**

Voltage	< 0.1 V
---------	---------

- » Specification does not match set value
 - Check wire from Engine control unit connector **RP** (p. 218) pin **M4** to Lambda sensor connector **IM** (p. 216) pin **4** for a short circuit to plus (clamp 30).
- » If the specifications have been met:
 - Check the next possible cause
Lambda sensor heater – the control wire has a short circuit to ignition plus (terminal 15)

Lambda sensor heater – the control wire has a short circuit to ignition plus (terminal 15)

Condition

- + Diagnostic tool is disconnected
- + Engine control unit is disconnected (p. 23)
- + The breakout box is connected to the engine control unit main wiring harness with adapter **00029095016**
- + Oxygen sensor is disconnected (p. 13)
- Lambda sensor heater – check the control wire for a short circuit to ignition plus (terminal 15).

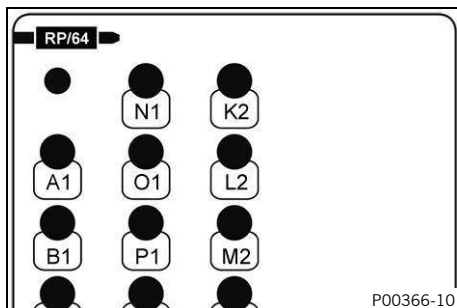



Ω Resistance measurement points
Bob box connector **RP** Pin **M4** – Bob box connector **RP** Pin **D4**

Resistance	$\infty \Omega$
------------	-----------------

- » Specification does not match set value
 - Check wire from Engine control unit connector **RP** (p. 218) pin **M4** to Lambda sensor connector **IM** (p. 216) pin **4** for a short circuit to ignition plus (clamp 15).

Last action

- Contact customer service.

Blink code for malfunction indicator light	 14: Malfunction indicator light flashes 1x long, 4x short
Display on diagnostic tool	P010100 «Crankcase pressure sensor» «Difference too high»
Error level condition	Crankcase pressure sensor – difference too high between sensor and engine control unit
Function check	Checking the crankcase pressure sensor  (p. 31)
Last action	– Contact customer service.

Checking the crankcase pressure sensor





- Check the hose of the crankcase pressure sensor for damage and dirt.
- Clear fault memory with diagnostic tool.
 - » Take a test ride.
 - Read out the fault memory using the diagnostics tool.



Last action



- Contact customer service.

3 Engine control trouble code

Blink code for malfunction indicator light	 09: Malfunction indicator light flashes 9x short
Display on diagnostic tool	P010711 «Crankcase pressure sensor» «Short circuit to ground»
Error level condition	Crankcase pressure sensor - short circuit to ground Voltage: ≤ 0.4 V Time: ≥ 0.1 s
Possible cause	Crankcase pressure sensor – the power supply is faulty  (p. 32) Crankcase pressure sensor - the signal wire has a short circuit to ground (terminal 31)  (p. 32) Crankcase pressure sensor – the signal wire has a short circuit to sensor ground  (p. 33)
Last action	– Contact customer service.

Crankcase pressure sensor – the power supply is faulty

Condition

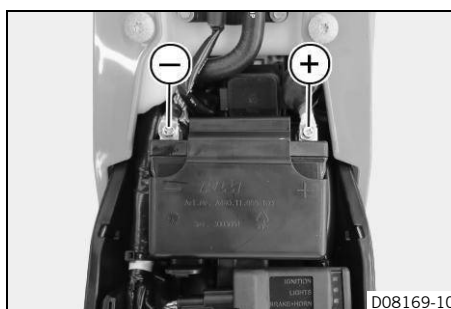
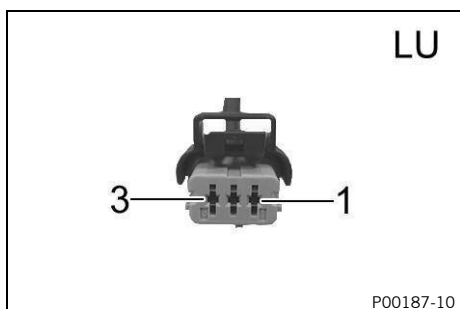

- + Diagnostic tool is connected and active
- + Engine control unit is connected  (p. 23)
- + Crank chamber pressure sensor is disconnected  (p. 18)
- Crankcase pressure sensor – check the power supply.



V Voltage measurement points
Crankcase pressure sensor connector **LU** Pin **1** – Measuring point **Ground (-)**

Voltage	4.8 V ... 5.2 V
---------	-----------------



i **Note**
For the measurement, the measuring points must be subjected to a 12 V/21 W bulb.

- » Specification does not match set value
 - Check Crankcase pressure sensor connector **LU**  (p. 217) pin **1**.
 - Check wire from Crankcase pressure sensor connector **LU**  (p. 217) pin **1** to the next node in the wiring harness.
- » If the specifications have been met:
 - Check the next possible cause
Crankcase pressure sensor - the signal wire has a short circuit to ground (terminal 31)

Crankcase pressure sensor - the signal wire has a short circuit to ground (terminal 31)

Condition

- + Diagnostic tool is disconnected

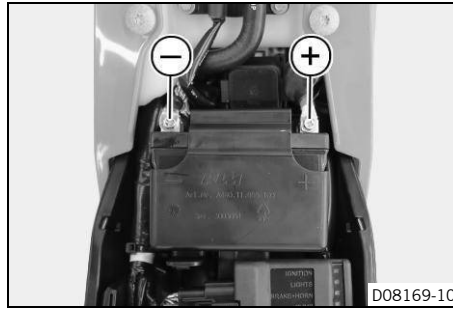
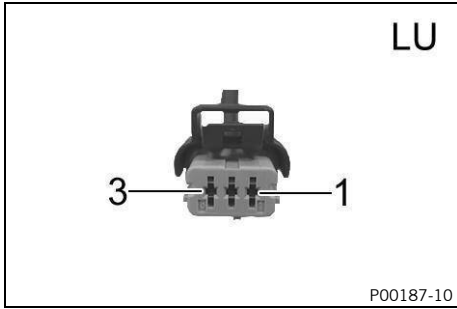

- + Engine control unit is disconnected  (p. 23)
- + Crank chamber pressure sensor is disconnected  (p. 18)
- Crankcase pressure sensor – check the signal wire for a short circuit to ground (terminal 31).



Resistance measurement points



Crankcase pressure sensor connector **LU** Pin **3** – Measuring point **Ground (-)**

Resistance	$\infty \Omega$
------------	-----------------

- » Specification does not match set value
 - Check wire from Crankcase pressure sensor connector **LU**  (p. 217) pin **3** to Engine control unit connector **RP**  (p. 218) pin **E1** for a short circuit to ground (clamp 31).
- » If the specifications have been met:
 - Check the next possible cause
 - Crankcase pressure sensor – the signal wire has a short circuit to sensor ground

Crankcase pressure sensor – the signal wire has a short circuit to sensor ground

Condition

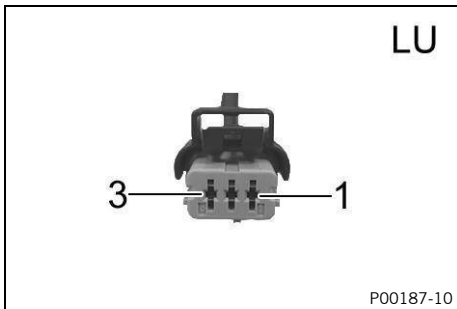

- + Diagnostic tool is disconnected
- + Engine control unit is disconnected  (p. 23)
- + Crank chamber pressure sensor is disconnected  (p. 18)
- Crankcase pressure sensor – check the signal wire for a short circuit to sensor ground.



Resistance measurement points

Crankcase pressure sensor connector **LU** Pin **3**
 – Crankcase pressure sensor connector **LU** Pin **2**







Resistance	$\infty \Omega$
------------	-----------------

- » Specification does not match set value
 - Check wire from Crankcase pressure sensor connector **LU**  (p. 217) pin **3** to Engine control unit connector **RP**  (p. 218) pin **E1** for a short circuit to sensor ground.

Last action



- Contact customer service.

3 Engine control trouble code

Blink code for malfunction indicator light	 09: Malfunction indicator light flashes 9x short
Display on diagnostic tool	P010812 «Crankcase pressure sensor» «Open/short circuit to plus»
Error level condition	Crankcase pressure sensor - open/short circuit to plus Voltage: ≥ 4.6 V Time: ≥ 0.1 s
Possible cause	Crankcase pressure sensor – the signal wire is faulty  (p. 34) Crankcase pressure sensor - the ground wire is faulty  (p. 35) Crankcase pressure sensor – the signal wire has a short circuit to plus (terminal 30)  (p. 35) Crankcase pressure sensor – the signal wire has a short circuit to ignition plus (terminal 15)  (p. 36) Crankcase pressure sensor – the signal wire has a short circuit to the sensor power supply  (p. 36)
Last action	– Contact customer service.

Crankcase pressure sensor – the signal wire is faulty

Condition



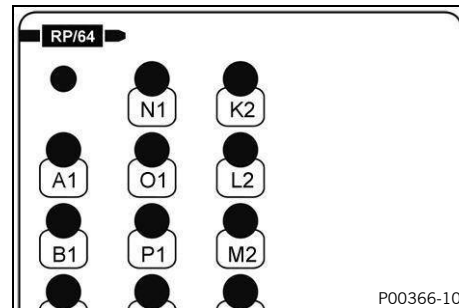
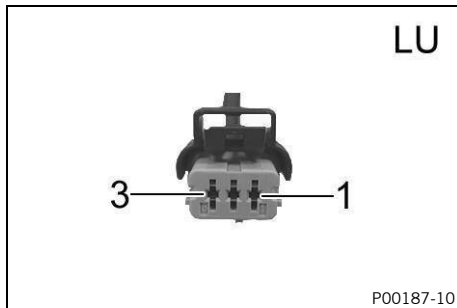

- + Diagnostic tool is disconnected
- + Engine control unit is disconnected  (p. 23)
- + The breakout box is connected to the engine control unit main wiring harness with adapter **00029095016**
- + Crank chamber pressure sensor is disconnected  (p. 18)
- Crankcase pressure sensor – check the signal wire.



Resistance measurement points



Bob box connector **RP** Pin **E1** – Crankcase pressure sensor connector **LU** Pin **3**

Resistance	$\leq 0.6 \Omega$
------------	-------------------

- » Specification does not match set value
 - Check Engine control unit connector **RP**  (p. 218) pin **E1** and Crankcase pressure sensor connector **LU**  (p. 217) pin **3**.
 - Check wire from Engine control unit connector **RP**  (p. 218) pin **E1** to Crankcase pressure sensor connector **LU**  (p. 217) pin **3**.
- » If the specifications have been met:
 - Check the next possible cause
Crankcase pressure sensor - the ground wire is faulty

Crankcase pressure sensor - the ground wire is faulty

Condition



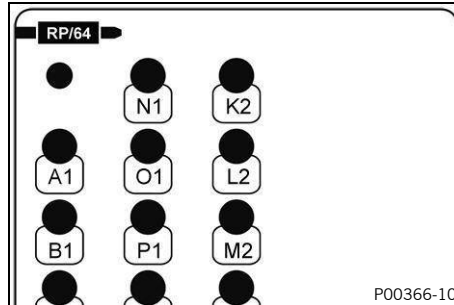
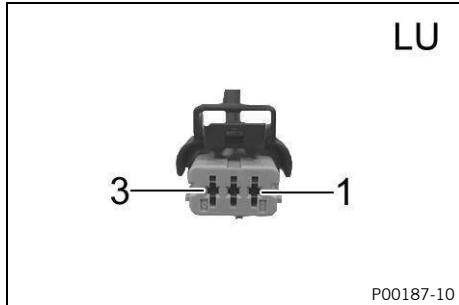

- + Diagnostic tool is disconnected
- + Engine control unit is disconnected  (p. 23)
- + The breakout box is connected to the engine control unit main wiring harness with adapter **00029095016**
- + Crank chamber pressure sensor is disconnected  (p. 18)
- Crankcase pressure sensor - check the ground wire.



Resistance measurement points



Bob box connector **RP** Pin **C2** – Crankcase pressure sensor connector **LU** Pin **2**

Resistance	≤ 0.6 Ω
------------	---------

- » Specification does not match set value
 - Check Engine control unit connector **RP**  (p. 218) pin **C2** and Crankcase pressure sensor connector **LU**  (p. 217) pin **2**.
 - Check wire from Engine control unit connector **RP**  (p. 218) pin **C2** to Crankcase pressure sensor connector **LU**  (p. 217) pin **2**.
- » If the specifications have been met:
 - Check the next possible cause
Crankcase pressure sensor – the signal wire has a short circuit to plus (terminal 30)

Crankcase pressure sensor – the signal wire has a short circuit to plus (terminal 30)

Condition

- + Diagnostic tool is disconnected
- + Engine control unit is disconnected  (p. 23)
- + The breakout box is connected to the engine control unit main wiring harness with adapter **00029095016**
- + Crank chamber pressure sensor is disconnected  (p. 18)
- Crankcase pressure sensor – check the signal wire for a short circuit to plus (terminal 30).

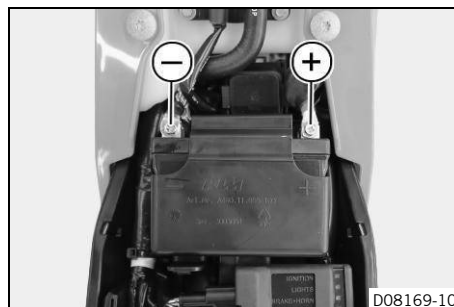
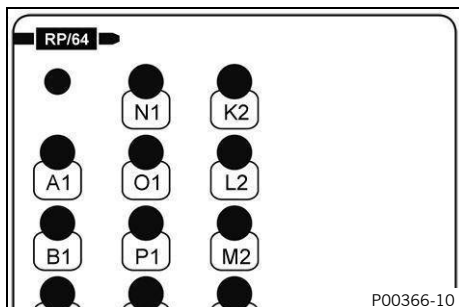

Voltage measurement points

Bob box connector **RP** Pin **E1** – Measuring point **Ground (-)**

3 Engine control trouble code

Voltage	< 0.1 V
---------	---------

- » Specification does not match set value
 - Check wire from Engine control unit connector **RP** (p. 218) pin **E1** to Crankcase pressure sensor connector **LU** (p. 217) pin **3** for a short circuit to plus (clamp 30).
- » If the specifications have been met:
 - Check the next possible cause
Crankcase pressure sensor – the signal wire has a short circuit to ignition plus (terminal 15)

Crankcase pressure sensor – the signal wire has a short circuit to ignition plus (terminal 15)

Condition

- + Diagnostic tool is disconnected
- + Engine control unit is disconnected (p. 23)
- + The breakout box is connected to the engine control unit main wiring harness with adapter **00029095016**
- + Crank chamber pressure sensor is disconnected (p. 18)
- Crankcase pressure sensor – check the signal wire for a short circuit to ignition plus (terminal 15).

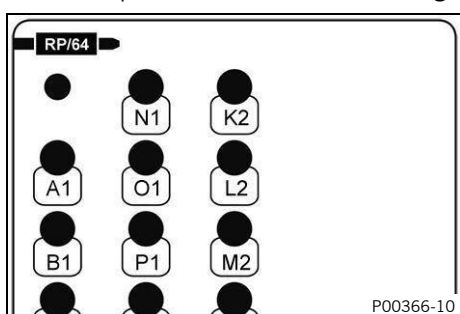

Resistance measurement points

Bob box connector **RP** Pin **E1** – Bob box connector **RP** Pin **D4**

Resistance	$\infty \Omega$
------------	-----------------

- » Specification does not match set value
 - Check wire from Engine control unit connector **RP** (p. 218) pin **E1** to Crankcase pressure sensor connector **LU** (p. 217) pin **3** for a short circuit to ignition plus (clamp 15).
- » If the specifications have been met:
 - Check the next possible cause
Crankcase pressure sensor – the signal wire has a short circuit to the sensor power supply

Crankcase pressure sensor – the signal wire has a short circuit to the sensor power supply

Condition

- + Diagnostic tool is disconnected
- + Engine control unit is disconnected (p. 23)
- + The breakout box is connected to the engine control unit main wiring harness with adapter **00029095016**
- + Crank chamber pressure sensor is disconnected (p. 18)
- Crankcase pressure sensor – check the signal wire for a short circuit to the sensor power supply.

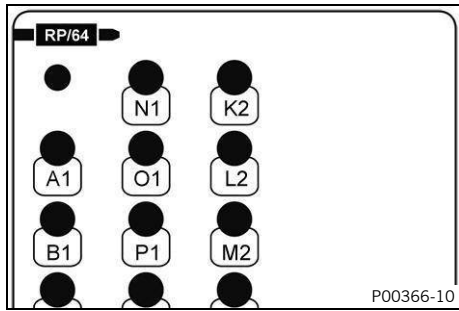

Resistance measurement points

Bob box connector **RP** Pin **E1** – Bob box connector **RP** Pin **D3**





Resistance	$\infty \Omega$
------------	-----------------

- » Specification does not match set value
 - Check wire from Engine control unit connector **RP** (p. 218) pin **E1** to Crankcase pressure sensor connector **LU** (p. 217) pin **3** for a short circuit to the sensor voltage supply.

Last action

- Contact customer service.

3 Engine control trouble code



Blink code for malfunction indicator light	 13: Malfunction indicator light flashes 1x long, 3x short
Display on diagnostic tool	P011211 «Intake air temperature sensor» «Input signal too low»
Error level condition	Intake air temperature sensor – input signal too low Voltage: ≤ 0.2 V Time: ≥ 3 s
Function check	Intake air temperature sensor - checking the temperature  (p. 38)
Possible cause	Intake air temperature sensor – the value is not plausible  (p. 38)
	Intake air temperature sensor – the signal wire has a short circuit to ground (terminal 31)  (p. 39)
	Intake air temperature sensor – the signal wire has a short circuit to sensor ground  (p. 39)
Last action	– Contact customer service.

Intake air temperature sensor - checking the temperature

Condition

- + Diagnostic tool is connected and active
- Select «**Engine control unit**» > «**Measured values**» > «**Intake air temperature**».

Air temperature is plausible.

- » If the displayed value is equal to the set value:
 - Clear fault memory with diagnostic tool.
 - Take a test ride.
 - Read out the fault memory using the diagnostics tool.
- » If the displayed value is below the setpoint value:
 - Intake air temperature sensor – the value is not plausible  (p. 38)
 - Intake air temperature sensor – the signal wire has a short circuit to ground (terminal 31)  (p. 39)
 - Intake air temperature sensor – the signal wire has a short circuit to sensor ground  (p. 39)

Intake air temperature sensor – the value is not plausible

Condition

- + Diagnostic tool is disconnected
- + Intake air temperature sensor is removed  (p. 19)
- Intake air temperature sensor – check the resistance.

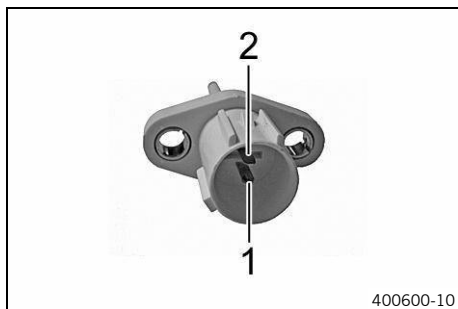

Resistance measurement points



Intake air temperature sensor Pin 1 – Intake air temperature sensor Pin 2

Intake air temperature sensor	
Resistance at: -20 °C (-4.0 °F)	18.80 kΩ
Voltage at: -20 °C (-4.0 °F)	4.67 V
Resistance at: 20 °C (68.0 °F)	2.942 kΩ
Voltage at: 20 °C (68.0 °F)	3.14 V
Resistance at: 40 °C (104.0 °F)	1.136 kΩ
Voltage at: 40 °C (104.0 °F)	2.15 V
Resistance at: 100 °C (212.0 °F)	0.1553 kΩ
Voltage at: 100 °C (212.0 °F)	0.46 V

- » Specification does not match set value
 - Change the intake air temperature sensor.
- » If the specifications have been met:
 - Check the next possible cause
 - Intake air temperature sensor – the signal wire has a short circuit to ground (terminal 31)

Intake air temperature sensor – the signal wire has a short circuit to ground (terminal 31)

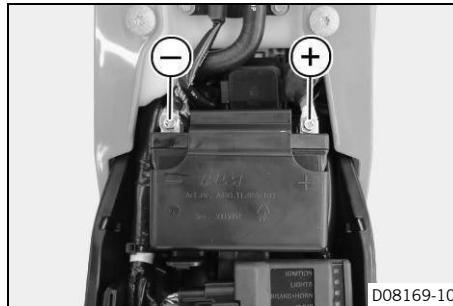
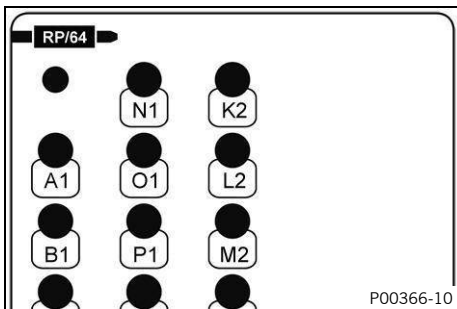

Condition

- + Diagnostic tool is disconnected
- + Engine control unit is disconnected  (p. 23)
- + The breakout box is connected to the engine control unit main wiring harness with adapter **00029095016**
- + Intake air temperature sensor is disconnected  (p. 19)
- Intake air temperature sensor – check the signal wire for a short circuit to ground (terminal 31).



 Resistance measurement points
 Bob box connector **RP** Pin **K1** – Measuring point **Ground (-)**

Resistance	$\infty \Omega$
------------	-----------------

- » Specification does not match set value
 - Check wire from Engine control unit connector **RP**  (p. 218) pin **K1** to Intake air temperature sensor connector **CM**  (p. 213) pin **2** for a short circuit to ground (clamp 31).
- » If the specifications have been met:
 - Check the next possible cause
 - Intake air temperature sensor – the signal wire has a short circuit to sensor ground

Intake air temperature sensor – the signal wire has a short circuit to sensor ground

Condition

- + Diagnostic tool is disconnected
- + Engine control unit is disconnected  (p. 23)
- + The breakout box is connected to the engine control unit main wiring harness with adapter **00029095016**

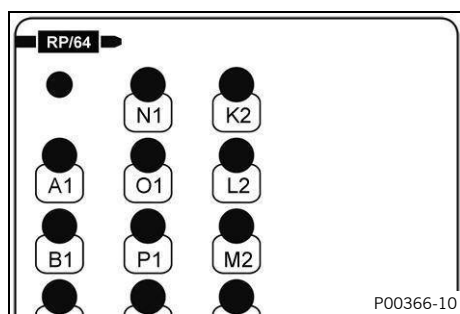

3 Engine control trouble code

- + Intake air temperature sensor is disconnected  (p. 19)
- Intake air temperature sensor – check the signal wire for a short circuit to sensor ground.











Resistance measurement points
Bob box connector **RP** Pin **K1** – Bob box connector **RP** Pin **J2**

Resistance	$\infty \Omega$
------------	-----------------

- » Specification does not match set value
 - Check wire from Engine control unit connector **RP**  (p. 218) pin **K1** to Intake air temperature sensor connector **CM**  (p. 213) pin **2** for a short circuit to sensor ground.

Last action

- Contact customer service.







Blink code for malfunction indicator light	 13: Malfunction indicator light flashes 1x long, 3x short
Display on diagnostic tool	P011312 «Intake air temperature sensor» «Input signal too high»
Error level condition	Intake air temperature sensor – input signal too high Voltage: ≥ 4.8 V Time: ≥ 3 s
Function check	Intake air temperature sensor - checking the temperature  (p. 41)
Possible cause	Intake air temperature sensor – the value is not plausible  (p. 41)
	Intake air temperature sensor – the signal wire is faulty  (p. 42)
	Intake air temperature sensor – the ground wire is faulty  (p. 43)
	Intake air temperature sensor – the signal wire has a short circuit to plus (terminal 30)  (p. 43)
	Intake air temperature sensor – the signal wire has a short circuit to ignition plus (terminal 15)  (p. 44)
	Intake air temperature sensor – the signal wire has a short circuit to the sensor power supply  (p. 44)
Last action	– Contact customer service.

Intake air temperature sensor - checking the temperature

Condition

- + Diagnostic tool is connected and active
- Select «**Engine control unit**» > «**Measured values**» > «**Intake air temperature**».

Air temperature is plausible.

- » If the displayed value is equal to the set value:
 - Clear fault memory with diagnostic tool.
 - Take a test ride.
 - Read out the fault memory using the diagnostics tool.
- » If the displayed value is above the setpoint value:
 - Intake air temperature sensor – the value is not plausible  (p. 41)
 - Intake air temperature sensor – the signal wire is faulty  (p. 42)
 - Intake air temperature sensor – the ground wire is faulty  (p. 43)
 - Intake air temperature sensor – the signal wire has a short circuit to plus (terminal 30)  (p. 43)
 - Intake air temperature sensor – the signal wire has a short circuit to ignition plus (terminal 15)  (p. 44)
 - Intake air temperature sensor – the signal wire has a short circuit to the sensor power supply  (p. 44)



Intake air temperature sensor – the value is not plausible

Condition

- + Diagnostic tool is disconnected
- + Intake air temperature sensor is removed  (p. 19)
- Intake air temperature sensor – check the resistance.

3 Engine control trouble code

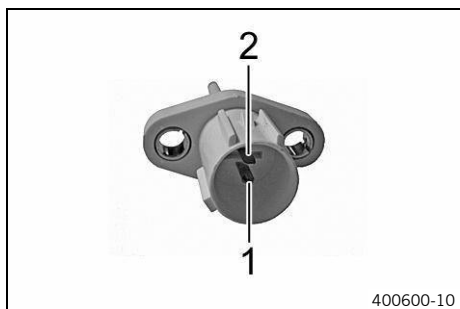

Resistance measurement points

Intake air temperature sensor Pin 1 – Intake air temperature sensor Pin 2

Intake air temperature sensor	
Resistance at: -20 °C (-4.0 °F)	18.80 kΩ
Voltage at: -20 °C (-4.0 °F)	4.67 V
Resistance at: 20 °C (68.0 °F)	2.942 kΩ
Voltage at: 20 °C (68.0 °F)	3.14 V
Resistance at: 40 °C (104.0 °F)	1.136 kΩ
Voltage at: 40 °C (104.0 °F)	2.15 V
Resistance at: 100 °C (212.0 °F)	0.1553 kΩ
Voltage at: 100 °C (212.0 °F)	0.46 V

- » Specification does not match set value
 - Change the intake air temperature sensor.
- » If the specifications have been met:
 - Check the next possible cause
 - Intake air temperature sensor – the signal wire is faulty

Intake air temperature sensor – the signal wire is faulty

Condition

- + Diagnostic tool is disconnected
- + Engine control unit is disconnected (p. 23)
- + The breakout box is connected to the engine control unit main wiring harness with adapter **00029095016**
- + Intake air temperature sensor is disconnected (p. 19)
- Intake air temperature sensor – check the signal wire.

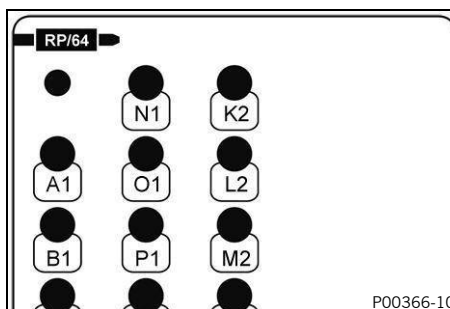
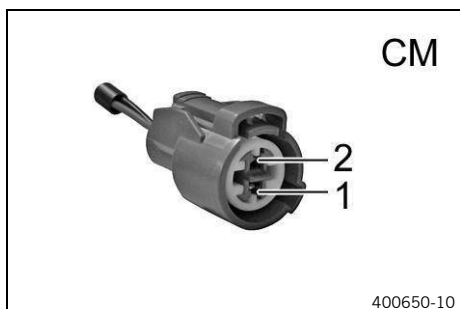

Resistance measurement points

Bob box connector **RP** Pin **K1** – Intake air temperature sensor connector **CM** Pin **2**

Resistance	≤ 0.6 Ω
------------	---------

- » Specification does not match set value
 - Check Engine control unit connector **RP** (p. 218) pin **K1** and Intake air temperature sensor connector **CM** (p. 213) pin **2**.

- Check wire from Engine control unit connector **RP** (p. 218) pin **K1** to Intake air temperature sensor connector **CM** (p. 213) pin **2**.
- » If the specifications have been met:
 - Check the next possible cause
 - Intake air temperature sensor – the ground wire is faulty

Intake air temperature sensor – the ground wire is faulty

Condition

- + Diagnostic tool is disconnected
- + Engine control unit is disconnected (p. 23)
- + The breakout box is connected to the engine control unit main wiring harness with adapter **00029095016**
- + Intake air temperature sensor is disconnected (p. 19)
- + Coolant temperature sensor is disconnected (p. 14)
- + Oxygen sensor is disconnected (p. 13)
- Intake air temperature sensor – check the ground wire.

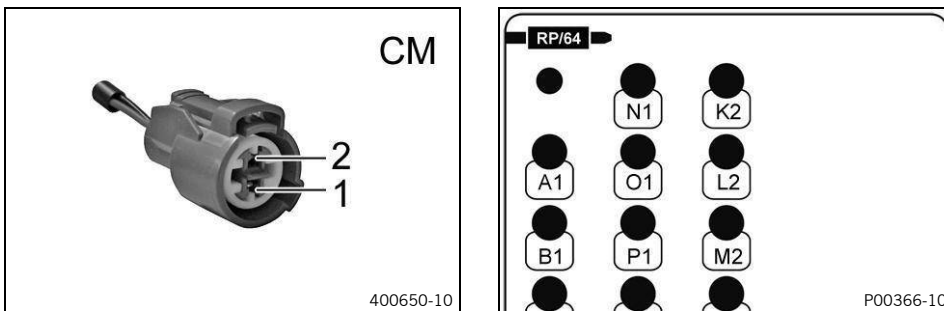

Resistance measurement points

Bob box connector **RP** Pin **J2** – Intake air temperature sensor connector **CM** Pin **1**

Resistance	$\leq 0.6 \Omega$
------------	-------------------

- » Specification does not match set value
 - Check Engine control unit connector **RP** (p. 218) pin **J2** and Intake air temperature sensor connector **CM** (p. 213) pin **1**.
 - Check wire from Engine control unit connector **RP** (p. 218) pin **J2** to Intake air temperature sensor connector **CM** (p. 213) pin **1**.
- » If the specifications have been met:
 - Check the next possible cause
 - Intake air temperature sensor – the signal wire has a short circuit to plus (terminal 30)

Intake air temperature sensor – the signal wire has a short circuit to plus (terminal 30)

Condition

- + Diagnostic tool is disconnected
- + Engine control unit is disconnected (p. 23)
- + The breakout box is connected to the engine control unit main wiring harness with adapter **00029095016**
- + Intake air temperature sensor is disconnected (p. 19)
- Intake air temperature sensor – check the signal wire for a short circuit to plus (terminal 30).

3 Engine control trouble code

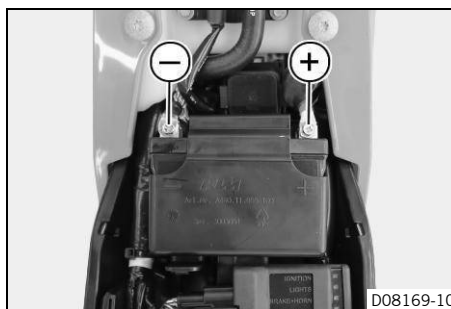
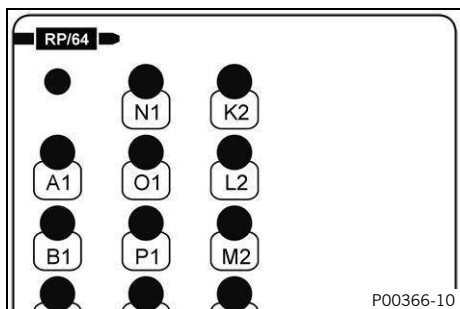

V Voltage measurement points
Bob box connector **RP** Pin **K1** – Measuring point **Ground (-)**

Voltage	$\leq 0.1 \text{ V}$
---------	----------------------

- » Specification does not match set value
 - Check wire from Engine control unit connector **RP** (p. 218) pin **K1** to Intake air temperature sensor connector **CM** (p. 213) pin **2** for a short circuit to plus (clamp 30).
- » If the specifications have been met:
 - Check the next possible cause
Intake air temperature sensor – the signal wire has a short circuit to ignition plus (terminal 15)

Intake air temperature sensor – the signal wire has a short circuit to ignition plus (terminal 15)

Condition

- + Diagnostic tool is disconnected
- + Engine control unit is disconnected (p. 23)
- + The breakout box is connected to the engine control unit main wiring harness with adapter **00029095016**
- + Intake air temperature sensor is disconnected (p. 19)
- Intake air temperature sensor – check the signal wire for a short circuit to ignition plus (terminal 15).

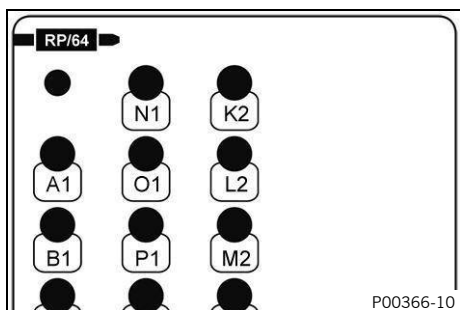

Ω Resistance measurement points
Bob box connector **RP** Pin **K1** – Bob box connector **RP** Pin **D4**

Resistance	$\infty \Omega$
------------	-----------------

- » Specification does not match set value
 - Check wire from Engine control unit connector **RP** (p. 218) pin **K1** to Intake air temperature sensor connector **CM** (p. 213) pin **2** for a short circuit to ignition plus (clamp 15).
- » If the specifications have been met:
 - Check the next possible cause
Intake air temperature sensor – the signal wire has a short circuit to the sensor power supply

Intake air temperature sensor – the signal wire has a short circuit to the sensor power supply

Condition

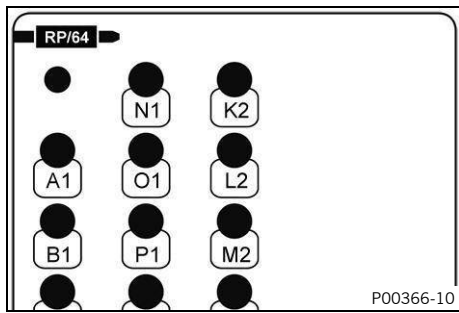

- + Diagnostic tool is disconnected
- + Engine control unit is disconnected (p. 23)
- + The breakout box is connected to the engine control unit main wiring harness with adapter **00029095016**

- + Intake air temperature sensor is disconnected  (p. 19)
- Intake air temperature sensor – check the signal wire for a short circuit to the sensor power supply.



 Resistance measurement points
 Bob box connector **RP** Pin **K1** – Bob box connector **RP**
 Pin **D3**





Resistance	$\infty \Omega$
------------	-----------------

- » Specification does not match set value
 - Check wire from Engine control unit connector **RP**  (p. 218) pin **K1** to Intake air temperature sensor connector **CM**  (p. 213) pin **2** for a short circuit to the sensor voltage supply.

Last action

- Contact customer service.

3 Engine control trouble code



Blink code for malfunction indicator light	 12: Malfunction indicator light flashes 1x long, 2x short
Display on diagnostic tool	P011711 «Coolant temperature sensor» «Input signal too low»
Error level condition	Coolant temperature sensor – input signal too low Voltage: ≤ 0.1 V Time: ≥ 3 s
Function check	Coolant temperature sensor – checking the temperature  (p. 46)
Possible cause	Coolant temperature sensor – the value is not plausible  (p. 46)
	Coolant temperature sensor – the signal wire has a short circuit to ground (terminal 31)  (p. 47)
	Coolant temperature sensor – the signal wire has a short circuit to sensor ground  (p. 48)
Last action	– Contact customer service.

Coolant temperature sensor – checking the temperature

Condition

- + Diagnostic tool is connected and active
- Select «**Engine control unit**» > «**Measured values**» > «**Coolant temperature**».

Engine temperature is plausible.

- » If the displayed value is equal to the set value:
 - Clear fault memory with diagnostic tool.
 - Take a test ride.
 - Read out the fault memory using the diagnostics tool.
- » If the displayed value is below the setpoint value:
 - Coolant temperature sensor – the value is not plausible  (p. 46)
 - Coolant temperature sensor – the signal wire has a short circuit to ground (terminal 31)  (p. 47)
 - Coolant temperature sensor – the signal wire has a short circuit to sensor ground  (p. 48)

Coolant temperature sensor – the value is not plausible

Condition

- + Diagnostic tool is disconnected
- + Coolant temperature sensor is disconnected  (p. 14)
- Coolant temperature sensor – check the resistance.

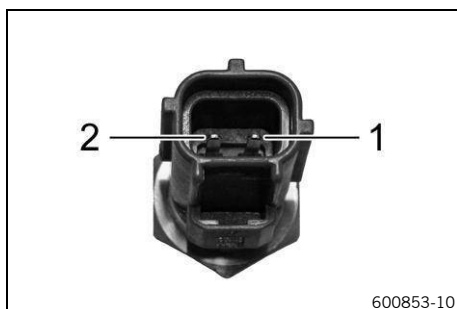



 Resistance measurement points
Coolant temperature sensor Pin 1 – Coolant temperature sensor Pin 2

Coolant temperature sensor	
Resistance at: -20 °C (-4.0 °F)	13.50 kΩ ... 16.50 kΩ
Voltage at: -20 °C (-4.0 °F)	4.5 V
Resistance at: -10 °C (14.0 °F)	8.24 kΩ ... 10.08 kΩ
Voltage at: -10 °C (14.0 °F)	4.3 V
Resistance at: 0 °C (32.0 °F)	5.17 kΩ ... 6.31 kΩ
Voltage at: 0 °C (32.0 °F)	3.9 V
Resistance at: 10 °C (50.0 °F)	3.33 kΩ ... 4.07 kΩ
Voltage at: 10 °C (50.0 °F)	3.5 V
Resistance at: 20 °C (68.0 °F)	2.21 kΩ ... 2.70 kΩ
Voltage at: 20 °C (68.0 °F)	3.1 V
Resistance at: 30 °C (86.0 °F)	1.49 kΩ ... 1.83 kΩ
Voltage at: 30 °C (86.0 °F)	2.5 V
Resistance at: 40 °C (104.0 °F)	1.04 kΩ ... 1.27 kΩ
Voltage at: 40 °C (104.0 °F)	2.1 V
Resistance at: 50 °C (122.0 °F)	730 Ω ... 892 Ω
Voltage at: 50 °C (122.0 °F)	1.7 V
Resistance at: 60 °C (140.0 °F)	526 Ω ... 642 Ω
Voltage at: 60 °C (140.0 °F)	1.4 V
Resistance at: 70 °C (158.0 °F)	385 Ω ... 471 Ω
Voltage at: 70 °C (158.0 °F)	1.0 V
Resistance at: 80 °C (176.0 °F)	286 Ω ... 350 Ω
Voltage at: 80 °C (176.0 °F)	0.86 V
Resistance at: 90 °C (194.0 °F)	216 Ω ... 264 Ω
Voltage at: 90 °C (194.0 °F)	0.68 V
Resistance at: 100 °C (212.0 °F)	165 Ω ... 202 Ω
Voltage at: 100 °C (212.0 °F)	0.6 V
Resistance at: 110 °C (230.0 °F)	128 Ω ... 156 Ω
Voltage at: 110 °C (230.0 °F)	0.44 V
Resistance at: 120 °C (248.0 °F)	100 Ω ... 122 Ω
Voltage at: 120 °C (248.0 °F)	0.34 V

- » Specification does not match set value
 - Change the coolant temperature sensor.
- » If the specifications have been met:
 - Check the next possible cause
 - Coolant temperature sensor – the signal wire has a short circuit to ground (terminal 31)

Coolant temperature sensor – the signal wire has a short circuit to ground (terminal 31)

Condition

- + Diagnostic tool is disconnected
- + Engine control unit is disconnected  (p. 23)
- + The breakout box is connected to the engine control unit main wiring harness with adapter **00029095016**
- + Coolant temperature sensor is disconnected  (p. 14)
- Coolant temperature sensor – check the signal wire for a short circuit to ground (terminal 31).

3 Engine control trouble code

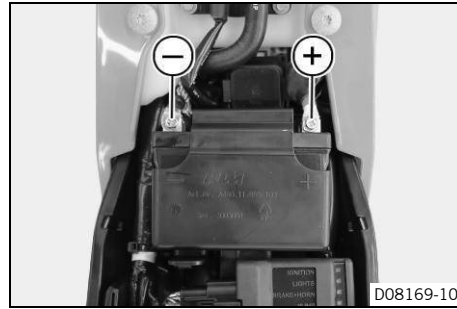
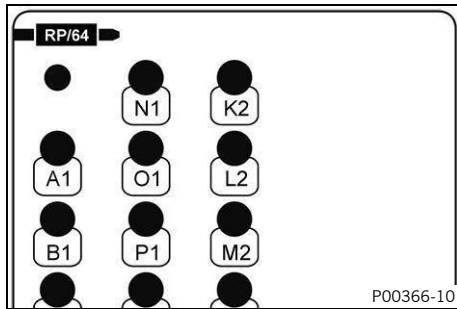

Resistance measurement points
Bob box connector **RP** Pin **K3** – Measuring point **Ground (-)**

Resistance	$\infty \Omega$
------------	-----------------

- » Specification does not match set value
 - Check wire from Engine control unit connector **RP** (p. 218) pin **K3** to Coolant temperature sensor connector **HV** (p. 215) pin **1** for a short circuit to ground (clamp 31).
- » If the specifications have been met:
 - Check the next possible cause
Coolant temperature sensor – the signal wire has a short circuit to sensor ground

Coolant temperature sensor – the signal wire has a short circuit to sensor ground

Condition

- + Diagnostic tool is disconnected
- + Engine control unit is disconnected (p. 23)
- + The breakout box is connected to the engine control unit main wiring harness with adapter **00029095016**
- + Coolant temperature sensor is disconnected (p. 14)
- Coolant temperature sensor – check the signal wire for a short circuit to sensor ground.

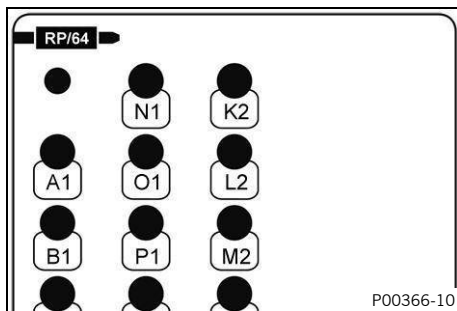









Resistance measurement points
Bob box connector **RP** Pin **K3** – Bob box connector **RP** Pin **J2**

Resistance	$\infty \Omega$
------------	-----------------

- » Specification does not match set value
 - Check wire from Engine control unit connector **RP** (p. 218) pin **K3** to Coolant temperature sensor connector **HV** (p. 215) pin **1** for a short circuit to sensor ground.

Last action

- Contact customer service.







Blink code for malfunction indicator light	 12: Malfunction indicator light flashes 1x long, 2x short
Display on diagnostic tool	P011812 «Coolant temperature sensor» «Input signal too high»
Error level condition	Coolant temperature sensor – input signal too high Voltage: ≥ 4.8 V Time: ≥ 3 s
Function check	Coolant temperature sensor – checking the temperature  (p. 49)
Possible cause	Coolant temperature sensor – the value is not plausible  (p. 49)
	Coolant temperature sensor – the signal wire is faulty  (p. 51)
	Coolant temperature sensor - the ground wire is faulty  (p. 51)
	Coolant temperature sensor – the signal wire has a short circuit to plus (terminal 30)  (p. 52)
	Coolant temperature sensor – the signal wire has a short circuit to ignition plus (terminal 15)  (p. 53)
	Coolant temperature sensor – the signal wire has a short circuit to the sensor power supply  (p. 53)
Last action	– Contact customer service.

Coolant temperature sensor – checking the temperature

Condition

- + Diagnostic tool is connected and active
- Select «**Engine control unit**» > «**Measured values**» > «**Coolant temperature**».

Engine temperature is plausible.

- » If the displayed value is equal to the set value:
 - Clear fault memory with diagnostic tool.
 - Take a test ride.
 - Read out the fault memory using the diagnostics tool.
- » If the displayed value is above the setpoint value:
 - Coolant temperature sensor – the value is not plausible  (p. 49)
 - Coolant temperature sensor – the signal wire is faulty  (p. 51)
 - Coolant temperature sensor - the ground wire is faulty  (p. 51)
 - Coolant temperature sensor – the signal wire has a short circuit to plus (terminal 30)  (p. 52)
 - Coolant temperature sensor – the signal wire has a short circuit to ignition plus (terminal 15)  (p. 53)
 - Coolant temperature sensor – the signal wire has a short circuit to the sensor power supply  (p. 53)



Coolant temperature sensor – the value is not plausible

Condition

- + Diagnostic tool is disconnected
- + Coolant temperature sensor is disconnected  (p. 14)
- Coolant temperature sensor – check the resistance.

3 Engine control trouble code

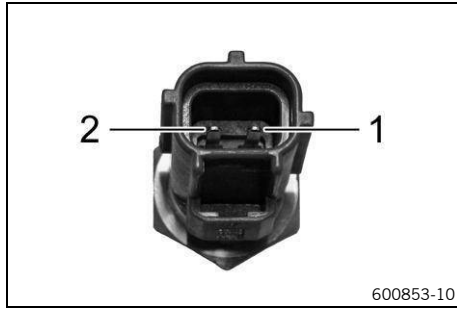



Ω Resistance measurement points
Coolant temperature sensor Pin 1 – Coolant temperature sensor Pin 2

Coolant temperature sensor	
Resistance at: -20 °C (-4.0 °F)	13.50 k Ω ... 16.50 k Ω
Voltage at: -20 °C (-4.0 °F)	4.5 V
Resistance at: -10 °C (14.0 °F)	8.24 k Ω ... 10.08 k Ω
Voltage at: -10 °C (14.0 °F)	4.3 V
Resistance at: 0 °C (32.0 °F)	5.17 k Ω ... 6.31 k Ω
Voltage at: 0 °C (32.0 °F)	3.9 V
Resistance at: 10 °C (50.0 °F)	3.33 k Ω ... 4.07 k Ω
Voltage at: 10 °C (50.0 °F)	3.5 V
Resistance at: 20 °C (68.0 °F)	2.21 k Ω ... 2.70 k Ω
Voltage at: 20 °C (68.0 °F)	3.1 V
Resistance at: 30 °C (86.0 °F)	1.49 k Ω ... 1.83 k Ω
Voltage at: 30 °C (86.0 °F)	2.5 V
Resistance at: 40 °C (104.0 °F)	1.04 k Ω ... 1.27 k Ω
Voltage at: 40 °C (104.0 °F)	2.1 V
Resistance at: 50 °C (122.0 °F)	730 Ω ... 892 Ω
Voltage at: 50 °C (122.0 °F)	1.7 V
Resistance at: 60 °C (140.0 °F)	526 Ω ... 642 Ω
Voltage at: 60 °C (140.0 °F)	1.4 V
Resistance at: 70 °C (158.0 °F)	385 Ω ... 471 Ω
Voltage at: 70 °C (158.0 °F)	1.0 V
Resistance at: 80 °C (176.0 °F)	286 Ω ... 350 Ω
Voltage at: 80 °C (176.0 °F)	0.86 V
Resistance at: 90 °C (194.0 °F)	216 Ω ... 264 Ω
Voltage at: 90 °C (194.0 °F)	0.68 V
Resistance at: 100 °C (212.0 °F)	165 Ω ... 202 Ω
Voltage at: 100 °C (212.0 °F)	0.6 V
Resistance at: 110 °C (230.0 °F)	128 Ω ... 156 Ω
Voltage at: 110 °C (230.0 °F)	0.44 V
Resistance at: 120 °C (248.0 °F)	100 Ω ... 122 Ω
Voltage at: 120 °C (248.0 °F)	0.34 V

- » Specification does not match set value
 - Change the coolant temperature sensor.
- » If the specifications have been met:
 - Check the next possible cause
 - Coolant temperature sensor – the signal wire is faulty

Coolant temperature sensor – the signal wire is faulty

Condition



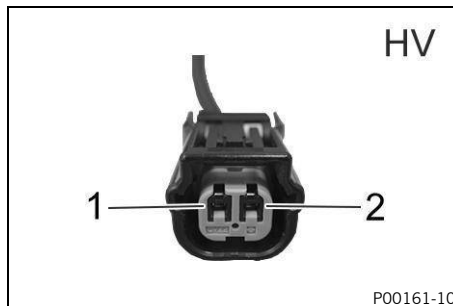
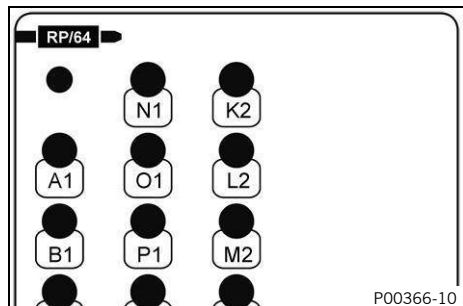

- + Diagnostic tool is disconnected
- + Engine control unit is disconnected  (p. 23)
- + The breakout box is connected to the engine control unit main wiring harness with adapter **00029095016**
- + Coolant temperature sensor is disconnected  (p. 14)
- Coolant temperature sensor – check the signal wire.



Resistance measurement points





Bob box connector **RP** Pin **K3** – Coolant temperature sensor connector **HV** Pin **1**

Resistance	$\leq 0.6 \Omega$
------------	-------------------

- » Specification does not match set value
 - Check Engine control unit connector **RP**  (p. 218) pin **K3** and Coolant temperature sensor connector **HV**  (p. 215) pin **1**.
 - Check wire from Engine control unit connector **RP**  (p. 218) pin **K3** to Coolant temperature sensor connector **HV**  (p. 215) pin **1**.
- » If the specifications have been met:
 - Check the next possible cause
Coolant temperature sensor - the ground wire is faulty

Coolant temperature sensor - the ground wire is faulty

Condition

- + Diagnostic tool is disconnected
- + Engine control unit is disconnected  (p. 23)
- + The breakout box is connected to the engine control unit main wiring harness with adapter **00029095016**
- + Coolant temperature sensor is disconnected  (p. 14)
- + Intake air temperature sensor is disconnected  (p. 19)
- + Oxygen sensor is disconnected  (p. 13)
- Coolant temperature sensor – check the ground wire.

3 Engine control trouble code

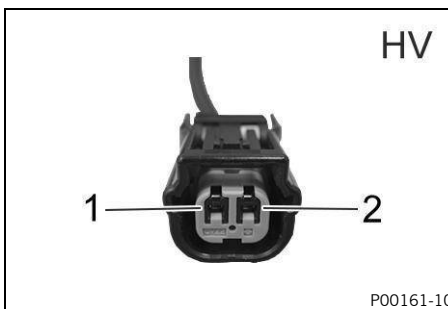
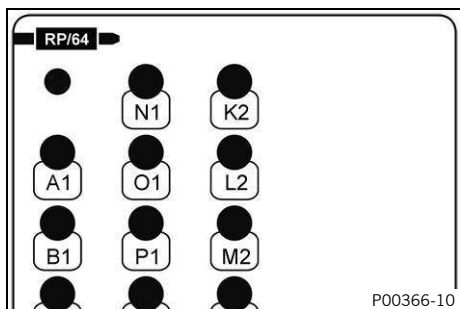

Resistance measurement points

Bob box connector **RP** Pin **J2** – Coolant temperature sensor connector **HV** Pin **2**

Resistance	$\leq 0.6 \Omega$
------------	-------------------

- » Specification does not match set value
 - Check Engine control unit connector **RP** (p. 218) pin **J2** and Coolant temperature sensor connector **HV** (p. 215) pin **2**.
 - Check wire from Engine control unit connector **RP** (p. 218) pin **J2** to Coolant temperature sensor connector **HV** (p. 215) pin **2**.
- » If the specifications have been met:
 - Check the next possible cause
Coolant temperature sensor – the signal wire has a short circuit to plus (terminal 30)

Coolant temperature sensor – the signal wire has a short circuit to plus (terminal 30)

Condition

- + Diagnostic tool is disconnected
- + Engine control unit is disconnected (p. 23)
- + The breakout box is connected to the engine control unit main wiring harness with adapter **00029095016**
- + Coolant temperature sensor is disconnected (p. 14)
- Coolant temperature sensor – check the signal wire for a short circuit to plus (terminal 30).

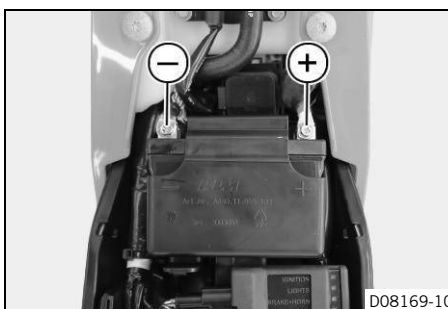
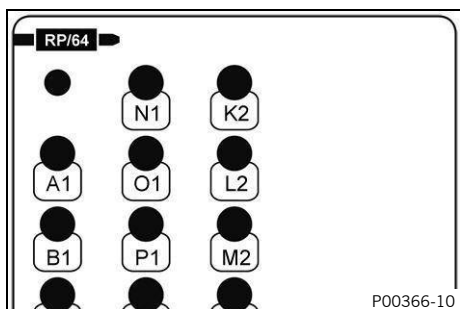

Voltage measurement points

Bob box connector **RP** Pin **K3** – Measuring point **Ground (-)**

Voltage	$\leq 0.1 \text{ V}$
---------	----------------------

- » Specification does not match set value
 - Check wire from Engine control unit connector **RP** (p. 218) pin **K3** to Coolant temperature sensor connector **HV** (p. 215) pin **1** for a short circuit to plus (clamp 30).
- » If the specifications have been met:
 - Check the next possible cause
Coolant temperature sensor – the signal wire has a short circuit to ignition plus (terminal 15)

Coolant temperature sensor – the signal wire has a short circuit to ignition plus (terminal 15)

Condition

- + Diagnostic tool is disconnected
- + Engine control unit is disconnected (p. 23)
- + The breakout box is connected to the engine control unit main wiring harness with adapter **00029095016**
- + Coolant temperature sensor is disconnected (p. 14)
- Coolant temperature sensor – check the signal wire for a short circuit to ignition plus (terminal 15).

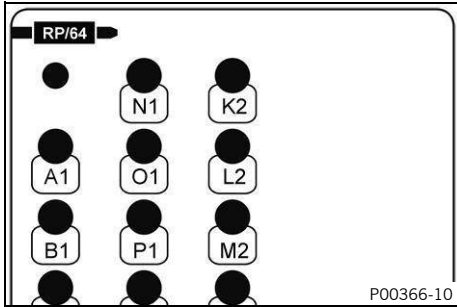

Resistance measurement points
 Bob box connector **RP** Pin **K3** – Bob box connector **RP** Pin **D4**

Resistance	$\infty \Omega$
------------	-----------------

- » Specification does not match set value
 - Check wire from Engine control unit connector **RP** (p. 218) pin **K3** to Coolant temperature sensor connector **HV** (p. 215) pin **1** for a short circuit to ignition plus (clamp 15).
- » If the specifications have been met:
 - Check the next possible cause
 Coolant temperature sensor – the signal wire has a short circuit to the sensor power supply

Coolant temperature sensor – the signal wire has a short circuit to the sensor power supply

Condition

- + Diagnostic tool is disconnected
- + Engine control unit is disconnected (p. 23)
- + The breakout box is connected to the engine control unit main wiring harness with adapter **00029095016**
- + Coolant temperature sensor is disconnected (p. 14)
- Coolant temperature sensor – check the signal wire for a short circuit to the sensor power supply.

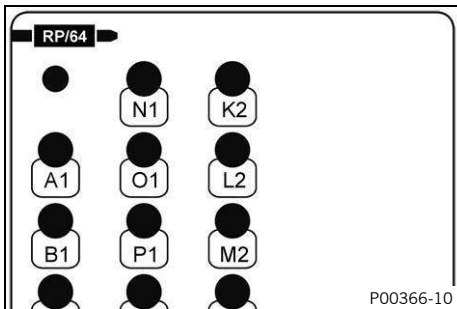

Resistance measurement points
 Bob box connector **RP** Pin **K3** – Bob box connector **RP** Pin **D3**







Resistance	$\infty \Omega$
------------	-----------------

- » Specification does not match set value
 - Check wire from Engine control unit connector **RP** (p. 218) pin **K3** to Coolant temperature sensor connector **HV** (p. 215) pin **1** for a short circuit to the sensor voltage supply.

Last action

- Contact customer service.

3 Engine control trouble code





Blink code for malfunction indicator light	 06: Malfunction indicator light flashes 6x short
Display on diagnostic tool	P012211 «Throttle valve position sensor circuit A» «Input signal too low»
Error level condition	Throttle valve position sensor circuit A – input signal too low Voltage: ≤ 0.2 V Time: ≥ 0.08 s
Function check	Throttle valve position sensor circuit A - checking the voltage  (p. 54)
Possible cause	Throttle valve position sensor circuit A – the power supply is faulty  (p. 54)
	Throttle valve position sensor circuit A – signal wire is faulty  (p. 55)
	Throttle valve position sensor circuit A – the signal wire has a short circuit to ground (terminal 31)  (p. 56)
	Throttle valve position sensor circuit A – the signal wire has a short circuit to sensor ground  (p. 56)
Last action	– Contact customer service.

Throttle valve position sensor circuit A - checking the voltage

Condition



- + Diagnostic tool is connected and active
- Select «**Engine control unit**» > «**Measured values**» > «**Throttle position sensor voltage**» and «**Throttle valve position**».
- Slowly and evenly turn the throttle grip all the way.

Circuit A throttle valve position sensor	0.42 V ... 4.6 V
Circuit A throttle valve position sensor	1.5° ... 84.5° (0.026 rad ... 1.475 rad)

- » If the displayed value is equal to the set value:
 - Clear fault memory with diagnostic tool.
 - Take a test ride.
 - Read out the fault memory using the diagnostics tool.
- » If the displayed value is below the setpoint value:
 - Throttle valve position sensor circuit A – the power supply is faulty  (p. 54)
 - Throttle valve position sensor circuit A – signal wire is faulty  (p. 55)
 - Throttle valve position sensor circuit A – the signal wire has a short circuit to ground (terminal 31)  (p. 56)
 - Throttle valve position sensor circuit A – the signal wire has a short circuit to sensor ground  (p. 56)

Throttle valve position sensor circuit A – the power supply is faulty

Condition

- + Diagnostic tool is connected and active
- + Engine control unit is connected  (p. 23)
- + Throttle position sensor circuit A is disconnected  (p. 21)
- Throttle valve position sensor circuit A – check the power supply.

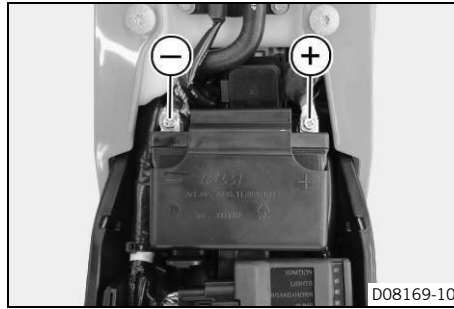
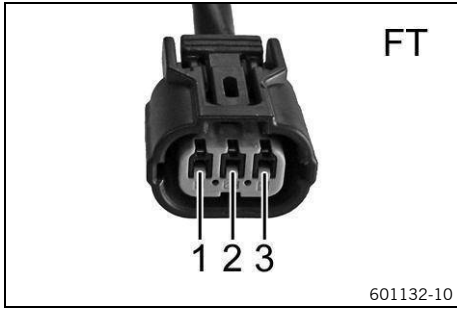

V Voltage measurement points
Throttle valve position sensor circuit A, connector **FT** Pin **1** – Measuring point **Ground (-)**

Voltage	4.8 V ... 5.2 V
---------	-----------------

i Note
For the measurement, the measuring points must be subjected to a 12 V/21 W bulb.

- » Specification does not match set value
 - Check wire from Throttle valve position sensor circuit A, connector **FT** (p. 214) pin **1** to Engine control unit connector **RP** (p. 218) pin **D2**.
- » If the specifications have been met:
 - Check the next possible cause
Throttle valve position sensor circuit A – signal wire is faulty

Throttle valve position sensor circuit A – signal wire is faulty

Condition

- + Diagnostic tool is disconnected
- + Engine control unit is disconnected (p. 23)
- + The breakout box is connected to the engine control unit main wiring harness with adapter **00029095016**
- + Throttle position sensor circuit A is disconnected (p. 21)
- Throttle valve position sensor circuit A – check the signal wire.

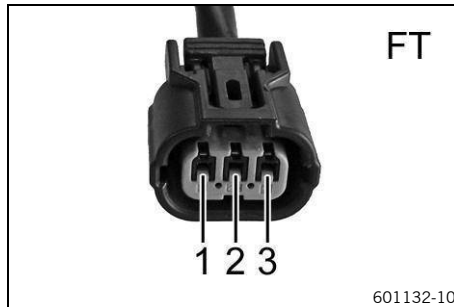
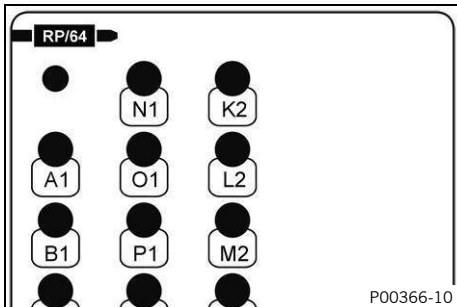

Ω Resistance measurement points
Bob box connector **RP** Pin **G3** – Throttle valve position sensor circuit A, connector **FT** Pin **2**

Resistance	≤ 0.6 Ω
------------	---------



- » Specification does not match set value
 - Check Engine control unit connector **RP** (p. 218) pin **G3** and Throttle valve position sensor circuit A, connector **FT** (p. 214) pin **2**.
 - Check wire from Engine control unit connector **RP** (p. 218) pin **G3** to Throttle valve position sensor circuit A, connector **FT** (p. 214) pin **2**.

3 Engine control trouble code

- » If the specifications have been met:
 - Check the next possible cause
 - Throttle valve position sensor circuit A – the signal wire has a short circuit to ground (terminal 31)

Throttle valve position sensor circuit A – the signal wire has a short circuit to ground (terminal 31)

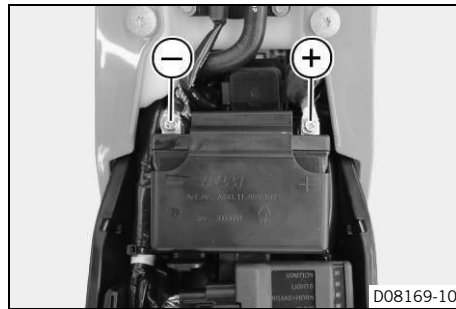
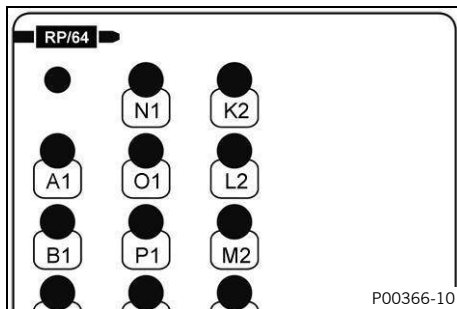

Condition

- + Diagnostic tool is disconnected
- + Engine control unit is disconnected  (p. 23)
- + The breakout box is connected to the engine control unit main wiring harness with adapter **00029095016**
- + Throttle position sensor circuit A is disconnected  (p. 21)
- Throttle valve position sensor circuit A – check the signal wire for a short circuit to ground (terminal 31).





 Resistance measurement points
Bob box connector **RP** Pin **G3** – Measuring point **Ground (-)**

Resistance	$\infty \Omega$
------------	-----------------

- » Specification does not match set value
 - Check wire from Engine control unit connector **RP**  (p. 218) pin **G3** to Throttle valve position sensor circuit A, connector **FT**  (p. 214) pin **2** for a short circuit to ground (clamp 31).
- » If the specifications have been met:
 - Check the next possible cause
 - Throttle valve position sensor circuit A – the signal wire has a short circuit to sensor ground

Throttle valve position sensor circuit A – the signal wire has a short circuit to sensor ground

Condition

- + Diagnostic tool is disconnected
- + Engine control unit is disconnected  (p. 23)
- + The breakout box is connected to the engine control unit main wiring harness with adapter **00029095016**
- + Throttle position sensor circuit A is disconnected  (p. 21)
- Throttle valve position sensor circuit A – check the signal wire for a short circuit to sensor ground.

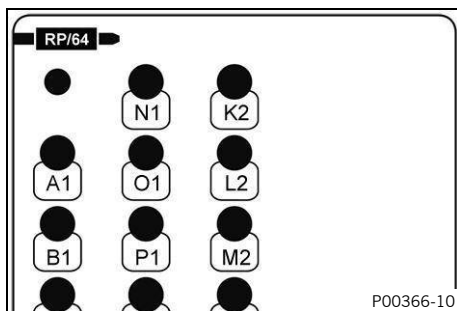

 Resistance measurement points
Bob box connector **RP** Pin **G3** – Bob box connector **RP** Pin **E2**





Resistance	$\infty \Omega$
------------	-----------------

- » Specification does not match set value
 - Check wire from Engine control unit connector **RP** (p. 218) pin **G3** to Throttle valve position sensor circuit A, connector **FT** (p. 214) pin **2** for a short circuit to sensor ground.

Last action

- Contact customer service.

3 Engine control trouble code



Blink code for malfunction indicator light	 06: Malfunction indicator light flashes 6x short
Display on diagnostic tool	P012312 «Throttle valve position sensor circuit A» «Input signal too high»
Error level condition	Throttle valve position sensor circuit A – input signal too high Voltage: ≥ 4.7 V Time: ≥ 0.08 s
Function check	Throttle valve position sensor circuit A - checking the voltage  (p. 58)
Possible cause	Throttle valve position sensor circuit A – the signal wire has a short circuit to plus (terminal 30)  (p. 58)
	Throttle valve position sensor circuit A – the signal wire has a short circuit to ignition plus (terminal 15)  (p. 59)
	Throttle valve position sensor circuit A – the signal wire has a short circuit to the sensor power supply  (p. 59)
Last action	– Contact customer service.

Throttle valve position sensor circuit A - checking the voltage

Condition



- + Diagnostic tool is connected and active
- Select «Engine control unit» > «Measured values» > «Throttle position sensor voltage» and «Throttle valve position».
- Slowly and evenly turn the throttle grip all the way.

Circuit A throttle valve position sensor	0.42 V ... 4.6 V
Circuit A throttle valve position sensor	1.5° ... 84.5° (0.026 rad ... 1.475 rad)

- » If the displayed value is equal to the set value:
 - Clear fault memory with diagnostic tool.
 - Take a test ride.
 - Read out the fault memory using the diagnostics tool.
- » If the displayed value is above the setpoint value:
 - Throttle valve position sensor circuit A – the signal wire has a short circuit to plus (terminal 30)  (p. 58)
 - Throttle valve position sensor circuit A – the signal wire has a short circuit to ignition plus (terminal 15)  (p. 59)
 - Throttle valve position sensor circuit A – the signal wire has a short circuit to the sensor power supply  (p. 59)

Throttle valve position sensor circuit A – the signal wire has a short circuit to plus (terminal 30)

Condition

- + Diagnostic tool is disconnected
- + Engine control unit is disconnected  (p. 23)
- + The breakout box is connected to the engine control unit main wiring harness with adapter **00029095016**
- + Throttle position sensor circuit A is disconnected  (p. 21)
- Throttle valve position sensor circuit A – check the signal wire for a short circuit to plus (terminal 30).

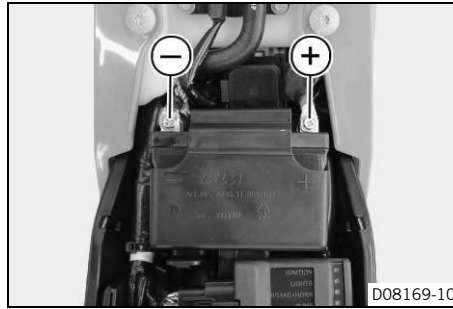
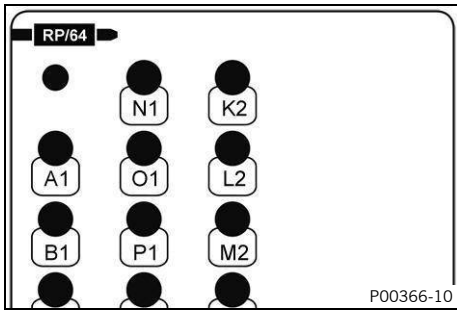

V Voltage measurement points
 Bob box connector **RP** Pin **G3** – Measuring point **Ground (-)**

Voltage	≤ 0.1 V
---------	---------

- » Specification does not match set value
 - Check wire from Engine control unit connector **RP** (p. 218) pin **G3** to Throttle valve position sensor circuit A, connector **FT** (p. 214) pin **2** for a short circuit to plus (clamp 30).
- » If the specifications have been met:
 - Check the next possible cause
 Throttle valve position sensor circuit A – the signal wire has a short circuit to ignition plus (terminal 15)

Throttle valve position sensor circuit A – the signal wire has a short circuit to ignition plus (terminal 15)

Condition

- + Diagnostic tool is disconnected
- + Engine control unit is disconnected (p. 23)
- + The breakout box is connected to the engine control unit main wiring harness with adapter **00029095016**
- + Throttle position sensor circuit A is disconnected (p. 21)
- Throttle valve position sensor circuit A – check the signal wire for a short circuit to ignition plus (terminal 15).

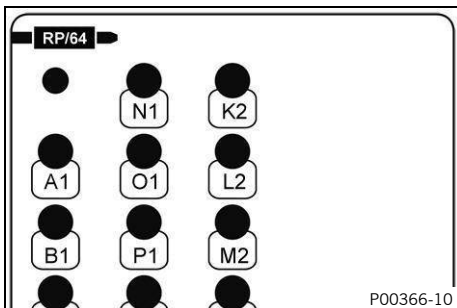

Ω Resistance measurement points
 Bob box connector **RP** Pin **G3** – Bob box connector **RP** Pin **D4**

Resistance	∞ Ω
------------	-----



- » Specification does not match set value
 - Check wire from Engine control unit connector **RP** (p. 218) pin **G3** to Throttle valve position sensor circuit A, connector **FT** (p. 214) pin **2** for a short circuit to ignition plus (clamp 15).
- » If the specifications have been met:
 - Check the next possible cause
 Throttle valve position sensor circuit A – the signal wire has a short circuit to the sensor power supply

Throttle valve position sensor circuit A – the signal wire has a short circuit to the sensor power supply

Condition

- + Diagnostic tool is disconnected

3 Engine control trouble code

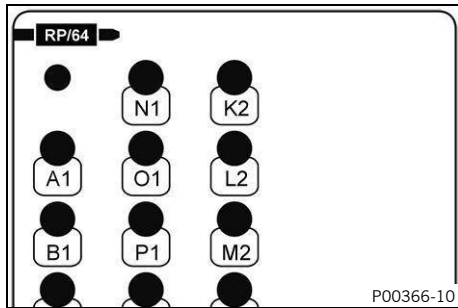

- + Engine control unit is disconnected  (p. 23)
- + The breakout box is connected to the engine control unit main wiring harness with adapter **00029095016**
- + Throttle position sensor circuit A is disconnected  (p. 21)
- Throttle valve position sensor circuit A – check the signal wire for a short circuit to the sensor power supply.



Resistance measurement points







Bob box connector **RP** Pin **G3** – Bob box connector **RP** Pin **D2**

Resistance	$\infty \Omega$
------------	-----------------

- » Specification does not match set value
 - Check wire from Engine control unit connector **RP**  (p. 218) pin **G3** to Throttle valve position sensor circuit A, connector **FT**  (p. 214) pin **2** for a short circuit to the sensor voltage supply.

Last action

- Contact customer service.

Blink code for malfunction indicator light	 17: Malfunction indicator light flashes 1x long, 7x short
Display on diagnostic tool	P013100 «Oxygen sensor» «Input signal too low»
Error level condition	Lambda sensor - input signal too low Time: ≥ 0.1 s Voltage: ≤ 0.05 V
Possible cause	Lambda sensor – the value is not plausible  (p. 61)
	Lambda sensor – the ground wire is faulty  (p. 61)
	Lambda sensor – signal wire is faulty  (p. 62)
	Lambda sensor – the signal wire has a short circuit to ground (terminal 31)  (p. 63)
	Lambda sensor – the signal wire has a short circuit to sensor ground  (p. 63)
Last action	– Contact customer service.

Lambda sensor – the value is not plausible

Condition

- + Diagnostic tool is connected and active
- + Engine is running at a higher idle speed
- + Oxygen sensor is at operating temperature
- + Oxygen sensor is connected  (p. 13)
- Lambda sensor – check the voltage.

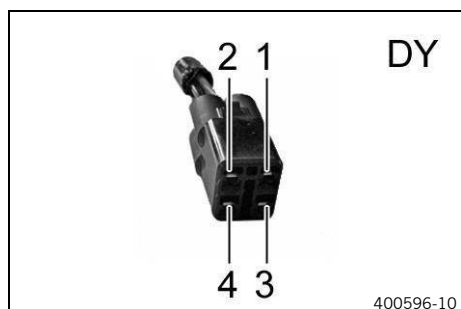



V Voltage measurement points
 Lambda sensor connector **DY** Pin 1 – Lambda sensor
 connector **DY** Pin 2

Oxygen sensor	0.2 V ... 0.8 V
---------------	-----------------

- » Specification does not match set value
 - Change the lambda sensor.
- » If the specifications have been met:
 - Check the next possible cause
 Lambda sensor – the ground wire is faulty

Lambda sensor – the ground wire is faulty

Condition

- + Diagnostic tool is disconnected
- + Engine control unit is disconnected  (p. 23)
- + The breakout box is connected to the engine control unit main wiring harness with adapter **00029095016**
- + Oxygen sensor is disconnected  (p. 13)
- + Coolant temperature sensor is disconnected  (p. 14)



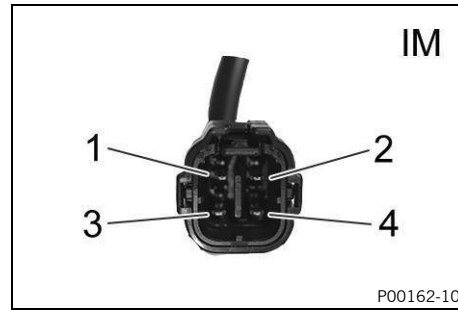
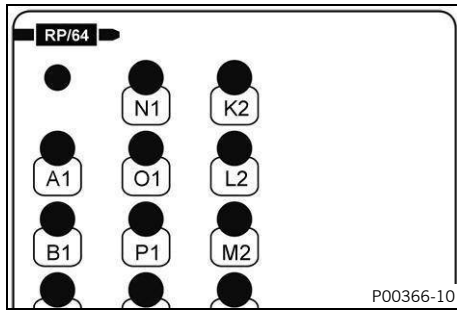

3 Engine control trouble code

- + Intake air temperature sensor is disconnected  (p. 19)
- Lambda sensor – check the ground wire.





 Resistance measurement points
Bob box connector **RP** Pin **J2** – Lambda sensor connector **IM** Pin **1**

Resistance	$\leq 0.6 \Omega$
------------	-------------------

- » Specification does not match set value
 - Check Engine control unit connector **RP**  (p. 218) pin **J2** and Lambda sensor connector **IM**  (p. 216) pin **1**.
 - Check wire from Engine control unit connector **RP**  (p. 218) pin **J2** to Lambda sensor connector **IM**  (p. 216) pin **1**.
- » If the specifications have been met:
 - Check the next possible cause
Lambda sensor – signal wire is faulty

Lambda sensor – signal wire is faulty



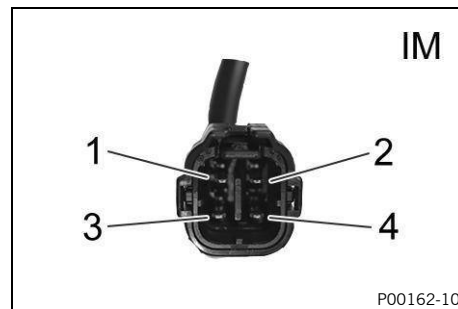
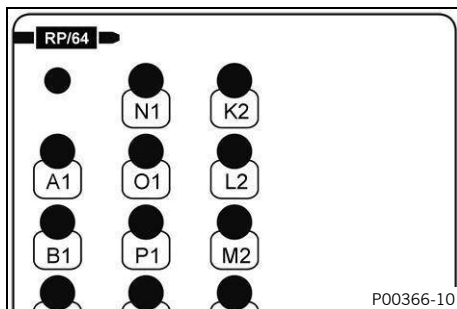

Condition

- + Diagnostic tool is disconnected
- + Engine control unit is disconnected  (p. 23)
- + The breakout box is connected to the engine control unit main wiring harness with adapter **00029095016**
- + Oxygen sensor is disconnected  (p. 13)
- Lambda sensor – check the signal wire.



 Resistance measurement points
Bob box connector **RP** Pin **H1** – Lambda sensor connector **IM** Pin **2**



Resistance	$\leq 0.6 \Omega$
------------	-------------------

- » Specification does not match set value
 - Check Engine control unit connector **RP**  (p. 218) pin **H1** and Lambda sensor connector **IM**  (p. 216) pin **2**.
 - Check wire from Engine control unit connector **RP**  (p. 218) pin **H1** to Lambda sensor connector **IM**  (p. 216) pin **2**.

- » If the specifications have been met:
 - Check the next possible cause
 - Lambda sensor – the signal wire has a short circuit to ground (terminal 31)

Lambda sensor – the signal wire has a short circuit to ground (terminal 31)

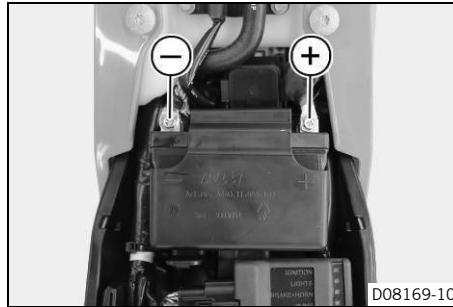
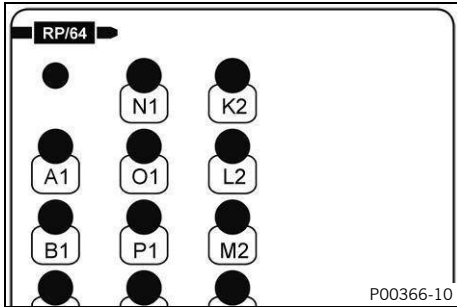

Condition

- + Diagnostic tool is disconnected
- + Engine control unit is disconnected  (p. 23)
- + The breakout box is connected to the engine control unit main wiring harness with adapter **00029095016**
- + Oxygen sensor is disconnected  (p. 13)
- Lambda sensor – check the signal wire for a short circuit to ground (terminal 31).





 Resistance measurement points
Bob box connector **RP** Pin **H1** – Measuring point **Ground (-)**

Resistance	$\infty \Omega$
------------	-----------------

- » Specification does not match set value
 - Check wire from Engine control unit connector **RP**  (p. 218) pin **H1** to Lambda sensor connector **IM**  (p. 216) pin **2** for a short circuit to ground (clamp 31).
- » If the specifications have been met:
 - Check the next possible cause
 - Lambda sensor – the signal wire has a short circuit to sensor ground

Lambda sensor – the signal wire has a short circuit to sensor ground

Condition

- + Diagnostic tool is disconnected
- + Engine control unit is disconnected  (p. 23)
- + The breakout box is connected to the engine control unit main wiring harness with adapter **00029095016**
- + Oxygen sensor is disconnected  (p. 13)
- Lambda sensor – check the signal wire for a short circuit to sensor ground.

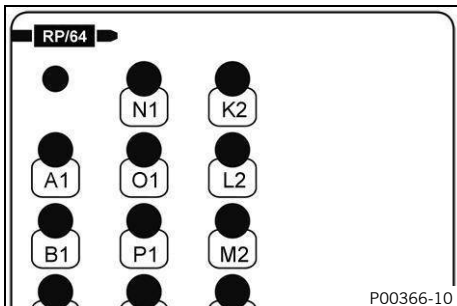

 Resistance measurement points
Bob box connector **RP** Pin **H1** – Bob box connector **RP** Pin **J2**

Resistance	$\infty \Omega$
------------	-----------------





- » Specification does not match set value

3 Engine control trouble code

- Check wire from Engine control unit connector **RP**  (p. 218) pin **H1** to Lambda sensor connector **IM**  (p. 216) pin **2** for a short circuit to sensor ground.

Last action

- Contact customer service.

Blink code for malfunction indicator light	 17: Malfunction indicator light flashes 1x long, 7x short
Display on diagnostic tool	P013200 «Oxygen sensor» «Input signal too high»
Error level condition	Lambda sensor – input signal too high Time: ≥ 0.1 s Voltage: ≥ 4 V
Possible cause	Lambda sensor – the value is not plausible  (p. 65)
	Lambda sensor – the signal wire has a short circuit to plus (terminal 30)  (p. 65)
	Lambda sensor – the signal wire has a short circuit to ignition plus (terminal 15)  (p. 66)
	Lambda sensor – the signal wire has a short circuit to the sensor power supply  (p. 66)
Last action	– Contact customer service.

Lambda sensor – the value is not plausible

Condition

- + Diagnostic tool is connected and active
- + Engine is running at a higher idle speed
- + Oxygen sensor is at operating temperature
- + Oxygen sensor is connected  (p. 13)
- Lambda sensor – check the voltage.

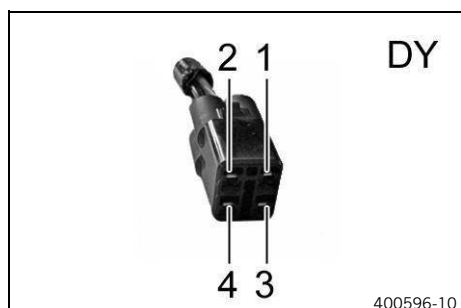

V

Voltage measurement points

Lambda sensor connector **DY** Pin 1 – Lambda sensor connector **DY** Pin 2

Oxygen sensor	0.2 V ... 0.8 V
---------------	-----------------

- » Specification does not match set value
 - Change the lambda sensor.
- » If the specifications have been met:
 - Check the next possible cause
 Lambda sensor – the signal wire has a short circuit to plus (terminal 30)

Lambda sensor – the signal wire has a short circuit to plus (terminal 30)

Condition

- + Diagnostic tool is disconnected
- + Engine control unit is disconnected  (p. 23)
- + The breakout box is connected to the engine control unit main wiring harness with adapter **00029095016**

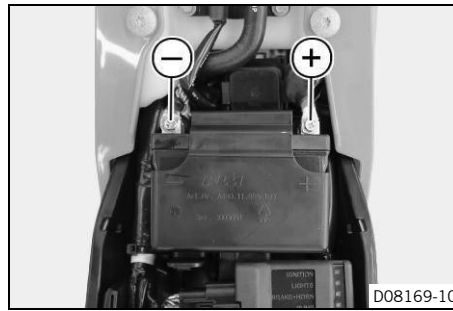
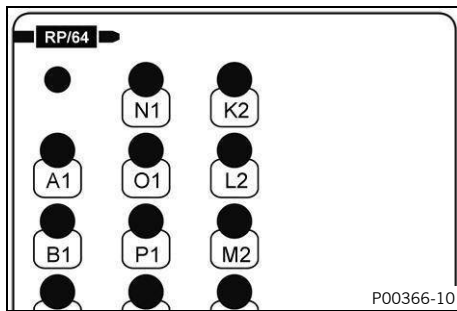

3 Engine control trouble code

- + Oxygen sensor is disconnected  (p. 13)
- Lambda sensor – check the signal wire for a short circuit to plus (terminal 30).





V Voltage measurement points
Bob box connector **RP** Pin **H1** – Measuring point **Ground (-)**

Voltage	< 0.1 V
---------	---------

- » Specification does not match set value
 - Check wire from Engine control unit connector **RP**  (p. 218) pin **H1** to Lambda sensor connector **IM**  (p. 216) pin **2** for a short circuit to plus (clamp 30).
- » If the specifications have been met:
 - Check the next possible cause
Lambda sensor – the signal wire has a short circuit to ignition plus (terminal 15)

Lambda sensor – the signal wire has a short circuit to ignition plus (terminal 15)

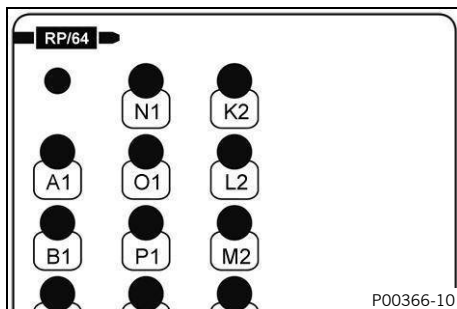

Condition

- + Diagnostic tool is disconnected
- + Engine control unit is disconnected  (p. 23)
- + The breakout box is connected to the engine control unit main wiring harness with adapter **00029095016**
- + Oxygen sensor is disconnected  (p. 13)
- Lambda sensor – check the signal wire for a short circuit to ignition plus (terminal 15).



Ω Resistance measurement points
Bob box connector **RP** Pin **H1** – Bob box connector **RP** Pin **D3**



Resistance	$\infty \Omega$
------------	-----------------

- » Specification does not match set value
 - Check wire from Engine control unit connector **RP**  (p. 218) pin **H1** to Lambda sensor connector **IM**  (p. 216) pin **2** for a short circuit to ignition plus (clamp 15).
- » If the specifications have been met:
 - Check the next possible cause
Lambda sensor – the signal wire has a short circuit to the sensor power supply

Lambda sensor – the signal wire has a short circuit to the sensor power supply

Condition

- + Diagnostic tool is disconnected

- + Engine control unit is disconnected  (p. 23)
- + The breakout box is connected to the engine control unit main wiring harness with adapter **00029095016**
- + Oxygen sensor is disconnected  (p. 13)
- Lambda sensor – check the signal wire for a short circuit to the sensor power supply.

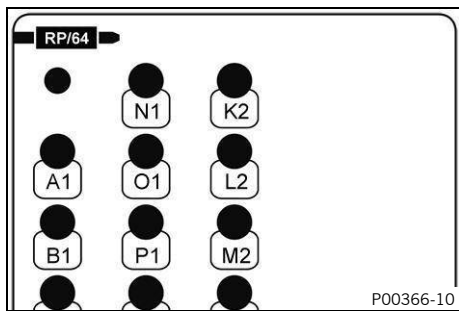

 Resistance measurement points
 Bob box connector **RP** Pin **H1** – Bob box connector **RP** Pin **D4**







Resistance	$\infty \Omega$
------------	-----------------

- » Specification does not match set value
 - Check wire from Engine control unit connector **RP**  (p. 218) pin **H1** to Lambda sensor connector **IM**  (p. 216) pin **2** for a short circuit to the sensor voltage supply.

Last action

- Contact customer service.

3 Engine control trouble code





Blink code for malfunction indicator light	 41: Malfunction indicator light flashes 4x long, 1x short
Display on diagnostic tool	P023111 «Fuel pump» «Short circuit to ground or open circuit»
Error level condition	Fuel pump - interruption/short circuit to ground The engine is switched off: ≥ 0.4 s
Function check	Checking the fuel pump  (p. 68)
Possible cause	Fuel pump – the value is not plausible  (p. 68)
	Fuel pump – the control wire is faulty  (p. 69)
	Fuel pump – supply wire resistance is too high  (p. 69)
	Fuel pump – the control wire has a short circuit to ground (terminal 31)  (p. 70)
	Fuel pump – the control wire has a short circuit to sensor ground  (p. 71)
Last action	– Contact customer service.

Checking the fuel pump

Condition

- + Diagnostic tool is connected and active
- Execute **«Engine control unit»** > **«Actuator test»** > **«Fuel pump»**.

Fuel pump	Operating noise
-----------	-----------------

- » If the specified value is reached:
 - Clear fault memory with diagnostic tool.
 - Take a test ride.
 - Read out the fault memory using the diagnostics tool.
- » If the specification is not reached:
 - Fuel pump – the value is not plausible  (p. 68)
 - Fuel pump – the control wire is faulty  (p. 69)
 - Fuel pump – supply wire resistance is too high  (p. 69)
 - Fuel pump – the control wire has a short circuit to ground (terminal 31)  (p. 70)
 - Fuel pump – the control wire has a short circuit to sensor ground  (p. 71)

Fuel pump – the value is not plausible

Condition

- + Fuel pump is disconnected  (p. 9)
- Fuel pump - check the resistance.

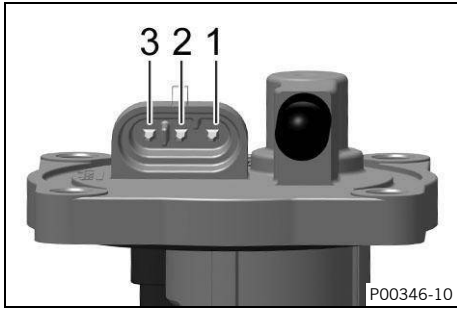

Ω Resistance measurement points
Fuel pump Pin 2 – Fuel pump Pin 3

Fuel pump	1.0 Ω ... 1.8 Ω
-----------	-------------------------------

- » Specification does not match set value
 - Change the fuel pump.
- » If the specifications have been met:
 - Check the next possible cause
Fuel pump – the control wire is faulty

Fuel pump – the control wire is faulty

Condition

- + Diagnostic tool is disconnected
- + Engine control unit is disconnected (p. 23)
- + The breakout box is connected to the engine control unit main wiring harness with adapter **00029095016**
- + Fuel pump is disconnected (p. 9)
- Fuel pump – check the control wire.

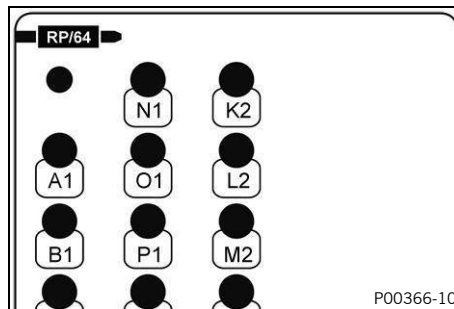
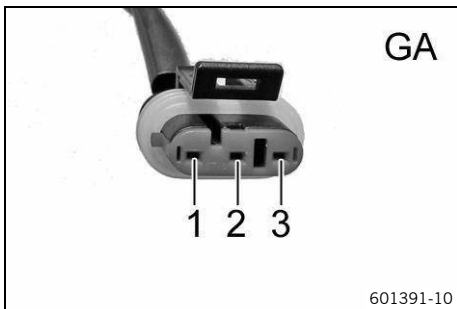

Ω Resistance measurement points
Bob box connector **RP** Pin **P3** – Fuel pump, connector **GA** Pin **2**

Resistance	$\leq 0.6 \Omega$
------------	-------------------

- » Specification does not match set value
 - Check Engine control unit connector **RP** (p. 218) pin **P3** and Fuel pump, connector **GA** (p. 214) pin **2**.
 - Check wire from Engine control unit connector **RP** (p. 218) pin **P3** to Fuel pump, connector **GA** (p. 214) pin **2**.
- » If the specifications have been met:
 - Check the next possible cause
Fuel pump – supply wire resistance is too high

Fuel pump – supply wire resistance is too high

Condition

- + Diagnostic tool is disconnected

3 Engine control trouble code

- + Fuel pump is disconnected  (p. 9)
- Fuel pump - check the load capacity of the supply wire.

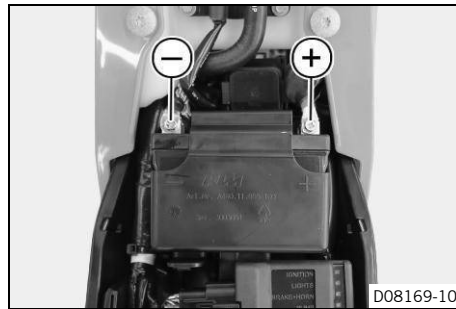
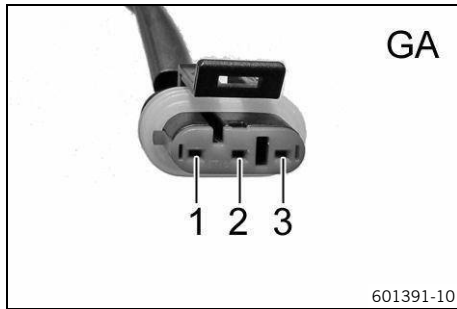

V Voltage measurement points
 Fuel pump, connector **GA** Pin **3** – Measuring point **Ground (-)**



The value must not deviate from the battery voltage «VBAT» by more than 1 V.

i **Note**
 For the measurement, the measuring points must be subjected to a 12 V/21 W bulb.

- » Specification does not match set value
 - Check the vehicle system control unit.
 - Check from Fuel pump, connector **GA**  (p. 214) pin **3** according to the wiring diagram.
- » If the specifications have been met:
 - Check the next possible cause
 Fuel pump – the control wire has a short circuit to ground (terminal 31)

Fuel pump – the control wire has a short circuit to ground (terminal 31)

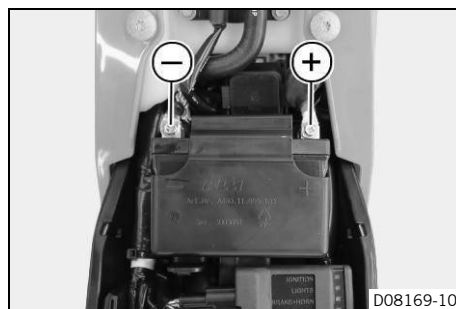
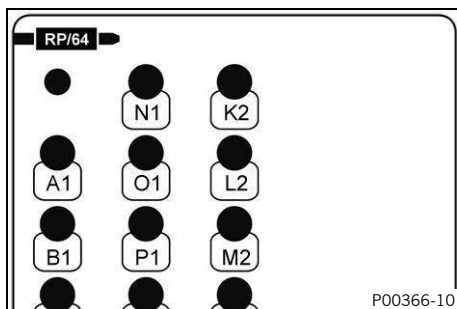

Condition

- + Diagnostic tool is disconnected
- + Engine control unit is disconnected  (p. 23)
- + The breakout box is connected to the engine control unit main wiring harness with adapter **00029095016**
- + Fuel pump is disconnected  (p. 9)
- Fuel pump – check the control wire for a short circuit to ground (terminal 31).



Ω Resistance measurement points
 Bob box connector **RP** Pin **P3** – Measuring point **Ground (-)**



Resistance	∞ Ω
------------	-----

- » Specification does not match set value
 - Check wire from Engine control unit connector **RP**  (p. 218) pin **P3** to Fuel pump, connector **GA**  (p. 214) pin **2** for a short circuit to ground (clamp 31).

- » If the specifications have been met:
 - Check the next possible cause
 - Fuel pump – the control wire has a short circuit to sensor ground

Fuel pump – the control wire has a short circuit to sensor ground

Condition

- + Diagnostic tool is disconnected
- + Engine control unit is disconnected  (p. 23)
- + The breakout box is connected to the engine control unit main wiring harness with adapter **00029095016**
- + Fuel pump is disconnected  (p. 9)
- Fuel pump – check the control wire for a short circuit to sensor ground.

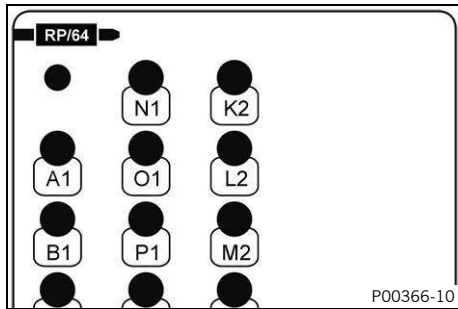

 Resistance measurement points
 Bob box connector **RP** Pin **P3** – Bob box connector **RP** Pin **E2**



Resistance	$\infty \Omega$
------------	-----------------

- » Specification does not match set value
 - Check wire from Engine control unit connector **RP**  (p. 218) pin **P3** to Fuel pump, connector **GA**  (p. 214) pin **2** for a short circuit to sensor ground.

Last action

- Contact customer service.

3 Engine control trouble code

Blink code for malfunction indicator light	 41: Malfunction indicator light flashes 4x long, 1x short
Display on diagnostic tool	P023212 «Fuel pump» «Short circuit to plus»
Error level condition	Fuel pump - short circuit to plus The engine is switched off: ≥ 0.4 s
Function check	Checking the fuel pump  (p. 72)
Possible cause	Fuel pump – the control wire has a short circuit to plus (terminal 30)  (p. 72)
Last action	– Contact customer service.

Checking the fuel pump

Condition



- + Diagnostic tool is connected and active
- Execute «**Engine control unit**» > «**Actuator test**» > «**Fuel pump**».

Fuel pump	Operating noise
-----------	-----------------

- » If the specified value is reached:
 - Clear fault memory with diagnostic tool.
 - Take a test ride.
 - Read out the fault memory using the diagnostics tool.
- » If the specification is not reached:
Fuel pump – the control wire has a short circuit to plus (terminal 30)  (p. 72)

Fuel pump – the control wire has a short circuit to plus (terminal 30)

Condition

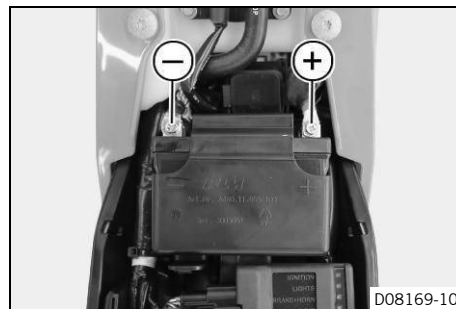
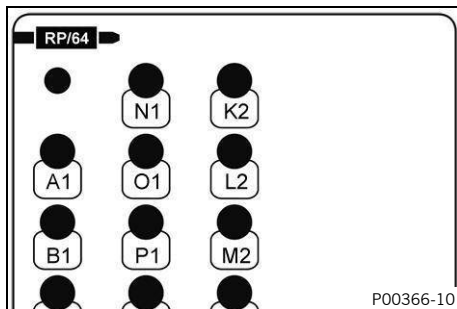

- + Diagnostic tool is disconnected
- + Engine control unit is disconnected  (p. 23)
- + The breakout box is connected to the engine control unit main wiring harness with adapter **00029095016**
- + Fuel pump is disconnected  (p. 9)
- Fuel pump – check the control wire for a short circuit to plus (terminal 30).



 Resistance measurement points
Bob box connector **RP** Pin **P3** – Measuring point **Plus (+)**

Resistance	$\infty \Omega$
------------	-----------------







- » Specification does not match set value

- Check wire from Engine control unit connector **RP**  (p. 218) pin **P3** to Fuel pump, connector **GA**  (p. 214) pin **2** for a short circuit to ground (clamp 31).

Last action

- Contact customer service.

3 Engine control trouble code





Blink code for malfunction indicator light	 33: Malfunction indicator lamp flashes 3x long, 3x short
Display on diagnostic tool	P026111 «Injection valve 1, cylinder 1» «Input signal too low»
Error level condition	Injector 1, cylinder 1 - input signal too low Time: ≥ 1 s
Function check	Injector 1, cylinder 1 – checking actuation  (p. 74)
Possible cause	Injection valve 1, cylinder 1 – the value is not plausible  (p. 74)
	Injection valve 1, cylinder 1 – the power supply is faulty  (p. 75)
	Injection valve 1, cylinder 1 – the control wire is faulty  (p. 76)
	Injection valve 1, cylinder 1 – the control wire has a short circuit to ground (terminal 31)  (p. 76)
	Injection valve 1, cylinder 1 – the control wire has a short circuit to sensor ground  (p. 77)
Last action	– Contact customer service.

Injector 1, cylinder 1 – checking actuation

Condition

- + Diagnostic tool is connected and active
- Execute «**Engine control unit**» > «**Actuator test**» > «**Injection valve 1**».

Injector	Operating noise
----------	-----------------

- » If the specified value is reached:
 - Clear fault memory with diagnostic tool.
 - Take a test ride.
 - Read out the fault memory using the diagnostics tool.
- » If the specification is not reached:
 - Injection valve 1, cylinder 1 – the value is not plausible  (p. 74)
 - Injection valve 1, cylinder 1 – the power supply is faulty  (p. 75)
 - Injection valve 1, cylinder 1 – the control wire is faulty  (p. 76)
 - Injection valve 1, cylinder 1 – the control wire has a short circuit to ground (terminal 31)  (p. 76)
 - Injection valve 1, cylinder 1 – the control wire has a short circuit to sensor ground  (p. 77)

Injection valve 1, cylinder 1 – the value is not plausible

Condition

- + Injector 1, cylinder 1 is disconnected  (p. 20)
- Injection valve 1, cylinder 1 – check the resistance.

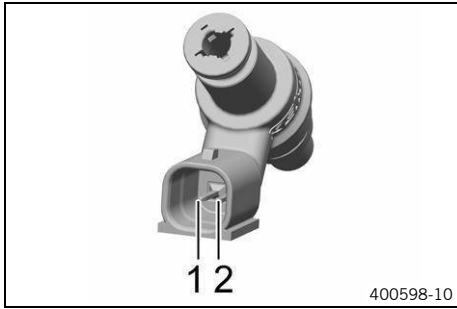



Ω Resistance measurement points
 Injection valves, cylinder 1 Pin 1 – Injection valves, cylinder 1 Pin 2

Injector	
Resistance at: 20 °C (68.0 °F)	11.4 Ω ... 12.6 Ω

- » Specification does not match set value
 - Change the injector.
- » If the specifications have been met:
 - Check the next possible cause
 Injection valve 1, cylinder 1 – the power supply is faulty

Injection valve 1, cylinder 1 – the power supply is faulty

Condition

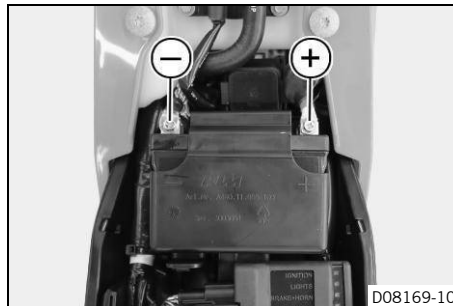
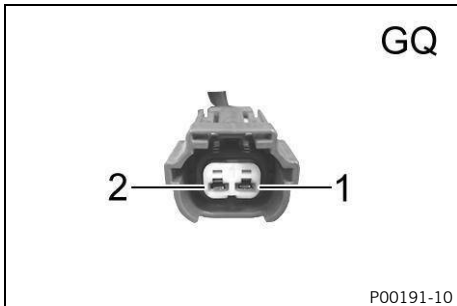

- + Diagnostic tool is connected and active
- + Engine control unit is connected  (p. 23)
- + Injector 1, cylinder 1 is disconnected  (p. 20)
- Injector 1, cylinder 1 – check the voltage supply



V Voltage measurement points
 Injector 1, cylinder 1, socket connector **GQ** Pin 2 – Measuring point **Ground (-)**

The value must not deviate from the battery voltage «**VBAT**» by more than 1 V.



i Note
 For the measurement, the measuring points must be subjected to a 12 V/21 W bulb.

- » Specification does not match set value
 - Check Injector 1, cylinder 1, socket connector **GQ**  (p. 215) pin 2.
 - Check wire from Injector 1, cylinder 1, socket connector **GQ**  (p. 215) pin 2 to the next node in the wiring harness.
- » If the specifications have been met:
 - Check the next possible cause
 Injection valve 1, cylinder 1 – the control wire is faulty

3 Engine control trouble code

Injection valve 1, cylinder 1 – the control wire is faulty

Condition



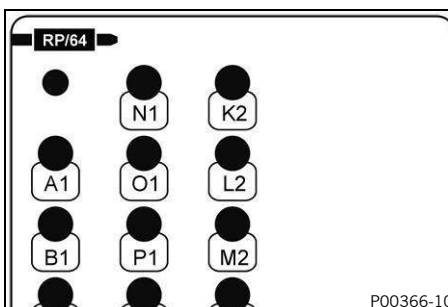
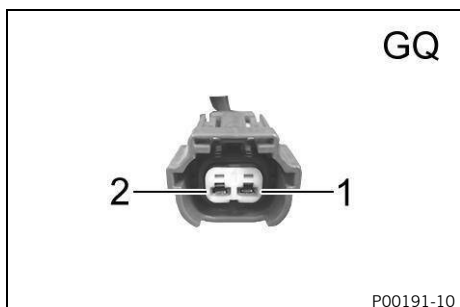

- + Diagnostic tool is disconnected
- + Engine control unit is disconnected  (p. 23)
- + The breakout box is connected to the engine control unit main wiring harness with adapter **00029095016**
- + Injector 1, cylinder 1 is disconnected  (p. 20)
- Injection valve 1, cylinder 1 – check the control wire.



Resistance measurement points



Bob box connector **RP** Pin **N4** – Injector 1, cylinder 1, socket connector **GQ** Pin **1**

Resistance	$\leq 0.6 \Omega$
------------	-------------------

- » Specification does not match set value
 - Check Engine control unit connector **RP**  (p. 218) pin **N4** and Injector 1, cylinder 1, socket connector **GQ**  (p. 215) pin **1**.
 - Check wire from Engine control unit connector **RP**  (p. 218) pin **N4** to Injector 1, cylinder 1, socket connector **GQ**  (p. 215) pin **1**.
- » If the specifications have been met:
 - Check the next possible cause
Injection valve 1, cylinder 1 – the control wire has a short circuit to ground (terminal 31)

Injection valve 1, cylinder 1 – the control wire has a short circuit to ground (terminal 31)

Condition

- + Diagnostic tool is disconnected
- + Engine control unit is disconnected  (p. 23)
- + The breakout box is connected to the engine control unit main wiring harness with adapter **00029095016**
- + Injector 1, cylinder 1 is disconnected  (p. 20)
- Injector 1, cylinder 1 – check the control wire for a short circuit to ground (clamp 31)

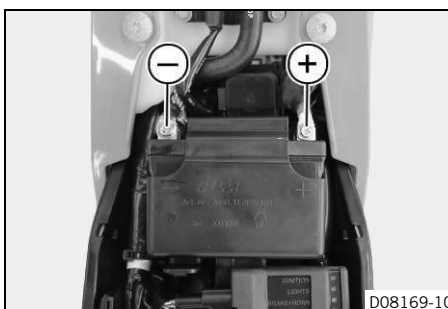
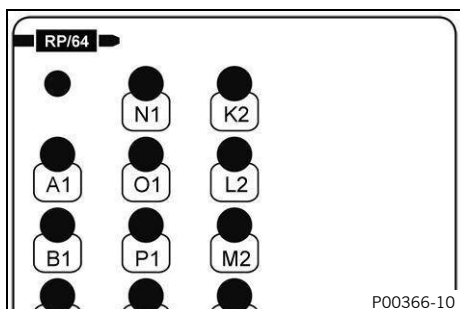

Resistance measurement points

Bob box connector **RP** Pin **N4** – Measuring point **Ground (-)**

Resistance	$\infty \Omega$
------------	-----------------

- » Specification does not match set value
 - Check wire from Engine control unit connector **RP** (p. 218) pin **N4** to Injector 1, cylinder 1, socket connector **GQ** (p. 215) pin **1** for a short circuit to ground (clamp 31).
- » If the specifications have been met:
 - Check the next possible cause
 - Injection valve 1, cylinder 1 – the control wire has a short circuit to sensor ground

Injection valve 1, cylinder 1 – the control wire has a short circuit to sensor ground

Condition

- + Diagnostic tool is disconnected
- + Engine control unit is disconnected (p. 23)
- + The breakout box is connected to the engine control unit main wiring harness with adapter **00029095016**
- + Injector 1, cylinder 1 is disconnected (p. 20)
- Injection valve 1, cylinder 1 – check the control wire for a short circuit to sensor ground.

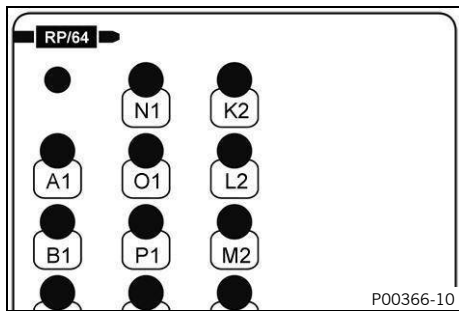

Ω Resistance measurement points
Bob box connector **RP** Pin **N4** – Bob box connector **RP** Pin **E2**







Resistance	$\infty \Omega$
------------	-----------------

- » Specification does not match set value
 - Check wire from Engine control unit connector **RP** (p. 218) pin **N4** to Injector 1, cylinder 1, socket connector **GQ** (p. 215) pin **1** for a short circuit to sensor ground.

Last action

- Contact customer service.

3 Engine control trouble code





Blink code for malfunction indicator light	 33: Malfunction indicator lamp flashes 3x long, 3x short
Display on diagnostic tool	P026212 «Injection valve 1, cylinder 1» «Input signal too high»
Error level condition	Injector 1, cylinder 1 - input signal too high Time: ≥ 1 s
Function check	Injector 1, cylinder 1 – checking actuation  (p. 78)
Possible cause	Injector valve 1, cylinder 1 – the value is not plausible  (p. 78)
	Injector valve 1, cylinder 1 – the control wire has a short circuit to plus (terminal 30)  (p. 79)
	Injector valve 1, cylinder 1 – the control wire has a short circuit to ignition plus (terminal 15)  (p. 79)
	Injector valve 1, cylinder 1 – the control wire has a short circuit to the sensor power supply  (p. 80)
Last action	– Contact customer service.

Injector 1, cylinder 1 – checking actuation

Condition

- + Diagnostic tool is connected and active
- Execute «**Engine control unit**» > «**Actuator test**» > «**Injection valve 1**».

Injector	Operating noise
----------	-----------------

- » If the specified value is reached:
 - Clear fault memory with diagnostic tool.
 - Take a test ride.
 - Read out the fault memory using the diagnostics tool.
- » If the specification is not reached:
 - Injector valve 1, cylinder 1 – the value is not plausible  (p. 78)
 - Injector valve 1, cylinder 1 – the control wire has a short circuit to plus (terminal 30)  (p. 79)
 - Injector valve 1, cylinder 1 – the control wire has a short circuit to ignition plus (terminal 15)  (p. 79)
 - Injector valve 1, cylinder 1 – the control wire has a short circuit to the sensor power supply  (p. 80)

Injector valve 1, cylinder 1 – the value is not plausible

Condition

- + Injector 1, cylinder 1 is disconnected  (p. 20)
- Injector valve 1, cylinder 1 – check the resistance.

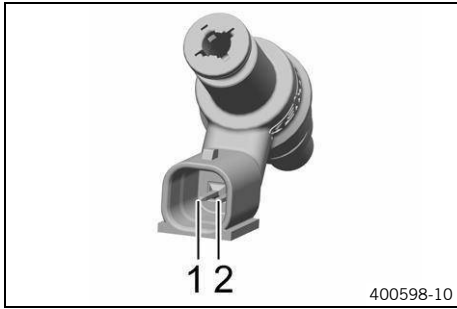

Ω Resistance measurement points
 Injection valves, cylinder 1 Pin 1 – Injection valves, cylinder 1 Pin 2

Injector	
Resistance at: 20 °C (68.0 °F)	11.4 Ω ... 12.6 Ω

- » Specification does not match set value
 - Change the injector.
- » If the specifications have been met:
 - Check the next possible cause
 Injection valve 1, cylinder 1 – the control wire has a short circuit to plus (terminal 30)

Injection valve 1, cylinder 1 – the control wire has a short circuit to plus (terminal 30)

Condition

- + Diagnostic tool is disconnected
- + Engine control unit is disconnected (p. 23)
- + The breakout box is connected to the engine control unit main wiring harness with adapter **00029095016**
- + Injector 1, cylinder 1 is disconnected (p. 20)
- Injector 1, cylinder 1 – check the control wire for a short circuit to plus (clamp 30)

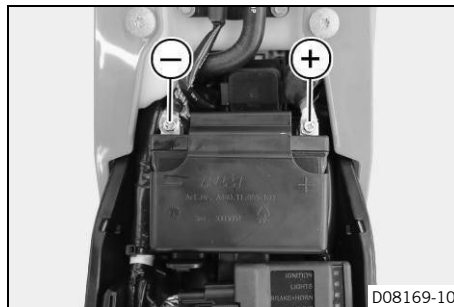
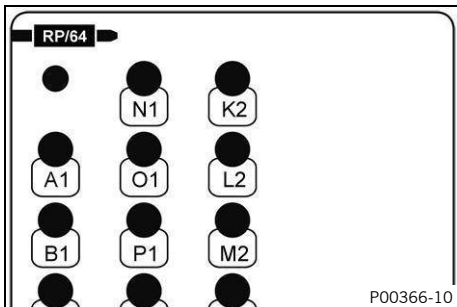

V Voltage measurement points
 Bob box connector **RP** Pin **N4** – Measuring point **Ground (-)**

Voltage	< 0.1 V
---------	---------

- » Specification does not match set value
 - Check wire from Engine control unit connector **RP** (p. 218) pin **N4** to Injector 1, cylinder 1, socket connector **GQ** (p. 215) pin **1** for a short circuit to plus (clamp 30).
- » If the specifications have been met:
 - Check the next possible cause
 Injection valve 1, cylinder 1 – the control wire has a short circuit to ignition plus (terminal 15)

Injection valve 1, cylinder 1 – the control wire has a short circuit to ignition plus (terminal 15)

Condition

- + Diagnostic tool is disconnected
- + Engine control unit is disconnected (p. 23)
- + The breakout box is connected to the engine control unit main wiring harness with adapter **00029095016**

3 Engine control trouble code

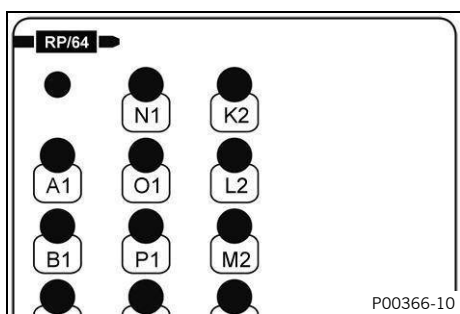

- + Injector 1, cylinder 1 is disconnected  (p. 20)
- Injection valve 1, cylinder 1 – check the control wire for a short circuit to ignition plus (terminal 15).



Resistance measurement points
Bob box connector **RP** Pin **N4** – Bob box connector **RP** Pin **D4**



Resistance

$\infty \Omega$

- » Specification does not match set value
 - Check wire from Engine control unit connector **RP**  (p. 218) pin **N4** to Injector 1, cylinder 1, socket connector **GQ**  (p. 215) pin **1** for a short circuit to ignition plus (clamp 15).
- » If the specifications have been met:
 - Check the next possible cause
Injection valve 1, cylinder 1 – the control wire has a short circuit to the sensor power supply

Injection valve 1, cylinder 1 – the control wire has a short circuit to the sensor power supply

Condition

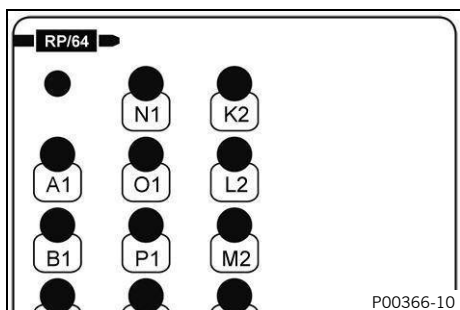

- + Diagnostic tool is disconnected
- + Engine control unit is disconnected  (p. 23)
- + The breakout box is connected to the engine control unit main wiring harness with adapter **00029095016**
- + Injector 1, cylinder 1 is disconnected  (p. 20)
- Injection valve 1, cylinder 1 – check the control wire for a short circuit to the sensor power supply.



Resistance measurement points
Bob box connector **RP** Pin **N4** – Bob box connector **RP** Pin **D3**







Resistance

$\infty \Omega$

- » Specification does not match set value
 - Check wire from Engine control unit connector **RP**  (p. 218) pin **N4** to Injector 1, cylinder 1, socket connector **GQ**  (p. 215) pin **1** for a short circuit to the sensor voltage supply.

Last action

- Contact customer service.





Blink code for malfunction indicator light	 34: Malfunction indicator lamp flashes 3x long, 4x short
Display on diagnostic tool	P026411 «Injector 2, cylinder 1» «Input signal too low»
Error level condition	Injector 2, cylinder 1 - input signal too low Time: ≥ 1 s
Function check	Injector 2, cylinder 1 – checking actuation  (p. 81)
Possible cause	Injector 2, cylinder 1 – the value is not plausible  (p. 81)
	Injector 2, cylinder 1 – the voltage supply is faulty  (p. 82)
	Injector 2, cylinder 1 – the control wire is faulty  (p. 83)
	Injection valve 2, cylinder 1 – the control wire has a short circuit to ground (terminal 31)  (p. 83)
	Injection valve 2, cylinder 1 - the control wire has a short circuit to sensor ground  (p. 84)
Last action	– Contact customer service.

Injector 2, cylinder 1 – checking actuation

Condition

- + Diagnostic tool is connected and active
- Execute «**Engine control unit**» > «**Actuator test**» > «**Injector**».

Injector	Operating noise
----------	-----------------

- » If the specified value is reached:
 - Clear fault memory with diagnostic tool.
 - Take a test ride.
 - Read out the fault memory using the diagnostics tool.
- » If the specification is not reached:
 - Injector 2, cylinder 1 – the value is not plausible  (p. 81)
 - Injector 2, cylinder 1 – the voltage supply is faulty  (p. 82)
 - Injector 2, cylinder 1 – the control wire is faulty  (p. 83)
 - Injection valve 2, cylinder 1 – the control wire has a short circuit to ground (terminal 31)  (p. 83)
 - Injection valve 2, cylinder 1 - the control wire has a short circuit to sensor ground  (p. 84)



Injector 2, cylinder 1 – the value is not plausible

Condition

- + Injector 2, cylinder 1 is disconnected  (p. 20)
- Injection valve 2, cylinder 1 – check the resistance.

3 Engine control trouble code

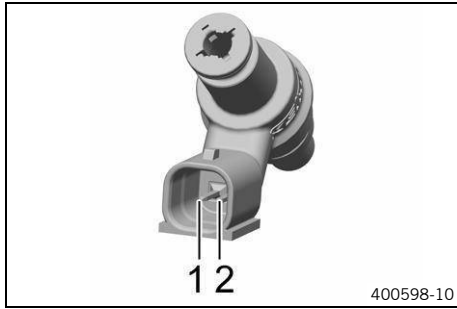

Resistance measurement points
Injection valves, cylinder 1 Pin 1 – Injection valves, cylinder 1 Pin 2

Injector	
Resistance at: 20 °C (68.0 °F)	11.4 Ω ... 12.6 Ω

- » Specification does not match set value
 - Change the injector.
- » If the specifications have been met:
 - Check the next possible cause
Injector 2, cylinder 1 – the voltage supply is faulty

Injector 2, cylinder 1 – the voltage supply is faulty

Condition

- + Diagnostic tool is connected and active
- + Engine control unit is connected (p. 23)
- + Injector 2, cylinder 1 is disconnected (p. 20)
- Injector 2, cylinder 1 – check the voltage supply

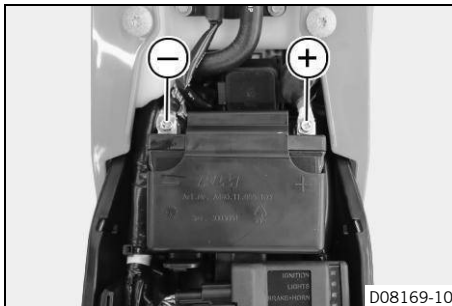
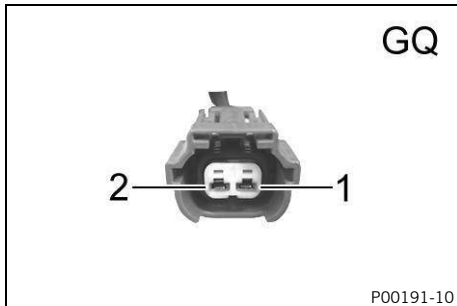

Voltage measurement points
Injection valve 2, cylinder 1, connector **GQ** Pin 2 – Measuring point **Ground (-)**

The value must not deviate from the battery voltage «VBAT» by more than 1 V.





Note

For the measurement, the measuring points must be subjected to a 12 V/21 W bulb.

- » Specification does not match set value
 - Check Injection valve 2, cylinder 1, connector **GQ** (p. 215) pin 2.
 - Check wire from Injection valve 2, cylinder 1, connector **GQ** (p. 215) pin 2 to the next node in the wiring harness.
- » If the specifications have been met:
 - Check the next possible cause
Injector 2, cylinder 1 – the control wire is faulty

Injector 2, cylinder 1 – the control wire is faulty

Condition



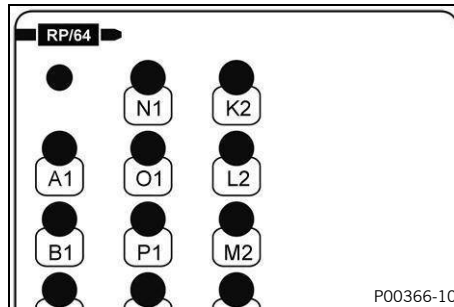
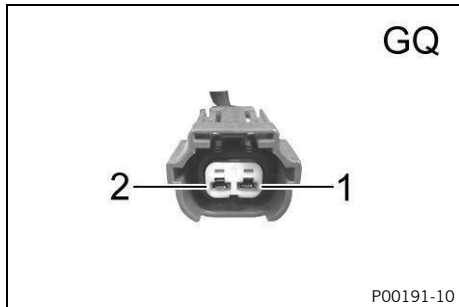

- + Diagnostic tool is disconnected
- + Engine control unit is disconnected  (p. 23)
- + The breakout box is connected to the engine control unit main wiring harness with adapter **00029095016**
- + Injector 2, cylinder 1 is disconnected  (p. 20)
- Injector 2, cylinder 1 – check the control wire



Resistance measurement points



Bob box connector **RP** Pin **M3** – Injection valve 2, cylinder 1, connector **GQ** Pin **1**

Resistance	≤ 0.6 Ω
------------	---------

- » Specification does not match set value
 - Check Engine control unit connector **RP**  (p. 218) pin **M3** and Injection valve 2, cylinder 1, connector **GQ**  (p. 215) pin **1**.
 - Check wire from Engine control unit connector **RP**  (p. 218) pin **M3** to Injection valve 2, cylinder 1, connector **GQ**  (p. 215) pin **1**.
- » If the specifications have been met:
 - Check the next possible cause
Injection valve 2, cylinder 1 – the control wire has a short circuit to ground (terminal 31)

Injection valve 2, cylinder 1 – the control wire has a short circuit to ground (terminal 31)

Condition

- + Diagnostic tool is disconnected
- + Engine control unit is disconnected  (p. 23)
- + The breakout box is connected to the engine control unit main wiring harness with adapter **00029095016**
- + Injector 2, cylinder 1 is disconnected  (p. 20)
- Injector 2, cylinder 1 – check the control wire for a short circuit to ground (clamp 31)

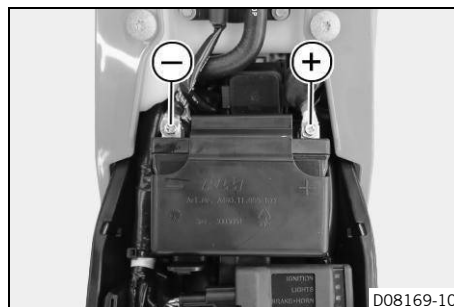
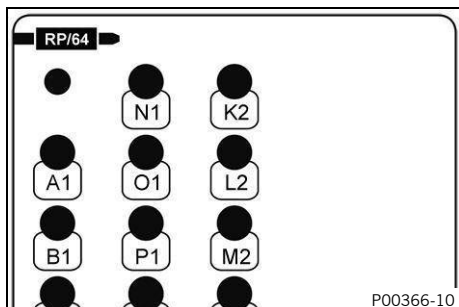

Resistance measurement points

Bob box connector **RP** Pin **M3** – Measuring point **Ground (-)**

3 Engine control trouble code

Resistance	$\infty \Omega$
------------	-----------------

- » Specification does not match set value
 - Check wire from Engine control unit connector **RP** (p. 218) pin **M3** to Injection valve 2, cylinder 1, connector **GQ** (p. 215) pin **1** for a short circuit to ground (clamp 31).
- » If the specifications have been met:
 - Check the next possible cause
 - Injection valve 2, cylinder 1 - the control wire has a short circuit to sensor ground

Injection valve 2, cylinder 1 - the control wire has a short circuit to sensor ground

Condition

- + Diagnostic tool is disconnected
- + Engine control unit is disconnected (p. 23)
- + The breakout box is connected to the engine control unit main wiring harness with adapter **00029095016**
- + Injector 2, cylinder 1 is disconnected (p. 20)
- Injection valve 2, cylinder 1 – check the control wire for a short circuit to sensor ground.

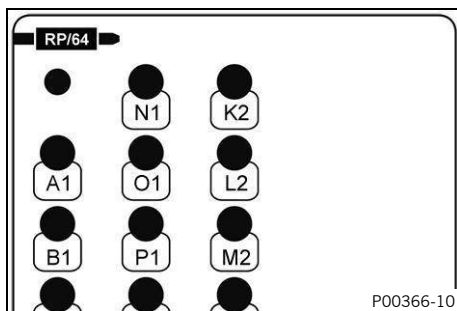

Resistance measurement points







Bob box connector **RP** Pin **M3** – Bob box connector **RP** Pin **E2**

Resistance	$\infty \Omega$
------------	-----------------

- » Specification does not match set value
 - Check wire from Engine control unit connector **RP** (p. 218) pin **M3** to Injection valve 2, cylinder 1, connector **GQ** (p. 215) pin **1** for a short circuit to sensor ground.

Last action

- Contact customer service.





Blink code for malfunction indicator light	 34: Malfunction indicator lamp flashes 3x long, 4x short
Display on diagnostic tool	P026512 «Injector 2, cylinder 1» «Input signal too high»
Error level condition	Injector 2, cylinder 1 - input signal too high Time: ≥ 1 s
Function check	Injector 2, cylinder 1 – checking actuation  (p. 85)
Possible cause	Injector 2, cylinder 1 – the value is not plausible  (p. 85)
	Injection valve 2, cylinder 1 – the control wire has a short circuit to plus (terminal 30)  (p. 86)
	Injection valve 2, cylinder 1 – the control wire has a short circuit to ignition plus (terminal 15)  (p. 86)
	Injection valve 2, cylinder 1 – the control wire has a short circuit to the sensor power supply  (p. 87)
Last action	– Contact customer service.

Injector 2, cylinder 1 – checking actuation

Condition

- + Diagnostic tool is connected and active
- Execute «Engine control unit» > «Actuator test» > «Injector».

Injector	Operating noise
----------	-----------------

- » If the specified value is reached:
 - Clear fault memory with diagnostic tool.
 - Take a test ride.
 - Read out the fault memory using the diagnostics tool.
- » If the specification is not reached:
 - Injector 2, cylinder 1 – the value is not plausible  (p. 85)
 - Injection valve 2, cylinder 1 – the control wire has a short circuit to plus (terminal 30)  (p. 86)
 - Injection valve 2, cylinder 1 – the control wire has a short circuit to ignition plus (terminal 15)  (p. 86)
 - Injection valve 2, cylinder 1 – the control wire has a short circuit to the sensor power supply  (p. 87)

Injector 2, cylinder 1 – the value is not plausible

Condition

- + Injector 2, cylinder 1 is disconnected  (p. 20)
- Injection valve 2, cylinder 1 – check the resistance.

3 Engine control trouble code



Resistance measurement points
Injection valves, cylinder 1 Pin 1 – Injection valves,
cylinder 1 Pin 2

Injector	
Resistance at: 20 °C (68.0 °F)	11.4 Ω ... 12.6 Ω

- » Specification does not match set value
 - Change the injector.
- » If the specifications have been met:
 - Check the next possible cause
Injection valve 2, cylinder 1 – the control wire has a short circuit to plus (terminal 30)

Injection valve 2, cylinder 1 – the control wire has a short circuit to plus (terminal 30)

Condition

- + Diagnostic tool is disconnected
- + Engine control unit is disconnected (p. 23)
- + The breakout box is connected to the engine control unit main wiring harness with adapter **00029095016**
- + Injector 2, cylinder 1 is disconnected (p. 20)
- Injection valve 2, cylinder 1 – check the control wire for a short circuit to plus (terminal 30).

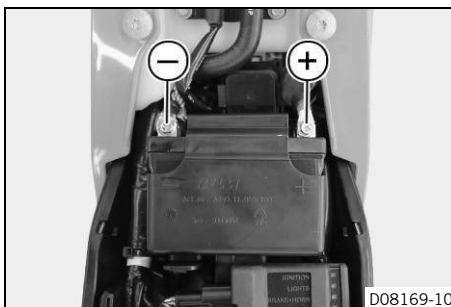
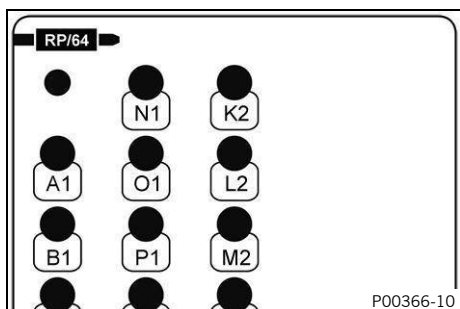

Voltage measurement points
Bob box connector **RP** Pin **M3** – Measuring point **Ground (-)**

Voltage	< 0.1 V
---------	---------

- » Specification does not match set value
 - Check wire from Engine control unit connector **RP** (p. 218) pin **M3** to Injection valve 2, cylinder 1, connector **GQ** (p. 215) pin **1** for a short circuit to plus (clamp 30).
- » If the specifications have been met:
 - Check the next possible cause
Injection valve 2, cylinder 1 – the control wire has a short circuit to ignition plus (terminal 15)

Injection valve 2, cylinder 1 – the control wire has a short circuit to ignition plus (terminal 15)

Condition

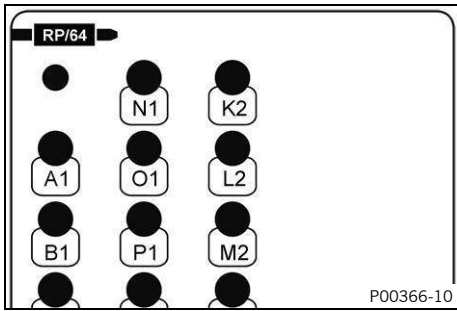

- + Diagnostic tool is disconnected
- + Engine control unit is disconnected (p. 23)
- + The breakout box is connected to the engine control unit main wiring harness with adapter **00029095016**

- + Injector 2, cylinder 1 is disconnected  (p. 20)
- Injection valve 2, cylinder 1 – check the control wire for a short circuit to ignition plus (terminal 15).





 Resistance measurement points
 Bob box connector **RP** Pin **M3** – Bob box connector **RP** Pin **D4**

Resistance	$\infty \Omega$
------------	-----------------

- » Specification does not match set value
 - Check wire from Engine control unit connector **RP**  (p. 218) pin **M3** to Injection valve 2, cylinder 1, connector **GQ**  (p. 215) pin **1** for a short circuit to ignition plus (clamp 15).
- » If the specifications have been met:
 - Check the next possible cause
 Injection valve 2, cylinder 1 – the control wire has a short circuit to the sensor power supply

Injection valve 2, cylinder 1 – the control wire has a short circuit to the sensor power supply

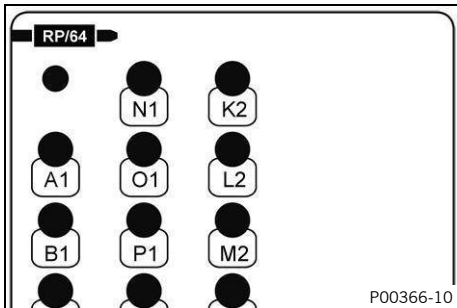

Condition

- + Diagnostic tool is disconnected
- + Engine control unit is disconnected  (p. 23)
- + The breakout box is connected to the engine control unit main wiring harness with adapter **00029095016**
- + Injector 2, cylinder 1 is disconnected  (p. 20)
- Injection valve 2, cylinder 1 – check the control wire for a short circuit to the sensor power supply.



 Resistance measurement points
 Bob box connector **RP** Pin **M3** – Bob box connector **RP** Pin **D3**







Resistance	$\infty \Omega$
------------	-----------------

- » Specification does not match set value
 - Check wire from Engine control unit connector **RP**  (p. 218) pin **M3** to Injection valve 2, cylinder 1, connector **GQ**  (p. 215) pin **1** for a short circuit to the sensor voltage supply.

Last action

- Contact customer service.

3 Engine control trouble code





Blink code for malfunction indicator light	 37: Malfunction indicator light flashes 3x long, 7x short
Display on diagnostic tool	P035100 «Ignition coil» «Circuit fault»
Error level condition	Ignition coil - failure in circuit Time: ≥ 2.0 s
Function check	Checking the ignition coil  (p. 88)
Possible cause	Ignition coil – the value is not plausible  (p. 88)
	Ignition coil – control wire is faulty  (p. 89)
	Ignition coil – the control wire has a short circuit to ground (terminal 31)  (p. 89)
	Ignition coil – control wire has a short circuit to plus (terminal 30)  (p. 90)
Last action	– Contact customer service.

Checking the ignition coil

Condition

- + Diagnostic tool is connected and active
- Execute «Engine control unit» > «Actuator test» > «Ignition coil».

Spark plug	Operating noise
------------	-----------------

- » If the specified value is reached:
 - Clear fault memory with diagnostic tool.
 - Take a test ride.
 - Read out the fault memory using the diagnostics tool.
- » If the specification is not reached:
 - Ignition coil – the value is not plausible  (p. 88)
 - Ignition coil – control wire is faulty  (p. 89)
 - Ignition coil – the control wire has a short circuit to ground (terminal 31)  (p. 89)
 - Ignition coil – control wire has a short circuit to plus (terminal 30)  (p. 90)

Ignition coil – the value is not plausible

Condition

- + Diagnostic tool is disconnected
- + Ignition coil is disconnected  (p. 16)
- Ignition coil - check the resistance.

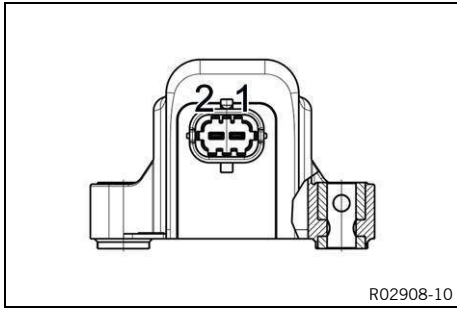

Ω Resistance measurement points
Ignition coil Pin 1 (-) – Ignition coil Pin 2 (+)

Ignition coil	0.337 Ω ... 0.412 Ω
---------------	---------------------

- » Specification does not match set value
 - Change the ignition coil.
- » If the specifications have been met:
 - Check the next possible cause
Ignition coil – control wire is faulty

Ignition coil – control wire is faulty

Condition

- + Diagnostic tool is disconnected
- + Engine control unit is disconnected (p. 23)
- + The breakout box is connected to the engine control unit main wiring harness with adapter **00029095016**
- + Ignition coil is disconnected (p. 16)
- Ignition coil - check the control wire.

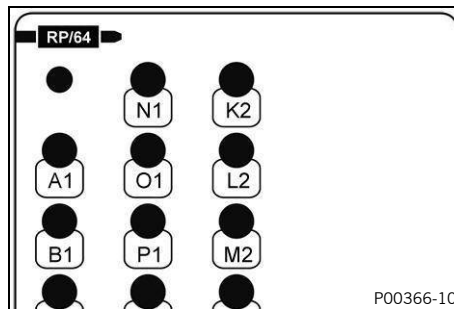
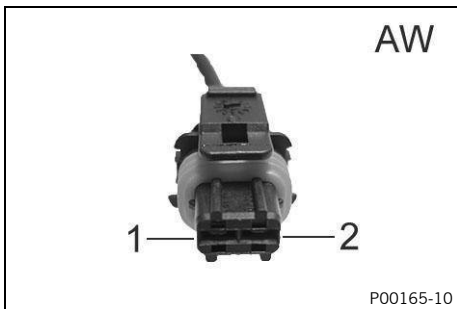

Ω Resistance measurement points
Ignition coil connector **AW** Pin 1 – Bob box connector **RP** Pin **Q3**

Resistance	0.6 Ω
------------	-------

- » Specification does not match set value
 - Check Engine control unit connector **RP** (p. 218) pin **Q3** and Ignition coil connector **AW** (p. 213) pin **1**.
 - Check wire from Engine control unit connector **RP** (p. 218) pin **Q3** to Ignition coil connector **AW** (p. 213) pin **1**.
- » If the specifications have been met:
 - Check the next possible cause
Ignition coil – the control wire has a short circuit to ground (terminal 31)

Ignition coil – the control wire has a short circuit to ground (terminal 31)

Condition

- + Diagnostic tool is disconnected
- + Engine control unit is disconnected (p. 23)

3 Engine control trouble code

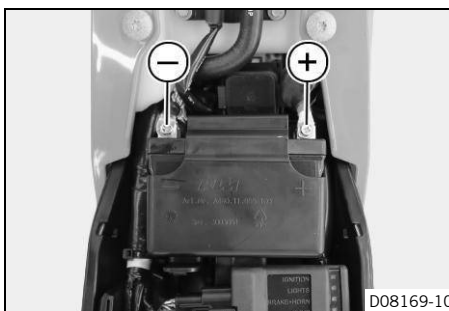
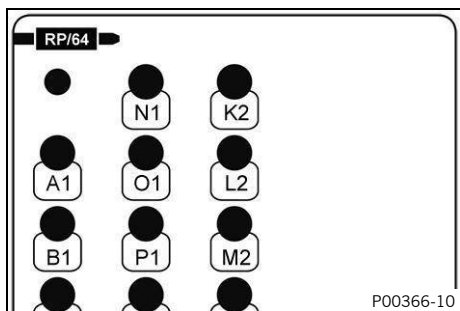

- + The breakout box is connected to the engine control unit main wiring harness with adapter **00029095016**
- + Ignition coil is disconnected  (p. 16)
- Ignition coil – check the control wire for a short circuit to ground (terminal 31).



Resistance measurement points



Bob box connector **RP** Pin **Q3** – Measuring point **Ground (-)**

Resistance	$\infty \Omega$
------------	-----------------

- » Specification does not match set value
 - Check wire from Engine control unit connector **RP**  (p. 218) pin **Q3** to Ignition coil connector **AW**  (p. 213) pin **1** for a short circuit to ground (clamp 31).
- » If the specifications have been met:
 - Check the next possible cause
 - Ignition coil – control wire has a short circuit to plus (terminal 30)

Ignition coil – control wire has a short circuit to plus (terminal 30)

Condition

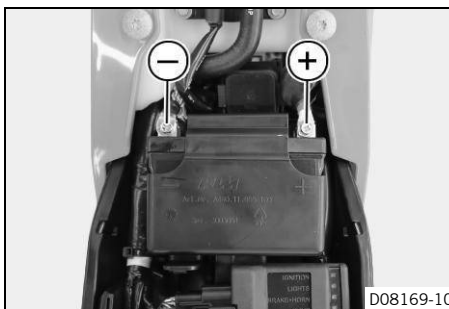
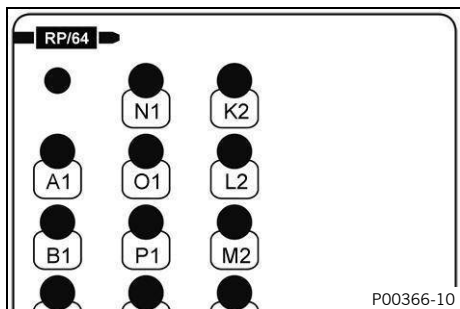

- + Diagnostic tool is disconnected
- + Engine control unit is disconnected  (p. 23)
- + The breakout box is connected to the engine control unit main wiring harness with adapter **00029095016**
- + Ignition coil is disconnected  (p. 16)
- Ignition coil - check the control wire for a short circuit to plus (terminal 30).



Voltage measurement points











Bob box connector **RP** Pin **Q3** – Measuring point **Ground (-)**

Voltage	< 0.1 V
---------	---------

- » Specification does not match set value
 - Check wire from Engine control unit connector **RP**  (p. 218) pin **Q3** to Ignition coil connector **AW**  (p. 213) pin **1** for a short circuit to plus (clamp 30).

Last action

- Contact customer service.









Blink code for malfunction indicator light	 02: Malfunction indicator light flashes 2x short
Display on diagnostic tool	P037000 «Crankshaft speed sensor» «Synchronization faulty»
Error level condition	Crankshaft position sensor - synchronization faulty Time: ≥ 1 s
Function check	Crankshaft speed sensor – checking the signal  (p. 91)
Possible cause	Crankshaft speed sensor – the value is not plausible  (p. 92)
	Crankshaft speed sensor – short circuit to ground  (p. 92)
	Crankshaft speed sensor – signal wires are faulty  (p. 92)
	Crankshaft speed sensor – the signal wires have a short circuit to ground (terminal 31)  (p. 93)
	Crankshaft speed sensor – the signal wires have a short circuit to sensor ground  (p. 94)
	Crankshaft speed sensor – the signal wires have a short circuit to plus (terminal 30)  (p. 94)
	Crankshaft speed sensor – the signal wires have a short circuit to ignition plus (terminal 15)  (p. 95)
	Crankshaft speed sensor – the signal wire has a short circuit to the sensor power supply  (p. 96)
Last action	– Contact customer service.

Crankshaft speed sensor – checking the signal

Condition

- + Diagnostic tool is connected and active
- Select «**Engine control unit**» > «**Measured values**» > «**Engine speed**».
- Execute the start procedure.

«Engine speed»	Starter speed
-----------------------	---------------

- » If the specified value is reached:
 - Clear fault memory with diagnostic tool.
 - Take a test ride.
 - Read out the fault memory using the diagnostics tool.
- » If the specification is not reached:
 - Crankshaft speed sensor – the value is not plausible  (p. 92)
 - Crankshaft speed sensor – short circuit to ground  (p. 92)
 - Crankshaft speed sensor – signal wires are faulty  (p. 92)
 - Crankshaft speed sensor – the signal wires have a short circuit to ground (terminal 31)  (p. 93)
 - Crankshaft speed sensor – the signal wires have a short circuit to sensor ground  (p. 94)
 - Crankshaft speed sensor – the signal wires have a short circuit to plus (terminal 30)  (p. 94)
 - Crankshaft speed sensor – the signal wires have a short circuit to ignition plus (terminal 15)  (p. 95)
 - Crankshaft speed sensor – the signal wire has a short circuit to the sensor power supply  (p. 96)



3 Engine control trouble code

Crankshaft speed sensor – the value is not plausible

Condition

- + Crankshaft position sensor is disconnected  (p. 15)
- Crankshaft speed sensor – check the resistance.

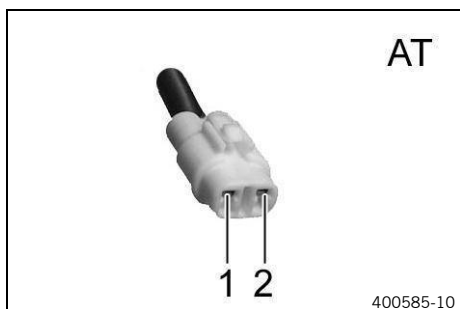

Ω Resistance measurement points
 Crankshaft speed sensor connector **AT** Pin 1
 – Crankshaft speed sensor connector **AT** Pin 2

Crankshaft position sensor	108 Ω ... 132 Ω
----------------------------	-------------------------------

- » Specification does not match set value
 - Change the crankshaft position sensor.
- » If the specifications have been met:
 - Check the next possible cause
 Crankshaft speed sensor – short circuit to ground

Crankshaft speed sensor – short circuit to ground

Condition

- + Diagnostic tool is disconnected
- + Crankshaft position sensor is disconnected  (p. 15)
- Crankshaft speed sensor – check the resistance.

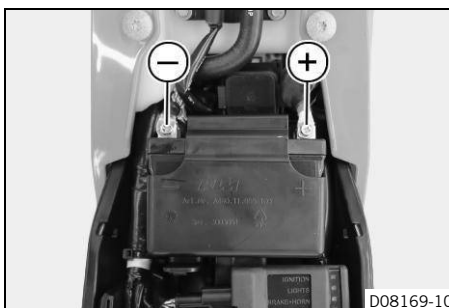
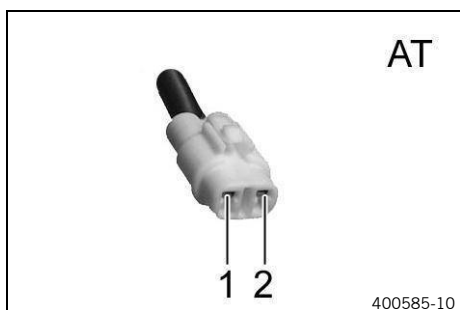

Ω Resistance measurement points
 Crankshaft speed sensor connector **AT** Pin 1 – Measuring point **Ground (-)**

Resistance	$\infty \Omega$
------------	-----------------

- » Specification does not match set value
 - Change the crankshaft position sensor.
- » If the specifications have been met:
 - Check the next possible cause
 Crankshaft speed sensor – signal wires are faulty

Crankshaft speed sensor – signal wires are faulty

Condition





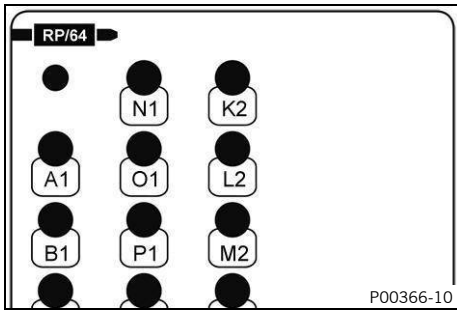

- + Diagnostic tool is disconnected
- + Engine control unit is disconnected  (p. 23)

- + The breakout box is connected to the engine control unit main wiring harness with adapter **00029095016**
- + Crankshaft position sensor is connected  (p. 15)
- Crankshaft speed sensor – check the signal wire.





 Resistance measurement points
Bob box connector **RP** Pin **G4** – Bob box connector **RP** Pin **H4**

Crankshaft position sensor	108 Ω ... 132 Ω
----------------------------	-----------------

- » Specification does not match set value
 - Check Engine control unit connector **RP**  (p. 218) pin **G4** and pin **H4**.
 - Check Crankshaft speed sensor connector **IF**  (p. 216) pin **2** and Crankshaft speed sensor connector **IF**  (p. 216) pin **1**.
 - Check wire from Engine control unit connector **RP**  (p. 218) pin **H4** to Crankshaft speed sensor connector **IF**  (p. 216) pin **2**.
 - Check wire from Engine control unit connector **RP**  (p. 218) pin **G4** to Crankshaft speed sensor connector **IF**  (p. 216) pin **1**.
- » If the specifications have been met:
 - Check the next possible cause
Crankshaft speed sensor – the signal wires have a short circuit to ground (terminal 31)

Crankshaft speed sensor – the signal wires have a short circuit to ground (terminal 31)

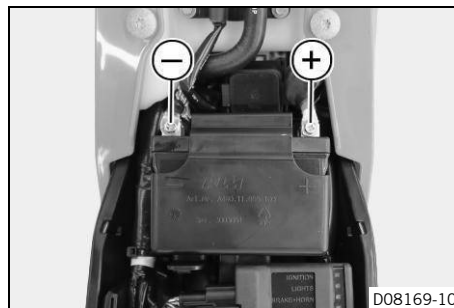
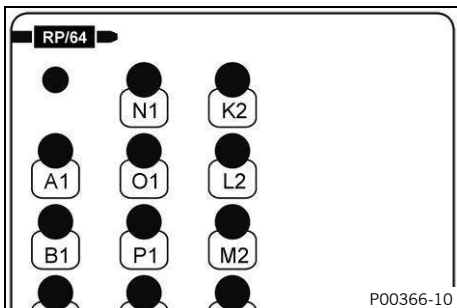

Condition

- + Diagnostic tool is disconnected
- + Engine control unit is disconnected  (p. 23)
- + The breakout box is connected to the engine control unit main wiring harness with adapter **00029095016**
- + Crankshaft position sensor is connected  (p. 15)
- Crankshaft speed sensor – check the signal wires for a short circuit to ground (terminal 31).



 Resistance measurement points
Bob box connector **RP** Pin **G4** – Measuring point **Ground (-)**

Resistance	$\infty \Omega$
------------	-----------------

- » Specification does not match set value
 - Check wire from Engine control unit connector **RP**  (p. 218) pin **G4** to Crankshaft speed sensor connector **IF**  (p. 216) pin **1** for a short circuit to ground (clamp 31).

3 Engine control trouble code

- Check wire from Engine control unit connector **RP** (p. 218) pin **H4** to Crankshaft speed sensor connector **IF** (p. 216) pin **2** for a short circuit to ground (clamp 31).
- » If the specifications have been met:
 - Check the next possible cause
 - Crankshaft speed sensor – the signal wires have a short circuit to sensor ground

Crankshaft speed sensor – the signal wires have a short circuit to sensor ground

Condition

- + Diagnostic tool is disconnected
- + Engine control unit is disconnected (p. 23)
- + The breakout box is connected to the engine control unit main wiring harness with adapter **00029095016**
- + Crankshaft position sensor is connected (p. 15)
- Crankshaft speed sensor – check the signal wires for a short circuit to sensor ground.

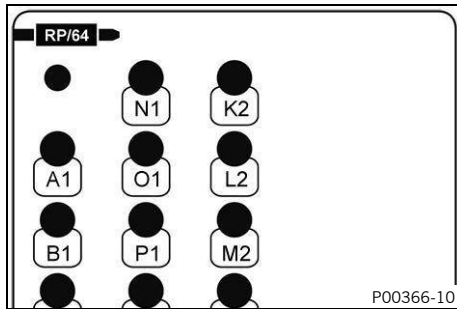

Resistance measurement points

Bob box connector **RP** Pin **G4** – Bob box connector **RP** Pin **H4**

Resistance

$\infty \Omega$

- » Specification does not match set value
 - Check wire from Engine control unit connector **RP** (p. 218) pin **G4** to Crankshaft speed sensor connector **IF** (p. 216) pin **1** for a short circuit to sensor ground.
 - Check wire from Engine control unit connector **RP** (p. 218) pin **H4** to Crankshaft speed sensor connector **IF** (p. 216) pin **2** for a short circuit to sensor ground.
- » If the specifications have been met:
 - Check the next possible cause
 - Crankshaft speed sensor – the signal wires have a short circuit to plus (terminal 30)

Crankshaft speed sensor – the signal wires have a short circuit to plus (terminal 30)

Condition

- + Diagnostic tool is disconnected
- + Engine control unit is disconnected (p. 23)
- + The breakout box is connected to the engine control unit main wiring harness with adapter **00029095016**
- + Crankshaft position sensor is connected (p. 15)
- Crankshaft speed sensor – check the signal wires for a short circuit to plus (terminal 30).

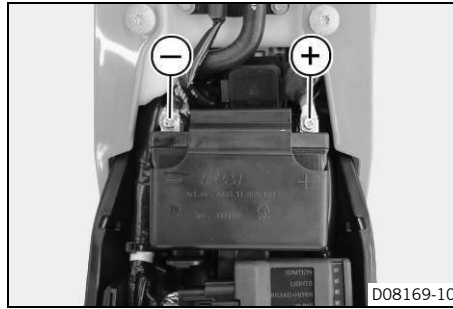
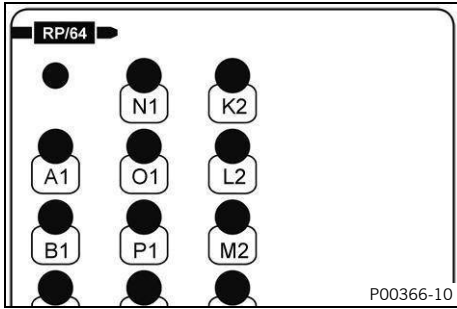

V Voltage measurement points
 Bob box connector **RP** Pin **G4** – Measuring point **Ground (-)**

Voltage	< 0.1 V
---------	---------

- » Specification does not match set value
 - Check wire from Engine control unit connector **RP** (p. 218) pin **G4** to Crankshaft speed sensor connector **IF** (p. 216) pin **1** for a short circuit to plus (clamp 30).
 - Check wire from Engine control unit connector **RP** (p. 218) pin **H4** to Crankshaft speed sensor connector **IF** (p. 216) pin **2** for a short circuit to plus (clamp 30).
- » If the specifications have been met:
 - Check the next possible cause
 Crankshaft speed sensor – the signal wires have a short circuit to ignition plus (terminal 15)

Crankshaft speed sensor – the signal wires have a short circuit to ignition plus (terminal 15)

Condition

- + Diagnostic tool is disconnected
- + Engine control unit is disconnected (p. 23)
- + The breakout box is connected to the engine control unit main wiring harness with adapter **00029095016**
- + Crankshaft position sensor is connected (p. 15)
- Crankshaft speed sensor – check the signal wire for a short circuit to ignition plus (terminal 15).

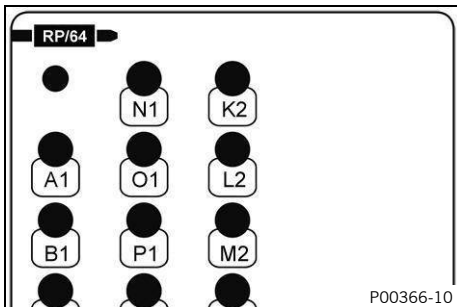

Ω Resistance measurement points
 Bob box connector **RP** Pin **G4** – Bob box connector **RP** Pin **D4**



Resistance	∞ Ω
------------	-----

- » Specification does not match set value
 - Check wire from Engine control unit connector **RP** (p. 218) pin **G4** to Crankshaft speed sensor connector **IF** (p. 216) pin **1** for a short circuit to ignition plus (clamp 15).
 - Check wire from Engine control unit connector **RP** (p. 218) pin **H4** to Crankshaft speed sensor connector **IF** (p. 216) pin **2** for a short circuit to ignition plus (clamp 15).
- » If the specifications have been met:
 - Check the next possible cause
 Crankshaft speed sensor – the signal wire has a short circuit to the sensor power supply

3 Engine control trouble code

Crankshaft speed sensor – the signal wire has a short circuit to the sensor power supply

Condition

- + Diagnostic tool is disconnected
- + Engine control unit is disconnected  (p. 23)
- + The breakout box is connected to the engine control unit main wiring harness with adapter **00029095016**
- + Crankshaft position sensor is connected  (p. 15)
- Crankshaft speed sensor – check the signal wire for a short circuit to the sensor power supply.

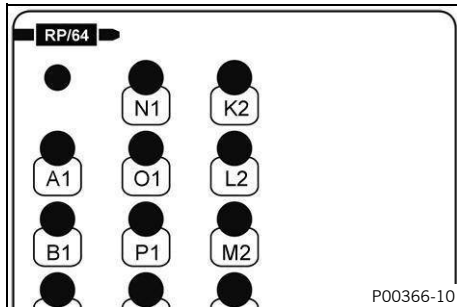





Resistance measurement points

Bob box connector **RP** Pin **G4** – Bob box connector **RP** Pin **D3**



Resistance

$\infty \Omega$

- » Specification does not match set value
 - Check wire from Engine control unit connector **RP**  (p. 218) pin **G4** to Crankshaft speed sensor connector **IF**  (p. 216) pin **1** for a short circuit to the sensor voltage supply.
 - Check wire from Engine control unit connector **RP**  (p. 218) pin **H4** to Crankshaft speed sensor connector **IF**  (p. 216) pin **2** for a short circuit to the sensor voltage supply.

Last action

- Contact customer service.

Blink code for malfunction indicator light	 02: Malfunction indicator light flashes 2x short
Display on diagnostic tool	P037100 «Crankshaft speed sensor» «Signal not plausible»
Error level condition	Crankshaft position sensor - too many impulses Time: ≥ 0.1 s Crankshaft speed sensor – signal implausible
Function check	Crankshaft speed sensor – checking the signal  (p. 97)
Last action	– Contact customer service.

Crankshaft speed sensor – checking the signal

Condition

- + Diagnostic tool is connected and active
- Select «**Engine control unit**» > «**Measured values**» > «**Engine speed**».
- Execute the start procedure.

«Engine speed»	Starter speed
-----------------------	---------------





- » If the specified value is reached:
 - Clear fault memory with diagnostic tool.
 - Take a test ride.
 - Read out the fault memory using the diagnostics tool.
- » If the specification is not reached:
 - Check wires for damage.
 - If necessary, change wires.



Last action

- Contact customer service.

3 Engine control trouble code



Blink code for malfunction indicator light	 52: Malfunction indicator light flashes 5x long, 2x short
Display on diagnostic tool	P044413 «Purge valve» «Circuit fault»
Error level condition	Fuel vapor valve – circuit fault
Function check	Fuel vapor valve – checking the actuation  (p. 98)
Possible cause	Fuel vapor valve – the value is not plausible  (p. 98)
	Fuel vapor valve – the power supply is faulty  (p. 99)
	Fuel vapor valve – the control wire is faulty  (p. 99)
Last action	– Contact customer service.

Fuel vapor valve – checking the actuation

Condition

- + Diagnostic tool is connected and active
- Perform «**Engine control unit**» > «**Actuator test**» > «**Filter bleeding**».

Purge valve	Operating noise
-------------	-----------------

- » If the specified value is reached:
 - Clear fault memory with diagnostic tool.
 - Take a test ride.
 - Read out the fault memory using the diagnostics tool.
- » If the specification is not reached:
 - Fuel vapor valve – the value is not plausible  (p. 98)
 - Fuel vapor valve – the power supply is faulty  (p. 99)
 - Fuel vapor valve – the control wire is faulty  (p. 99)

Fuel vapor valve – the value is not plausible

Condition

- + Purge valve is disconnected  (p. 19)
- Fuel vapor valve – check the resistance.

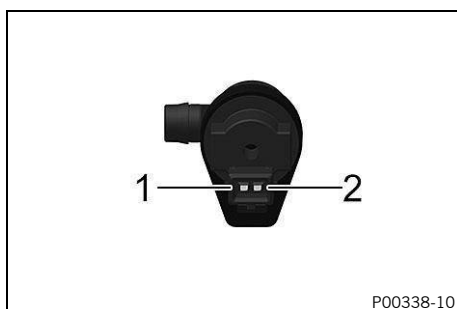

 Resistance measurement points
Purge valve Pin 1 – Purge valve Pin 2



Purge valve	24.2 Ω ... 27.8 Ω
-------------	-------------------

- » Specification does not match set value
 - Change the fuel vapor valve.

- » If the specifications have been met:
 - Check the next possible cause
 - Fuel vapor valve – the power supply is faulty

Fuel vapor valve – the power supply is faulty

Condition

- + Diagnostic tool is connected and active
- + Engine control unit is connected  (p. 23)
- + Purge valve is disconnected  (p. 19)
- Fuel vapor valve – check the power supply.

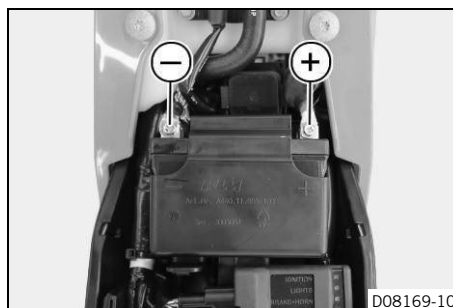
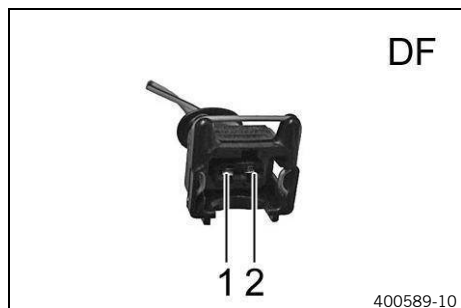



V Voltage measurement points
 Fuel vapor valve connector **DF** Pin **2** – Measuring point **Ground (-)**

The value must not deviate from the battery voltage «VBAT» by more than 1 V.



i **Note**

For the measurement, the measuring points must be subjected to a 12 V/21 W bulb.

- » Specification does not match set value
 - Check Fuel vapor valve connector **DF**  (p. 213) pin **2**.
 - Check wire from Fuel vapor valve connector **DF**  (p. 213) pin **2** to the next node in the wiring harness.
- » If the specifications have been met:
 - Check the next possible cause
 - Fuel vapor valve – the control wire is faulty

Fuel vapor valve – the control wire is faulty

Condition

- + Diagnostic tool is disconnected
- + Engine control unit is disconnected  (p. 23)
- + The breakout box is connected to the engine control unit main wiring harness with adapter **00029095016**
- + Purge valve is disconnected  (p. 19)
- Fuel vapor valve – check the control wire.

3 Engine control trouble code

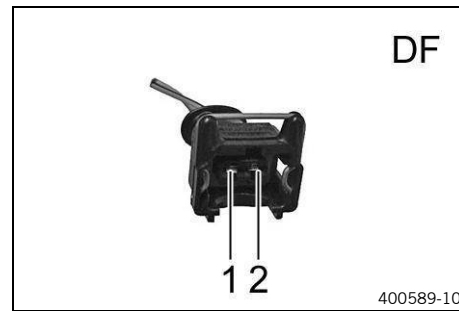
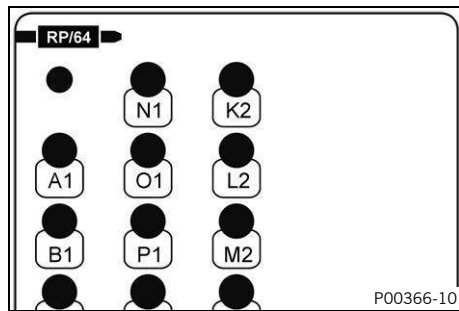

Resistance measurement points







Bob box connector **RP** Pin **04** – Fuel vapor valve connector **DF** Pin **1**

Resistance	$\leq 0.6 \Omega$
------------	-------------------

- » Specification does not match set value
 - Check wire from Engine control unit connector **RP** (p. 218) pin **04** to Fuel vapor valve connector **DF** (p. 213) pin **1**.

Last action

- Contact customer service.





Blink code for malfunction indicator light	 52: Malfunction indicator light flashes 5x long, 2x short
Display on diagnostic tool	P045811 «Purge valve» «Voltage too low»
Error level condition	Fuel vapor valve – voltage too low
Function check	Fuel vapor valve – checking the actuation  (p. 101)
Possible cause	Fuel vapor valve – the value is not plausible  (p. 101)
	Fuel vapor valve – the power supply is faulty  (p. 102)
	Fuel vapor valve – the control wire has a short circuit to ground (terminal 31)  (p. 102)
	Fuel vapor valve valve – the control wire has a short circuit to sensor ground  (p. 103)
Last action	– Contact customer service.

Fuel vapor valve – checking the actuation

Condition

- + Diagnostic tool is connected and active
- Perform «Engine control unit» > «Actuator test» > «Filter bleeding».

Purge valve	Operating noise
-------------	-----------------

- » If the specified value is reached:
 - Clear fault memory with diagnostic tool.
 - Take a test ride.
 - Read out the fault memory using the diagnostics tool.
- » If the specification is not reached:
 - Fuel vapor valve – the value is not plausible  (p. 101)
 - Fuel vapor valve – the power supply is faulty  (p. 102)
 - Fuel vapor valve – the control wire has a short circuit to ground (terminal 31)  (p. 102)
 - Fuel vapor valve valve – the control wire has a short circuit to sensor ground  (p. 103)



Fuel vapor valve – the value is not plausible

Condition

- + Purge valve is disconnected  (p. 19)
- Fuel vapor valve – check the resistance.

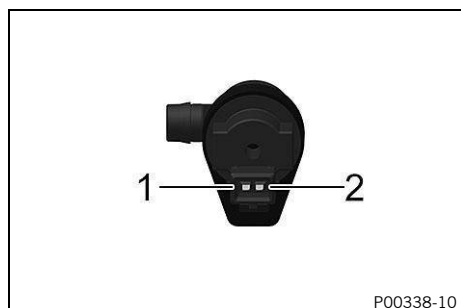

 Resistance measurement points
 Purge valve Pin 1 – Purge valve Pin 2



3 Engine control trouble code

Purge valve	24.2 Ω ... 27.8 Ω
-------------	---------------------------------

- » Specification does not match set value
 - Change the fuel vapor valve.
- » If the specifications have been met:
 - Check the next possible cause
 - Fuel vapor valve – the power supply is faulty

Fuel vapor valve – the power supply is faulty

Condition

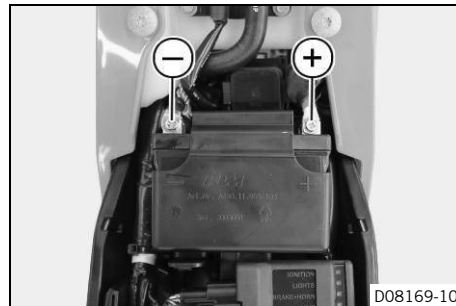
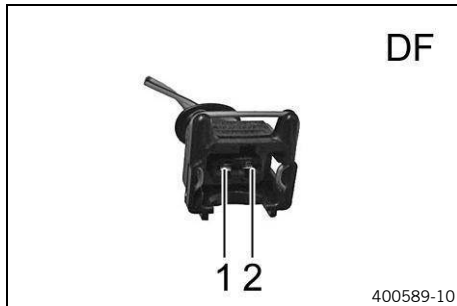

- + Diagnostic tool is connected and active
- + Engine control unit is connected  (p. 23)
- + Purge valve is disconnected  (p. 19)
- Fuel vapor valve – check the power supply.



- V** Voltage measurement points
Fuel vapor valve connector **DF** Pin **2** – Measuring point **Ground (-)**



The value must not deviate from the battery voltage «**VBAT**» by more than 1 V.

- i** **Note**
For the measurement, the measuring points must be subjected to a 12 V/21 W bulb.

- » Specification does not match set value
 - Check Fuel vapor valve connector **DF**  (p. 213) pin **2**.
 - Check wire from Fuel vapor valve connector **DF**  (p. 213) pin **2** to the next node in the wiring harness.
- » If the specifications have been met:
 - Check the next possible cause
 - Fuel vapor valve – the control wire has a short circuit to ground (terminal 31)

Fuel vapor valve – the control wire has a short circuit to ground (terminal 31)

Condition

- + Diagnostic tool is disconnected
- + Engine control unit is disconnected  (p. 23)
- + The breakout box is connected to the engine control unit main wiring harness with adapter **00029095016**
- + Purge valve is disconnected  (p. 19)
- Fuel vapor valve – check the control wire for a short circuit to ground (terminal 31).

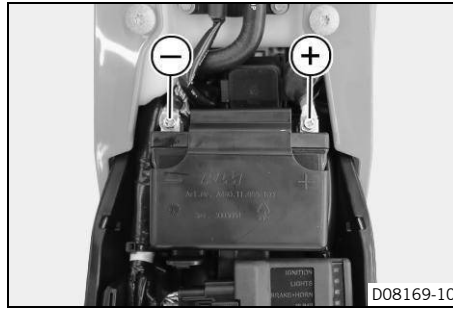
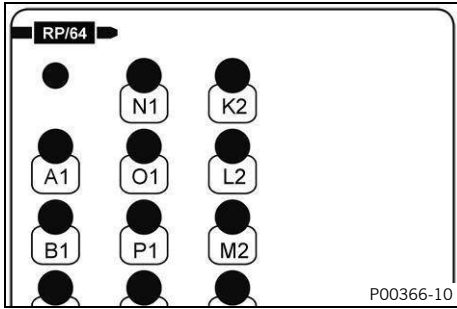

Ω Resistance measurement points
 Bob box connector **RP** Pin **04** – Measuring point **Ground (-)**

Resistance	$\infty \Omega$
------------	-----------------

- » Specification does not match set value
 - Check wire from Engine control unit connector **RP** (p. 218) pin **04** to Fuel vapor valve connector **DF** (p. 213) pin **1** for a short circuit to ground (clamp 31).
- » If the specifications have been met:
 - Check the next possible cause
 Fuel vapor valve valve – the control wire has a short circuit to sensor ground

Fuel vapor valve valve – the control wire has a short circuit to sensor ground

Condition

- + Diagnostic tool is disconnected
- + Engine control unit is disconnected (p. 23)
- + The breakout box is connected to the engine control unit main wiring harness with adapter **00029095016**
- + Purge valve is disconnected (p. 19)
- Fuel vapor valve – check the control wire for a short circuit to sensor ground.

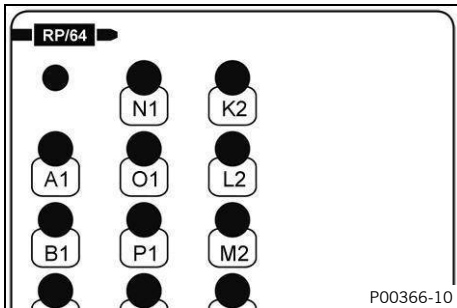

Ω Resistance measurement points
 Bob box connector **RP** Pin **04** – Bob box connector **RP** Pin **E2**







Resistance	$\infty \Omega$
------------	-----------------

- » Specification does not match set value
 - Check wire from Engine control unit connector **RP** (p. 218) pin **04** to Fuel vapor valve connector **DF** (p. 213) pin **1** for a short circuit to sensor ground.

Last action

- Contact customer service.

3 Engine control trouble code





Blink code for malfunction indicator light	 52: Malfunction indicator light flashes 5x long, 2x short
Display on diagnostic tool	P045912 «Purge valve» «Voltage too high»
Error level condition	Fuel vapor valve – voltage too high
Function check	Fuel vapor valve – checking the actuation  (p. 104)
Possible cause	Fuel vapor valve – the value is not plausible  (p. 104)
	Fuel vapor valve – the control wire has a short circuit to plus (terminal 30)  (p. 105)
	Fuel vapor valve - the control wire has a short circuit to ignition plus (terminal 15)  (p. 105)
	Fuel vapor valve – control wire has a short circuit to the sensor power supply  (p. 106)
Last action	– Contact customer service.

Fuel vapor valve – checking the actuation

Condition

- + Diagnostic tool is connected and active
- Perform «**Engine control unit**» > «**Actuator test**» > «**Filter bleeding**».

Purge valve	Operating noise
-------------	-----------------

- » If the specified value is reached:
 - Clear fault memory with diagnostic tool.
 - Take a test ride.
 - Read out the fault memory using the diagnostics tool.
- » If the specification is not reached:
 - Fuel vapor valve – the value is not plausible  (p. 104)
 - Fuel vapor valve – the control wire has a short circuit to plus (terminal 30)  (p. 105)
 - Fuel vapor valve - the control wire has a short circuit to ignition plus (terminal 15)  (p. 105)
 - Fuel vapor valve – control wire has a short circuit to the sensor power supply  (p. 106)

Fuel vapor valve – the value is not plausible

Condition

- + Purge valve is disconnected  (p. 19)
- Fuel vapor valve – check the resistance.

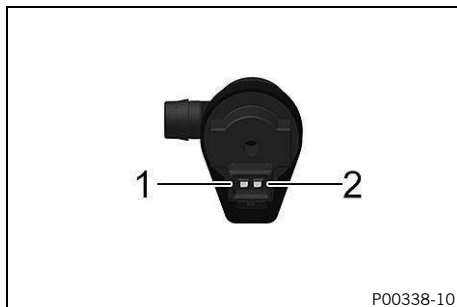

Resistance measurement points
Purge valve Pin 1 – Purge valve Pin 2

Purge valve	24.2 Ω ... 27.8 Ω
-------------	-------------------

- » Specification does not match set value
 - Change the fuel vapor valve.
- » If the specifications have been met:
 - Check the next possible cause
 - Fuel vapor valve – the control wire has a short circuit to plus (terminal 30)

Fuel vapor valve – the control wire has a short circuit to plus (terminal 30)

Condition

- + Diagnostic tool is disconnected
- + Engine control unit is disconnected (p. 23)
- + The breakout box is connected to the engine control unit main wiring harness with adapter **00029095016**
- + Purge valve is disconnected (p. 19)
- Fuel vapor valve – check the control wire for a short circuit to plus (terminal 30).

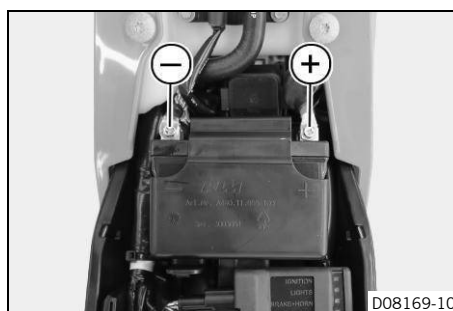
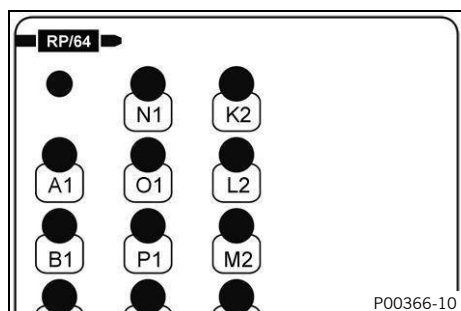

V Voltage measurement points
 Bob box connector **RP** Pin **04** – Measuring point **Ground (-)**

Voltage	≤ 0.1 V
---------	---------

- » Specification does not match set value
 - Check wire from Engine control unit connector **RP** (p. 218) pin **04** to Fuel vapor valve connector **DF** (p. 213) pin **1** for a short circuit to plus (clamp 30).
- » If the specifications have been met:
 - Check the next possible cause
 - Fuel vapor valve - the control wire has a short circuit to ignition plus (terminal 15)

Fuel vapor valve - the control wire has a short circuit to ignition plus (terminal 15)

Condition

- + Diagnostic tool is disconnected
- + Engine control unit is disconnected (p. 23)
- + The breakout box is connected to the engine control unit main wiring harness with adapter **00029095016**
- + Purge valve is disconnected (p. 19)
- Fuel vapor valve – check the control wire for a short circuit to ignition plus (terminal 15).

3 Engine control trouble code

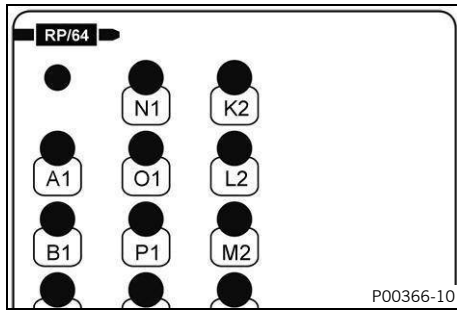

Ω Resistance measurement points
Bob box connector **RP** Pin **04** – Bob box connector **RP** Pin **D4**

Resistance	$\infty \Omega$
------------	-----------------

- » Specification does not match set value
 - Check wire from Engine control unit connector **RP** (p. 218) pin **04** to Fuel vapor valve connector **DF** (p. 213) pin **1** for a short circuit to ignition plus (clamp 15).
- » If the specifications have been met:
 - Check the next possible cause
Fuel vapor valve – control wire has a short circuit to the sensor power supply

Fuel vapor valve – control wire has a short circuit to the sensor power supply

Condition

- + Diagnostic tool is disconnected
- + Engine control unit is disconnected (p. 23)
- + The breakout box is connected to the engine control unit main wiring harness with adapter **00029095016**
- + Purge valve is disconnected (p. 19)
- Fuel vapor valve – check the control wire for a short circuit to the sensor power supply.

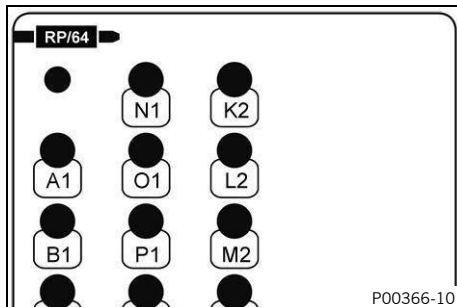



Ω Resistance measurement points
Bob box connector **RP** Pin **04** – Bob box connector **RP** Pin **D3**

Resistance	$\infty \Omega$
------------	-----------------

- » Specification does not match set value
 - Check wire from Engine control unit connector **RP** (p. 218) pin **04** to Fuel vapor valve connector **DF** (p. 213) pin **1** for a short circuit to the sensor voltage supply.



Last action

- Contact customer service.

Blink code for malfunction indicator light	 50: Malfunction indicator light flashes 5x long
Display on diagnostic tool	P047531 «Exhaust control actuator» «No signal»
Error level condition	Exhaust control actuator – no signal
Possible cause	Exhaust control actuator – the signal wire is faulty  (p. 107)
	Exhaust control actuator – the power supply is faulty  (p. 107)
Last action	– Contact customer service.

Exhaust control actuator – the signal wire is faulty

Condition



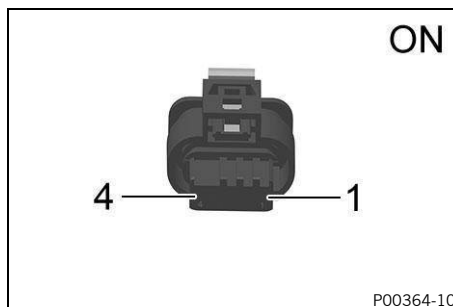
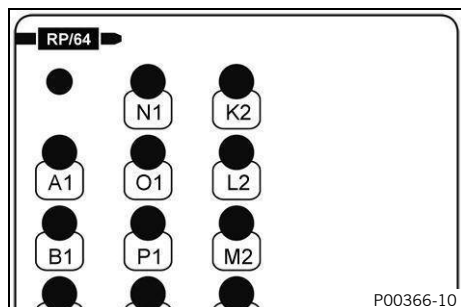

- + Diagnostic tool is disconnected
- + Engine control unit is disconnected  (p. 23)
- + The breakout box is connected to the engine control unit main wiring harness with adapter **00029095016**
- + Exhaust control actuator is disconnected  (p. 24)
- Exhaust control actuator – check the signal wire.



Resistance measurement points



Bob box connector **RP** Pin **B1** – Exhaust control actuator socket connector **ON** Pin **4**

Resistance	$\leq 0.6 \Omega$
------------	-------------------

- » Specification does not match set value
 - Check Engine control unit connector **RP**  (p. 218) pin **B1** and Exhaust control actuator socket connector **ON**  (p. 218) pin **4**.
 - Check wire from Engine control unit connector **RP**  (p. 218) pin **B1** to Exhaust control actuator socket connector **ON**  (p. 218) pin **4**.
- » If the specifications have been met:
 - Check the next possible cause
Exhaust control actuator – the power supply is faulty

Exhaust control actuator – the power supply is faulty

Condition

- + Diagnostic tool is connected and active
- + Engine control unit is connected  (p. 23)
- + Exhaust control actuator is disconnected  (p. 24)
- Exhaust control actuator – check the power supply.

3 Engine control trouble code

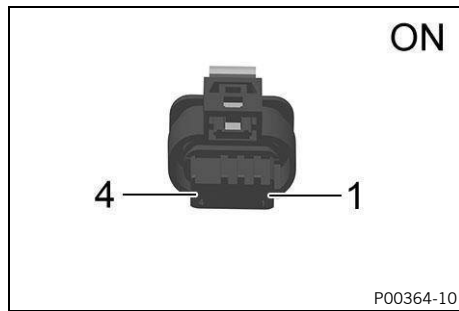

- V** Voltage measurement points
Exhaust control actuator socket connector **ON** Pin 1
– Exhaust control actuator socket connector **ON** Pin 3



The value must not deviate from the battery voltage «VBAT» by more than 1 V.

i **Note**
For the measurement, the measuring points must be subjected to a 12 V/21 W bulb.

- » Specification does not match set value
 - Check Exhaust control actuator socket connector **ON** (p. 218) pin 1 and pin 3.
 - Check wire from Exhaust control actuator socket connector **ON** (p. 218) pin 1 to the next node in the wiring harness.
 - Check wire from Exhaust control actuator socket connector **ON** (p. 218) pin 3 to the next node in the wiring harness.

Last action

- Contact customer service.

Blink code for malfunction indicator light	 50: Malfunction indicator light flashes 5x long
Display on diagnostic tool	P04754B «Exhaust control actuator» «Temperature too high»
Error level condition	Exhaust control actuator – temperature too high
Function check	Checking the exhaust control actuator  (p. 109)
Possible cause	Exhaust control actuator has no function  (p. 109)
Last action	– Contact customer service.

Checking the exhaust control actuator

Condition

+ Diagnostic tool is connected and active

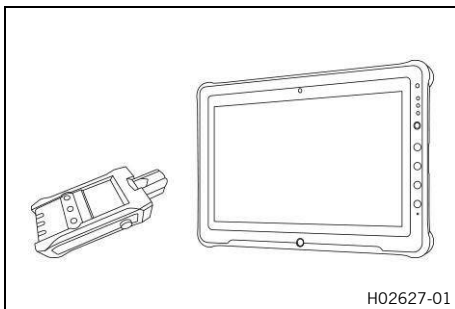

- Execute «**Engine control unit**» > «**Actuator test**» > «**Exhaust control actuator**».

The exhaust control actuator audibly moves from the lower to upper stop position.

- » If the specified value is reached:
 - Clear fault memory with diagnostic tool.
 - Take a test ride.
 - Read out the fault memory using the diagnostics tool.
- » If the specification is not reached:
Exhaust control actuator has no function  (p. 109)





Exhaust control actuator has no function

- Check the exhaust control actuator for mechanical damage.
 - » Specification does not match set value
 - Change exhaust control actuator.

Last action

- Contact customer service.

3 Engine control trouble code

Blink code for malfunction indicator light	 50: Malfunction indicator light flashes 5x long
Display on diagnostic tool	P047578 «Exhaust control actuator» «Incorrect setting»
Error level condition	Exhaust control actuator – incorrect setting
Function check	Calibrating the exhaust control actuator  (p. 110)
Last action	– Change exhaust control actuator.

Calibrating the exhaust control actuator

Condition

+ Diagnostic tool is connected and active

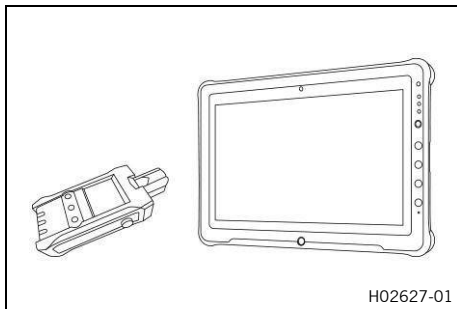

- Execute «**Engine control unit**» > «**Control unit functions**» > «**Teach in exhaust control actuator**».





Note

The instructions must be followed precisely.

- » If the specified value is reached:
 - Clear fault memory with diagnostic tool.
 - Take a test ride.
 - Read out the fault memory using the diagnostics tool.



Last action

- Change exhaust control actuator.

Blink code for malfunction indicator light	 50: Malfunction indicator light flashes 5x long
Display on diagnostic tool	P047900 «Exhaust control actuator» «Setpoint value signal faulty»
Error level condition	Exhaust control actuator – setpoint value signal faulty
Possible cause	Exhaust control actuator – control wire is faulty  (p. 111)
	Exhaust control actuator – the power supply is faulty  (p. 111)
Last action	– Contact customer service.

Exhaust control actuator – control wire is faulty

Condition



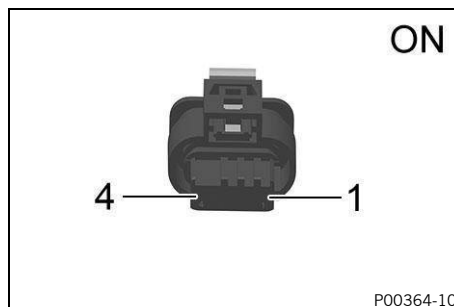
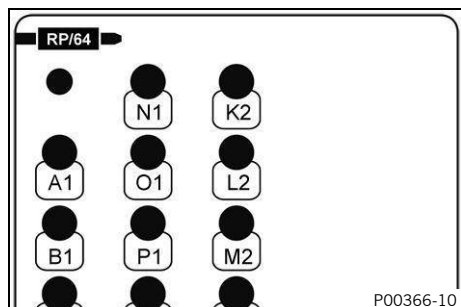

- + Diagnostic tool is disconnected
- + Engine control unit is disconnected  (p. 23)
- + The breakout box is connected to the engine control unit main wiring harness with adapter **00029095016**
- + Exhaust control actuator is disconnected  (p. 24)
- Exhaust control actuator – check the control wire.



Resistance measurement points



Bob box connector **RP** Pin **P2** – Exhaust control actuator socket connector **ON** Pin **2**

Resistance	$\leq 0.6 \Omega$
------------	-------------------

- » Specification does not match set value
 - Check Engine control unit connector **RP**  (p. 218) pin **P2** and Exhaust control actuator socket connector **ON**  (p. 218) pin **2**.
 - Check wire from Engine control unit connector **RP**  (p. 218) pin **P2** to Exhaust control actuator socket connector **ON**  (p. 218) pin **2**.
- » If the specifications have been met:
 - Check the next possible cause
Exhaust control actuator – the power supply is faulty

Exhaust control actuator – the power supply is faulty

Condition

- + Diagnostic tool is connected and active
- + Engine control unit is connected  (p. 23)
- + Exhaust control actuator is disconnected  (p. 24)
- Exhaust control actuator – check the power supply.

3 Engine control trouble code

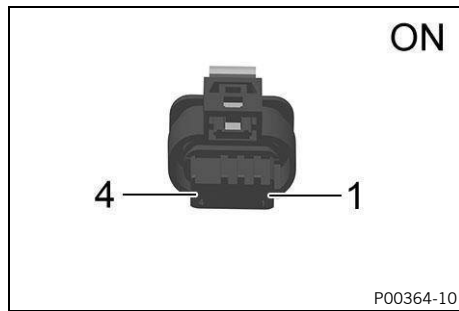

- V** Voltage measurement points
Exhaust control actuator socket connector **ON** Pin 1
– Exhaust control actuator socket connector **ON** Pin 3







The value must not deviate from the battery voltage «VBAT» by more than 1 V.

i **Note**
For the measurement, the measuring points must be subjected to a 12 V/21 W bulb.

- » Specification does not match set value
 - Check Exhaust control actuator socket connector **ON** (p. 218) pin 1 and pin 3.
 - Check wire from Exhaust control actuator socket connector **ON** (p. 218) pin 1 to the next node in the wiring harness.
 - Check wire from Exhaust control actuator socket connector **ON** (p. 218) pin 3 to the next node in the wiring harness.

Last action

- Contact customer service.

Blink code for malfunction indicator light	 42: Malfunction indicator light flashes 4x long, 2x short
Display on diagnostic tool	P052211 «Oil pump» «Input signal too low»
Error level condition	Oil pump - input signal too low Time: ≥ 1 s
Possible cause	Oil pump - the value is not plausible  (p. 113)
	Oil pump – the power supply is faulty  (p. 113)
	Oil pump - the control wire is faulty  (p. 114)
	Oil pump - the control wire has a short circuit to ground (terminal 31)  (p. 115)
	Oil pump – the control wire has a short circuit to sensor ground  (p. 115)
Last action	– Contact customer service.

Oil pump - the value is not plausible

Condition

- + Oil pump is disconnected  (p. 17)
- Oil pump - check the resistance.

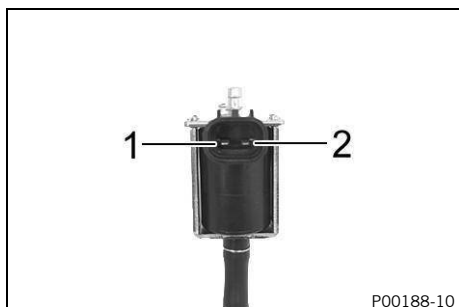



 Resistance measurement points
Oil pump Pin 1 – Oil pump Pin 2

Oil pump	
Resistance at: 20 °C (68.0 °F)	11.2 Ω ... 13.6 Ω

- » Specification does not match set value
 - Change the oil pump.
- » If the specifications have been met:
 - Check the next possible cause
Oil pump – the power supply is faulty

Oil pump – the power supply is faulty

Condition

- + Diagnostic tool is connected and active
- + Engine control unit is connected  (p. 23)
- + Oil pump is disconnected  (p. 17)
- Oil pump - check the power supply.

3 Engine control trouble code

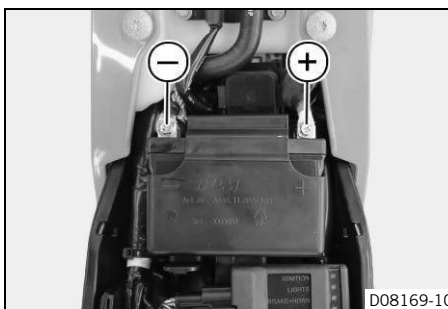
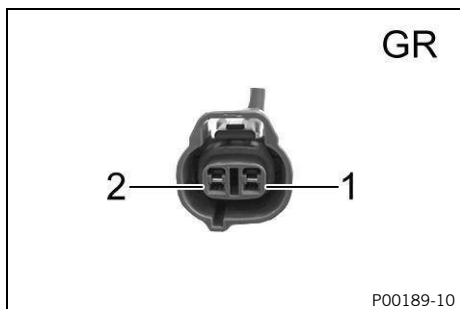

V Voltage measurement points
Oil pump connector **GR** Pin **1** – Measuring point **Ground (-)**

The value must not deviate from the battery voltage «**VBAT**» by more than 1 V.

i **Note**
For the measurement, the measuring points must be subjected to a 12 V/21 W bulb.

- » Specification does not match set value
 - Check Oil pump connector **GR** (p. 215) pin **1**.
 - Check wire from Oil pump connector **GR** (p. 215) pin **1** to the next node in the wiring harness.
- » If the specifications have been met:
 - Check the next possible cause
Oil pump - the control wire is faulty

Oil pump - the control wire is faulty

Condition

- + Diagnostic tool is disconnected
- + Engine control unit is disconnected (p. 23)
- + The breakout box is connected to the engine control unit main wiring harness with adapter **00029095016**
- + Oil pump is disconnected (p. 17)
- Oil pump - check the control wire.

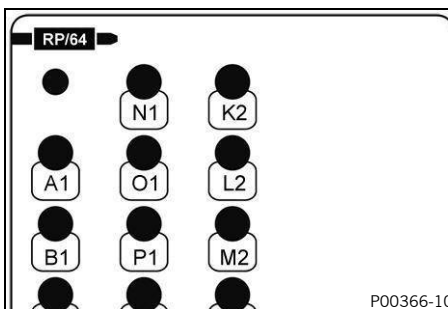
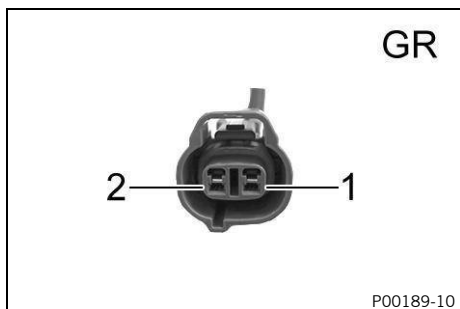

Ω Resistance measurement points
Bob box connector **RP** Pin **03** – Oil pump connector **GR** Pin **2**



Resistance	≤ 0.6 Ω
------------	---------

- » Specification does not match set value
 - Check Engine control unit connector **RP** (p. 218) pin **03** and Oil pump connector **GR** (p. 215) pin **2**.
 - Check wire from Engine control unit connector **RP** (p. 218) pin **03** to Oil pump connector **GR** (p. 215) pin **2**.

- » If the specifications have been met:
 - Check the next possible cause
 - Oil pump - the control wire has a short circuit to ground (terminal 31)

Oil pump - the control wire has a short circuit to ground (terminal 31)

Condition

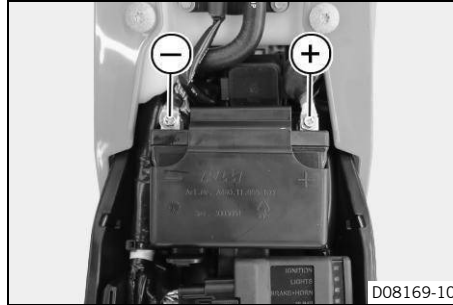
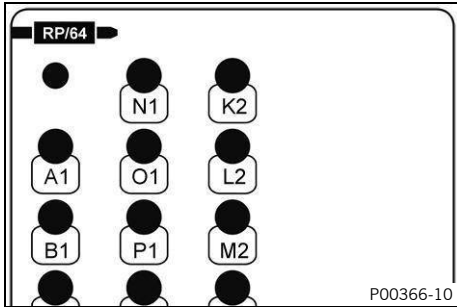

- + Diagnostic tool is disconnected
- + Engine control unit is disconnected  (p. 23)
- + The breakout box is connected to the engine control unit main wiring harness with adapter **00029095016**
- + Oil pump is disconnected  (p. 17)
- Oil pump - check the control wire for a short circuit to ground (terminal 31).



Resistance measurement points



Bob box connector **RP** Pin **03** – Measuring point **Ground (-)**

Resistance	$\infty \Omega$
------------	-----------------

- » Specification does not match set value
 - Check wire from Engine control unit connector **RP**  (p. 218) pin **03** to Oil pump connector **GR**  (p. 215) pin **2** for a short circuit to ground (clamp 31).
- » If the specifications have been met:
 - Check the next possible cause
 - Oil pump – the control wire has a short circuit to sensor ground

Oil pump – the control wire has a short circuit to sensor ground

Condition

- + Diagnostic tool is disconnected
- + Engine control unit is disconnected  (p. 23)
- + The breakout box is connected to the engine control unit main wiring harness with adapter **00029095016**
- + Oil pump is disconnected  (p. 17)
- Oil pump – check the control wire for a short circuit to sensor ground.

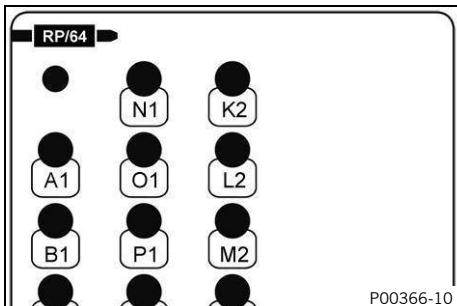



Resistance measurement points

Bob box connector **RP** Pin **03** – Bob box connector **RP** Pin **E2**

Resistance	$\infty \Omega$
------------	-----------------





- » Specification does not match set value

3 Engine control trouble code

- Check wire from Engine control unit connector **RP**  (p. 218) pin **03** to Oil pump connector **GR**  (p. 215) pin **2** for a short circuit to sensor ground.

Last action

- Contact customer service.

Blink code for malfunction indicator light	 42: Malfunction indicator light flashes 4x long, 2x short
Display on diagnostic tool	P052312 «Oil pump» «Input signal too high»
Error level condition	Oil pump - input signal too high
Possible cause	Oil pump - the value is not plausible  (p. 117)
	Oil pump - the control wire has a short circuit to plus (terminal 30)  (p. 117)
	Oil pump – the control wire has a short circuit to ignition plus (terminal 15)  (p. 118)
	Oil pump - control wire has a short circuit to the sensor power supply  (p. 118)
Last action	– Contact customer service.

Oil pump - the value is not plausible

Condition

- + Oil pump is disconnected  (p. 17)
- Oil pump - check the resistance.

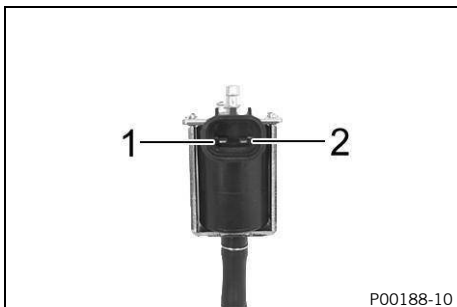



 Resistance measurement points
 Oil pump Pin 1 – Oil pump Pin 2

Oil pump	
Resistance at: 20 °C (68.0 °F)	11.2 Ω ... 13.6 Ω

- » Specification does not match set value
 - Change the oil pump.
- » If the specifications have been met:
 - Check the next possible cause
 - Oil pump - the control wire has a short circuit to plus (terminal 30)

Oil pump - the control wire has a short circuit to plus (terminal 30)

Condition

- + Diagnostic tool is disconnected
- + Engine control unit is disconnected  (p. 23)
- + The breakout box is connected to the engine control unit main wiring harness with adapter **00029095016**
- + Oil pump is disconnected  (p. 17)
- Oil pump - check the control wire for a short circuit to plus (terminal 30).

3 Engine control trouble code

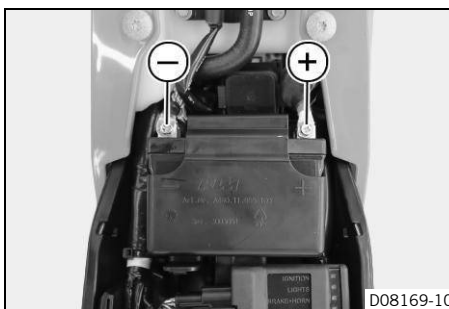
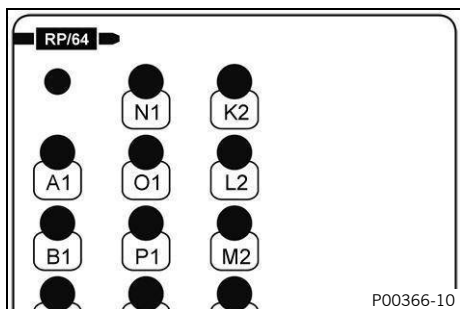

V Voltage measurement points
Bob box connector **RP** Pin **03** – Measuring point **Ground (-)**

Voltage	< 0.1 V
---------	---------

- » Specification does not match set value
 - Check wire from Engine control unit connector **RP** (p. 218) pin **03** to Oil pump connector **GR** (p. 215) pin **2** for a short circuit to plus (clamp 30).
- » If the specifications have been met:
 - Check the next possible cause
Oil pump – the control wire has a short circuit to ignition plus (terminal 15)

Oil pump – the control wire has a short circuit to ignition plus (terminal 15)

Condition

- + Diagnostic tool is disconnected
- + Engine control unit is disconnected (p. 23)
- + The breakout box is connected to the engine control unit main wiring harness with adapter **00029095016**
- + Oil pump is disconnected (p. 17)
- Oil pump - check the control wire for a short circuit to ignition plus (terminal 15).

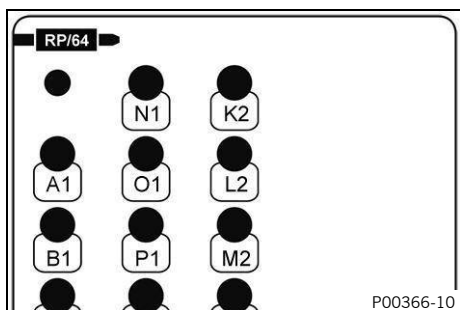

Ω Resistance measurement points
Bob box connector **RP** Pin **03** – Bob box connector **RP** Pin **D4**

Resistance	$\infty \Omega$
------------	-----------------

- » Specification does not match set value
 - Check wire from Engine control unit connector **RP** (p. 218) pin **03** to Oil pump connector **GR** (p. 215) pin **2** for a short circuit to ignition plus (clamp 15).
- » If the specifications have been met:
 - Check the next possible cause
Oil pump - control wire has a short circuit to the sensor power supply

Oil pump - control wire has a short circuit to the sensor power supply

Condition

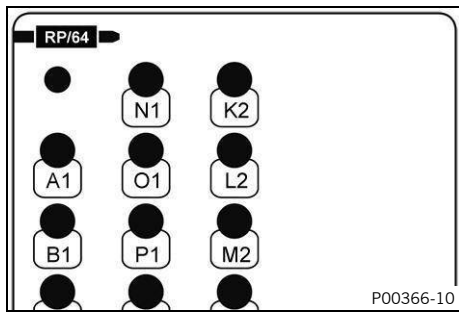

- + Diagnostic tool is disconnected
- + Engine control unit is disconnected (p. 23)
- + The breakout box is connected to the engine control unit main wiring harness with adapter **00029095016**

- + Oil pump is disconnected  (p. 17)
- Oil pump - check the control wire for a short circuit to the sensor power supply.



 Resistance measurement points
 Bob box connector **RP** Pin **03** – Bob box connector **RP** Pin **D3**







Resistance	$\infty \Omega$
------------	-----------------

- » Specification does not match set value
 - Check wire from Engine control unit connector **RP**  (p. 218) pin **03** to Oil pump connector **GR**  (p. 215) pin **2** for a short circuit to the sensor voltage supply.

Last action

- Contact customer service.

3 Engine control trouble code

Blink code for malfunction indicator light	 21: Malfunction indicator light flashes 2x long, 1x short
Display on diagnostic tool	P056200 «Battery voltage» «Input voltage too low»
Error level condition	Battery voltage - input voltage too low Engine control unit power supply: ≤ 9.9 V Time: ≥ 1 s Battery voltage - input voltage too low
Function check	Checking the charging voltage  (p. 120)
Possible cause	Engine control unit – power supply 1 is faulty  (p. 120)
	Engine control unit – voltage supply 2 is faulty  (p. 121)
	Engine control unit – voltage supply 3 is faulty  (p. 122)
	Engine control unit – the ground wire (I) is faulty  (p. 122)
	Engine control unit – the ground wire (II) is faulty  (p. 123)
Last action	– Contact customer service.

Checking the charging voltage



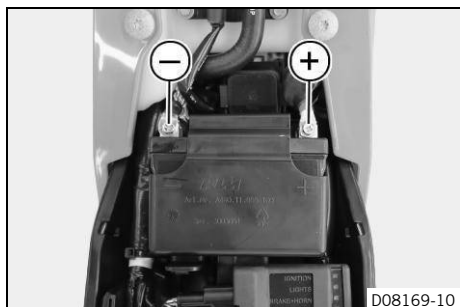

Condition

- + The 12 V battery must be fully functional and completely charged.
- Carry out the starting procedure.
- Take the measurement.



V Voltage measurement points
Measuring point **Plus (+)** – Measuring point **Ground (-)**

Charging voltage	13.5 V ... 15.0 V
------------------	-------------------

- » If the displayed value is less than the specified value:
 - Check alternator.
- » If the specification is not reached:
 - Engine control unit – power supply 1 is faulty  (p. 120)
 - Engine control unit – voltage supply 2 is faulty  (p. 121)
 - Engine control unit – voltage supply 3 is faulty  (p. 122)
 - Engine control unit – the ground wire (I) is faulty  (p. 122)
 - Engine control unit – the ground wire (II) is faulty  (p. 123)

Engine control unit – power supply 1 is faulty

Condition

- + Ignition system is on

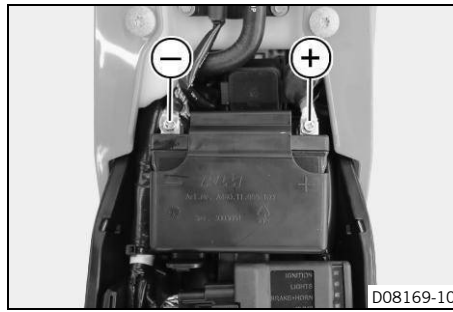
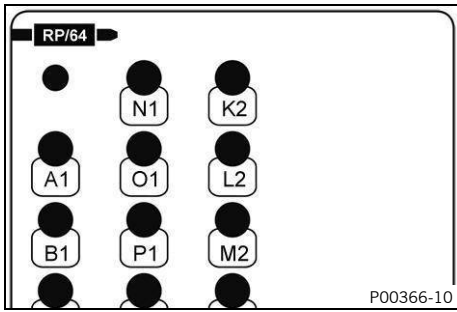

- + Engine control unit is disconnected  (p. 23)
- + The breakout box is connected to the engine control unit main wiring harness with adapter **00029095016**
- Engine control unit – check the power supply 1.



V Voltage measurement points
 Bob box connector **RP** Pin **Q4** – Measuring point **Ground (-)**

The value must not deviate from the battery voltage «VBAT» by more than 1 V.

i **Note**
 For the measurement, the measuring points must be subjected to a 12 V/21 W bulb.

- » Specification does not match set value
 - Check the fuses.
 - Check Engine control unit connector **RP**  (p. 218) pin **Q4**.
 - Check from Engine control unit connector **RP**  (p. 218) pin **Q4** according to the wiring diagram.
- » If the specifications have been met:
 - Check the next possible cause
 Engine control unit – voltage supply 2 is faulty

Engine control unit – voltage supply 2 is faulty

Condition

- + Ignition system is on
- + Engine control unit is disconnected  (p. 23)
- + The breakout box is connected to the engine control unit main wiring harness with adapter **00029095016**
- Engine control unit – check voltage supply 2

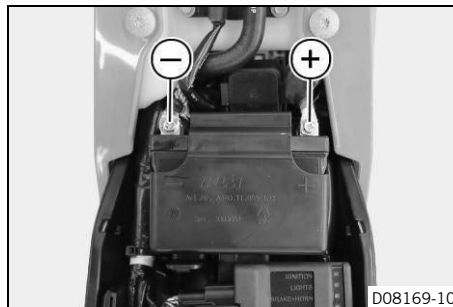
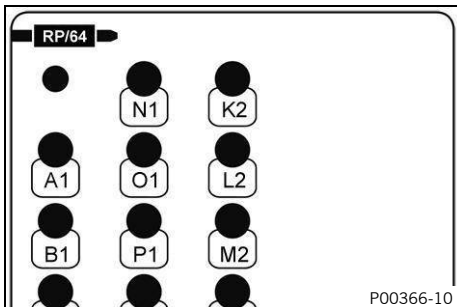

V Voltage measurement points
 Bob box connector **RP** Pin **C4** – Measuring point **Ground (-)**

The value must not deviate from the battery voltage «VBAT» by more than 1 V.

3 Engine control trouble code

Note

For the measurement, the measuring points must be subjected to a 12 V/21 W bulb.

- » Specification does not match set value
 - Check the fuses.
 - Check Engine control unit connector **RP** (p. 218) pin **C4**.
 - Check from Engine control unit connector **RP** (p. 218) pin **C4** according to the wiring diagram.
- » If the specifications have been met:
 - Check the next possible cause
 - Engine control unit – voltage supply 3 is faulty

Engine control unit – voltage supply 3 is faulty

Condition

- + Ignition system is on
- + Engine control unit is disconnected (p. 23)
- + The breakout box is connected to the engine control unit main wiring harness with adapter **00029095016**
- Engine control unit – check voltage supply 3

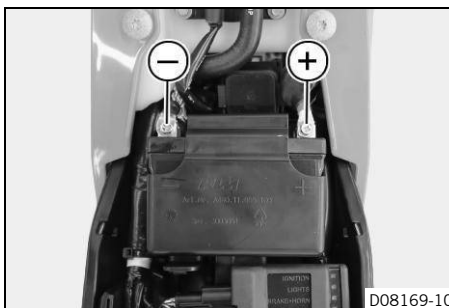
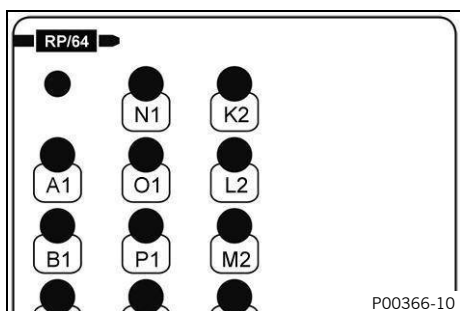

V

Voltage measurement points

Bob box connector **RP** Pin **D4** – Measuring point **Ground (-)**

The value must not deviate from the battery voltage «VBAT» by more than 1 V.

Note

For the measurement, the measuring points must be subjected to a 12 V/21 W bulb.

- » Specification does not match set value
 - Check the fuse.
 - Check Engine control unit connector **RP** (p. 218) pin **D4**.
 - Check from Engine control unit connector **RP** (p. 218) pin **D4** according to the wiring diagram.
- » If the specifications have been met:
 - Check the next possible cause
 - Engine control unit – the ground wire (I) is faulty

Engine control unit – the ground wire (I) is faulty

Condition

- + Engine control unit is disconnected (p. 23)
- + The breakout box is connected to the engine control unit main wiring harness with adapter **00029095016**
- Engine control unit – the ground wire (I) is faulty

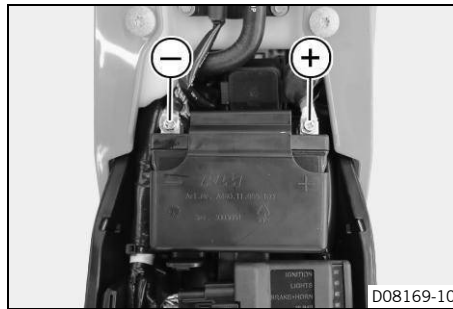
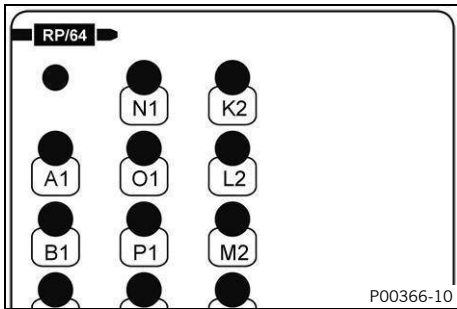

V Voltage measurement points
 Bob box connector **RP** Pin **Q1** – Measuring point **Plus (+)**

The value must not deviate from the battery voltage «**VBAT**» by more than 1 V.

i **Note**
 For the measurement, the measuring points must be subjected to a 12 V/21 W bulb.

- » Specification does not match set value
 - Check Engine control unit connector **RP** (p. 218) pin **Q1**.
 - Check wire from Engine control unit connector **RP** (p. 218) pin **Q1** to the next node in the wiring harness.
- » If the specifications have been met:
 - Check the next possible cause
 Engine control unit – the ground wire (II) is faulty

Engine control unit – the ground wire (II) is faulty

Condition

- + Engine control unit is disconnected (p. 23)
- + The breakout box is connected to the engine control unit main wiring harness with adapter **00029095016**
- Engine control unit – the ground wire (II) is faulty

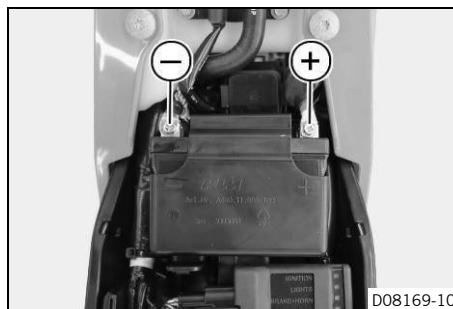
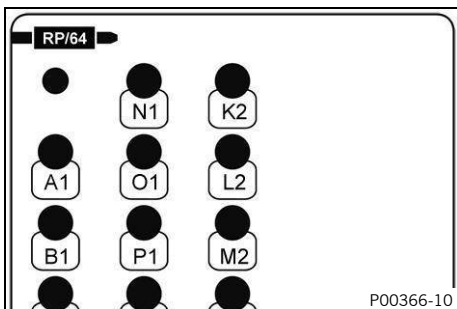

V Voltage measurement points
 Bob box connector **RP** Pin **P1** – Measuring point **Plus (+)**

The value must not deviate from the battery voltage «**VBAT**» by more than 1 V.



i **Note**
 For the measurement, the measuring points must be subjected to a 12 V/21 W bulb.

- » Specification does not match set value
 - Check Engine control unit connector **RP** (p. 218) pin **P1**.
 - Check wire from Engine control unit connector **RP** (p. 218) pin **P1** to the next node in the wiring harness.

3 Engine control trouble code

Last action

- Contact customer service.

Blink code for malfunction indicator light	 21: Malfunction indicator light flashes 2x long, 1x short
Display on diagnostic tool	P056300 «Battery voltage» «Input voltage too high»
Error level condition	Battery voltage – input voltage too high Engine control unit power supply: ≥ 16.10 V Time: ≥ 1 s
Function check	Checking the charging voltage  (p. 125)
Last action	– Contact customer service.

Checking the charging voltage

Condition

+ The 12 V battery must be fully functional and completely charged.

Preparatory work

– Remove the seat.

Control process

– Carry out the starting procedure.

– Take the measurement.

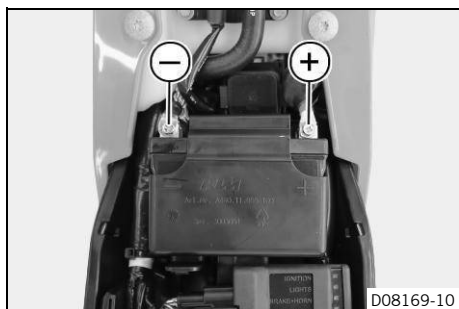

V Voltage measurement points
 Measuring point **Plus (+)** – Measuring point **Ground (-)**

Charging voltage	13.5 V ... 15.0 V
------------------	-------------------

- » If the displayed value is less than the specified value:
 - Check the plug-in connections from the alternator to the regulator rectifier.
 - Check the plug-in connections from the regulator rectifier to the wiring harness.
 - Check the stator winding of the alternator.
- » If the displayed value is greater than the specified value:
 - Change regulator rectifier.





Reworking

– Mount the seat.

Last action



– Contact customer service.

3 Engine control trouble code

Blink code for malfunction indicator light	 53: Malfunction indicator light flashes 5x long, 3x short
Display on diagnostic tool	P064200 «Sensor voltage 1» «Short circuit to ground or open circuit»
Error level condition	Sensor voltage 1 – open circuit/short circuit to ground
Possible cause	Sensor voltage 1 has a short circuit to ground (terminal 31)  (p. 126)
	Sensor voltage 1 has a short circuit to sensor ground  (p. 126)
	Sensor voltage 1 malfunction  (p. 127)
Last action	– Contact customer service.

Sensor voltage 1 has a short circuit to ground (terminal 31)

Condition

- + Diagnostic tool is disconnected
- + Engine control unit is disconnected  (p. 23)
- + The breakout box is connected to the engine control unit main wiring harness with adapter **00029095016**
- + Rollover sensor is disconnected  (p. 23)
- + Crank chamber pressure sensor is disconnected  (p. 18)
- Checking sensor voltage 1 for a short circuit to ground (terminal 31).

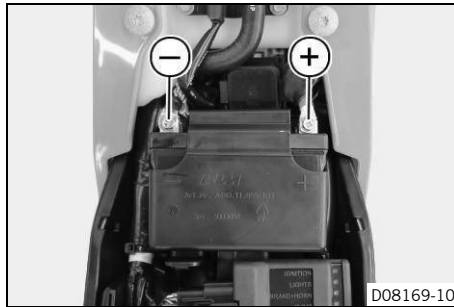
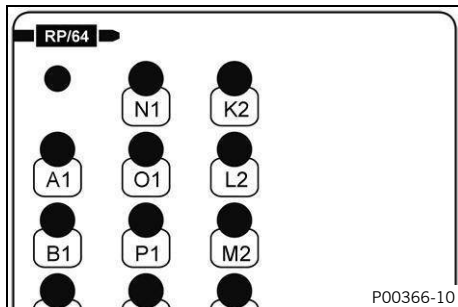

Resistance measurement points



Bob box connector **RP** Pin **D3** – Measuring point **Ground (-)**

Resistance	$\infty \Omega$
------------	-----------------

- » Specification does not match set value
 - Check wire from Engine control unit connector **RP**  (p. 218) pin **D3** against the wiring diagram for a short circuit to ground (clamp 31).
- » If the specifications have been met:
 - Check the next possible cause
Sensor voltage 1 has a short circuit to sensor ground

Sensor voltage 1 has a short circuit to sensor ground

Condition

- + Diagnostic tool is disconnected
- + Engine control unit is disconnected  (p. 23)
- + The breakout box is connected to the engine control unit main wiring harness with adapter **00029095016**
- + Rollover sensor is disconnected  (p. 23)
- + Crank chamber pressure sensor is disconnected  (p. 18)
- Check sensor voltage 1 for a short circuit to sensor ground.

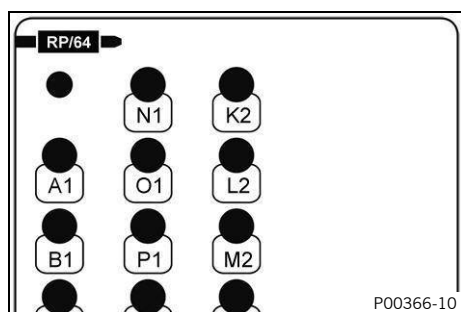

Resistance measurement points

Bob box connector **RP** Pin **D3** – Bob box connector **RP** Pin **C2**

Resistance	$\infty \Omega$
------------	-----------------

- » Specification does not match set value
 - Check wire from Engine control unit connector **RP** (p. 218) pin **D3** against the wiring diagram for a short circuit to sensor ground.
- » If the specifications have been met:
 - Check the next possible cause
Sensor voltage 1 malfunction

Sensor voltage 1 malfunction

Condition

- + Diagnostic tool is connected and active
- + Engine control unit is connected (p. 23)
- + The breakout box is connected to the engine control unit and the main wiring harness with adapter **00029095016**
- Sensor voltage 1 – check the voltage.

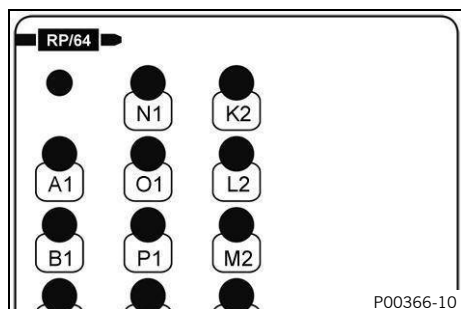

Voltage measurement points

Bob box connector **RP** Pin **D3** – Bob box connector **RP** Pin **C2**





Voltage	4.8 V ... 5.2 V
---------	-----------------

- » Specification does not match set value
 - Check wire from Engine control unit connector **RP** (p. 218) pin **D3** according to the wiring diagram.
 - Check wire from Crankcase pressure sensor connector **LU** (p. 217) pin **2** to Engine control unit connector **RP** (p. 218) pin **C2**.

Last action



- Contact customer service.

3 Engine control trouble code

Blink code for malfunction indicator light	 53: Malfunction indicator light flashes 5x long, 3x short
Display on diagnostic tool	P064300 «Sensor voltage 1» «Short circuit to plus»
Error level condition	Sensor voltage 1 – short circuit to plus
Possible cause	Sensor voltage 1 has a short circuit to plus (terminal 30)  (p. 128)
	Sensor voltage 1 has a short circuit to ignition plus (terminal 15)  (p. 128)
	Sensor voltage 1 malfunction  (p. 127)
Last action	– Contact customer service.

Sensor voltage 1 has a short circuit to plus (terminal 30)

Condition

- + Diagnostic tool is disconnected
- + Engine control unit is disconnected  (p. 23)
- + The breakout box is connected to the engine control unit main wiring harness with adapter **00029095016**
- + Rollover sensor is disconnected  (p. 23)
- + Crank chamber pressure sensor is disconnected  (p. 18)
- Check sensor voltage 1 for a short circuit to plus (terminal 30).

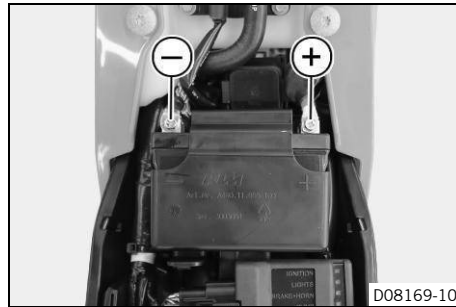
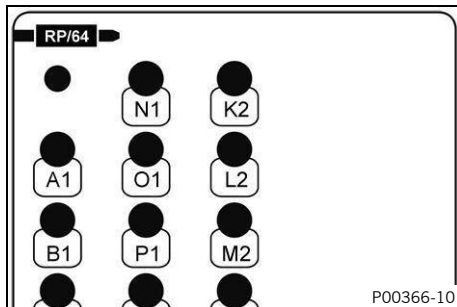



V Voltage measurement points
Bob box connector **RP** Pin **D3** – Measuring point **Ground (-)**

Voltage	< 0.1 V
---------	---------

- » Specification does not match set value
 - Check wire from Engine control unit connector **RP**  (p. 218) pin **D3** against the wiring diagram for a short circuit to plus (terminal 30).
- » If the specifications have been met:
 - Check the next possible cause
Sensor voltage 1 has a short circuit to ignition plus (terminal 15)

Sensor voltage 1 has a short circuit to ignition plus (terminal 15)

Condition

- + Diagnostic tool is disconnected
- + Engine control unit is disconnected  (p. 23)
- + The breakout box is connected to the engine control unit main wiring harness with adapter **00029095016**
- + Rollover sensor is disconnected  (p. 23)
- + Crank chamber pressure sensor is disconnected  (p. 18)
- Check sensor voltage 1 for a short circuit to ignition plus (terminal 15).

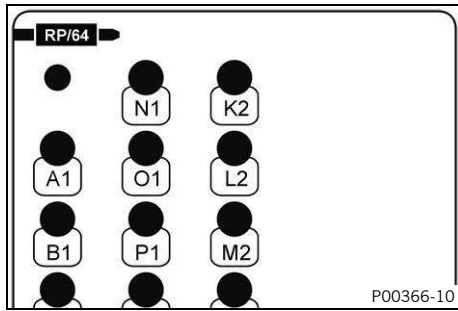

Resistance measurement points

Bob box connector **RP** Pin **D3** – Bob box connector **RP** Pin **D4**

Resistance	$\infty \Omega$
------------	-----------------

- » Specification does not match set value
 - Check wire from Engine control unit connector **RP** (p. 218) pin **D3** against the wiring diagram for a short circuit to ignition positive (clamp 15).
- » If the specifications have been met:
 - Check the next possible cause
Sensor voltage 1 malfunction

Sensor voltage 1 malfunction

Condition

- + Diagnostic tool is connected and active
- + Engine control unit is connected (p. 23)
- + The breakout box is connected to the engine control unit and the main wiring harness with adapter **00029095016**
- Sensor voltage 1 – check the voltage.

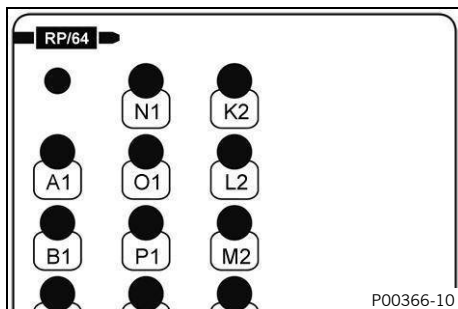

Voltage measurement points

Bob box connector **RP** Pin **D3** – Bob box connector **RP** Pin **C2**





Voltage	4.8 V ... 5.2 V
---------	-----------------

- » Specification does not match set value
 - Check wire from Engine control unit connector **RP** (p. 218) pin **D3** according to the wiring diagram.
 - Check wire from Crankcase pressure sensor connector **LU** (p. 217) pin **2** to Engine control unit connector **RP** (p. 218) pin **C2**.

Last action



- Contact customer service.

3 Engine control trouble code

Blink code for malfunction indicator light	 54: Malfunction indicator light flashes 5x long, 4x short
Display on diagnostic tool	P065200 «Sensor voltage 2» «Short circuit to ground or open circuit»
Error level condition	Sensor voltage 2 – open circuit/short circuit to ground
Possible cause	Sensor voltage 2 has a short circuit to ground (clamp 31)  (p. 130)
	Sensor voltage 2 has a short circuit to sensor ground  (p. 130)
	Sensor voltage 2 malfunction  (p. 131)
Last action	– Contact customer service.

Sensor voltage 2 has a short circuit to ground (clamp 31)

Condition

- + Diagnostic tool is disconnected
- + Engine control unit is disconnected  (p. 23)
- + The breakout box is connected to the engine control unit main wiring harness with adapter **00029095016**
- + Throttle position sensor circuit A is disconnected  (p. 21)
- + Ambient air pressure sensor is disconnected  (p. 22)
- Check sensor voltage 2 for a short circuit to ground (clamp 31)

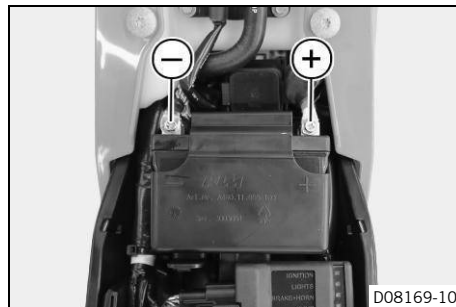
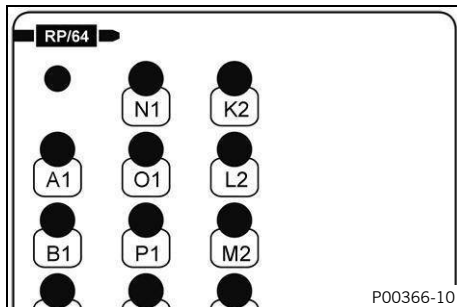



 Resistance measurement points
Bob box connector **RP** Pin **D2** – Measuring point **Ground (-)**

Resistance	$\infty \Omega$
------------	-----------------

- » Specification does not match set value
 - Check wire from Engine control unit connector **RP**  (p. 218) pin **D2** against the wiring diagram for a short circuit to ground (clamp 31).
- » If the specifications have been met:
 - Check the next possible cause
Sensor voltage 2 has a short circuit to sensor ground

Sensor voltage 2 has a short circuit to sensor ground

Condition

- + Diagnostic tool is disconnected
- + Engine control unit is disconnected  (p. 23)
- + The breakout box is connected to the engine control unit main wiring harness with adapter **00029095016**
- + Throttle position sensor circuit A is disconnected  (p. 21)
- + Ambient air pressure sensor is disconnected  (p. 22)
- Check sensor voltage 2 for a short circuit to sensor ground

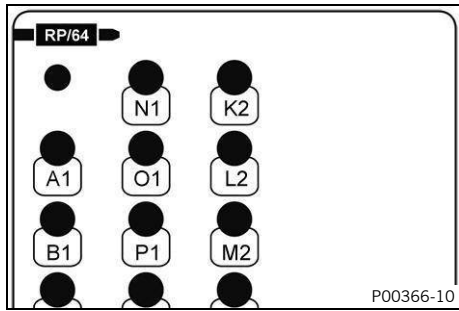

Resistance measurement points

Bob box connector **RP** Pin **D2** – Bob box connector **RP** Pin **E2**

Resistance	$\infty \Omega$
------------	-----------------

- » Specification does not match set value
 - Check wire from Engine control unit connector **RP** (p. 218) pin **D2** against the wiring diagram for a short circuit to sensor ground.
- » If the specifications have been met:
 - Check the next possible cause
Sensor voltage 2 malfunction

Sensor voltage 2 malfunction

Condition

- + Diagnostic tool is connected and active
- + Engine control unit is connected (p. 23)
- + The breakout box is connected to the engine control unit and the main wiring harness with adapter **00029095016**
- Sensor voltage 2 – check the voltage

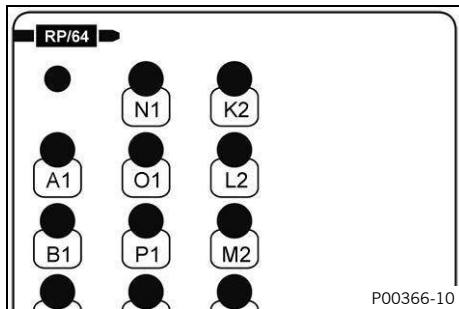

Voltage measurement points

Bob box connector **RP** Pin **D2** – Bob box connector **RP** Pin **E2**





Voltage	4.8 V ... 5.2 V
---------	-----------------

- » Specification does not match set value
 - Check from Engine control unit connector **RP** (p. 218) pin **D2** according to the wiring diagram.
 - Check from Engine control unit connector **RP** (p. 218) pin **E2** according to the wiring diagram.

Last action



- Contact customer service.

3 Engine control trouble code

Blink code for malfunction indicator light	 54: Malfunction indicator light flashes 5x long, 4x short
Display on diagnostic tool	P065300 «Sensor voltage 2» «Short circuit to plus»
Error level condition	Sensor voltage 2 – short circuit to plus
Possible cause	Sensor voltage 2 has a short circuit to plus (clamp 30)  (p. 132)
	Sensor voltage 2 has a short circuit to ignition plus (clamp 15)  (p. 132)
	Sensor voltage 2 malfunction  (p. 131)
Last action	– Contact customer service.

Sensor voltage 2 has a short circuit to plus (clamp 30)

Condition

- + Diagnostic tool is disconnected
- + Engine control unit is disconnected  (p. 23)
- + The breakout box is connected to the engine control unit main wiring harness with adapter **00029095016**
- + Throttle position sensor circuit A is disconnected  (p. 21)
- + Ambient air pressure sensor is disconnected  (p. 22)
- Check sensor voltage 2 for a short circuit to plus (clamp 30)

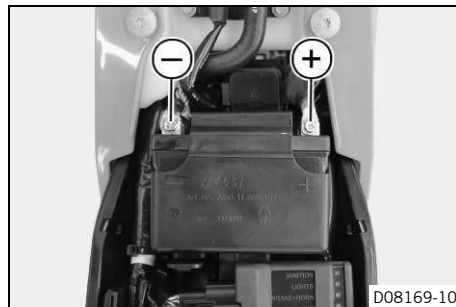
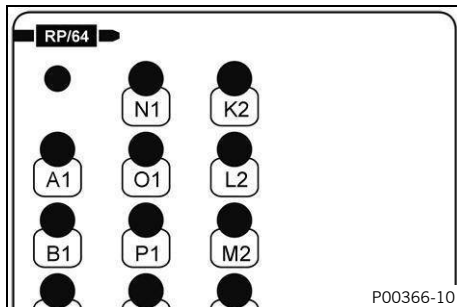



V Voltage measurement points
Bob box connector **RP** Pin **D2** – Measuring point **Ground (-)**

Voltage	< 0.1 V
---------	---------

- » Specification does not match set value
 - Check wire from Engine control unit connector **RP**  (p. 218) pin **D2** against the wiring diagram for a short circuit to plus (terminal 30).
- » If the specifications have been met:
 - Check the next possible cause
Sensor voltage 2 has a short circuit to ignition plus (clamp 15)

Sensor voltage 2 has a short circuit to ignition plus (clamp 15)

Condition

- + Diagnostic tool is disconnected
- + Engine control unit is disconnected  (p. 23)
- + The breakout box is connected to the engine control unit main wiring harness with adapter **00029095016**
- + Throttle position sensor circuit A is disconnected  (p. 21)
- + Ambient air pressure sensor is disconnected  (p. 22)
- Check sensor voltage 2 for a short circuit to ignition plus (clamp 15)

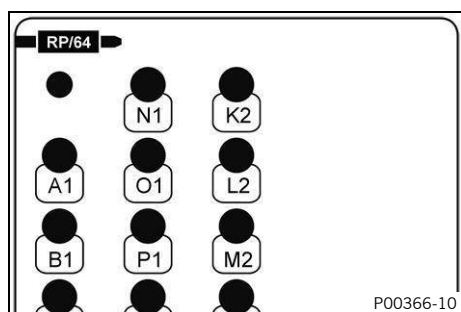

Resistance measurement points
Bob box connector **RP** Pin **D2** – Bob box connector **RP** Pin **D4**

Resistance	$\infty \Omega$
------------	-----------------

- » Specification does not match set value
 - Check wire from Engine control unit connector **RP** (p. 218) pin **D2** against the wiring diagram for a short circuit to ignition positive (clamp 15).
- » If the specifications have been met:
 - Check the next possible cause
Sensor voltage 2 malfunction

Sensor voltage 2 malfunction

Condition

- + Diagnostic tool is connected and active
- + Engine control unit is connected (p. 23)
- + The breakout box is connected to the engine control unit and the main wiring harness with adapter **00029095016**
- Sensor voltage 2 – check the voltage

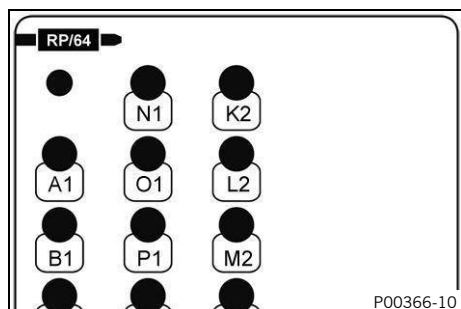

Voltage measurement points
Bob box connector **RP** Pin **D2** – Bob box connector **RP** Pin **E2**





Voltage	4.8 V ... 5.2 V
---------	-----------------

- » Specification does not match set value
 - Check from Engine control unit connector **RP** (p. 218) pin **D2** according to the wiring diagram.
 - Check from Engine control unit connector **RP** (p. 218) pin **E2** according to the wiring diagram.

Last action



- Contact customer service.

3 Engine control trouble code

Blink code for malfunction indicator light	 09: Malfunction indicator light flashes 9x short
Display on diagnostic tool	P110711 «Ambient air pressure sensor» «Short circuit to ground»
Error level condition	Ambient air pressure sensor - short circuit to ground Ambient air pressure sensor voltage: ≤ 0.4 V Time: ≥ 1 s
Function check	Ambient air pressure sensor – check the voltage.  (p. 134)
Possible cause	Ambient air pressure sensor – the power supply is faulty  (p. 135)
	Ambient air pressure sensor – the signal wire has a short circuit to ground (terminal 31)  (p. 135)
	Ambient air pressure sensor – the signal wire has a short circuit to sensor ground  (p. 136)
Last action	– Contact customer service.

Ambient air pressure sensor – check the voltage.

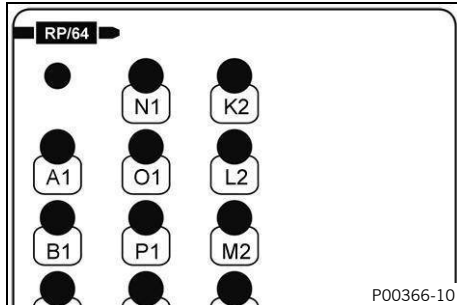

Condition

- + Diagnostic tool is connected and active
- + Engine control unit is connected  (p. 23)
- + The breakout box is connected to the engine control unit main wiring harness with adapter **00029095016**
- + Ambient air pressure sensor is connected  (p. 22)
- Select «**Engine control unit**» > «**Measured values**» > «**Ambient air pressure**».
- Ambient air pressure sensor – check the voltage.



V Voltage measurement points
Bob box connector **RP** Pin **E2** – Bob box connector **RP** Pin **G2**



Ambient air pressure sensor voltage	
at: 133 mbar (1.93 psi)	1 V
at: 957 mbar (13.88 psi)	2.3 V
at: 2,500 mbar (36.26 psi)	4.75 V

- » If the displayed value is equal to the set value:
 - Clear fault memory with diagnostic tool.
 - Take a test ride.
 - Read out the fault memory using the diagnostics tool.
- » If the displayed value is below the setpoint value:
 - Ambient air pressure sensor – the power supply is faulty  (p. 135)
 - Ambient air pressure sensor – the signal wire has a short circuit to ground (terminal 31)  (p. 135)
 - Ambient air pressure sensor – the signal wire has a short circuit to sensor ground  (p. 136)



Ambient air pressure sensor – the power supply is faulty

Condition

- + Diagnostic tool is connected and active
- + Engine control unit is connected  (p. 23)
- + Ambient air pressure sensor is disconnected  (p. 22)
- Ambient air pressure sensor – check the power supply.

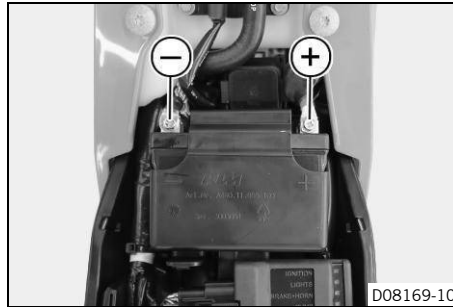
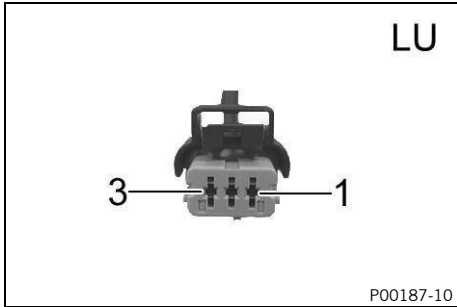

Voltage measurement points



Ambient air pressure sensor connector **LU** Pin **1** – Measuring point **Ground (-)**

Voltage	4.8 V ... 5.2 V
---------	-----------------





Note

For the measurement, the measuring points must be subjected to a 12 V/21 W bulb.

- » Specification does not match set value
 - Check Ambient air pressure sensor connector **LU**  (p. 217) pin **1** and pin **2**.
 - Check wire from Ambient air pressure sensor connector **LU**  (p. 217) pin **1** to the next node in the wiring harness.
 - Check wire from Ambient air pressure sensor connector **LU**  (p. 217) pin **2** to the next node in the wiring harness.
- » If the specifications have been met:
 - Check the next possible cause
 - Ambient air pressure sensor – the signal wire has a short circuit to ground (terminal 31)

Ambient air pressure sensor – the signal wire has a short circuit to ground (terminal 31)

Condition

- + Diagnostic tool is disconnected
- + Engine control unit is disconnected  (p. 23)
- + Ambient air pressure sensor is disconnected  (p. 22)
- Ambient air pressure sensor – check the signal wire for a short circuit to ground (terminal 31).

3 Engine control trouble code

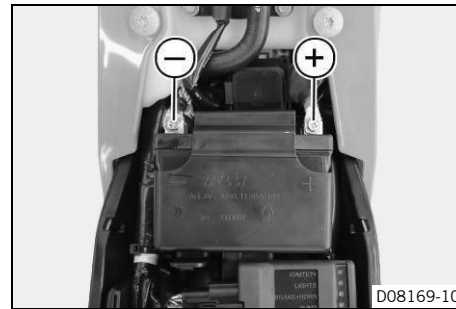
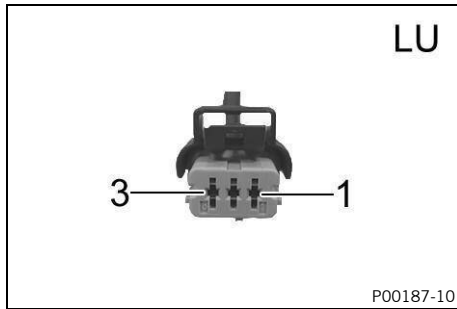

Ω Resistance measurement points
Ambient air pressure sensor connector **LU** Pin **3** – Measuring point **Ground (-)**

Resistance	$\infty \Omega$
------------	-----------------

- » Specification does not match set value
 - Check wire from Ambient air pressure sensor connector **LU** (p. 217) pin **3** to Engine control unit connector **RP** (p. 218) pin **G2** for a short circuit to ground (clamp 31).
- » If the specifications have been met:
 - Check the next possible cause
Ambient air pressure sensor – the signal wire has a short circuit to sensor ground

Ambient air pressure sensor – the signal wire has a short circuit to sensor ground

Condition

- + Diagnostic tool is disconnected
- + Engine control unit is disconnected (p. 23)
- + Ambient air pressure sensor is disconnected (p. 22)
- Ambient air pressure sensor – check the signal wire for a short circuit to sensor ground.

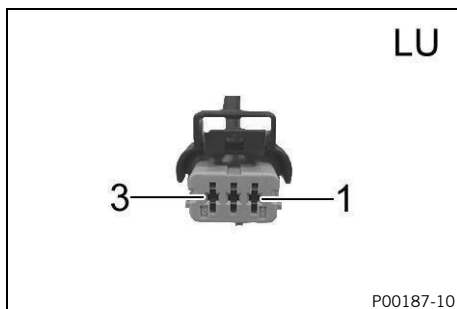







Ω Resistance measurement points
Ambient air pressure sensor connector **LU** Pin **3** – Ambient air pressure sensor connector **LU** Pin **2**

Resistance	$\infty \Omega$
------------	-----------------

- » Specification does not match set value
 - Check wire from Ambient air pressure sensor connector **LU** (p. 217) pin **3** to Engine control unit connector **RP** (p. 218) pin **G2** for a short circuit to sensor ground.



Last action

- Contact customer service.

Blink code for malfunction indicator light	 09: Malfunction indicator light flashes 9x short
Display on diagnostic tool	P110812 «Ambient air pressure sensor» «Open/short circuit to plus»
Error level condition	Ambient air pressure sensor – open/short circuit to plus Ambient air pressure sensor voltage: ≥ 4.6 V Time: ≥ 0.1 s
Function check	Ambient air pressure sensor – check the voltage.  (p. 137)
Possible cause	Ambient air pressure sensor – the signal wire is faulty  (p. 138)
	Ambient air pressure sensor – the ground wire is faulty  (p. 138)
	Ambient air pressure sensor – the signal wire has a short circuit to plus (terminal 30)  (p. 139)
	Ambient air pressure sensor – the signal wire has a short circuit to ignition plus (terminal 15)  (p. 140)
	Ambient air pressure sensor – the signal wire has a short circuit to the sensor power supply  (p. 140)
Last action	– Contact customer service.

Ambient air pressure sensor – check the voltage.

Condition

- + Diagnostic tool is connected and active
- + Engine control unit is connected  (p. 23)
- + The breakout box is connected to the engine control unit main wiring harness with adapter **00029095016**
- + Ambient air pressure sensor is connected  (p. 22)
- Select «**Engine control unit**» > «**Measured values**» > «**Ambient air pressure**».
- Ambient air pressure sensor – check the voltage.

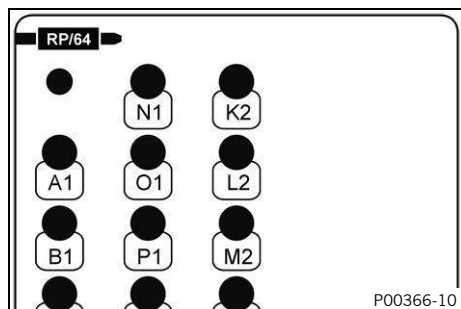



V Voltage measurement points
Bob box connector **RP** Pin **E2** – Bob box connector **RP** Pin **G2**

Ambient air pressure sensor voltage	
at: 133 mbar (1.93 psi)	1 V
at: 957 mbar (13.88 psi)	2.3 V
at: 2,500 mbar (36.26 psi)	4.75 V

- » If the displayed value is equal to the set value:
 - Clear fault memory with diagnostic tool.
 - Take a test ride.
 - Read out the fault memory using the diagnostics tool.
- » If the displayed value is above the setpoint value:
Ambient air pressure sensor – the signal wire is faulty  (p. 138)

3 Engine control trouble code

Ambient air pressure sensor – the ground wire is faulty  (p. 138)



Ambient air pressure sensor – the signal wire has a short circuit to plus (terminal 30)  (p. 139)

Ambient air pressure sensor – the signal wire has a short circuit to ignition plus (terminal 15)  (p. 140)

Ambient air pressure sensor – the signal wire has a short circuit to the sensor power supply  (p. 140)

Ambient air pressure sensor – the signal wire is faulty

Condition



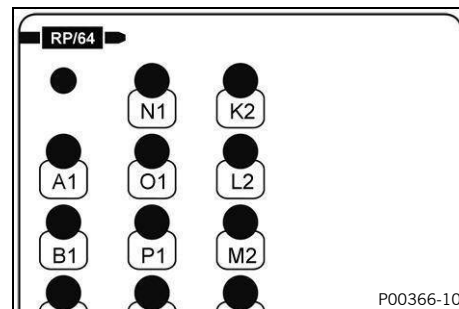
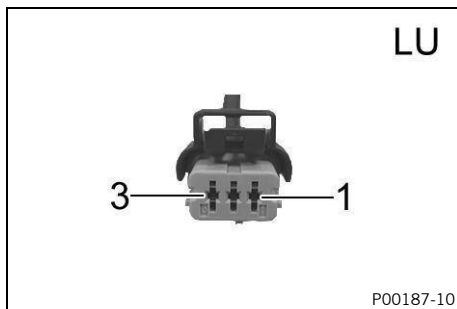

- + Diagnostic tool is disconnected
- + Engine control unit is disconnected  (p. 23)
- + The breakout box is connected to the engine control unit main wiring harness with adapter **00029095016**
- + Ambient air pressure sensor is disconnected  (p. 22)
- Ambient air pressure sensor – check the signal wire.



Resistance measurement points



Bob box connector **RP** Pin **G2** – Ambient air pressure sensor connector **LU** Pin **3**

Resistance	$\leq 0.6 \Omega$
------------	-------------------

- » Specification does not match set value
 - Check Engine control unit connector **RP**  (p. 218) pin **G2** and Ambient air pressure sensor connector **LU**  (p. 217) pin **3**.
 - Check wire from Engine control unit connector **RP**  (p. 218) pin **G2** to Ambient air pressure sensor connector **LU**  (p. 217) pin **3**.
- » If the specifications have been met:
 - Check the next possible cause
 - Ambient air pressure sensor – the ground wire is faulty

Ambient air pressure sensor – the ground wire is faulty

Condition

- + Diagnostic tool is disconnected
- + Engine control unit is disconnected  (p. 23)
- + The breakout box is connected to the engine control unit main wiring harness with adapter **00029095016**
- + Ambient air pressure sensor is disconnected  (p. 22)
- + Throttle position sensor circuit A is disconnected  (p. 21)
- Ambient air pressure sensor – check the ground wire.

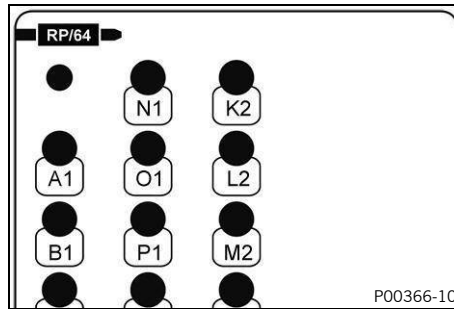
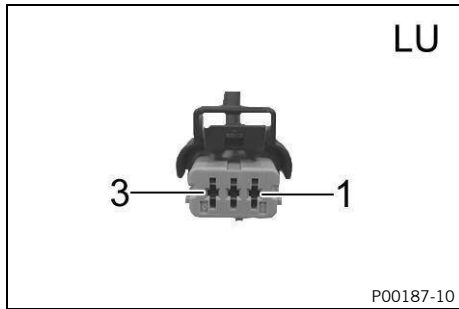

Resistance measurement points

Bob box connector **RP** Pin **E2** – Ambient air pressure sensor connector **LU** Pin **2**

Resistance	$\leq 0.6 \Omega$
------------	-------------------

- » Specification does not match set value
 - Check Engine control unit connector **RP** (p. 218) pin **E2** and Ambient air pressure sensor connector **LU** (p. 217) pin **2**.
 - Check wire from Engine control unit connector **RP** (p. 218) pin **E2** to Ambient air pressure sensor connector **LU** (p. 217) pin **2**.
- » If the specifications have been met:
 - Check the next possible cause
Ambient air pressure sensor – the signal wire has a short circuit to plus (terminal 30)

Ambient air pressure sensor – the signal wire has a short circuit to plus (terminal 30)

Condition

- + Diagnostic tool is disconnected
- + Engine control unit is disconnected (p. 23)
- + The breakout box is connected to the engine control unit main wiring harness with adapter **00029095016**
- + Ambient air pressure sensor is disconnected (p. 22)
- Ambient air pressure sensor – check the signal wire for a short circuit to plus (terminal 30).

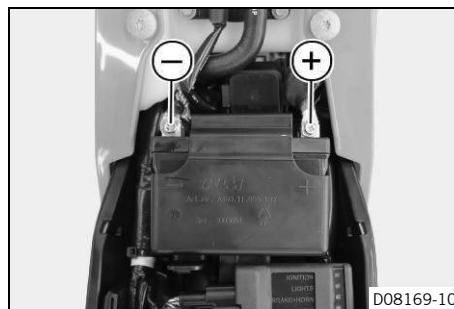
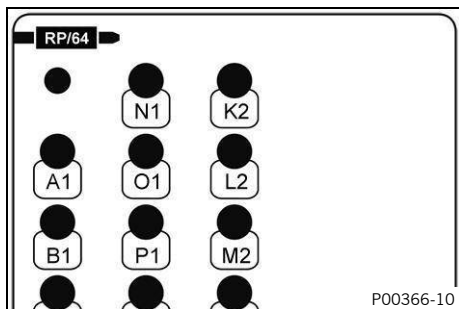

Voltage measurement points

Bob box connector **RP** Pin **G2** – Measuring point **Ground (-)**



Voltage	$< 0.1 V$
---------	-----------

- » Specification does not match set value
 - Check wire from Engine control unit connector **RP** (p. 218) pin **G2** to Ambient air pressure sensor connector **LU** (p. 217) pin **3** for a short circuit to plus (clamp 30).
- » If the specifications have been met:
 - Check the next possible cause
Ambient air pressure sensor – the signal wire has a short circuit to ignition plus (terminal 15)

3 Engine control trouble code

Ambient air pressure sensor – the signal wire has a short circuit to ignition plus (terminal 15)

Condition

- + Diagnostic tool is disconnected
- + Engine control unit is disconnected  (p. 23)
- + The breakout box is connected to the engine control unit main wiring harness with adapter **00029095016**
- + Ambient air pressure sensor is disconnected  (p. 22)
- Ambient air pressure sensor – check the signal wire for a short circuit to ignition plus (terminal 15).

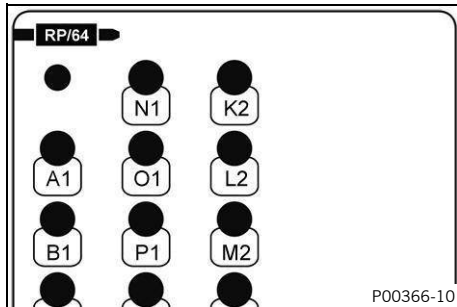



Resistance measurement points

Bob box connector **RP** Pin **G2** – Bob box connector **RP** Pin **D4**



Resistance

$\infty \Omega$

- » Specification does not match set value
 - Check wire from Engine control unit connector **RP**  (p. 218) pin **G2** to Ambient air pressure sensor connector **LU**  (p. 217) pin **3** for a short circuit to ignition plus (clamp 15).
- » If the specifications have been met:
 - Check the next possible cause
 - Ambient air pressure sensor – the signal wire has a short circuit to the sensor power supply

Ambient air pressure sensor – the signal wire has a short circuit to the sensor power supply

Condition

- + Diagnostic tool is disconnected
- + Engine control unit is disconnected  (p. 23)
- + The breakout box is connected to the engine control unit main wiring harness with adapter **00029095016**
- + Ambient air pressure sensor is disconnected  (p. 22)
- Ambient air pressure sensor – check the signal wire for a short circuit to the sensor power supply.

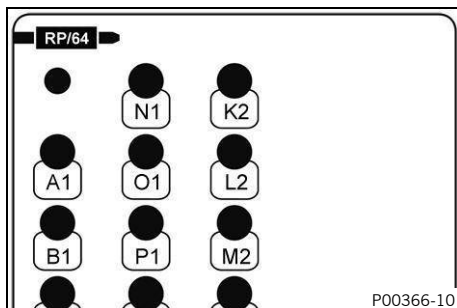



Resistance measurement points

Bob box connector **RP** Pin **G2** – Bob box connector **RP** Pin **D2**



Resistance

$\infty \Omega$

- » Specification does not match set value
 - Check wire from Engine control unit connector **RP**  (p. 218) pin **G2** to Ambient air pressure sensor connector **LU**  (p. 217) pin **3** for a short circuit to the sensor voltage supply.



Last action

- Contact customer service.

Blink code for malfunction indicator light	 50: Malfunction indicator light flashes 5x long
Display on diagnostic tool	P140211 «Exhaust control actuator» «Input signal too low»
Error level condition	Exhaust control actuator – input signal too low
Possible cause	Exhaust control actuator – the control wire has a short circuit to ground (terminal 31)  (p. 141)
	Fuel pump – the control wire has a short circuit to sensor ground  (p. 141)
Last action	– Contact customer service.

Exhaust control actuator – the control wire has a short circuit to ground (terminal 31)

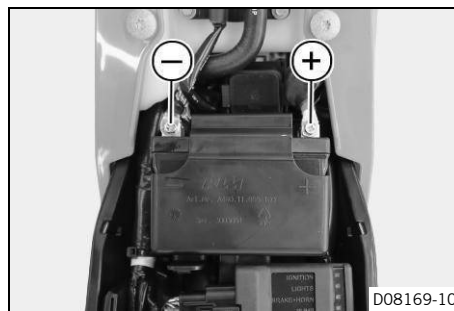
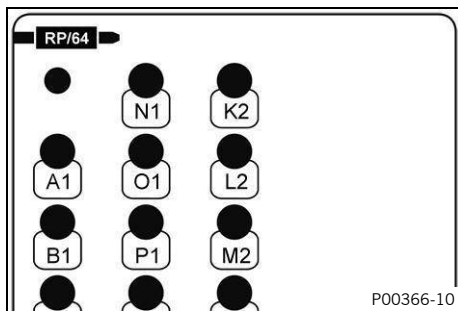

Condition

- + Diagnostic tool is disconnected
- + Engine control unit is disconnected  (p. 23)
- + The breakout box is connected to the engine control unit main wiring harness with adapter **00029095016**
- + Exhaust control actuator is disconnected  (p. 24)
- Exhaust control actuator – check the control wire for a short circuit to ground (terminal 31).





 Resistance measurement points
Bob box connector **RP** Pin **P2** – Measuring point **Ground (-)**

Resistance	$\infty \Omega$
------------	-----------------

- » Specification does not match set value
 - Check wire from Engine control unit connector **RP**  (p. 218) pin **P2** to Exhaust control actuator socket connector **ON**  (p. 218) pin **2** for a short circuit to ground (clamp 31).
- » If the specifications have been met:
 - Check the next possible cause
Fuel pump – the control wire has a short circuit to sensor ground

Fuel pump – the control wire has a short circuit to sensor ground

Condition

- + Diagnostic tool is disconnected
- + Engine control unit is disconnected  (p. 23)
- + The breakout box is connected to the engine control unit main wiring harness with adapter **00029095016**
- + Exhaust control actuator is disconnected  (p. 24)
- Exhaust control actuator – check the control wire for a short circuit to sensor ground.

3 Engine control trouble code

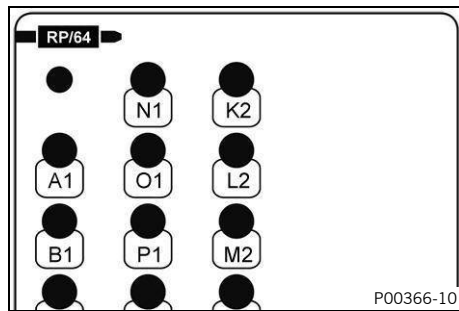

Resistance measurement points





Bob box connector **RP** Pin **P2** – Bob box connector **RP** Pin **E2**

Resistance	$\infty \Omega$
------------	-----------------

- » Specification does not match set value
 - Check wire from Engine control unit connector **RP** (p. 218) pin **P2** to Exhaust control actuator socket connector **ON** (p. 218) pin **2** for a short circuit to sensor ground.



Last action

- Contact customer service.

Blink code for malfunction indicator light	 50: Malfunction indicator light flashes 5x long
Display on diagnostic tool	P140312 «Exhaust control actuator» «Input signal too high»
Error level condition	Exhaust control actuator – input signal too high
Possible cause	Exhaust control actuator – control wire is faulty  (p. 143) Exhaust control actuator – the control wire has a short circuit to plus (terminal 30)  (p. 143) Exhaust control actuator – the control wire has a short circuit to ignition plus (terminal 15)  (p. 144) Exhaust control actuator – control wire has a short circuit to the sensor power supply  (p. 145)
Last action	– Contact customer service.

Exhaust control actuator – control wire is faulty

Condition



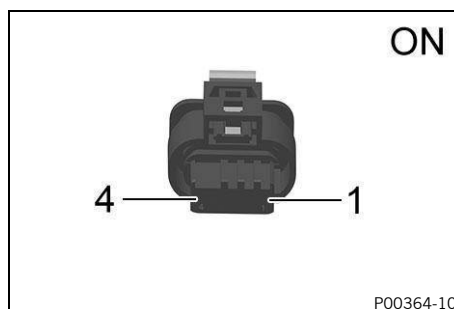
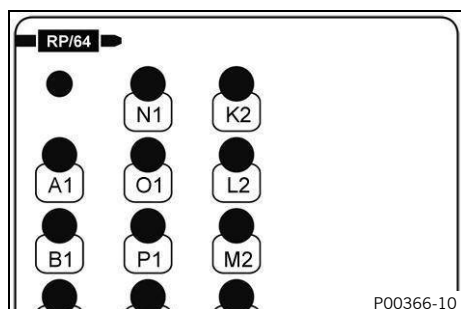

- + Diagnostic tool is disconnected
- + Engine control unit is disconnected  (p. 23)
- + The breakout box is connected to the engine control unit main wiring harness with adapter **00029095016**
- + Exhaust control actuator is disconnected  (p. 24)
- Exhaust control actuator – check the control wire.



Resistance measurement points

Bob box connector **RP** Pin **P2** – Exhaust control actuator socket connector **ON** Pin **2**

Resistance	≤ 0.6 Ω
------------	---------



- » Specification does not match set value
 - Check Engine control unit connector **RP**  (p. 218) pin **P2** and Exhaust control actuator socket connector **ON**  (p. 218) pin **2**.
 - Check wire from Engine control unit connector **RP**  (p. 218) pin **P2** to Exhaust control actuator socket connector **ON**  (p. 218) pin **2**.
- » If the specifications have been met:
 - Check the next possible cause
Exhaust control actuator – the control wire has a short circuit to plus (terminal 30)

Exhaust control actuator – the control wire has a short circuit to plus (terminal 30)

Condition

- + Diagnostic tool is disconnected

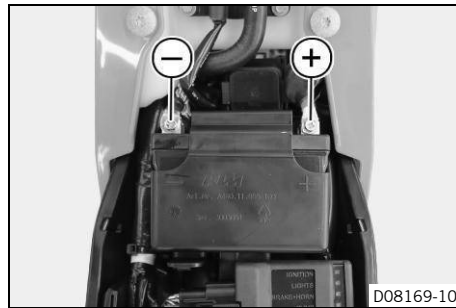
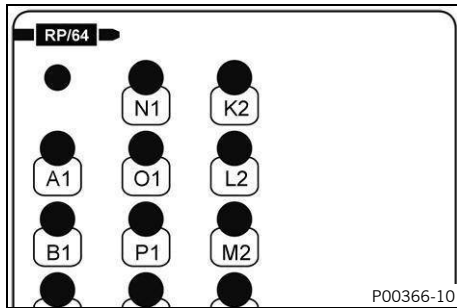

3 Engine control trouble code

- + Engine control unit is disconnected  (p. 23)
- + The breakout box is connected to the engine control unit main wiring harness with adapter **00029095016**
- + Exhaust control actuator is disconnected  (p. 24)
- Exhaust control actuator – check the control wire for a short circuit to plus (terminal 30).





V Voltage measurement points
Bob box connector **RP** Pin **P2** – Measuring point **Ground (-)**

Voltage	< 0.1 V
---------	---------

- » Specification does not match set value
 - Check wire from Engine control unit connector **RP**  (p. 218) pin **P2** to Exhaust control actuator socket connector **ON**  (p. 218) pin **2** for a short circuit to plus (clamp 30).
- » If the specifications have been met:
 - Check the next possible cause
Exhaust control actuator – the control wire has a short circuit to ignition plus (terminal 15)

Exhaust control actuator – the control wire has a short circuit to ignition plus (terminal 15)

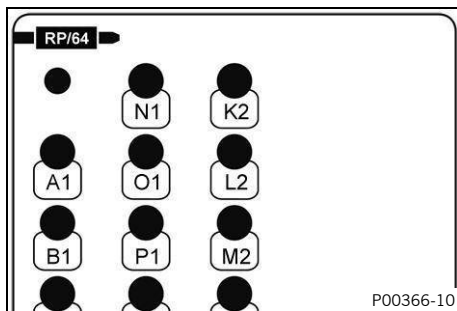

Condition

- + Diagnostic tool is disconnected
- + Engine control unit is disconnected  (p. 23)
- + The breakout box is connected to the engine control unit main wiring harness with adapter **00029095016**
- + Exhaust control actuator is disconnected  (p. 24)
- Exhaust control actuator – check the control wire for a short circuit to ignition plus (terminal 15).





Ω Resistance measurement points
Bob box connector **RP** Pin **P2** – Bob box connector **RP** Pin **D4**

Resistance	$\infty \Omega$
------------	-----------------

- » Specification does not match set value
 - Check wire from Engine control unit connector **RP**  (p. 218) pin **P2** to Exhaust control actuator socket connector **ON**  (p. 218) pin **2** for a short circuit to ignition plus (clamp 15).
- » If the specifications have been met:
 - Check the next possible cause
Exhaust control actuator – control wire has a short circuit to the sensor power supply

Exhaust control actuator – control wire has a short circuit to the sensor power supply

Condition

- + Diagnostic tool is disconnected
- + Engine control unit is disconnected  (p. 23)
- + The breakout box is connected to the engine control unit main wiring harness with adapter **00029095016**
- + Exhaust control actuator is disconnected  (p. 24)
- Exhaust control actuator – check the control wire for a short circuit to the sensor power supply.

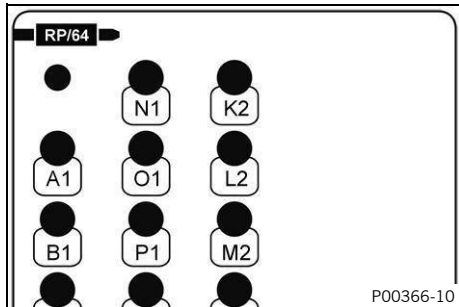

 Resistance measurement points
 Bob box connector **RP** Pin **P2** – Bob box connector **RP** Pin **D3**



Resistance	$\infty \Omega$
------------	-----------------

- » Specification does not match set value
 - Check wire from Engine control unit connector **RP**  (p. 218) pin **P2** to Exhaust control actuator socket connector **ON**  (p. 218) pin **2** for a short circuit to the sensor voltage supply.

Last action

- Contact customer service.

3 Engine control trouble code

Blink code for malfunction indicator light	 50: Malfunction indicator light flashes 5x long
Display on diagnostic tool	P140477 «Exhaust control actuator» «Mechanical error in the lower position»
Error level condition	Exhaust control actuator – mechanical error in the lower position
Function check	Calibrating the exhaust control actuator  (p. 146)
Last action	– Change exhaust control actuator.

Calibrating the exhaust control actuator

Condition

+ Diagnostic tool is connected and active

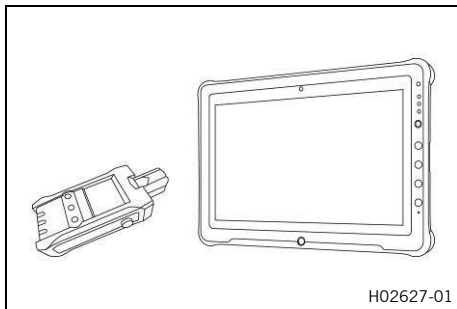

- Execute «**Engine control unit**» > «**Control unit functions**» > «**Teach in exhaust control actuator**».





Note

The instructions must be followed precisely.

- » If the specified value is reached:
 - Clear fault memory with diagnostic tool.
 - Take a test ride.
 - Read out the fault memory using the diagnostics tool.

Last action

- Change exhaust control actuator.

Blink code for malfunction indicator light	 50: Malfunction indicator light flashes 5x long
Display on diagnostic tool	P140577 «Exhaust control actuator» «Mechanical error in the upper position»
Error level condition	Exhaust control actuator – mechanical error in the upper position
Function check	Calibrating the exhaust control actuator  (p. 147)
Last action	– Change exhaust control actuator.

Calibrating the exhaust control actuator

Condition

- + Diagnostic tool is connected and active

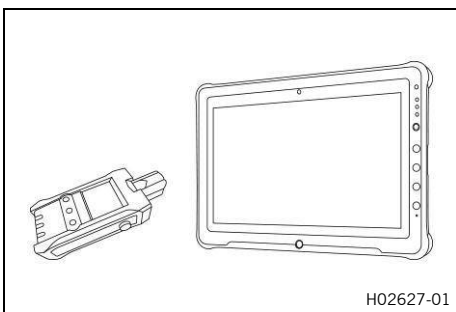

- Execute «**Engine control unit**» > «**Control unit functions**» > «**Teach in exhaust control actuator**».



Note



The instructions must be followed precisely.

- » If the specified value is reached:
 - Clear fault memory with diagnostic tool.
 - Take a test ride.
 - Read out the fault memory using the diagnostics tool.

Last action

- Change exhaust control actuator.

3 Engine control trouble code

Blink code for malfunction indicator light	 50: Malfunction indicator light flashes 5x long
Display on diagnostic tool	P140677 «Exhaust control actuator» «Mechanical error»
Error level condition	Exhaust control actuator – mechanical error
Function check	Checking the exhaust control actuator  (p. 148)
Possible cause	Exhaust control actuator has no function  (p. 148)
Last action	– Contact customer service.

Checking the exhaust control actuator

Condition

+ Diagnostic tool is connected and active

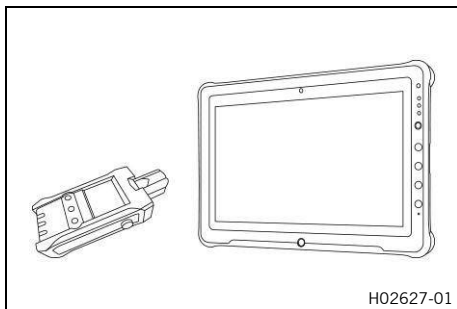

- Execute «**Engine control unit**» > «**Actuator test**» > «**Exhaust control actuator**».

The exhaust control actuator audibly moves from the lower to upper stop position.





- » If the specified value is reached:
 - Clear fault memory with diagnostic tool.
 - Take a test ride.
 - Read out the fault memory using the diagnostics tool.
- » If the specification is not reached:
Exhaust control actuator has no function  (p. 148)

Exhaust control actuator has no function

- Check the exhaust control actuator for mechanical damage.
 - » Specification does not match set value
 - Change exhaust control actuator.



Last action

- Contact customer service.

Blink code for malfunction indicator light	 15: Failure indicator light flashes 1x long, 5x short
Display on diagnostic tool	P163100 «Tilt sensor» «Input signal too low»
Error level condition	Tilt sensor – input signal too low Signal voltage: ≤ 0.2 V Signal voltage: 3.7 V ... 4.6 V
Possible cause	Tilt sensor – the power supply is faulty  (p. 149)
	Tilt sensor – the signal wire has a short circuit to ground (terminal 31)  (p. 150)
	Tilt sensor – the signal wire has a short circuit to sensor ground  (p. 150)
Last action	– Contact customer service.

Tilt sensor – the power supply is faulty

Condition



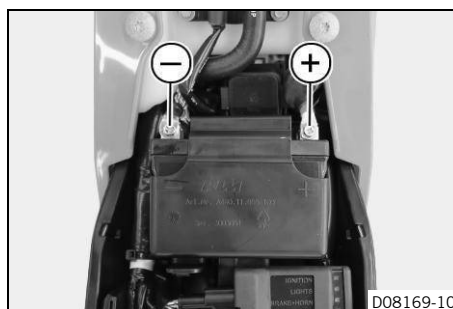
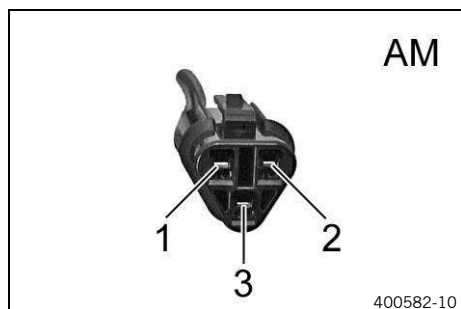

- + Diagnostic tool is connected and active
- + Engine control unit is connected  (p. 23)
- + Rollover sensor is disconnected  (p. 23)
- Tilt sensor – check the power supply.



V Voltage measurement points
 Tilt sensor connector **AM** Pin **2** – Measuring point **Ground (-)**

Voltage	4.8 V ... 5.2 V
---------	-----------------



i Note
 For the measurement, the measuring points must be subjected to a 12 V/21 W bulb.

- » Specification does not match set value
 - Check Tilt sensor connector **AM**  (p. 212) pin **2** and pin **1**.
 - Check the wire from Tilt sensor connector **AM**  (p. 212) pin **2** to the next node in the wiring harness.
 - Check wire from Engine control unit connector **RP**  (p. 218) pin **J1** to Tilt sensor connector **AM**  (p. 212) pin **1**.
- » If the specifications have been met:
 - Check the next possible cause
 Tilt sensor – the signal wire has a short circuit to ground (terminal 31)

3 Engine control trouble code

Tilt sensor – the signal wire has a short circuit to ground (terminal 31)

Condition

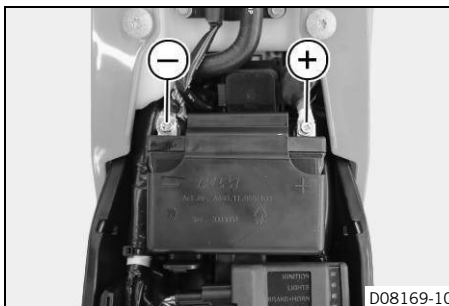
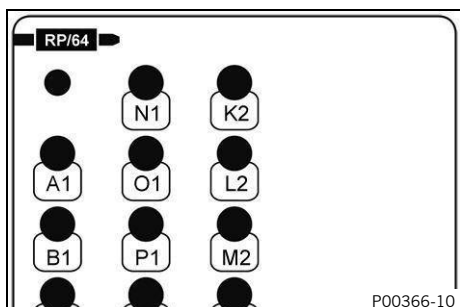

- + Diagnostic tool is disconnected
- + Engine control unit is disconnected  (p. 23)
- + The breakout box is connected to the engine control unit main wiring harness with adapter **00029095016**
- + Rollover sensor is disconnected  (p. 23)
- Side stand sensor – check the signal wire for a short circuit to ground (terminal 31).



Resistance measurement points



Bob box connector **RP** Pin **L2** – Measuring point **Ground (-)**

Resistance	$\infty \Omega$
------------	-----------------

- » Specification does not match set value
 - Check wire from Engine control unit connector **RP**  (p. 218) pin **L2** to Tilt sensor connector **AM**  (p. 212) pin **3** for a short circuit to ground (clamp 31).
- » If the specifications have been met:
 - Check the next possible cause
Tilt sensor – the signal wire has a short circuit to sensor ground

Tilt sensor – the signal wire has a short circuit to sensor ground

Condition

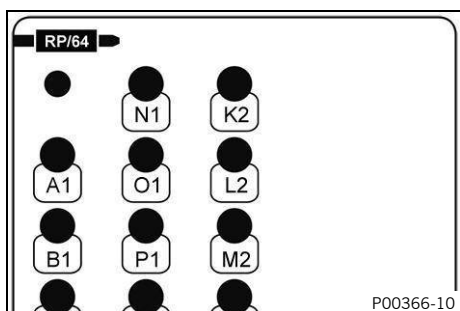

- + Diagnostic tool is disconnected
- + Engine control unit is disconnected  (p. 23)
- + The breakout box is connected to the engine control unit main wiring harness with adapter **00029095016**
- + Rollover sensor is disconnected  (p. 23)
- Tilt sensor – check the signal wire for a short circuit to sensor ground.



Resistance measurement points

Bob box connector **RP** Pin **L2** – Bob box connector **RP** Pin **J1**







Resistance	$\infty \Omega$
------------	-----------------

- » Specification does not match set value
 - Check wire from Engine control unit connector **RP**  (p. 218) pin **L2** to Tilt sensor connector **AM**  (p. 212) pin **3** for a short circuit to sensor ground.

Last action



- Contact customer service.

3 Engine control trouble code

Blink code for malfunction indicator light	 15: Failure indicator light flashes 1x long, 5x short
Display on diagnostic tool	P163200 «Tilt sensor» «Input signal too high»
Error level condition	Tilt sensor – input signal too high Voltage: ≥ 4.8 V
Possible cause	Tilt sensor – the signal wire has a short circuit to plus (terminal 30)  (p. 152) Tilt sensor – the signal wire has a short circuit to ignition plus (terminal 15)  (p. 152) Tilt sensor – the signal wire has a short circuit to the sensor power supply  (p. 153) Tilt sensor – the signal wire is faulty  (p. 153) Tilt sensor – the ground wire is faulty  (p. 154)
Last action	– Contact customer service.

Tilt sensor – the signal wire has a short circuit to plus (terminal 30)

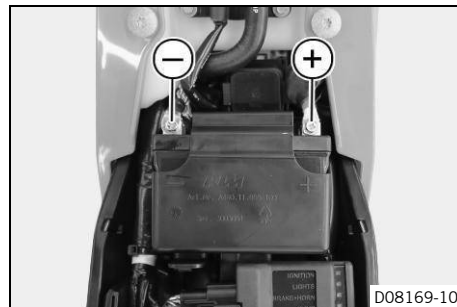
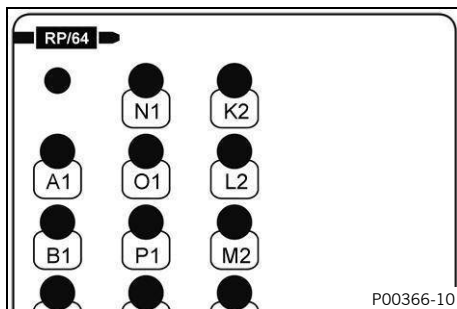

Condition

- + Diagnostic tool is disconnected
- + Engine control unit is disconnected  (p. 23)
- + The breakout box is connected to the engine control unit main wiring harness with adapter **00029095016**
- + Rollover sensor is disconnected  (p. 23)
- Tilt sensor – check the signal wire for a short circuit to plus (terminal 30).



V Voltage measurement points
Bob box connector **RP** Pin **L2** – Measuring point **Ground (-)**

Voltage	< 0.1 V
---------	---------

- » Specification does not match set value
 - Check wire from Engine control unit connector **RP**  (p. 218) pin **L2** to Tilt sensor connector **AM**  (p. 212) pin **3** for a short circuit to plus (clamp 30).
- » If the specifications have been met:
 - Check the next possible cause
Tilt sensor – the signal wire has a short circuit to ignition plus (terminal 15)

Tilt sensor – the signal wire has a short circuit to ignition plus (terminal 15)

Condition

- + Diagnostic tool is disconnected
- + Engine control unit is disconnected  (p. 23)

- + The breakout box is connected to the engine control unit main wiring harness with adapter **00029095016**
- + Rollover sensor is disconnected (p. 23)
- Tilt sensor – check the signal wire for a short circuit to ignition plus (terminal 15).

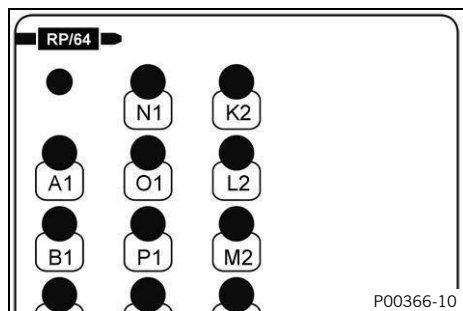

Ω Resistance measurement points
Bob box connector **RP** Pin **L2** – Bob box connector **RP** Pin **D4**

Resistance	$\infty \Omega$
------------	-----------------

- » Specification does not match set value
 - Check wire from Engine control unit connector **RP** (p. 218) pin **L2** to Tilt sensor connector **AM** (p. 212) pin **3** for a short circuit to ignition plus (clamp 15).
- » If the specifications have been met:
 - Check the next possible cause
Tilt sensor – the signal wire has a short circuit to the sensor power supply

Tilt sensor – the signal wire has a short circuit to the sensor power supply

Condition

- + Diagnostic tool is disconnected
- + Engine control unit is disconnected (p. 23)
- + The breakout box is connected to the engine control unit main wiring harness with adapter **00029095016**
- + Rollover sensor is disconnected (p. 23)
- Tilt sensor – check the signal wire for a short circuit to the sensor power supply.

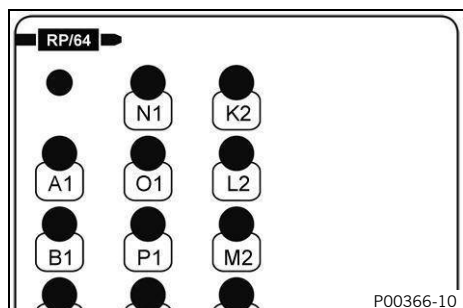

Ω Resistance measurement points
Bob box connector **RP** Pin **L2** – Bob box connector **RP** Pin **D3**

Resistance	$\infty \Omega$
------------	-----------------

- » Specification does not match set value
 - Check wire from Engine control unit connector **RP** (p. 218) pin **L2** to Tilt sensor connector **AM** (p. 212) pin **3** for a short circuit to the sensor voltage supply.
- » If the specifications have been met:
 - Check the next possible cause
Tilt sensor – the signal wire is faulty

Tilt sensor – the signal wire is faulty

Condition

- + Diagnostic tool is disconnected
- + Engine control unit is disconnected (p. 23)

3 Engine control trouble code



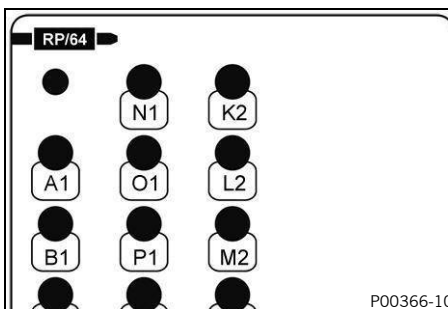
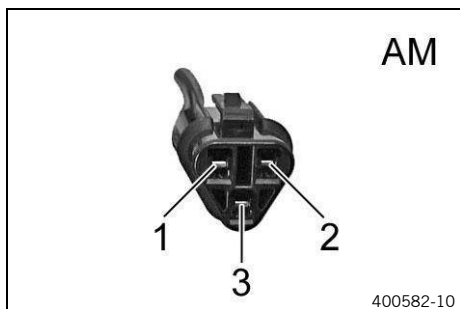

- + The breakout box is connected to the engine control unit main wiring harness with adapter **00029095016**
- + Rollover sensor is disconnected  (p. 23)
- Tilt sensor – check the signal wire.



Resistance measurement points



Bob box connector **RP** Pin **L2** – Tilt sensor connector **AM** Pin **3**

Resistance	$\leq 0.6 \Omega$
------------	-------------------

- » Specification does not match set value
 - Check Engine control unit connector **RP**  (p. 218) pin **L2** and Tilt sensor connector **AM**  (p. 212) pin **3**.
 - Check wire from Engine control unit connector **RP**  (p. 218) pin **L2** to Tilt sensor connector **AM**  (p. 212) pin **3**.
- » If the specifications have been met:
 - Check the next possible cause
Tilt sensor – the ground wire is faulty

Tilt sensor – the ground wire is faulty

Condition

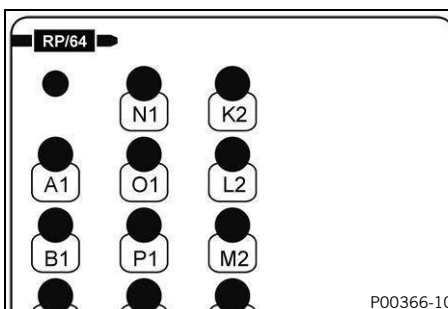
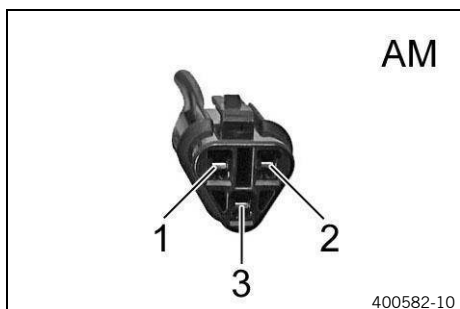

- + Diagnostic tool is disconnected
- + Engine control unit is disconnected  (p. 23)
- + The breakout box is connected to the engine control unit main wiring harness with adapter **00029095016**
- + Rollover sensor is disconnected  (p. 23)
- + Crank chamber pressure sensor is disconnected  (p. 18)
- Tilt sensor – check the ground wire.





Resistance measurement points

Bob box connector **RP** Pin **J1** – Tilt sensor connector **AM** Pin **1**

Resistance	$\leq 0.6 \Omega$
------------	-------------------







- » Specification does not match set value
 - Check Engine control unit connector **RP**  (p. 218) pin **J1** and Tilt sensor connector **AM**  (p. 212) pin **1**.

- Check wire from Engine control unit connector **RP**  (p. 218) pin **J1** to Tilt sensor connector **AM**  (p. 212) pin **1**.

Last action



- Contact customer service.

3 Engine control trouble code

Blink code for malfunction indicator light	 42: Malfunction indicator light flashes 4x long, 2x short
Display on diagnostic tool	P250C11 «Oil level sensor» «Short circuit to ground»
Error level condition	Oil level sensor – short circuit to ground
Possible cause	Oil level sensor – the power supply is faulty  (p. 156)
	Oil level sensor – the signal wire is faulty  (p. 157)
	Oil level sensor – the ground wire is faulty  (p. 157)
	Oil level sensor – the signal wire has a short circuit to ground (terminal 31)  (p. 158)
	Oil level sensor – the signal wire has a short circuit to sensor ground  (p. 158)
Last action	– Contact customer service.

Oil level sensor – the power supply is faulty

Condition



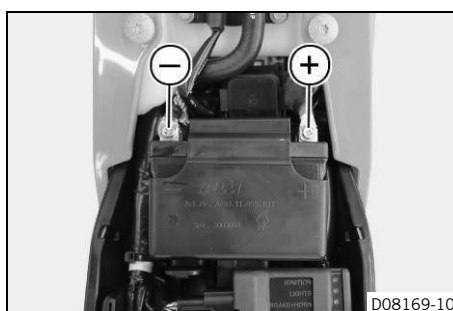
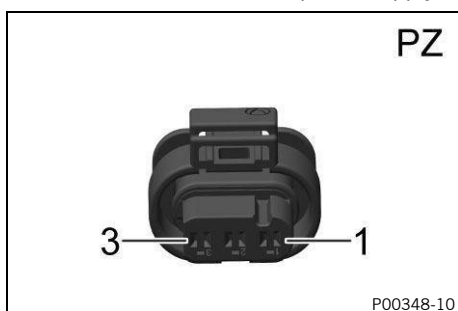

- + Diagnostic tool is connected and active
- + Engine control unit is connected  (p. 23)
- + Oil level sensor is disconnected  (p. 18)
- Oil level sensor – check the power supply.



V Voltage measurement points
Oil level sensor connector **PZ** Pin 1 – Measuring point **Ground (-)**



The value must not deviate from the battery voltage «**VBAT**» by more than 1 V.

i **Note**
For the measurement, the measuring points must be subjected to a 12 V/21 W bulb.

- » Specification does not match set value
 - Check Oil level sensor connector **PZ**  (p. 218) pin 1 and pin 3.
 - Check the wire from Oil level sensor connector **PZ**  (p. 218) pin 1 to the next node in the wiring harness.
 - Check wire from Vehicle system control unit connector **LL**  (p. 216) pin 3 to Oil level sensor connector **PZ**  (p. 218) pin 1.
- » If the specifications have been met:
 - Check the next possible cause
Oil level sensor – the signal wire is faulty

Oil level sensor – the signal wire is faulty

Condition



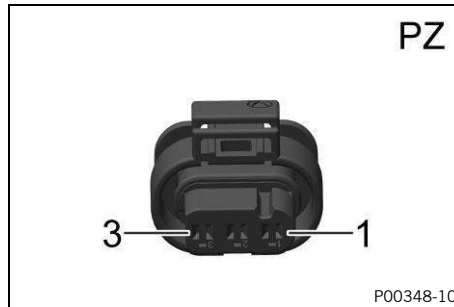
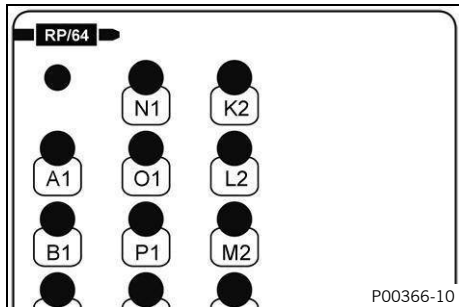

- + Diagnostic tool is disconnected
- + Engine control unit is disconnected  (p. 23)
- + The breakout box is connected to the engine control unit main wiring harness with adapter **00029095016**
- + Oil level sensor is disconnected  (p. 18)
- Oil level sensor – check signal wire.



Resistance measurement points



Bob box connector **RP** Pin **F1** – Oil level sensor connector **PZ** Pin **2**

Resistance	$\leq 0.6 \Omega$
------------	-------------------

- » Specification does not match set value
 - Check Engine control unit connector **RP**  (p. 218) pin **F1** and Oil level sensor connector **PZ**  (p. 218) pin **2**.
 - Check wire from Engine control unit connector **RP**  (p. 218) pin **F1** to Oil level sensor connector **PZ**  (p. 218) pin **2**.
- » If the specifications have been met:
 - Check the next possible cause
Oil level sensor – the ground wire is faulty

Oil level sensor – the ground wire is faulty

Condition

- + Diagnostic tool is connected and active
- + Engine control unit is connected  (p. 23)
- + Oil level sensor is disconnected  (p. 18)
- Oil level sensor – check the ground wire.

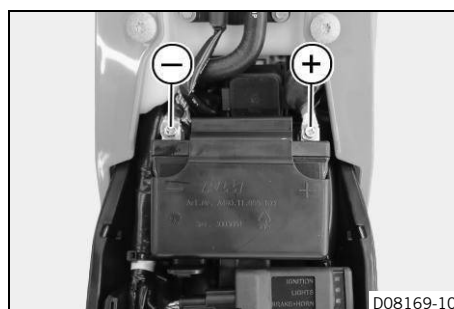
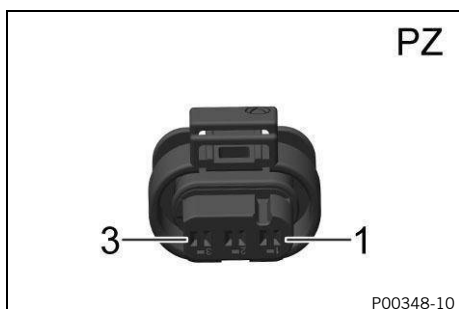

Voltage measurement points

Oil level sensor connector **PZ** Pin **3** – Measuring point **Plus (+)**

The value must not deviate from the battery voltage «VBAT» by more than 1 V.
--

3 Engine control trouble code

Note

For the measurement, the measuring points must be subjected to a 12 V/21 W bulb.

- » Specification does not match set value
 - Check Oil level sensor connector **PZ** (p. 218) pin **3**.
 - Check the wire from Oil level sensor connector **PZ** (p. 218) pin **3** to the next node in the wiring harness.
- » If the specifications have been met:
 - Check the next possible cause
 - Oil level sensor – the signal wire has a short circuit to ground (terminal 31)

Oil level sensor – the signal wire has a short circuit to ground (terminal 31)

Condition

- + Diagnostic tool is disconnected
- + Engine control unit is disconnected (p. 23)
- + The breakout box is connected to the engine control unit main wiring harness with adapter **00029095016**
- + Oil level sensor is disconnected (p. 18)
- Oil level sensor – check the signal wire for a short circuit to ground (terminal 31).

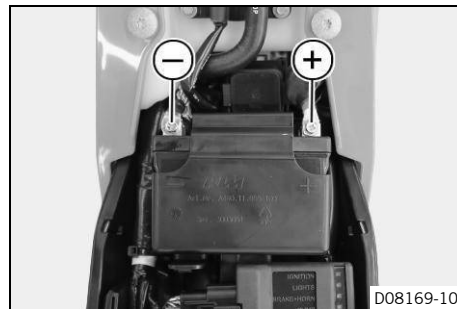
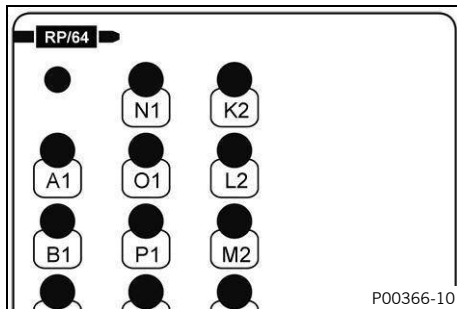

Resistance measurement points

Bob box connector **RP** Pin **F1** – Measuring point **Ground (-)**

Resistance	$\infty \Omega$
------------	-----------------

- » Specification does not match set value
 - Check wire from Engine control unit connector **RP** (p. 218) pin **F1** to Oil level sensor connector **PZ** (p. 218) pin **2** for a short circuit to ground (clamp 31).
- » If the specifications have been met:
 - Check the next possible cause
 - Oil level sensor – the signal wire has a short circuit to sensor ground

Oil level sensor – the signal wire has a short circuit to sensor ground

Condition

- + Diagnostic tool is disconnected
- + Engine control unit is disconnected (p. 23)
- + The breakout box is connected to the engine control unit main wiring harness with adapter **00029095016**
- + Motorcycle control unit is disconnected (p. 10)
- + Oil level sensor is disconnected (p. 18)
- Oil level sensor – check the signal wire for a short circuit to sensor ground.

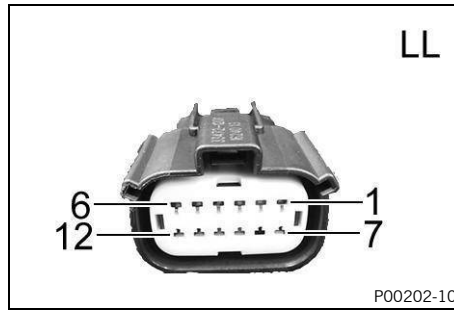
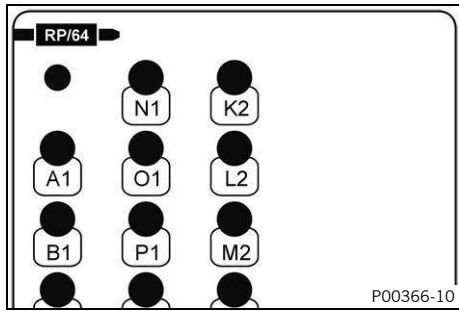

Resistance measurement points

Bob box connector **RP** Pin **F1** – Vehicle system control unit connector **LL** Pin **9**





Resistance	$\infty \Omega$
------------	-----------------

- » Specification does not match set value
 - Check wire from Engine control unit connector **RP** (p. 218) pin **F1** to Vehicle system control unit connector **LL** (p. 216) pin **9** for a short circuit to sensor ground.

Last action



- Contact customer service.

3 Engine control trouble code

Blink code for malfunction indicator light	 42: Malfunction indicator light flashes 4x long, 2x short
Display on diagnostic tool	P250D12 «Oil level sensor» «Short circuit to plus»
Error level condition	Oil level sensor – short circuit to plus
Possible cause	Oil level sensor – the signal wire has a short circuit to plus (terminal 30)  (p. 160)
	Oil level sensor – the signal wire has a short circuit to ignition plus (terminal 15)  (p. 160)
	Oil level sensor – the signal wire has a short circuit to the sensor power supply  (p. 161)
Last action	– Contact customer service.

Oil level sensor – the signal wire has a short circuit to plus (terminal 30)

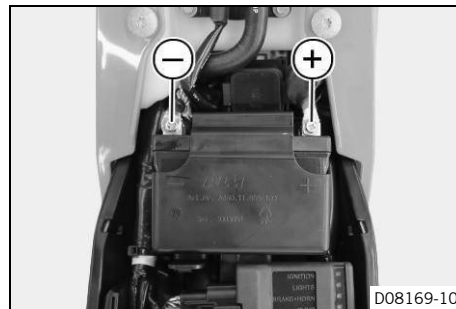
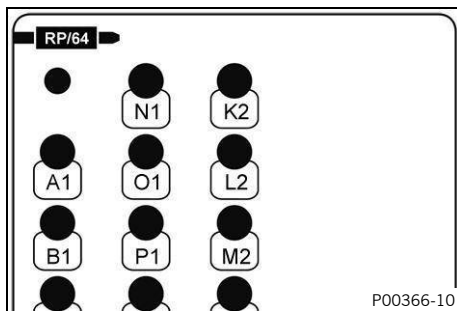

Condition

- + Diagnostic tool is disconnected
- + Engine control unit is disconnected  (p. 23)
- + The breakout box is connected to the engine control unit main wiring harness with adapter **00029095016**
- + Oil level sensor is disconnected  (p. 18)
- Oil level sensor – check the signal wire for a short circuit to plus (terminal 30).



V Voltage measurement points
Bob box connector **RP** Pin **F1** – Measuring point **Ground (-)**

Voltage	< 0.1 V
---------	---------

- » Specification does not match set value
 - Check wire from Engine control unit connector **RP**  (p. 218) pin **F1** to Oil level sensor connector **PZ**  (p. 218) pin **2** for a short circuit to plus (clamp 30).
- » If the specifications have been met:
 - Check the next possible cause
Oil level sensor – the signal wire has a short circuit to ignition plus (terminal 15)

Oil level sensor – the signal wire has a short circuit to ignition plus (terminal 15)

Condition

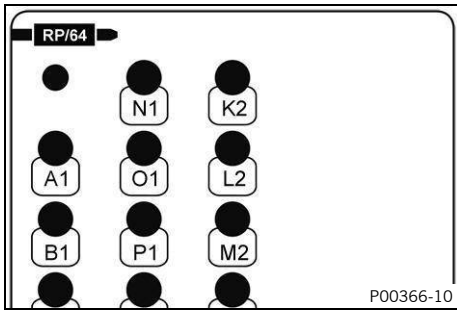

- + Diagnostic tool is disconnected
- + Engine control unit is disconnected  (p. 23)
- + The breakout box is connected to the engine control unit main wiring harness with adapter **00029095016**

- + Oil level sensor is disconnected  (p. 18)
- Oil level sensor – check if the signal wire has a short circuit to ignition plus (terminal 15).





 Resistance measurement points
 Bob box connector **RP** Pin **F1** – Bob box connector **RP** Pin **D4**

Resistance	$\infty \Omega$
------------	-----------------

- » Specification does not match set value
 - Check wire from Engine control unit connector **RP**  (p. 218) pin **F1** to Oil level sensor connector **PZ**  (p. 218) pin **2** for a short circuit to ignition plus (clamp 15).
- » If the specifications have been met:
 - Check the next possible cause
 Oil level sensor – the signal wire has a short circuit to the sensor power supply

Oil level sensor – the signal wire has a short circuit to the sensor power supply

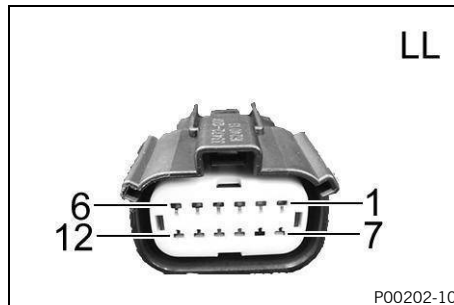
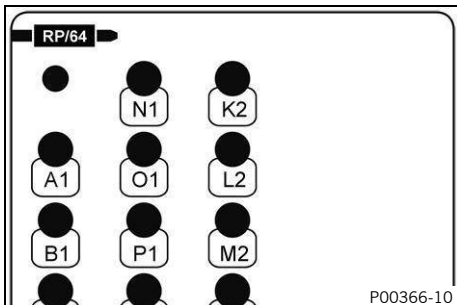

Condition

- + Diagnostic tool is disconnected
- + Engine control unit is disconnected  (p. 23)
- + The breakout box is connected to the engine control unit main wiring harness with adapter **00029095016**
- + Motorcycle control unit is disconnected  (p. 10)
- + Oil level sensor is disconnected  (p. 18)
- Oil level sensor – check the signal wire for a short circuit to the sensor power supply.



 Resistance measurement points
 Bob box connector **RP** Pin **F1** – Vehicle system control unit connector **LL** Pin **3**



Resistance	$\infty \Omega$
------------	-----------------

- » Specification does not match set value
 - Check wire from Engine control unit connector **RP**  (p. 218) pin **F1** to Vehicle system control unit connector **LL**  (p. 216) pin **3** for a short circuit to the sensor voltage supply.

Last action

- Contact customer service.

3 Engine control trouble code

Blink code for malfunction indicator light	 42: Malfunction indicator light flashes 4x long, 2x short
Display on diagnostic tool	P260C13 «Oil lamp» «Circuit fault»
Error level condition	Oil lamp – malfunction in the circuit
Possible cause	Oil lamp – the power supply is faulty  (p. 162)
	Oil lamp – control wire is faulty  (p. 162)
Last action	– Contact customer service.

Oil lamp – the power supply is faulty

Condition

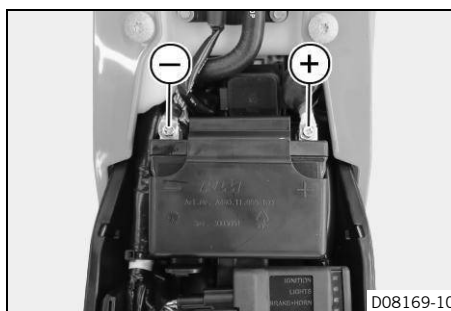
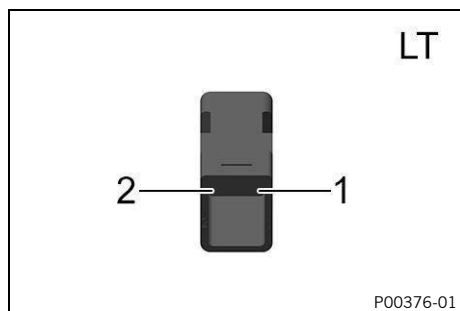

- + Diagnostic tool is connected and active
- + Engine control unit is connected  (p. 23)
- + Oil lamp is disconnected
- Oil lamp – check the power supply.



V Voltage measurement points
Oil lamp connector **LT** Pin **2** – Measuring point **Ground (-)**

The value must not deviate from the battery voltage «VBAT» by more than 1 V.

i **Note**
For the measurement, the measuring points must be subjected to a 12 V/21 W bulb.

- » Specification does not match set value
 - Check Oil lamp connector **LT**  (p. 217) pin **2**.
 - Check the wire from Oil lamp connector **LT**  (p. 217) pin **2** to the next node in the wiring harness.
- » If the specifications have been met:
 - Check the next possible cause
Oil lamp – control wire is faulty

Oil lamp – control wire is faulty

Condition

- + Diagnostic tool is disconnected
- + Engine control unit is disconnected  (p. 23)
- + The breakout box is connected to the engine control unit main wiring harness with adapter **00029095016**
- + Oil lamp is disconnected
- Oil lamp – check control wire.

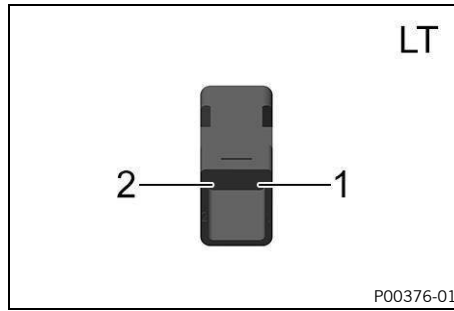
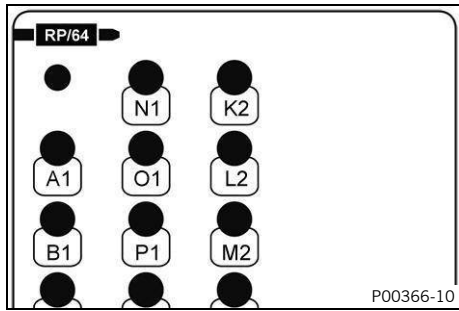

Ω Resistance measurement points
 Bob box connector **RP** Pin **L3** – Oil lamp connector **LT** Pin **1**





Resistance	≤ 0.6 Ω
------------	---------

- » Specification does not match set value
 - Check wire from Engine control unit connector **RP** (p. 218) pin **L3** to Oil lamp connector **LT** (p. 217) pin **1**.

Last action

- Contact customer service.

3 Engine control trouble code

Blink code for malfunction indicator light	 42: Malfunction indicator light flashes 4x long, 2x short
Display on diagnostic tool	P260D11 «Oil lamp» «Short circuit to ground»
Error level condition	Oil lamp – short circuit to ground
Possible cause	Oil lamp – the power supply is faulty  (p. 164)
	Oil lamp – the control wire has a short circuit to ground (terminal 31)  (p. 164)
	Oil lamp – the control wire has a short circuit to sensor ground  (p. 165)
Last action	– Contact customer service.

Oil lamp – the power supply is faulty

Condition

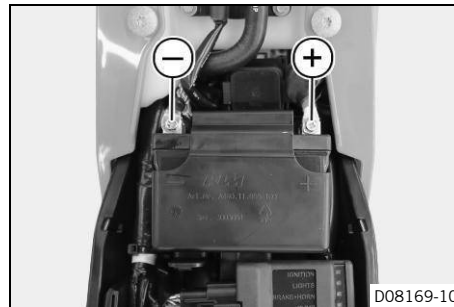
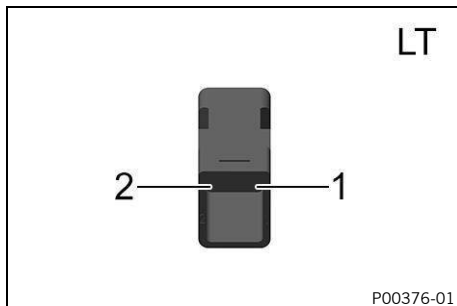

- + Diagnostic tool is connected and active
- + Engine control unit is connected  (p. 23)
- + Oil lamp is disconnected
- Oil lamp – check the power supply.



V Voltage measurement points
Oil lamp connector **LT** Pin **2** – Measuring point **Ground (-)**

The value must not deviate from the battery voltage «VBAT» by more than 1 V.

i **Note**
For the measurement, the measuring points must be subjected to a 12 V/21 W bulb.

- » Specification does not match set value
 - Check Oil lamp connector **LT**  (p. 217) pin **2**.
 - Check the wire from Oil lamp connector **LT**  (p. 217) pin **2** to the next node in the wiring harness.
- » If the specifications have been met:
 - Check the next possible cause
Oil lamp – the control wire has a short circuit to ground (terminal 31)

Oil lamp – the control wire has a short circuit to ground (terminal 31)

Condition

- + Diagnostic tool is disconnected
- + Engine control unit is disconnected  (p. 23)
- + The breakout box is connected to the engine control unit main wiring harness with adapter **00029095016**
- + Oil lamp is disconnected
- Oil lamp – check the control wire for a short circuit to ground (terminal 31).

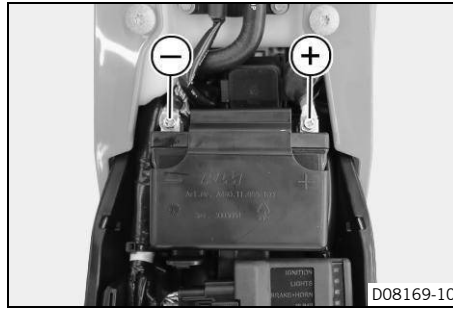
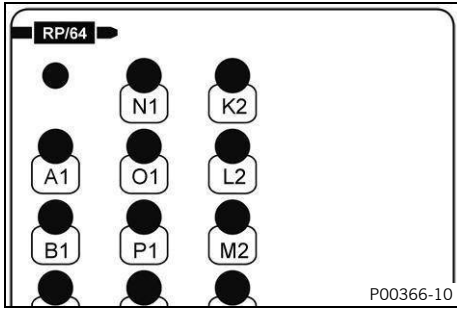

Ω Resistance measurement points
Bob box connector **RP** Pin **L3** – Measuring point **Ground (-)**

Resistance	$\infty \Omega$
------------	-----------------

- » Specification does not match set value
 - Check wire from Engine control unit connector **RP** (p. 218) pin **L3** to Oil lamp connector **LT** (p. 217) pin **1** for a short circuit to ground (clamp 31).
- » If the specifications have been met:
 - Check the next possible cause
Oil lamp – the control wire has a short circuit to sensor ground

Oil lamp – the control wire has a short circuit to sensor ground

Condition

- + Diagnostic tool is disconnected
- + Engine control unit is disconnected (p. 23)
- + The breakout box is connected to the engine control unit main wiring harness with adapter **00029095016**
- + Oil lamp is disconnected
- Oil lamp – check the control wire for a short circuit to sensor ground.

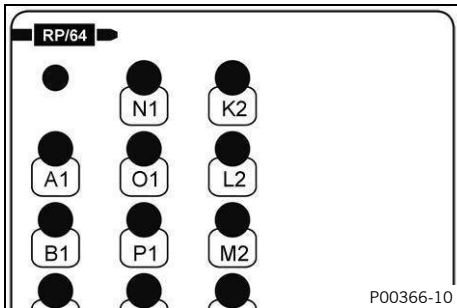

Ω Resistance measurement points
Bob box connector **RP** Pin **L3** – Bob box connector **RP** Pin **E2**





Resistance	$\infty \Omega$
------------	-----------------

- » Specification does not match set value
 - Check wire from Engine control unit connector **RP** (p. 218) pin **L3** to Oil lamp connector **LT** (p. 217) pin **1** for a short circuit to sensor ground.

Last action

- Contact customer service.

3 Engine control trouble code

Blink code for malfunction indicator light	 42: Malfunction indicator light flashes 4x long, 2x short
Display on diagnostic tool	P260E12 «Oil lamp» «Short circuit to plus»
Error level condition	Oil lamp – short circuit to plus
Possible cause	Oil lamp – the control wire has a short circuit to plus (terminal 30)  (p. 166)
	Oil lamp – the control wire has a short circuit to ignition plus (terminal 15)  (p. 166)
	Oil lamp – control wire has a short circuit to the sensor power supply  (p. 167)
Last action	– Contact customer service.

Oil lamp – the control wire has a short circuit to plus (terminal 30)

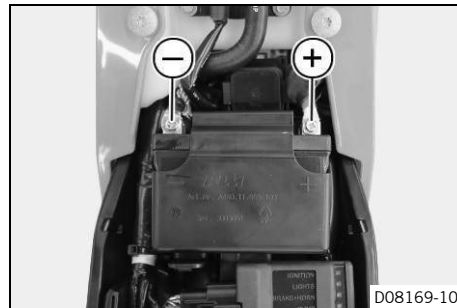
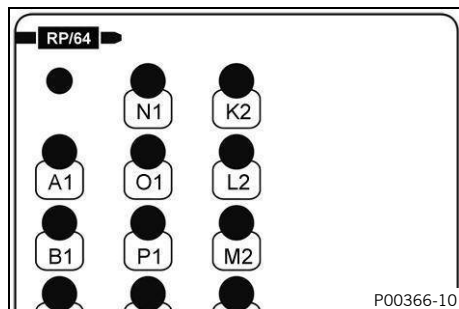

Condition

- + Diagnostic tool is disconnected
- + Engine control unit is disconnected  (p. 23)
- + The breakout box is connected to the engine control unit main wiring harness with adapter **00029095016**
- + Oil lamp is disconnected
- Oil lamp – check the control wire for a short circuit to plus (terminal 30).



V Voltage measurement points
Bob box connector **RP** Pin **L3** – Measuring point **Ground (-)**

Voltage	$\leq 0.1 \text{ V}$
---------	----------------------

- » Specification does not match set value
 - Check wire from Engine control unit connector **RP**  (p. 218) pin **L3** to Oil lamp connector **LT**  (p. 217) pin **1** for a short circuit to plus (clamp 30).
- » If the specifications have been met:
 - Check the next possible cause
Oil lamp – the control wire has a short circuit to ignition plus (terminal 15)

Oil lamp – the control wire has a short circuit to ignition plus (terminal 15)

Condition

- + Diagnostic tool is disconnected
- + Engine control unit is disconnected  (p. 23)
- + The breakout box is connected to the engine control unit main wiring harness with adapter **00029095016**
- + Oil lamp is disconnected
- Oil lamp – check the control wire for a short circuit to ignition plus (terminal 15).

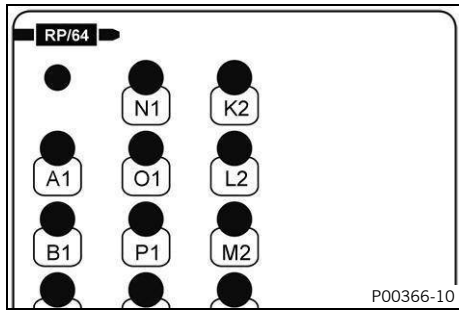

Resistance measurement points
Bob box connector **RP** Pin **L3** – Bob box connector **RP** Pin **D4**

Resistance	$\infty \Omega$
------------	-----------------

- » Specification does not match set value
 - Check wire from Engine control unit connector **RP** (p. 218) pin **L3** to Oil lamp connector **LT** (p. 217) pin **1** for a short circuit to ignition plus (clamp 15).
- » If the specifications have been met:
 - Check the next possible cause
Oil lamp – control wire has a short circuit to the sensor power supply

Oil lamp – control wire has a short circuit to the sensor power supply

Condition

- + Diagnostic tool is disconnected
- + Engine control unit is disconnected (p. 23)
- + The breakout box is connected to the engine control unit main wiring harness with adapter **00029095016**
- + Oil lamp is disconnected
- Oil lamp – check the control wire for a short circuit to the sensor power supply.

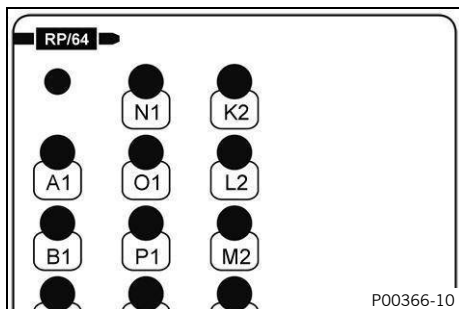

Resistance measurement points
Bob box connector **RP** Pin **L3** – Bob box connector **RP** Pin **D3**

Resistance	$\infty \Omega$
------------	-----------------



- » Specification does not match set value
 - Check wire from Engine control unit connector **RP** (p. 218) pin **L3** to Oil lamp connector **LT** (p. 217) pin **1** for a short circuit to the sensor voltage supply.

Last action

- Contact customer service.

4 Trouble code, Connectivity Unit

4.1 Trouble code, Connectivity Unit

Connectivity Unit blink code	 Indicator light flashes red 1x
Display on diagnostic tool	B10F149 «Connectivity Unit» «Accelerator sensor malfunction»
Error level condition	Accelerator sensor malfunction
Function check	Resetting the Connectivity Unit  (p. 168)
Last action	– Contact customer service.

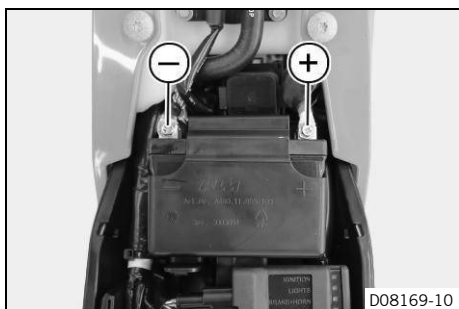

Resetting the Connectivity Unit



- Disconnect the negative terminal of the 12-V battery.
- Wait for 10 minutes.
- Connect the negative terminal of the 12-V battery.
- Clear fault memory with diagnostic tool.
- Disconnect the diagnostics tool for 30 seconds.
- Read out the fault memory using the diagnostics tool.
 - » If the error persists:
 - Change Connectivity Unit.

Last action

- Contact customer service.

Connectivity Unit blink code	 Indicator light flashes red 1x
Display on diagnostic tool	B10F349 «Connectivity Unit» «GPS sensor malfunction»
Error level condition	GPS sensor malfunction
Function check	Resetting the Connectivity Unit  (p. 169)
Last action	– Contact customer service.

Resetting the Connectivity Unit

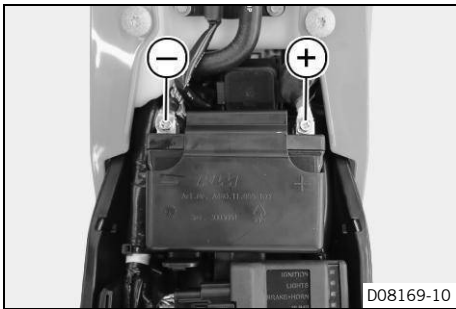



- Disconnect the negative terminal of the 12-V battery.
- Wait for 10 minutes.
- Connect the negative terminal of the 12-V battery.
- Clear fault memory with diagnostic tool.
- Disconnect the diagnostics tool for 30 seconds.
- Read out the fault memory using the diagnostics tool.
 - » If the error persists:
 - Change Connectivity Unit.

Last action

- Contact customer service.

4 Trouble code, Connectivity Unit

Connectivity Unit blink code	 Indicator light flashes red 4x
Display on diagnostic tool	B10F449 «Connectivity Unit» «Bluetooth malfunction»
Error level condition	Bluetooth malfunction
Function check	Resetting the Connectivity Unit  (p. 170)
Last action	– Contact customer service.

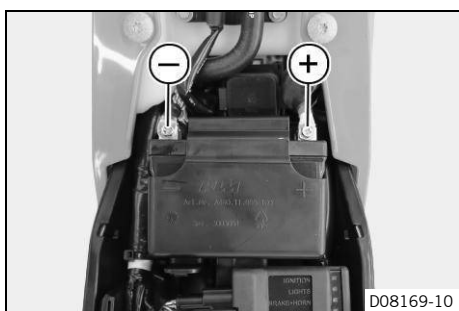

Resetting the Connectivity Unit



- Disconnect the negative terminal of the 12-V battery.
- Wait for 10 minutes.
- Connect the negative terminal of the 12-V battery.
- Clear fault memory with diagnostic tool.
- Disconnect the diagnostics tool for 30 seconds.
- Read out the fault memory using the diagnostics tool.
 - » If the error persists:
 - Change Connectivity Unit.

Last action

- Contact customer service.

Connectivity Unit blink code	 Indicator light flashes red 3x
Display on diagnostic tool	B10F549 «Connectivity Unit» «WLAN malfunction»
Error level condition	WLAN malfunction
Function check	Resetting the Connectivity Unit  (p. 171)
Last action	– Contact customer service.

Resetting the Connectivity Unit

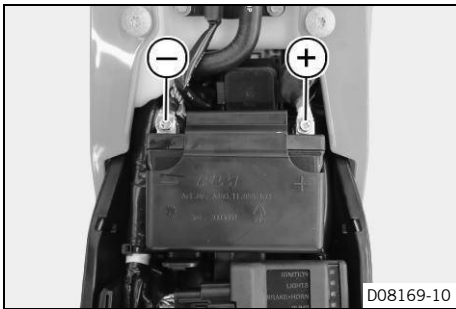



- Disconnect the negative terminal of the 12-V battery.
- Wait for 10 minutes.
- Connect the negative terminal of the 12-V battery.
- Clear fault memory with diagnostic tool.
- Disconnect the diagnostics tool for 30 seconds.
- Read out the fault memory using the diagnostics tool.
 - » If the error persists:
 - Change Connectivity Unit.

Last action

- Contact customer service.

4 Trouble code, Connectivity Unit

Connectivity Unit blink code	 Indicator light flashes red 1x
Display on diagnostic tool	B10F649 «Connectivity Unit» «LED malfunction»
Error level condition	LED malfunction
Function check	Resetting the Connectivity Unit  (p. 172)
Last action	– Contact customer service.

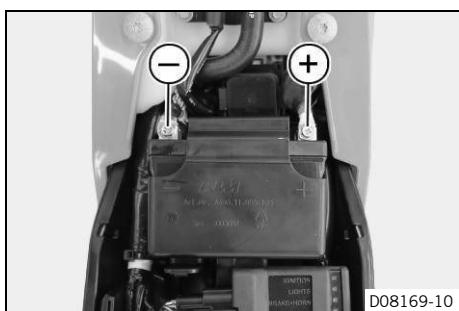

Resetting the Connectivity Unit



- Disconnect the negative terminal of the 12-V battery.
- Wait for 10 minutes.
- Connect the negative terminal of the 12-V battery.
- Clear fault memory with diagnostic tool.
- Disconnect the diagnostics tool for 30 seconds.
- Read out the fault memory using the diagnostics tool.
 - » If the error persists:
 - Change Connectivity Unit.

Last action

- Contact customer service.

Connectivity Unit blink code	 Indicator light flashes red 1x
Display on diagnostic tool	B10F701 «Connectivity Unit» «Button malfunction»
Error level condition	Button pressed for more than 60 seconds
Function check	Resetting the Connectivity Unit  (p. 173)
Last action	– Contact customer service.

Resetting the Connectivity Unit

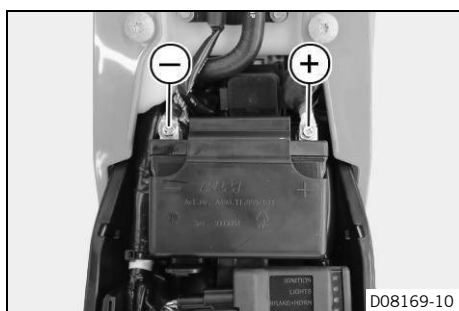



- Disconnect the negative terminal of the 12-V battery.
- Wait for 10 minutes.
- Connect the negative terminal of the 12-V battery.
- Clear fault memory with diagnostic tool.
- Disconnect the diagnostics tool for 30 seconds.
- Read out the fault memory using the diagnostics tool.
 - » If the error persists:
 - Change Connectivity Unit.

Last action

- Contact customer service.

4 Trouble code, Connectivity Unit

Connectivity Unit blink code	 Indicator light flashes red 1x
Display on diagnostic tool	B10F842 «Connectivity Unit» «Memory faulty»
Error level condition	Memory faulty
Function check	Resetting the Connectivity Unit  (p. 174)
Last action	– Contact customer service.



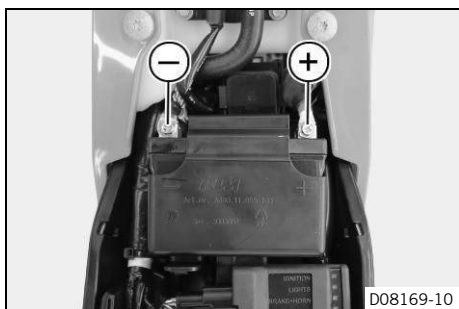

Resetting the Connectivity Unit



- Disconnect the negative terminal of the 12-V battery.
- Wait for 10 minutes.
- Connect the negative terminal of the 12-V battery.
- Clear fault memory with diagnostic tool.
- Disconnect the diagnostics tool for 30 seconds.
- Read out the fault memory using the diagnostics tool.
 - » If the error persists:
 - Change Connectivity Unit.



Last action

- Contact customer service.

Connectivity Unit blink code	 Indicator light flashes red 1x
Display on diagnostic tool	B10FB13 «Control wire, power relay» «Open circuit»
Error level condition	Control wire, power relay – circuit interrupted
Possible cause	Power relay – the control wire is faulty  (p. 175)
	Power relay – the control wire has a short circuit to plus (terminal 30)  (p. 175)
	Power relay – the control wire has a short circuit to ground (terminal 31)  (p. 176)
Last action	– Contact customer service.

Power relay – the control wire is faulty

Condition

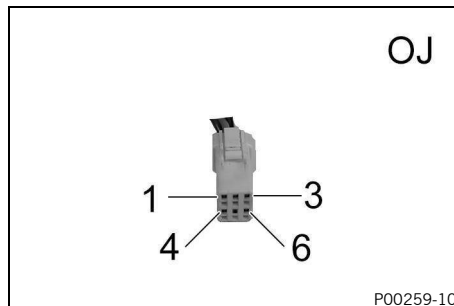
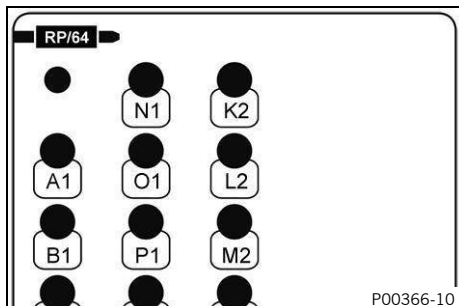

- + Diagnostic tool is disconnected
- + Engine control unit is disconnected  (p. 23)
- + The breakout box is connected to the engine control unit main wiring harness with adapter **00029095016**
- + Motorcycle control unit is disconnected  (p. 10)
- + Connectivity Unit is disconnected  (p. 24)
- + Regulator rectifier is disconnected
- Power relay – check the control wire.



Resistance measurement points



Bob box connector **RP** Pin **B4** – Connectivity Unit connector **OJ** Pin **5**

Resistance	≤ 0.6 Ω
------------	---------

- » Specification does not match set value
 - Check wire from Engine control unit connector **RP**  (p. 218) pin **B4** to Connectivity Unit connector **OJ**  (p. 217) pin **5**.
- » If the specifications have been met:
 - Check the next possible cause
Power relay – the control wire has a short circuit to plus (terminal 30)

Power relay – the control wire has a short circuit to plus (terminal 30)

Condition

- + Diagnostic tool is disconnected
- + Engine control unit is disconnected  (p. 23)
- + Motorcycle control unit is disconnected  (p. 10)

4 Trouble code, Connectivity Unit

- + Connectivity Unit is disconnected  (p. 24)
- + Regulator rectifier is disconnected
- Power relay – check the control wire for a short circuit to plus (terminal 30).

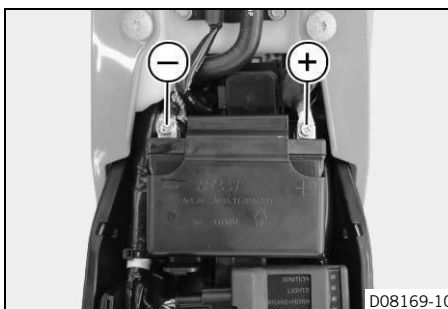
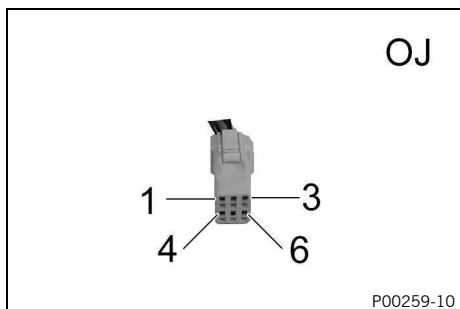



V Voltage measurement points
Connectivity Unit connector **OJ** Pin **5** – Measuring point **Ground (-)**

Voltage	< 0.1 V
---------	---------

- » Specification does not match set value
 - Check wire from Connectivity Unit connector **OJ**  (p. 217) pin **5** against the wiring diagram for a short circuit to plus (terminal 30).
- » If the specifications have been met:
 - Check the next possible cause
Power relay – the control wire has a short circuit to ground (terminal 31)

Power relay – the control wire has a short circuit to ground (terminal 31)

Condition

- + Diagnostic tool is disconnected
- + Engine control unit is disconnected  (p. 23)
- + Motorcycle control unit is disconnected  (p. 10)
- + Connectivity Unit is disconnected  (p. 24)
- + Regulator rectifier is disconnected
- Power relay – check the control wire for a short circuit to ground (terminal 31).

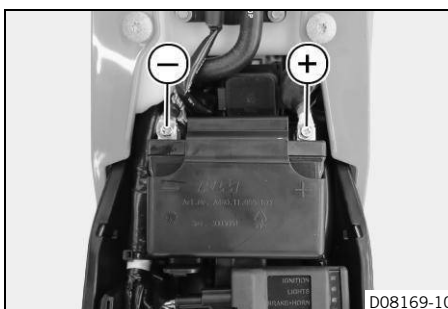
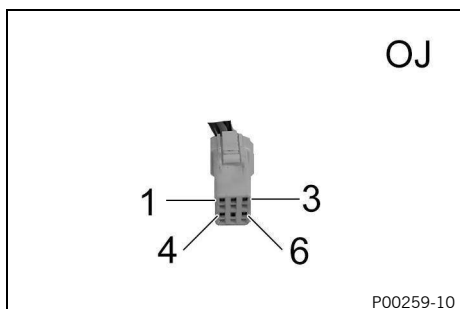



Ω Resistance measurement points
Connectivity Unit connector **OJ** Pin **5** – Measuring point **Ground (-)**

Resistance	$\infty \Omega$
------------	-----------------

- » Specification does not match set value
 - Check wire from Connectivity Unit connector **OJ**  (p. 217) pin **5** against the wiring diagram for a short circuit to ground (clamp 31).

Last action

- Contact customer service.

Connectivity Unit blink code	 Indicator light flashes red 1x
Display on diagnostic tool	B10FC17 «Connectivity Unit» «Power supply exceeded»
Error level condition	Voltage: ≥ 16 V
Function check	Checking the charging voltage  (p. 177)
Last action	– Contact customer service.

Checking the charging voltage

Condition

- + The 12 V battery must be fully functional and completely charged.

Preparatory work

- Remove the seat.

Control process

- Carry out the starting procedure.
- Take the measurement.

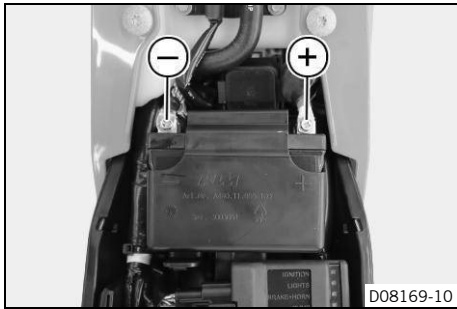

V Voltage measurement points
Measuring point **Plus (+)** – Measuring point **Ground (-)**

Charging voltage	13.5 V ... 15.0 V
------------------	-------------------

- » If the displayed value is less than the specified value:
 - Check the plug-in connections from the alternator to the regulator rectifier.
 - Check the plug-in connections from the regulator rectifier to the wiring harness.
 - Check the stator winding of the alternator.
- » If the displayed value is greater than the specified value:
 - Change regulator rectifier.



Reworking

- Mount the seat.

Last action

- Contact customer service.

4 Trouble code, Connectivity Unit

Connectivity Unit blink code	 Indicator light flashes red 1x
Display on diagnostic tool	B10FD16 «Connectivity Unit» «Power supply below specification»
Error level condition	Voltage: ≤ 8 V
Possible cause	Connectivity Unit – power supply 1 is faulty  (p. 178)
	Connectivity Unit – voltage supply 2 is faulty  (p. 178)
Last action	– Contact customer service.

Connectivity Unit – power supply 1 is faulty

Condition

- + Diagnostic tool is connected and active
- + Connectivity Unit is disconnected  (p. 24)
- Connectivity Unit – check power supply 1.

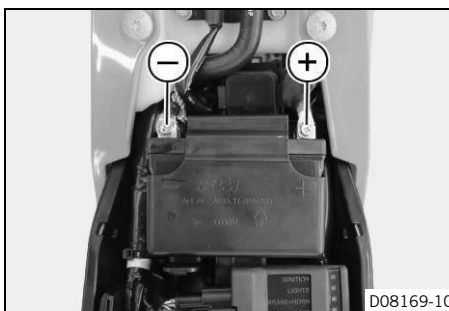
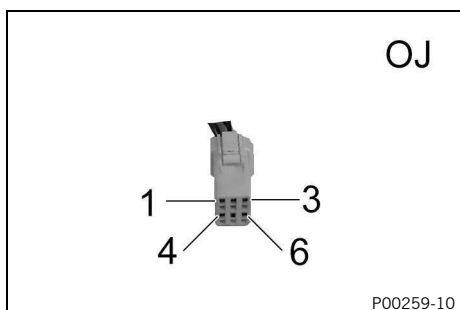



V Voltage measurement points
Connectivity Unit connector **OJ** Pin **1** – Measuring point **Ground (-)**

The value must not deviate from the battery voltage «VBAT» by more than 1 V.

i **Note**

For the measurement, the measuring points must be subjected to a 12 V/21 W bulb.

- » Specification does not match set value
 - Check Connectivity Unit connector **OJ**  (p. 217) pin **1**.
 - Check wire from Connectivity Unit connector **OJ**  (p. 217) pin **1** to the next node in the wiring harness.
- » If the specifications have been met:
 - Check the next possible cause
Connectivity Unit – voltage supply 2 is faulty

Connectivity Unit – voltage supply 2 is faulty

Condition

- + Diagnostic tool is connected and active
- + Connectivity Unit is disconnected  (p. 24)
- Connectivity Unit – check power supply 2.

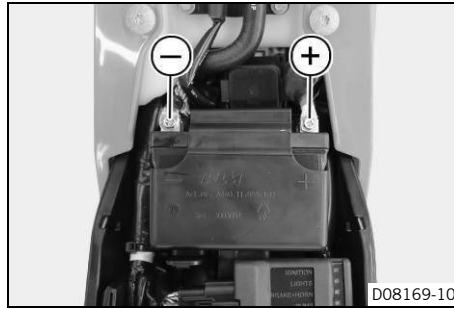
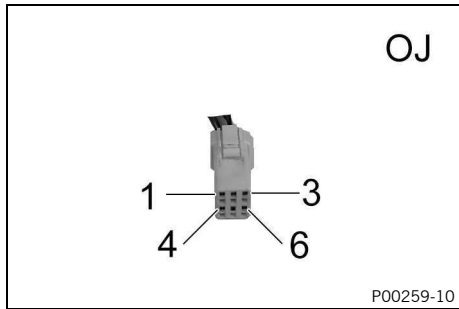

Voltage measurement points

Connectivity Unit connector **OJ** Pin **6** – Measuring point **Ground (-)**

The value must not deviate from the battery voltage «**VBAT**» by more than 1 V.



Note



For the measurement, the measuring points must be subjected to a 12 V/21 W bulb.

- » Specification does not match set value
 - Check Connectivity Unit connector **OJ** (p. 217) pin **6**.
 - Check wire from Connectivity Unit connector **OJ** (p. 217) pin **6** to the next node in the wiring harness.

Last action

- Contact customer service.

4 Trouble code, Connectivity Unit

Connectivity Unit blink code	 Indicator light flashes red 1x
Display on diagnostic tool	B10FE4B «Connectivity Unit» «Temperature too high»
Error level condition	Temperature: $\geq 70\text{ °C}$ ($\geq 158.0\text{ °F}$)
Function check	Checking the Connectivity Unit temperature  (p. 180)
Last action	– Contact customer service.

Checking the Connectivity Unit temperature

Condition



- + Diagnostic tool is connected and active
- Check the plausibility of the Connectivity Unit temperature being exceeded.

Result is plausible.

- » If the specified value is reached:
 - Clear fault memory with diagnostic tool.
 - Read out the fault memory using the diagnostics tool.
- » If the specification is not reached:
 - Change Connectivity Unit.

Last action

- Contact customer service.

Connectivity Unit blink code	 Indicator light flashes red 1x
Display on diagnostic tool	B10FF00 «Connectivity Unit» «Temperature too low»
Error level condition	Temperature: ≤ -10 °C (≤ 14.0 °F)
Function check	Checking the Connectivity Unit temperature  (p. 181)
Last action	– Contact customer service.

Checking the Connectivity Unit temperature

Condition

- + Diagnostic tool is connected and active
- Check the plausibility of the Connectivity Unit temperature being exceeded.

Result is plausible.



- » If the specified value is reached:
 - Clear fault memory with diagnostic tool.
 - Read out the fault memory using the diagnostics tool.
- » If the specification is not reached:
 - Change Connectivity Unit.



Last action

- Contact customer service.

4 Trouble code, Connectivity Unit

Connectivity Unit blink code	 Indicator light flashes red 1x
Display on diagnostic tool	B110092 «Connectivity Unit» «CPU overload»
Error level condition	CPU overload
Function check	Resetting the Connectivity Unit  (p. 182)
Last action	– Contact customer service.

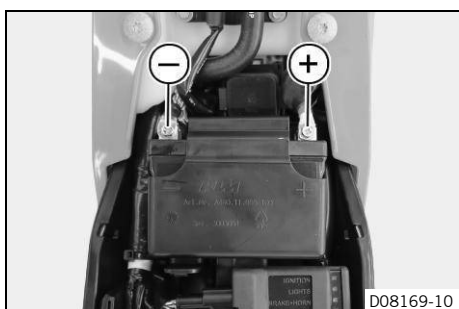

Resetting the Connectivity Unit



- Disconnect the negative terminal of the 12-V battery.
- Wait for 10 minutes.
- Connect the negative terminal of the 12-V battery.
- Clear fault memory with diagnostic tool.
- Disconnect the diagnostics tool for 30 seconds.
- Read out the fault memory using the diagnostics tool.
 - » If the error persists:
 - Change Connectivity Unit.

Last action

- Contact customer service.

Connectivity Unit blink code	 Indicator light flashes red 1x
Display on diagnostic tool	B110192 «Connectivity Unit» «RAM overload»
Error level condition	RAM overload
Function check	Resetting the Connectivity Unit  (p. 183)
Last action	– Contact customer service.

Resetting the Connectivity Unit

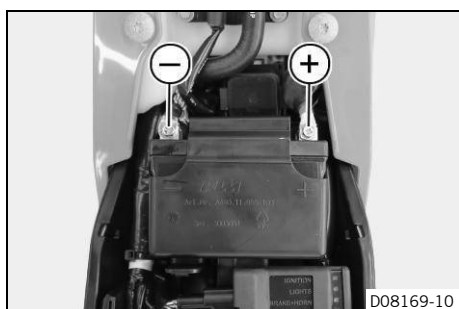



- Disconnect the negative terminal of the 12-V battery.
- Wait for 10 minutes.
- Connect the negative terminal of the 12-V battery.
- Clear fault memory with diagnostic tool.
- Disconnect the diagnostics tool for 30 seconds.
- Read out the fault memory using the diagnostics tool.
 - » If the error persists:
 - Change Connectivity Unit.

Last action

- Contact customer service.

4 Trouble code, Connectivity Unit

Connectivity Unit blink code	 Indicator light flashes red 7x
Display on diagnostic tool	B110292 «Connectivity Unit» «ROM overload»
Error level condition	ROM overload
Function check	Resetting the Connectivity Unit  (p. 184)
Last action	– Contact customer service.

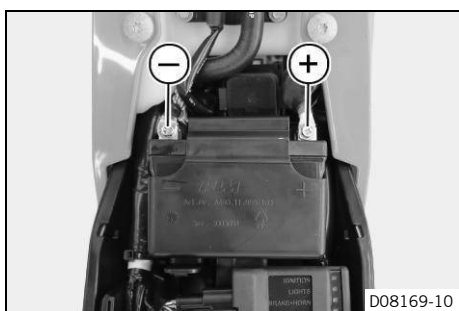

Resetting the Connectivity Unit



- Disconnect the negative terminal of the 12-V battery.
- Wait for 10 minutes.
- Connect the negative terminal of the 12-V battery.
- Clear fault memory with diagnostic tool.
- Disconnect the diagnostics tool for 30 seconds.
- Read out the fault memory using the diagnostics tool.
 - » If the error persists:
 - Change Connectivity Unit.

Last action

- Contact customer service.

Connectivity Unit blink code	 Indicator light flashes red 6x
Display on diagnostic tool	B110300 «Connectivity Unit» «VIN deviation»
Error level condition	VIN does not match
Function check	Reset the Connectivity Unit to factory settings  (p. 185)
Last action	– Contact customer service.

Reset the Connectivity Unit to factory settings

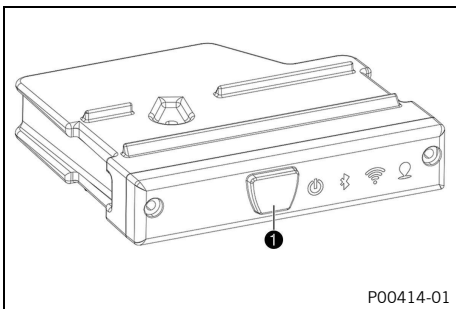



- Press and hold button ❶ (6 s to 12 s) – the Connectivity Unit is prepared for reset to factory settings.
- Press and hold button ❶ (12 s to 18 s) – the Connectivity Unit is reset to factory settings.
- Reconnect Connectivity Unit with smartphone app.
- Clear fault memory with diagnostic tool.
- Disconnect the diagnostics tool for 30 seconds.
- Read out the fault memory using the diagnostics tool.
 - » If the error persists:
 - Change Connectivity Unit.



Last action

- Contact customer service.

4 Trouble code, Connectivity Unit

Connectivity Unit blink code	 Indicator light flashes red 8x
Display on diagnostic tool	B110600 «Connectivity Unit» «Reset while lock is active»
Error level condition	Reset attempted while lock active
Function check	Resetting the Connectivity Unit  (p. 186)
Last action	– Contact customer service.

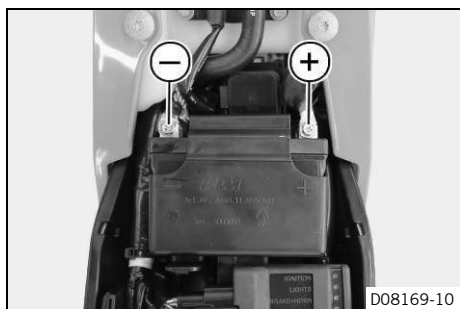

Resetting the Connectivity Unit



- Disconnect the negative terminal of the 12-V battery.
- Wait for 10 minutes.
- Connect the negative terminal of the 12-V battery.
- Clear fault memory with diagnostic tool.
- Disconnect the diagnostics tool for 30 seconds.
- Read out the fault memory using the diagnostics tool.
 - » If the error persists:
 - Change Connectivity Unit.

Last action

- Contact customer service.

Connectivity Unit blink code	 Indicator light flashes red 1x
Display on diagnostic tool	B110744 «Connectivity Unit» «Memory error»
Error level condition	Flash storage formatted due to storage damage
Function check	Resetting the Connectivity Unit  (p. 187)
Last action	– Contact customer service.

Resetting the Connectivity Unit

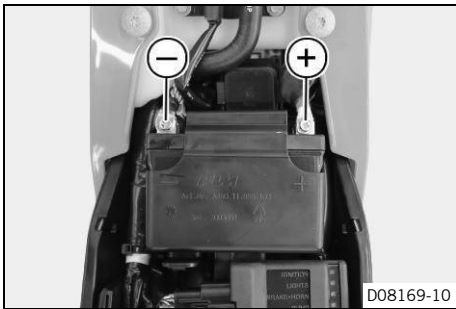



- Disconnect the negative terminal of the 12-V battery.
- Wait for 10 minutes.
- Connect the negative terminal of the 12-V battery.
- Clear fault memory with diagnostic tool.
- Disconnect the diagnostics tool for 30 seconds.
- Read out the fault memory using the diagnostics tool.
 - » If the error persists:
 - Change Connectivity Unit.

Last action

- Contact customer service.

4 Trouble code, Connectivity Unit

Connectivity Unit blink code	 Indicator light flashes red 2x
Display on diagnostic tool	U100288 «Connectivity Unit» «CAN bus communication faulty»
Error level condition	CAN bus communication faulty
Possible cause	Check the CAN bus total resistance  (p. 188)
Last action	– Contact customer service.

Check the CAN bus total resistance

Condition

- + Diagnostic tool is disconnected
- + Connectivity Unit is disconnected  (p. 24)
- CAN bus total resistance – check the resistance.

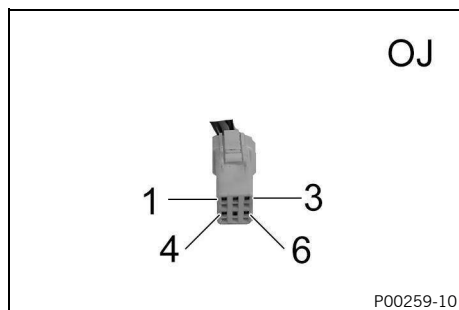



Resistance measurement points
Connectivity Unit connector **OJ** Pin **2** – Connectivity Unit connector **OJ** Pin **3**

CAN bus total resistance	
Resistance on connected engine control unit and CAN bus terminating resistor: 20 °C (68.0 °F)	54 Ω ... 66 Ω

- » Specification does not match set value
 - Check the CAN bus wires.

Last action

- Contact customer service.

Connectivity Unit blink code	 Indicator light flashes red 2x
Display on diagnostic tool	U100408 «Connectivity Unit» «Faulty CAN bus communication with engine control unit»
Error level condition	Faulty CAN bus communication with engine control unit
Possible cause	Check the CAN bus total resistance  (p. 189)
Last action	– Contact customer service.

Check the CAN bus total resistance

Condition

- + Diagnostic tool is disconnected
- + Connectivity Unit is disconnected  (p. 24)
- CAN bus total resistance – check the resistance.

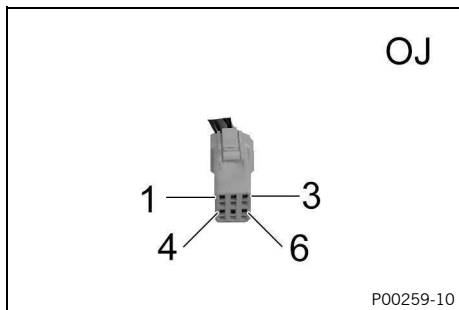

Resistance measurement points

Connectivity Unit connector **OJ** Pin **2** – Connectivity Unit connector **OJ** Pin **3**



CAN bus total resistance	
Resistance on connected engine control unit and CAN bus terminating resistor: 20 °C (68.0 °F)	54 Ω ... 66 Ω

- » Specification does not match set value
 - Check the CAN bus wires.

Last action

- Contact customer service.

4 Trouble code, Connectivity Unit

Connectivity Unit blink code	 Indicator light flashes red 1x
Display on diagnostic tool	U101201 «Connectivity Unit» «CAN bus hardware communication faulty»
Error level condition	CAN bus driver faulty
Function check	Resetting the Connectivity Unit  (p. 190)
Last action	– Contact customer service.

Resetting the Connectivity Unit

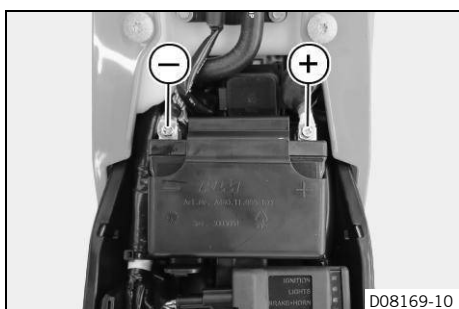

- Disconnect the negative terminal of the 12-V battery.
- Wait for 10 minutes.
- Connect the negative terminal of the 12-V battery.
- Clear fault memory with diagnostic tool.
- Disconnect the diagnostics tool for 30 seconds.
- Read out the fault memory using the diagnostics tool.
 - » If the error persists:
 - Change Connectivity Unit.

Last action

- Contact customer service.

5.1 Injector 1 function

5.1.1 Functional description

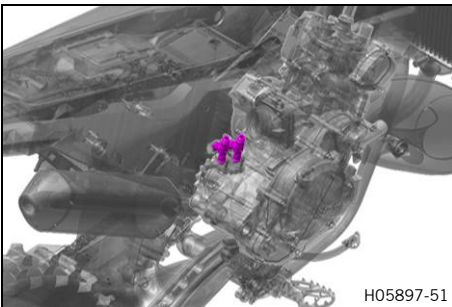

NOTE

Material damage Insufficient fuel lubricant has a negative effect on the service life of the injection valve.

- Perform the actuator test only when the throttle valve body is connected to the fuel line.

- Injector 1 is supplied with power via clamp 15. After actuator test (**Einspritzventil 1**) is started, the engine control unit switches the injection valve ground signal on/off. An acoustic confirmation signal confirms correct operation.



Note

The test ends automatically after ten seconds.

5.2 Injection valve 2 function

5.2.1 Functional description

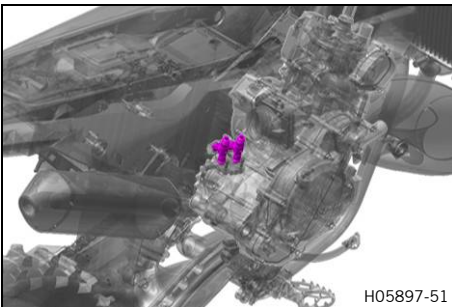

NOTE

Material damage Insufficient fuel lubricant has a negative effect on the service life of the injection valve.

- Perform the actuator test only when the throttle valve body is connected to the fuel line.

- Injector 2 is supplied with power via clamp 15. After actuator test (**Einspritzventil 2**) is started, the engine control unit switches the injection valve ground signal on/off. An acoustic confirmation signal confirms correct operation.



Note

The test ends automatically after ten seconds.

5.3 Function of ignition coil

5.3.1 Functional description

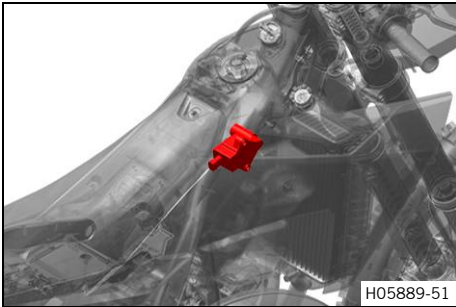

WARNING

Risk of injury The ignition system operates at high voltage.

- Do not touch any affected metal parts or the ends of the connection cables during or immediately after the measurement.

- After the actuator test starts, the engine control unit triggers a thyristor in the control unit. In this way, the capacitor can be abruptly discharged. An audible signal or a test spark plug is used to check the function of the ignition.



Note

The test is interrupted by pressing the «Quit» button.

5.4 Fuel pump operation

5.4.1 Functional description

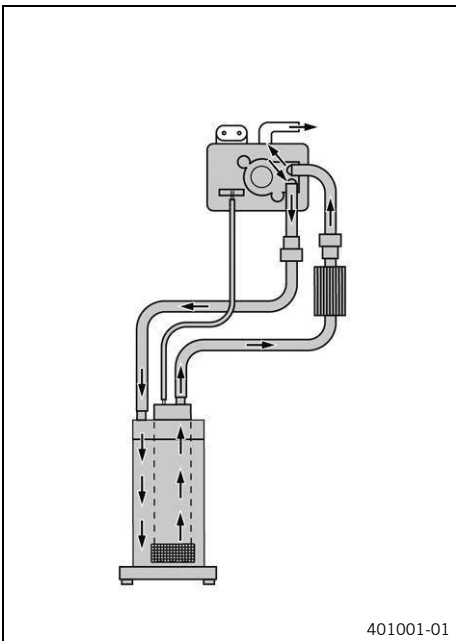

- The engine control unit activates the fuel pump.



Note

The test can be interrupted by pressing the «Quit» button.

5.5 Radiator fan function

5.5.1 Functional description

- The engine control unit activates the radiator fan.

Note

The actuator test must be activated with the engine running.
The radiator fan is actuated as soon as the engine is switched off.
When the lighting system switches off, the actuator test is ended.

Components:

A10	Vehicle system control unit	M10	Starter motor
A11	Engine control unit	M13	Fuel pump
G10	12 V battery	M14	Radiator fan (if installed)
G20	Alternator	S34	Combination switch, right
K10	Starter relay with main fuse	T20	Voltage regulator

Cable colors:

bl	black	or	Orange
br	brown	pk	Pink
bu	blue	pu	Violet
gn	green	rd	Red
gr	Gray	wh	White
lbu	Light blue	ye	Yellow

6 Wiring diagram

6.2 Page 2 (All EU models)

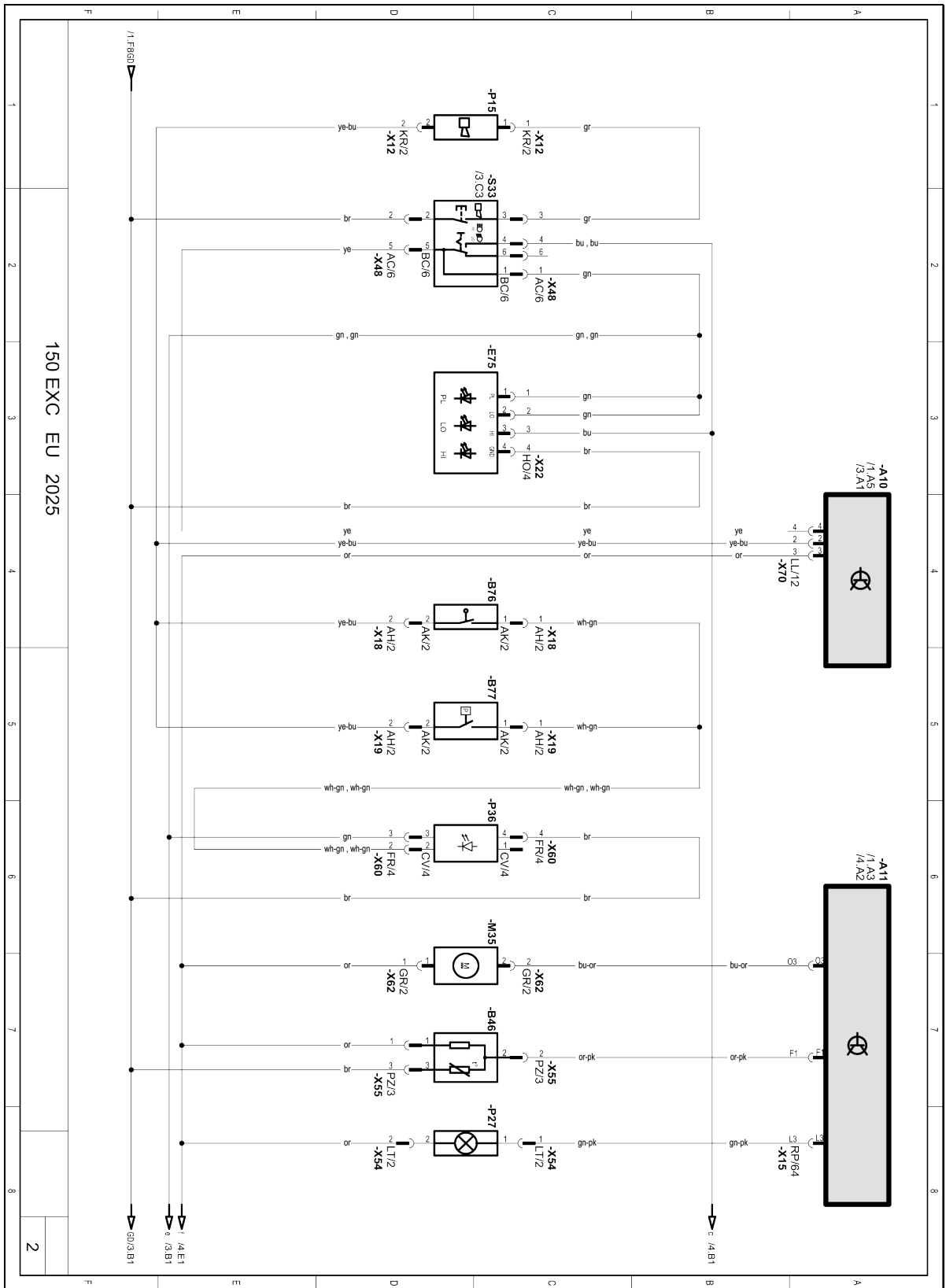

Components:

A10	Vehicle system control unit	M35	Oil pump
A11	Engine control unit	P15	Horn
B46	Oil level sensor	P27	Oil level warning lamp
B76	Front brake light switch	P36	Brake/tail light
B77	Rear brake light switch	S33	Combination switch, left
E75	Headlight unit		

Cable colors:

bl	black	or	Orange
br	brown	pk	Pink
bu	blue	pu	Violet
gn	green	rd	Red
gr	Gray	wh	White
lbu	Light blue	ye	Yellow

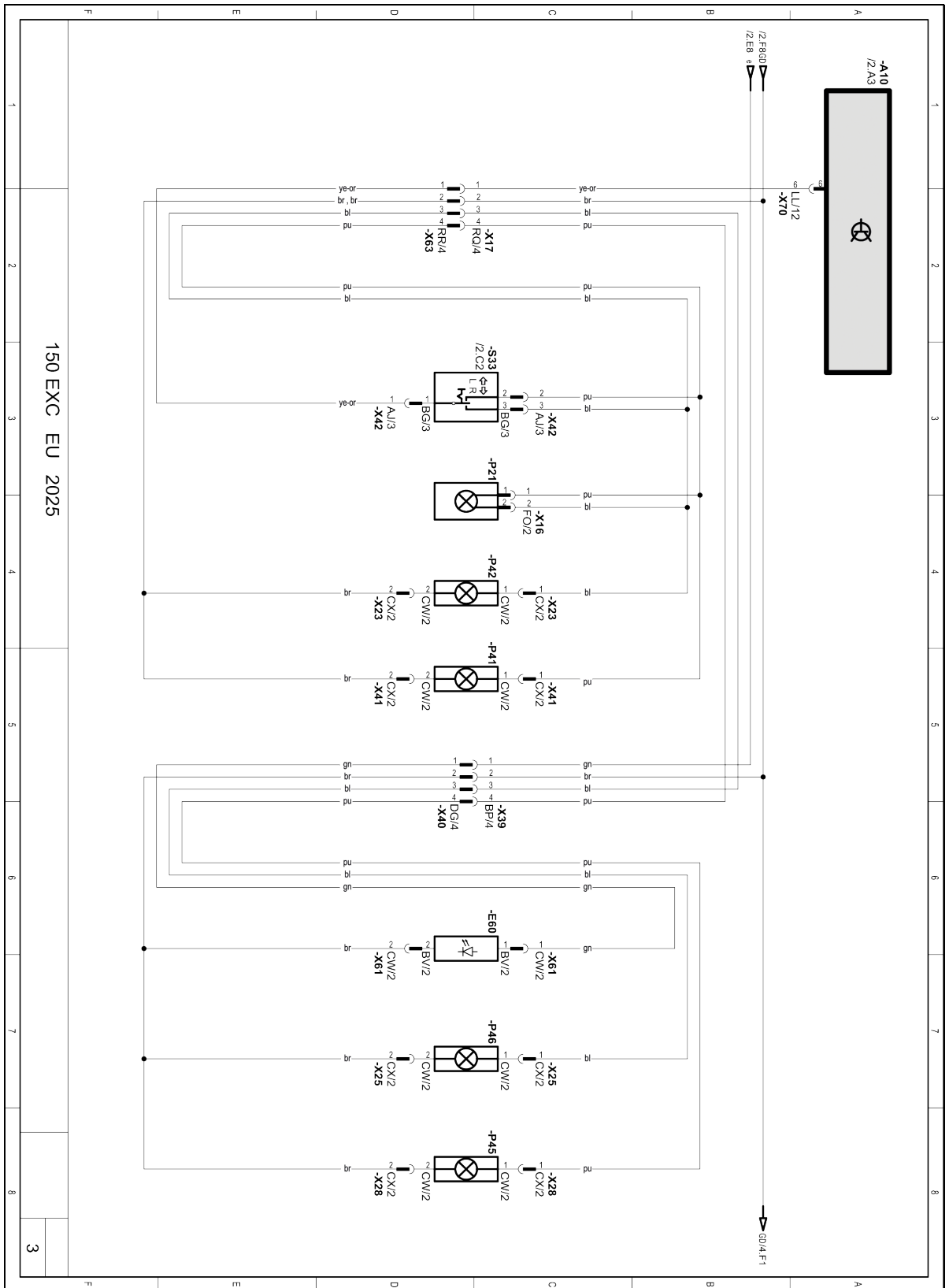

Components:

A10	Vehicle system control unit	P42	Turn signal, front right
E60	License plate lighting	P45	Turn signal, rear left
P21	Turn signal indicator lamp	P46	Turn signal, rear right
P41	Turn signal, front left	S33	Combination switch, left

Cable colors:

bl	black	or	Orange
br	brown	pk	Pink
bu	blue	pu	Violet
gn	green	rd	Red
gr	Gray	wh	White
lbu	Light blue	ye	Yellow

Components:

A11	Engine control unit	M51/2	Injection valve 2, cylinder 1
A41	Connectivity Unit (if installed)	P10	Dashboard
B32	Fuel level sensor	R30	Terminating resistor (if installed)
B70	Front wheel speed sensor	S53	Mapping selector switch (if installed)
M22	Exhaust control actuator	X295	Diagnostic connector
M51/1	Injection valve 1, cylinder 1		

Cable colors:

bl	black	or	Orange
br	brown	pk	Pink
bu	blue	pu	Violet
gn	green	rd	Red
gr	Gray	wh	White
lbu	Light blue	ye	Yellow

Components:

A11	Engine control unit	B41	Induction manifold pressure sensor
B12	Intake air temperature sensor	B43	Throttle valve position sensor
B13	Ambient air pressure sensor	B51	Lambda sensor (if installed)
B21	Coolant temperature sensor	M20	Purge valve
B26	Tilt sensor	R51	Ignition coil
B37	Crankshaft position sensor		

Cable colors:

bl	black	or	Orange
br	brown	pk	Pink
bu	blue	pu	Violet
gn	green	rd	Red
gr	Gray	wh	White
lbu	Light blue	ye	Yellow

6 Wiring diagram

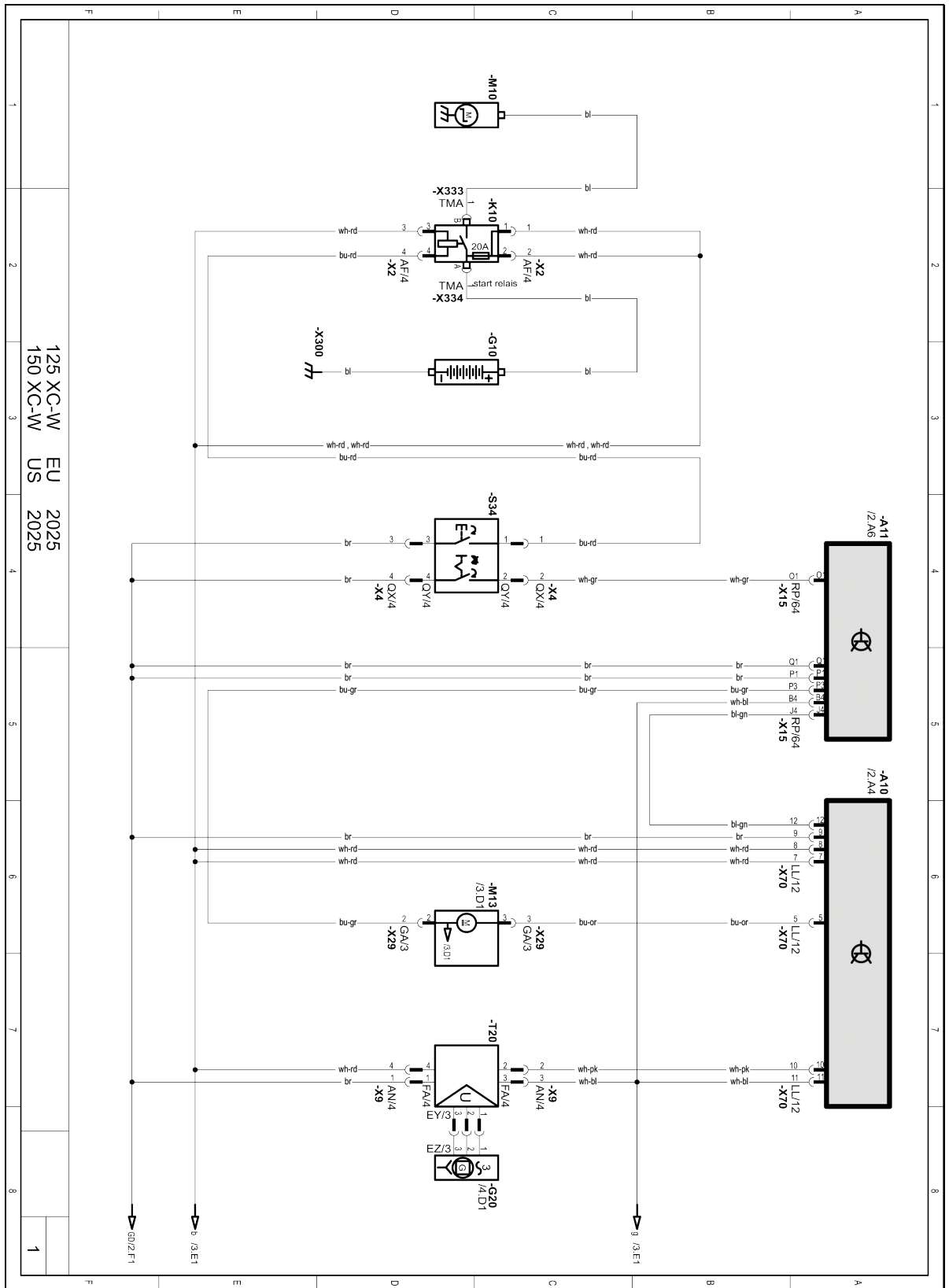

Components:

A10	Vehicle system control unit	M10	Starter motor
A11	Engine control unit	M13	Fuel pump
G10	12 V battery	S34	Combination switch, right
G20	Alternator	T20	Voltage regulator
K10	Starter relay with main fuse		

Cable colors:

bl	black	or	Orange
br	brown	pk	Pink
bu	blue	pu	Violet
gn	green	rd	Red
gr	Gray	wh	White
lbu	Light blue	ye	Yellow

6 Wiring diagram

6.7 Page 2 (All XC-W models)

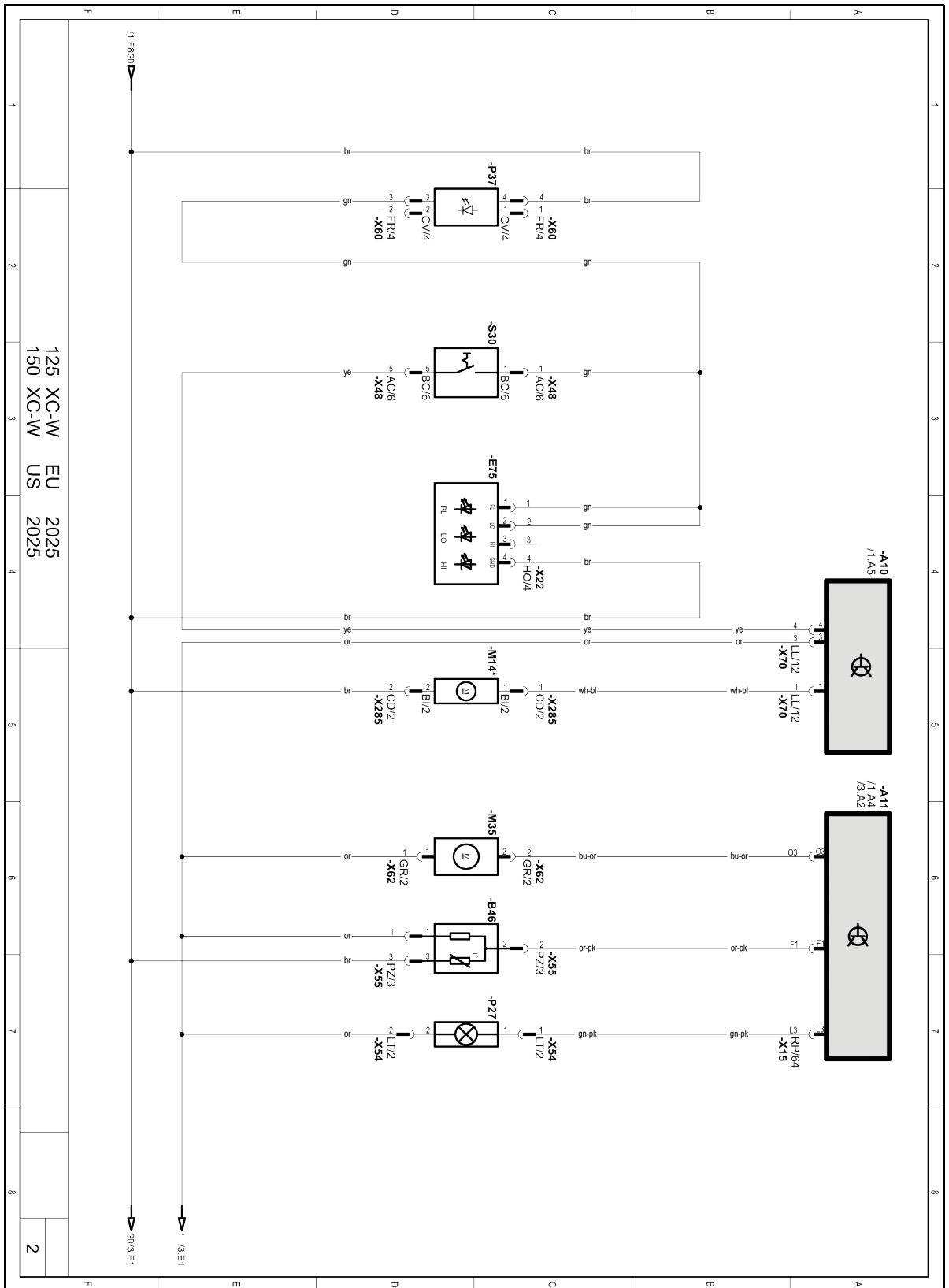

Components:

A10	Vehicle system control unit	M35	Oil pump
A11	Engine control unit	P27	Oil level warning lamp
B46	Oil level sensor	P37	Tail light
E75	Headlight unit	S30	Light switch
M14	Radiator fan (if installed)		

Cable colors:

bl	black	or	Orange
br	brown	pk	Pink
bu	blue	pu	Violet
gn	green	rd	Red
gr	Gray	wh	White
lbu	Light blue	ye	Yellow

Components:

A11	Engine control unit	M51/2	Injector 2, cylinder 1
A41	Connectivity Unit (if installed)	P10	Dashboard
B32	Fuel level sensor	R30	Terminating resistor (if installed)
B70	Front wheel speed sensor	S53	Mapping selector switch (if installed)
M22	Exhaust control actuator	X295	Diagnostic connector
M51/1	Injection valve 1, cylinder 1		

Cable colors:

bl	black	or	Orange
br	brown	pk	Pink
bu	blue	pu	Violet
gn	green	rd	Red
gr	Gray	wh	White
lbu	Light blue	ye	Yellow

Components:

A11	Engine control unit	B37	Crankshaft position sensor
B12	Intake air temperature sensor	B41	Induction manifold pressure sensor
B13	Ambient air pressure sensor	B43	Throttle valve position sensor
B21	Coolant temperature	R51	Ignition coil
B26	Tilt sensor		

Cable colors:

bl	black	or	Orange
br	brown	pk	Pink
bu	blue	pu	Violet
gn	green	rd	Red
gr	Gray	wh	White
lbu	Light blue	ye	Yellow

7 Connector overview

7.1 Diagnostics connector AP

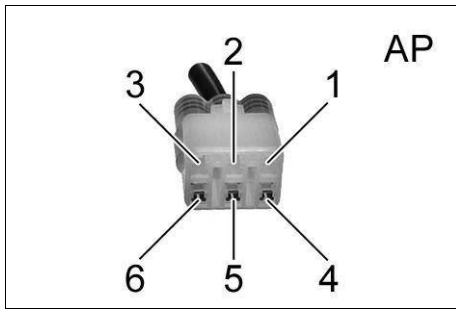

Pin overview

1	Power supply (terminal 15)
2	CAN high
3	CAN low
4	Not assigned
5	Not assigned
6	Ground

7.2 Tilt sensor connector AM

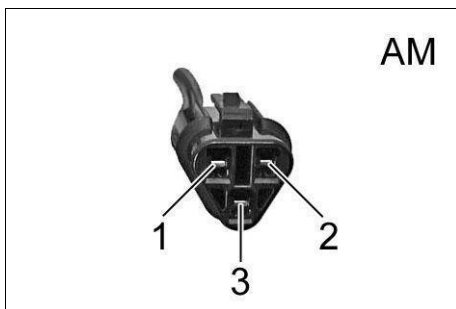

Pin overview

1	Sensor ground
2	Voltage supply
3	Signal wire

7.3 Tilt sensor connector AR

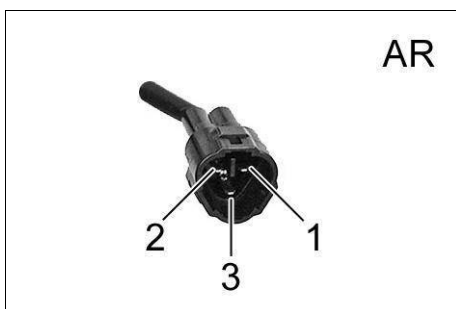

Pin overview

1	Sensor ground
2	Voltage supply
3	Signal wire

7.4 Crankshaft speed sensor connector AT

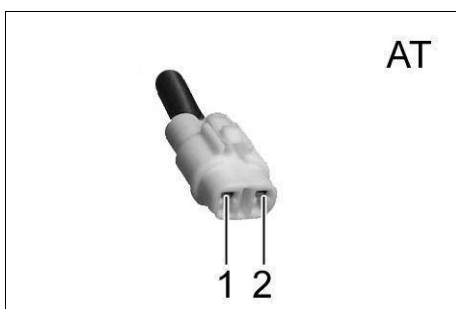

Pin overview

1	Signal wire
2	Signal wire

7.5 Ignition coil connector AW

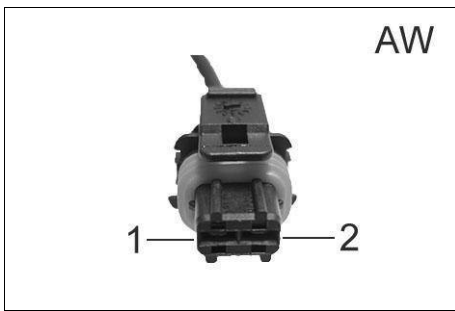

Pin overview

- | | |
|---|--------------|
| 1 | Control wire |
| 2 | Ground wire |

7.6 Intake air temperature sensor connector CM

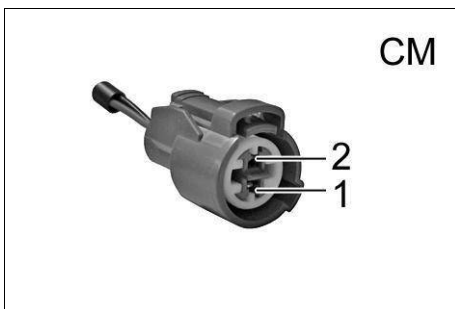

Pin overview

- | | |
|---|---------------|
| 1 | Sensor ground |
| 2 | Signal wire |

7.7 Fuel vapor valve connector DF



Pin overview

- | | |
|---|----------------|
| 1 | Control wire |
| 2 | Voltage supply |

7.8 Lambda sensor connector DY

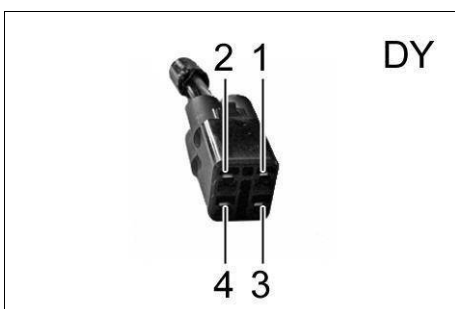

Pin overview

- | | |
|---|------------------------------------|
| 1 | Sensor ground |
| 2 | Signal wire |
| 3 | Power supply, lambda sensor heater |
| 4 | Control wire, lambda sensor heater |

7.9 Voltage regulator connector EY

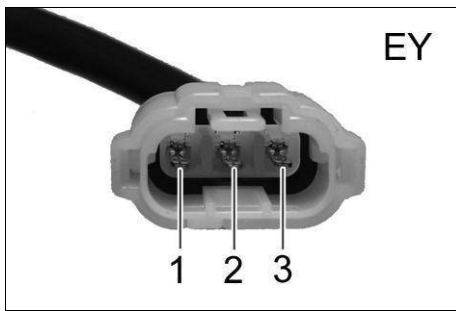

Pin overview

1	AC voltage, phase 1
2	Alternating voltage phase 2
3	Alternating voltage phase 3

7.10 Voltage regulator connector FA

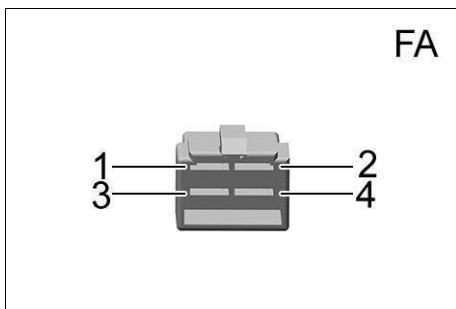

Pin overview

1	Ground (terminal 31)
2	Control wire
3	Control wire
4	Power supply (terminal 30)

7.11 Throttle valve position sensor circuit A, connector FT



Pin overview

1	Voltage supply
2	Signal wire
3	Sensor ground

7.12 Fuel pump, connector GA

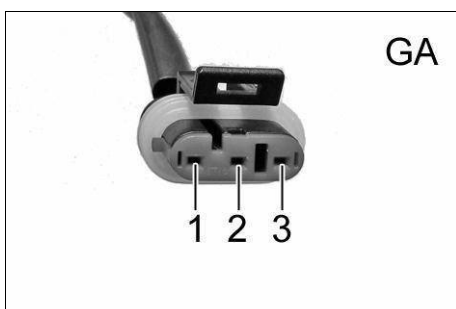

Pin overview

1	Signal wire, fuel level sensor
2	Control wire
3	Voltage supply

7.13 Oil pump connector GR

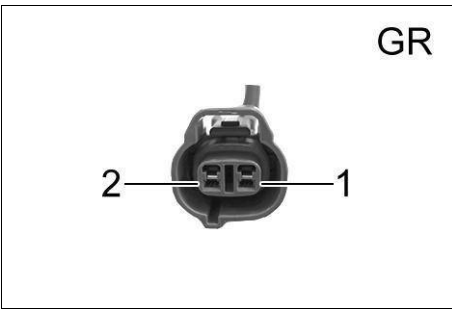

Pin overview

1	Power supply (terminal 15)
2	Control wire

7.14 Injector 1, cylinder 1, socket connector GQ

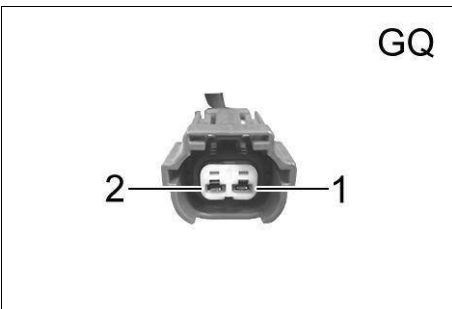

Pin overview

1	Control wire
2	Power supply (terminal 15)

7.15 Injection valve 2, cylinder 1, connector GQ

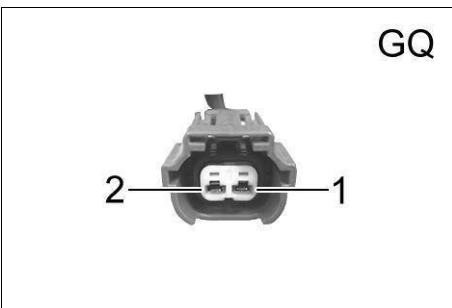

Pin overview

1	Control wire
2	Power supply (terminal 15)

7.16 Coolant temperature sensor connector HV

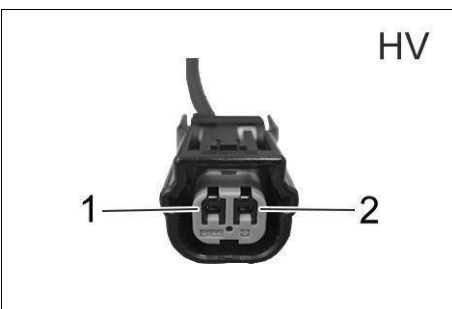

Pin overview

1	Signal wire
2	Sensor ground

7.17 Crankshaft speed sensor connector IF

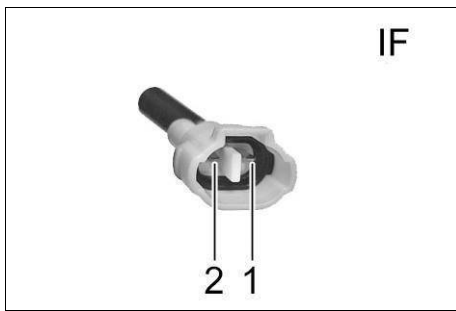

Pin overview

1	Signal wire
2	Signal wire

7.18 Lambda sensor connector IM

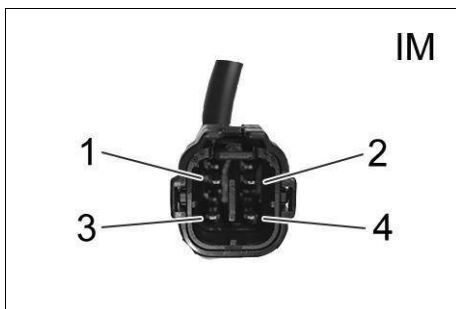

Pin overview

1	Sensor ground
2	Signal wire
3	Power supply, lambda sensor heater
4	Control wire, lambda sensor heater

7.19 Vehicle system control unit connector LL

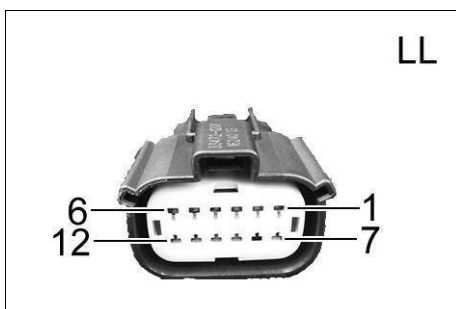

Pin overview

1	Control wire, radiator fan
2	Power supply (terminal 15)
3	Power supply (terminal 15)
4	Control wire, high beam
5	Control wire, fuel pump relay
6	Control wire, turn signal
7	Power supply (terminal 30)
8	Power supply (terminal 30)
9	Ground (terminal 31)
10	Control wire, voltage regulator
11	Control wire, voltage regulator
12	Signal wire, radiator fan

7.20 Oil lamp connector LT

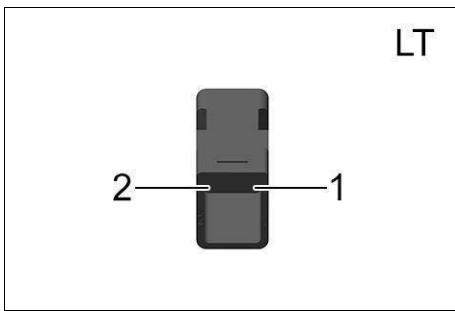

Pin overview

1	Control wire
2	Voltage supply

7.21 Crankcase pressure sensor connector LU

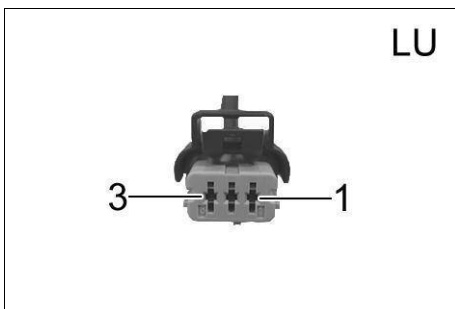

Pin overview

1	Voltage supply
2	Ground (terminal 31)
3	Signal wire

7.22 Ambient air pressure sensor connector LU

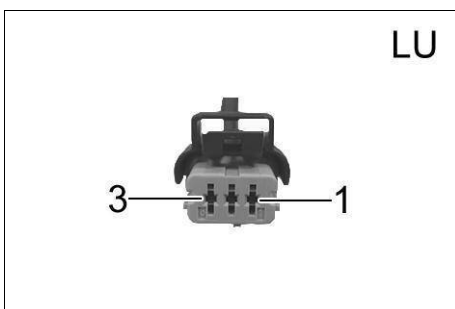

Pin overview

1	Voltage supply
2	Ground (terminal 31)
3	Signal wire

7.23 Connectivity Unit connector OJ

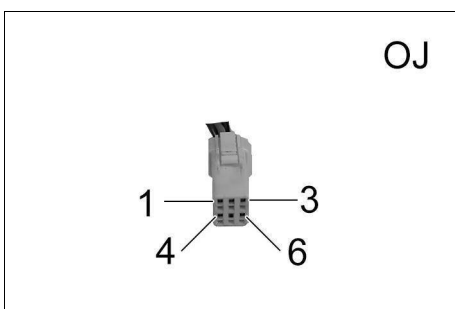

Pin overview

1	Power supply (terminal 15)
2	CAN high
3	CAN low
4	Ground
5	Ground
6	Power supply (terminal 30)

7.24 Exhaust control actuator socket connector ON

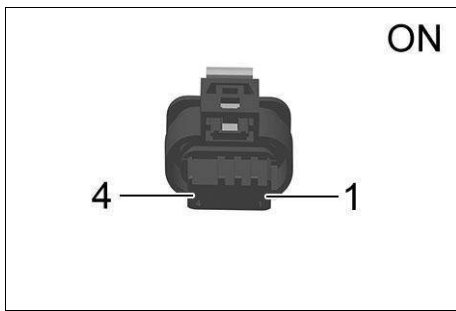

Pin overview

1	Ground
2	Control wire
3	Voltage supply
4	Signal wire

7.25 Oil level sensor connector PZ

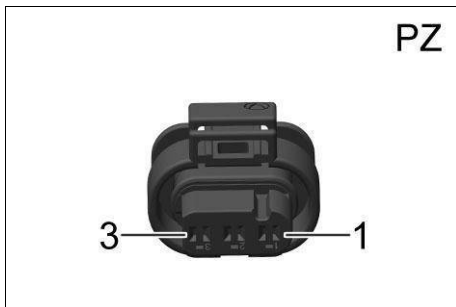

Pin overview

1	Voltage supply
2	Signal wire
3	Ground (terminal 31)

7.26 Map select switch connector QZ

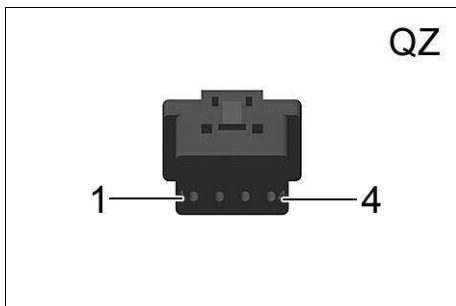

Pin overview

1	Voltage supply
2	CAN high
3	CAN low
4	Ground wire

7.27 Engine control unit connector RP

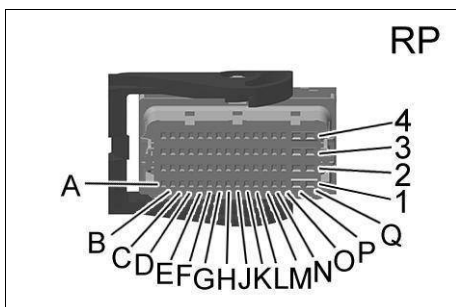

Pin overview

A1	Not assigned
A2	Not assigned
A3	Not assigned
A4	Not assigned
B1	Signal wire, exhaust control actuator
B2	Not assigned
B3	Not assigned
B4	Control wire, power relay
C1	Not assigned
C2	Ground wire 2

C3	Not assigned
C4	Power supply (terminal 15)
D1	Not assigned
D2	Voltage supply, sensors 2
D3	Power supply, sensors 1
D4	Power supply (terminal 15)
E1	Signal wire, crankcase pressure sensor
E2	Ground wire 1
E3	Not assigned
E4	CAN high
F1	Signal wire, oil level sensor
F2	Not assigned
F3	Not assigned
F4	CAN low
G1	Not assigned
G2	Signal wire, ambient air pressure sensor
G3	Signal wire, throttle valve position sensor circuit A
G4	Crankshaft speed sensor, plus
H1	Signal wire, lambda sensor
H2	Not assigned
H3	Not assigned
H4	Crankshaft speed sensor, ground
J1	Ground wire, sensor 4
J2	Ground wire, sensors 3
J3	Not assigned
J4	Control wire, radiator fan
K1	Signal wire, intake air temperature sensor
K2	Not assigned
K3	Signal wire, coolant temperature sensor
K4	Not assigned
L1	Not assigned
L2	Signal wire, tilting sensor
L3	Signal wire, oil level lamp
L4	Not assigned
M1	Not assigned
M2	Not assigned
M3	Control wire, injection valve 2
M4	Control wire, lambda sensor heater
N1	Not assigned
N2	Not assigned
N3	Control wire, malfunction indicator lamp
N4	Control wire, injection valve 1
O1	Control wire, stop button
O2	Not assigned

7 Connector overview

03	Control wire, oil pump
04	Control wire, fuel vapor valve
P1	Ground (terminal 31)
P2	Control wire, exhaust control actuator
P3	Control wire, fuel pump relay
P4	Not assigned
Q1	Ground (terminal 31)
Q2	Not assigned
Q3	Control wire, ignition coil
Q4	Power supply (terminal 15)

A Tools

A.1 Tool overview

Diagnostics tablet

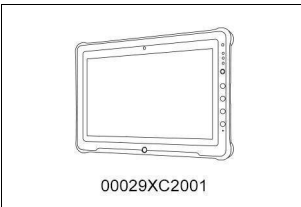

Order details

- 00029XC2001

Application areas

- Getac F110 diagnostics tablet with software for vehicle diagnostics

Hand strap

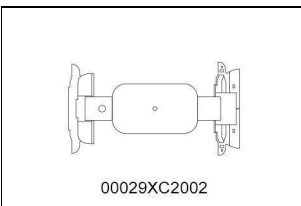

Order details

- 00029XC2002

Application areas

- Handle for diagnostic tablet

Charger

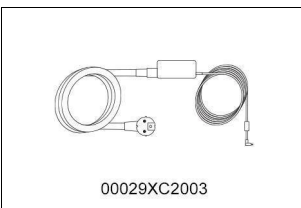

Order details

- 00029XC2003

Application areas

- Battery charger and power supply unit for Getac F110 diagnostics tablet

VCI

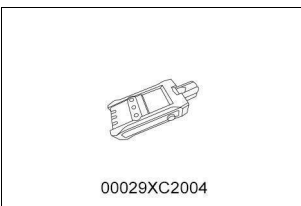

Order details

- 00029XC2004

Application areas

- The Vehicle Communication Interface (VCI) is connected to the diagnostic connector of the vehicle and the diagnostics tablet

VCI attachment

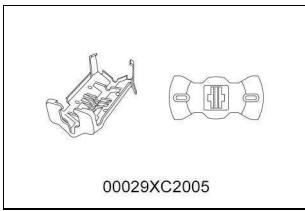

Order details

- 00029XC2005

Application areas

- Attachment for the VCI including an attachment for the fuel tank

Protective film



Order details

- 00029XC2006

Application areas

- Protective film for the touchscreen of the Getac F110 diagnostics tablet

Diagnostics cable extension

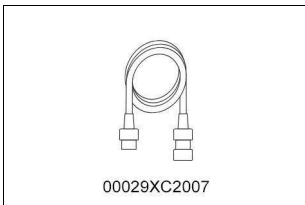

Order details

- 00029XC2007

Properties

- Length approx. 1.15 m
(3 ft – 9.28 in)

Application areas

- Extension cables between VCI and diagnostic connector on the vehicle

USB cable



Order details

- 00029XC2008

Properties

- Length approx. 5 m
(16 ft – 5 in)

Application areas

- USB cable type A to ODU MINI-SNAP Series L (diagnostics tablet to VCI)

12-V power supply cable

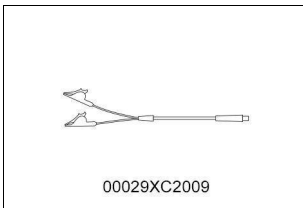

Order details

- 00029XC2009

Application areas

- External power supply for the VCI for vehicles without 12-V battery and for flashing of specific control units

RideRecorder trigger



Order details

- 00029XC2010

Application areas

- Tip switch for triggering a marker while recording measurement data

Case



Order details

- 00029XC2011

Application areas

- Case including inlay for storing the VCI and all cables and adapters for diagnosis

Docking station



Order details

- 00029XC2012

Application areas

- Docking station for the Getac F110 diagnostics tablet

Wall attachment

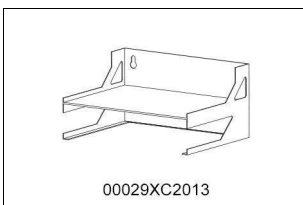

Order details

- 00029XC2013

Application areas

- Device for securing on the wall

Battery

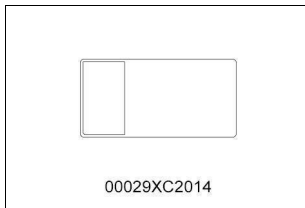

Order details

- 00029XC2014

Application areas

- Battery for the Getac F110 diagnostics tablet

Input stylus

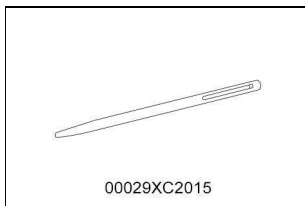

Order details

- 00029XC2015

Application areas

- Stylus for input via the touch screen of the Getac F110 diagnostics tablet

Cable connector unlocking kit

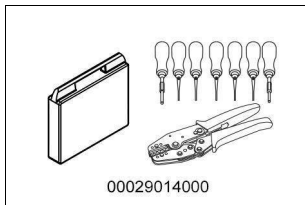

Order details

- 00029014000

Application areas

- Pinout kit including case and crimping pliers for repairing wiring harnesses or replacing the most common connectors

Break out box



Order details

- 00029095001

Application areas

- Box with connector board (without adapter and templates) for performing various electrical measurements on the wiring harness

Adapter and template VITESCO

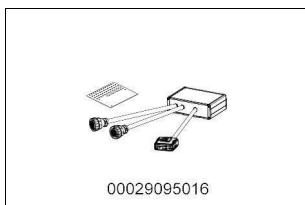

Order details

- 00029095016

Application areas

- Adapter cable and template for performing various electrical measurements on the wiring harness

B Technical terms

OBD	On-board diagnosis	Vehicle system, which monitors the specified parameters of the vehicle electronics
-----	--------------------	--

A	
Ambient air pressure sensor	22
C	
Circuit A throttle valve position sensor	21
Connectivity Unit	24
Coolant temperature sensor	14
Crankcase pressure sensor	18
Crankshaft position sensor	15
D	
Diagnostic connector	19
E	
Engine control unit	23
Exhaust control actuator	24
F	
Fuel pump	9
I	
Idle speed adjustment screw	22
Ignition coil	16
Injection valves	20
Intake air temperature sensor	19
L	
Lambda sensor heater	12
O	
Oil level sensor	18
Oil pump	17
Oxygen sensor	13
P	
Purge valve	19
R	
Regulator rectifier	10
Rollover sensor	23
V	
Vehicle system control unit	10
W	
Wiring diagram	194, 196, 198, 200, 202, 204, 206, 208, 210



3240165en

04/03/2025

