



**REPARATURANLEITUNG**  
**REPAIR MANUAL**  
**MANUEL DE RÉPARATION**

**MOTOR**  
**ENGINE**  
**MOTEUR**

**S5-E / S5-T / S5-GS**



**3.97**  
**ART. NR. 3.205.19**

**'97**

## INTRODUCTION

THIS REPAIR MANUAL OFFERS EXTENSIV REPAIR-INSTRUCTIONS AND IS AN UP-TO-DATE VERSION THAT DESCRIBES THE LATEST MODELS OF THE SERIES. HOWEVER, THE RIGHT TO MODIFICATIONS IN THE INTEREST OF TECHNICAL IMPROVEMENT IS RESERVED WITHOUT UPDATING THE CURRENT ISSUE OF THIS MANUAL.

A DESCRIPTION OF GENERAL WORKING MODES COMMON IN WORK SHOPS HAS NOT BEEN INCLUDED. SAFETY RULES COMMON IN THE WORK SHOP HAVE ALSO NOT BEEN LISTED. WE TAKE IT FOR GRANTED THAT THE REPAIRS ARE MADE BY QUALIFIED PROFESIONALLY TRAINED MECHANICS.

READ THROUGH THE REPAIR MANUAL BEFORE BEGINNING WITH THE REPAIR WORK.

---

⚠                      **WARNING**                      ⚠

---

**STRICT COMPLIANCE WITH THESE INSTRUCTIONS IS ESSENTIAL TO AVOID DANGER TO LIFE AND LIMB.**

---

---

!                      **CAUTION**                      !

---

**NON-COMPLIANCE WITH THESE INSTRUCTIONS CAN LEAD TO DAMAGE OF MOTORCYCLE COMPONENTS OR RENDER MOTORCYCLES UNFIT FOR TRAFFIC !**

---

„NOTE” POINTS OUT USEFUL TIPS.

USE ONLY **ORIGINAL KTM SPARE PARTS** WHEN REPLACING PARTS.

THE ENGINE IS ONLY ABLE TO MEET USER EXPECTATIONS IF THE MAINTENANCE WORK IS PERFORMED REGULARLY AND PROFESSIONALLY.

FOR TECHNICAL DATA SEE LAST SECTION OF THIS MANUAL. UP-TO-DATE INFORMATION IS PUBLISHED IN OUR UPDATED SPARE PARTS CATALOGUES.



KTM AUSTRIA'S CERTIFICATE OF ACHIEVEMENT FOR ITS QUALITY SYSTEM ISO 9001 IS THE BEGINNING OF AN ON- GOING TOTAL RE-ENGINEERED QUALITY PLAN FOR A BRIGHTER TOMORROW.

KTM SPORTMOTORCYCLE AKTIENGESELLSCHAFT  
5230 MATTIGHOFEN, AUSTRIA

ALL DESIGN AND ASSEMBLY MODIFICATION RIGHTS RESERVED.

# INDEX

	Page
1.0	<b>SPECIAL TOOLS</b> .....3
2.0	<b>REMOVING THE ENGINE</b> .....3
3.0	<b>DISASSEMBLING THE ENGINE</b> .....4
3.1	Draining the gear oil .....4
3.2	Ignition .....4
3.3	Engine sprocket .....5
3.4	Cylinder head, cylinder .....5
3.5	Piston .....6
3.6	Kickstarter .....6
3.7	Clutch, primary drive .....7
3.8	Separating the two housing halves .....8
3.9	Crankshaft, countershaft .....8
4.0	<b>WORK ON INDIVIDUAL COMPONENTS</b> .....9
4.1	Left housing half .....9
4.2	Right housing half .....9
4.3	Piston .....10
4.3.1	Checking the piston ring end gap .....10
4.4	Measuring piston and cylinder, piston fitting clearance .....10
4.5	Crankshaft .....11
4.6	Reed valve housing (S5-T) .....11
4.6.1	Reed valve housing (S5-GS) .....11
4.7	Clutch cover .....12
4.8	Kickstarter shaft .....12
4.8.1	Preassembling of kickstarter shaft .....13
4.9	Centrifugal clutch, primary drive .....13
4.10	Exchanging the clutch shoes .....13
5.0	<b>ASSEMBLING THE ENGINE</b> .....14
5.1	Mounting the crankshaft .....14
5.2	Assembling the housing .....14
5.3	Engine sprocket .....14
5.4	Chain securing guide .....14
5.5	Mount flywheel .....14
5.6	Mount and set the ignition coil .....15
5.7	Piston, cylinder .....16
5.8	Cylinder head .....16
5.9	Primary drive, clutch .....16
5.10	Kickstarter .....17
5.11	Gear oil .....18
6.0	<b>INSTALLING THE ENGINE</b> .....18
7.0	<b>TECHNICAL DATA - ENGINE</b> .....19
7.1	Tolerances and fitting clearances .....20
7.2	Tightening torques .....20
7.3	Basic carburetor setting .....20
8.0	<b>PERIODIC MAINTENANCE SCHEDULE</b> .....21

## 1.0 SPECIAL TOOLS

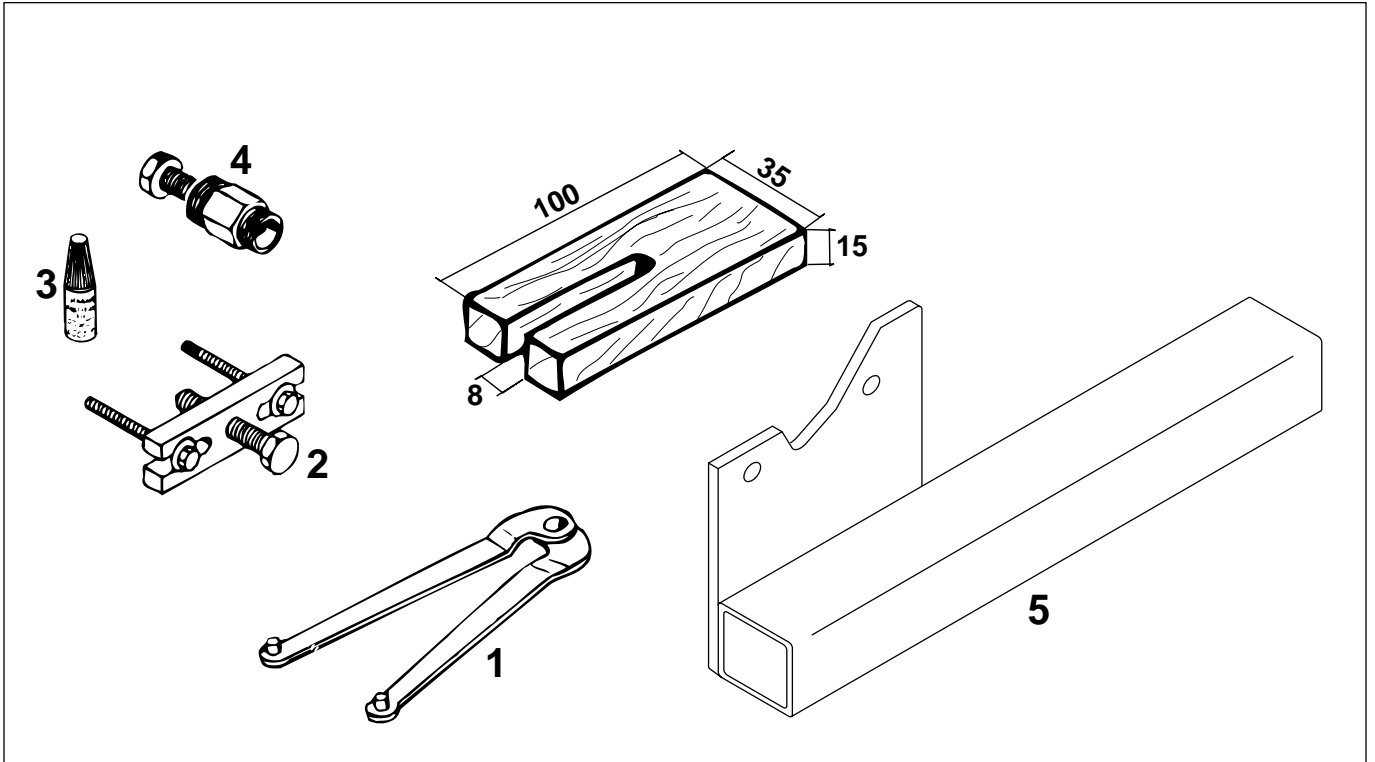
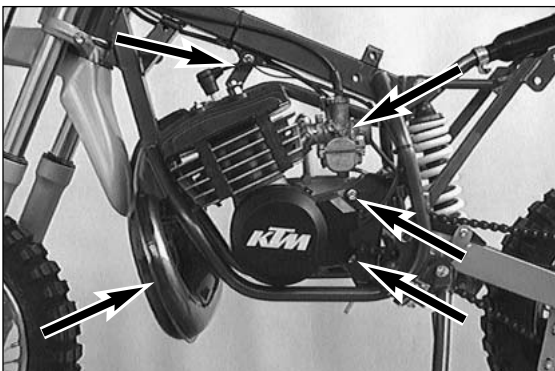
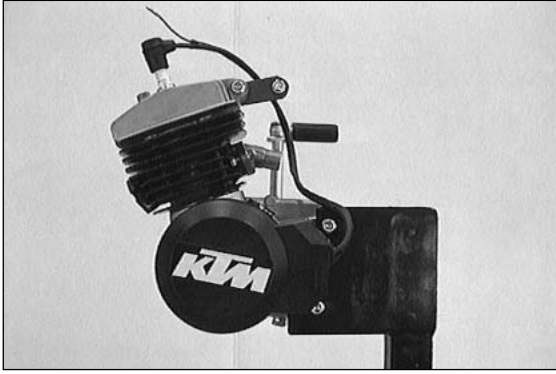

FIG.	DESCRIPTION	PART NR.
1	Holding wrench for flywheel and clutch hub	151.12.021.000
2	Extractor for clutch hub and primary gear	160.12.005.000
3	Loctite 242 blue	6.899.785
4	Extractor for flywheel	151.12.009.000
5	Engine holder	450.29.001.000



## 2.0 REMOVING THE ENGINE

- Clean motorcycle
- Remove seat, subframe and fuel tank.
- Remove exhaust pipe, carburetor and chain.
- Disconnect the cable of the short circuit button.
- Remove engine screws, engine supports and carefully take engine out of the frame on the right side.



### 3.0 DISASSEMBLING THE ENGINE

- Secure the engine with two screws (M8 x 45) in the engine holder.

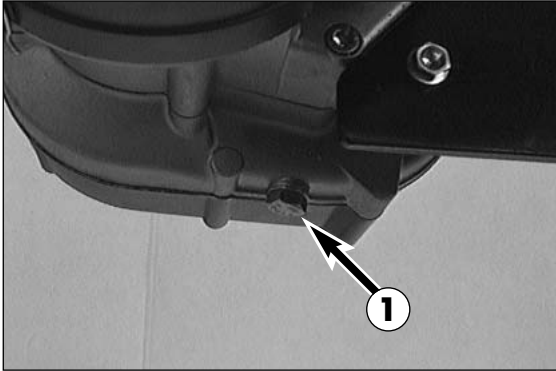

#### 3.1 Draining the gear oil

- Remove the gear oil drain plug **1** and the seal ring and drain the gear oil.

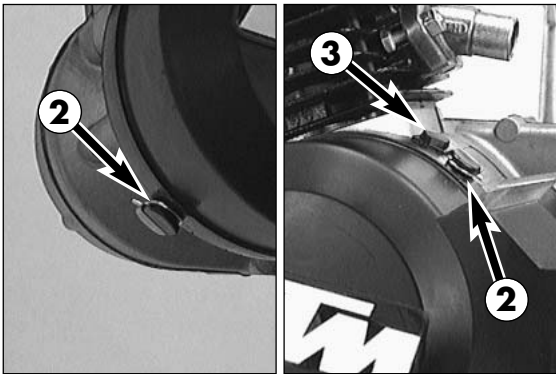

#### 3.2 Ignition

- Remove the two retaining springs **2** and lift off the ignition cover.
- Take the rubber **3** out of the opening in the housing.

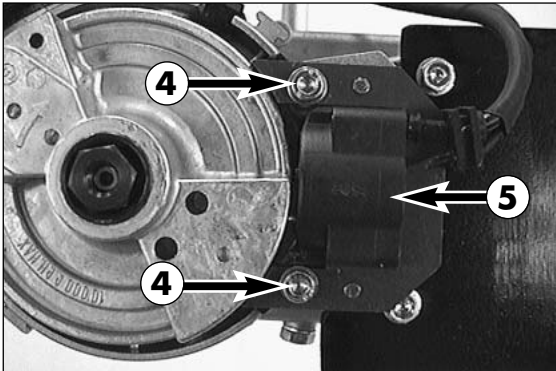

- Disconnect the spark plug connector from the spark plug.
- Remove the two screws **4** and washers and take off the ignition coil **5**.

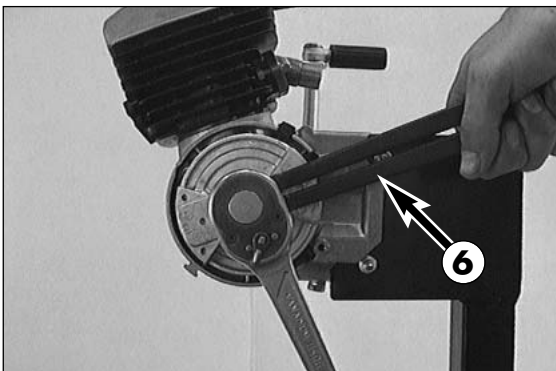

- Insert the holding wrench **6** into the two bores of the flywheel and hold the flywheel.
- Unscrew the hexagon nut of the flywheel.

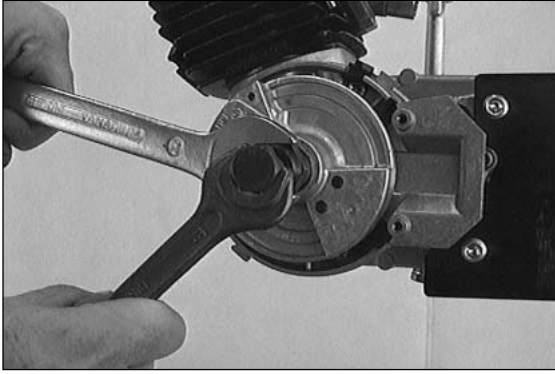

- Mount the extractor and pull off the flywheel.
- Take the woodruff key out of the crankshaft.

!

**CAUTION**

!

NEVER USE A HAMMER OR A SIMILAR TOOL ON THE FLYWHEEL.

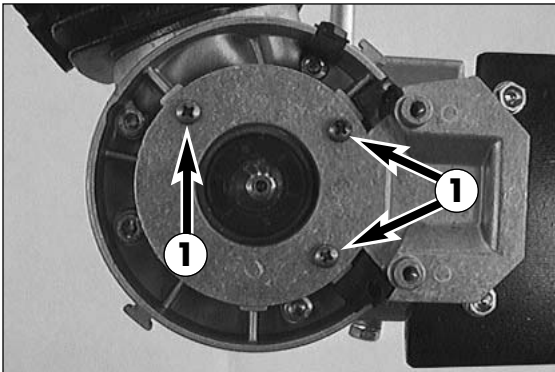

- Remove the 3 screws ❶ and take off the base plate.

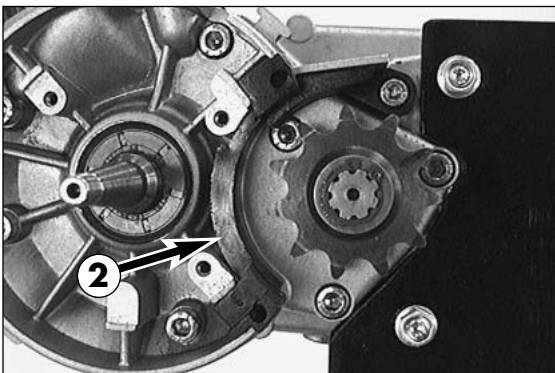

### 3.3 Engine sprocket

- Remove the Seeger circlip and the washer behind the circlip and pull the engine sprocket off the countershaft.
- Pull the flywheel rubber ❷ off.

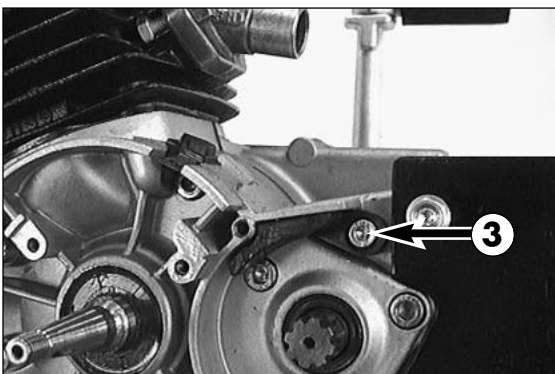

- Remove screw ❸ and take off the chain securing guide.

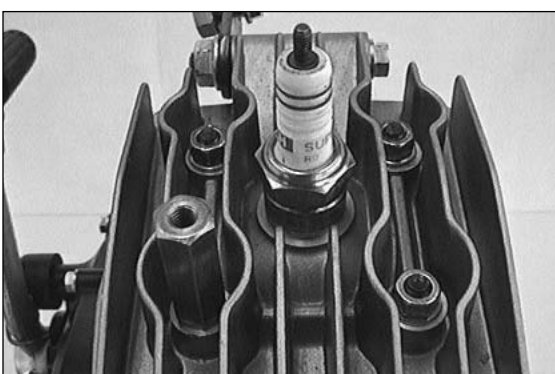

### 3.4 Cylinder head, cylinder

- Twist out the spark plug.
- Undo the 4 hexagon nuts and remove the cylinder head with cylinder head gasket.

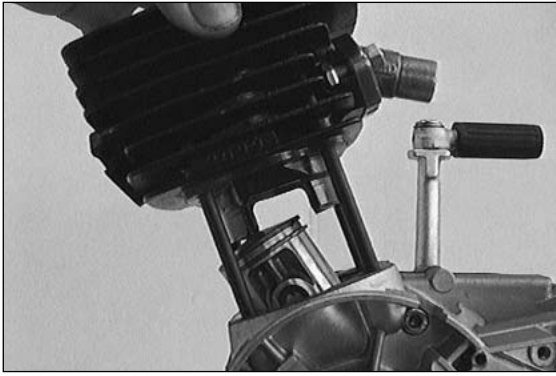

- Lift the cylinder off the studs.

NOTE: WHEN REMOVING THE CYLINDER MAKE SURE THAT THE PISTON DOESN'T HIT THE HOUSING.

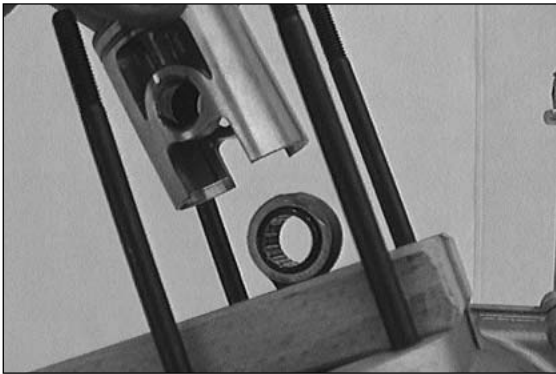

### 3.5 Piston

- Place the piston on the wooden fork.
- Remove the piston pin locking devices and push the piston pins out of the piston without applying force.
- Remove the piston.
- Take the piston pin bearing out of the conrod eye.

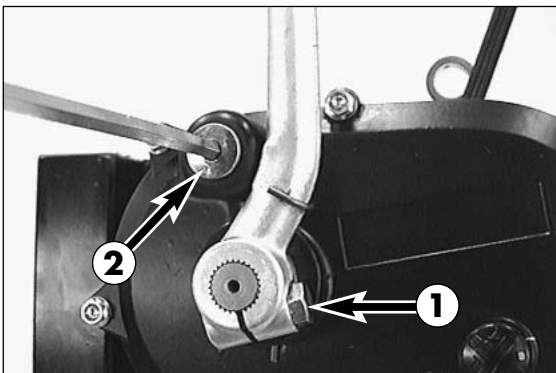

### 3.6 Kickstarter

- Remove screw 1.
- Hold the kickstarter and remove the kickstarter stop screw 2.
- Release the kickstarter spring by releasing the kickstarter.

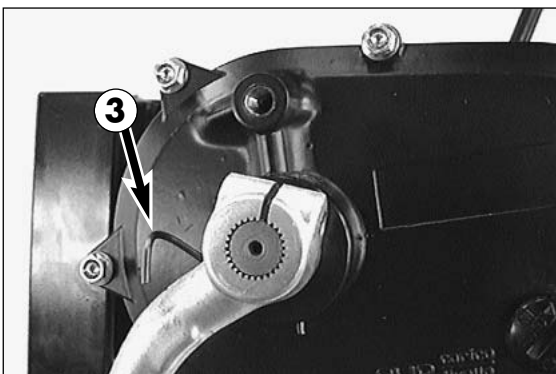

- Unhook the kickstarter spring 3 and pull the kickstarter off the kickstarter shaft.

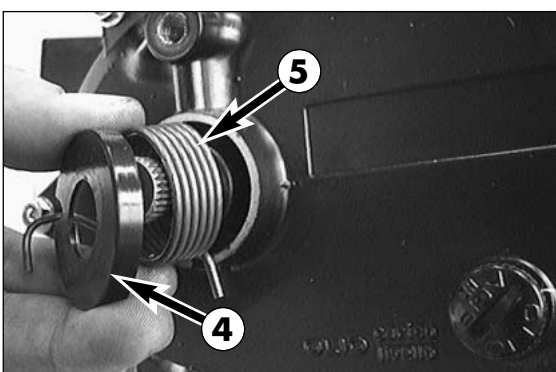

- Take the plastic cap 4 and the kickstarter spring 5 off the kickstarter shaft.

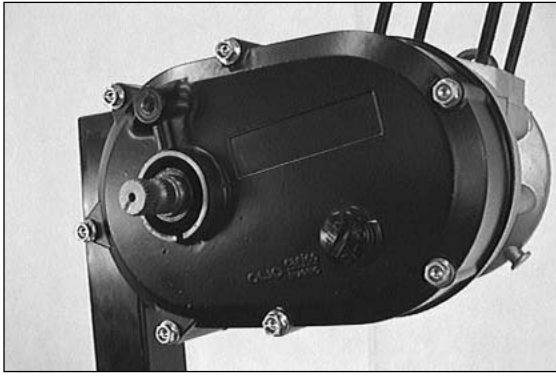

### 3.7 Clutch, primary drive

- Remove all 7 screws and lift off the clutch cover and the gasket.

NOTE: WHEN REMOVING THE CLUTCH COVER KEEP IN MIND THE STOP DISK OF THE KICK-STARTER SHAFT (CAN STICK TO THE INSIDE OF THE CLUTCH COVER).

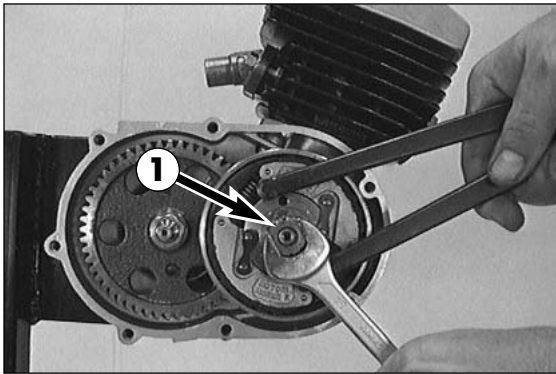

- Hold the clutch hub with the holding wrench and undo nut ❶ (LH thread).
- Remove nut and washer.

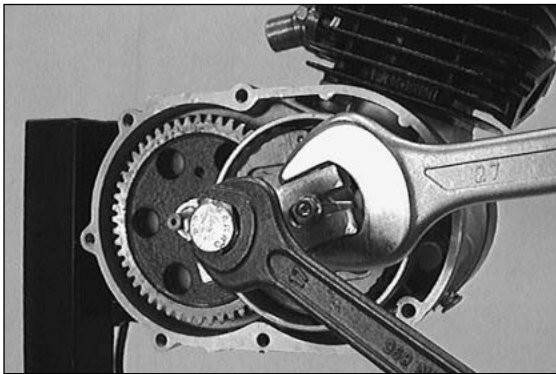

- Mount the extractor and pull off the clutch hub.

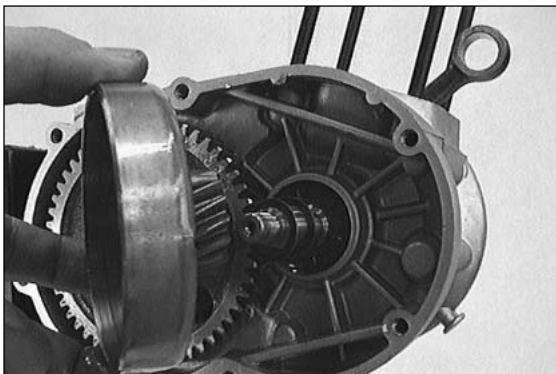

- Remove the clutch drum together with the two washers located behind it.

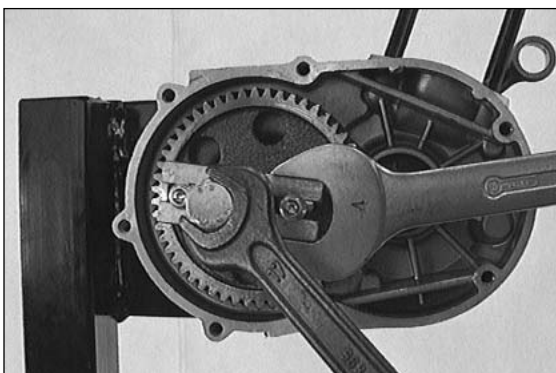

- Hold the primary gear with the holding wrench and undo the hexagon nut.
- Remove hexagon nut and washer.
- Mount the extractor and pull the primary gear off the countershaft.



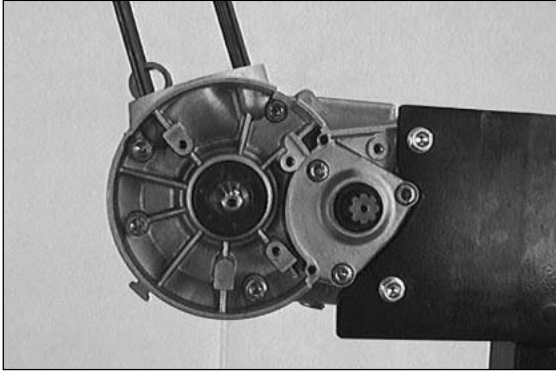

### 3.8 Separating the two housing halves

- Remove all 7 housing screws and clamp the engine holder together with the engine sideways into the vise in such a way that the clutch side of the engine is on top.

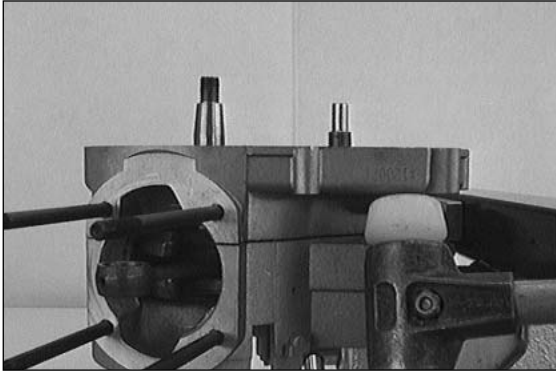

- Lightly tap the right housing half with a rubber hammer until the housing half can be removed.

NOTE: WHEN REMOVING THE HOUSING HALF KEEP IN MIND THE STOP DISK OF THE COUNTERSHAFT (CAN STICK TO THE INSIDE OF THE HOUSING).

- Remove the housing gasket.
- Take the stop disk off the countershaft.

**! CAUTION !**

TO PREVENT DAMAGING OF THE SEALING SURFACES, NEVER FORCE THE ENGINE HALVES APART WITH A SCREWDRIVER OR SIMILAR TOOL.

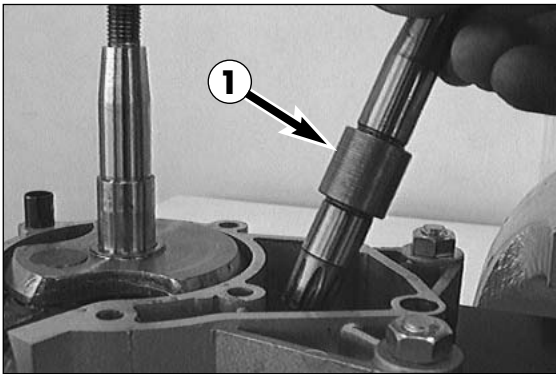

### 3.9 Crankshaft, countershaft

- Pull the countershaft ❶ out of the bearing.

NOTE: A RUBBER HAMMER CAN BE USED ON THE COUNTERSHAFT CAREFULLY IF IT IS NOT POSSIBLE TO PULL THE COUNTERSHAFT OUT OF THE BEARING MANUALLY.

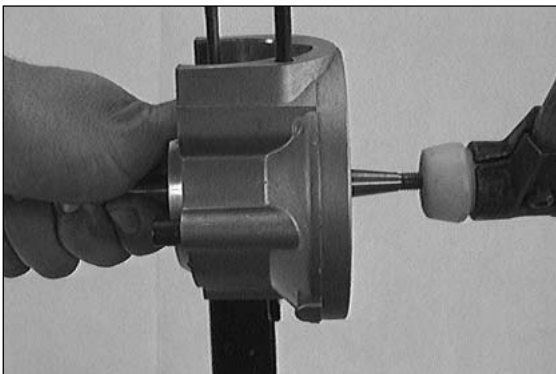

- Carefully tap the crankshaft with a rubber hammer to take it out of the left housing half.
- Clean all parts and check for damage.

## 4.0 WORK TO BE PERFORMED ON INDIVIDUAL COMPONENTS

### ENGINE HOUSING

NOTE: READ THROUGH THE FOLLOWING SECTION BEFORE COMMENCING WORK. THEN DETERMINE IN WHICH ORDER THE PARTS MUST BE MOUNTED TO ENSURE THAT THE HOUSING HALVES NEED NOT BE HEATED MORE THAN ONCE TO INSERT THE BEARINGS.

BEFORE PRESSING OR - IF NECESSARY - HAMMERING OUT THE BEARINGS, PLACE THE HOUSING HALVES ON A SUFFICIENTLY LARGE PLANE SURFACE (AFTER REMOVING THE DOWEL PINS). TO PREVENT DAMAGING OF THE SEALING SURFACE, ENSURE THAT THE ENTIRE SEALING SURFACE OF THE HOUSING IS PROPERLY RESTING ON THE SUPPORTING SURFACE. WE RECOMMEND TO PLACE THE HOUSING HALVES ON A WOODEN BOARD.

A MANDREL SHOULD NOT BE USED TO INSERT BEARINGS OR SHAFT SEAL RINGS. HOWEVER, IF A SUITABLE PRESSING DEVICE IS NOT AVAILABLE, A MANDREL CAN BE USED VERY CAREFULLY TO INSERT BEARINGS OR SHAFT SEAL RINGS. AT A HOUSING TEMPERATURE OF APPROXIMATELY 150° C, THE COLD BEARINGS WILL SLIDE INTO THEIR SEATS QUITE EASILY ANYHOW, REQUIRING ALMOST NO ADDITIONAL ATTENTION.

IF THE BEARINGS ARE NOT LOCKED TIGHT IN THEIR SEATS AFTER COOLING, THEY MUST BE EXPECTED TO CHANGE THEIR POSITION WITHIN THE HOUSING AS THE UNIT HEATS UP. IN THIS CASE, THE HOUSING MUST BE REPLACED.

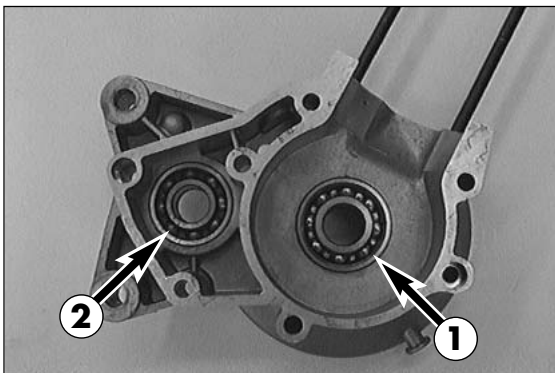

### 4.1 Left housing half

Remove the shaft seal rings and heat the housing half, using a hot plate, to a temperature of approximately 150° C.

#### GROOVED BALL BEARING OF THE CRANKSHAFT ①

Use a suitable mandrel to press the grooved ball bearing inwards.

Insert a new grooved ball bearing from inside, pressing it all the way into the recess.

#### GROOVED BALL BEARING OF THE COUNTERSHAFT ②

Use a suitable mandrel to press the grooved ball bearing inwards.

Insert a new grooved ball bearing from inside, pressing it all the way into the recess.

**! CAUTION !**

APPLY ONLY SLIGHT PRESSURE WHEN INSERTING GROOVED BALL BEARING INTO THE HOUSING SO AS TO PREVENT DAMAGING OF THE HOUSING.

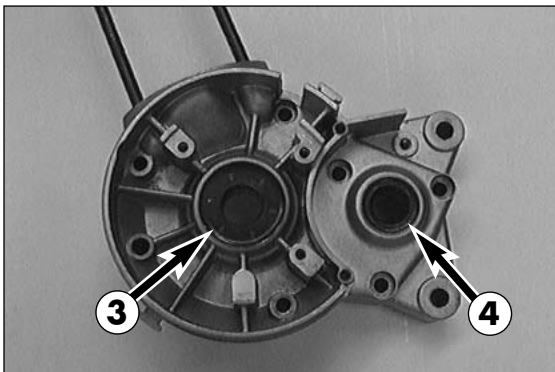

#### SHAFT SEAL RING OF THE CRANKSHAFT ③

Insert a new shaft seal ring from outside, the sealing lip facing inwards. The seal ring must be 2 mm (0.08 in.) below the edge of the housing.

#### SHAFT SEAL RING OF THE COUNTERSHAFT ④

Insert a new shaft seal ring from outside, the sealing lip facing inwards. The seal ring must be flush with the edge of the housing.

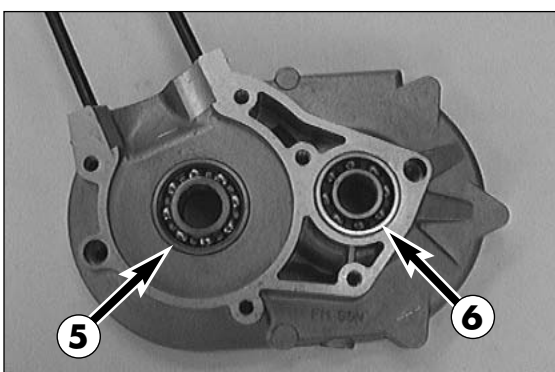

### 4.2 Right housing half

Remove the shaft seal ring and heat the housing half, using a hot plate, to a temperature of approximately 150° C.

#### GROOVED BALL BEARING OF THE CRANKSHAFT ⑤

Use a suitable mandrel to press the grooved ball bearing inwards.

Insert a new grooved ball bearing from inside, pressing it all the way into the recess.

#### GROOVED BALL BEARING OF THE COUNTERSHAFT ⑥

Use a suitable mandrel to press the grooved ball bearing inwards.

Insert a new grooved ball bearing from inside, pressing it all the way into the recess.

**! CAUTION !**

APPLY ONLY SLIGHT PRESSURE WHEN INSERTING GROOVED BALL BEARING INTO THE HOUSING SO AS TO PREVENT DAMAGING OF THE HOUSING.

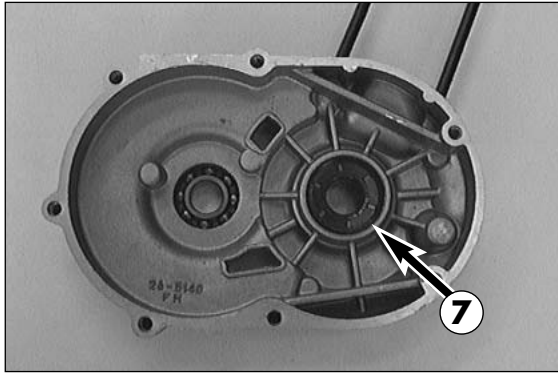

**SHAFT SEAL RING OF THE CRANKSHAFT 7**

Insert a new shaft seal ring from outside, the sealing lip facing inwards. The seal ring must be 2 mm (0.08 in.) below the edge of the housing.

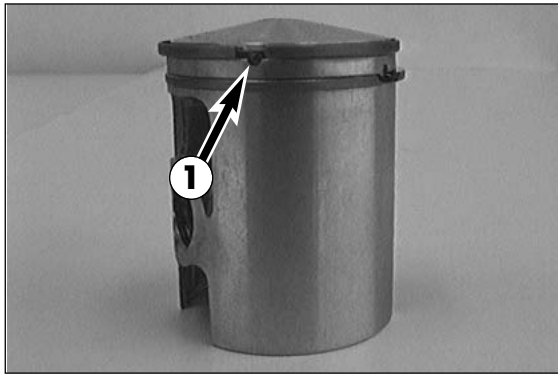

**4.3 Piston**

When intending to reinstall a used piston, perform the following checks:

- Check the piston bearing surface for signs of wear (seizing of the piston). Superficial grooves can be removed using a fine-grained abrasive block.
- The piston rings should not stick in their grooves. To clean the grooves, use an old piston ring or abrasive paper.
- The piston-ring locking devices 1 must fit tightly into the piston and should not be worn.
- The piston pin should not be discolored or significantly grooved.

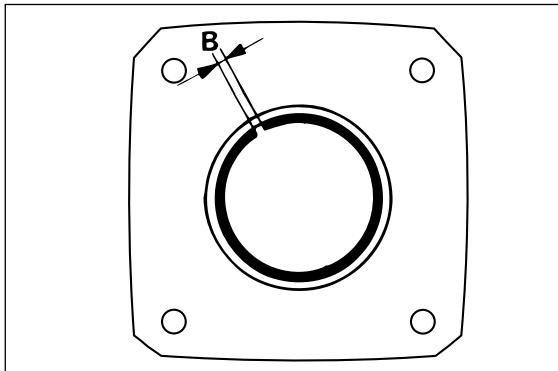

**4.3.1 Checking the piston ring end gap**

- Check the piston rings for signs of wear (grooves).
- Check the piston ring end gap B.
- Align the piston ring with the piston approximately 10 mm (0.4 in.) below the upper cylinder edge.
- Use a feeler gauge to measure the end gap B.

END GAP: MAX. 0.55 mm (0.022 in.)

IF THE END GAP EXCEEDS THIS LIMIT, CHECK PISTON AND CYLINDER FOR WEAR (FOR WEAR LIMITS REFER TO THE TECHNICAL SPECIFICATIONS). IF BOTH PISTON AND CYLINDER WEAR ARE WITHIN THE ADMISSIBLE LIMITS, REPLACE THE PISTON RINGS.

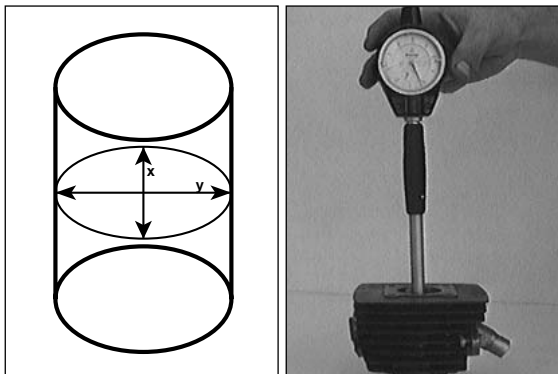

**4.4 Measuring piston and cylinder, piston fitting clearance**

- To determine cylinder wear, measure the cylinder, applying a micrometer to the middle of the bearing surface.
- Measure the cylinder diameter along both the x-axis and y-axis to determine ovality, if any.



- The piston is measured at the piston skirt at a right angle to the piston pin as shown in the illustration.
- The piston fitting clearance is the cylinder diameter minus the piston diameter.

PISTON FITTING CLEARANCE (S5-E) : MAX. 0.070 mm (0.0028 in.)

PISTON FITTING CLEARANCE (S5-T/S5-GS) : MAX. 0.028 mm (0.001 in.)

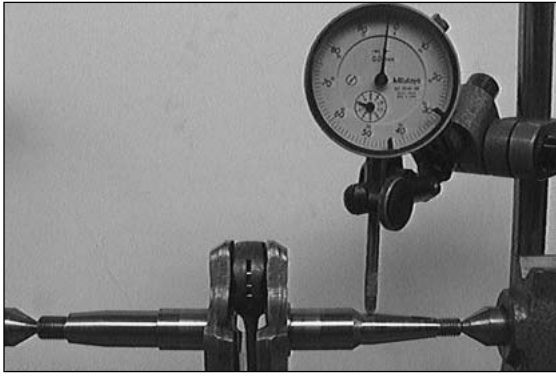

#### 4.5 Crankshaft

When intending to reuse the crankshaft, check the crankshaft journals for runout.

CRANKSHAFT JOURNAL RUNOUT: MAX. 0.05 mm (0.002 in.)

Check the radial and axial clearance of the conrod bearing.

RADIAL CLEARANCE: MAX. 0.020 mm (0.001 in.)  
 AXIAL CLEARANCE: MAX. 0.045 mm (0.0018 in.)

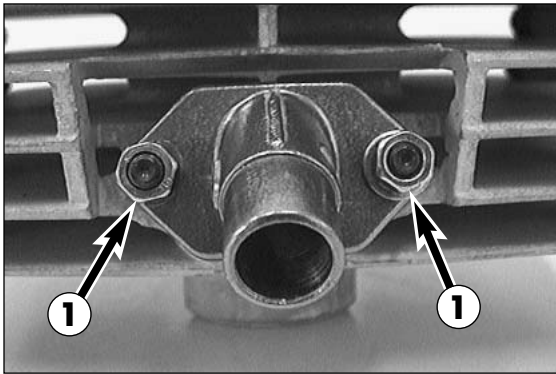

#### 4.6 Reed valve housing (S5-T)

– Release the 2 hexagon nuts ❶ and take the intake flange, the reed valve housing and the gaskets out of the cylinder.

##### REED PADDLES

Check especially the ends of the reed paddles for breakage. Reed paddles and reed valve housing should not be separated by more than a very narrow gap.

##### STOP PLATES

The distance  $M$  between the two stop plates must be 16 mm (0.65 in.) (see illustration). If necessary bend the plates to fit.

NOTE: THE REED PADDLES GRADUALLY LOOSE THEIR TENSION DURING OPERATION AND BEGIN TO BREAK AT THE ENDS, WHICH LEADS TO A REDUCED PERFORMANCE. IN THE CASE OF DAMAGE, THE ENTIRE REED VALVE HOUSING MUST BE REPLACED.

– Mount reed valve housing and intake flange with new gaskets.

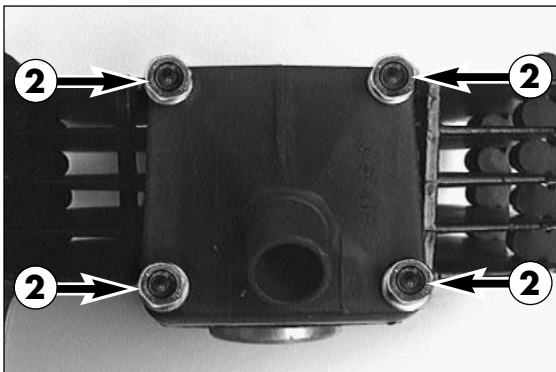
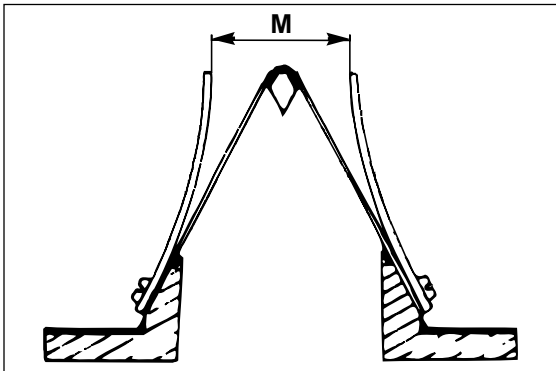

#### 4.6.1 Reed valve housing (S5-GS)

– Remove the 4 hexagon nuts ❷ and take the intake flange, the reed valve housing and the gaskets out of the cylinder.

##### REED PADDLES

Check especially the ends of the reed paddles for breakage. Reed paddles and reed valve housing should not be separated by more than a very narrow gap.

##### STOP PLATES

The distance  $M$  between the two stop plates must be 22 mm (0.9 in.) (see illustration). If necessary bend the plates to fit.

NOTE: THE REED PADDLES GRADUALLY LOOSE THEIR TENSION DURING OPERATION AND BEGIN TO BREAK AT THE ENDS, WHICH LEADS TO A REDUCED PERFORMANCE. IN THE CASE OF DAMAGE, THE ENTIRE REED VALVE HOUSING MUST BE REPLACED.

– Mount reed valve housing and intake flange with new gaskets.

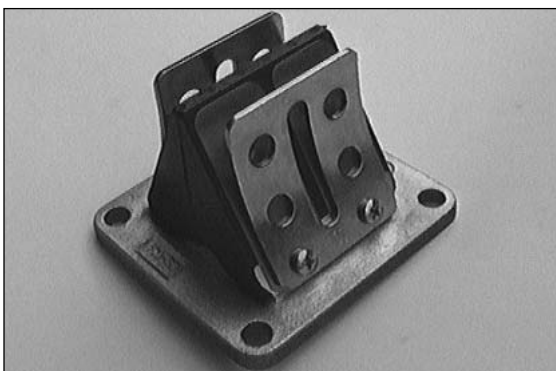

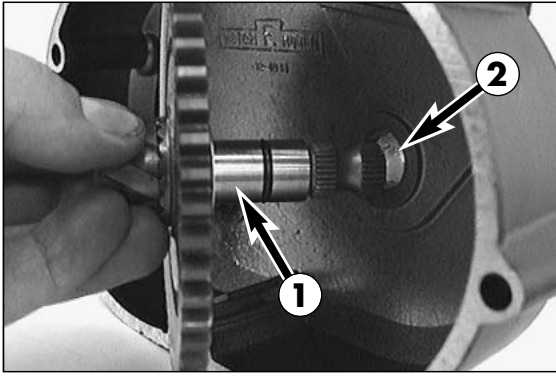

#### 4.7 Clutch cover

- Use a suitable pair of pliers to remove the circlip from the kickstarter shaft.
- Pull the ratchet gear together with the ratchet gear spring off the kickstarter shaft (kickstarter shaft must be turned from outside).
- Take the kickstarter shaft ① out of the clutch cover.

##### PIVOT POINT OF THE KICKSTARTER SHAFT ②

Check the pivot point of the kickstarter shaft in the clutch cover for grooves or signs of wear.

- Slightly grease the pivot point and insert the preassembled kickstarter shaft (see 4.8.1) into the clutch cover.

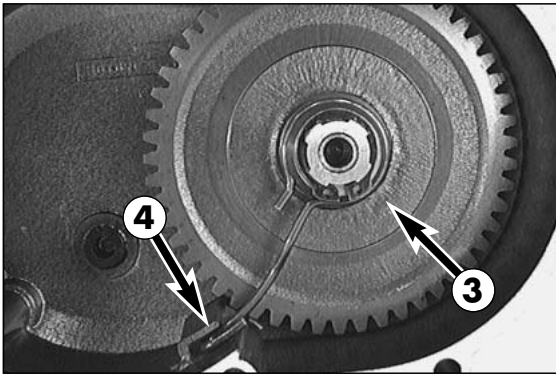

- Pull the ratchet gear ③ onto the kickstarter shaft, the teething facing the kickstarter gear, while at the same time hooking the ratchet gear spring into the opening ④ in the housing.
- Put the Seeger circlip on the kickstarter shaft with the sharp edge facing outwards.

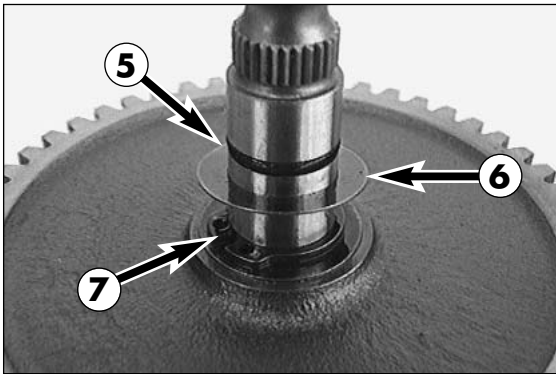

#### 4.8 Kickstarter shaft

- Take O-ring ⑤ and washer ⑥ off the kickstarter shaft.
- Take circlip ⑦, washer and kickstarter gear off the kickstarter shaft.

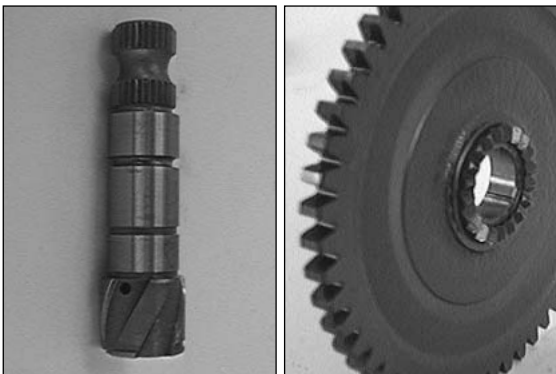

##### KICKSTARTER SHAFT

Check teeth and pivot points of the kickstarter shaft for damage or grooves caused by constant wear.

##### KICKSTARTER GEAR

Check teeth and pivot point of the kickstarter gear for damage or grooves caused by constant wear.

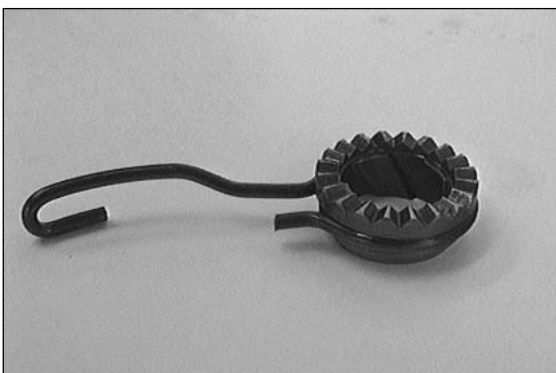

##### RATCHET GEAR

Check the teeth of the ratchet gear for signs of wear.

The ratchet gear must turn easily in the ratchet gear spring but it should not jump out of the spring eye.

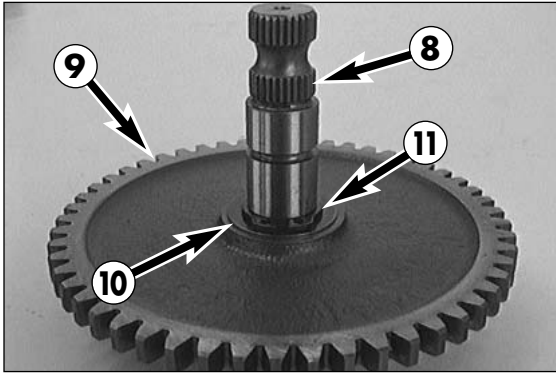

#### 4.8.1 Preassembling the kickstarter shaft

- Mount the kickstarter shaft 8 in a vise with the teeth of the ratchet gear down (use protective jaws).
- Mount the kickstarter gear 9 with the teeth for the ratchet gear showing downwards.
- Mount disk 10 and circlip 11 with the sharp edge facing up.
- Slide disk 12 onto the kickstarter shaft.
- Oil o-ring 13 and mount it into the groove of the kickstarter shaft.

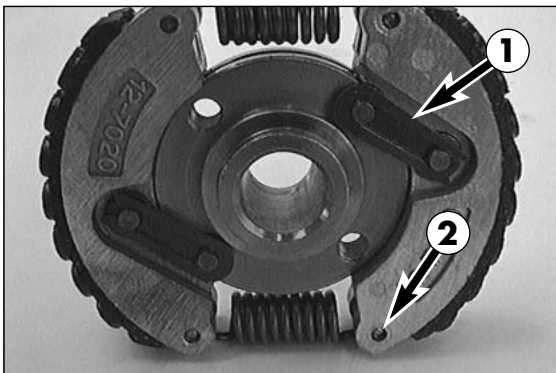
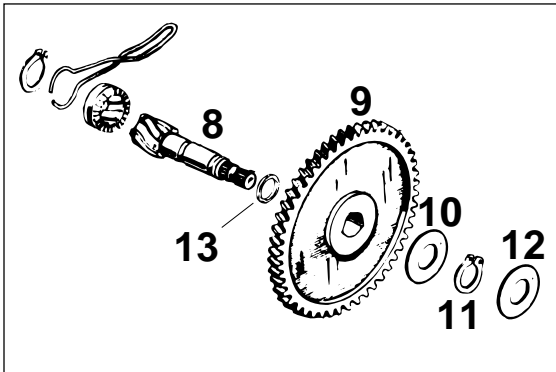

#### 4.9 Centrifugal clutch, primary drive

##### CLUTCH HUB

Check the locking devices of the chain joints 1 for tight fit.

##### CLUTCH SHOES

Check the thickness of the clutch linings. Check the clutch shoe bolts 2 for tight fit.

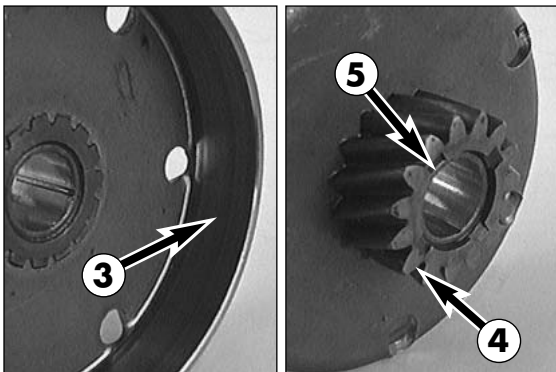

##### CLUTCH DRUM

Check the running surface 3 of the clutch drum for grooves and signs of wear.

Check the primary gear 4 for breakage and signs of wear.

Check the bronze bushing 5 for grooves and signs of wear.

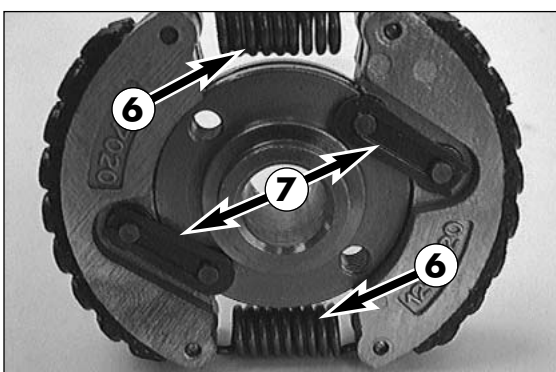

#### 4.10 Exchanging the clutch shoes

- Unhook the two clutch springs 6.
- Remove the locking devices 7 and take off both chain joints.
- Take the clutch shoes off the clutch hub.

- Slightly grease the bolts of the chain joints and use them to fix the new clutch shoes in their position.

NOTE: THE TWO LOCKING DEVICES OF THE CHAIN JOINTS MUST BE MOUNTED IN SUCH A WAY THAT THE OPEN SIDE FACES OUTWARDS.

- Hook the two clutch springs onto the bolts of the clutch shoes.

## 5.0 ASSEMBLING THE ENGINE

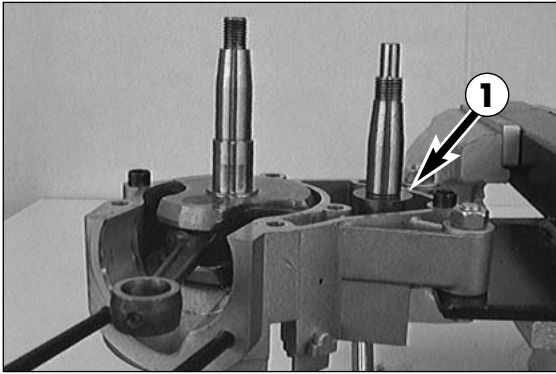

### 5.1 Mounting the crankshaft

- Place left-hand housing half in engine holder.
- Grease the shaft seal ring of the crankshaft.
- Heat the left housing half to approximately 100° C and mount the crankshaft.

**! CAUTION !**

NEVER APPLY FORCE WHEN MOUNTING THE CRANKSHAFT. AT A HOUSING TEMPERATURE OF 100° C THE CRANKSHAFT WILL SLIDE INTO THE BEARING SEAT ANYHOW, REQUIRING ALMOST NO ADDITIONAL ATTENTION.

- Insert the countershaft into the bearing seat and slide washer **1** onto the countershaft.
- Mount 2 dowel pins in the housing, position a new housing gasket and fix with a small quantity of grease.

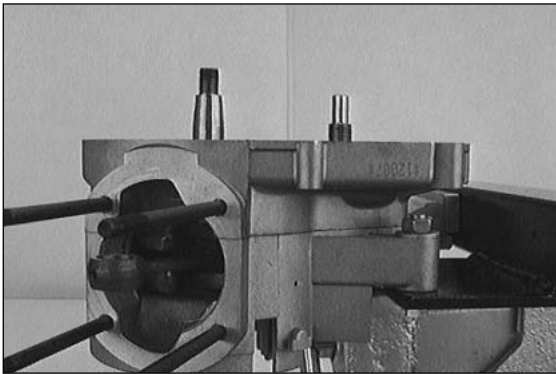

### 5.2 Assembling the housing

- Grease the shaft seal rings of the crankshaft and countershaft.
- Heat the right housing half to approximately 100° C and mount it.
- If necessary, slightly tap the right housing half with a rubber hammer.
- Grease the housing screws (thread and contact surfaces of the screw heads).
- Before and after tightening the housing screws with 8 Nm (6 ft.lb.), check both shafts for easy operation.

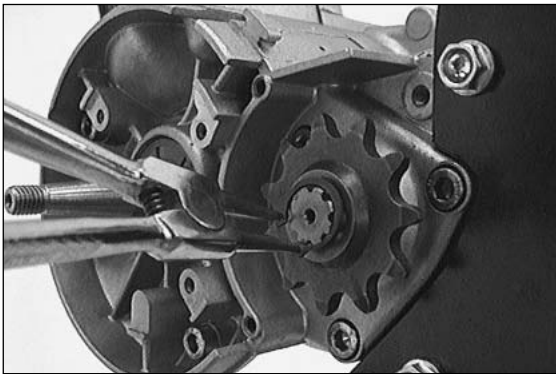

### 5.3 Engine sprocket

- Clamp the engine holder vertically into the vise.
- Slide the engine sprocket onto the countershaft.
- Mount the washer and fix the engine sprocket with the circlip (sharp edge facing outwards).

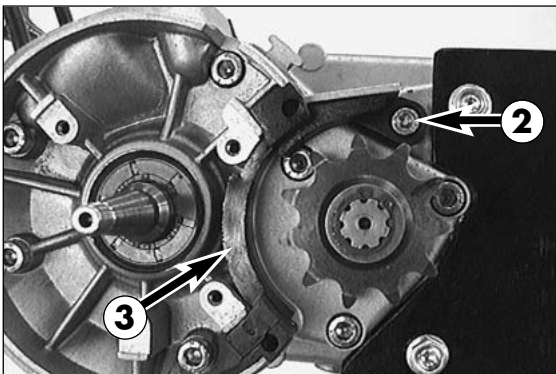

### 5.4 Chain securing guide

- Apply Loctite 242 to screw **2** and mount the chain securing guide.
- Put the rubber **3** onto the housing.

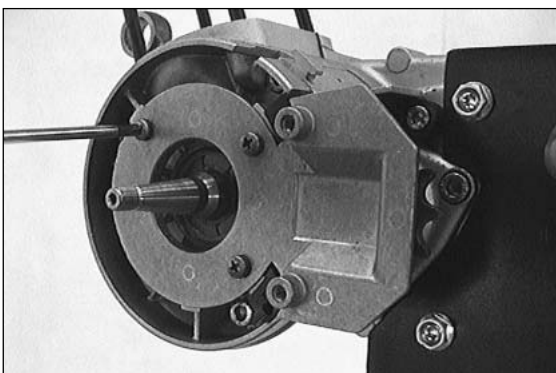

### 5.5 Mount the flywheel

- Apply Loctite 242 to the 3 screws and fix the base plate on the housing.

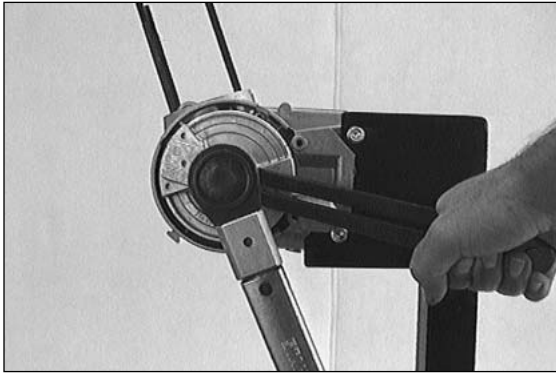

- Insert the woodruff key into the crankshaft and slide the flywheel onto the crankshaft.
- Mount washer and hexagon nut.
- Hold the flywheel with the holding wrench and tighten the hexagon nut with 30 Nm (22 ft.lb.).

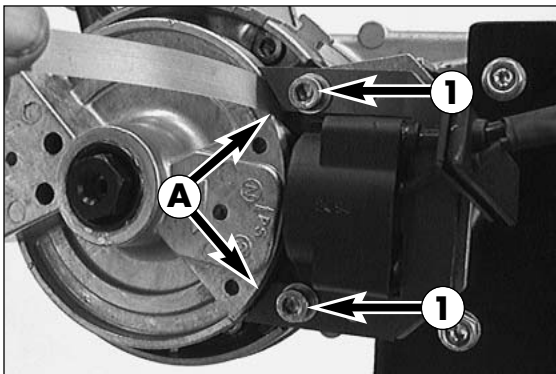

### 5.6 Mount and set the ignition coil

- Mount the ignition coil with 2 screws ❶. After tightening the screws it should still be possible to move the ignition coil sideways.
- Measure the distance between flywheel and ignition coil at points ❷ with a feeler gauge and adjust the distance.

ADMISSIBLE DISTANCE: 0.25 - 0.35 mm (0.01 - 0.015 in.)

- Tighten screws ❶ and check distance again.

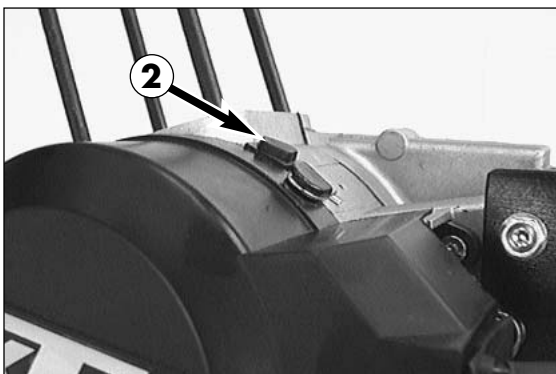
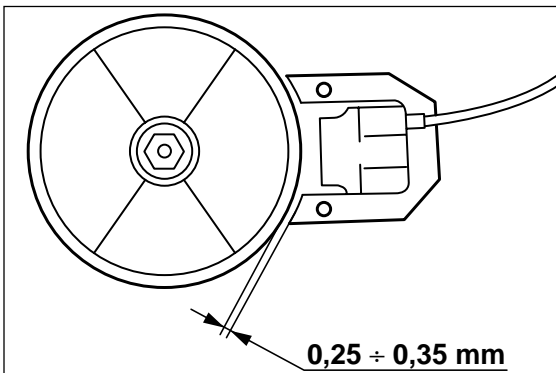

- Insert the rubber ❷ into the opening of the housing and fasten the ignition cover with the two retaining springs.



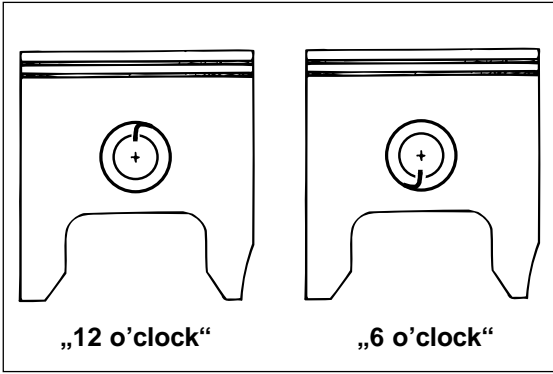

### 5.7 Piston, cylinder

- Oil the piston pin bearing and insert it into the conrod eye.
- Mount piston, piston pin and piston pin locking devices.

**! CAUTION !**

- WHEN MOUNTING THE PISTON, MAKE SURE THAT THE PISTON RING LOCKING DEVICES IN THE PISTON FACE BACKWARDS (DIRECTION OF THE INTAKE CHANNEL).
- MOUNT THE PISTON PIN LOCKING DEVICES IN A „6 O’CLOCK“ OR „12 O’CLOCK“ POSITION (SEE ILLUSTRATION).

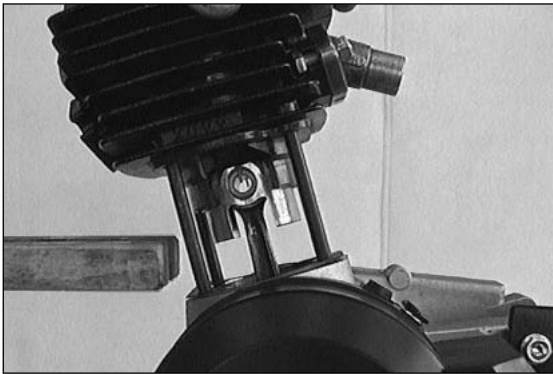

- Mount a new cylinder base gasket.
- Position the piston on the wooden fork, oil it and align the piston rings.
- Slide the cylinder over the piston and remove the wooden fork.

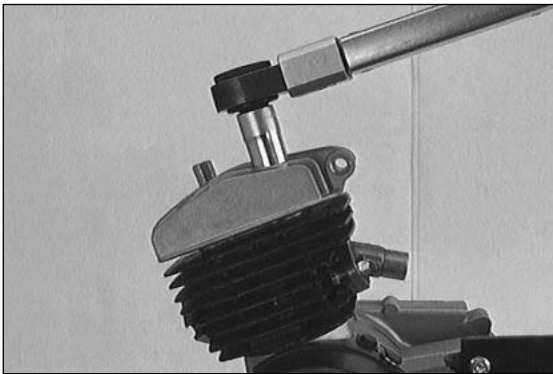

### 5.8 Cylinder head

- Put on a new cylinder head gasket and mount the cylinder head.
- Mount the 4 nuts of the cylinder head and tighten with 10 Nm (7.5 ft.lb.).
- Twist in and tighten the spark plug.

NOTE: AT THE ENGINE S5-E, THE HIGH HEXAGON NUT MUST BE MOUNTED TO THE STUD ON THE RIGHT FRONT SIDE.

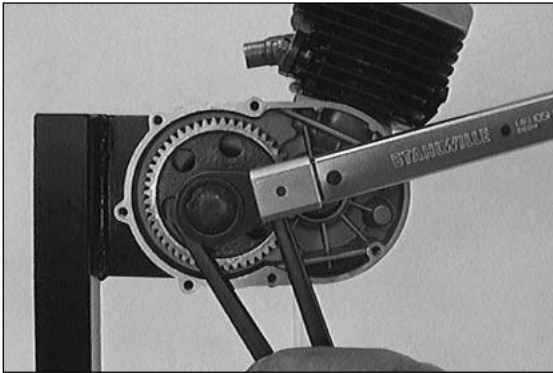

### 5.9 Primary drive, clutch

- Degrease the countershaft cone and slide the primary gear onto the countershaft.
- Mount washer and hexagon nut.
- Hold the primary gear with the holding wrench and tighten the hexagon nut with 35 Nm (25 ft.lb.).

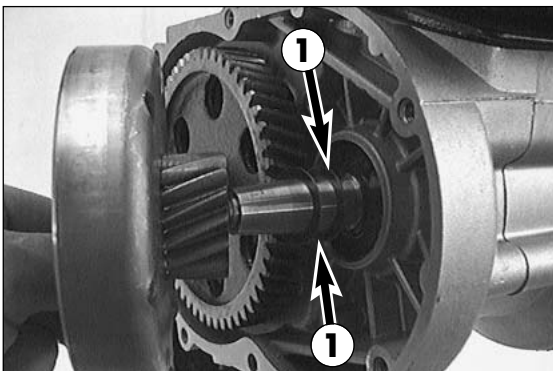

- Slide two washers ❶ onto the crankshaft.
- Oil the bushing in the clutch drum and mount the clutch drum.

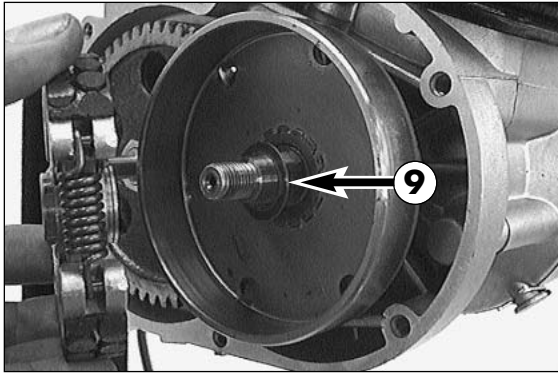

- Degrease cone and thread of the crankshaft and slide the washer ⑨ onto the crankshaft.
- Apply Loctite 242 to the crankshaft thread.

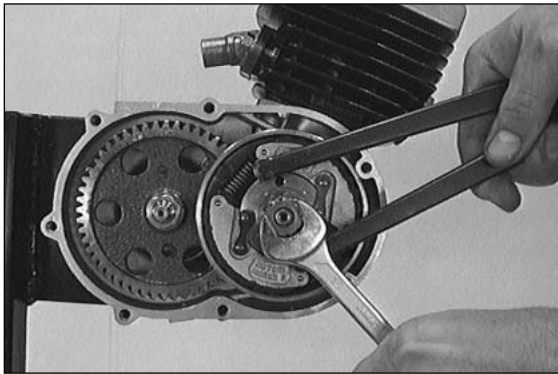

- Mount clutch hub, washer and hexagon nut.
- Hold the clutch hub with the holding wrench and tighten the nut with approximately 35 Nm (25 ft.lb.).

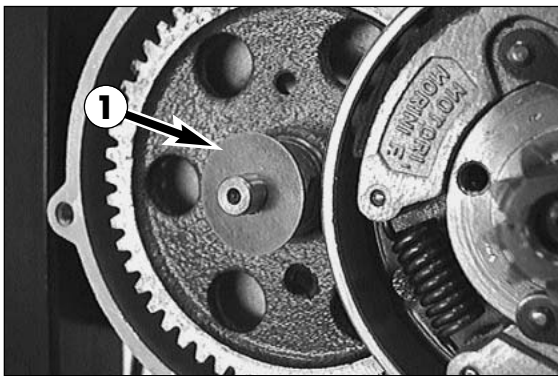

- Slide the washer ① onto the countershaft.
- Fix the new clutch cover gasket in its position with a small quantity of grease and mount the clutch cover with screws.
- Tighten the screws with 8 Nm (6 ft.lb.).

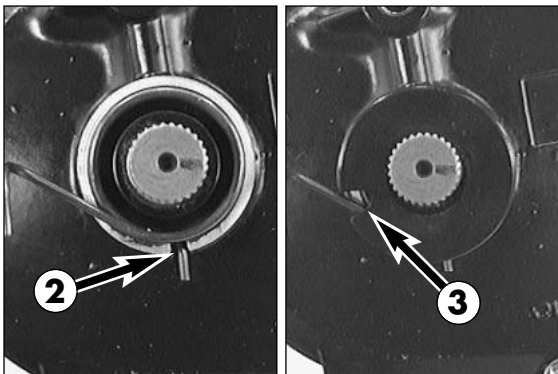

### 5.10 Kickstarter

- Slide the kickstarter spring onto the kickstarter shaft and hook the end of the kickstarter spring into the recess in the clutch cover ②.
- Mount the plastic cap in such a way that the recess ③ is located above the other end of the kickstarter spring.

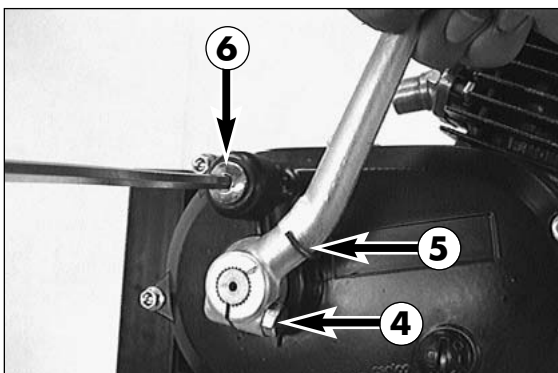

- Slide the kickstarter onto the kickstarter shaft and tighten screw ④.
- Hook the kickstarter onto the kickstarter spring ⑤ and rotate the kickstarter approximately 3/4 of a full turn clockwise. Hold the kickstarter in this position (see illustration).
- Fasten the kickstarter stop with screw ⑥ and release the kickstarter all the way to the stop.

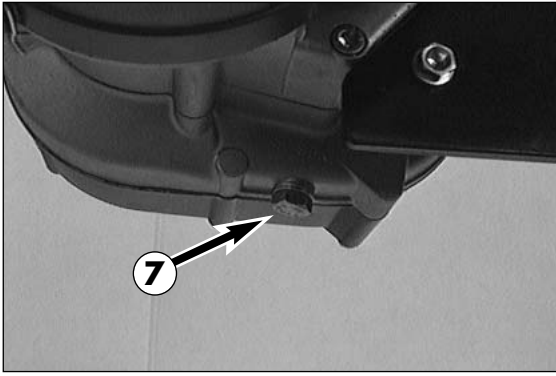

### 5.11 Gear oil

- Mount the drain plug 7 with a new seal ring and tighten with 10 Nm (7.5 ft.lb.).

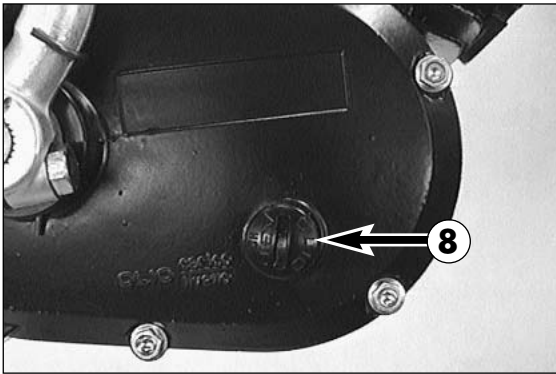

- Remove the filling plug 8 on the clutch cover and fill in 0.25 l gear oil SAE 80.

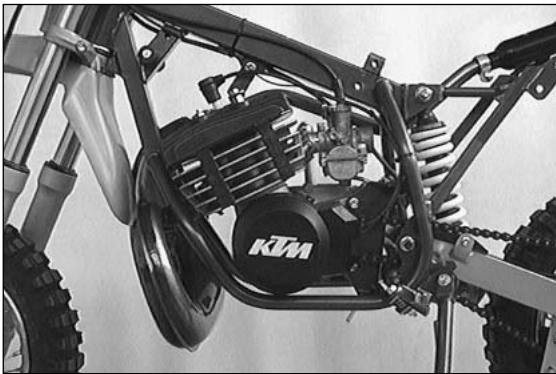

## 6.0 INSTALLING THE ENGINE

- Carry the engine into the frame.
- Mount and tighten the engine bracket screws.
- Mount carburetor.
- Mount chain and fix it with master link.
- Connect cable of short circuit button.
- Mount fuel tank, subframe and seat.
- Test ride.

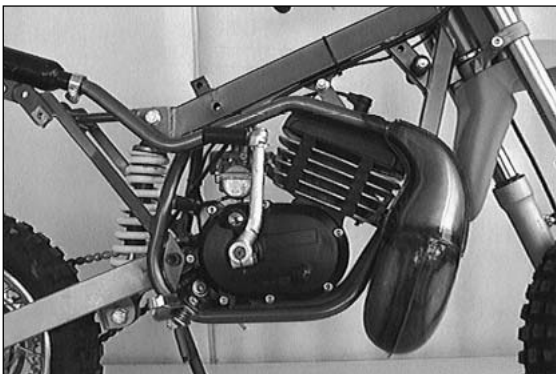

## 7.0 TECHNICAL DATA – ENGINE S5-E, S5-T, S5-GS '97

	S5-E	S5-T	S5-GS
Engine			
Design	air cooled single cylinder 2-stroke engine	air cooled single cylinder 2-stroke engine with reed valve inlet	
Displacement		49.8 cm <sup>3</sup>	
Bore/Stroke		39 / 41.7 mm	
Compression ratio		9 : 1	
Fuel		SUPER fuel, research octane no 95, mixed with 2-stroke oil	
Oil/gasoline ratio		1 : 50 when using high grade 2-stroke oil, When in doubt, please contact your importer or use 1 : 40 mix ratio to be on the safe side	
Lubrication		mixture lubrication	
Crankshaft bearing		2 grooved ball bearing	
Connecting rod bearing		needle bearing	
Piston pin bearing		needle bearing	
Piston rings		1 L-ring, 1 rectangular ring	2 rectangular ring
Primary drive	helical gears, 15 : 52 t, cast		helical gears, 15 : 52 t, milled
Rear wheel ratio		11 : 44 t	
Transmission oil		0.25 l gear oil SAE 80	
Spark plug	Bosch W 4 AC	Bosch W 7 AC	Bosch W 4 AC
Electrode gap		0.6 mm	
Carburetor	Dell'Orto SHA 14		Dell'Orto SHA 14 / Mikuni VM 18
Air filter		wet foam type air filter insert	

## 7.1 TOLERANCES AND FITTING CLEARANCES

Engine	S5-E	S5-T	S5-GS
Crankshaft	run out of crank stud max. 0.050 mm (0.002 in.)	max. 0.050 mm (0.002 in.)	max. 0.050 mm (0.002 in.)
Conrod bearing	radial play max. 0.020 mm (0.001 in.)	max. 0.020 mm (0.001 in.)	max. 0.020 mm (0.001 in.)
	axial play max. 0.045 mm (0.0018 in.)	max. 0.045 mm (0.0018 in.)	max. 0.045 mm (0.0018 in.)
Cylinder	diameter bore max. 39.026 mm (1.5368 in.)	max. 39.024 mm (1.5367 in.)	max. 39.024 mm (1.5367 in.)
Piston	fitting clearance max. 0.070 mm (0.0028 in.)	max. 0.028 mm (0.001 in.)	max. 0.028 mm (0.001 in.)
Piston ring	end gap max. 0.55 mm (0.022 in.)	max. 0.55 mm (0.022 in.)	max. 0.55 mm (0.022 in.)

## 7.2 TIGHTENING TORQUES - ENGINE

Hexagon nut primary gear	M 12x1,25	35 Nm (25 ft.lb)
Hexagon nut flywheel	M 8	30 Nm (22 ft.lb)
Nut for clutch hub	M 10	Loctite 242 + 35 Nm (25 ft.lb)
Hexagon nuts cylinder head	M 6	10 Nm (7.5 ft.lb)
Hexagon nuts exhaust pipe	M 6	8 Nm (6 ft.lb)
Oil drain plug	M 8	10 Nm (7.5 ft.lb)
Screws of housing and covers	M 6	8 Nm (6 ft.lb)
Other screws engine	M 5	5 Nm (3 ft.lb)
	M 6	8 Nm (6 ft.lb)

## 7.3 BASIC CARBURETOR SETTING

Type	Dell'Orto SHA 1412	Mikumi VM 18
Main jet	58	70
Needle jet	—	145
Idling jet	—	30
Jet needle	—	4F18-4
Needle position from top	—	IIII
Mixt. reg. screw open	—	1,5 turn
Throttle valve	—	1

8.0 PERIODIC MAINTENANCE SCHEDULE 50 SXR		KTM rider		KTM dealer	
3.97		before each start	after washing	Service after 10 hours	once a year
		Check transmission oil level			•
Change transmission oil				•	
Check spark plug and electrode gap			•		
Check carburetor for tight fit on the intake flange		•	•		
Drain and clean carburetor float chamber		•	•		
Check idle setting when engine is warm			•		
Check air filter, filter box and filter boot		•			
Check sprockets, chain guides and chain for wear		•	•		
Clean and lube chain	•	•	•		
Check chain tension	•		•		
Check exhaust system for leaks		•	•		
Check exhaust brackets		•	•		
Check brake pad thickness			•		
Check brake drums				•	
Check condition and correct instalment of brake cables	•		•		
Check freeplay and operation of hand brake levers	•		•		
Check fork for function and tightness		•	•		
Service front fork completely				•	
Check steering head bearing clearance / adjust		•	•		
Clean and grease steering head bearings and its seals			•		
Check shock absorber for function and tightness	•		•		
Check bearings of swingarm for play			•		
Clean and grease bearings of swingarm				•	
Check tightness of spokes and rim join	•		•		
Check wheel bearings for clearance		•	•		
Check tire condition and air pressure	•		•		
Check cables for damage and easy working	•		•		
Lube and adjust cables		•	•		
Check all screws, nuts and hose clamps for proper tightness	•		•		
Grease or lube all pivot points and sliding components		•	•		

KTM-SPORTMOTORCYCLE AKTIENGESELLSCHAFT  
A-5230 Mattighofen • Postfach 91 • Austria  
Internet: <http://www.ktm.co.at>  
FN 102019 d - Landesgericht Ried im Innkreis