

# KTM

# 50 SXR

Adventure '99

Pro Junior

Pro Senior

BEDIENUNGSANLEITUNG

OWNERS HANDBOOK

MANUEL D'UTILISATION

MANUAL DE INSTRUCCIONES

ART. NR.: 3.205.57

09.98





## IMPORTANT

PLEASE READ THIS MANUAL THOROUGHLY BEFORE LETTING YOUR YOUNGSTER RIDE THE MOTORCYCLE FOR THE FIRST TIME. THIS MANUAL CONTAINS IMPORTANT INFORMATION AND RECOMMENDATIONS THAT WILL HELP YOU AND YOUR YOUNGSTER TO OPERATE AND HANDLE THE MOTORCYCLE PROPERLY.

IN THE INTEREST OF EVERYBODY INVOLVED, WE URGE YOU TO PAY PARTICULAR ATTENTION TO INSTRUCTIONS AND INFORMATION MARKED AS FOLLOWS:

---

⚠ **WARNING** ⚠

---

IGNORING THESE INSTRUCTIONS, CAN ENDANGER YOUR BODY AND YOUR LIFE.

---

! **CAUTION** !

---

IGNORING THESE INSTRUCTIONS COULD CAUSE DAMAGE TO PARTS OF THE MOTORCYCLE OR THAT THE MOTORCYCLE IS NOT ROAD-SAFE ANYMORE.

Please insert below the series numbers of the motorcycle

Frame number

Engine number

Stamp of dealer

## Introduction

Now you own a modern motorcycle that you and your youngster will certainly enjoy, provided that you service and maintain it properly. This manual contains important information on the operation and maintenance of your new KTM motorcycle. It went to press describing your model's latest state of development. Nevertheless, the descriptions may deviate slightly from the current design as our motorcycles are permanently improved.

Maybe you are one of those riders who have acquired good technical skills and can perform many of the maintenance tasks themselves using the instructions contained in this manual. If this is not the case, please keep in mind that the maintenance tasks marked with an asterisk (\*) in the chapter „Maintenance of chassis and engine“ should rather be performed by a KTM dealer to protect you and your youngster.

Please strictly observe the prescribed running-in periods and inspection and maintenance intervals. Compliance with these instructions will significantly prolong the life of your motorcycle. Maintenance work should only be performed by a KTM dealer.

When special needs arise, please contact a KTM dealer, who will seek the assistance of the KTM importer if necessary.

PARENTS SHOULD KEEP IN MIND that the safety of their youngsters always depends on the efforts made by the parents to ensure that the motorcycle is kept in good working order and only used on safe terrains. Nevertheless, driving the motorcycle, like driving any other vehicle, involves a potential risk. Therefore, please make sure that all fundamental precautions are taken. Please also read the „INFORMATION ON SAFE DRIVING FOR PARENTS“ on page 4.

Riding an off-highway motorcycle is a wonderful form of outdoor recreation and we certainly hope that you and your youngsters will enjoy it to the full. However, this enjoyable outdoor activity can cause environmental problems or lead to conflicts with other people. Responsible use of the motorcycle will prevent such problems and conflicts. You can contribute to securing the future of motorcycling by making sure that you and your youngsters only use the motorcycle within the limits established by the applicable laws, making environmental protection one of your top priorities and never violating other people's rights.

In this spirit, we hope that you and your youngsters will always safely enjoy your motorcycle!



KTM Austria's certificate of achievement for its Quality System ISO 9001 is the beginning of an on-going total re-engineering quality plan for a brighter tomorrow.

KTM SPORTMOTORCYCLE AG  
5230 MATTIGHOFEN, AUSTRIA

Attachments:      1 spare parts manual chassis      1 spare parts manual engine

ALL RIGHTS RESERVED TO MAKE ALTERATIONS TO DESIGN AND MODEL.

© by KTM SPORTMOTORCYCLE AG, AUSTRIA All rights reserved

# INDEX

	Page
IMPORTANT INFORMATION ON SAFE DRIVING FOR PARENTS .....	4
SERIAL NUMBER LOCATIONS .....	5
Chassis number .....	5
Engine number, engine type.....	5
OPERATION INSTRUMENTS .....	5
Throttle grip .....	5
Right hand brake lever .....	5
Short circuit button.....	6
Left hand brake lever .....	6
Filler cap.....	6
Refueling, fuel .....	6
Fuel tap .....	7
Choke (Dell'orto carburetor SHA 1412).....	7
Choke (Mikuni carburetor VM18-144).....	7
Choke (Mikuni carburetor VM20-352).....	7
Kickstarter .....	7
DRIVING INSTRUCTIONS.....	8
What you should check before each start.....	8
Instructions for the first ride .....	8
Running in.....	8
Starting when engine is cold.....	8
Starting when engine is warm .....	9
What to do when the engine is „flooded“ .....	9
Starting off .....	9
Driving .....	9
Braking.....	9
Stopping.....	9
PERIODIC MAINTENANCE SCHEDULE .....	10
MAINTENANCE WORK ON CHASSIS AND ENGINE .....	11
Checking and adjusting the steering head bearing .....	11
Cleaning the dust scrubbers of the telescopic fork .....	11
Telescopic fork maintenance (50 SXR Adventure).....	12
Telescopic fork maintenance (50 SXR Pro JR, Pro SR).....	12
Check chain tension .....	13
Correct chain tension.....	13
Chain maintenance.....	13
Adjusting the front wheel brake cable .....	14
Checking the front brake linings for wear.....	14
Adjusting the rear wheel brake cable.....	14
Checking the rear brake linings for wear .....	14
Drum brake maintenance .....	14
Removing and mounting the front wheel.....	15
Removing and mounting the rear wheel .....	15
Tires, air pressure.....	15
Checking spoke tension.....	15
Removing the seat.....	16
Cleaning the air filter .....	16
Adjusting the throttle cable .....	16
Adjusting the idle speed .....	17
Checking the gear oil level .....	17
Changing the gear oil.....	18
Changing the seat height .....	18
TECHNICAL DATA - ENGINE.....	19
TECHNICAL DATA - CHASSIS .....	21

## IMPORTANT INFORMATION ON SAFE DRIVING FOR PARENTS



SXR mini motorcycles are off-road motorcycles designed for one person only. They are not allowed on public roads.

Motorcycle dimensions and components are designed for the following age and weight groups:

50 SXR Adventure: age 4 - 6 years, maximum weight 35 kg (78 lbs), maximum body height 130 cm (51 in)

50 SXR Pro Junior: age 4 - 6 years, maximum weight 35 kg (78 lbs), maximum body height 130 cm (51 in)

50 SXR Pro Senior: age 7 - 8 years, maximum weight 35 kg (78 lbs), maximum body height 130 cm (51 in)

- Have your youngster wear proper protective gear whenever he or she rides the motorcycle: helmet, eye protection, chest, back, arm and leg protectors, gloves and boots. To set a good example, be sure to wear protective gear yourself whenever riding a motorcycle!
- Adjust the hand brake levers to your youngster's hand size (with gloves).
- Before your youngster takes his or her first ride, explain how each of the controls works and check if your youngster has understood what you explained. We recommend to review the entire owner's manual with your youngster item by item, paying particular attention to the specially marked warnings and pointing out the danger of injury.
- Instruct your youngster about riding and falling techniques, explain how the motorcycle will respond to shifting of the rider's weight, etc.
- Before using the motorcycle you should always check all components for proper operation (see maintenance schedule). Have your youngster perform these technical checks himself / herself as well.
- Whenever you go for a ride with your youngster, keep in mind that the speed should be adjusted to your youngster and not the other way around.
- Your youngster must understand that all instructions he or she receives from you or any other supervising adult must be followed.
- Your child must be physically ready to ride a motorcycle. This means that he or she must at least be able to ride a bicycle. Being good at sports that require fast reactions is an additional advantage. Your youngster should be strong enough to pick up the motorcycle after a fall.
- Never demand too much of your youngster. Give him or her time to get used to the motorcycle and to improve his / her riding skills. Do not even consider letting your youngster participate in a race before his / her physical condition, riding skills and motivation have sufficiently developed.
- Explain to your youngster that he / she should always adjust his / her riding speed to the local conditions as well as to his / her own riding skills and that excessive speed can cause falls and severe injuries. Always keep in mind that youngsters tend to underestimate dangers or fail to recognize them altogether. The riding speed must be reduced, in particular, on unknown terrain.
- Never let your youngster ride the motorcycle without supervision. An adult should always be present.
- The motorcycle is designed for one rider only. Your youngster is not allowed to transport a passenger.
- When you go for a ride, somebody at home should always know where you are going and when you will be back. This makes it easier to send you help, should problems occur.

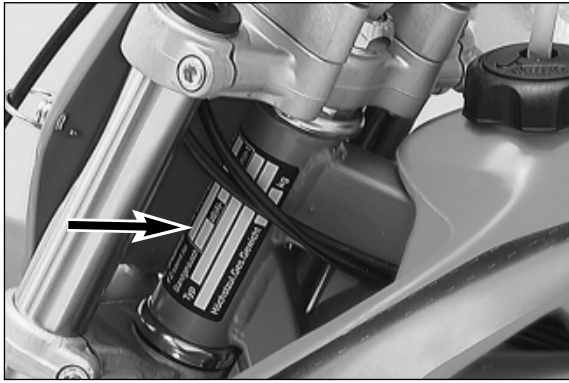

## SERIAL NUMBER LOCATIONS

### Chassis number

The chassis number is located on the type plate on the steering head. Write this number into the field on page no 1.

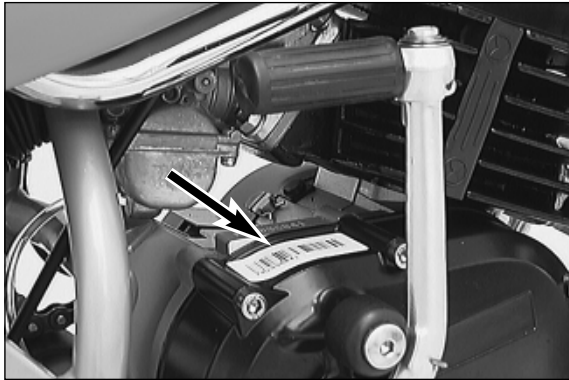

### Engine number

The engine number is stamped into the right half of the engine case next to the kickstarter. Write this number into the relevant area on page 1.

### Engine typ

Motorcycle typ	Engine typ
50 SXR Adventure.....	S5-E
50 SXR Pro Junior .....	S5-GS
50 SXR Pro Senior .....	S5-GS

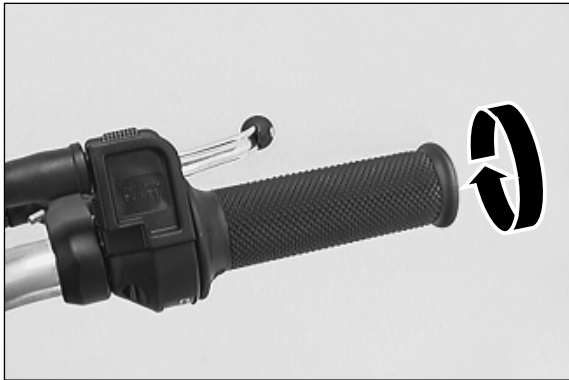

## OPERATION INSTRUMENTS

### Throttle grip

The throttle grip is located on the right side of the handlebar. It is used to reduce the engine speed and, thus, the driving speed.

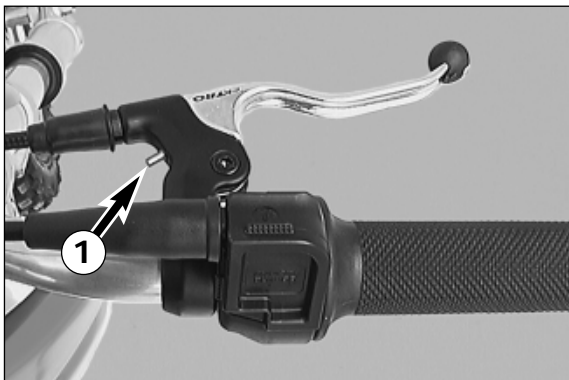

### Right hand brake lever

The right hand brake lever is used to operate the front wheel brake via a control cable.

Use stud ❶ to adjust the basic position of the hand brake lever to your youngster's hand size.

### ! CAUTION !

AFTER CHANGING THE BASIC POSITION OF THE HAND BRAKE LEVER, ALWAYS CHECK IF THE FRONT WHEEL IS TURNING EASILY. IF THIS IS NOT THE CASE, READJUST THE BRAKE CONTROL CABLE.

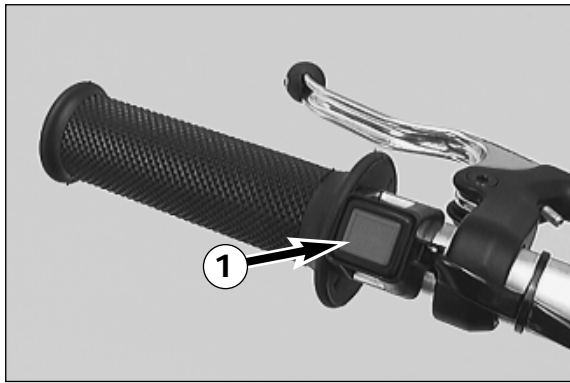

### Short circuit button

The short circuit button ❶ turns off the engine. When pressing this button, the ignition circuit is short-circuited.

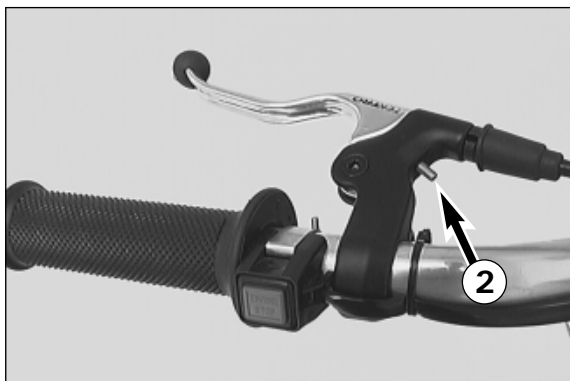

### Left hand brake lever

The left hand brake lever is used to operate the rear wheel brake via a control cable.

Use stud ❷ to adjust the basic position of the hand brake lever to your youngster's hand size.

**! CAUTION !**

AFTER CHANGING THE BASIC POSITION OF THE HAND BRAKE LEVER, ALWAYS CHECK IF THE REAR WHEEL IS TURNING EASILY. IF THIS IS NOT THE CASE, READJUST THE BRAKE CONTROL CABLE.

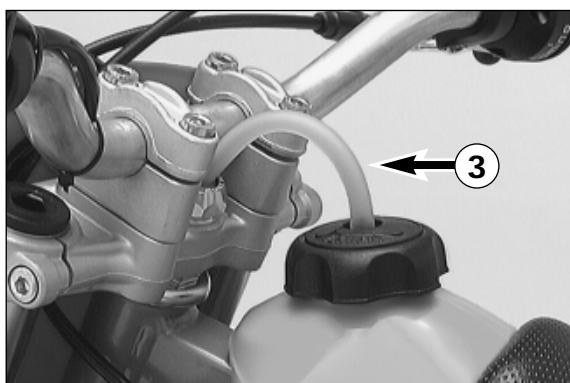

### Filler cap

To open it: turn filler cap counter-clockwise.

To close it: put filler cap back on and tighten it by turning it clockwise. Install tank breather hose ❸ without kinks.



### Refueling, fuel

Oil (high-grade two-stroke engine oil) must be mixed with the fuel (ROZ 95) at a mixing ratio of 1:40.

**⚠ WARNING ⚠**

GASOLINE IS HIGHLY FLAMMABLE AND POISONOUS. EXTREME CAUTION SHOULD BE USED WHEN HANDLING GASOLINE. NEVER REFUEL THE MOTORCYCLE NEAR OPEN FLAMES OR BURNING CIGARETTES. ALWAYS SWITCH OFF THE ENGINE BEFORE REFUELING. BE CAREFUL NOT TO SPILL GASOLINE ON THE ENGINE OR EXHAUST PIPE WHILE THE ENGINE IS HOT. WIPE UP SPILLS PROMPTLY. IF GASOLINE IS SWALLOWED OR SPLASHED IN THE EYES, SEEK A DOCTOR'S ADVICE IMMEDIATELY.

**! CAUTION !**

- ONLY USE PREMIUM-GRADE GASOLINE ROZ 95 MIXED WITH HIGH-GRADE TWO-STROKE ENGINE OIL. OTHER TYPES OF GASOLINE CAN CAUSE ENGINE FAILURE.
- ONLY USE KNOWN BRANDS OF HIGH-GRADE 2-STROKE ENGINE OIL (SHELL ADVANCE RACING X).
- NOT ENOUGH OIL OR LOW-GRADE OIL CAN CAUSE EROSION OF THE PISTON. WHEN USING TOO MUCH OIL, THE ENGINE MAY START SMOKING AND FOUL THE SPARK PLUG.
- FUEL EXPANDS WHEN ITS TEMPERATURE RISES. THEREFORE DO NOT FILL THE TANK TO THE TOP. (SEE FIG.)

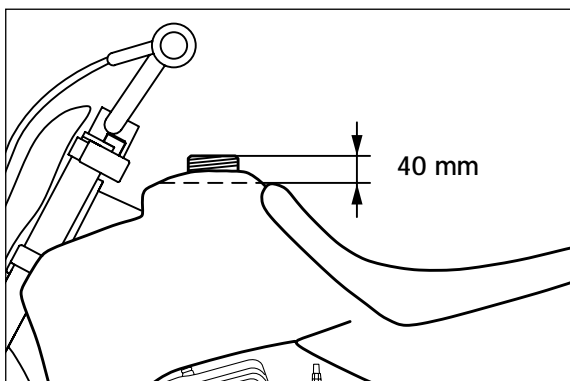



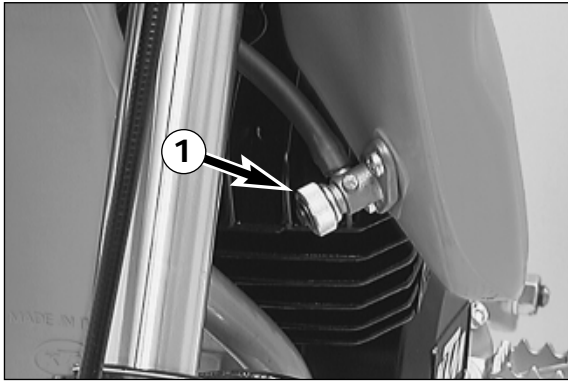

### Fuel tap

The fuel tap ❶ is located at the front of the motorcycle on the left side of the tank.

**Opening the fuel tap:** Turn the knob all the way to the left.

**Closing the fuel tap:** Turn the knob all the way to the right.

**! CAUTION !**

THE FUEL TAP SHOULD BE LOCKED WHENEVER THE MOTORCYCLE IS PARKED. IF THE TAP IS NOT CLOSED THE CARBURETOR MAY OVERFLOW AND FUEL GET INTO THE ENGINE.

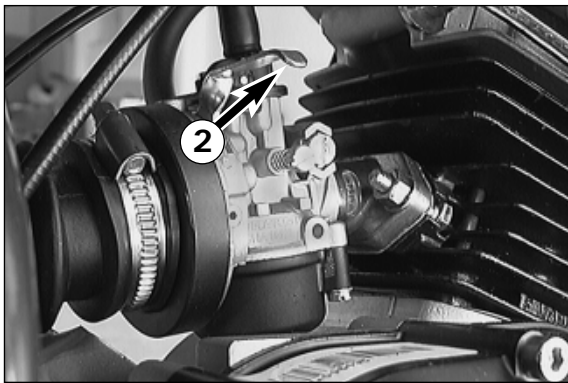

### Choke (Dell'Orto carburetor SHA 1412)

The choke lever ❷ is located on the right side of the carburetor. Squeezing and engaging the choke lever reduces the air intake of the carburetor, thus achieving the "rich" fuel air mixture needed for cold starting.

To restore the choke lever to its original position, thus deactivating the choke, briefly open the throttle all the way.

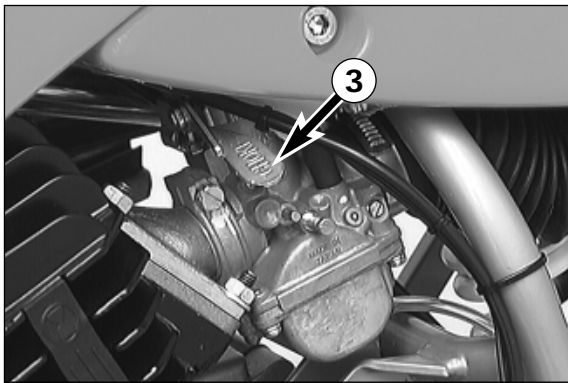

### Choke (Mikun carburetor VM18-144 / VM 16-519)

The choke lever ❸ is located on the left side of the carburetor. Squeezing the lever opens a bore in the carburetor through which the engine can take in additional fuel, thus achieving the "rich" fuel air mixture needed for cold starting.

To close the bore in the carburetor simply pull the choke lever upwards into the original position.

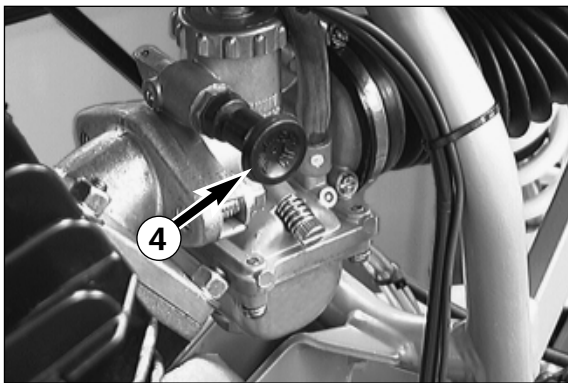

### Choke (Mikuni carburetor VM20-364)

When pulling the choke knob ❹ fully outwards, a bore is opened in the carburetor. Through this bore the engine can take in additional fuel. This ensures the rich fuel-air mixture, that is needed for a cold start.

When pressing the choke knob downward in the carburetor, the bore is closed again.

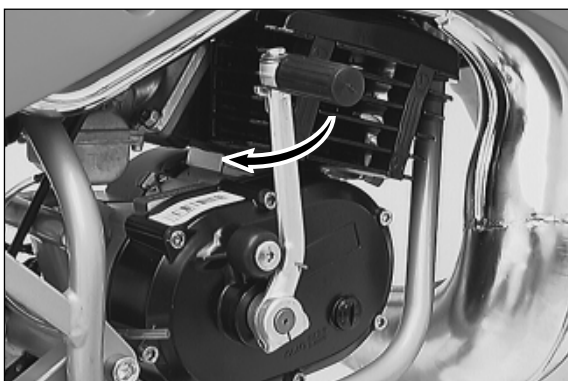

### Kickstarter

The kickstarter is mounted on the right side of the engine. Its upper part can be swivelled.

**⚠ WARNING ⚠**

WHEN STARTING THE ENGINE, PUT ON MOTORCYCLE BOOTS IN ORDER TO AVOID INJURIES. YOU MAY SLIP OFF THE KICKSTARTER, OR THE ENGINE MAY STRIKE BACK WHEN KICKING NOT VEHEMENTLY ENOUGH.



## What you should check before each start

When you start off, the motorcycle must be in a perfect technical condition. For safety reasons, you should make it a habit to perform an overall check of your motorcycle before each start.

The following checks should be performed:

- 1 CHECK TRANSMISSION OIL LEVEL.  
A lack of gear oil leads to premature wear and finally results in destruction of the gear wheels.
- 2 FUEL  
Check that there is sufficient fuel in the tank; when closing the filler cap, check that the tank venting hose is free of kinks.
- 3 CHAIN  
A loose chain may fall off the chain wheels; an extremely worn chain may tear, and insufficient lubrication may result in unnecessary wear of chain and chain wheels.
- 4 TIRES  
Check for damaged tyres. Tyres showing cuts or dents must be replaced. Also check the air pressure. Insufficient tread and incorrect air pressure deteriorate the driving performance.
- 5 BRAKES  
Check the brakes for proper adjustment and correct operation.
- 6 Throttle cable  
Check the throttle cable for proper adjustment and smooth operation.

### ⚠ WARNING ⚠

- HAVE YOUR YOUNGSTER WEAR PROPER PROTECTIVE GEAR WHENEVER HE OR SHE RIDES THE MOTORCYCLE: HELMET, EYE PROTECTION, CHEST, BACK, ARM AND LEG PROTECTORS, GLOVES AND BOOTS. TO SET A GOOD EXAMPLE, BE SURE TO WEAR PROTECTIVE GEAR YOURSELF WHENEVER RIDING A MOTORCYCLE!
- ONLY USE ACCESSORY PARTS RECOMMENDED BY KTM.

## Instructions for the first ride

- Verify that your KTM dealer performed the PREPARATION OF VEHICLE jobs (see Customer Service Manual).
- Before your youngster takes his or her first ride, explain how each of the controls works and check if your youngster has understood what you explained. We recommend to review the entire owner's manual with your youngster item by item, paying particular attention to the specially marked warnings and pointing out the danger of injury.
- Adjust the basic hand brake lever position to your youngster's hand size. Your youngster should, of course, wear gloves!
- To prevent injury, teach your youngster the basic riding skills on soft ground, e.g. on a meadow or in the garden. Be sure that there is room enough to maneuver, and that no other riders are close.
- To ensure that your youngster gets the feel of the brakes, have your youngster operate the brakes while you push the motorcycle. Do not start the engine before your youngster has learned to apply both brakes with appropriate pressure.
- Now your youngster must get the feel of the throttle. Start the engine, hold the motorcycle and have your youngster slowly open the throttle. Then, your youngster can take his/her first ride. Initially, your youngster should ride back and forth between two persons who help the young rider to stop the motorcycle. However, you should also teach your youngster how to stop the motorcycle himself/herself.

- To improve his/her riding skills, your youngster should practise to ride the motorcycle standing on the footpegs or to ride at the slowest possible speed. Additionally, you can arrange a series of obstacles and have your youngster drive around them, etc.
- Tell your youngster to look 3-10 m ahead, depending on the speed, to recognize and avoid obstacles. When riding through curves, the rider should also look far ahead into the curve.

### ⚠ WARNING ⚠

- SXR MODELS ARE DESIGNED FOR ONE PERSON ONLY. PASSENGERS ARE NOT ALLOWED.
- THESE MODELS DO NOT COMPLY WITH THE REGULATIONS AND SAFETY STANDARDS ESTABLISHED BY THE LAW. THEREFORE, THEY ARE NOT PERMITTED ON PUBLIC ROADS.
- ALWAYS KEEP IN MIND THAT OTHER PEOPLE FEEL MOLESTED BY EXCESSIVE NOISE.

## Running in

- EVEN VERY PRECISELY MACHINED SECTIONS OF ENGINE COMPONENTS HAVE ROUGHER SURFACES THAN COMPONENTS WHICH HAVE BEEN SLIDING ACROSS ONE ANOTHER FOR QUITE SOME TIME. THEREFORE, EVERY ENGINE NEEDS TO BE BROKEN IN. FOR THIS REASON, DURING ITS FIRST 5 HOURS THE ENGINE MUST NOT BE REVVED UP TO ITS PERFORMANCE LIMITS.
- APPLY LOW BUT CHANGING LOADS FOR RUNNING-IN.
- DO NOT DRIVE AT FULL LOAD FOR THE FIRST 5 HOURS!

## Starting when the engine is cold

- 1 Open fuel tap
- 2 Operate the choke
- 3 Swing the side stand all the way up.
- 4 Squeeze both brake levers.
- 5 Operate the kickstarter, depressing it all the way, without opening the throttle.

### ⚠ WARNING ⚠

- TO AVOID INJURY WHEN STARTING THE ENGINE, ALWAYS WEAR BOOTS!
- WHEN STARTING THE ENGINE, ALWAYS KEEP THE BRAKE LEVERS SQUEEZED. AS SOON AS THE ENGINE IS RUNNING, SLOWLY RELEASE THE BRAKE LEVERS. AN ACTIVATED CHOKE INCREASES THE IDLE SPEED OF THE ENGINE, THE CENTRIFUGAL CLUTCH THUS BEGINNING TO ENGAGE. THEREFORE, THE MOTORCYCLE CAN BEGIN TO MOVE WHEN THE BRAKE LEVERS ARE RELEASED.
- THE MOTORCYCLE HAS A CENTRIFUGAL CLUTCH. THE MOTORCYCLE BEGINS TO MOVE AS SOON AS THE THROTTLE IS OPENED.
- DO NOT START THE ENGINE AND ALLOW IT TO IDLE IN A CLOSED AREA. EXHAUST FUMES ARE POISONOUS AND CAN CAUSE LOSS OF CONSCIOUSNESS AND DEATH. ALWAYS PROVIDE ADEQUATE VENTILATION WHILE THE ENGINE IS RUNNING.



### Starting when the engine is warm

- 1 Open fuel tap
- 2 Swing the side stand all the way up.
- 3 Squeeze both brake levers.
- 4 Operate the kickstarter, depressing it all the way, without opening the throttle.

### What to do when the engine is „flooded“

- 1 Close fuel tap
- 2 Squeeze both brake levers.
- 3 Start engine with full throttle. If necessary, unscrew spark plug and dry it.
- 4 Once the engine is running, open fuel tap again.

### Starting off

Slowly release the brake lever while simultaneously opening the throttle.

**⚠ WARNING ⚠**

BEFORE YOU START OFF, CHECK THAT THE SIDE STAND HAS BEEN SWUNG RIGHT UP TO THE TOP. IF THE STAND DRAGS ON THE FLOOR, YOU MAY LOSE CONTROL OF YOUR MOTORCYCLE.

### Driving

The engine speed, and thus the driving speed, are regulated by the throttle grip.

The choke must always be deactivated as soon as the engine has warmed up.

If your motorcycle has a Dell'orto carburetor, briefly open the throttle all the way to restore the choke lever to its original position. If your motorcycle has a Mikuni carburetor, pull the choke lever upwards into the original position.

**⚠ WARNING ⚠**

- YOUR CHILD SHOULD NEVER DRIVE FASTER THAN ITS SKILLS AND THE TERRAIN PERMIT.
- NEVER LET YOUR CHILD DRIVE ITS MOTORCYCLE UNCHAPERONED.
- WHEN THE ENGINE SPEED DROPS TO THE LEVEL AT WHICH THE CENTRIFUGAL CLUTCH DISENGAGES, BRAKING WITH THE ENGINE IS NO LONGER POSSIBLE AND THE MOTORCYCLE CAN ONLY BE SLOWED DOWN USING THE BRAKES.
- REPLACE THE HELMET VISOR OR GOGGLE GLASSES EARLY ENOUGH. WHEN LIGHT SHINES DIRECTLY ON A SCRATCHED VISOR OR GOGGLES, YOU WILL BE PRACTICALLY BLIND.
- AFTER FALLING WITH THE MOTORCYCLE, CHECK ALL ITS FUNCTIONS THOROUGHLY BEFORE USING IT AGAIN.

**! CAUTION !**

- DRIVING A COLD ENGINE AT HIGH SPEED WILL REDUCE THE LIFE OF THE ENGINE. WE RECOMMEND TO WARM THE ENGINE UP AT A MEDIUM ENGINE SPEED FOR SEVERAL MINUTES BEFORE SWITCHING TO FULL LOAD.
- WHILE YOU ALLOW THE ENGINE TO WARM UP, NEVER LET YOUR MOTORCYCLE REST ON ITS SIDESTAND IN AN INCLINED POSITION (SEE PHOTO). THIS INCLINED POSITION MIGHT CAUSE ENGINE FAILURE.
- IN THE EVENT THAT, WHILE YOUR CHILD IS RIDING ON THE MOTORCYCLE, YOU NOTICE ANY UNUSUAL OPERATION-RELATED NOISE, YOUR CHILD SHOULD STOP IMMEDIATELY, TURN THE ENGINE OFF, AND CONTACT AN AUTHORIZED KTM DEALER.

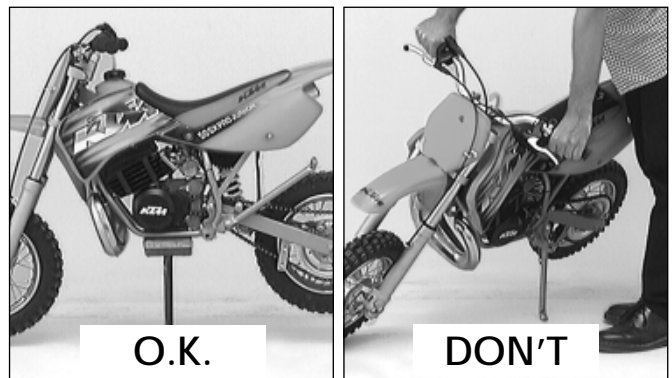

### Braking

Close the throttle and squeeze both brake levers simultaneously. On sandy, wet or slippery terrain the rear wheel brake should be preferred. The brakes should always be operated carefully as locking wheels can cause skidding or falls.

**⚠ WARNING ⚠**

BRAKE DRUM AND LININGS HEAT UP DURING BRAKE OPERATION, THUS REDUCING THE EFFECT OF THE BRAKES.

### Stopping

Reduce the speed. Immediately before the motorcycle comes to a stop, put the left foot down. To turn off the engine, press the short circuit button until the engine stops. Close the fuel tap.

**⚠ WARNING ⚠**

- NEVER LEAVE YOUR MOTORCYCLE WITHOUT SUPERVISION AS LONG AS THE ENGINE IS RUNNING.
- MOTORCYCLES PRODUCE GREAT HEAT DURING OPERATION. THEREFORE, KEEP IN MIND THAT THE ENGINE, THE EXHAUST SYSTEM AND THE BRAKES CAN HEAT UP CONSIDERABLY. MAKE SURE THAT THESE PARTS ARE NOT TOUCHED AND ALWAYS TAKE CARE, WHEN PARKING THE MOTORCYCLE, THAT OTHER PERSONS WILL NOT BURN THEMSELVES.

**! CAUTION !**

CLOSE THE FUEL TAP WHEN LEAVING THE MOTORCYCLE. OTHERWISE THE CARBURETOR MAY GET FLOODED AND FUEL WILL ENTER THE ENGINE.

# PERIODIC MAINTENANCE SCHEDULE 50 SXR

09.98



KTM rider

KTM dealer

before each start

after washing

Service after 10 hours

once a year

	before each start	after washing	Service after 10 hours	once a year
Check transmission oil level			•	
Change transmission oil				•
Check spark plug and electrode gap			•	
Check carburetor for tight fit on the intake flange		•	•	
Drain and clean carburetor float chamber		•	•	
Check idle setting when engine is warm			•	
Check air filter, filter box and filter boot		•		
Check sprockets, chain guides and chain for wear		•	•	
Clean and lube chain	•	•	•	
Check chain tension	•		•	
Check exhaust system for leaks		•	•	
Check exhaust brackets		•	•	
Check brake lining thickness			•	
Check brake drums			•	
Check freeplay and operation of hand brake levers	•		•	
Check fork for function and tightness		•	•	
Service front fork completely				•
Check steering head bearing clearance / adjust		•	•	
Clean and grease steering head bearings			•	
Check shock absorber for function and tightness	•		•	
Check bearings of swingarm for play			•	
Clean and grease bearings of swingarm				•
Check tightness of spokes and rim join	•		•	
Check wheel bearings for clearance		•	•	
Check tire condition and air pressure	•		•	
Check cables for damage, correct instalment and easy working	•		•	
Lube and adjust cables		•	•	
Check all screws, nuts and hose clamps for proper tightness	•		•	
Grease or lube all pivot points and sliding components		•	•	

# MAINTENANCE WORK ON CHASSIS AND ENGINE



## WARNING



MAINTENANCE WORK AND ADJUSTMENTS MARKED WITH AN ASTERISK (\*) MUST BE PERFORMED BY AN EXPERT. TO PROTECT YOUR YOUNGSTER, ALWAYS HAVE SUCH WORK PERFORMED BY A SPECIALIZED KTM DEALER.



## CAUTION



- WHEN CLEANING THE MOTORCYCLE, DO NOT USE A HIGH PRESSURE CLEANING UNIT IF POSSIBLE, OTHERWISE WATER WILL PENETRATE THE BEARINGS, CARBURETOR, ELECTRIC CONNECTORS ETC.
- WHEN TRANSPORTING YOUR MOTORCYCLE, SECURE IT WITH ELASTIC STRAPS OR OTHER MECHANICAL DEVICES IN AN UPRIGHT POSITION. BE SURE THAT THE FUEL TAP IS CLOSED. IF THE MOTORCYCLE TOPPLES OVER, FUEL CAN FLOW OUT OF THE CARBURETOR OR FUEL TANK.
- DO NOT USE TOOTHED WASHERS OR SPRING RINGS WITH THE ENGINE FASTENING SCREWS, AS THESE WORK INTO THE FRAME PARTS AND KEEP WORKING LOOSE. INSTEAD, USE SELF-LOCKING NUTS.
- LET YOUR MOTORCYCLE COOL DOWN BEFORE BEGINNING ANY MAINTENANCE WORK IN ORDER TO AVOID GETTING BURNED.
- REMOVE OILS, FATTY MATTERS, FILTERS, FUELS, WASHING DETERGENTS ETC. ORDERLY.
- UNDER NO CIRCUMSTANCES MAY USED OIL BE DISPOSED OF IN THE SEWAGE SYSTEM OR IN THE OPEN COUNTRYSIZE. 1 LITER USED OIL CONTAMINATES 1.000.000 LITERS WATER.

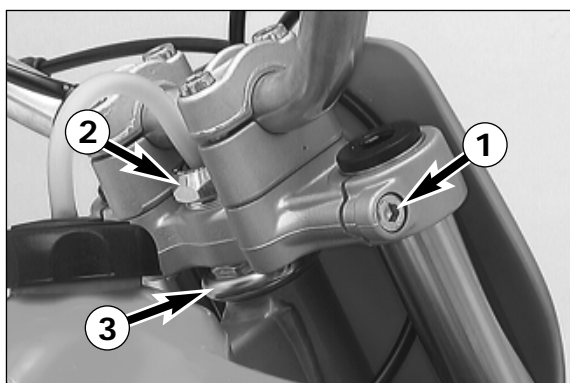

### Checking and adjusting the steering head bearing \*

The steering head bearing should regularly be checked for play. For this purpose, jack up the motorcycle by the frame so that the front wheel is in the air. Now try to move the fork forward and backward. There should be no play. For readjustment, release the two clamp screws ① of the top triple clamp and the counter nut ②. Turn the adjusting nut ③ until almost no play is left. Do not tighten the adjusting nut! Tightening the adjusting nut can damage the bearings! Keep in mind that tightening the counter nut ② reduces the play of the bearing. Slightly tap the top triple clamp with a rubber hammer to prevent jamming. Then tighten the 2 clamp screws with 15 Nm (11 ft.lb).



## WARNING



IF THE STEERING HEAD BEARING IS NOT ADJUSTED TO BE FREE OF PLAY, THE MOTORCYCLE WILL EXHIBIT UNSTEADY DRIVING CHARACTERISTICS AND CAN GET OUT OF CONTROL.



## CAUTION



- THE HANDLEBAR MUST MOVE EASILY. OTHERWISE THE BEARINGS WILL BE DAMAGED.
- IF YOU DRIVE WITH PLAY IN THE STEERING HEAD BEARING FOR LONGER PERIODS, THE BEARINGS AND SUBSEQUENTLY THE BEARING SEATS IN THE FRAME WILL BE DESTROYED.

At least once a year, the steering head bearings should be smeared with waterproof grease.

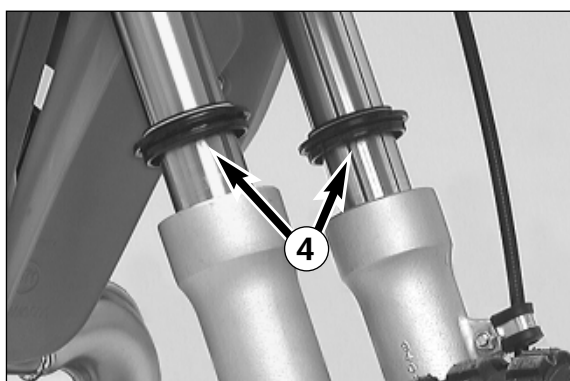
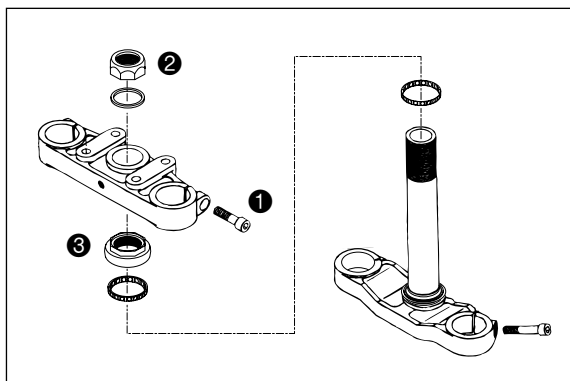

### Cleaning the dust scrabbers of the telescopic fork

The dust scrabbers ④ should be cleaned on a regular basis. For this purpose, use a screwdriver to lever the dust scrabbers out of the slider tubes, clean them thoroughly with compressed air, spray the fork tubes and dust scrabbers with silicon oil and press the scrabbers back into the slider tubes.

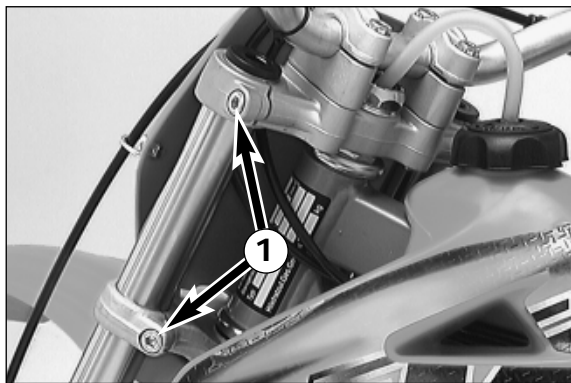

### Telescopic fork maintenance (50 SXR Adventure) \*

The telescopic fork must be serviced at least once a year:

- Jack up the motorcycle by the frame to take the weight off the front wheel.
- Remove the front wheel and the brake cable guide.
- Release the clamp screws **1** at the triple clamps and pull the fork legs downwards out of the triple clamps.

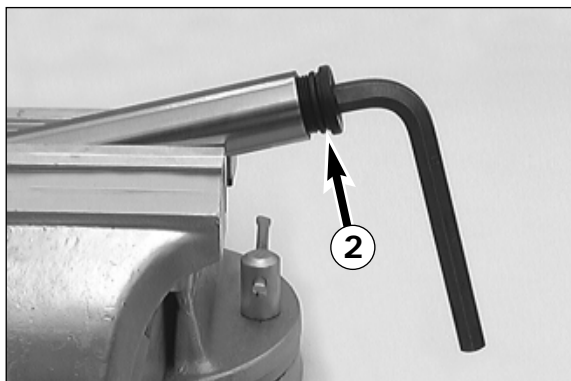

- Clamp the fork leg into a vise (use protective jaws) and remove the plugs **2**.
- Take the preload spacer and the spring out of the fork tube.
- Remove screws **3** at the underside of the slider tubes and pull the fork tubes out of the slider tubes.
- Remove the dust scrubbers **4**.

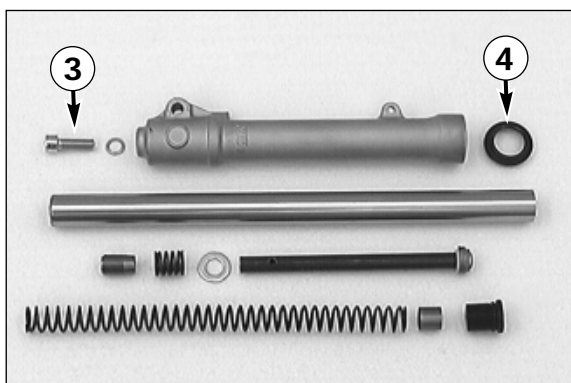

- Thoroughly clean all parts and check for wear.
- Grease gaskets and springs and reassemble the telescopic fork.
- Tighten the screws at the underside of the slider tubes with 30 Nm (22 ft.lb).
- Insert the fork legs into the triple clamps (the fork tube must be flush with the top triple clamp) and tighten the clamp screws with 15 Nm (11 ft.lb).
- Mount the front wheel.



### Changing the telescopic fork oil (50 SXR Pro JR, Pro SR) \*

- Remove front wheel and fork legs (see above).
- Remove plugs, preload spacers and springs.
- Drain the fork oil into an appropriate container.
- Clean the dust scrubbers.



- Fill the fork tubes with new fork oil (SAE 7.5)  
 Pro JR: 150 ccm per fork tube  
 Pro SR: 160 ccm per fork tube
- Insert springs and preload spacers into the fork tube.
- Check and grease O-rings and mount the plugs.
- Mount fork legs and front wheel (see above), then mount the cable guide.

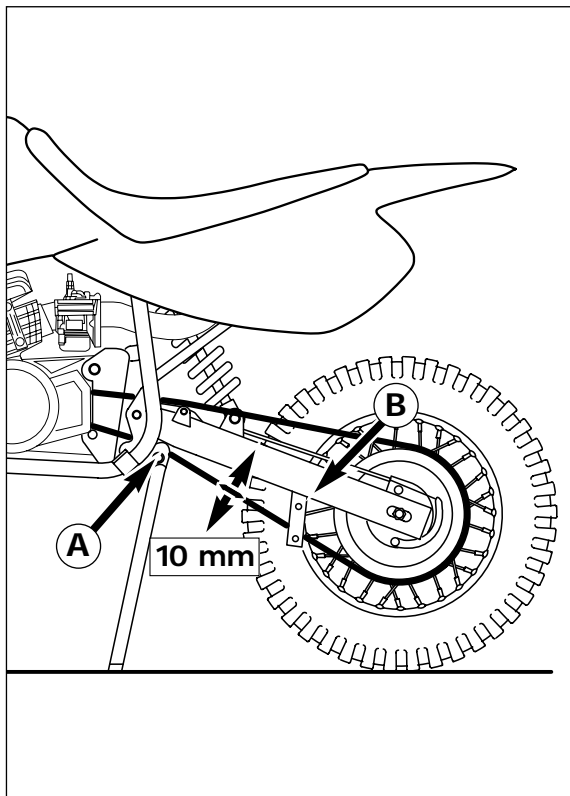

### Check chain tension

- Put the motorcycle on the sidestand.
- Check the chain tension approximately in the middle between the two chain guides **A** and **B**. In this area, the chain should easily move approximately 10 mm (0.4 in) upward and downward.
- If necessary, correct chain tension.

⚠ **WARNING** ⚠

- If CHAIN TENSION IS TOO GREAT, PARTS WITHIN THE SECONDARY TRANSMISSION (CHAIN, CHAIN WHEELS, GEAR BOX AND REAR WHEEL BEARINGS) WILL BE SUBJECTED TO UNNECESSARY STRESS, RESULTING IN PREMATURE WEAR AND EVEN CHAIN BREAKAGE.
- TOO MUCH SLACK IN THE CHAIN, ON THE OTHER HAND, CAN RESULT IN THE CHAIN JUMPING OFF THE CHAIN WHEELS. IF THIS HAPPENS, THE CHAIN COULD ALSO BLOCK THE REAR WHEEL OR DAMAGE THE ENGINE.
- IN EITHER CASE THE OPERATOR IS LIKELY TO LOSE CONTROL OF THE MOTORCYCLE.

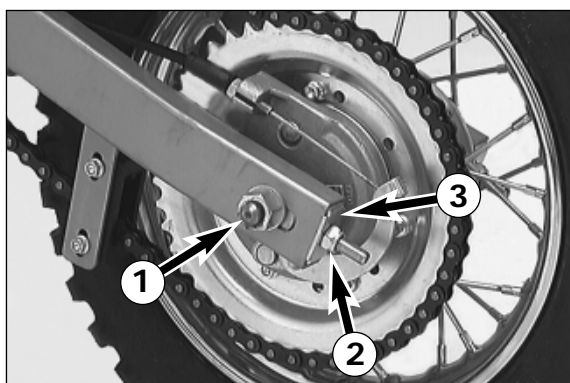

### Correct chain tension

- Release the hexagon nut of the wheel spindle **1** and turn the left and the right hexagon nut **2** equally far.
- Before tightening the hexagon nut of the wheel spindle with 30 Nm (22 ft.lb), ensure that the supporting plates **3** are resting against the swing arm. Additionally, check that the rear wheel is aligned with the front wheel.

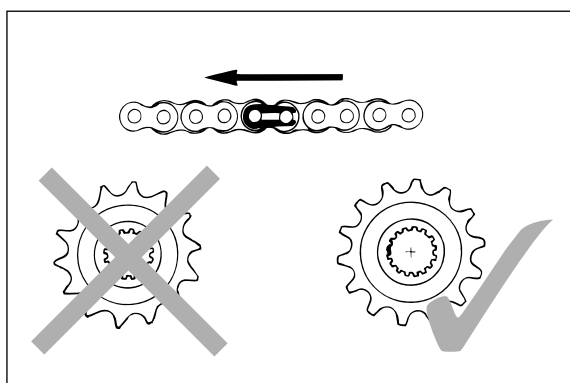
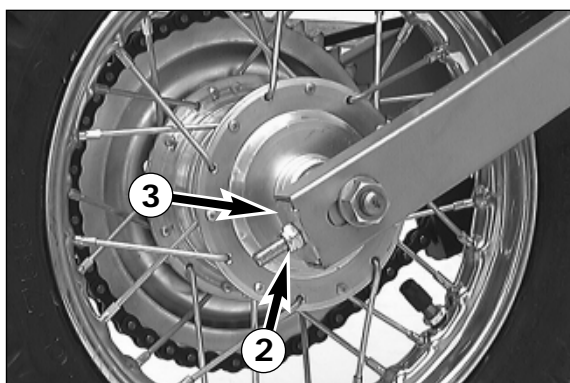

### Chain maintenance

For long chain life, good maintenance is very important. Chains without O-rings should be cleaned in fireproof solvent regularly and afterwards treated with hot grease or chain spray (Shell Advance Bio Chain).

⚠ **WARNING** ⚠

KEEP THE REAR WHEEL FREE OF GREASE! GREASE ON THE REAR WHEEL WILL SIGNIFICANTLY REDUCE THE GRIP OF THE REAR TIRE AND THE MOTORCYCLE COULD EASILY GET OUT OF CONTROL.

! **CAUTION** !

WHEN MOUNTING THE CHAIN MASTERLINK CLIP, THE CLOSED SIDE OF THE MASTERLINK CLIP MUST POINT IN RUNNING DIRECTION.

Also check sprockets and chain guides for wear, and replace if necessary.

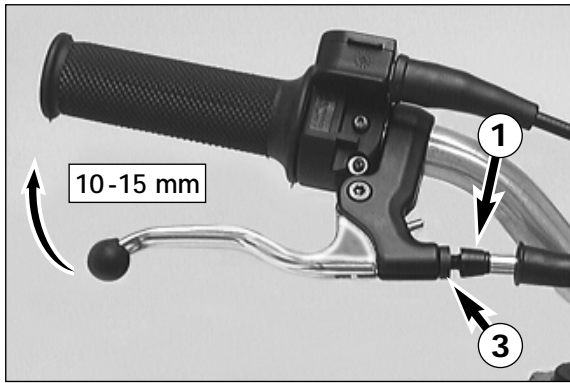

### Adjusting the front wheel brake cable

The hand brake lever should travel between 10 and 15 mm (0.4-0.6 in) before the front wheel is actually slowed down.

To adjust the brake control cable, use either the adjusting screw ① at the hand brake lever or the adjusting screw ② at the brake backing plate. Before commencing to adjust the cable, always release the counter nut ③. Afterwards, the counter nut must be retightened.

! CAUTION !

AFTER ADJUSTING THE CABLE, ALWAYS CHECK IF THE WHEEL TURNS SMOOTHLY.

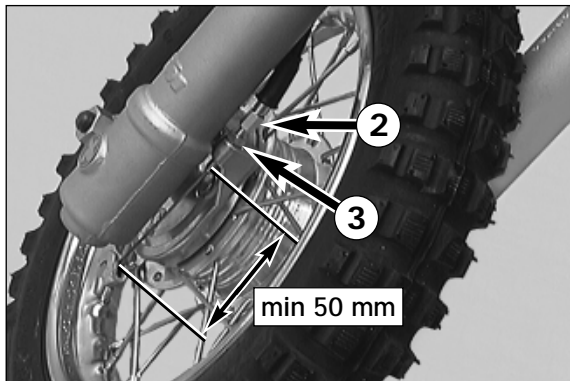

### Checking the front brake linings for wear

The brake linings must be replaced when the distance between the hub brake lever and the cable support, measured with the brake lever squeezed, is less than 50 mm (2 in) (see illustration).

! CAUTION !

IF THE BRAKE LININGS ARE REPLACED TOO LATE, I.E. WHEN THE LINING IS PARTLY OR FULLY WORN AWAY, THE METAL SHOES WILL RUB AGAINST THE BRAKE DRUM, THUS REDUCING THE BRAKING EFFECT AND DESTROYING THE BRAKE DRUM.

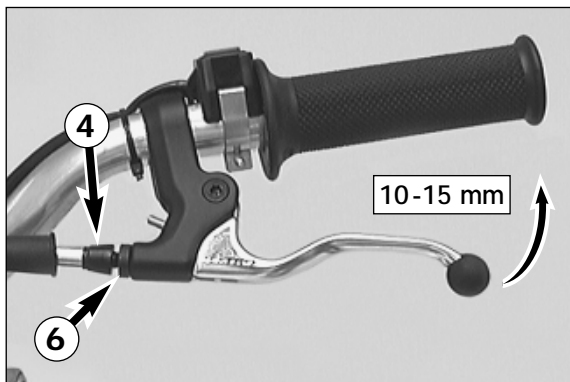

### Adjusting the rear wheel brake cable

The hand brake lever should travel between 10 and 15 mm (0.4-0.6 in) before the rear wheel is actually slowed down.

To adjust the brake control cable, use either the adjusting screw ④ at the hand brake lever or the adjusting screw ⑤ at the brake backing plate. Before commencing to adjust the cable, always release the counter nut ⑥. Afterwards, the counter nut must be retightened.

! CAUTION !

AFTER ADJUSTING THE CABLE, ALWAYS CHECK IF THE WHEEL TURNS SMOOTHLY.

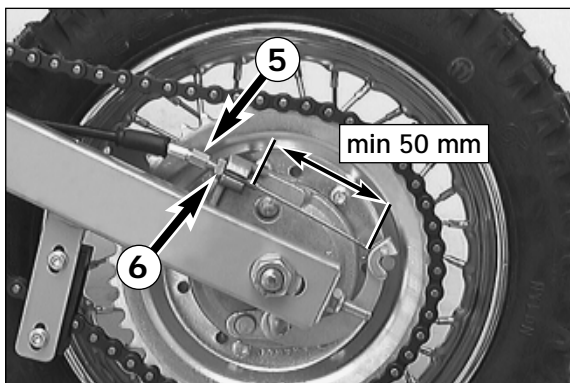

### Checking the rear brake linings for wear

The brake linings must be replaced when the distance between the hub brake lever and the cable support, measured with the brake lever squeezed, is less than 50 mm (2 in) (see illustration).

! CAUTION !

IF THE BRAKE LININGS ARE REPLACED TOO LATE, I.E. WHEN THE LINING IS PARTLY OR FULLY WORN AWAY, THE METAL SHOES WILL RUB AGAINST THE BRAKE DRUM, THUS REDUCING THE BRAKING EFFECT AND DESTROYING THE BRAKE DRUM.

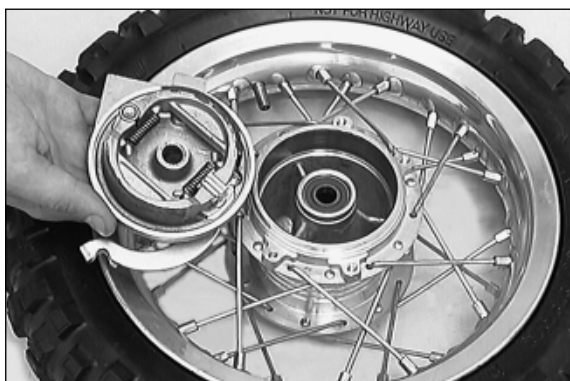

### Drum brake maintenance

Drum brake maintenance is limited to occasional blowing out of brake drum and brake shoes. Brake drum and brake linings can be slightly roughened with an abrasive cloth.



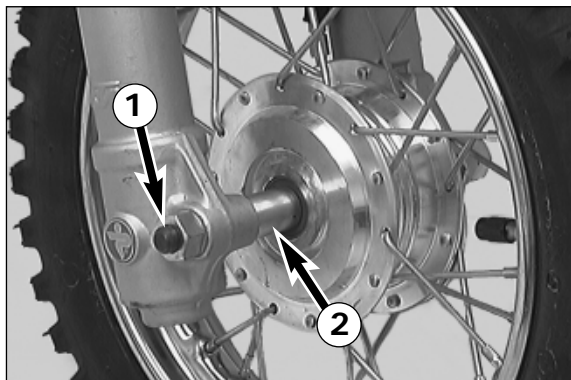

### Removing and mounting the front wheel

- Jack up the motorcycle by the frame.
  - Remove the right hexagon nut of the wheel spindle ❶ together with the washer.
  - Pull the wheel spindle halfway out and remove the spacer ❷.
  - Now pull out the wheel spindle out until the wheel is free but not so far that the brake backing plate comes off.
  - Turn both wheel and fork slider tube to the left and remove wheel.
- To mount the wheel reverse the procedure described above.
- Tighten the hexagon nut with 30 Nm (22 ft.lb).

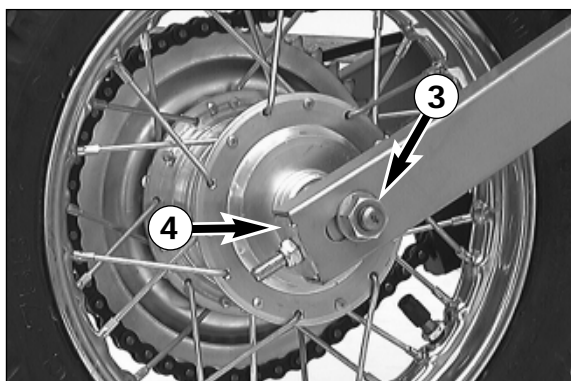

### Removing and mounting the rear wheel

- Jack up the motorcycle by the frame.
- Remove the right hexagon nut of the wheel spindle ❸ together with the washer.
- Hold the rear wheel and remove the wheel spindle.
- Move the rear wheel downward, remove the chain and take the rear wheel out of the swing arm.

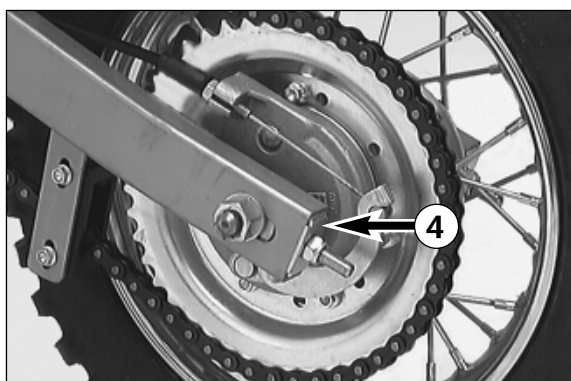

- To mount the wheel reverse the procedure described above.
- Always hook the brake backing plate into the swing arm support.
- Before tightening the hexagon nut of the wheel spindle, ensure that the supporting plates ❹ are resting against the swing arm. Additionally, check that the rear wheel is aligned with the front wheel.
- Tighten the hexagon nut with 30 Nm (22 ft.lb).



### Tires, air pressure

Tire type, tire condition, and air pressure level affect the way your motorcycle rides, and they must therefore be checked whenever you are getting ready to go anywhere on your motorcycle.

- Tire size can be found in the technical specifications.
- Tire condition has to be checked every time you want to ride your motorcycle. Before leaving, check tires for punctures and nails or other sharp objects that might have become embedded in them.
- Regularly check the "cold" tire pressure. Correct tire pressure (1.0 bar / 14 psi) guarantees optimum grip and maximum tire life.



#### WARNING



- DAMAGED TIRES MUST BE REPLACED IMMEDIATELY TO PROTECT YOUR YOUNGSTER.
- WORN TIRES CAN HAVE A NEGATIVE EFFECT ON HOW THE MOTORCYCLE PERFORMS, ESPECIALLY ON WET SURFACES
- TIRE PRESSURE BELOW THE NORMAL LEVEL WILL LEAD TO PREMATURE TIRE WEAR.



### Checking spoke tension

The correct spoke tension is very important for the stability of the wheels and thus for riding safety. A loose spoke causes the wheel to become unbalanced and before long other spokes will have come loose. Check spoke tension, especially on a new motorcycle, in regular intervals. If necessary, have the spokes retightened and the wheel centered by a KTM dealer.



#### WARNING



SPOKES CAN TEAR IF YOU CONTINUE TO RIDE WITH THEM LOOSE. THIS MAY LEAD TO AN UNSTABLE HANDLING OF YOUR MOTORCYCLE.

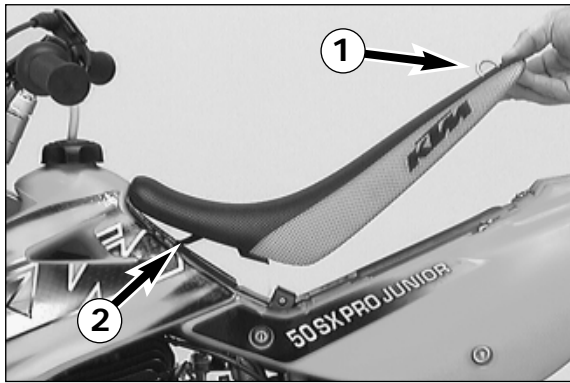

### Removing the seat

The quick-release mechanism ❶ allows removal of the seat without tools. Turn the quick-release device approximately 180° anticlockwise, lift the rear portion of the seat and pull the seat off backwards. When mounting the seat ensure that the hook ❷ engages at the tank.

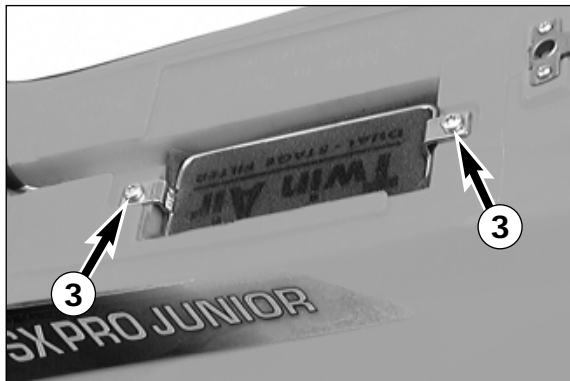

### Cleaning the air filter \*

The air filter must be cleaned at intervals depending on the amount of dust accumulated. To clean the air filter, first remove the seat. Then remove the two screws ❸, the filter holder and the air filter ❹. The air filter consists of a foam rubber insert soaked with filter oil.

**! CAUTION !**

DO NOT CLEAN FOAM FILTER WITH FUEL OR PETROLEUM SINCE THESE WILL DAMAGE THE FOAM. KTM RECOMMENDS THE PRODUCTS MADE BY PUTOLINE FOR AIR FILTER MAINTENANCE. „ACTION CLEANER“ FOR CLEANING PURPOSES AND „ACTION FLUID“ TO OIL THE FOAM FILTER.

Thoroughly wash the foam filter in special cleaning fluid and allow it to dry well. Only press out the filter, do not wring it out under any circumstances. Oil the dry foam filter with a high-grade filter oil. Also clean the air filter box. Check carburetor collar for damage and that it is filled correctly.



Insert the air filter in the opening and fasten it with the filter holder. Then mount the seat.

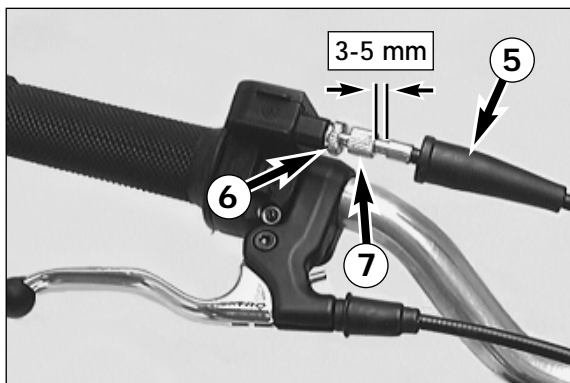

### Adjusting the throttle cable \*

There must always be a 3-5 mm (0.1-0.2 in) play in the throttle cable. To check this, move back the protective cover ❺ on the throttle grip. You must be able to lift the outer covering of the cable 3-5 mm from the adjusting screw ❷, until resistance is felt.

To adjust, loosen the counter nut ❻ and turn the adjusting screw accordingly. Finally tighten counter nut and slide the protective cover back on.

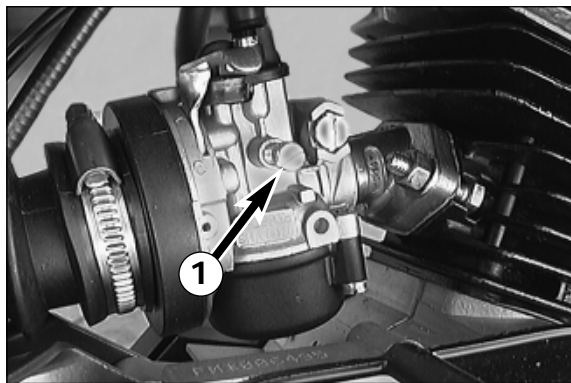

### Adjusting the idle speed (Dell'Orto SHA 1412) \*

The idle speed can be adjusted with idle screw ❶.

Turning in clockwise direction will increase the idle speed.  
Turning in counterclockwise direction will reduce the idling speed.

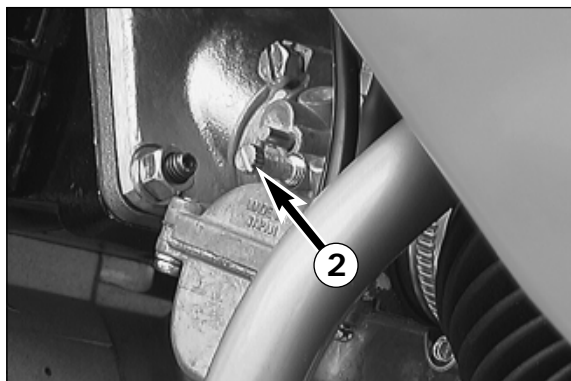

### Adjusting the idle speed (Mikuni VM18-144 / 16-519) \*

The idle speed can be adjusted with idle screw ❷.

Turning in clockwise direction will increase the idle speed.  
Turning in counterclockwise direction will reduce the idling speed.

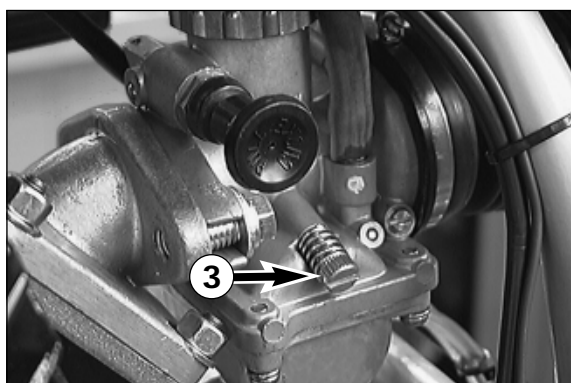

### Adjusting the idle speed (Mikuni VM20-364) \*

The idle speed can be adjusted with idle screw ❸.

Turning in clockwise direction will increase the idle speed.  
Turning in counterclockwise direction will reduce the idling speed.

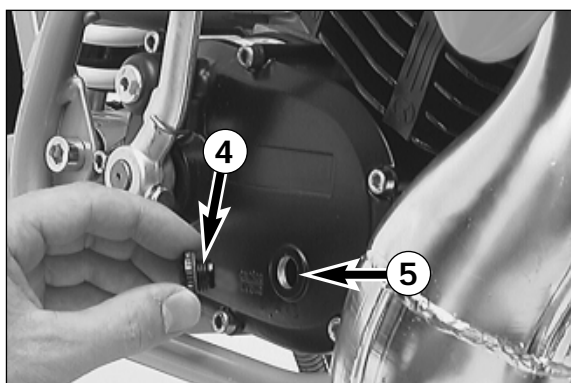

### Checking the gear oil level

To check the gear oil level, first remove the plug ❹. With the motorcycle parked in an upright position, a small quantity of oil should flow out of the indicator opening ❺. If oil must be added, tilt the motorcycle and pour gear oil SAE 30 (ex. Shell Advance VSX 4) into the opening.

**! CAUTION !**

TOO LITTLE OIL OR A POOR OIL QUALITY LEAD TO PREMATURE TRANSMISSION WEAR.  
THEREFORE, ONLY USE BRANDED PRODUCTS (EX. SHELL ADVANCE VSX 4).

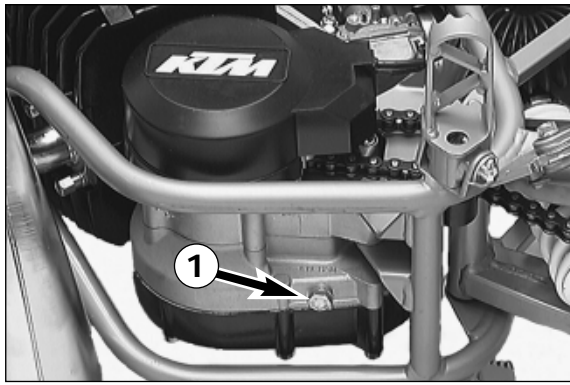

### Changing the gear oil \*

The engine must be warmed up before changing the gear oil. Park the motorcycle on a horizontal surface, remove the oil drain plug ❶ and drain the used oil into an appropriate container. Clean the sealing surface, mount the oil drain plug together with the gasket and tighten with 15 Nm (11 ft.lb).

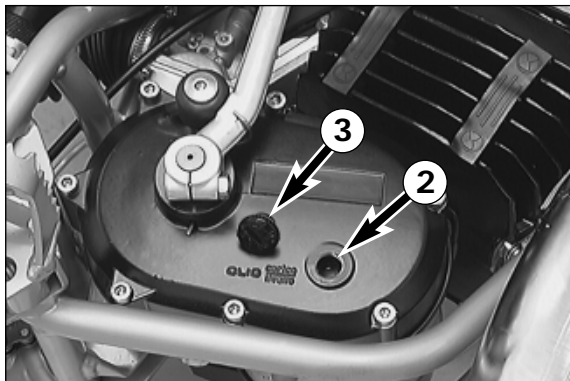

Lay the motorcycle on its side and add 0.25 l gear oil SAE 30 (ex. Shell Advance VSX 4). Mount the plug ❸ and check the engine for leaks.

**! CAUTION !**

TOO LITTLE OIL OR A POOR OIL QUALITY LEAD TO PREMATURE TRANSMISSION WEAR. THEREFORE, ONLY USE BRANDED PRODUCTS.

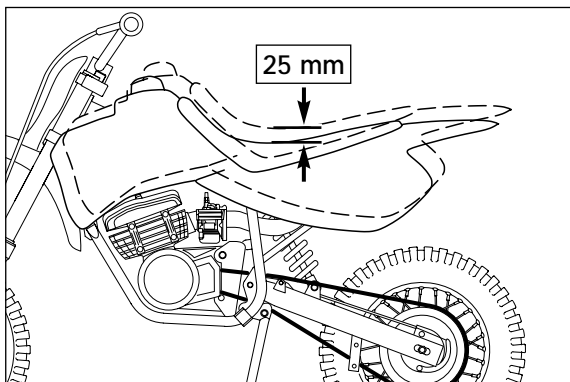

### Changing the seat height

The seat height of all 50 SXR models can easily be increased by 25 mm (1 in). The frame is provided with additional fastening points on which the tank and the tail can be mounted. Thus, you can easily adjust the seat height as your youngster grows.

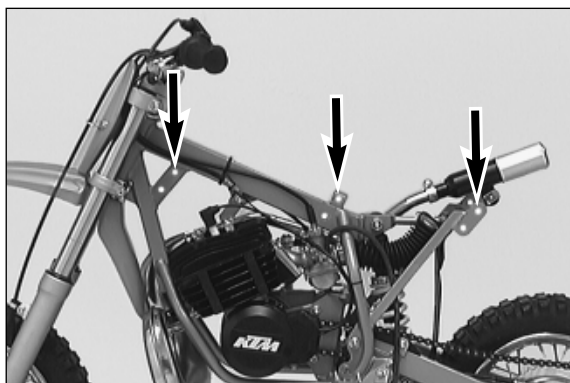

## TECHNICAL DATA – ENGINE S5-E, S5-GS '99

Engine	S5-E (Adventure)	S5-GS (Pro Junior, Pro Senior)
Design	air cooled single cylinder 2-stroke engine	air cooled single cylinder 2-stroke engine with reed valve inlet
Displacement	49.8 ccm	
Bore/Stroke	39 / 41.7 mm	
Compression ratio	9 : 1	
Fuel	SUPER fuel, research octane no 95, mixed with 2-stroke oil	
Oil/gasoline ratio	40 when using high grade 2-stroke oil (Shell Advance Racing X), When in doubt, please contact your importer or use 1 : 33 mix ratio to be on the safe side	
Lubrication	mixture lubrication	
Crankshaft bearing	2 grooved ball bearing	
Connecting rod bearing	needle bearing	
Piston pin bearing	needle bearing	
Piston rings	1 L-ring, 1 rectangular ring	2 rectangular ring
Primary drive	helical gears, 15 : 52 t, cast	helical gears, 15 : 52 t, milled
Transmission oil	0.25 l gear oil, SAE 30 (Shell Advance VSX4)	
Spark plug	Bosch W 4 AC	
Electrode gap	0.6 mm	
Carburetor	Dell'Orto SHA 1412	Pro Jr.: Mikuni VM 18-144 / Pro Jr.USA: Mikuni VM16-519 / Pro Sr.: Mikuni VM 20-364
Air filter		wet foam type air filter insert

**TOLERANCES AND FITTING CLEARANCES**

Engine	S5-E	S5-GS
Crankshaft	run out of crank stud max. 0.050 mm	max. 0.050 mm
Conrod bearing	radial play axial play max. 0.022 mm max. 0.045 mm	max. 0.022 mm max. 0.045 mm
Cylinder	diameter bore fitting clearance max. 39.026 mm max. 0.070 mm	max. 39.024 mm max. 0.028 mm
Piston ring	piston ring end gap max. 0.55 mm	max. 0.55 mm

**TIGHTENING TORQUES - ENGINE**

Hexagon nut primary gear	M 12x1,25	40 Nm (30 ft.lb)
Hexagon nut flywheel	M 8	35 Nm (25 ft.lb)
Nut for clutch hub	M 10	Loctite 242 + 35 Nm (25 ft.lb)
Nuts cylinder head	M 6	12 Nm (8 ft.lb)
Nuts exhaust pipe	M 6	12 Nm (8 ft.lb)
Oil drain plug	M 8	15 Nm (10 ft.lb)
Other screws engine	M 5 M 6	7 Nm (5 ft.lb) 10 Nm (7 ft.lb)

**BASIC CARBURETOR SETTING**

Type	Dell'Orto SHA 1412	Mikuni VM 16-519	Mikuni VM 18-144	Mikuni VM 20-364
Main jet	60	70	70	110
Needle jet	--	D-8	145	N-6
Idling jet	--	25	30	30
Jet needle	--	3DJ3-3	4F18-4	4J13-3
Needle position from top	--	3.	4.	3.
Mixt. reg. screw open	--	2,0 turn	1.5 turn	1.5 turn
Throttle valve	--	2,5	1	2

# TECHNICAL SPECIFICATIONS - CHASSIS 50 SXR Adventure, Pro Junior, Pro Senior '99

	Adventure	Pro Junior	Pro Senior
Frame	single downtube, split-cradle		
Fork	telescopic fork (Paiolo)		
Wheel travel front/rear	115/135 mm (4.5/5.3 in)	140/160 mm (5.5/6.3 in)	165/170mm (6.5/6.7 in)
Rear suspension	central shock absorber (Paioli)		
Front brake	internal expanding, single/cam drum brake Ø 90 mm (3.5")		
Rear brake	internal expanding, single/cam drum brake Ø 90 mm (3.5")		
Tyres	front / rear: Vee Rubber 2.50x10" VRM-140		
Air pressure	front / rear: 1.0 bar (14 psi) / 1.0 bar (14 psi)		
Fuel tank capacity	2.9 liter (0,75 USgal)		
Final drive ratio	10 : 45 t	11 : 45 t	
Chain	1/2 x 3/16" (415) 94 rolls		1/2 x 3/16" (415) 102 rolls
Steering angle	63°		
Wheel base	895 mm (35.2 in)	910 mm (35.8 in)	1030 mm (40.5")
Seat height, unloaded	560 / 585 mm (22 / 23 in) (adjustable)	585 / 610 mm (23 / 24 in) (adjustable)	650 / 675 mm (25.6 / 26.6 in) (adjustable)
Ground clearance	205 mm (8 in)	230 mm (9.05 in)	255 mm (10")
Dead weight without fuel	39 kg (86 lbs)	39.5 kg (87.2 lbs)	40.5 kg (89.4 lbs)
Rider's body height	max. 130 cm (51 in)		
Rider's body weight	max 35 kg (78 lbs)		
Recommended age of rider	4 to 6 years		7 to 8 years
Engine	S5-E	S5-GS	

## TIGHTENING TORQUES

Hexagon nuts front axle	M 12x1	30 Nm (22 ft.lb)
Hexagon nuts rear axle	M 12x1	30 Nm (22 ft.lb)
Hexagon nut swing arm bolt	M 10	20 Nm (15 ft.lb)
Clamping screw upper fork bridge	M 8	15 Nm (11 ft.lb)
Clamping screw lower fork bridge	M 8	15 Nm (11 ft.lb)
Other screws chassis	M 6	10 Nm (7 ft.lb)
	M 8	25 Nm (19 ft.lb)
	M 10	45 Nm (33 ft.lb)

## STANDARD-ADJUSTMENT - FORK

	Adventure	Pro Junior	Pro Senior
Spring	2,55 N/mm	2,55 N/mm	2,55 N/mm
Spring preload	10 mm (0.4 in)	20 mm (0.8 in)	15 mm (0.6 in)
Capacity per fork leg	--	ca 150 ccm	ca 160 ccm
Fork oil	--	SAE 7.5	SAE 7.5

K T M - S P O R T M O T O R C Y C L E A G  
A-5230 Mattighofen • Postfach 91 • Austria  
Internet: <http://www.ktm.co.at>  
FN 102019 d - Landesgericht Ried im Innkreis

