

# OWNER'S MANUAL 2010

**65 SX**

Art. no. 3211478en



**KTM**



Congratulations on your decision to purchase a KTM motorcycle. You are now the owner of a state-of-the-art sports motorcycle that will give you and your child enormous pleasure if you service and maintain it accordingly.

We wish you great pleasure riding the vehicle!

Enter the serial numbers of your vehicle below.

Chassis number (☛ p. 9)	Dealer's stamp
Engine number (☛ p. 9)	

The owner's manual corresponded to the latest state of this series at the time of printing. Slight deviations resulting from continuing development and design can, however, not be completely excluded.

All specifications are non-binding. KTM Sportmotorcycle AG specifically reserves the right to modify or delete technical specifications, prices, colors, forms, materials, services, designs, equipment, etc., without prior notice and without specifying reasons, to adapt these to local conditions, as well as to stop production of a particular model without prior notice. KTM accepts no liability for delivery options, deviations from illustrations and descriptions, as well as misprints and other errors. The models portrayed partly contain special equipment that does not belong to the regular scope of delivery.

© 2009 by KTM-Sportmotorcycle AG, Mattighofen Austria

All rights reserved

Reproduction, even in part, is permitted only with the express written permission of the copyright owner.















































ISO 9001(12 100 6061)

According to the international quality management standard ISO 9001, KTM uses quality assurance processes that lead to the maximum possible quality of the products.

Issued by: TÜV Management Service





KTM-Sportmotorcycle AG  
5230 Mattighofen, Austria

MEANS OF REPRESENTATION .....	4	Removing the fork legs 	26
IMPORTANT INFORMATION .....	5	Installing the fork legs 	27
VIEW OF VEHICLE.....	7	Removing the fork protector 	27
View of the vehicle from the left front (example) .....	7	Installing the fork protector 	28
View of the vehicle from the right rear (example) .....	8	Removing the lower triple clamp 	28
LOCATION OF SERIAL NUMBERS .....	9	Installing the lower triple clamp 	29
Chassis number.....	9	Greasing the steering head bearing 	29
Engine number.....	9	Dismounting the front fender .....	30
Shock absorber part number .....	9	Installing the front fender.....	30
CONTROLS .....	10	Dismounting the start number plate .....	30
Throttle grip .....	10	Installing the start number plate .....	30
Clutch lever .....	10	Handlebar position .....	31
Hand brake lever .....	10	Adjusting handlebar position 	31
Short circuit button .....	10	Checking the play in the throttle cable.....	32
Fuel tap.....	10	Adjusting the play in the throttle cable 	32
Opening filler cap.....	11	Checking chain dirt .....	32
Closing filler cap .....	11	Cleaning the chain.....	32
Choke.....	11	Removing the chain guard 	33
Shift lever.....	11	Installing the chain guard.....	33
Kickstarter .....	12	Checking the chain tension .....	33
Foot brake pedal .....	12	Checking the chain tension - installing rear wheel.....	34
Plug-in stand .....	12	Checking rear sprocket / engine sprocket for wear .....	34
GENERAL TIPS AND HINTS ON PUTTING INTO OPERATION.....	13	Adjusting the chain tension .....	34
Advice on first use .....	13	Adjusting chain tension - after checking .....	35
Running in the engine.....	14	Adjusting chain tension - installing rear wheel.....	35
RIDING INSTRUCTIONS .....	15	Adjusting the chain guide 	36
Checks before putting into operation .....	15	Adjusting basic position of clutch lever.....	36
Starting .....	15	Checking the fluid level of hydraulic clutch.....	36
Starting up .....	16	Changing the hydraulic clutch fluid 	36
Shifting, riding.....	16	Checking brake discs .....	37
Braking .....	16	Checking free play of hand brake lever.....	38
Stopping, parking.....	17	Adjusting basic position of handbrake lever.....	38
Refueling.....	17	Checking the front brake fluid level .....	38
SERVICE SCHEDULE.....	18	Adding front brake fluid 	39
Important maintenance work to be carried out by an authorized KTM workshop. ....	18	Checking the front brake linings.....	40
Important maintenance work to be carried out by an authorized KTM workshop. (as additional order).....	19	Removing front brake linings 	40
Performance of urgent inspection and maintenance work by the supervisory individual.....	19	Installing the front brake linings 	40
MAINTENANCE WORK ON CHASSIS AND ENGINE.....	20	Changing the front brake linings 	41
Jacking up the motorcycle.....	20	Checking the free travel of the foot brake lever .....	42
Removing the motorcycle from the work stand.....	20	Adjusting the free travel of the foot brake pedal 	42
Adjusting the compression damping of the shock absorber .....	20	Adjusting the basic position of the foot brake pedal 	42
Adjusting the rebound damping of the shock absorber.....	20	Checking rear brake fluid level .....	43
Measuring rear wheel sag unloaded .....	21	Adding rear brake fluid 	43
Checking the static sag of the shock absorber .....	21	Checking the rear brake linings.....	44
Checking the riding sag of the shock absorber .....	21	Removing rear brake linings 	44
Adjusting the spring preload of the shock absorber 	22	Installing the rear brake linings 	45
Adjusting the riding sag 	22	Changing the rear brake linings 	46
Removing the shock absorber 	23	Removing the front wheel 	46
Installing shock absorber 	23	Installing the front wheel 	47
Adjusting the compression damping of the fork .....	23	Removing the rear wheel 	47
Adjusting the rebound damping of the fork.....	23	Installing the rear wheel 	48
Vehicle level .....	24	Checking the tire condition.....	48
Adjusting the fork overhang 	24	Checking tire air pressure.....	49
Bleeding fork legs.....	25	Checking spoke tension.....	49
Cleaning the dust boots of the fork legs .....	25	Removing the seat.....	50
Checking play of steering head bearing .....	25	Mounting the seat .....	50
Adjusting play of steering head bearing 	26	Cooling system .....	50
		Checking the antifreeze and coolant level .....	50
		Checking the coolant level.....	51
		Draining the coolant 	52
		Refilling coolant 	52

Glass fiber yarn filling of main silencer .....	53
Removing main silencer .....	53
Installing the main silencer .....	53
Removing the glass fiber yarn filling of the main silencer  .....	53
Installing the glass fiber yarn filling of the main silencer  .....	54
Removing the air filter  .....	54
Installing the air filter  .....	54
Cleaning air filter  .....	55
Carburetor - idle .....	55
Carburetor - adjusting the idle speed  .....	55
Emptying the carburetor float chamber  .....	56
Checking gear oil level .....	57
Changing the gear oil  .....	57
Draining the gear oil  .....	57
Filling up with gear oil  .....	58
Adding gear oil  .....	58
TRUBLESHOOTING.....	60
CLEANING.....	62
Cleaning motorcycle .....	62
STORAGE .....	63
Storage.....	63
Putting into operation after storage .....	63
TECHNICAL DATA - ENGINE.....	64
Capacity - gear oil.....	64
Capacity - coolant.....	64
TECHNICAL DATA - ENGINE TIGHTENING TORQUES.....	65
TECHNICAL DATA - CARBURETOR.....	66
Basic setting.....	66
Carburetor configuration.....	66
TECHNICAL DATA - CHASSIS .....	68
Tires .....	68
Capacity - fuel.....	68
TECHNICAL DATA - FORK.....	69
TECHNICAL DATA - SHOCK ABSORBER .....	70
TECHNICAL DATA - TIGHTENING TORQUES FOR CHASSIS .....	71
OPERATING SUBSTANCES.....	72
AUXILIARY SUBSTANCES.....	74
STANDARDS.....	76
INDEX .....	77

## Symbols used

The symbols used are explained in the following.

- 
- |  |  |
|--|--|
|  | Indicates an expected reaction (e.g. of a work step or a function).  |
|  | Indicates an unexpected reaction (e.g. of a work step or a function).  |
|  | All work marked with this symbol requires specialist knowledge and technical understanding. In the interest of the safety of your child, have these jobs done in an authorized KTM workshop! There, your motorcycle will be serviced optimally by specially trained experts using the specialist tools required. |
|  | Identifies a page reference (more information is provided on the specified page).  |
- 

## Formats used

The typographical and other formats used are explained in the following.

- 
- |                          |  |
|--------------------------|--|
| <b>Proper name</b>       | Identifies a proper name.                  |
| <b>Name<sup>®</sup></b>  | Identifies a protected name.               |
| <b>Brand<sup>™</sup></b> | Identifies a brand in merchandise traffic. |
-

## Use definition

KTM sport motorcycles are designed and built to withstand the normal stresses and strains of competitive use. The motorcycles comply with currently valid regulations and categories of the top international motorsport organizations.



### Info

The motorcycle must be used only in closed off areas remote from public road traffic.

## Maintenance

A prerequisite for perfect operation and prevention of wear is that the engine and chassis maintenance and adjustment work described in the owner's manual are properly carried out. Poor adjustment and tuning of the engine and chassis can lead to damage and breakage of components.

Using the motorcycle in difficult conditions such as on sand or very muddy or wet terrain can lead to above-average wear of components such as the transmission train or the brakes. For this reason, it may be necessary to service or replace worn parts before the limit specified in the service schedule is reached.

Pay careful attention to the prescribed running-in period, inspection and maintenance intervals. If you observe these exactly, you will ensure a much longer service life for your motorcycle.

## Warranty

The work prescribed in the service schedule must be carried out in an authorized KTM workshop only and confirmed in the customer's service record, since otherwise no warranty claims will be honored. No warranty claims can be honored for damage resulting from manipulations and/or alterations to the vehicle.

## Fuel, oils, etc.

You should use the fuels, oils and greases according to specifications as listed in the owner's manual.

## Spare parts, accessories

For your own safety, only use spare parts and accessory products that have been approved and/or recommended by KTM and have them installed by an authorized KTM workshop. KTM accepts no liability for other products and any resulting damage or loss. Certain spare parts and accessories are specified in parentheses in the descriptions. Your KTM dealer will be glad to advise you.

The current **KTM PowerParts** for your vehicle can be found on the KTM website.

International KTM Website: <http://www.ktm.com>

## Work rules

Special tools are needed for certain tasks. They are not included with the vehicle but can be ordered under the number in parentheses. Ex.: bearing puller (15112017000)

During assembly, non-reusable parts (e.g. self-locking screws and nuts, seals, seal rings, O-rings, pins, lock washers) must be replaced by new parts.

If a thread locker is used for the screw connections (e.g. **Loctite**®), follow the specific manufacturer instructions regarding its use.

Parts that are to be reused after disassembly must be cleaned and checked for damage and wear. Change damaged or worn parts.

After repair and maintenance, ensure that the vehicle is roadworthy.

## Transport

### Note

**Danger of damage** The parked vehicle can roll away or fall over.

- Always place the vehicle on a firm and even surface.

### Note

**Fire hazard** Some vehicle components get very hot when the machine is driven.

- Do not place the vehicle where there are flammable or explosive substances. Do not place objects over the vehicle while it is still warm from being run. Always let the vehicle cool first.

- Switch off the engine.

- Use straps or other suitable devices to secure the motorcycle against accidents or falling over.

## Environment

Motorcycling is a wonderful sport and we naturally hope that you and your child will be able to enjoy it to the fullest. However, it is a potential problem for the environment and can lead to conflicts with other persons. But if you use your motorcycle responsibly, you can ensure that such problems and conflicts do not have to occur. To protect the future of motorcycle sport, make sure that your child uses the motorcycle legally, display environmental consciousness, and respect the rights of others.

## notes/warnings

Be sure to pay attention to the notes and warnings given here.



### Info

Various notes and warning stickers are attached to the vehicle. Do not remove any notes and warning stickers. If they are missing, you or others may not recognize sources of danger and may therefore be injured.

## Grades of risks



### Danger

Indicates immediate danger that will invariably lead to severe or even fatal injury if the appropriate measures are not taken.



### Warning

Indicates immediate danger that may lead to severe or even fatal injury if the appropriate measures are not taken.

### Note

Identifies a danger that will lead to considerable machine and material damage if the appropriate measures are not taken.



### Warning

Indicates immediate danger that will invariably lead to environmental damage if the appropriate measures are not taken.

## Owner's manual

- Carefully read this owner's manual in its entirety together with your child before letting your child ride the motorcycle for the first time. It contains a lot of information and tips to help you and your child operate and handle the motorcycle. Only then will you find out how to customize the motorcycle ideally for your child's use and how to protect your child from injury. The owner's manual also contains important information on servicing the motorcycle.
- The owner's manual is an important component of the motorcycle and should be handed over to the new owner if the vehicle is sold.



## View of the vehicle from the left front (example)



1	Hand brake lever
2	Clutch lever
3	Quick release for seat lock
4	Front brake caliper
5	Fuel tap
6	Choke lever
7	Shift lever
8	Footrest
9	Shock absorber rebound adjustment

## View of the vehicle from the right rear (example)

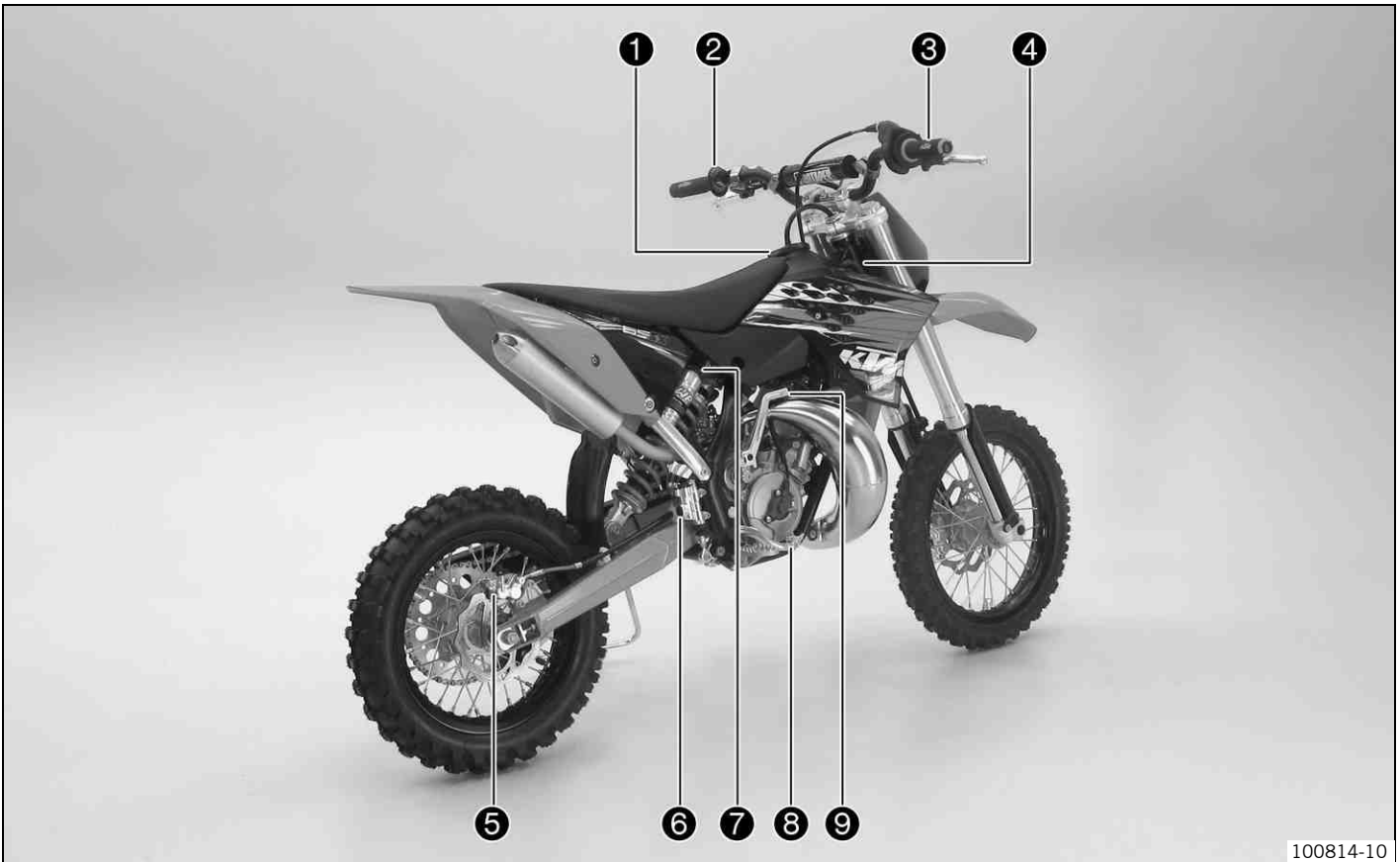

100814-10

- |   |                                       |
|---|---------------------------------------|
| 1 | Filler cap                            |
| 2 | Short circuit button                  |
| 3 | Throttle grip                         |
| 4 | Chassis number                        |
| 5 | Rear brake caliper                    |
| 6 | Level viewer for brake fluid, rear    |
| 7 | Shock absorber compression adjustment |
| 8 | Foot brake pedal                      |
| 9 | Kickstarter                           |

## Chassis number

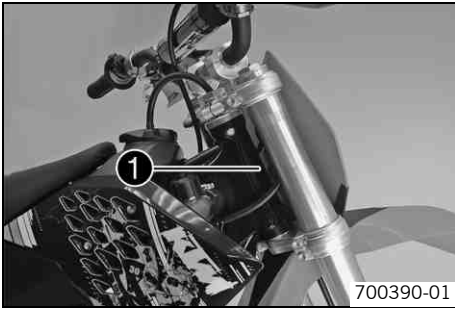

The chassis number ❶ is stamped on right of the steering head.

## Engine number

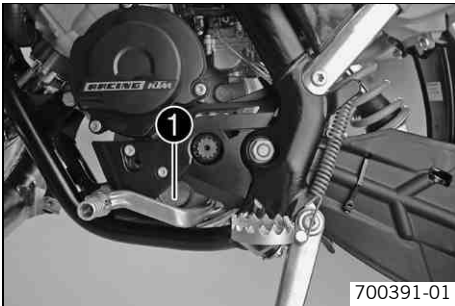

The engine number ❶ is stamped on the left side of the engine under the engine sprocket.

## Shock absorber part number



The shock absorber part number ❶ is stamped on the top of the shock absorber above the adjusting ring on the engine side.

## Throttle grip



Throttle grip ❶ is fitted on the right side of the handlebar.

## Clutch lever



The clutch lever ❶ is fitted on the left side of the handlebar. The clutch is hydraulically operated and self-adjusting.

## Hand brake lever



Hand brake lever ❶ is fitted on the right side of the handlebar. The hand brake lever is used to activate the front brake.

## Short circuit button

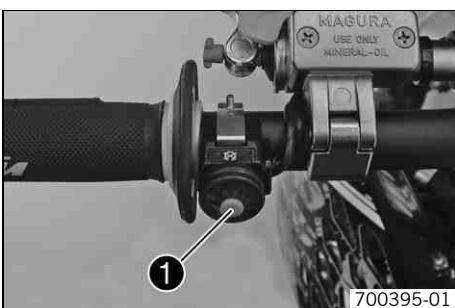

Short circuit button ❶ is fitted on the left side of the handlebar.

### Possible states

- Short circuit button ☒ in basic position – In this position, the ignition circuit is closed, and the engine can be started.
- Short circuit button ☒ pressed – In this position, the ignition circuit is interrupted, a running engine stops, and a non-running engine will not start.

## Fuel tap

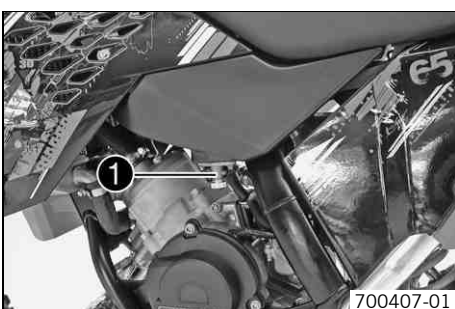

Fuel tap ❶ is on the left of the fuel tank.

### Possible states

- Fuel tap is closed – The knurled screw is turned all the way clockwise. Fuel cannot flow out of the fuel tank.
- Fuel tap is open – The knurled screw is turned all the way counterclockwise. Fuel can flow out of the fuel tank.

## Opening filler cap

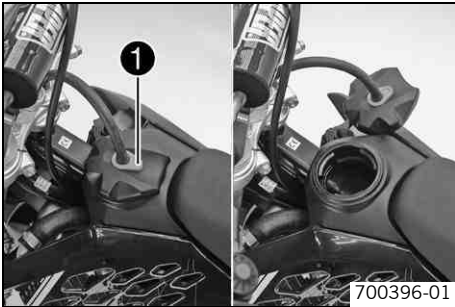

- Press release button **1**, turn filler cap counterclockwise and lift it free.

## Closing filler cap

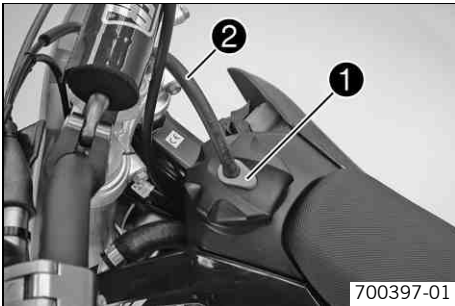

- Replace the filler cap and turn clockwise until the release button **1** locks in place.



### Info

Run the fuel tank breather hose **2** without kinks.

## Choke



Choke lever **1** is fitted on the left side of the carburetor.

Activating the choke function frees an opening through which the engine can draw extra fuel. This gives a richer fuel-air mixture, which is needed for a cold start.



### Info

If the engine is warm, the choke function must be deactivated.

### Possible states

- Choke function activated – The choke lever is pushed down all the way.
- Choke function deactivated – The choke lever is pushed up all the way.

## Shift lever

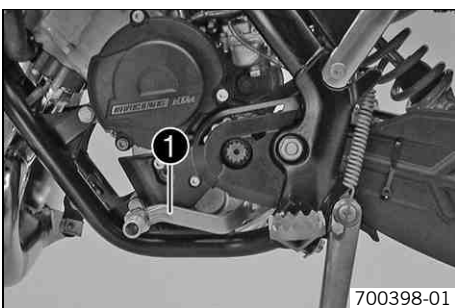

Shift lever **1** is mounted on the left side of the engine.

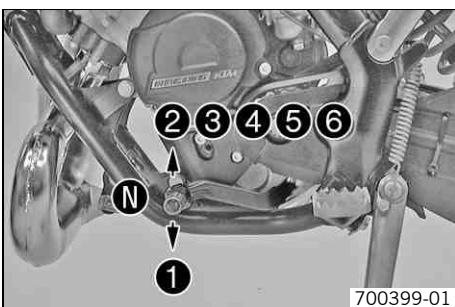

The gear positions can be seen in the photograph.

The neutral or idle position **N** is between the first and second gears.

## Kickstarter

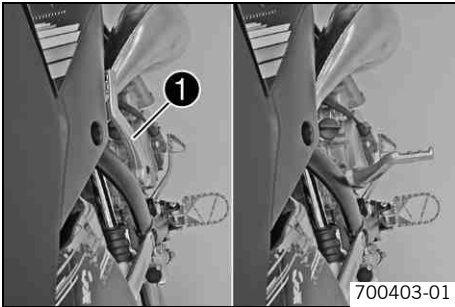

The kickstarter ❶ is fitted on the right of the engine.  
The kickstarter can be swiveled.

**i** **Info**

Before riding, swing the kickstarter inwards towards the engine.

## Foot brake pedal

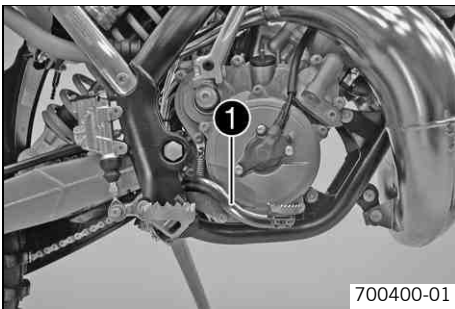

Foot brake pedal ❶ is located in front of the right footrest.  
The foot brake pedal is used to activate the rear brake.

## Plug-in stand

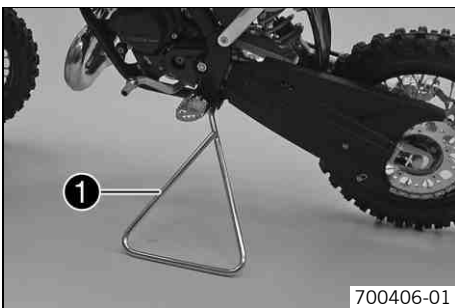

**Note**

**Danger of damage** The parked vehicle can roll away or fall over.

- Always place the vehicle on a firm and even surface.

To park the motorcycle, insert plug-in stand ❶ into the plug-in stand bracket on the left side of the vehicle.

**i** **Info**

Remove the plug-in stand before riding.

## Advice on first use

-  **Warning**  
**Danger of accidents** Physical and mental readiness of a child.
- Your child must be able to ride a bicycle and must be able to erect the vehicle independently after a fall. In addition, your child must understand the regulations and instructions from you or from other guardians. Do not ask too much of your child; participation in a race should not be considered until your child's stamina, riding techniques and motivation are at the necessary levels. Children often underestimate or fail to recognize dangerous situations; make it clear to your child that it should not, under any circumstances, operate the vehicle without supervision and that your child may only drive at speeds that are commensurate with the child's riding abilities and the road conditions.
  - Only let your child ride on the vehicle if it is physically and mentally ready to operate the vehicle.

-  **Warning**  
**Risk of injury** Missing or poor protective clothing present an increased safety risk.
- Wear protective clothing (helmet, boots, gloves, pants and jacket with protectors) every time you ride the motorcycle. You and your child should always use protective clothing that is in good condition and meets the legal requirements. When you ride a motorcycle, set an example for your child and wear suitable protective clothing.

-  **Warning**  
**Danger of crashing** Impairment of handling characteristic due to different tire tread patterns on front and rear wheels.
- The front and rear wheels must be fitted with tires with similar tread patterns to prevent loss of control over the vehicle.

-  **Warning**  
**Danger of accidents** Critical riding behavior due to inappropriate riding.
- Ensure that your child adjusts the riding speed to the road conditions and to his or her riding abilities.

-  **Warning**  
**Danger of accidents** Accident risk caused by presence of a passenger.
- Your vehicle is not designed to carry passengers. Do not ride with a passenger.

-  **Warning**  
**Danger of accidents** Brake system failure.
- If the foot brake pedal is not released, the brake linings drag permanently. The rear brake can fail due to overheating. Ensure that your child raises his or her foot from the foot brake pedal when the child does not want to brake.

-  **Warning**  
**Danger of accidents** Destruction of chassis components.
- Do not exceed the maximum allowable rider weight.

-  **Warning**  
**Risk of misappropriation** Usage by unauthorized persons.
- Never leave the vehicle while the engine is running. Secure the vehicle against use by unauthorized persons.

- 
-  **Info**  
 When using your motorcycle, remember that others may feel disturbed by excessive noise.

- Make sure that the pre-delivery inspection work has been carried out by an authorized KTM workshop. You receive a delivery certificate and the service record at vehicle handover.
- Carefully read the entire owner's manual together with your child before going for the first ride.

- 
-  **Info**  
 Pay special attention to the safety warnings and injury risks.  
 Explain to your child the techniques of riding and falling, e.g. how shifting weight can influence handling characteristics.

- Familiarize your child with the controls.
- Adjust the basic position of clutch lever. (☛ p. 36)
- Adjust the basic position of the handbrake lever. (☛ p. 38)
- Adjust the basic position of the foot brake pedal. ☛ (☛ p. 42)
- Before using the vehicle for the first time, ensure that the basic settings of the chassis are suitable for the weight of your child.

- Accustom your child to the handling of the motorcycle on suitable terrain, preferably on a large open meadow.

**Info**

To give your child a feel for the brake, you should push your child at first. Do not start the engine until your child can is able to apply the necessary brake pressure.

Initially, let your child ride to another person who can help your child stop and turn.

- Erect obstacles for your child to navigate around to accustom your child to handling the vehicle.
- Your child should also try to ride as slowly as possible and in a standing position to get a better feeling for the vehicle.
- Do not let your child ride on terrain that exceeds your child's capabilities and experience.
- Your child should hold the handlebar firmly with both hands and keep his or her feet on the footrests when riding.
- Do not exceed the maximum allowable rider weight.

## Guideline

Maximum rider weight	< 50 kg (< 110 lb.)
----------------------	---------------------

- Check the spoke tension. (🔧 p. 49)

**Info**

The spoke tension must be checked after riding the motorcycle for one half hour.

- Run the engine in. (🔧 p. 14)

## Running in the engine

- During the running-in phase, do not exceed the specified engine performance.

## Guideline

Maximum engine performance	
During the first 3 service hours	< 70 %
During the first 5 service hours	< 100 %

- Avoid fully opening the throttle!



## Checks before putting into operation



### Info

Make sure that the motorcycle is in a perfect technical condition before use.



### Info

In the interests of riding safety, make it your own and your child's habit to perform a general check before going for a ride. Insist that your child perform the general checks himself or herself.

- Check the gear oil level. (🔧 p. 57)
- Check the chain tension. (🔧 p. 33)
- Check the chain dirt accumulation. (🔧 p. 32)
- Check the tire condition. (🔧 p. 48)
- Check the tire air pressure. (🔧 p. 49)
- Check the front brake fluid level. (🔧 p. 38)
- Check the rear brake fluid level. (🔧 p. 43)
- Check the front brake linings. (🔧 p. 40)
- Check the rear brake linings. (🔧 p. 44)
- Check the brake system function.
- Check the coolant level. (🔧 p. 51)
- Check the settings of all controls and ensure that they can be operated smoothly.
- Check that the electrical equipment is functioning properly.

## Starting



### Danger

**Danger of poisoning** Exhaust gases are poisonous and can result in unconsciousness and/or death.

- When running the engine, always make sure there is sufficient ventilation, and do not start or run the engine in a closed space without an effective exhaust extraction system.

### Note

**Engine failure** High engine speeds in cold engines have a negative effect on the service life of the engine.

- Always warm up the engine at low engine speeds.



### Info

If the motorcycle is unwilling to start, the cause can be old fuel in the float chamber. The flammable elements of the fuel evaporate after a long time of standing.

If the float chamber is filled with fresh fuel, the engine starts immediately.

### Engine has been out of use for more than 1 week

- Empty the carburetor float chamber. 🛠️ (🔧 p. 56)
- Turn the knurled screw on the fuel tap all the way counterclockwise.
  - ✓ Fuel can flow from the fuel tank to the carburetor.
- Remove the motorcycle from the stand.
- Shift gear to neutral.

### The engine is cold

- Push the choke lever down all the way.
- Forcefully step on the kickstarter, pushing it all the way down.



### Info

Do not open the throttle.

## Starting up



### Info

The plug-in stand must be removed before riding.

- Pull the clutch lever, engage 1st gear, release the clutch lever slowly and simultaneously open the throttle carefully.

## Shifting, riding



### Warning

**Danger of accidents** If you shift down at high engine speed, the rear wheel can lock up.

- Do not shift into a low gear at high engine speed. The engine races and the rear wheel can lock up.



### Info

If you hear unusual noises while riding, stop immediately, switch off the engine and contact an authorized KTM workshop. First gear is used for starting off or for steep inclines.

- When conditions allow (incline, road situation, etc.), your child can shift into a higher gear. To do so, release the throttle while simultaneously pulling the clutch lever, shift into the next gear, release the clutch and open the throttle.
- If the choke function was activated, deactivate it after the engine has warmed up.
- When you reach maximum speed after fully opening the throttle, turn back the throttle to about  $\frac{3}{4}$  of its range. The speed hardly drops, but the fuel consumption falls considerably.
- Your child should always open the throttle only as much as the engine can handle – abruptly opening the throttle increases fuel consumption.
- To shift down, brake and close the throttle at the same time.
- Pull the clutch lever and shift into a lower gear, release the clutch lever slowly and open the throttle or shift again.
- Your child should switch off the engine if he or she expects to be standing for a long time.

Guideline

≥ 2 min

- Your child should avoid frequent and extended slipping of the clutch. This heats the engine oil, the engine and the cooling system.
- Insist that your child ride with a low rpm instead of with a high rpm and a slipping clutch.

## Braking



### Warning

**Danger of accidents** If you brake too hard, the wheels can lock.

- Adapt your braking to the traffic situation and the road conditions.



### Warning

**Danger of accidents** Reduced braking efficiency caused by spongy pressure point of front or rear brake.

- Check the brake system and do not continue riding. (Your authorized KTM workshop will be glad to help.)



### Warning

**Danger of accidents** Reduced braking efficiency due to wet or dirty brakes.

- Clean or dry dirty or wet brakes by riding and braking gently.

- On sandy, wet or slippery surfaces, use the rear brake.
- Braking should always be completed before you go into a bend. Your child should change down to a lower gear appropriate to the road speed.
- Insist that your child take advantage of the braking action of the engine when riding on long downhill. To do so, shift back one or two gears, but do not overrev the engine. Your child will need to apply the brakes far less often and the brakes are not overheated.

## Stopping, parking

**Warning**  
**Risk of misappropriation** Usage by unauthorized persons.

- Never leave the vehicle while the engine is running. Secure the vehicle against use by unauthorized persons.

**Warning**  
**Danger of burns** Some vehicle components get very hot when the machine is driven.

- Do not touch hot components such as exhaust system, radiator, engine, shock absorber and brakes. Allow these components to cool down before starting work on them.

**Note**  
**Danger of damage** The parked vehicle can roll away or fall over.

- Always place the vehicle on a firm and even surface.

**Note**  
**Fire hazard** Some vehicle components get very hot when the machine is driven.

- Do not place the vehicle where there are flammable or explosive substances. Do not place objects over the vehicle while it is still warm from being run. Always let the vehicle cool first.

**Note**  
**Material damage** Damage and destruction of components due to excessive load.

- The side stand is designed for the weight of the motorcycle only. Do not sit on the motorcycle when it is supported by the side stand only. The side stand and/or the frame could be damaged and the motorcycle could fall over.

- Brake the motorcycle.
- Shift gear to neutral.
- Press and hold the short circuit button ☒ while the engine is idling until the engine stops.
- Turn the knurled screw on the fuel tap all the way clockwise.
- Park the motorcycle on firm ground.

## Refueling

**Danger**  
**Fire hazard** Fuel can easily catch fire.

- Never fill up the vehicle near open flames or burning cigarettes, and always switch off the engine first. Be careful that no fuel is spilt, especially on hot vehicle components. Clean up spilt fuel immediately.
- Fuel in the fuel tank expands when warm and can escape if the tank is overfilled. See specifications on filling up with fuel.

**Warning**  
**Danger of poisoning** Fuel is poisonous and a health hazard.

- Avoid contact of the fuel with skin, eyes and clothing. Do not inhale fuel vapors. If fuel gets into your eyes, rinse immediately with water and contact a doctor. Wash affected skin areas immediately with soap and water. If fuel is swallowed, contact a doctor immediately. Change clothing that has come into contact with fuel.

**Warning**  
**Environmental hazard** Improper handling of fuel is a danger to the environment.

- Do not allow fuel to get into the ground water, the ground, or the sewage system.

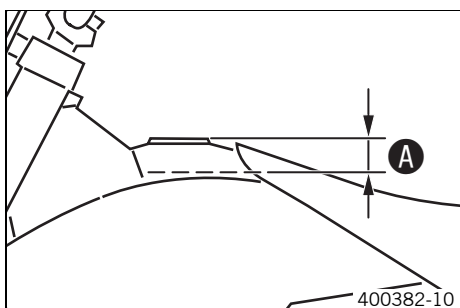

- Switch off the engine.
- Open the filler cap. (☛ p. 11)
- Fill the fuel tank with fuel up to measurement **A**.

Guideline

Measurement of <b>A</b>	35 mm (1.38 in)	
Fuel tank capacity, approx.	3.5 l (3.7 qt.)	Super unleaded gasoline, mixed with 2-stroke engine oil (1:60) (☛ p. 73)

- Close the filler cap. (☛ p. 11)

**Important maintenance work to be carried out by an authorized KTM workshop.**

		S20A	S40A
Engine	Change the gear oil. 🛠️ (📖 p. 57)		•
	Check spark plug and replace if required. 🛠️	•	•
	Clean spark plug connectors and check for tightness. 🛠️	•	•
	Check engine mounting screws for tightness.	•	•
Carburetor	Check intake flange and carburetor connection boot for cracks and leakage.		•
	Check idle.	•	•
	Check vent hoses for damage and routing without sharp bends.		•
Attachments	Check the cooling system for leakage.		•
	Check the antifreeze and coolant level. (📖 p. 50)		•
	Check exhaust system for leakage and looseness.	•	•
	Check throttle cables for damage, smooth operation and routing without sharp bends.		•
	Check the fluid level of the hydraulic clutch. (📖 p. 36)	•	•
	Clean the air filter. 🛠️ (📖 p. 55)	•	•
Brakes	Check the front brake linings. (📖 p. 40)		•
	Check the rear brake linings. (📖 p. 44)		•
	Check the brake discs. (📖 p. 37)		•
	Check the front brake fluid level. (📖 p. 38)	•	•
	Check the rear brake fluid level. (📖 p. 43)	•	•
	Check brake lines for damage and leakage.		•
	Check the free play of the hand brake lever. (📖 p. 38)	•	•
	Check the free travel of the foot brake lever. (📖 p. 42)	•	•
	Check the function of the brake system.	•	•
	Check screws and guide bolts of brake system for tightness.	•	•
Chassis	Check shock absorber and fork for leakage and functioning. 🛠️	•	•
	Clean the dust boots of the fork legs. (📖 p. 25)	•	•
	Bleed fork legs. (📖 p. 25)	•	•
	Check swingarm bearing.		•
	Check play of steering head bearing. (📖 p. 25)		•
	Check all screws to see if they are tight.	•	•
Wheels	Check the spoke tension. (📖 p. 49)	•	•
	Check rim run-out.	•	•
	Check the tire condition. (📖 p. 48)	•	•
	Check the tire air pressure. (📖 p. 49)	•	•
	Check the chain wear.	•	•
	Check the chain tension. (📖 p. 33)	•	•
	Clean the chain. (📖 p. 32)	•	•
	Check wheel bearing for play.	•	•
Clean and grease adjusting screws of chain adjuster.	•	•	

**S20A:** every 20 service hours

**S40A:** every 40 service hours

## Important maintenance work to be carried out by an authorized KTM workshop. (as additional order)

	S20A	S40A	S80A	J1A
Check/set the carburetor components. 🛠️				•
Check the reed valve housing, diaphragm and intake flange. 🛠️	•	•	•	
Check wear of the clutch lining disc. 🛠️	•	•	•	
Check clutch spring length. 🛠️	•	•	•	
Check cylinder and piston for wear. 🛠️	•	•	•	
Check exhaust control for functioning and smooth operation, clean. 🛠️	•	•	•	
Change the spring of the exhaust control. 🛠️		•	•	
Check the seating of the piston pin. 🛠️	•	•	•	
Check main bearing of the crankshaft. 🛠️	•	•	•	
Check radial clearance of conrod bearing. 🛠️	•	•	•	
Change crankshafts and conrod bearings. 🛠️		•	•	
Fully check the transmission. 🛠️		•	•	
Service the fork. 🛠️		•	•	
Service the shock absorber. 🛠️			•	
Clean and lubricate swingarm bearing. 🛠️				•
Grease the steering head bearing. 🛠️ (🔧 p. 29)				•
Change the glass fiber yarn filling of the main silencer. 🛠️	•	•	•	
Change the hydraulic clutch fluid. 🛠️ (🔧 p. 36)				•
Change the front brake fluid. 🛠️				•
Change the rear brake fluid. 🛠️				•

**S20A:** every 20 service hours

**S40A:** every 40 service hours

**S80A:** every 80 service hours

**J1A:** annually

## Performance of urgent inspection and maintenance work by the supervisory individual.

	NB1A
Check the gear oil level. (🔧 p. 57)	•
Check the front brake fluid level. (🔧 p. 38)	•
Check the rear brake fluid level. (🔧 p. 43)	•
Check the front brake linings. (🔧 p. 40)	•
Check the rear brake linings. (🔧 p. 44)	•
Check and adjust throttle cables.	•
Bleed fork legs. (🔧 p. 25)	•
Clean the dust boots of the fork legs. (🔧 p. 25)	•
Clean the chain. (🔧 p. 32)	•
Check the chain tension. (🔧 p. 33)	•
Check the chain wear.	•
Check rear sprocket / engine sprocket for wear. (🔧 p. 34)	•
Clean the air filter. 🛠️ (🔧 p. 55)	•
Check the tire air pressure. (🔧 p. 49)	•
Check the tire condition. (🔧 p. 48)	•
Check the coolant level. (🔧 p. 51)	•
Empty the carburetor float chamber. 🛠️ (🔧 p. 56)	•
Check all controls for smooth operation.	•
Check braking.	•
Check all screws, nuts and hose clamps regularly for tightness.	•

**NB1A:** Depending on conditions of use according to requirements.

## Jacking up the motorcycle

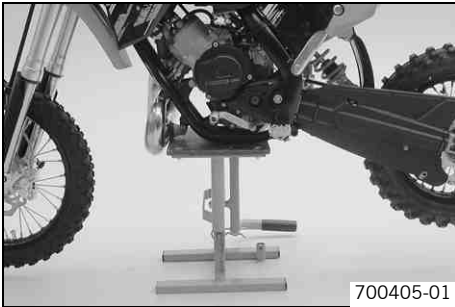

**Note**

**Danger of damage** The parked vehicle can roll away or fall over.

- Always place the vehicle on a firm and even surface.

- Jack up the motorcycle underneath the engine.

Work stand (54829055000)

- Secure the motorcycle against falling over.

## Removing the motorcycle from the work stand

**Note**

**Danger of damage** The parked vehicle can roll away or fall over.

- Always place the vehicle on a firm and even surface.

- Remove the motorcycle from the work stand.
- Remove the work stand.

## Adjusting the compression damping of the shock absorber



**Danger**

**Danger of accidents** Disassembly of pressurized parts can lead to injury.

- The shock absorber is filled with high density nitrogen. Adhere to the description provided. (Your authorized KTM workshop will be glad to help.)

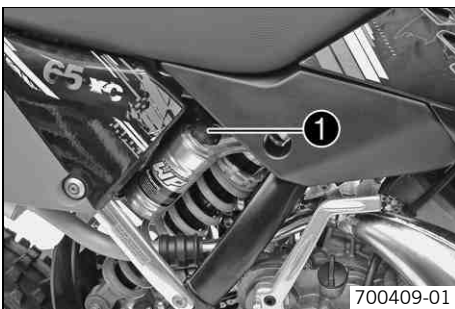

- Turn adjusting knob ❶ counterclockwise all the way.
- Turn clockwise by the number of clicks corresponding to the shock absorber type.

Guideline

Compression damping	
Comfort	10 clicks
Standard	9 clicks
Sport	3 clicks



**Info**

Turn counterclockwise to increase damping, turn clockwise to reduce damping.

## Adjusting the rebound damping of the shock absorber



**Danger**

**Danger of accidents** Disassembly of pressurized parts can lead to injury.

- The shock absorber is filled with high density nitrogen. Adhere to the description provided. (Your authorized KTM workshop will be glad to help.)

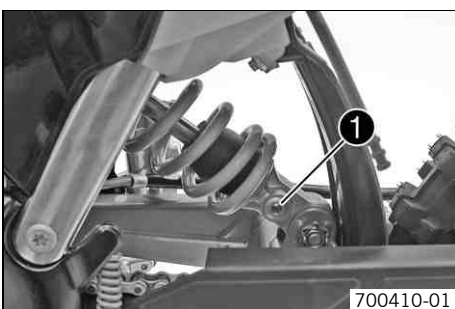

- Turn adjusting screw ❶ clockwise to the last perceptible click.
- Turn back counterclockwise by the number of clicks corresponding to the shock absorber type.

Guideline

Rebound damping	
Comfort	10 clicks
Standard	9 clicks
Sport	6 clicks



**Info**

Turn clockwise to increase damping, turn counterclockwise to reduce suspension damping.

### Measuring rear wheel sag unloaded

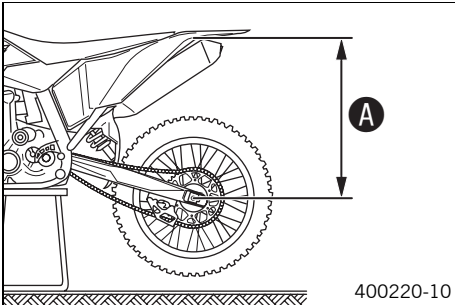

- Jack up the motorcycle. (☞ p. 20)
- Measure the distance – as vertical as possible – between the rear axle and a fixed point, for example, a mark on the side cover.
- Make a note of the value as measurement **A**.
- Remove the motorcycle from the work stand. (☞ p. 20)

### Checking the static sag of the shock absorber

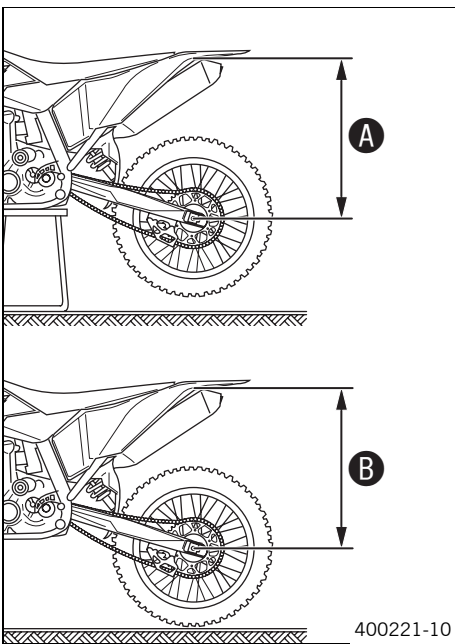

- Measure distance **A** of rear wheel unloaded. (☞ p. 21)
- Ask someone to help you by holding the motorcycle upright.
- Measure the distance between the rear axle and the fixed point again.
- Make a note of the value as measurement **B**.



**Info**

The static sag is the difference between measurements **A** and **B**.

- Check the static sag.

Static sag	12 mm (0.47 in)
------------	-----------------

- » If the static sag is less or more than the specified value:
  - Adjust the spring preload of the shock absorber. ☞ (☞ p. 22)

### Checking the riding sag of the shock absorber

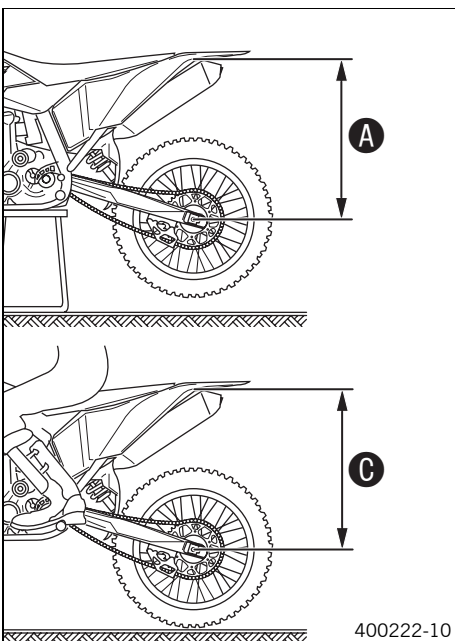

- Measure distance **A** of rear wheel unloaded. (☞ p. 21)
- Hold the motorcycle in a vertical position and seat the rider, wearing a full set of protective clothing, on the motorcycle in the normal sitting position (feet on the footrests). The rider should bounce up and down several times so that the rear wheel suspension can level out.
- Now measure the distance between the rear axle and the fixed point again.
- Make a note of the value as measurement **C**.



**Info**

The riding sag is the difference between measurements **A** and **C**.

- Check the riding sag.

Riding sag	90 mm (3.54 in)
------------	-----------------

- » If the riding sag differs from the specified measurement:
  - Adjust the riding sag. ☞ (☞ p. 22)

## Adjusting the spring preload of the shock absorber 🛠️

- Danger**  
**Danger of accidents** Disassembly of pressurized parts can lead to injury.
- The shock absorber is filled with high density nitrogen. Adhere to the description provided. (Your authorized KTM workshop will be glad to help.)

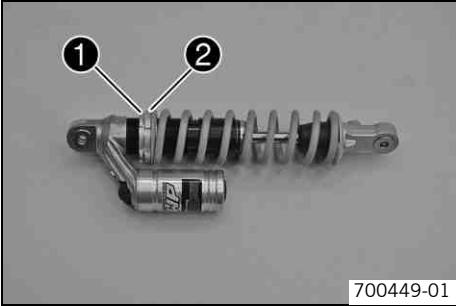

- Remove shock absorber. 🛠️ (📄 p. 23)
- After removing the shock absorber, clean it thoroughly.
- Measure the full spring length while it is under tension and note down the value.
- Loosen lock ring ❶.
- Turn adjusting ring ❷ until the spring is no longer under tension.

Combination wrench (50329080000)
Hook wrench (T106S)

- Measure the overall spring length when not under tension.
- Tighten the spring by turning adjusting ring ❷ to measurement.

**Guideline**

Spring preload	
Comfort	7 mm (0.28 in)
Standard	7 mm (0.28 in)
Sport	7 mm (0.28 in)

**i Info**  
 The spring preload is the difference between the relaxed spring length and the tensioned spring length.  
 Depending on the static sag and/or the riding sag, it may be necessary to increase or decrease the spring preload.

- Tighten lock ring ❶.
- Install the shock absorber. 🛠️ (📄 p. 23)

## Adjusting the riding sag 🛠️

- Remove shock absorber. 🛠️ (📄 p. 23)
- After removing the shock absorber, clean it thoroughly.
- Choose and mount a suitable spring.

**Guideline**

Spring rate	
Weight of rider: < 35 kg (< 77 lb.)	35 N/mm (200 lb/in)
Weight of rider: 35... 45 kg (77... 99 lb.)	40 N/mm (228 lb/in)
Weight of rider: > 45 kg (> 99 lb.)	45 N/mm (257 lb/in)

**i Info**  
 The spring rate is shown on the outside of the spring.  
 Smaller weight differences can be compensated by changing the spring preload.

- Install the shock absorber. 🛠️ (📄 p. 23)
- Check the static sag of the shock absorber. (📄 p. 21)
- Check the riding sag of the shock absorber. (📄 p. 21)
- Adjust the rebound damping of the shock absorber. (📄 p. 20)



## Removing the shock absorber ↩

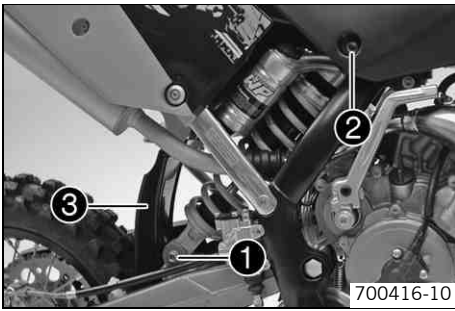

- Jack up the motorcycle. (↩ p. 20)
- Remove screw ❶ and lower the rear wheel with the swing arm as far as possible without blocking the rear wheel. Fix the rear wheel in this position.
- Remove screw ❷, push splash protector ❸ to the side, and remove the shock absorber.

## Installing shock absorber ↩

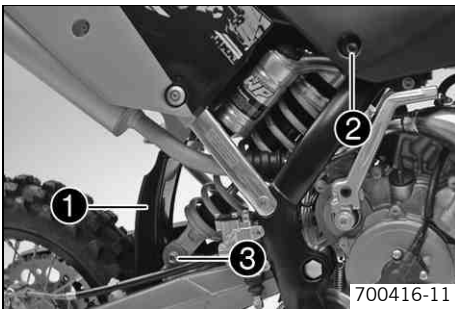

- Push splash protector ❶ to the side and position the shock absorber. Mount and tighten screw ❷.

Guideline

Screw, top shock absorber	M10	45 Nm (33.2 lbf ft)
---------------------------	-----	------------------------

- Mount and tighten screw ❸.

Guideline

Screw, bottom shock absorber	M10	45 Nm (33.2 lbf ft)
------------------------------	-----	------------------------

- Remove the motorcycle from the work stand. (↩ p. 20)

## Adjusting the compression damping of the fork



### Info

The hydraulic compression damping determines the fork suspension behavior.

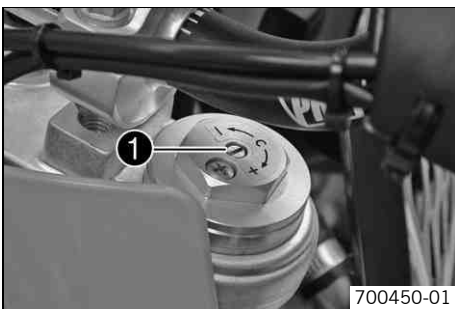

- Turn adjusting screw ❶ clockwise all the way.



### Info

Adjusting screw ❶ is located at the top end of the left fork leg and is labeled with a **C**.

- Turn back counterclockwise by the number of clicks corresponding to the fork type.

Guideline

Compression damping	
Standard	10 clicks



### Info

Turn clockwise to increase damping, turn counterclockwise to reduce suspension damping.

## Adjusting the rebound damping of the fork



### Info

The hydraulic rebound damping determines the fork suspension behavior.



- Turn adjusting screw ❶ clockwise all the way.



### Info

Adjusting screw ❶ is located at the top end of the right fork leg and is labeled with an **R**.

- Turn back counterclockwise by the number of clicks corresponding to the fork type.

Guideline

Rebound damping	
Standard	10 clicks



**Info**

Turn clockwise to increase damping, turn counterclockwise to reduce suspension damping.

## Vehicle level

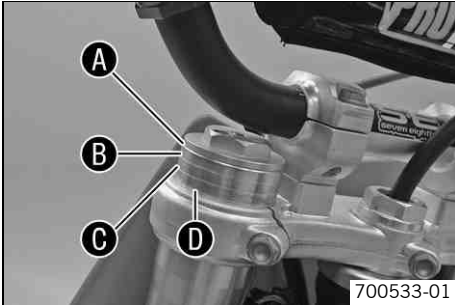

**Warning**

**Danger of accidents** Modifications to the suspension settings can seriously alter the vehicle's ride behavior.

- Following modifications, ride slowly at first to get the feel of the new ride behavior.

The vehicle level at the front can be adjusted via the fork legs clamp. The fork overhang can be individually adjusted to the size of the child. The fork should be pushed through no further than position **A**. Position **B** corresponds to the standard setting.

Upper triple clamp flush with top position	<b>A</b>
Upper triple clamp flush with 1st ring	<b>B</b> Standard
Upper triple clamp flush with 2nd ring	<b>C</b>
Upper triple clamp flush with 3rd ring	<b>D</b>

## Adjusting the fork overhang



**Warning**

**Danger of accidents** Modifications to the suspension settings can seriously alter the vehicle's ride behavior.

- Following modifications, ride slowly at first to get the feel of the new ride behavior.

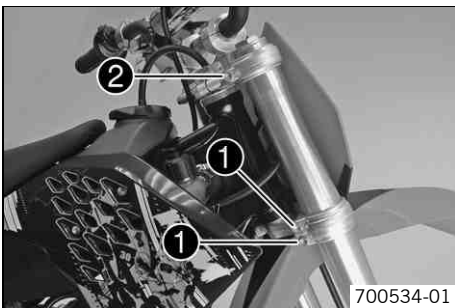

- Loosen screws **1** on the lower triple clamp.
- Loosen screw **2** on the upper triple clamp.



**Info**

Loosen the screws to the point where the fork leg can be moved without damaging it.

Make the adjustments first on one fork leg and then on the other.

- Adjust the fork overhang.

Guideline

Upper triple clamp flush with end of outer tube	<b>A</b>
Upper triple clamp flush with 1st ring	<b>B</b> Standard
Upper triple clamp flush with 2nd ring	<b>C</b>
Upper triple clamp flush with 3rd ring	<b>D</b>

- Tighten screw **2**.

Guideline

Screw, top triple clamp	M8	25 Nm (18.4 lbf ft)
-------------------------	----	------------------------

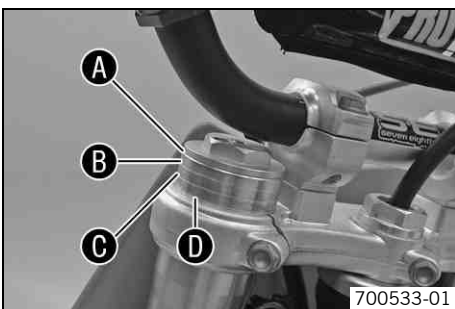

- Tighten screws ❶.

Guideline

Screw, bottom triple clamp	M8	25 Nm (18.4 lbf ft)
----------------------------	----	------------------------

- Repeat the adjustment on the other fork leg.



**Info**

The setting of the vehicle level via the fork legs must be identical on both fork legs.

## Bleeding fork legs

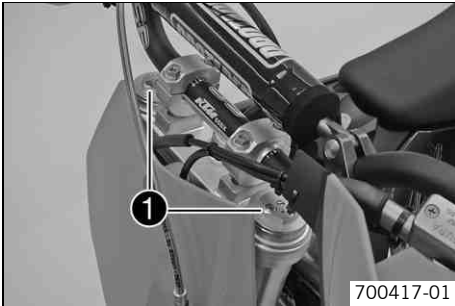

- Jack up the motorcycle. (☞ p. 20)
- Remove bleeder screws ❶ briefly.
- ✓ Any excess pressure escapes from the interior of the fork.
- Mount and tighten bleeder screws.
- Remove the motorcycle from the work stand. (☞ p. 20)

## Cleaning the dust boots of the fork legs

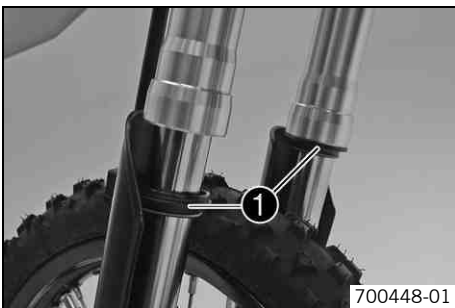

- Jack up the motorcycle. (☞ p. 20)
- Push dust boots ❶ of both fork legs downwards.



**Info**

The dust boots remove dust and coarse dirt particles from the fork tubes. Over time, dirt can penetrate behind the dust boots. If this dirt is not removed, the oil seals behind the boots can start to leak.



**Warning**

**Danger of accidents** Reduced braking efficiency due to oil or grease on the brake discs.

- Always keep the brake discs free of oil and grease, and clean them with brake cleaner when necessary.

- Clean and oil the dust boots and inner fork tube of both fork legs.

Universal oil spray (☞ p. 75)
-------------------------------

- Press the dust boots back into their normal position.
- Remove excess oil.
- Remove the motorcycle from the work stand. (☞ p. 20)

## Checking play of steering head bearing



**Warning**

**Danger of accidents** Unstable vehicle handling from incorrect steering head bearing play.

- Adjust the steering head bearing play without delay. (Your authorized KTM workshop will be glad to help.)



**Info**

If the bike is ridden for a longer time with play in the steering head bearing, the bearing and the bearing seats in the frame can be damaged after time.

- Jack up the motorcycle. (☞ p. 20)

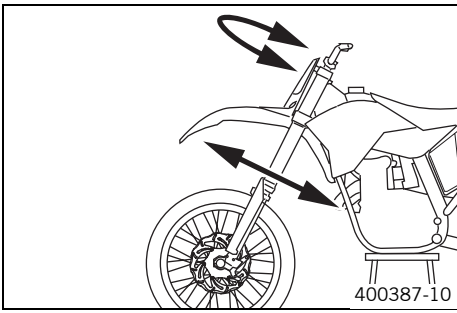

- Move the handlebar to the straight-ahead position. Move the fork legs to and fro in the direction of travel.

No play should be noticeable in the steering head bearing.

- » If there is noticeable play:
  - Adjust play of the steering head bearing. (🔧 p. 26)
- Move the handlebar to and fro over the entire steering range.

The handlebar must move smoothly over the entire steering range. There should be no perceptible detent positions.

- » If detent positions are noticeable:
  - Adjust play of the steering head bearing. (🔧 p. 26)
  - Check the steering head bearing and replace if required.
- Remove the motorcycle from the work stand. (🔧 p. 20)

## Adjusting play of steering head bearing 🛠️

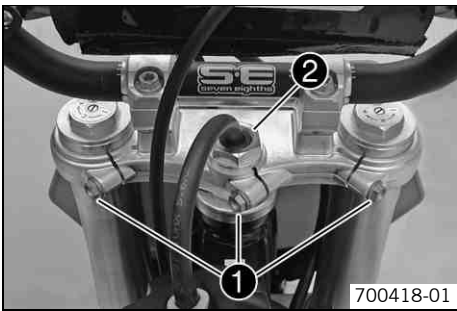

- Jack up the motorcycle. (🔧 p. 20)
- Loosen screw ❶.
- Loosen and retighten screw ❷.

Guideline

Nut, steering stem	M20x1.5	10 Nm (7.4 lbf ft)
--------------------	---------	--------------------

- Using a plastic hammer, tap lightly on the upper triple clamp to avoid strains.
- Fully tighten screw ❶.

Guideline

Screw, top triple clamp	M8	25 Nm (18.4 lbf ft)
-------------------------	----	---------------------

- Check play of steering head bearing. (🔧 p. 25)

## Removing the fork legs 🛠️

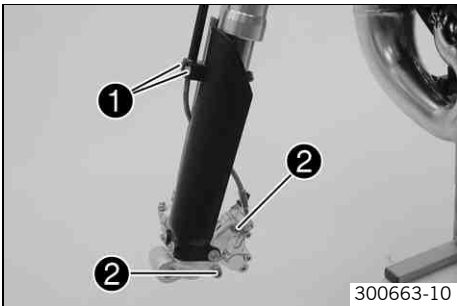

- Remove the front wheel. (🔧 p. 46)
- Remove screws ❶ and take off clamp.
- Remove screws ❷ and take off brake caliper.
- Hang the brake caliper and the brake line loosely to the side.



- Loosen screw ❸. Remove the left fork leg.
- Loosen screw ❹. Remove the right fork leg.

## Installing the fork legs



### Warning

**Danger of accidents** Modifications to the suspension settings can seriously alter the vehicle's ride behavior.

- Following modifications, ride slowly at first to get the feel of the new ride behavior.

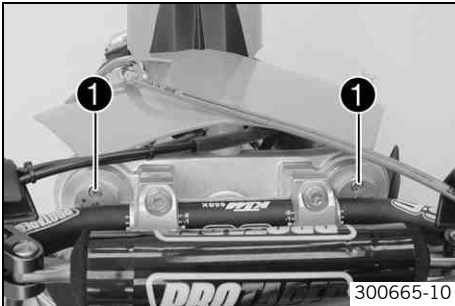

300665-10

- Position the fork legs.



### Info

Position the bleeder screw ❶ to the front.

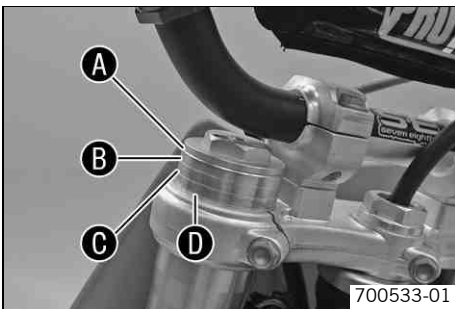

700533-01

- Adjust the fork overhang.

### Guideline

Upper triple clamp flush with end of outer tube	❶
Upper triple clamp flush with 1st ring	❷ Standard
Upper triple clamp flush with 2nd ring	❸
Upper triple clamp flush with 3rd ring	❹



### Info

The setting of the vehicle level via the fork legs must be identical on both fork legs.



300664-11

- Tighten screws ❷.

### Guideline

Screw, top triple clamp	M8	25 Nm (18.4 lbf ft)
-------------------------	----	------------------------

- Tighten screws ❸.

### Guideline

Screw, bottom triple clamp	M8	25 Nm (18.4 lbf ft)
----------------------------	----	------------------------

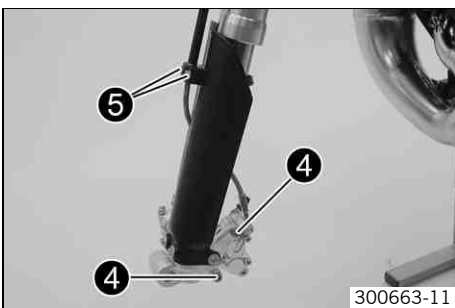

300663-11

- Position brake caliper, mount and tighten screws ❹.

### Guideline

Screw, brake caliper	M8	20 Nm (14.8 lbf ft)	Loctite® 243™
----------------------	----	------------------------	---------------

- Position the brake line. Mount the clamp and screws ❺.
- Install the front wheel. (🔧 p. 47)

## Removing the fork protector

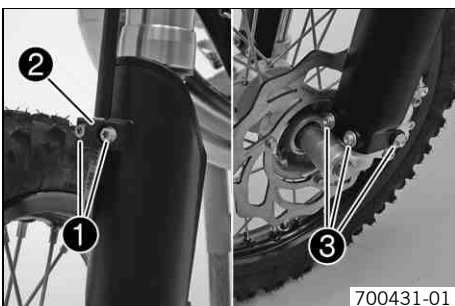

700431-01

- Remove screws ❶. Take off clamp ❷.
- Remove screw ❸ on the left fork leg. Take off the fork protector.

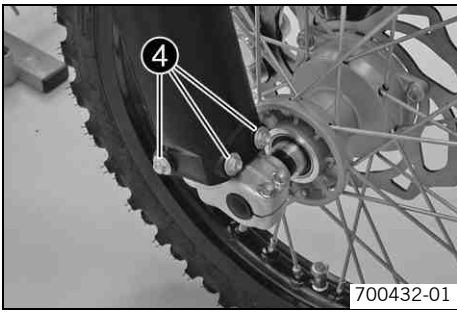

- Remove screw 4 on the right fork leg. Take off the fork protector.

## Installing the fork protector

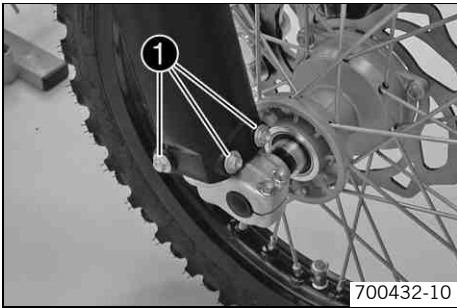

- Position the fork protection on the right fork leg. Mount and tighten screws 1.

Guideline

Remaining screws, chassis	M6	10 Nm (7.4 lbf ft)
---------------------------	----	--------------------

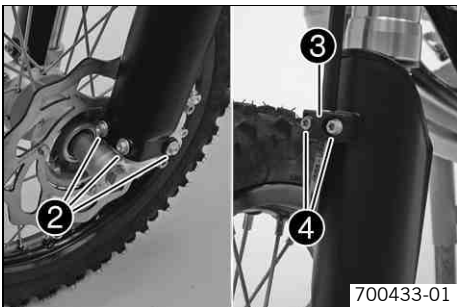

- Position the fork protection on the left fork leg. Mount and tighten screws 2.

Guideline

Remaining screws, chassis	M6	10 Nm (7.4 lbf ft)
---------------------------	----	--------------------

- Position the brake line. Mount clamp 3.
- Mount the screws 4.

## Removing the lower triple clamp

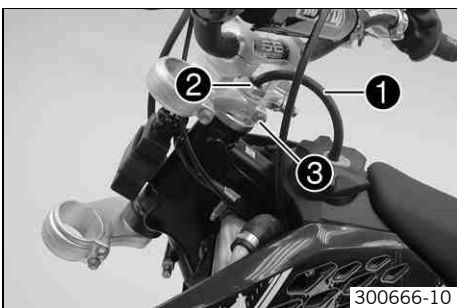

- Remove the fork legs. (p. 26)
- Dismount the start number plate. (p. 30)
- Dismount the front fender. (p. 30)
- Remove fuel tank breather 1.
- Remove screw 2. Remove screw 3, take off top triple clamp with the handlebar and place it on one side.

**i Info**  
Protect the motorcycle and its attachments from damage by covering them. Do not bend the cables and lines.

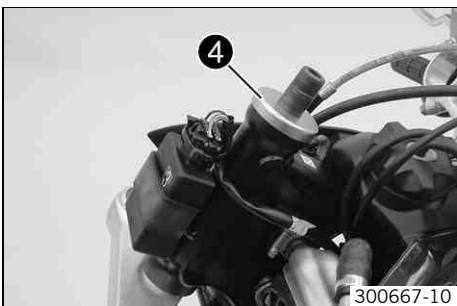

- Remove protector ring 4.
- Remove the lower triple clamp with the steering stem.
- Remove the upper steering head bearing.

## Installing the lower triple clamp

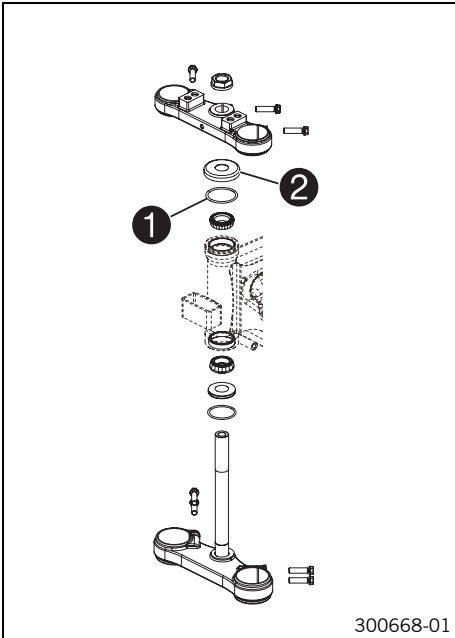

300668-01

- Clean the bearing and sealing elements, check for damage, and grease.

Long-life grease (☛ p. 74)

- Insert the lower triple clamp with the steering stem. Mount the upper steering head bearing.

**i Info**

Check whether the top steering head seal ❶ is correctly positioned.

- Push on protective ring ❷.

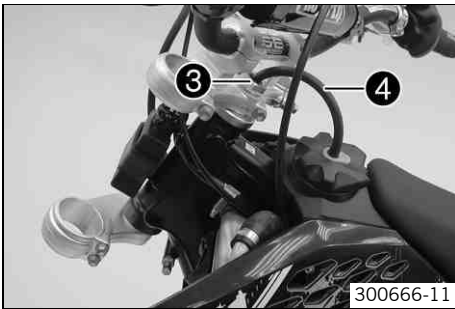

300666-11

- Position the upper triple clamp with the steering.
- Mount and tighten screw ❸.

Guideline

Nut, steering stem	M20x1.5	10 Nm (7.4 lbf ft)
--------------------	---------	--------------------

- Position fuel tank breather ❹.
- Install the front fender. (☛ p. 30)
- Install the start number plate. (☛ p. 30)
- Install the fork legs. ☛ (☛ p. 27)

- Mount and tighten screw ❺.

Guideline

Screw, top triple clamp	M8	25 Nm (18.4 lbf ft)
-------------------------	----	------------------------

- Check that the cable harness, throttle cables, brake and clutch line can move freely and are routed correctly.
- Check play of steering head bearing. (☛ p. 25)

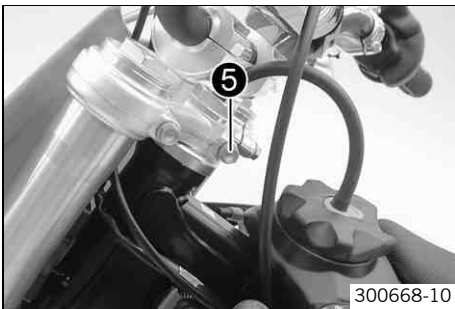

300668-10

## Greasing the steering head bearing

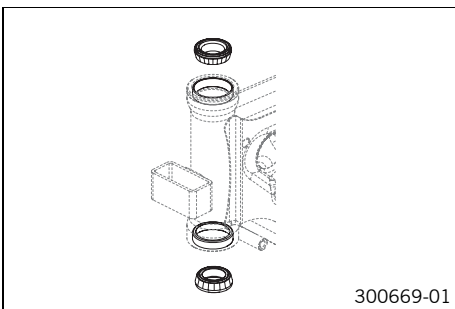

300669-01

- Remove the lower triple clamp. ☛ (☛ p. 28)
- Install the lower triple clamp. ☛ (☛ p. 29)

## Dismounting the front fender

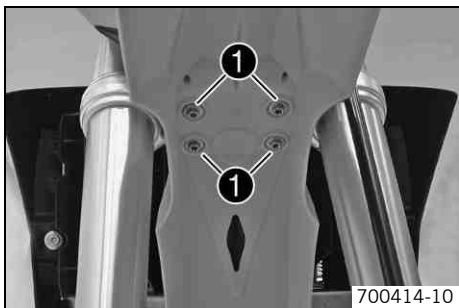

- Remove screws ❶. Remove the front fender.

## Installing the front fender

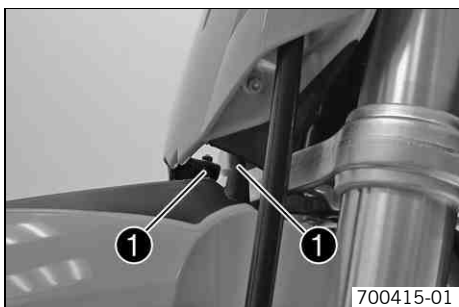

- Position the fender with holding lugs ❶ into the drill holes on the start number plate.

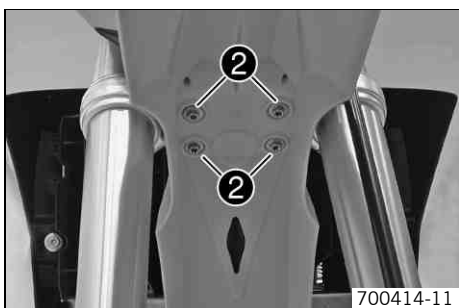

- Position the front fender. Mount and tighten screws ❷.

### Guideline

Remaining screws, chassis	M6	10 Nm (7.4 lbf ft)
---------------------------	----	--------------------

## Dismounting the start number plate

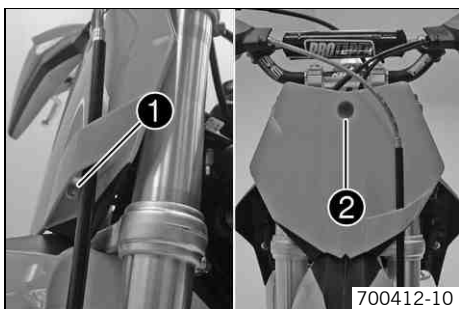

- Remove screw ❶ and take off clamp.
- Remove screw ❷. Remove the start number plate.

## Installing the start number plate



- Position the start number plate with the drill holes onto the holding lugs ❶ of the fender.



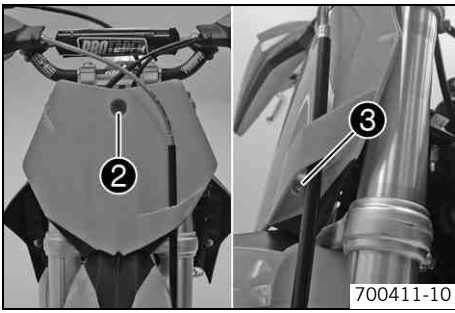

- Mount and tighten screw ❷.

Guideline

Remaining screws, chassis	M6	10 Nm (7.4 lbf ft)
---------------------------	----	--------------------

- Position the brake line. Put the clamp on, mount and tighten screw ❸.

## Handlebar position

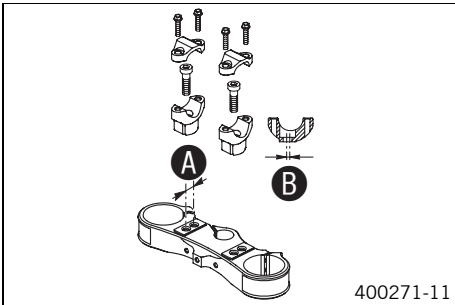

On the upper triple clamp, there are 2 holes at a distance of **A** to each other.

Distance <b>A</b> between holes	15 mm (0.59 in)
---------------------------------	-----------------

The holes on the handlebar support are placed at a distance of **B** from the center.

Distance <b>B</b> between holes	3.5 mm (0.138 in)
---------------------------------	-------------------

The handlebar supports can be mounted in 4 different positions.

## Adjusting handlebar position



### Warning

**Danger of accidents** Handlebar breakage.

- If the handlebar is bent or straightened it will cause material fatigue, and the handlebar can break. Always replace handlebar.

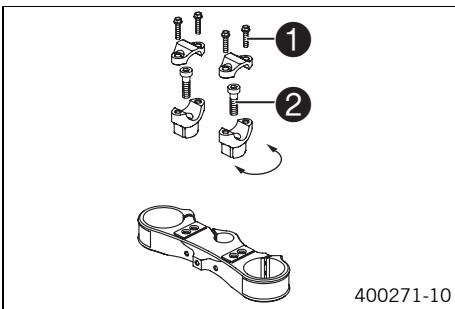

- Remove the four screws ❶. Remove the handlebar clamp. Remove the handlebar and lay it to one side.



### Info

Protect the motorcycle and its attachments from damage by covering them. Do not bend the cables and lines.

- Remove the two screws ❷. Remove the handlebar support.
- Place the handlebar support in the required position. Mount and tighten the two screws ❷.

Guideline

Screw, handlebar support	M10	40 Nm (29.5 lbf ft)	Loctite® 243™
--------------------------	-----	---------------------	---------------

- Position the handlebar.



### Info

Make sure cables and wiring are positioned correctly.

- Position the handlebar clamp. Mount and evenly tighten the four screws ❶.

Guideline

Screw, handlebar clamp	M8	20 Nm (14.8 lbf ft)
------------------------	----	---------------------



### Info

Make sure the gap width is even.

## Checking the play in the throttle cable

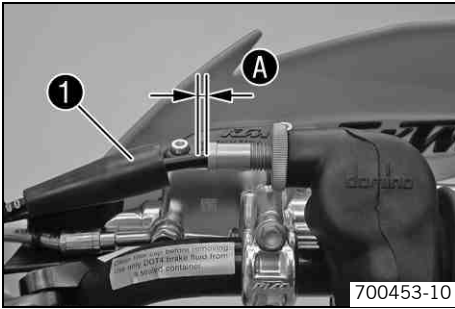

- Move the handlebar to the straight-ahead position.
- Push back bellows ❶.
- Pull back the throttle cable casing until you sense a resistance.
- Now check throttle cable play ❷.

Play in gas throttle cable	3... 5 mm (0.12... 0.2 in)
----------------------------	----------------------------

- » If the throttle cable play does not meet specifications:
  - Adjust the play in the throttle cable. (🔧 p. 32)
- Push on bellows ❶. Check the throttle grip for smooth operation.

## Adjusting the play in the throttle cable 🔧

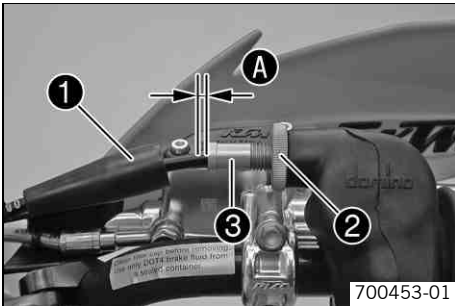

- Move the handlebar to the straight-ahead position.
- Push back bellows ❶.
- Loosen nut ❷. Turn adjusting screw ❸ in as far as possible.
- Turn the adjusting screw so that there is play ❷ at the outer casing of the throttle cable.

Guideline

Play in gas throttle cable	3... 5 mm (0.12... 0.2 in)
----------------------------	----------------------------

- Tighten the nut.
- Push on bellows ❶. Check the throttle grip for smooth operation.

## Checking chain dirt

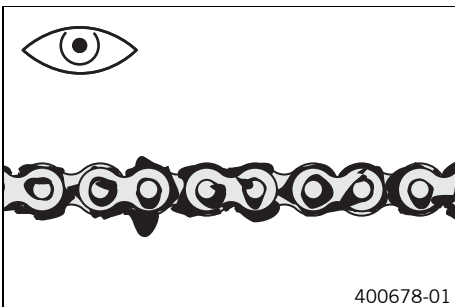

- Check the chain for coarse dirt accumulation.
  - » If the chain is very dirty:
    - Clean the chain. (🔧 p. 32)

## Cleaning the chain

**Warning**  
**Danger of accidents** Oil or grease on the tires reduces their grip.  
 - Remove oil and grease with a suitable cleaning material.

**Warning**  
**Danger of accidents** Reduced braking efficiency due to oil or grease on the brake discs.  
 - Always keep the brake discs free of oil and grease, and clean them with brake cleaner when necessary.

**Warning**  
**Environmental hazard** Hazardous substances cause environmental damage.  
 - Oil, grease, filters, fuel, cleaners, brake fluid, etc., should be disposed of as stipulated in applicable regulations.

**i Info**  
 The service life of the chain depends largely on its maintenance.

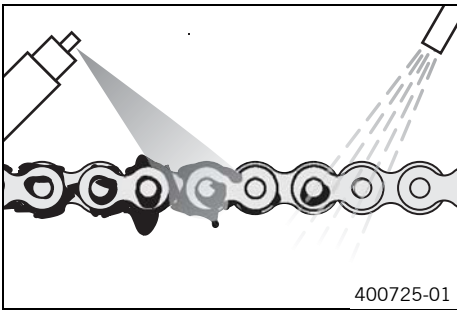

- Clean the chain regularly and then treat with chain spray.

Chain cleaner (☞ p. 74)

Offroad chain spray (☞ p. 74)

## Removing the chain guard 🛠️

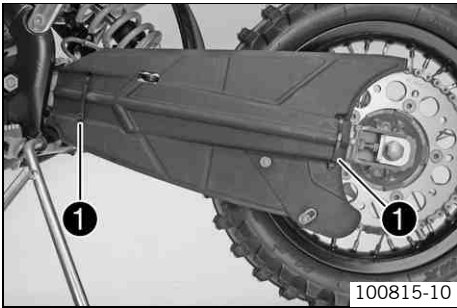

- Remove cable binder ❶.
- Take off the chain guard.

## Installing the chain guard

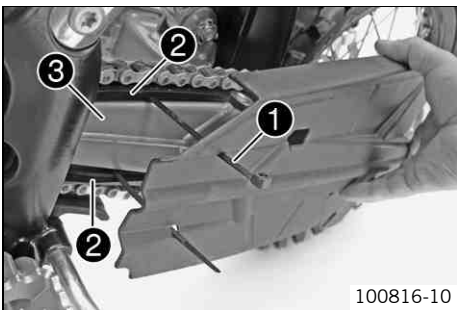

- Position the chain guard. Mount cable binder ❶.

### **i** Info

The cable binder must be run between chain sliding guard ❷ and swingarm ❸.

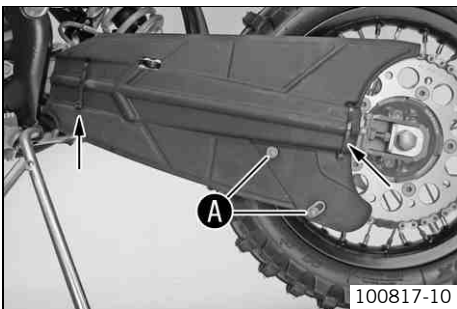

- Mount the cable binder at the rear.
- Align the chain guard so that screws **A** of the chain guide are visible.
- Tighten the cable binder and cut off the ends.

## Checking the chain tension

### **!** Warning

**Danger of accidents** Danger caused by incorrect chain tension.

- If the chain is over tensioned, the components of the secondary power train (chain, engine sprocket, rear sprocket, bearings in transmission and rear wheel) are under additional load. Apart from premature wear, in extreme cases the chain may snap or the countershaft of the transmission can break. On the other hand, if the chain is loose, it may jump off the engine sprocket or the rear sprocket, causing the rear wheel to lock or damage the engine. Check for correct chain tension and adjust if necessary.

- Remove the chain guard. 🛠️ (☞ p. 33)
- Jack up the motorcycle. (☞ p. 20)

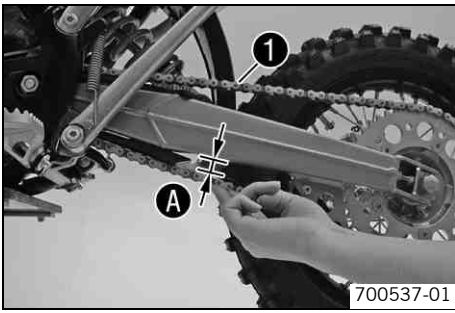

- Push the chain at the end of the chain sliding component upward to measure the chain tension **A**.



**Info**

The upper chain section **1** must be taut. Because chain wear is not always even, repeat this measurement at different chain positions.

Chain tension	5... 8 mm (0.2... 0.31 in)
---------------	----------------------------

- » If the chain tension does not meet specifications:
  - Adjusting chain tension - after checking. (☛ p. 35)
- Install the chain guard. (☛ p. 33)
- Remove the motorcycle from the work stand. (☛ p. 20)

## Checking the chain tension - installing rear wheel



**Warning**

**Danger of accidents** Danger caused by incorrect chain tension.

- If the chain is over tensioned, the components of the secondary power train (chain, engine sprocket, rear sprocket, bearings in transmission and rear wheel) are under additional load. Apart from premature wear, in extreme cases the chain may snap or the countershaft of the transmission can break. On the other hand, if the chain is loose, it may jump off the engine sprocket or the rear sprocket, causing the rear wheel to lock or damage the engine. Check for correct chain tension and adjust if necessary.

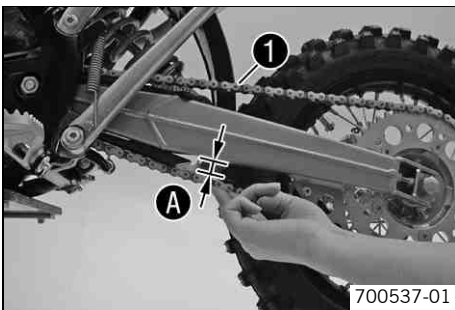

- Make sure that the chain adjusters are fitted correctly on the adjusting screws.
- Push the chain at the end of the chain sliding component upward to measure the chain tension **A**.



**Info**

The upper chain section **1** must be taut. Because chain wear is not always even, repeat this measurement at different chain positions.

Chain tension	5... 8 mm (0.2... 0.31 in)
---------------	----------------------------

- » If the chain tension does not meet specifications:
  - Adjust the chain tension when installing the rear wheel. (☛ p. 35)

## Checking rear sprocket / engine sprocket for wear

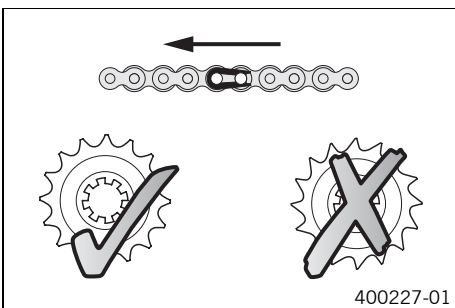

- Check rear sprocket / engine sprocket for wear.
  - » If the rear sprocket / engine sprocket are worn:
    - Replace rear sprocket / engine sprocket.



**Info**

When fitting the chain joint, always make sure that the closed side of the joint faces forward (riding direction). The engine sprocket, rear sprocket and chain should always be replaced together.

- Check the chain guide for tightness and wear.

## Adjusting the chain tension



**Warning**

**Danger of accidents** Danger caused by incorrect chain tension.

- If the chain is over tensioned, the components of the secondary power train (chain, engine sprocket, rear sprocket, bearings in transmission and rear wheel) are under additional load. Apart from premature wear, in extreme cases the chain may snap or the countershaft of the transmission can break. On the other hand, if the chain is loose, it may jump off the engine sprocket or the rear sprocket, causing the rear wheel to lock or damage the engine. Check for correct chain tension and adjust if necessary.

- Jack up the motorcycle. (☛ p. 20)
- Remove the chain guard. ☛ (☛ p. 33)

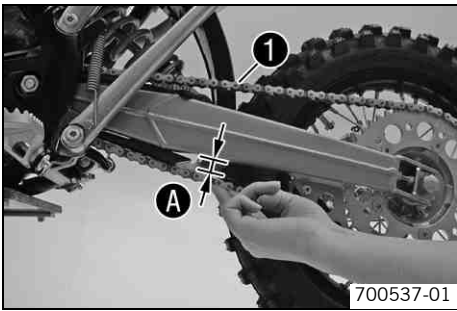

- Push the chain at the end of the chain sliding component upward to measure the chain tension **A**.



**Info**

The upper chain section **1** must be taut.  
Because chain wear is not always even, repeat this measurement at different chain positions.

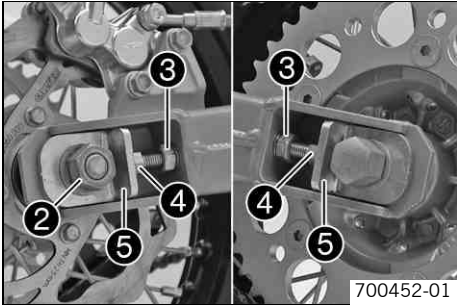

- Loosen nut **2**.
- Loosen nuts **3**.
- Adjust the chain tension by turning the adjusting screws **4** to the left and right.

Guideline

Chain tension	5... 8 mm (0.2... 0.31 in)
Turn adjusting screws <b>4</b> equally on the left and right. Check that the rear wheel is aligned with the front wheel.	

- Tighten nuts **3**.
- Make sure that chain adjusters **5** are fitted correctly on adjusting screws **4**.
- Tighten nut **2**.

Guideline

Nut, rear wheel spindle	M12x1	40 Nm (29.5 lbf ft)
-------------------------	-------	------------------------

- Install the chain guard. (☛ p. 33)
- Remove the motorcycle from the work stand. (☛ p. 20)

### Adjusting chain tension - after checking

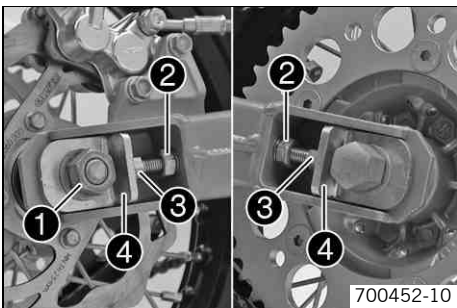

- Loosen nut **1**.
- Loosen nuts **2**.
- Adjust the chain tension by turning the adjusting screws **3** left and right.

Guideline

Chain tension	5... 8 mm (0.2... 0.31 in)
Turn adjusting screws <b>3</b> equally on the left and right. Check that the rear wheel is aligned with the front wheel.	

- Tighten nuts **2**.
- Make sure that the chain adjusters **4** are fitted correctly on the adjusting screws **3**.
- Tighten nut **1**.

Guideline

Nut, rear wheel spindle	M12x1	40 Nm (29.5 lbf ft)
-------------------------	-------	------------------------

### Adjusting chain tension - installing rear wheel

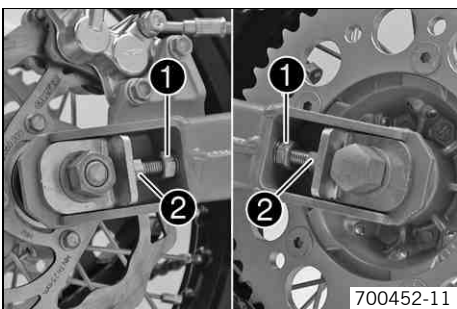

- Loosen nuts **1**.
- Adjust the chain tension by turning the adjusting screws **2** left and right.

Guideline

Chain tension	5... 8 mm (0.2... 0.31 in)
Turn adjusting screws <b>2</b> equally on the left and right. Check that the rear wheel is aligned with the front wheel.	

- Tighten nuts **1**.

## Adjusting the chain guide

**i Info**  
The size of the chain wheel varies with the number of teeth. The chain guide can be adjusted on small sprockets.

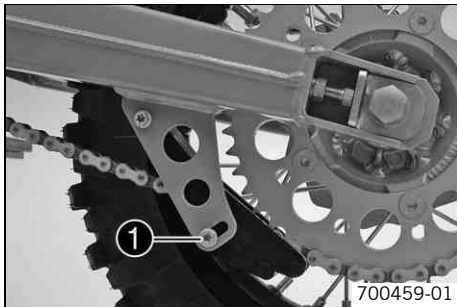

- Remove the chain guard. (☞ p. 33)
- Loosen screw ❶.
- Position the chain guide.
- Tighten screw.

**Guideline**

Remaining screws, chassis	M6	10 Nm (7.4 lbf ft)
---------------------------	----	--------------------

- Install the chain guard. (☞ p. 33)

## Adjusting basic position of clutch lever



- Adjust the basic setting of the clutch lever to the size of your child's hand by turning the adjusting screw ❶.

**i Info**  
Turn the adjusting screw clockwise to increase the distance between the clutch lever and the handlebar.  
Turn the adjusting screw counterclockwise to decrease the distance between the clutch lever and the handlebar.  
The range of adjustment is limited.  
Turn the adjusting screw by hand only, and do not apply any force.  
Do not make any adjustments while riding!

## Checking the fluid level of hydraulic clutch

**i Info**  
The fluid level rises with increasing wear of the clutch lining disc.  
Do not use brake fluid.

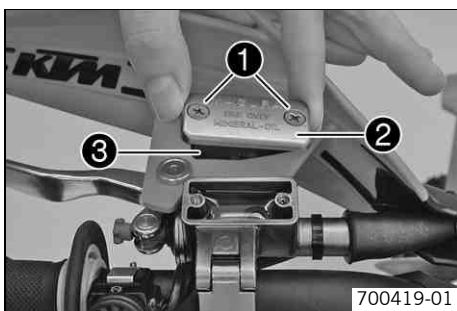

- Move the clutch fluid reservoir mounted on the handlebar to a horizontal position.
- Remove screws ❶.
- Remove cover ❷ with diaphragm ❸.
- Check the fluid level.

Fluid level under top level of container	4 mm (0.16 in)
--	----------------

- » If the level of the fluid does not meet specifications:
  - Correct the fluid level of the hydraulic clutch.

Hydraulic fluid (15) (☞ p. 72)
--------------------------------

- Position the cover with the diaphragm. Mount and tighten the screws.

## Changing the hydraulic clutch fluid

**Warning**  
**Environmental hazard** Hazardous substances cause environmental damage.

- Oil, grease, filters, fuel, cleaners, brake fluid, etc., should be disposed of as stipulated in applicable regulations.

**i Info**  
The fluid level rises with increasing wear of the clutch lining disc.

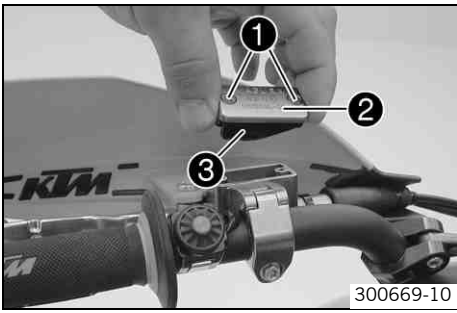

- Move the clutch fluid reservoir mounted on the handlebar to a horizontal position.
- Remove screws 1.
- Remove cover 2 with diaphragm 3.

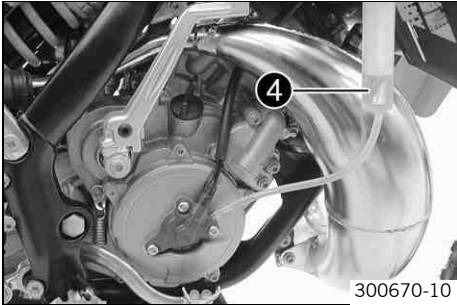

- Fill bleeding syringe 4 with the appropriate hydraulic fluid.

Bleed syringe (50329050000)
-----------------------------

Hydraulic fluid (15) (☛ p. 72)
--------------------------------

- On the slave cylinder, remove the bleeder screw and mount bleeding syringe 4.

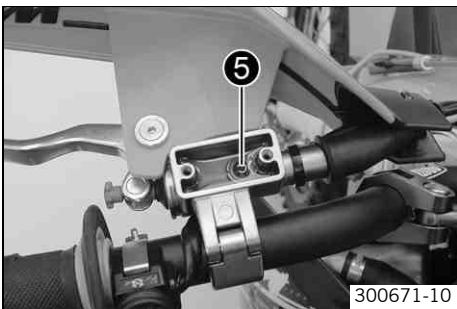

- Inject the liquid into the system until it escapes from drill hole 5 of the master cylinder without bubbles.
- To prevent overflow, drain fluid occasionally from the master cylinder reservoir.
- Remove the bleeding syringe. Mount and tighten screws bleeder screw.
- Correct the fluid level of the hydraulic clutch.

Guideline

Fluid level under top level of container	4 mm (0.16 in)
--	----------------

- Position the cover with the diaphragm. Mount and tighten the screws.

## Checking brake discs



**Warning**

**Danger of accidents** Reduced braking efficiency due to worn brake disc(s).

- Change the worn brake disc(s) without delay. (Your authorized KTM workshop will be glad to help.)

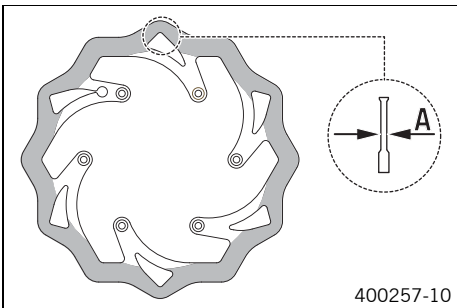

- Check the thickness of the front and rear brake discs at several places on the disc to see if it conforms to measurement A.

**Info**

Wear reduces the thickness of the brake disc around the area used by the brake linings.

Brake discs - wear limits

Front	2.5 mm (0.098 in)
Rear	2.5 mm (0.098 in)

- » If the brake disc thickness is less than the specified value:
  - Change the brake disc.
- Check the front and rear brake discs for damage, cracking and deformation.
  - » If the brake disk exhibits damage, cracking or deformation:
    - Change the brake disc.

## Checking free play of hand brake lever

- Warning**  
**Danger of accidents** Brake system failure.
- If there is no free travel on the hand brake lever, pressure builds up on the front brake in the brake system. The front brake can fail due to overheating. Adjust free travel on hand brake lever according to specifications.



- Push the hand brake lever forwards and check free play **A**.

Free play of hand brake lever	$\geq 3 \text{ mm } (\geq 0.12 \text{ in})$
-------------------------------	---

- » If the free travel does not meet specifications:
  - Adjust the basic position of the handbrake lever. (☛ p. 38)

## Adjusting basic position of handbrake lever



- Check the free play of the hand brake lever. (☛ p. 38)
- Adjust the basic setting of the hand brake lever to the size of your child's hand by turning adjusting screw **1**.

**i Info**  
 Turn the adjusting screw clockwise to increase the distance between the handbrake lever and the handlebar.  
 Turn the adjusting screw counterclockwise to decrease the distance between the handbrake lever and the handlebar.  
 The range of adjustment is limited.  
 Turn the adjusting screw by hand only, and do not apply any force.  
 Do not make any adjustments while riding!

## Checking the front brake fluid level

- Warning**  
**Danger of accidents** Brake system failure.
- If the brake fluid level drops below the specified marking or the specified value, this is an indication that the brake system is leaking or that the brake linings are completely worn down. Check the brake system and do not continue riding. (Your authorized KTM workshop will be glad to help.)

- Warning**  
**Skin irritation** Brake fluid can cause skin irritation on contact.
- Avoid contact with skin and eyes, and keep out of the reach of children.
  - Wear suitable protective clothing and goggles.
  - If brake fluid gets into your eyes, rinse thoroughly with water and contact a doctor immediately.

- Warning**  
**Danger of accidents** Reduced braking efficiency due to old brake fluid.
- Change the brake fluid of the front and rear brakes according to the service schedule. (Your authorized KTM workshop will be glad to help.)

- Warning**  
**Environmental hazard** Hazardous substances cause environmental damage.
- Oil, grease, filters, fuel, cleaners, brake fluid, etc., should be disposed of as stipulated in applicable regulations.

**i Info**  
 Never use DOT 5 brake fluid! This is based on silicone oil and is colored purple. Oil seals and brake lines are not designed for DOT 5 brake fluid.  
 Avoid contact between brake fluid and painted parts. Brake fluid attacks paint!  
 Use only clean brake fluid from a sealed container!



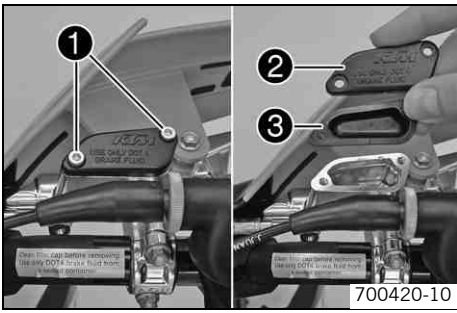

- Move the brake fluid reservoir mounted on the handlebar to a horizontal position.
- Remove screws ❶.
- Remove cover ❷ with diaphragm ❸.
- Check the brake fluid level.

Brake fluid level under top level of container	5 mm (0.2 in)
--	---------------

- » If the brake fluid level does not meet specifications:
  - Add front brake fluid. 🛠️ (👉 p. 39)
- Position the cover with the diaphragm. Mount and tighten the screws.

**i Info**  
Clean up overflowed or spilt brake fluid immediately with water.

## Adding front brake fluid 🛠️

**⚠ Warning**  
**Danger of accidents** Brake system failure.

- If the brake fluid level drops below the specified marking or the specified value, this is an indication that the brake system is leaking or that the brake linings are completely worn down. Check the brake system and do not continue riding. (Your authorized KTM workshop will be glad to help.)

**⚠ Warning**  
**Skin irritation** Brake fluid can cause skin irritation on contact.

- Avoid contact with skin and eyes, and keep out of the reach of children.
- Wear suitable protective clothing and goggles.
- If brake fluid gets into your eyes, rinse thoroughly with water and contact a doctor immediately.

**⚠ Warning**  
**Danger of accidents** Reduced braking efficiency due to old brake fluid.

- Change the brake fluid of the front and rear brakes according to the service schedule. (Your authorized KTM workshop will be glad to help.)

**🌸 Warning**  
**Environmental hazard** Hazardous substances cause environmental damage.

- Oil, grease, filters, fuel, cleaners, brake fluid, etc., should be disposed of as stipulated in applicable regulations.

**i Info**  
Never use DOT 5 brake fluid! This is based on silicone oil and is colored purple. Oil seals and brake lines are not designed for DOT 5 brake fluid.  
Avoid contact between brake fluid and painted parts. Brake fluid attacks paint!  
Use only clean brake fluid from a sealed container!

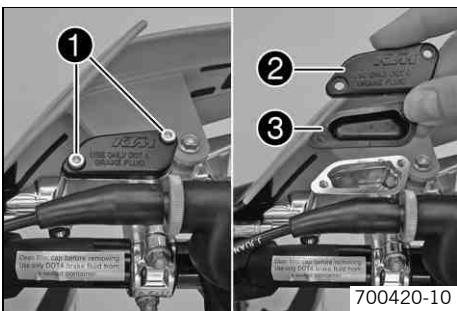

- Move the brake fluid reservoir mounted on the handlebar to a horizontal position.
- Remove screws ❶.
- Remove cover ❷ with diaphragm ❸.
- Correct the brake fluid level.

Guideline

Brake fluid level under top level of container	5 mm (0.2 in)
--	---------------

Brake fluid DOT 4 / DOT 5.1 (👉 p. 72)
---------------------------------------

- Position the cover with the diaphragm. Mount and tighten the screws.

**i Info**  
Clean up overflowed or spilt brake fluid immediately with water.

## Checking the front brake linings



### Warning

**Danger of accidents** Reduced braking efficiency caused by worn brake linings.

- Change worn brake linings immediately. (Your authorized KTM workshop will be glad to help.)

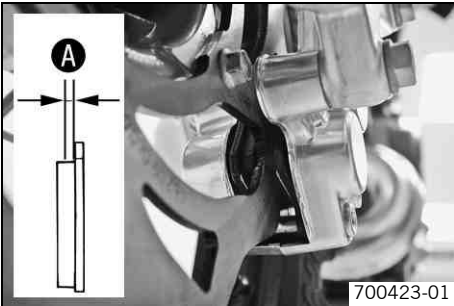

700423-01

- Check the brake linings for minimum thickness **A**.

Minimum thickness <b>A</b>	$\geq 1 \text{ mm } (\geq 0.04 \text{ in})$
----------------------------	---

- » If the minimum thickness is less than specified:
  - Change the front brake linings. 🛠️ (📄 p. 41)
- Check the brake linings for damage and cracking.
  - » If damage or wear is encountered:
    - Change the front brake linings. 🛠️ (📄 p. 41)

## Removing front brake linings 🛠️



### Warning

**Danger of accident** Brake system failure.

- Maintenance work and repairs must be carried out professionally. (Your authorized KTM workshop will be glad to help.)

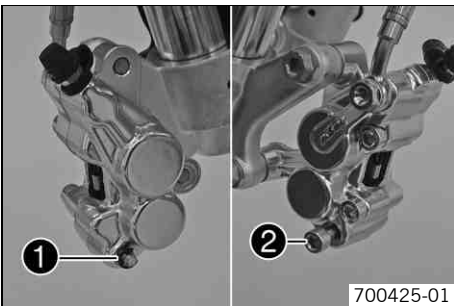

700425-01

- Remove the front wheel. 🛠️ (📄 p. 46)
- Remove the lock washer **1**.
- Remove screw **2**.

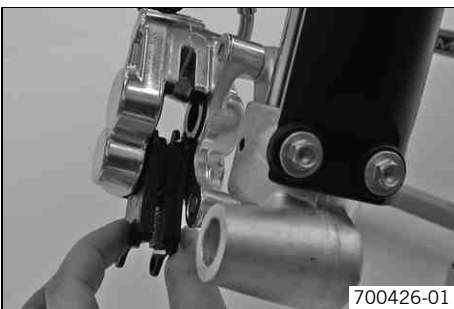

700426-01

- Remove the brake linings.
- Clean brake caliper and brake caliper support.

## Installing the front brake linings 🛠️



### Warning

**Danger of accidents** Reduced braking efficiency due to oil or grease on the brake discs.

- Always keep the brake discs free of oil and grease, and clean them with brake cleaner when necessary.



### Warning

**Danger of accidents** Reduced braking efficiency due to use of non-approved brake linings.

- Brake linings available from accessory suppliers are often not tested and approved for use on KTM vehicles. The construction and friction factor of the brake linings and therefore the brake power can differ considerably from the original KTM brake linings. If brake linings are used that differ from the originals, there is no guarantee that they comply with the original license. The vehicle no longer corresponds to the condition at delivery, and the warranty is no longer valid.

- Check the brake discs. (📄 p. 37)

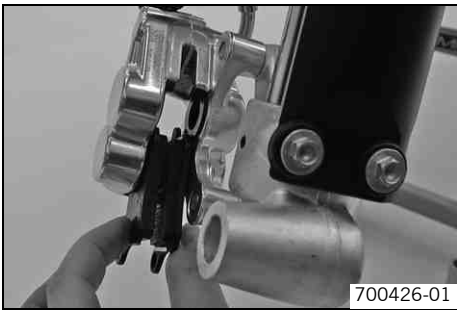

700426-01

- Insert the brake linings.

**i Info**

Ensure that the brake linings are correctly positioned in the holding spring.

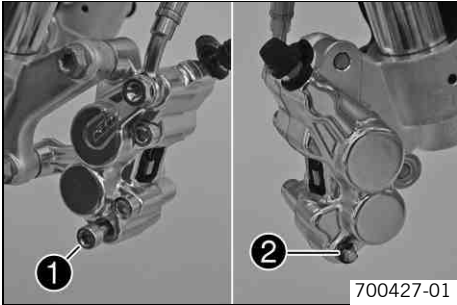

700427-01

- Mount and tighten screw ❶.
- Mount lock washer ❷.
- Install the front wheel. ↗ (☞ p. 47)

## Changing the front brake linings ↗



**Warning**

**Skin irritation** Brake fluid can cause skin irritation on contact.

- Avoid contact with skin and eyes, and keep out of the reach of children.
- Wear suitable protective clothing and goggles.
- If brake fluid gets into your eyes, rinse thoroughly with water and contact a doctor immediately.



**Warning**

**Danger of accidents** Reduced braking efficiency due to old brake fluid.

- Change the brake fluid of the front and rear brakes according to the service schedule. (Your authorized KTM workshop will be glad to help.)



**Warning**

**Environmental hazard** Hazardous substances cause environmental damage.

- Oil, grease, filters, fuel, cleaners, brake fluid, etc., should be disposed of as stipulated in applicable regulations.



**Info**

Never use DOT 5 brake fluid! This is based on silicone oil and is colored purple. Oil seals and brake lines are not designed for DOT 5 brake fluid.

Avoid contact between brake fluid and painted parts. Brake fluid attacks paint!

Use only clean brake fluid from a sealed container!

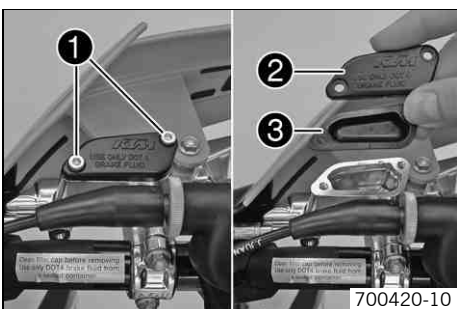

700420-10

- Remove the front brake linings. ↗ (☞ p. 40)
- Move the brake fluid reservoir mounted on the handlebar to a horizontal position.
- Remove screws ❶.
- Remove cover ❷ with diaphragm ❸.
- Press the brake piston back to its basic position and make sure that no brake fluid overflows from the brake fluid reservoir.
- Install the front brake linings. ↗ (☞ p. 40)
- Correct the brake fluid level.

**Guideline**

Brake fluid level under top level of container	5 mm (0.2 in)
--	---------------

Brake fluid DOT 4 / DOT 5.1 (☞ p. 72)	
---------------------------------------	--

- Position the cover with the diaphragm. Mount and tighten the screws.



**Info**

Clean up overflowed or spilt brake fluid immediately with water.

## Checking the free travel of the foot brake lever



**Warning**

**Danger of accidents** Brake system failure.

- If there is no free travel on the foot brake pedal, pressure builds up on the rear brake in the brake system. The rear brake can fail due to overheating. Adjust free travel on foot brake pedal according to specifications.

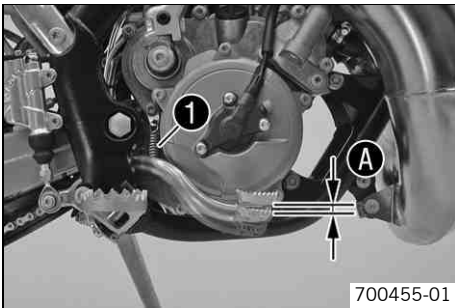

- Disconnect spring ❶.
- Move the foot brake lever backwards and forwards between the end stop and the foot brake cylinder piston bracket and check free travel ❷.

Guideline

Free play at foot brake lever	3... 5 mm (0.12... 0.2 in)
-------------------------------	----------------------------

- » If the free travel does not meet specifications:
  - Adjust the free travel of the foot brake pedal. 🛠️ (📄 p. 42)
- Attach spring ❶.

## Adjusting the free travel of the foot brake pedal 🛠️



**Warning**

**Danger of accidents** Brake system failure.

- If there is no free travel on the foot brake pedal, pressure builds up on the rear brake in the brake system. The rear brake can fail due to overheating. Adjust free travel on foot brake pedal according to specifications.

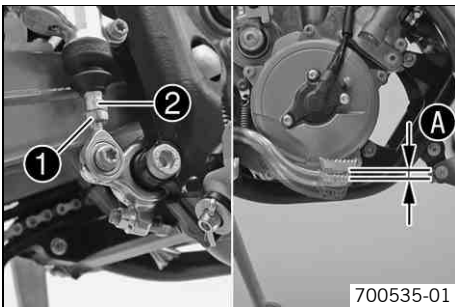

- Detach the spring.
- Loosen nut ❶.
- Turn push rod ❷ until clearance ❷ is created.

Guideline

Free play at foot brake lever	3... 5 mm (0.12... 0.2 in)
-------------------------------	----------------------------

- Hold push rod ❷ and tighten nut ❶.
- Attach the spring.
- Check whether the basic position of the foot brake pedal is suitable for the rider.
  - » If the basic position of the foot brake pedal needs to be adjusted:
    - Adjust the basic position of the foot brake pedal. 🛠️ (📄 p. 42)

## Adjusting the basic position of the foot brake pedal 🛠️



**Warning**

**Danger of accidents** Brake system failure.

- If there is no free travel on the foot brake pedal, pressure builds up on the rear brake in the brake system. The rear brake can fail due to overheating. Adjust free travel on foot brake pedal according to specifications.

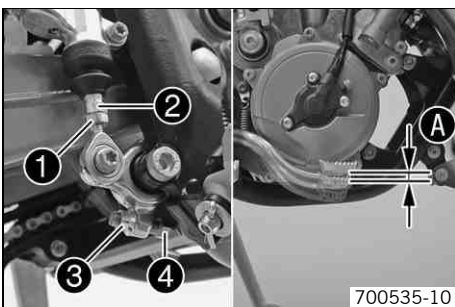

- Detach the spring.
- Loosen nut ❶.
- Turn back push rod ❷.
- Loosen nut ❸.
- To adjust the basic position of the foot brake lever, turn screw ❹ accordingly.



**Info**

The range of adjustment is limited.

- Hold screw ❹ and tighten nut ❸.

Guideline

Remaining nuts, chassis	M8	30 Nm (22.1 lbf ft)
-------------------------	----	------------------------

- Check the free travel of the foot brake lever. (☞ p. 42)

Guideline

Free play at foot brake lever	3... 5 mm (0.12... 0.2 in)
-------------------------------	----------------------------

- » If the free travel at the foot brake pedal does not meet specifications:
  - Adjust the free travel of the foot brake pedal. ☞ (☞ p. 42)
- Attach spring ❶.

## Checking rear brake fluid level



**Warning**

**Danger of accidents** Failure of the brake system.

- If the brake fluid level falls below the **MIN** mark, this indicates a leakage in the brake system or worn-out brake linings. Check the brake system and do not continue riding. (Your authorized KTM workshop will be glad to help.)



**Warning**

**Danger of accidents** Reduced braking efficiency due to old brake fluid.

- Change the brake fluid of the front and rear brakes according to the service schedule. (Your authorized KTM workshop will be glad to help.)

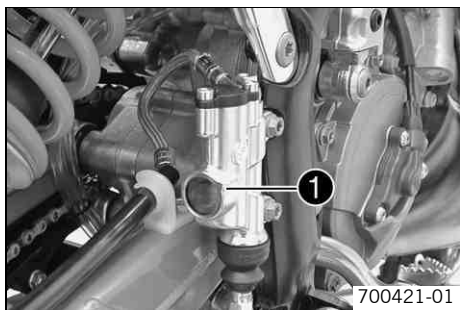

- Stand the vehicle upright.
- Check the brake fluid level in the viewer ❶.
  - » When an air bubble is visible in the viewer ❶:
    - Add rear brake fluid. ☞ (☞ p. 43)

## Adding rear brake fluid ☞



**Warning**

**Danger of accidents** Failure of the brake system.

- If the brake fluid level falls below the **MIN** mark, this indicates a leakage in the brake system or worn-out brake linings. Check the brake system and do not continue riding. (Your authorized KTM workshop will be glad to help.)



**Warning**

**Skin irritation** Brake fluid can cause skin irritation on contact.

- Avoid contact with skin and eyes, and keep out of the reach of children.
- Wear suitable protective clothing and goggles.
- If brake fluid gets into your eyes, rinse thoroughly with water and contact a doctor immediately.



**Warning**

**Danger of accidents** Reduced braking efficiency due to old brake fluid.

- Change the brake fluid of the front and rear brakes according to the service schedule. (Your authorized KTM workshop will be glad to help.)



**Warning**

**Environmental hazard** Hazardous substances cause environmental damage.

- Oil, grease, filters, fuel, cleaners, brake fluid, etc., should be disposed of as stipulated in applicable regulations.

**i Info**

Never use DOT 5 brake fluid! This is based on silicone oil and is colored purple. Oil seals and brake lines are not designed for DOT 5 brake fluid.  
 Avoid contact between brake fluid and painted parts. Brake fluid attacks paint!  
 Use only clean brake fluid from a sealed container!

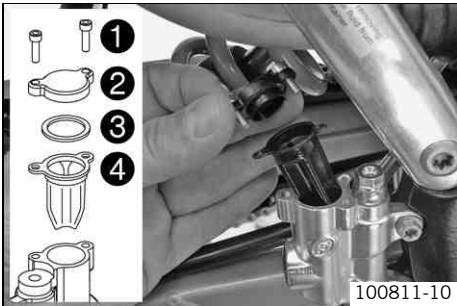

- Jack up the motorcycle. (🔧 p. 20)
- Remove screws ①.
- Take off cover ② with washer ③ and membrane ④.

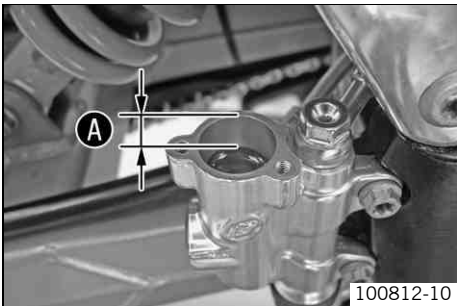

- Add brake fluid to level A.

Guideline

Dimension A (brake fluid level below top edge of container)	10 mm (0.39 in)
---	-----------------

Brake fluid DOT 4 / DOT 5.1 (🔧 p. 72)

- Position the membrane and the cover with the washer. Mount and tighten the screws.

**i Info**

Clean up overflowed or spilt brake fluid immediately with water.

## Checking the rear brake linings

**⚠ Warning**

**Danger of accidents** Reduced braking efficiency caused by worn brake linings.

- Change worn brake linings immediately. (Your authorized KTM workshop will be glad to help.)

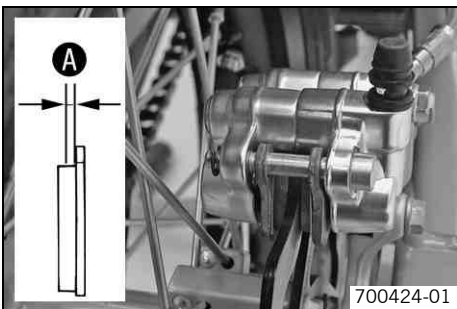

- Check the brake linings for minimum thickness A.

Minimum thickness A	≥ 1 mm (≥ 0.04 in)
---------------------	--------------------

- » If the minimum thickness is less than specified:
  - Change the rear brake linings. 🛠 (🔧 p. 46)
- Check the brake linings for damage and cracking.
  - » If damage or wear is encountered:
    - Change the rear brake linings. 🛠 (🔧 p. 46)

## Removing rear brake linings 🛠

**⚠ Warning**

**Danger of accident** Brake system failure.

- Maintenance work and repairs must be carried out professionally. (Your authorized KTM workshop will be glad to help.)

- Remove the rear wheel. 🛠 (🔧 p. 47)

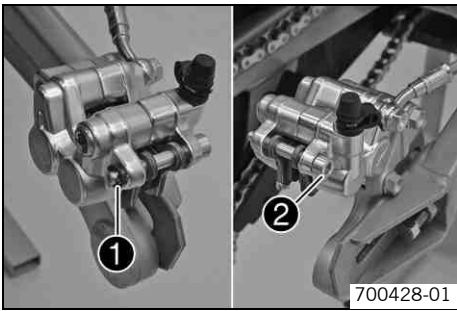

- Remove lock washer ❶.
- Remove screw ❷.

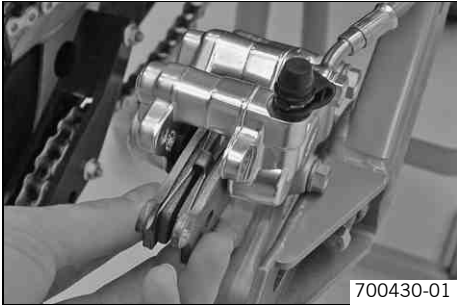

- Remove the brake linings.
- Clean brake caliper and brake caliper support.

## Installing the rear brake linings 🛠️



### Warning

**Danger of accidents** Reduced braking efficiency due to oil or grease on the brake discs.

- Always keep the brake discs free of oil and grease, and clean them with brake cleaner when necessary.



### Warning

**Danger of accidents** Reduced braking efficiency due to use of non-approved brake linings.

- Brake linings available from accessory suppliers are often not tested and approved for use on KTM vehicles. The construction and friction factor of the brake linings and therefore the brake power can differ considerably from the original KTM brake linings. If brake linings are used that differ from the originals, there is no guarantee that they comply with the original license. The vehicle no longer corresponds to the condition at delivery, and the warranty is no longer valid.

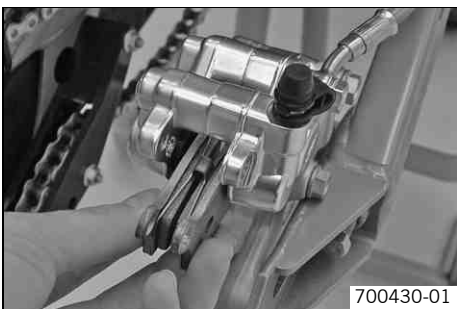

- Check the brake discs. (👉 p. 37)
- Insert the brake linings.



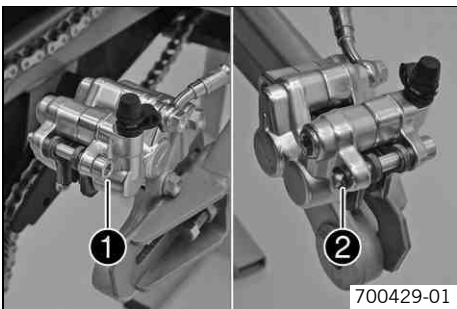

### Info

Ensure that the brake linings are correctly positioned in the holding spring.



- Mount screw ❶.
- Mount lock washer ❷.
- Install the rear wheel. 🛠️ (👉 p. 48)
- Operate the foot brake lever repeatedly until the brake linings lie on the brake disc and there is a pressure point.



## Changing the rear brake linings

- Warning**  
 **Skin irritation** Brake fluid can cause skin irritation on contact.
  - Avoid contact with skin and eyes, and keep out of the reach of children.
  - Wear suitable protective clothing and goggles.
  - If brake fluid gets into your eyes, rinse thoroughly with water and contact a doctor immediately.
- Warning**  
 **Danger of accidents** Reduced braking efficiency due to old brake fluid.
  - Change the brake fluid of the front and rear brakes according to the service schedule. (Your authorized KTM workshop will be glad to help.)
- Warning**  
 **Environmental hazard** Hazardous substances cause environmental damage.
  - Oil, grease, filters, fuel, cleaners, brake fluid, etc., should be disposed of as stipulated in applicable regulations.

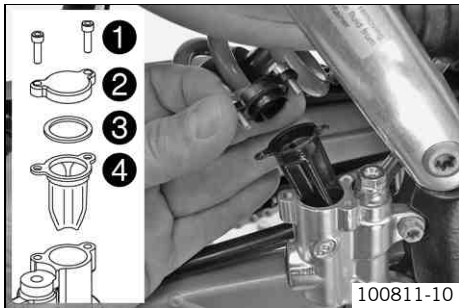
**i Info**  
 Never use DOT 5 brake fluid! This is based on silicone oil and is colored purple. Oil seals and brake lines are not designed for DOT 5 brake fluid.  
 Avoid contact between brake fluid and painted parts. Brake fluid attacks paint!  
 Use only clean brake fluid from a sealed container!



100811-10

- Remove the rear brake linings.  (☞ p. 44)
- Remove screws **1**.
- Take off cover **2** with washer **3** and membrane **4**.
- Press the brake piston back to its basic position and make sure that no brake fluid overflows from the brake fluid reservoir.
- Install the rear brake linings.  (☞ p. 45)

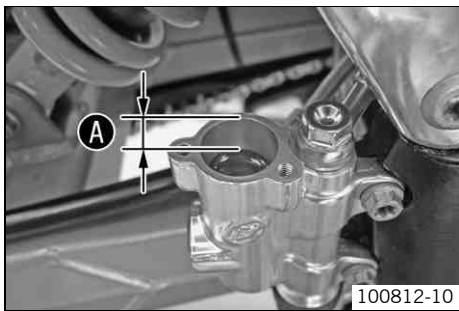

100812-10

- Add brake fluid to level **A**.

**Guideline**

Dimension <b>A</b> (brake fluid level below top edge of container)	10 mm (0.39 in)
--	-----------------

Brake fluid DOT 4 / DOT 5.1 (☞ p. 72)

- Position the membrane and the cover with the washer. Mount and tighten the screws.

**i Info**  
 Clean up overflowed or spilt brake fluid immediately with water.

## Removing the front wheel

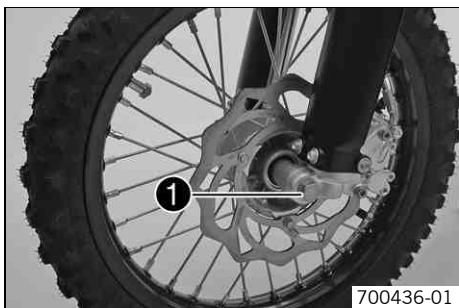

700436-01

- Jack up the motorcycle. (☞ p. 20)
- Remove screw **1**.



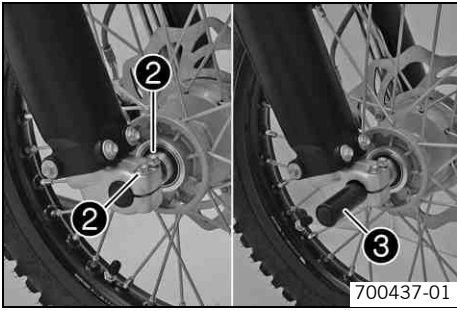

- Loosen screw ②.
- Hold the front wheel and pull out wheel spindle ③. Take the front wheel out of the fork.



**Info**

Do not pull the hand brake lever when the front wheel is removed. Always lay the wheel down in such a way that the brake disc is not damaged.

## Installing the front wheel ↩



**Warning**

**Danger of accidents** Reduced braking efficiency due to oil or grease on the brake discs.

- Always keep the brake discs free of oil and grease, and clean them with brake cleaner when necessary.

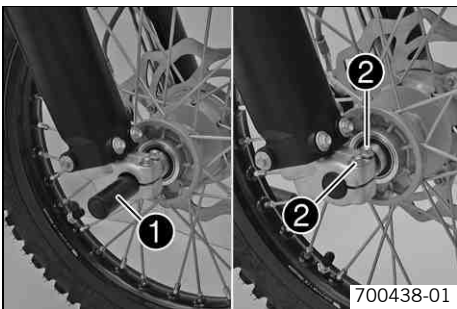

- Clean and grease wheel spindle ①.

Long-life grease (☞ p. 74)

- Lift the front wheel into the fork, position it, and insert wheel spindle ①.
- Tighten screws ②.

Guideline

Screw, fork stub	M6	10 Nm (7.4 lbf ft)
------------------	----	--------------------

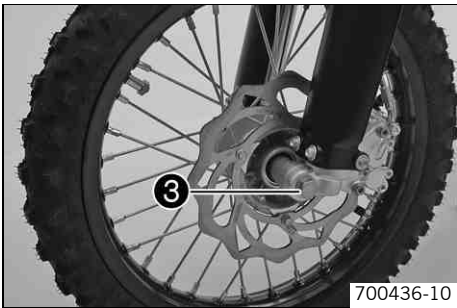

- Mount and tighten screw ③.

Guideline

Screw, front wheel spindle	M10	40 Nm (29.5 lbf ft)
----------------------------	-----	------------------------

- Remove the motorcycle from the work stand. (☞ p. 20)

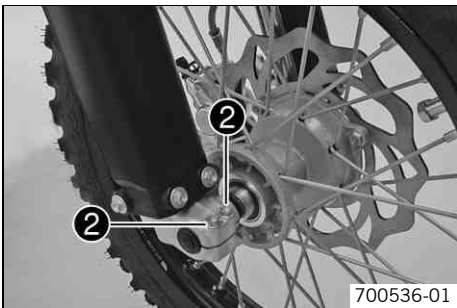

- Operate the hand brake lever several times until the brake pads are lying correctly on the brake disc.
- Loosen screw ②.
- Pull the front wheel brake and push down hard on the fork several times to align the fork legs.
- Tighten screws ②.

Guideline

Screw, fork stub	M6	10 Nm (7.4 lbf ft)
------------------	----	--------------------

## Removing the rear wheel ↩

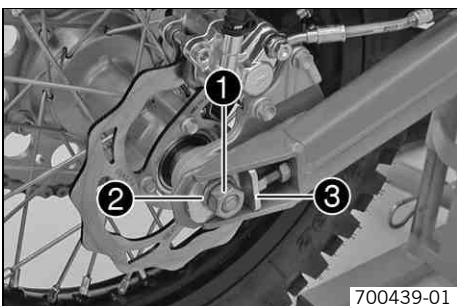

- Jack up the motorcycle. (☞ p. 20)
- Remove the chain guard. ↩ (☞ p. 33)
- Remove nut ①.
- Remove washer ② and chain adjuster ③.



100819-10

- Withdraw the wheel spindle ④ only enough to allow the rear wheel to be pushed forward.
- Push the rear wheel forward as far as possible. Remove the chain from the rear sprocket.
- Holding the rear wheel, withdraw the wheel spindle. Take the rear wheel out of the swingarm.



**Info**

Do not operate the foot brake when the rear wheel is removed. Always lay the wheel down in such a way that the brake disc is not damaged.

## Installing the rear wheel ↩



**Warning**

**Danger of accidents** Reduced braking efficiency due to oil or grease on the brake discs.

- Always keep the brake discs free of oil and grease, and clean them with brake cleaner when necessary.

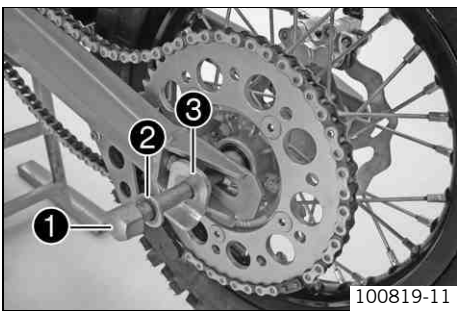

100819-11

- Clean and grease wheel spindle ①.
- Lift the rear wheel into the swingarm and position it.
- Insert the wheel spindle ① with washer ② and chain adjuster ③.
- Apply the chain.
- Position chain adjuster ③ and push the wheel spindle all the way in.

Long-life grease (☛ p. 74)

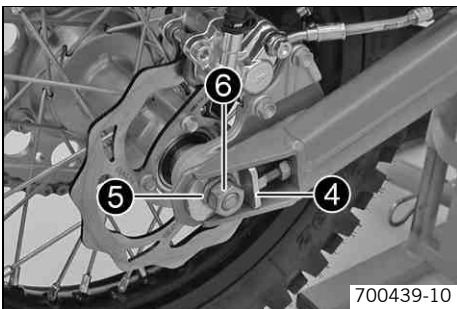

700439-10

- Position chain adjuster ④ and washer ⑤. Mount nut ⑥, but do not tighten it yet.
- Check chain tension when installing the rear wheel. (☛ p. 34)
- Make sure that the chain adjusters are fitted correctly on the adjusting screws.
- Tighten nut ⑥.

Guideline

Nut, rear wheel spindle	M12x1	40 Nm (29.5 lbf ft)
-------------------------	-------	------------------------

- Operate the foot brake lever repeatedly until the brake linings lie on the brake disc and there is a pressure point.
- Install the chain guard. (☛ p. 33)
- Remove the motorcycle from the work stand. (☛ p. 20)

## Checking the tire condition



**Info**

Only mount tires that have been approved and/or recommended by KTM. Other tires could have a negative effect on vehicle handling. The type, condition and air pressure of the tires all have an important impact on the handling characteristics of the motorcycle. The tires mounted on the front and rear wheels must have the same profile. Worn tires have a negative effect on vehicle handling, especially on wet surfaces.

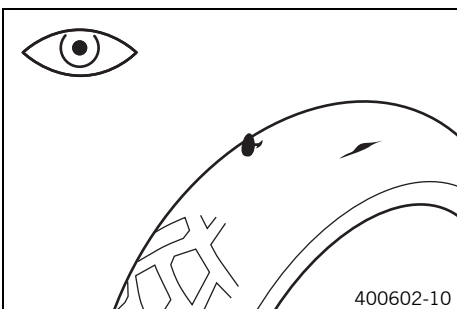

400602-10

- Check the front and rear tires for cuts, run-in objects and other damage.
  - » If the tires exhibit cuts, run-in objects or other damage:
    - Change the tires.
- Check the depth of the tread.



**Info**

Note local national regulations concerning the minimum tread depth.

Minimum tread depth	≥ 2 mm (≥ 0.08 in)
---------------------	--------------------

- » If the tread depth is less than the minimum permissible depth:
  - Change the tires.
- Check the tire age.



**Info**

The tire's date of manufacture is usually part of the tire markings and is indicated by the last four digits of the **DOT** marking. The first two digits refer to the week of manufacture and last two digits refer to the year of manufacture.

KTM recommends that the tires be changed regardless of the actual wear, at the latest after 5 years.

- » If a tire is more than 5 years old:
  - Change the tires.

## Checking tire air pressure



**Info**

Low tire air pressure leads to abnormal wear and overheating of the tire. Correct tire air pressure ensures optimal riding comfort and maximum tire service life.

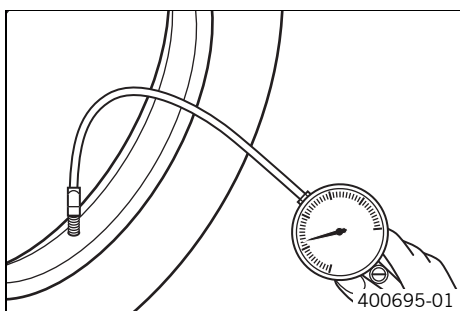

- Remove the dust cap.
- Check the tire air pressure when the tires are cold.

Tire air pressure off road	
Front	1.0 bar (15 psi)
Rear	1.0 bar (15 psi)

- » If the tire pressure does not meet specifications:
  - Correct the tire pressure.
- Mount the dust cap.

## Checking spoke tension



**Warning**

**Danger of accidents** Instable handling due to incorrect spoke tension.

- Ensure that the spoke tension is correct. (Your authorized KTM workshop will be glad to help.)



**Info**

A loose spoke can cause wheel imbalance, which leads to more loose spokes in a short time.

If the spokes are too tight, they can break due to local overload.

Check the spoke tension regularly, especially on a new motorcycle.

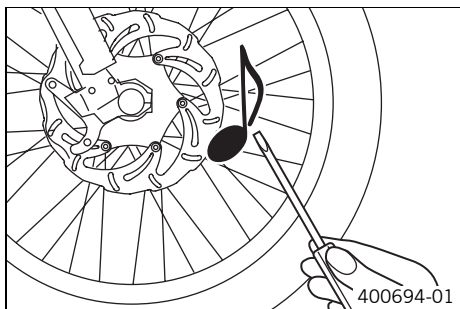

- Briefly strike each spoke with the blade of a screwdriver.



**Info**

The frequency of the tone depends on the spoke length and diameter.

If you hear different tone frequencies from spokes of the same length and thickness, this is an indication that the spoke tension differs.

You should hear a high note.

- » If the spoke tension differs:
  - Correct the spoke tension. 🛠️
- Check the spoke torque.

**Guideline**

Spoke nipple	M3.5	3 Nm (2.2 lbf ft)
--------------	------	-------------------

Torque wrench with various accessories in set (58429094000)

## Removing the seat

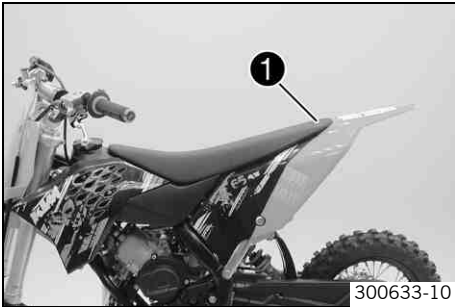

- Open quick release ❶ and raise the rear of the seat.
- Pull back the seat and remove it.

## Mounting the seat

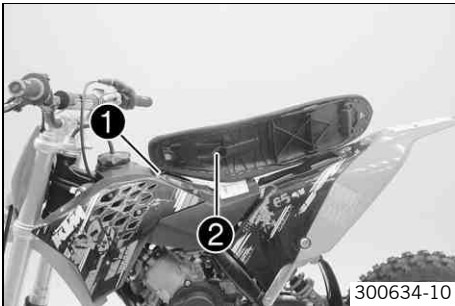

- Hook the seat onto screw ❶ and lower the seat at the rear while pushing it forward.
- ✓ Projection ❷ hooks into the fuel tank.

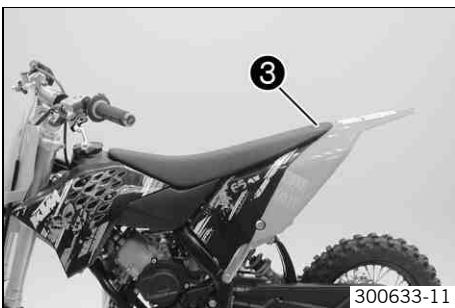

- Close quick release ❸.

## Cooling system

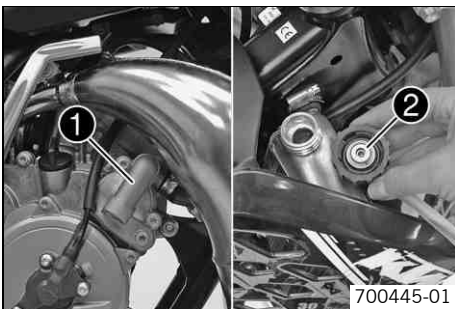

The water pump ❶ in the engine forces the coolant to flow. The pressure resulting from the warming of the cooling system is regulated by a valve in the radiator cap ❷. The specified coolant temperature is therefore permissible without danger of function problems.

120 °C (248 °F)
-----------------

Cooling is effected by the air stream. The lower the speed, the less the cooling effect. Dirty cooling fins also reduce the cooling effect.

## Checking the antifreeze and coolant level

- Warning**  
**Danger of scalding** During motorcycle operation, the coolant gets very hot and is under pressure.
- Do not open the radiator, radiator hoses or other cooling system components when the engine is hot. Allow the engine and cooling system to cool down. In case of burns, rinse immediately with lukewarm water.

- Warning**  
**Danger of poisoning** Coolants are poisonous and a health hazard.
- Avoid contact between coolants and skin, eyes and clothing. If fuel gets into your eyes, rinse immediately with water and contact a doctor. Wash affected skin areas immediately with soap and water. If coolant is swallowed, contact a doctor immediately. Change clothes that have come into contact with coolants. Keep coolants out of the reach of children.

**i Info**

Carry out this work with a cold engine.



700446-01

- Stand the motorcycle upright on a horizontal surface.
- Remove radiator cap ❶.
- Check the antifreeze of the coolant.

-25... -45 °C (-13... -49 °F)
-------------------------------

- » If the antifreeze of the coolant does not meet specifications:
  - Correct the antifreeze of the coolant.

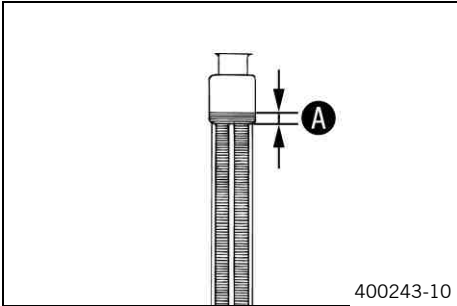

400243-10

- Check the coolant level in the radiator.

Coolant level <b>A</b> above the radiator fins	10 mm (0.39 in)
--	-----------------

- » If the coolant level does not meet specifications:
  - Correct the coolant level.

**Alternative 1**

Coolant (☛ p. 72)
-------------------

**Alternative 2**

Coolant (mixed ready to use) (☛ p. 72)
--

- Mount the radiator cap.

## Checking the coolant level

**Warning**

**Danger of scalding** During motorcycle operation, the coolant gets very hot and is under pressure.

- Do not open the radiator, radiator hoses or other cooling system components when the engine is hot. Allow the engine and cooling system to cool down. In case of burns, rinse immediately with lukewarm water.

**Warning**

**Danger of poisoning** Coolants are poisonous and a health hazard.

- Avoid contact between coolants and skin, eyes and clothing. If fuel gets into your eyes, rinse immediately with water and contact a doctor. Wash affected skin areas immediately with soap and water. If coolant is swallowed, contact a doctor immediately. Change clothes that have come into contact with coolants. Keep coolants out of the reach of children.

**i Info**

Carry out this work with a cold engine.

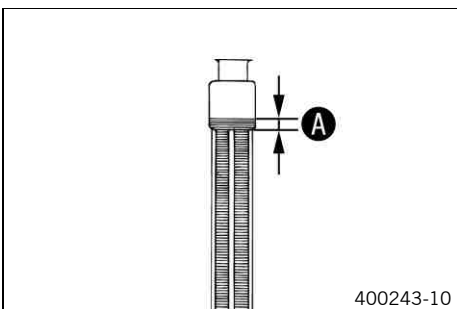

400243-10

- Stand the motorcycle upright on a horizontal surface.
- Remove the radiator cap.
- Check the coolant level in the radiator.

Coolant level <b>A</b> above the radiator fins	10 mm (0.39 in)
--	-----------------

- » If the coolant level does not meet specifications:
  - Correct the coolant level.

**Alternative 1**

Coolant (☛ p. 72)
-------------------

**Alternative 2**

Coolant (mixed ready to use) (☛ p. 72)
--

- Mount the radiator cap.

## Draining the coolant

- Warning**  
**Danger of scalding** During motorcycle operation, the coolant gets very hot and is under pressure.
- Do not open the radiator, radiator hoses or other cooling system components when the engine is hot. Allow the engine and cooling system to cool down. In case of burns, rinse immediately with lukewarm water.

- Warning**  
**Danger of poisoning** Coolants are poisonous and a health hazard.
- Avoid contact between coolants and skin, eyes and clothing. If fuel gets into your eyes, rinse immediately with water and contact a doctor. Wash affected skin areas immediately with soap and water. If coolant is swallowed, contact a doctor immediately. Change clothes that have come into contact with coolants. Keep coolants out of the reach of children.

**i Info**  
 Carry out this work with a cold engine.

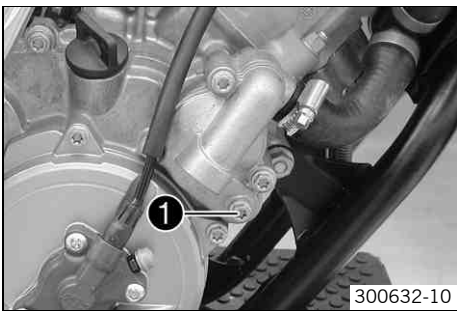

- Stand the vehicle upright.
- Place a suitable container beneath the water pump cover.
- Remove screw 1. Remove the radiator cap.
- Completely drain the coolant.
- Mount and tighten screw 1 with a new seal ring.

Guideline

Drain plug, water pump cover	M6	6 Nm (4.4 lbf ft)
------------------------------	----	-------------------

## Refilling coolant

- Warning**  
**Danger of poisoning** Coolants are poisonous and a health hazard.
- Avoid contact between coolants and skin, eyes and clothing. If fuel gets into your eyes, rinse immediately with water and contact a doctor. Wash affected skin areas immediately with soap and water. If coolant is swallowed, contact a doctor immediately. Change clothes that have come into contact with coolants. Keep coolants out of the reach of children.

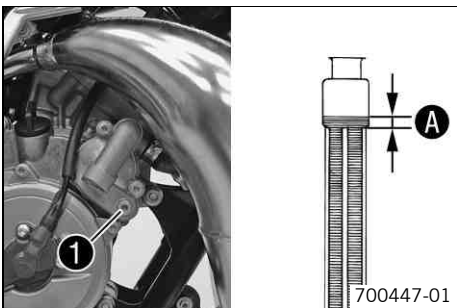

- Make sure that the screw 1 is tightened.
- Stand the vehicle upright.
- Add coolant to level A.

Guideline

Level A above the radiator fins	10 mm (0.39 in)
Coolant	0.55 l (0.58 qt.)
	Coolant (☛ p. 72) Coolant (mixed ready to use) (☛ p. 72)

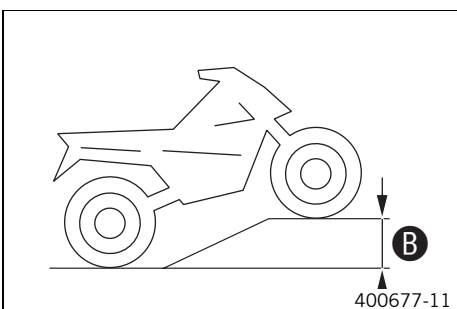

- Position the vehicle as shown and secure it against rolling away. A height difference of B must be reached.

Guideline

Height difference B	100 cm (39.4 in)
---------------------	------------------

**i Info**  
 To ensure that all of the air can escape from the cooling system, the front of the vehicle must be jacked up. A poorly bled cooling system is less effective at cooling and may result in overheating of the engine.

- Place the vehicle back on a level surface.
- Add coolant to level A.
- Mount the radiator cap.

- Make a short test ride.
- Check the coolant level. (☛ p. 51)

## Glass fiber yarn filling of main silencer

The main silencer is filled with glass fiber yarn.

Over a period, the fibers of the insulating material vanish into the air, and the silencer "burns out".

Not only is the noise level higher, the performance characteristic changes.

## Removing main silencer



### Warning

**Danger of burns** The exhaust system gets very hot when the vehicle is driven.

- Allow the exhaust system to cool down. Do not touch hot components.

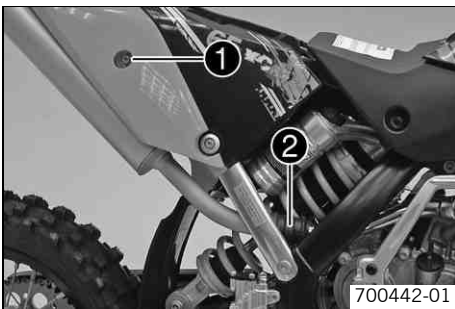

700442-01

- Remove screw ❶.
- Pull the main silencer off of the manifold at the rubber sleeve ❷.

## Installing the main silencer

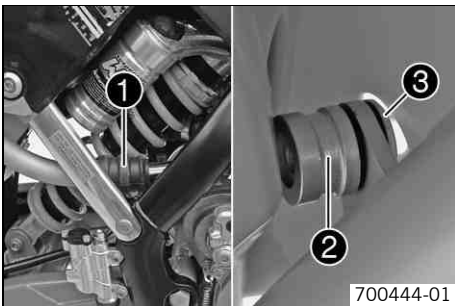

700444-01

- Mount the main silencer with the rubber sleeve ❶.
- Position the wide collar bushing ❷ and the narrow collar bushing ❸.



700442-10

- Mount and tighten screw ❹.

Guideline

Remaining screws, chassis	M6	10 Nm (7.4 lbf ft)
---------------------------	----	--------------------

## Removing the glass fiber yarn filling of the main silencer ☛



### Warning

**Danger of burns** The exhaust system gets very hot when the vehicle is driven.

- Allow the exhaust system to cool down. Do not touch hot components.

- Remove the main silencer. (☛ p. 53)

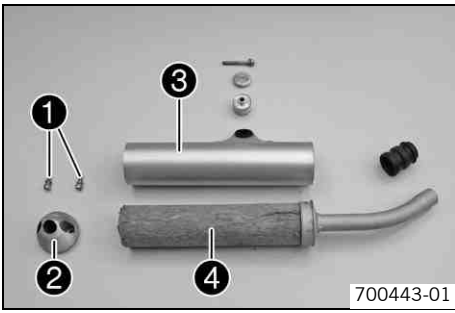

- Remove screws ① of locking cap ②. Remove locking cap and outer tube ③.
- Pull the glass fiber yarn filling ④ from the inner tube.
- Clean the parts that are to be reinstalled.

## Installing the glass fiber yarn filling of the main silencer ↩

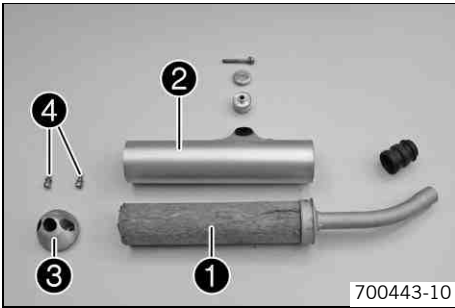

- Slide the glass fiber yarn filling ① over the inner tube.
- Slide the outer tube ② over the glass fiber yarn filling.
- Insert the locking cap ③ into the outer tube. Mount the screws ④ with toothed wheels and tighten.

Guideline

Remaining screws, chassis	M6	10 Nm (7.4 lbf ft)
---------------------------	----	--------------------

- Install the main silencer. (↩ p. 53)

## Removing the air filter ↩

### Note

**Engine failure** Unfiltered intake air has a negative effect on the service life of the engine.

- Never ride the vehicle without an air filter since dust and dirt can get into the engine and result in increased wear.



### Warning

**Environmental hazard** Hazardous substances cause environmental damage.

- Oil, grease, filters, fuel, cleaners, brake fluid, etc., should be disposed of as stipulated in applicable regulations.



- Remove the seat. (↩ p. 50)
- Unhook the air filter holder ① and swing it to the side. Remove the air filter with the air filter support.
- Remove the air filter from the air filter support.

## Installing the air filter ↩

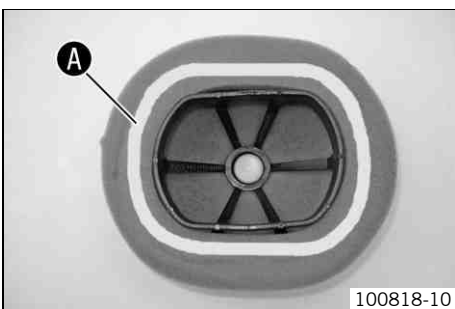

- Mount the clean air filter onto the air filter support.
- Grease the air filter in area A.

Long-life grease (↩ p. 74)
----------------------------





- Put in both parts together, position them and fix them with the air filter support ❶.



**Info**

If the air filter is not correctly mounted, dust and dirt can penetrate into the engine and can cause damage.

- Mount the seat. (☛ p. 50)

## Cleaning air filter ☛



**Warning**

**Environmental hazard** Hazardous substances cause environmental damage.

- Oil, grease, filters, fuel, cleaners, brake fluid, etc., should be disposed of as stipulated in applicable regulations.



**Info**

Do not clean the air filter with fuel or petroleum since these substances attack the foam.

- Remove the air filter. ☛ (☛ p. 54)
- Wash the air filter thoroughly in special cleaning liquid and allow it to dry properly.

Air filter cleaner (☛ p. 74)



**Info**

Only press the air filter to dry it, never wring it out.

- Oil the dry air filter with a high/quality filter oil.

Oil for foam air filter (☛ p. 74)

- Clean the air filter box.
- Check carburetor connection boot for damage and tightness.
- Install the air filter. ☛ (☛ p. 54)

## Carburetor - idle

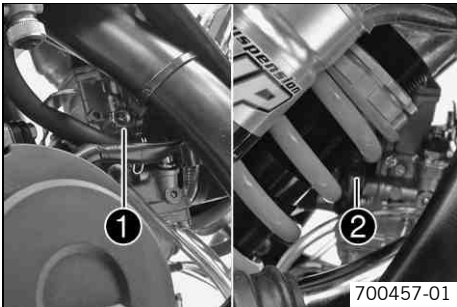

The idle setting of the carburetor has a big influence on the starting behavior, stable idling and the response to throttle opening. That means that an engine with a correctly set idle speed is easier to start than if the idle is set wrongly.



**Info**

The carburetor and its components are subject to increased wear caused by engine vibration. Wear can result in malfunctioning.

The idle speed is adjusted with adjusting screw ❶.  
The idle mixture is adjusted with idle adjusting screw ❷.

## Carburetor - adjusting the idle speed ☛

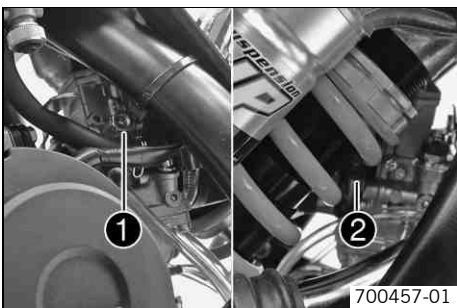

- Screw in idle air adjusting screw ❷ all the way and turn it to the specified basic position.

Guideline

Idle air adjusting screw	
Open	3.5 turns

- Run the engine until warm.

Guideline

Warm-up time	≥ 5 min
--------------	---------



**Danger**

**Danger of poisoning** Exhaust gases are poisonous and can result in unconsciousness and/or death.

- When running the engine, always make sure there is sufficient ventilation, and do not start or run the engine in a closed space without an effective exhaust extraction system.

- Adjust the idle speed with the adjusting screw ❶.

Guideline

Choke function deactivated – The choke lever is pushed up all the way. (☛ p. 11)

Idle speed	1,400... 1,500 rpm
------------	--------------------

- Turn idle air adjusting screw ❷ slowly in a clockwise direction until the idle speed begins to fall.
- Note the position and turn the idle air adjusting screw slowly counterclockwise until the idle speed falls again.
- Adjust to the point between these two positions with the highest idle speed.



**Info**

If the engine speed rises considerably, reduce the idle speed to a normal level and repeat the above steps.

If the procedure described here does not lead to satisfactory results, the cause may be a wrongly dimensioned idling jet.

If you can turn the idle air adjusting screw to the end without any change of engine speed, you need to install a smaller idling jet.

After changing the idling jet, start from the beginning with the adjusting steps.

Following extreme air temperature or altitude changes, adjust the idle speed again.

## Emptying the carburetor float chamber ☞



**Danger**

**Fire hazard** Fuel can easily catch fire.

- Never fill up the vehicle near open flames or burning cigarettes, and always switch off the engine first. Be careful that no fuel is spilt, especially on hot vehicle components. Clean up spilt fuel immediately.
- Fuel in the fuel tank expands when warm and can escape if the tank is overfilled. See specifications on filling up with fuel.



**Warning**

**Danger of poisoning** Fuel is poisonous and a health hazard.

- Avoid contact between fuel and skin, eyes and clothing. Do not inhale fuel vapors. If fuel gets into your eyes, rinse immediately with water and contact a doctor. Wash affected skin areas immediately with soap and water. If fuel is swallowed, contact a doctor immediately. Change clothing that has come into contact with fuel. Store fuel in a suitable canister according to regulations and keep it out of the reach of children.



**Warning**

**Environmental hazard** Improper handling of fuel is a danger to the environment.

- Do not allow fuel to get into the ground water, the ground, or the sewage system.



**Info**

Carry out this work with a cold engine.  
Water in the float chamber results in malfunctioning.

- Turn the knurled screw on the fuel tap all the way clockwise.  
✓ No more fuel flows from the tank to the carburetor.



- Place a cloth beneath the carburetor to soak up emerging fuel.
- Remove plug ❶.
- Completely drain the fuel.
- Mount and tighten the plug.

## Checking gear oil level



### Info

The gear oil level must be checked when the engine is cold.

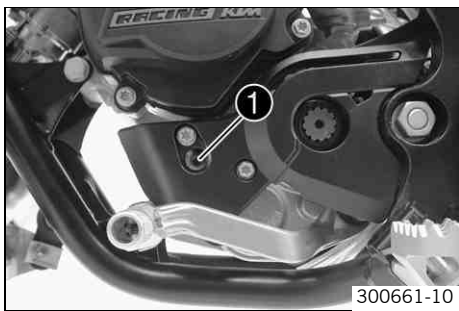

- Stand the motorcycle upright on a horizontal surface.
- Remove gear oil level check screw ❶. Stand the vehicle upright.
- Check the gear oil level.

A small amount of gear oil should flow out of the hole.

- » If no gear oil flows out:
  - Add gear oil. 🛠️ (📄 p. 58)

- Mount and tighten the gear oil level check screw.

Guideline

Screw, gear oil level check	M6	6 Nm (4.4 lbf ft)
-----------------------------	----	-------------------

## Changing the gear oil 🛠️

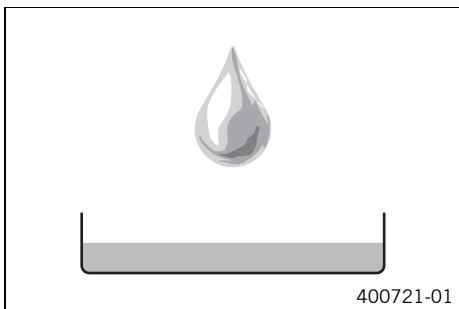

- Drain the gear oil. 🛠️ (📄 p. 57)

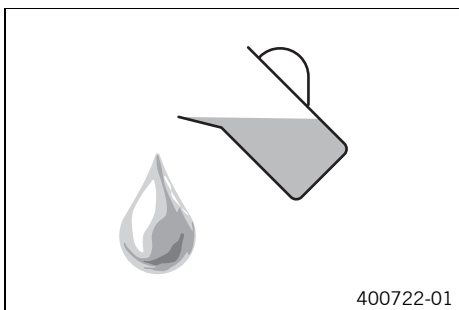

- Fill up with gear oil. 🛠️ (📄 p. 58)

## Draining the gear oil 🛠️



### Warning

**Danger of scalding** Engine oil and gear oil get very hot when the motorcycle is ridden.

- Wear appropriate protective clothing and safety gloves. In case of burns, rinse immediately with lukewarm water.



### Warning

**Environmental hazard** Hazardous substances cause environmental damage.

- Oil, grease, filters, fuel, cleaners, brake fluid, etc., should be disposed of as stipulated in applicable regulations.

**i** **Info**

Drain the gear oil only when the engine is warm.

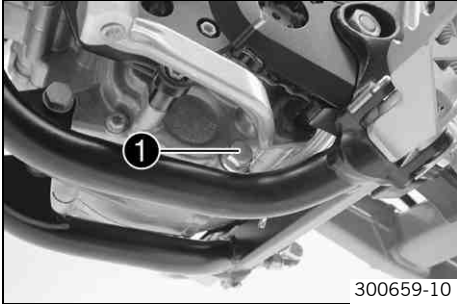

- Stand the motorcycle on its side stand on a horizontal surface.
- Place a suitable container under the engine.
- Remove the gear oil drain plug with magnet ❶.
- Completely drain the gear oil.
- Thoroughly clean gear oil drain plug with magnet.
- Clean the sealing area on the engine.
- Mount the gear oil drain plug with magnet and the seal ring and tighten it.

Guideline

Oil drain plug with magnet	M12x1.5	20 Nm (14.8 lbf ft)
----------------------------	---------	------------------------

## Filling up with gear oil

**i** **Info**

Too little gear oil or poor-quality oil results in premature wear of the transmission.

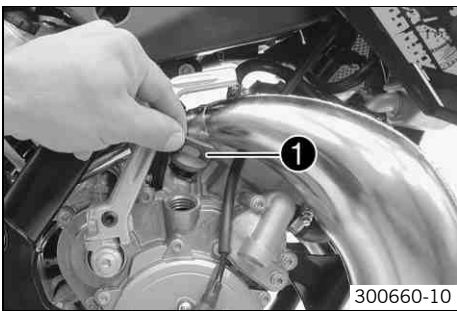

- Remove screw cap ❶ and fill up with gear oil.
- Mount and tighten screw cap.

Gear oil	0.50 l (0.53 qt.)	Engine oil (15W/50) (☛ p. 72)
----------	-------------------	-------------------------------



**Danger**

**Danger of poisoning** Exhaust gases are poisonous and can result in unconsciousness and/or death.

- When running the engine, always make sure there is sufficient ventilation, and do not start or run the engine in a closed space without an effective exhaust extraction system.

- Start the engine and check that it is oil-tight.
- Check the gear oil level. (☛ p. 57)

## Adding gear oil

**i** **Info**

Too little gear oil or poor-quality oil results in premature wear of the transmission.

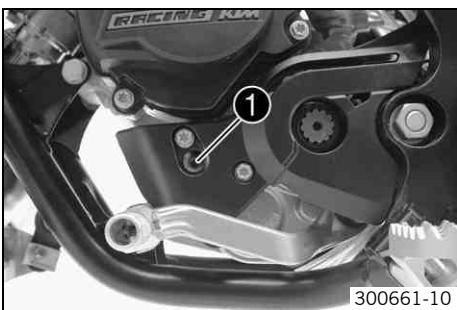

- Remove gear oil level check screw ❶.

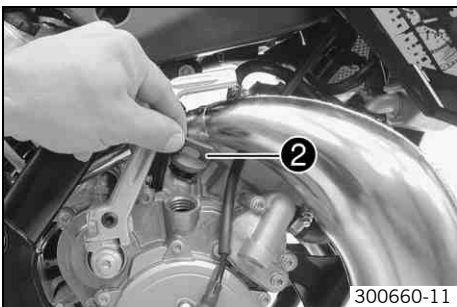

- Remove screw cap ❷. Stand the vehicle upright.
- Add gear oil until it flows out of the bore of the gear oil level screw.

Engine oil (15W/50) (☛ p. 72)
-------------------------------

- Mount and tighten the gear oil level check screw.

Guideline

Screw, gear oil level check	M6	6 Nm (4.4 lbf ft)
-----------------------------	----	-------------------

- Mount and tighten screw cap ❷.

**Danger**

**Danger of poisoning** Exhaust gases are poisonous and can result in unconsciousness and/or death.

- When running the engine, always make sure there is sufficient ventilation, and do not start or run the engine in a closed space without an effective exhaust extraction system.
- 
- Start the engine and check that it is oil-tight.

Faults	Possible cause	Action
Engine turns but does not start	Operating error	<ul style="list-style-type: none"> <li>Go through the steps of starting the engine. (☛ p. 15)</li> </ul>
	Motorcycle was out of use for a long time and there is old fuel in the float chamber	<ul style="list-style-type: none"> <li>Empty the carburetor float chamber. ☛ (☛ p. 56)</li> </ul>
	Fuel feed interrupted	<ul style="list-style-type: none"> <li>Check the fuel tank breather.</li> <li>Clean the fuel tap.</li> <li>Check/set the carburetor components. ☛</li> </ul>
	Engine flooded	<ul style="list-style-type: none"> <li>Clean and dry the spark plug, or change it if necessary.</li> </ul>
	Spark plug oily or wet	<ul style="list-style-type: none"> <li>Clean and dry the spark plug, or change it if necessary.</li> </ul>
	Electrode distance (plug gap) of spark plug too wide	<ul style="list-style-type: none"> <li>Adjust the plug gap.</li> </ul> Guideline Spark plug electrode gap 0.60 mm (0.0236 in)
	Fault in ignition system	<ul style="list-style-type: none"> <li>Check the ignition system. ☛</li> <li>Adjust the ignition. ☛</li> </ul>
	Short-circuit cable in cable harness frayed, short-circuit button defective	<ul style="list-style-type: none"> <li>Check the short circuit button. ☛</li> </ul>
	Socket connector or ignition coil is loose or oxidized	<ul style="list-style-type: none"> <li>Clean the socket connector and treat it with contact spray.</li> </ul>
Engine has no idle	Water in carburetor or jets blocked	<ul style="list-style-type: none"> <li>Check/set the carburetor components. ☛</li> </ul>
	Idling jet blocked	<ul style="list-style-type: none"> <li>Check/set the carburetor components. ☛</li> </ul>
	Adjusting screws on carburetor distorted	<ul style="list-style-type: none"> <li>Carburetor - adjust the idle speed. ☛ (☛ p. 55)</li> </ul>
	Spark plug defective	<ul style="list-style-type: none"> <li>Change spark plug.</li> </ul>
Engine does not speed up	Ignition system defective	<ul style="list-style-type: none"> <li>Check the ignition coil. ☛</li> <li>Check the spark plug connector. ☛</li> </ul>
	Carburetor running over because float needle dirty or worn	<ul style="list-style-type: none"> <li>Check/set the carburetor components. ☛</li> </ul>
	Loose carburetor jets	<ul style="list-style-type: none"> <li>Check/set the carburetor components. ☛</li> </ul>
Engine has too little power	Fault in ignition system	<ul style="list-style-type: none"> <li>Check the ignition system. ☛</li> <li>Adjust the ignition. ☛</li> </ul>
	Fuel feed interrupted	<ul style="list-style-type: none"> <li>Check the fuel tank breather.</li> <li>Clean the fuel tap.</li> <li>Check/set the carburetor components. ☛</li> </ul>
	Air filter very dirty	<ul style="list-style-type: none"> <li>Clean the air filter. ☛ (☛ p. 55)</li> </ul>
	Exhaust system leaky, deformed or too little glass fiber yarn filling in main silencer	<ul style="list-style-type: none"> <li>Check exhaust system for damage.</li> <li>Change the glass fiber yarn filling of the main silencer. ☛</li> </ul>
	Fault in ignition system	<ul style="list-style-type: none"> <li>Check the ignition system. ☛</li> <li>Adjust the ignition. ☛</li> </ul>
	Diaphragm or reed valve housing damaged	<ul style="list-style-type: none"> <li>Check the diaphragm and reed valve housing.</li> </ul>
Engine stalls or is popping into the carburetor	Noticeable wear	<ul style="list-style-type: none"> <li>Overhaul the engine.</li> </ul>
	Lack of fuel	<ul style="list-style-type: none"> <li>Turn the knurled screw on the fuel tap all the way counterclockwise.</li> <li>Fill up with fuel. (☛ p. 17)</li> </ul>
	Engine takes in bad air	<ul style="list-style-type: none"> <li>Check the intake flange and carburetor for tightness.</li> </ul>
Engine overheats	Socket connector or ignition coil is loose or oxidized	<ul style="list-style-type: none"> <li>Clean the socket connector and treat it with contact spray.</li> </ul>
	Too little coolant in cooling system	<ul style="list-style-type: none"> <li>Check the cooling system for leakage.</li> <li>Check the coolant level. (☛ p. 51)</li> </ul>

Faults	Possible cause	Action
Engine overheats	Too little air stream	- Switch off engine when standing.
	Radiator fins very dirty	- Clean radiator fins.
	Foam formation in cooling system	- Drain the coolant. 🛠️ (📖 p. 52) - Refill the coolant. 🛠️ (📖 p. 52)
	Damaged cylinder head or cylinder head gasket	- Check the cylinder head or cylinder head gasket.
	Bent radiator hose	- Change the radiator hose. 🛠️
	Incorrect ignition point due to loose stator	- Adjust the ignition. 🛠️
White smoke emission (steam in exhaust gas)	Damaged cylinder head or cylinder head gasket	- Check the cylinder head or cylinder head gasket.
Gear oil exits at the vent hose	Too much gear oil added	- Check the gear oil level. (📖 p. 57)
Water in the gear oil	Damaged shaft seal ring or water pump	- Check the shaft seal ring and water pump.

## Cleaning motorcycle

### Note

**Material damage** Damage and destruction of components by high-pressure cleaning equipment.

- Never clean the vehicle with high-pressure cleaning equipment or a strong water-jet. The excessive pressure can penetrate electrical components, socket connects, throttle cables, and bearings, etc., and can damage or destroy these parts.

### Warning



**Environmental hazard** Hazardous substances cause environmental damage.

- Oil, grease, filters, fuel, cleaners, brake fluid, etc., should be disposed of as stipulated in applicable regulations.

### Info

If you clean the motorcycle regularly, its value and appearance are maintained over a long period. Avoid direct sunshine on the motorcycle during cleaning.

- Before you clean the motorcycle, seal the exhaust system to prevent penetration by water.
- First remove coarse dirt particles with a gentle water spray.
- Spray very dirty areas with a normal motorcycle cleaner and then clean with a brush.

Motorcycle cleaner (☛ p. 74)

### Info

Use warm water containing normal motorcycle cleaner and a soft sponge.

- After rinsing the motorcycle with a gentle water spray, allow it to dry thoroughly.
- Empty the carburetor float chamber. 🛠 (☛ p. 56)

### Warning

**Danger of accidents** Reduced braking efficiency due to wet or dirty brakes.

- Clean or dry dirty or wet brakes by riding and braking gently.

- After cleaning, let your child ride the vehicle a short distance until the engine warms up and the brakes are dried.

### Info

The heat produced causes water at inaccessible positions in the engine and the brakes to evaporate.

- Push back the protection covers on the handlebar instruments to allow water to evaporate.
- After the motorcycle has cooled off, oil or grease all moving parts and bearings.
- Clean the chain. (☛ p. 32)
- Treat bare metal parts (except for brake discs and exhaust system) with anti-corrosion materials.

Cleaning and polishing materials for metal, rubber and plastic (☛ p. 74)

- Treat all plastic parts and powder-coated parts with a mild cleaning and care product.

Cleaning and polishing materials for metal, rubber and plastic (☛ p. 74)

- To prevent electrical problems, treat electric contacts and switches with contact spray.

Contact spray (☛ p. 74)



## Storage



### Warning

**Danger of poisoning** Fuel is poisonous and a health hazard.

- Avoid contact between fuel and skin, eyes and clothing. Do not inhale fuel vapors. If fuel gets into your eyes, rinse immediately with water and contact a doctor. Wash affected skin areas immediately with soap and water. If fuel is swallowed, contact a doctor immediately. Change clothing that has come into contact with fuel. Store fuel in a suitable canister according to regulations and keep it out of the reach of children.



### Info

If you want to garage the motorcycle for a longer period, take the following actions.

Before storing the motorcycle, check all parts for function and wear. If service, repairs or replacements are necessary, you should do this during the storage period (less workshop overload). In this way, you can avoid long workshop waiting times at the start of the new season.

- Clean the motorcycle. (🔧 p. 62)
- Change the gear oil. 🛢️ (🔧 p. 57)
- Check the antifreeze and coolant level. (🔧 p. 50)
- Drain the fuel from the tank into a suitable container.
- Empty the carburetor float chamber. 🛢️ (🔧 p. 56)
- Check the tire air pressure. (🔧 p. 49)
- The storage place should be dry and not subject to large temperature fluctuations.



### Info

KTM recommends jacking up the motorcycle.

- Jack up the motorcycle. (🔧 p. 20)
- Cover the motorcycle with a porous sheet or blanket. Do not use non-porous materials since they prevent humidity from escaping, thus causing corrosion.



### Info

Avoid running the engine for a short time only. Since the engine cannot warm up properly, the water vapor produced during combustion condenses and causes valves and exhaust system to rust.

## Putting into operation after storage

- Remove the motorcycle from the work stand. (🔧 p. 20)
- Fill up with fuel. (🔧 p. 17)
- Checks before putting into operation. (🔧 p. 15)
- Take a test ride.

Design	1-cylinder 2-stroke engine, water-cooled, with reed intake and exhaust control	
Displacement	64.85 cm <sup>3</sup> (3.9574 cu in)	
Stroke	40.8 mm (1.606 in)	
Bore	45 mm (1.77 in)	
Control	Exhaust control PCEV	
Crankshaft bearing	2 grooved ball bearings	
Conrod bearing	Needle bearing	
Piston pin bearing	Needle bearing	
Pistons	Aluminum cast	
Piston rings	1 rectangular ring	
Engine lubrication	Mixture oil lubrication	
Primary transmission	23:75 straight cut spur gear	
Clutch	Multidisc clutch in oil bath/hydraulically activated	
Gearbox	6-gear, claw shifted	
Transmission ratio		
1st gear	13:37	
2nd gear	16:34	
3rd gear	18:31	
4th gear	21:30	
5th gear	23:28	
6th gear	24:26	
Ignition	AET digital	
Spark plug	NGK LR 8 B	
Spark plug electrode gap	0.60 mm (0.0236 in)	
Cooling	Water-cooled	
Starting aid	Kickstarter	

## Capacity - gear oil

Gear oil	0.50 l (0.53 qt.)	Engine oil (15W/50) (☛ p. 72)
----------	-------------------	-------------------------------

## Capacity - coolant

Coolant	0.55 l (0.58 qt.)	Coolant (☛ p. 72)
		Coolant (mixed ready to use) (☛ p. 72)

Bearing retainer, main shafts	M5		Loctite® 648™
Nut, exhaust control diaphragm	M5	3 Nm (2.2 lbf ft)	–
Screw, clutch line holder	M5	5 Nm (3.7 lbf ft)	Loctite® 243™
Screw, diaphragm cover of exhaust control	M5	4 Nm (3 lbf ft)	–
Screw, ignition system/stator	M5	5 Nm (3.7 lbf ft)	Loctite® 222
Screw, reed valve housing of exhaust control	M5	4 Nm (3 lbf ft)	–
Screw, retaining bracket for return spring of shift shaft	M5	6 Nm (4.4 lbf ft)	Loctite® 243™
Screw, shift drum locating	M5	6 Nm (4.4 lbf ft)	Loctite® 243™
Screw, water pump wheel	M5	5 Nm (3.7 lbf ft)	Loctite® 243™
Bearing retainer, shift drum	M6	8 Nm (5.9 lbf ft)	Loctite® 243™
Drain plug, water pump cover	M6	6 Nm (4.4 lbf ft)	–
Screw, clutch intermediate cover	M6	10 Nm (7.4 lbf ft)	–
Screw, clutch slave cylinder	M6	10 Nm (7.4 lbf ft)	Loctite® 243™
Screw, clutch springs	M6	10 Nm (7.4 lbf ft)	–
Screw, engine housing	M6	10 Nm (7.4 lbf ft)	–
Screw, engine sprocket cover	M6	10 Nm (7.4 lbf ft)	–
Screw, exhaust flange	M6	10 Nm (7.4 lbf ft)	Loctite® 243™
Screw, gear oil level check	M6	6 Nm (4.4 lbf ft)	–
Screw, generator cover	M6	8 Nm (5.9 lbf ft)	–
Screw, intake flange/reed valve housing	M6	10 Nm (7.4 lbf ft)	–
Screw, kickstarter stop piece	M6	10 Nm (7.4 lbf ft)	Loctite® 243™
Screw, outer clutch cover	M6	10 Nm (7.4 lbf ft)	–
Screw, reed valve housing of exhaust control	M6	10 Nm (7.4 lbf ft)	–
Screw, shift drum locating	M6	10 Nm (7.4 lbf ft)	Loctite® 243™
Screw, shift lever	M6	14 Nm (10.3 lbf ft)	Loctite® 243™
Screw, water pump cover	M6	8 Nm (5.9 lbf ft)	–
Vacuum connection/vent connection	M6	5 Nm (3.7 lbf ft)	Loctite® 243™
Screw, cylinder head	M7	18 Nm (13.3 lbf ft)	–
Nuts, cylinder base	M8	20 Nm (14.8 lbf ft)	–
Screw, kickstarter	M8	25 Nm (18.4 lbf ft)	Loctite® 243™
Stud, cylinder base (left section of the engine case)	M8	Tightening sequence: screw in until it projects by 27 mm (1.063 in)	Loctite® 243™
Stud, cylinder base (right section of the engine case)	M8	Tightening sequence: screw in until it projects by 29 mm (1.142 in)	Loctite® 243™
Screw, inner clutch hub	M10	60 Nm (44.3 lbf ft)	Loctite® 243™
Spark plug	M10x1	10... 12 Nm (7.4... 8.9 lbf ft)	–
Nut, rotor	M10x1.25	50 Nm (36.9 lbf ft)	–
Oil drain plug with magnet	M12x1.5	20 Nm (14.8 lbf ft)	–
Nut, primary gear	M14x1.25	40 Nm (29.5 lbf ft)	Loctite® 243™

## Basic setting

Carburetor type	MIKUNI TM 24
Needle position	2nd position from top
Idle air adjusting screw	
Open	3.5 turns
Main jet	210
Jet needle	5IPL43
Idling jet	20
Needle jet	Q-0 (454)
Throttle slide	2.5

## Carburetor configuration

MIKUNI TM 24							
M/FT ASL	TEMP	-20°C ... -7°C	-6°C ... 5°C	6°C ... 15°C	16°C ... 24°C	25°C ... 36°C	37°C ... 49°C
↓	→	-2°F ... 20°F	19°F ... 41°F	42°F ... 60°F	61°F ... 78°F	79°F ... 98°F	99°F ... 120°F
3.000 m 10,000 ft ↑	ASO IJ NDL POS MJ	3,5 20 5IPL43 2 210	3,5 20 5IPL43 1 210	3,5 15 5IPL43 1 205	3,5 15 5IPL43 1 200	3,5 10 5IPL43 1 195	
2.300 m 7,500 ft ↑	ASO IJ NDL POS MJ	3,5 20 5IPL43 2 210	3,5 20 5IPL43 2 210	3,5 20 5IPL43 1 210	3,5 15 5IPL43 1 205	3,5 15 5IPL43 1 200	3,5 10 5IPL43 1 195
1.500 m 5,000 ft ↑	ASO IJ NDL POS MJ	3,5 20 5IPL43 3 215	3,5 20 5IPL43 2 210	3,5 20 5IPL43 2 210	3,5 20 5IPL43 1 210	3,5 15 5IPL43 1 205	3,5 15 5IPL43 1 200
750 m 2,500 ft ↑	ASO IJ NDL POS MJ	2,5 25 5IPL43 3 220	3,5 20 5IPL43 3 215	3,5 20 5IPL43 2 210	<b>3,5</b> <b>20</b> <b>5IPL43</b> <b>2</b> <b>210</b>	3,5 20 5IPL43 1 210	3,5 15 5IPL43 1 205
300 m 1,000 ft ↑	ASO IJ NDL POS MJ	2 25 5IPL43 4 225	2,5 25 5IPL43 3 220	3,5 20 5IPL43 3 215	3,5 20 5IPL43 2 210	3,5 20 5IPL43 2 210	3,5 20 5IPL43 1 210
0 m 0 ft							

100810-01

M/FT ASL	Above sea level
TEMP	Temperature
ASO	Idle air adjusting screw open (rotations)
IJ	Idling jet
NDL	Jet needle

POS	Needle position from above
MJ	Main jet

The carburetor configuration depends on the ambient and operating conditions.

**Info**

Does not apply to sand surfaces!

Additional information can be obtained from your authorized KTM workshop.

---

Frame	Central tube frame of chrome molybdenum steel tubing, powder-coated
Fork	<b>Marzocchi</b> Upside down
Shock absorber	<b>WP Suspension</b> 3614 BAVP
Suspension travel	
Front	220 mm (8.66 in)
Rear	270 mm (10.63 in)
Fork offset	18 mm (0.71 in)
Brake system	
Front	Disc brake, brake caliper, fixed
Rear	Disc brake, brake caliper, fixed
Brake disc diameters	
Front	198 mm (7.8 in)
Rear	160 mm (6.3 in)
Brake discs - wear limits	
Front	2.5 mm (0.098 in)
Rear	2.5 mm (0.098 in)
Tire air pressure off road	
Front	1.0 bar (15 psi)
Rear	1.0 bar (15 psi)
Secondary drive ratio	14:50
Chain	1/2 x 1/4" O-ring
Rear sprockets available	46, 48, 50
Steering head angle	64.5°
Wheelbase	1,137 mm (44.76 in)
Seat height unloaded	750 mm (29.53 in)
Ground clearance unloaded	280 mm (11.02 in)
Weight without fuel, approx.	55.4 kg (122.1 lb.)
Maximum rider weight	< 50 kg (< 110 lb.)

## Tires

Front tire	Rear tire
<b>60/100 - 14 29M TT</b> Pirelli SCORPION MX Mid Soft 32 NHS	<b>80/100 - 12 50M TT</b> Pirelli SCORPION MX Mid Soft 32 NHS
Additional information is available in the Service section under: <a href="http://www.ktm.com">http://www.ktm.com</a>	

## Capacity - fuel

Fuel tank capacity, approx.	3.5 l (3.7 qt.)	Super unleaded gasoline, mixed with 2-stroke engine oil (1:60) (☛ p. 73)
-----------------------------	-----------------	---

Fork part number	46201000033	
Fork	<b>Marzocchi</b> Upside down	
Compression damping		
Standard	10 clicks	
Rebound damping		
Standard	10 clicks	
Spring rate		
Weight of rider: 35... 45 kg (77... 99 lb.)	3.4 N/mm (19.4 lb/in)	
Air chamber length	100±2.5 mm (3.94±0.098 in)	
Fork length	735 mm (28.94 in)	
Fork oil	220 ml (7.44 fl. oz.)	Fork oil (SAE 7.5) (☛ p. 72)

Shock absorber part number	03.18.7E.03
Shock absorber	<b>WP Suspension 3614 BAVP</b>
Compression damping	
Comfort	10 clicks
Standard	9 clicks
Sport	3 clicks
Rebound damping	
Comfort	10 clicks
Standard	9 clicks
Sport	6 clicks
Spring preload	
Comfort	7 mm (0.28 in)
Standard	7 mm (0.28 in)
Sport	7 mm (0.28 in)
Spring rate	
Weight of rider: < 35 kg (< 77 lb.)	35 N/mm (200 lb/in)
Weight of rider: 35... 45 kg (77... 99 lb.)	40 N/mm (228 lb/in)
Weight of rider: > 45 kg (> 99 lb.)	45 N/mm (257 lb/in)
Spring length	220 mm (8.66 in)
Gas pressure	10 bar (145 psi)
Static sag	12 mm (0.47 in)
Riding sag	90 mm (3.54 in)
Fitted length	347 mm (13.66 in)
Shock absorber oil	Shock absorber oil (SAE 2.5) (50180342S1) (☛ p. 73)



Spoke nipple	M3.5	3 Nm (2.2 lbf ft)	–
Remaining nuts, chassis	M6	15 Nm (11.1 lbf ft)	–
Remaining screws, chassis	M6	10 Nm (7.4 lbf ft)	–
Screw, ball joint, push rod on foot-brake cylinder	M6	10 Nm (7.4 lbf ft)	–
Screw, footbrake cylinder	M6	10 Nm (7.4 lbf ft)	<b>Loctite® 243™</b>
Screw, fork stub	M6	10 Nm (7.4 lbf ft)	–
Screw, front brake disc	M6	14 Nm (10.3 lbf ft)	–
Screw, rear brake disc	M6	14 Nm (10.3 lbf ft)	<b>Loctite® 243™</b>
Screw, throttle grip	M6	4.5 Nm (3.32 lbf ft)	–
Nut, rim lock	M8	10 Nm (7.4 lbf ft)	–
Remaining nuts, chassis	M8	30 Nm (22.1 lbf ft)	–
Remaining screws, chassis	M8	25 Nm (18.4 lbf ft)	–
Screw, bottom triple clamp	M8	25 Nm (18.4 lbf ft)	–
Screw, brake caliper	M8	20 Nm (14.8 lbf ft)	<b>Loctite® 243™</b>
Screw, engine bracket	M8	30 Nm (22.1 lbf ft)	–
Screw, foot brake pedal	M8	25 Nm (18.4 lbf ft)	–
Screw, handlebar clamp	M8	20 Nm (14.8 lbf ft)	–
Screw, rear sprocket	M8	25 Nm (18.4 lbf ft)	<b>Loctite® 243™</b>
Screw, side stand fixing	M8	40 Nm (29.5 lbf ft)	<b>Loctite® 243™</b>
Screw, tail piece	M8	35 Nm (25.8 lbf ft)	<b>Loctite® 243™</b>
Screw, top triple clamp	M8	25 Nm (18.4 lbf ft)	–
Remaining nuts, chassis	M10	50 Nm (36.9 lbf ft)	–
Remaining screws, chassis	M10	45 Nm (33.2 lbf ft)	–
Screw, bottom shock absorber	M10	45 Nm (33.2 lbf ft)	–
Screw, front wheel spindle	M10	40 Nm (29.5 lbf ft)	–
Screw, handlebar support	M10	40 Nm (29.5 lbf ft)	<b>Loctite® 243™</b>
Screw, top shock absorber	M10	45 Nm (33.2 lbf ft)	–
Nut, rear wheel spindle	M12x1	40 Nm (29.5 lbf ft)	–
Nut, swingarm pivot	M12x1	40 Nm (29.5 lbf ft)	–
Nut, steering stem	M20x1.5	10 Nm (7.4 lbf ft)	–

## Brake fluid DOT 4 / DOT 5.1

**According to**

- DOT

**Guideline**

- Use only brake fluid that complies with the specified standards (see specifications on the container) and that possesses the corresponding properties. KTM recommends **Castrol** and **Motorex®** products.

**Supplier**

**Castrol**

- **RESPONSE BRAKE FLUID SUPER DOT 4**

**Motorex®**

- **Brake Fluid DOT 5.1**

## Coolant

**Guideline**

- Use only suitable coolant (also in countries with high temperatures). Use of low-quality antifreeze can lead to corrosion and foaming. KTM recommends **Motorex®** products.

**Mixture ratio**

Antifreeze protection: -25... -45 °C (-13... -49 °F)	50 % corrosion inhibitor/antifreeze 50 % distilled water
--	---

## Coolant (mixed ready to use)

Antifreeze	-40 °C (-40 °F)
------------	-----------------

**Supplier**

**Motorex®**

- **Anti Freeze**

## Engine oil (15W/50)

**According to**

- JASO T903 MA (☛ p. 76)
- SAE (☛ p. 76) (15W/50)

**Guideline**

- Use only engine oils that comply with the specified standards (see specifications on the container) and that possess the corresponding properties. KTM recommends **Motorex®** products.

**Supplier**

**Motorex®**

- **Top Speed 4T**

## Fork oil (SAE 7.5)

**According to**

- SAE (☛ p. 76) (SAE 7.5)

**Guideline**

- Use only oils that comply with the specified standards (see specifications on the container) and that possess the corresponding properties. KTM recommends **Motorex®** products.

**Supplier**

**Motorex®**

- **Racing Fork Oil**

## Hydraulic fluid (15)

**According to**

- ISO VG (15)

**Guideline**

- Use only hydraulic fluid that complies with the specified standards (see specifications on the container) and that possesses the corresponding properties. KTM recommends **Motorex®** products.

**Supplier**

**Motorex®**

- **Hydraulic Fluid 75**

## Shock absorber oil (SAE 2.5) (50180342S1)

### According to

- SAE (☛ p. 76) (SAE 2.5)

### Guideline

- Use only oils that comply with the specified standards (see specifications on the container) and that possess the corresponding properties.

## Super unleaded gasoline, mixed with 2-stroke engine oil (1:60)

### According to

- DIN EN 228
- JASO FC (☛ p. 76) (1:60)

### Mixture ratio

1:60	2-stroke engine oil Super unleaded (ROZ 95 / RON 95 / PON 91)
------	--

## Air filter cleaner

### Guideline

- KTM recommends **Motorex®** products.

### Supplier

#### Motorex®

- **Twin Air Dirt Bio Remover**

## Chain cleaner

### Guideline

- KTM recommends **Motorex®** products.

### Supplier

#### Motorex®

- **Chain Clean 611**

## Cleaning and polishing materials for metal, rubber and plastic

### Guideline

- KTM recommends **Motorex®** products.

### Supplier

#### Motorex®

- **Protect & Shine 645**

## Contact spray

### Guideline

- KTM recommends **Motorex®** products.

### Supplier

#### Motorex®

- **Accu Contact**

## Long-life grease

### Guideline

- KTM recommends **Motorex®** products.

### Supplier

#### Motorex®

- **Fett 2000**

## Motorcycle cleaner

### Guideline

- KTM recommends **Motorex®** products.

### Supplier

#### Motorex®

- **Moto Clean 900**

## Offroad chain spray

### Guideline

- KTM recommends **Motorex®** products.

### Supplier

#### Motorex®

- **Chain Lube 622**

## Oil for foam air filter

### Guideline

- KTM recommends **Motorex®** products.

### Supplier

#### Motorex®

- **Twin Air Liquid Bio Power**

## Universal oil spray

### Guideline

- KTM recommends **Motorex**<sup>®</sup> products.

### Supplier

#### **Motorex**<sup>®</sup>

- **Joker 440 Universal**

## **JASO T903 MA**

Different technical development directions required a new specification for 4-stroke motorcycles – the JASO T903 MA Standard. Earlier, engine oils from the automobile industry were used for 4-stroke motorcycles because there was no separate motorcycle specification. Whereas long service intervals are demanded for automobile engines, high performance at high engine speeds are in the foreground for motorcycle engines. With most motorcycles, the gearbox and the clutch are lubricated with the same oil as the engine. The JASO MA Standard meets these special requirements.

## **SAE**

The SAE viscosity classes were defined by the Society of Automotive Engineers and are used for classifying oils according to their viscosity. The viscosity describes only one property of oil and says nothing about quality.

## **JASO FC**

JASO FC is a classification for a 2-stroke engine oil that was specifically developed for the extreme demands of racing. Thanks to first rate synthetic esters and specially designed additives, superb combustion is achieved even under extreme operating conditions.

**A**

**Air filter**  
 cleaning ..... 55  
 installing ..... 54  
 removing ..... 54

**Antifreeze**  
 checking ..... 50

**B**

**Brake discs**  
 checking ..... 37

**Brake fluid**  
 front brake fluid, adding ..... 39  
 of rear brake, adding ..... 43

**Brake fluid level**  
 front brake, checking ..... 38  
 rear brake, checking ..... 43

**Brake linings**  
 front brake linings, changing ..... 41  
 front brake, checking ..... 40  
 front brake, installing ..... 40  
 front brake, removing ..... 40  
 rear brake, changing ..... 46  
 rear brake, checking ..... 44  
 rear brake, installing ..... 45  
 rear brake, removing ..... 44

**C**

**Carburetor**  
 float chamber, emptying ..... 56  
 idle ..... 55  
 idle speed, adjusting ..... 55

**Chain**  
 cleaning ..... 32

**Chain guard**  
 installing ..... 33  
 removing ..... 33

**Chain guide**  
 adjusting ..... 36

**Chain tension**  
 adjusting ..... 34  
 checking ..... 33

**Chassis number** ..... 9

**Choke** ..... 11

**Cleaning** ..... 62

**Clutch**  
 fluid level, checking ..... 36  
 fluid, changing ..... 36

**Clutch lever** ..... 10  
 adjusting basic position ..... 36

**Compression damping**  
 fork, adjusting ..... 23  
 shock absorber, adjusting ..... 20

**Coolant**  
 draining ..... 52  
 refilling ..... 52

**Coolant level**  
 checking ..... 50-51

**Cooling system** ..... 50

**E**

**Engine**  
 running in ..... 14

**Engine number** ..... 9

**Environment** ..... 6

**F**

**Filler cap**  
 closing ..... 11  
 opening ..... 11

**Filling up**  
 fuel ..... 17

**Foot brake pedal** ..... 12  
 basic position, adjusting ..... 42  
 free travel, adjusting ..... 42  
 free travel, checking ..... 42

**Fork legs**  
 bleeding ..... 25  
 dust boots, cleaning ..... 25  
 installing ..... 27  
 removing ..... 26

**Fork overhang**  
 adjusting ..... 24

**Fork protector**  
 installing ..... 28  
 removing ..... 27

**Front fender**  
 installing ..... 30  
 removing ..... 30

**Front wheel**  
 installing ..... 47  
 removing ..... 46

**Fuel tap** ..... 10

**Fuel, oils, etc.** ..... 5

**G**

**Gear oil**  
 adding ..... 58  
 changing ..... 57  
 draining ..... 57  
 refilling ..... 58

**Gear oil level**  
 checking ..... 57

**H**

**Hand brake lever** ..... 10  
 basic position, adjusting ..... 38  
 free travel, checking ..... 38

**Handlebar position** ..... 31  
 adjusting ..... 31

**K**

**Kickstarter** ..... 12

**L**

**Lower triple clamp**  
 installing ..... 29  
 removing ..... 28

**M**

**Main silencer**  
 glass fiber yarn filling, installing . . . . . 54  
 glass fiber yarn filling, removing . . . . . 53  
 installing . . . . . 53  
 removing . . . . . 53

**Maintenance** . . . . . 5

**Motorcycle**  
 cleaning . . . . . 62

**O**

**Owner's manual**  
 general information . . . . . 6

**P**

**Play in throttle cable**  
 adjusting . . . . . 32  
 checking . . . . . 32

**Plug-in stand** . . . . . 12

**Putting into operation**  
 advice on first use . . . . . 13  
 after storage . . . . . 63  
 checks before putting into operation . . . . . 15

**R**

**Rear sprocket / engine sprocket**  
 checking for wear . . . . . 34

**Rear wheel**  
 installing . . . . . 48  
 removing . . . . . 47

**Rebound damping**  
 fork, adjusting . . . . . 23  
 shock absorber, adjusting . . . . . 20

**Riding sag**  
 adjusting . . . . . 22

**S**

**Seat**  
 mounting . . . . . 50  
 removing . . . . . 50

**Service schedule** . . . . . 18-19

**Shift lever** . . . . . 11

**Shock absorber**  
 installing . . . . . 23  
 removing . . . . . 23  
 riding sag, checking . . . . . 21  
 static sag, checking . . . . . 21

**Shock absorber part number** . . . . . 9

**Short circuit button** . . . . . 10

**Spare parts, accessories** . . . . . 5

**Spoke tension**  
 checking . . . . . 49

**Spring preload**  
 shock absorber, adjusting . . . . . 22

**Start number plate**  
 installing . . . . . 30  
 removing . . . . . 30

**Starting** . . . . . 15

**Steering head bearing**  
 greasing . . . . . 29

**Steering head bearing play**  
 adjusting . . . . . 26  
 checking . . . . . 25

**Storage** . . . . . 63

**T**

**Technical data**  
 carburetor . . . . . 66-67  
 chassis . . . . . 68  
 chassis tightening torques . . . . . 71  
 engine . . . . . 64  
 engine tightening torques . . . . . 65  
 fork . . . . . 69  
 shock absorber . . . . . 70

**Throttle grip** . . . . . 10

**Tire air pressure**  
 checking . . . . . 49

**Tire condition**  
 checking . . . . . 48

**Transport** . . . . . 5

**Troubleshooting** . . . . . 60-61

**U**

**Use definition** . . . . . 5

**V**

**Vehicle level** . . . . . 24

**View of vehicle**  
 left front . . . . . 7  
 right rear . . . . . 8

**W**

**Warranty** . . . . . 5

**Work rules** . . . . . 5





3211478en



04/2009 Photo: Mitterbauer



KTM-Sportmotorcycle AG  
5230 Mattighofen/Austria  
<http://www.ktm.com>